

**EXHIBIT 4 RF EXPOSURE REPORT**

## RF exposure compliance assessment

Multiband 5G Airscale mmWave Radio Solution – AWEWA/B+FA3UB, AWEUC/D+FA3WA

AWEWA/B:

US - FCC ID: 2AD8UAWEWAB01;

FA3UB:

US - FCC ID: 2AD8UASMR24FA3UB, 2AD8UAFA3UB01;

AWEUC/D:

US - FCC ID: 2AD8UASMR24FA3UB;

FA3WA:

US - FCC ID: 2AD8UASMR24FA3UB, 2AD8UAFA3WA01;

Author Kamil Bechta  
 Owner Christophe Grangeat  
 Organization MN RAN Arch  
 Approver Steve Majkowski  
 Document Type Final test report

Document ID xxx

Document location <https://nokia.sharepoint.com/:f/r/sites/EMFProductManagement/Shared%20Documents/General/Products-RF-exposure-assessment/AWEWA?csf=1&web=1&e=yegEee>

Change History									
Version	Status	Date	Author	Owner	Reviewed by	Reviewed date	Approver	Approval date	Description of changes
1.0	Final	15-09-2022	K. Bechta	C. Grangeat	C. Grangeat; Q Yu	15-09-2022	S. Majkowski	xx-09-2022	

This material, including documentation and any related computer programs, is protected by copyright controlled by Nokia. All rights are reserved. Copying, including reproducing, storing, adapting or translating, any or all of this material requires the prior written consent of Nokia. This material also contains confidential information, which may not be disclosed to others without the prior written consent of Nokia.

## Contents

1	General content.....	5
2	References.....	5
2.1	Applicable RF exposure standards and regulations .....	5
2.2	Product and assessment method.....	6
3	RF exposure limits .....	7
4	Description of the equipment under test (EUT) .....	8
5	RF exposure assessment method.....	15
6	RF exposure computation results.....	16
6.1	Regions of application: EU/ICNIRP, Australia/NZ, Canada and US/related .....	16
7	Conclusion and installation recommendations.....	20

## List of Tables

Table 1 – Applicable RF exposure levels in n258 and n260 bands expressed in power density.....	7
Table 2 – AWEWA/B and FA3UB product general technical characteristics.....	8
<b>Table 3 – AWEUC/D and FA3WA product general technical characteristics.....</b>	<b>9</b>
Table 4 - Reference system used in this report (from NGMN white paper [15]).....	10
Table 5 – AWEWA/B and FA3WA antenna pattern models for RF exposure assessment .....	11
Table 6 – AWEUC/D and FA3UB Antenna pattern models for RF exposure assessment .....	12
Table 7 – AWEWA/B and FA3WA antenna gain characteristics for various beam steering directions used during EMF evaluation .....	13
Table 8 – AWEUC/D and FA3UB antenna gain characteristics for various beam steering directions used during EMF evaluation .....	13
Table 9 – Validation of the AWEWA/B and FA3WA antenna model at 38500 MHz .....	15
Table 10 - Validation of the AWEUC/D and FA3UB antenna model at 25750 MHz.....	15
Table 11 – RF exposure compliance distances for Configuration 1 and Configuration 2 based on the time-averaged maximum EIRP of 55.52 dBm per antenna module .....	21
Table 12 – RF exposure compliance distances for Configuration 1 and Configuration 2 based on the actual EIRP threshold of 49.52 dBm per antenna module .....	21

## List of Figures

Figure 1 – Shape of the compliance boundary used for the RF exposure compliance assessment (from [12]). ..... 14

Figure 2 – Co-location configurations of AWEWA/B + FA3UB or AWEUC/D + FA3WA used for the RF exposure assessment to provide conservative compliance distances ..... 14

Figure 3 – Power density from AWEWA/B (or FA3WA) for the time-averaged maximum transmitted power of 1.42 W (corresponding to the time-averaged maximum EIRP of 55.52 dBm) and the beam oriented in azimuth = 0° & elevation = 0°, together with the power density from FA3UB (or AWEUC/D) for the time-averaged maximum transmitted power of 0.76 W (corresponding to the time-averaged maximum EIRP of 55.52 dBm) and the beam oriented in azimuth = 0° & elevation = 0° ..... 16

Figure 4 – Power density from AWEWA/B (or FA3WA) for the actual maximum transmitted power of 0.36 W (corresponding to the actual EIRP threshold of 49.52 dBm) and the beam oriented in azimuth = 0° & elevation = 0°, together with the power density from FA3UB (or AWEUC/D) for the actual maximum transmitted power of 0.19 W (corresponding to the actual EIRP threshold of 49.52 dBm) and the beam oriented in azimuth = 0° & elevation = 0° ..... 17

Figure 5 – Power density from AWEWA/B (or FA3WA) for the time-averaged maximum transmitted power of 1.42 W (corresponding to the time-averaged maximum EIRP of 55.52 dBm) and the beam oriented in azimuth = +60° & elevation = 0°, together with the power density from FA3UB (or AWEUC/D) for the time-averaged maximum transmitted power of 0.76 W (corresponding to the time-averaged maximum EIRP of 55.52 dBm) and the beam oriented in azimuth = +45° & elevation = 0° ..... 17

Figure 6 – Power density from AWEWA/B (or FA3WA) for the actual maximum transmitted power of 1.2 W (corresponding to the actual EIRP threshold of 49.52 dBm) and the beam oriented in azimuth = +60° & elevation = 0°, together with the power density from FA3UB (or AWEUC/D) for the actual maximum transmitted power of 0.37 W (corresponding to the actual EIRP threshold of 49.52 dBm) and the beam oriented in azimuth = +45° & elevation = 0° ..... 18

Figure 7 – Power density from AWEWA/B (or FA3WA) for the time-averaged maximum transmitted power of 1.42 W (corresponding to the time-averaged maximum EIRP of 55.52 dBm) and the beam oriented in azimuth = 0° & elevation = +20°, together with the power density from FA3UB (or AWEUC/D) for the time-averaged maximum transmitted power of 0.76 W (corresponding to the time-averaged maximum EIRP of 55.52 dBm) and the beam oriented in azimuth = 0° & elevation = +15° ..... 18

Figure 8 – Power density from AWEWA/B (or FA3WA) for the actual maximum transmitted power of 0.4 W (corresponding to the actual EIRP threshold of 49.52 dBm) and the beam oriented in azimuth = 0° & elevation = +20°, together with the power density from FA3UB (or AWEUC/D) for the actual maximum transmitted power of 0.2 W (corresponding to the actual EIRP threshold of 49.52 dBm) and the beam oriented in azimuth = 0° & elevation = +15° ..... 19

Figure 9 – Power density from AWEWA/B (or FA3WA) for the time-averaged maximum transmitted power of 1.42 W (corresponding to the time-averaged maximum EIRP of 55.52 dBm) and the beam oriented in azimuth = 0° & elevation = -20°, together with the power density from FA3UB (or AWEUC/D) for the time-averaged maximum transmitted power of 0.76 W (corresponding to the time-averaged maximum EIRP of 55.52 dBm) and the beam oriented in azimuth = 0° & elevation = -15° ..... 19

Figure 10 – Power density from AWEWA/B (or FA3WA) for the actual maximum transmitted power of 0.4 W (corresponding to the actual EIRP threshold of 49.52 dBm) and the beam oriented in azimuth = 0° & elevation = -20°, together with the power density from FA3UB (or AWEUC/D) for the actual maximum transmitted power of 0.2 W (corresponding to the actual EIRP threshold of 49.52 dBm) and the beam oriented in azimuth = 0° & elevation = -15° ..... 20

## 1 General content

This RF exposure assessment report is addressing human exposure to radiofrequency electromagnetic fields (RF-EMF) transmitted by the following Multiband mmWave Radio Solution Product (see §2.2):

- Nokia AWEWA/B Airscale mmWave Radio 5G n260 39GHz
- Nokia FA3UB Extension Module, 5G n258 24GHz
- Nokia AWEUC/D Airscale mmWave Radio 5G n258 24GHz
- Nokia FA3WA Extension Module 5G n260 39GHz

It provides the RF exposure compliance boundaries for these products regarding both general population and occupational exposure. Outside of these compliance boundaries, human exposure to RF-EMF is below the limits established by the US Federal Communications Commission (FCC), Canada Safety Code 6, Australia ARPANSA and European regulations (see §2.1 and [15]).

**NOTE:** The same Tx power, beam patterns and RF exposure limits apply to AWEUC/D (main, 24 GHz) + FA3WA (extension, 39 GHz) and AWEWA/B (main, 39 GHz) + FA3UB (extension, 24 GHz) combinations, therefore the compliance boundaries in this report apply to both combinations.

## 2 References

### 2.1 Applicable RF exposure standards and regulations

- [1] EU 1999/519/EC, “Council Recommendation on the limitation of exposure of the general public to electromagnetic fields (0 Hz to 300 GHz)”, July 1999
- [2] EU 2013/35/EU, “Directive of the European Parliament and of the Council on the minimum health and safety requirements regarding the exposure of workers to the risks arising from physical agents (electromagnetic fields) (20th individual Directive within the meaning of Article 16(1) of Directive 89/391/EEC) and repealing Directive 2004/40/EC”, June 2013
- [3] EN 50385:2017, “Product standard to demonstrate the compliance of base station equipment with radiofrequency electromagnetic field exposure limits (110 MHz - 100 GHz), when placed on the market”, July 2017
- [4] ARPANSA “Standard for Limiting Exposure to Radiofrequency Fields – 100 kHz to 300 GHz”, Radiation Protection Series S-1, Feb 2021
- [5] Canada Safety Code 6, “Limits of Human Exposure to Radiofrequency Electromagnetic Energy in the Frequency Range from 3 kHz to 300 GHz”, June 2015

[6] Canada RSS-102, “Radio Frequency (RF) Exposure Compliance of Radiocommunication Apparatus (All Frequency Bands)”, Issue 5, March 2015, Amendment 1 (February 2, 2021)

[7] US FCC 47CFR 0.71310 “Radiofrequency radiation exposure limits”, August 1997.

## 2.2 Product and assessment method

[8] Microwave Vision Group (MVG), “EMF Visual User Manual”, SEWB/EMF-VISUAL-UM.1/v2021.4.

[9] Z. Altman, B. Begasse, C. Dale, A. Karwowski, J. Wiart, M. Wong and L. Gattoufi, “Efficient models for base station antennas for human exposure assessment”, IEEE Trans. Electromagnetic Compatibility, Nov 2002, vol.44, pp. 588-592.

[10] P. Baracca, A. Weber, T. Wild and C. Grangeat, “A Statistical Approach for RF Exposure Compliance Boundary Assessment in Massive MIMO Systems”, WSA 2018, <https://arxiv.org/abs/1801.08351>.

[11] IEC TR62669, “Case studies supporting the implementation of IEC 62232”, (106/463/CD, July 2018).

[12] IEC 62232 ED3 FDIS (106/576/FDIS), “Determination of RF field strength, power density and SAR in the vicinity of radiocommunication base stations for the purpose of evaluating human exposure”, 2022.

[13] AS/NZS 2772.2, "Radiofrequency fields Part 2: Principles and methods of measurement and computation-3 kHz to 300 GHz", 2016, AMD 1:2018

[14] US FCC OET Bulletin 65, “Evaluating Compliance with FCC Guidelines for Human Exposure to Radiofrequency Electromagnetic Fields and its supplements”, edition 97-01, August 1997.

[15] NGMN white paper, “Recommendation on Base Station Active Antenna System Standards v1.0”, July 2020, [https://www.ngmn.org/wp-content/uploads/Publications/2020/NGMN\\_BASTA-AA\\_WP\\_1\\_0.pdf](https://www.ngmn.org/wp-content/uploads/Publications/2020/NGMN_BASTA-AA_WP_1_0.pdf)

## 3 RF exposure limits

The applicable RF exposure limits are established by [1], [2] and [3] in Europe and ICNIRP countries, by [4] in Australia and New Zealand, by [5] and [6] in Canada and by [7] in the US and related countries such as Bolivia, Estonia, Mexico and Panama. The applicable power density limits are recalled in Table 1 for the frequency range applicable to the equipment under test.

Table 1 – Applicable RF exposure levels in n258 and n260 bands expressed in power density



Region of application	General Population/Uncontrolled Exposures	Occupational/Controlled Exposures
EU/ICNIRP, Australia/NZ, US/related, Canada	10 W/m <sup>2</sup>	50 W/m <sup>2</sup>



## 4 Description of the equipment under test (EUT)

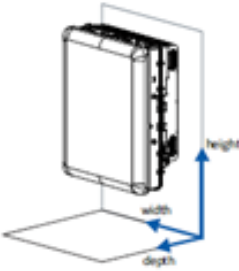
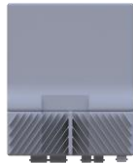

The main technical characteristics of AWEWA/B and FA3UB product are reproduced in Table 2.

Table 2 – AWEWA/B and FA3UB product general technical characteristics

Product name	Nokia AWEWA/B Airscale mmWave Radio 5G n260 39GHz Nokia FA3UB Extension Module, 5G n258 24GHz	
Model number	AWEWA – 475170A (AC) AWEWB – 475171A (DC) FA3UB – 475046A	
Number of TXRX per antenna module	2TX2RX	
Beamforming	Yes	
SW supported techno.	5G NR TDD	
Frequency range	AWEWA/B: 37000 – 40000 MHz (3GPP n260) FA3UB: 24250–27500MHz (3GPP n258)	
Nb of antenna elements per antenna module	12 (row) x 8 (column) x 2 (polarization)	
	AWEWA/B	FA3UB
Rated max Tx power per antenna module	1.26 W	0.8 W
Gain per antenna assembly	24 dBi	26.7 dBi
EIRP per antenna assembly	52 dBm	52 dBm
EIRP per antenna module	55 dBm	55 dBm
Azimuth scanning range per antenna module	±60°	±45°
Elevation scanning range per antenna module	±20°	±15°
Dimensions 	AWEWA/B: Height: 325 mm Width: 270 mm Depth: 115 mm	
	FA3UB: Height: 201 mm Width: 270 mm Depth: 90 mm	
Technology duty cycle factor	80 %	
Transmitted power tolerance	1.5 dB	

The main technical characteristics of AWEUC/D and FA3WA product are reproduced in Table 3.

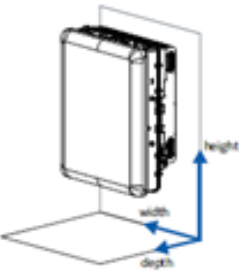
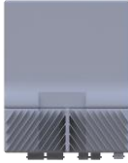
**Table 3 – AWEUC/D and FA3WA product general technical characteristics**

Product name	Nokia AWEUC/D Airscale mmWave Radio 5G n258 24GHz Nokia FA3WA Extension Module 5G n260 39GHz	
Model number	AWEUC – 475168A (AC) AWEUD – 475169A (DC) FA3WA – 475002A	
Number of TXRX per antenna module	2TX2RX	
Beamforming	Yes	
SW supported techno.	5G NR TDD	
Frequency range	AWEUC/D: 24250–27500MHz (3GPP n258) FA3WA: 37000 – 40000 MHz (3GPP n260)	
Nb of antenna elements per antenna module	12 (row) x 8 (column) x 2 (polarization)	
	AWEUC/D	FA3WA
Rated max Tx power per antenna module	0.8 W	1.26 W
Gain per antenna assembly	26.7 dBi	24 dBi
EIRP per antenna assembly	52 dBm	52 dBm
EIRP per antenna module	55 dBm	55 dBm
Azimuth scanning range per antenna module	±45°	±60°
Elevation scanning range per antenna module	±15°	±20°
Dimensions 	AWEUC/D: Height: 325 mm Width: 270 mm Depth: 155 mm	
	FA3WA: Height: 211 mm Width: 270 mm Depth: 80 mm	
Technology duty cycle factor	80 %	
Transmitted power tolerance	1.5 dB	

The antenna model used for the RF exposure assessment is derived from the model of the antenna array (pattern and gain) using the real beamforming weights (BFW) configured in the product. The antenna model is validated with the product antenna model using the same BFW,

pattern and gain. Table 5 - Table 8 include the EMF Visual models for beam configurations used for the assessment of the compliance boundary. Selected patterns ensure that maximum compliance distance, applicable to evaluated product, is obtained.

Azimuth and elevation angles indicated in this report are provided according to the reference system used in product data sheets (see Table 4), unless otherwise stated.

Table 4 - Reference system used in this report (from NGMN white paper [15])

<p>3D view Defintion of azimuth <math>\varphi</math> and elevation <math>\theta</math></p>	
<p>Top view (horizontal cut) Definition of azimuth <math>\varphi</math></p>	
<p>Side view (vertical cut) Definition of elevation <math>\theta</math></p>	

Table 5 – AWEWA/B and FA3WA antenna pattern models for RF exposure assessment

	Horizontal cut	Vertical cut
Boresight		
Max azimuth		
Max up-tilt		
Max down-tilt		
<p>NOTE: Angle references used in these graphs are derived from EMF Visual, which may differ from product data sheet (see Table 4)</p>		

Table 6 – AWEUC/D and FA3UB Antenna pattern models for RF exposure assessment

	Horizontal cut	Vertical cut
Boresight		
Max azimuth		
Max up-tilt		
Max down-tilt		
<p>NOTE: Angle references used in these graphs are derived from EMF Visual, which may differ from product data sheet (see Table 4)</p>		

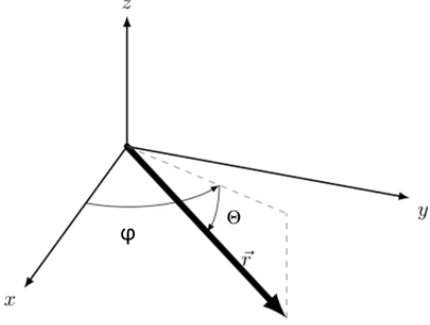
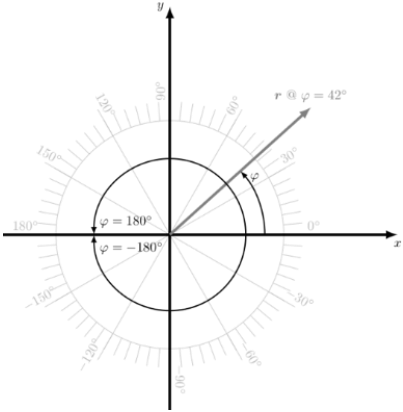
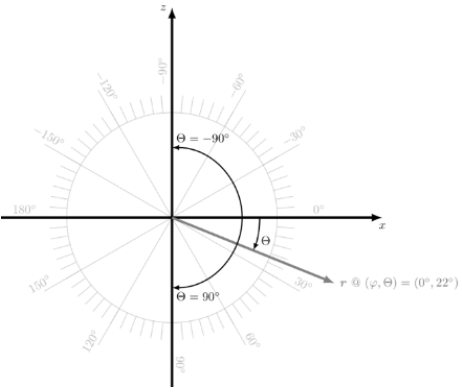
Table 7 – AWEWA/B and FA3WA antenna gain characteristics for various beam steering directions used during EMF evaluation

	Azimuth	Elevation	Gain (dBi)
			38500 MHz
Boresight	0°	0°	24.0
Max azimuth	+60°	0°	18.7
Max up-tilt	0°	-20°	23.5
Max down-tilt	0°	+20°	23.5

Table 8 – AWEUC/D and FA3UB antenna gain characteristics for various beam steering directions used during EMF evaluation

	Azimuth	Elevation	Gain (dBi)
			25750 MHz
Boresight	0°	0°	26.7
Max azimuth	+45°	0°	23.8
Max up-tilt	0°	-15°	26.4
Max down-tilt	0°	+15°	26.4

The compliance boundary is described by the box shape perimeter shown in Figure 4 of IEC 62232 [12] and displayed in Figure 1. The distances  $D_f$ ,  $D_{s,a}$ ,  $D_{u,a}$  and  $D_{d,a}$  are taken from the nearest point of the antenna. For convenience, the distances  $D_{s,c}$ ,  $D_{u,c}$  and  $D_{d,c}$  (respectively) taken from antenna center are also provided.

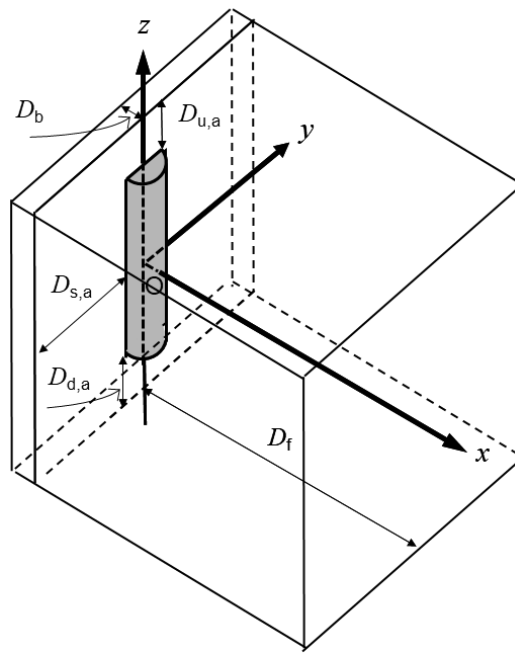

Figure 1 – Shape of the compliance boundary used for the RF exposure compliance assessment (from [12]).

Two co-location configurations of AWEWA/B + FA3UB and AWEUC/D + FA3WA have been assessed as presented on Figure 2 in order to provide conservative distances in front, on the sides and up/down. Configuration 1 (stacked) provide relevant compliance distances in front as well as up and down, when measured to the edge of the nearest antenna. Configuration 2 (side-by-side) relevant compliance distances in front as well as to the sides, when measured to the edge of the nearest antenna. Final compliance distances  $D_f$ ,  $D_{s,a}$ ,  $D_{u,a}$  and  $D_{d,a}$  correspond to the highest value obtained from both configurations.

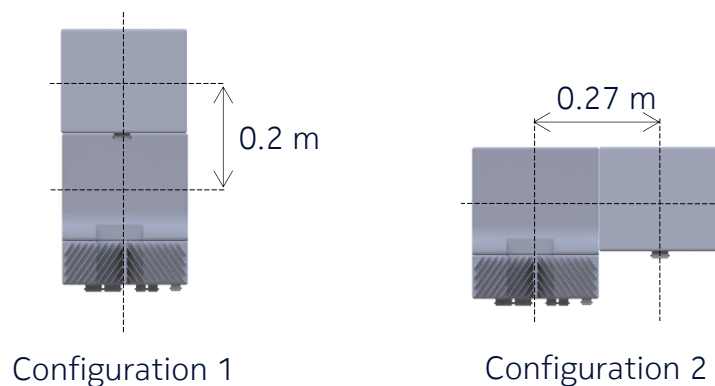

Figure 2 – Co-location configurations of AWEWA/B + FA3UB or AWEUC/D + FA3WA used for the RF exposure assessment to provide conservative compliance distances

## 5 RF exposure assessment method

RF exposure assessment is performed using the synthetic model computation method specified in B.7.2.1 of IEC 62232 [12]. Calculations are performed with the “EMF Visual” software release OKTAL 2021.4 Version 4.0 (see [8] and [9]).

The validation of the model is performed in the configuration with the beam in front (azimuth = 0° and elevation = 0°). The validation results are provided in Table 9 and Table 10.

Table 9 – Validation of the AWEWA/B and FA3WA antenna model at 38500 MHz

	Product model	EMF Visual model	Deviation
Gain	24.0 dBi	24.0 dBi	0.0 dB
Horizontal half-power beamwidth	13.1°	13.5°	0.4°
Vertical half-power beamwidth	6.8°	7.0°	0.2°

Table 10 - Validation of the AWEUC/D and FA3UB antenna model at 25750 MHz

	Product model	EMF Visual model	Deviation
Gain	26.7 dBi	26.7 dBi	0.0 dB
Horizontal half-power beamwidth	13.4°	13.5°	0.1°
Vertical half-power beamwidth	6.5°	7.0°	0.5°

For each configuration, the directivity pattern is derived from the simulation model and the antenna gain is adjusted to match exactly the simulated values for accurate scaling.

The compliance distances are assessed for the following transmitted power configurations:

- In case of AWEWA/B or FA3WA, for the time-averaged maximum transmitted power of 1.42 W, corresponding to the time-averaged maximum EIRP of 55.52 dBm for the beam with gain of 24.0 dBi in the boresight direction. The RF compliance distances are also provided for the actual EIRP threshold of 49.52 dBm, applying a power reduction factor of – 6 dB as specified in [10], [11] and [12].
- In case of AWEUC/D or FA3UB, for the time-averaged maximum transmitted power of 0.76 W, corresponding to the time-averaged maximum EIRP of 55.52 dBm for the beam with gain of 26.7 dBi in the boresight direction. The RF compliance distances are also



provided for the actual EIRP threshold of 49.52 dBm, applying a power reduction factor of - 6 dB as specified in [10], [11] and [12].

Above values of transmitted power include a technology duty cycle factor of 80 % (see Table 2 and Table 3) for time averaging and a power tolerance of 1.5 dB due to electronic component dispersion and operational environmental conditions (temperature).

## 6 RF exposure computation results

### 6.1 Regions of application: EU/ICNIRP, Australia/NZ, Canada and US/related

The computed power density 3D distributions are displayed in Figure 3 to Figure 10 for RF exposure limits established in [1], [2] and [3] for EU/ICNIRP countries, [4] for Australia/NZ, [5] and [6] for Canada and [7] for US/related countries. Presented are results of power density from beams of AWEWA/B and FA3UB, or AWEUC/D and FA3WA, oriented towards the same direction.

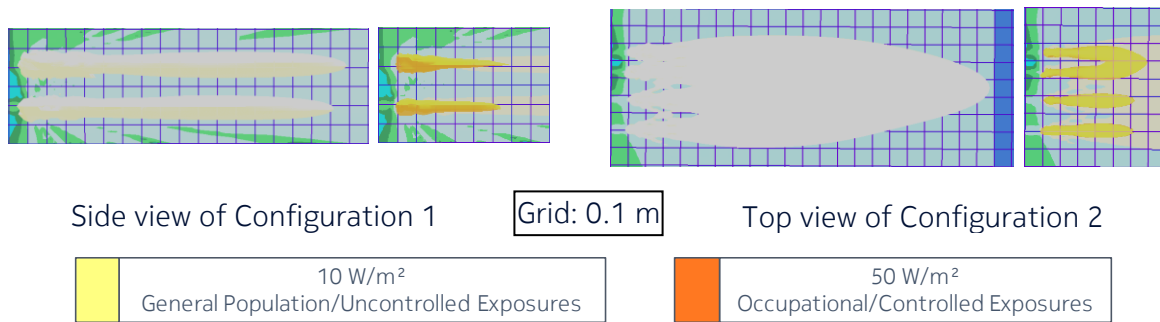

Figure 3 – Power density from AWEWA/B (or FA3WA) for the time-averaged maximum transmitted power of 1.42 W (corresponding to the time-averaged maximum EIRP of 55.52 dBm) and the beam oriented in azimuth = 0° & elevation = 0°, together with the power density from FA3UB (or AWEUC/D) for the time-averaged maximum transmitted power of 0.76 W (corresponding to the time-averaged maximum EIRP of 55.52 dBm) and the beam oriented in azimuth = 0° & elevation = 0°

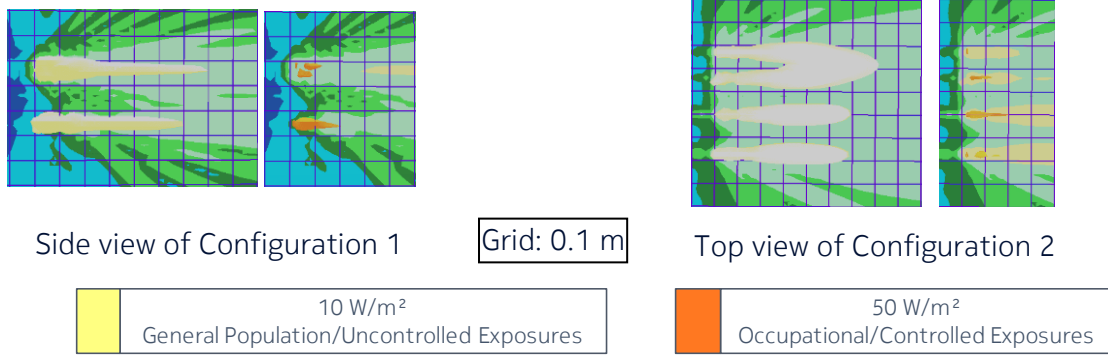

Figure 4 – Power density from AWEWA/B (or FA3WA) for the actual maximum transmitted power of 0.36 W (corresponding to the actual EIRP threshold of 49.52 dBm) and the beam oriented in azimuth = 0° & elevation = 0°, together with the power density from FA3UB (or AWEUC/D) for the actual maximum transmitted power of 0.19 W (corresponding to the actual EIRP threshold of 49.52 dBm) and the beam oriented in azimuth = 0° & elevation = 0°

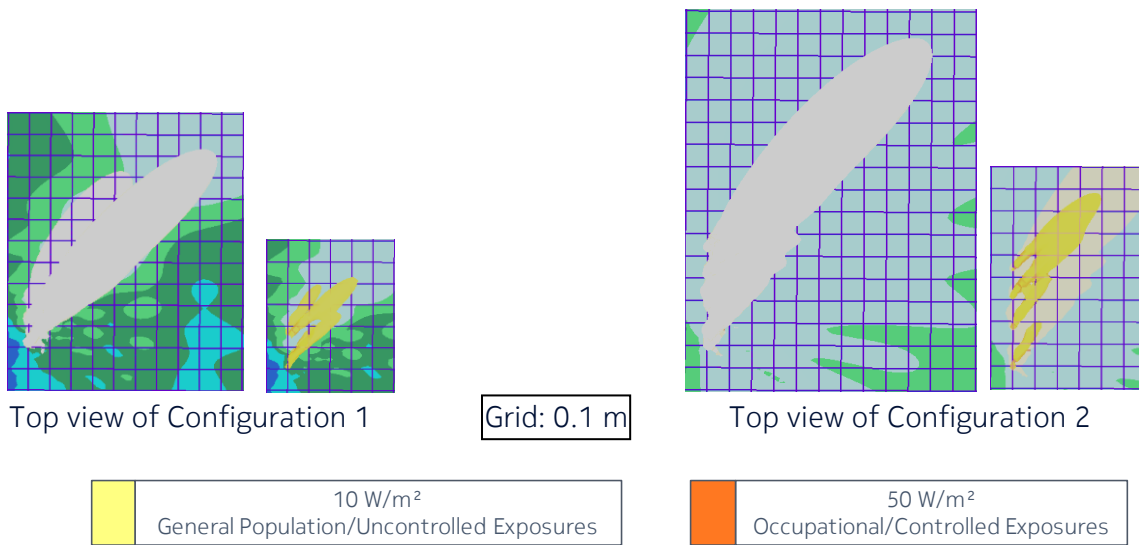

Figure 5 – Power density from AWEWA/B (or FA3WA) for the time-averaged maximum transmitted power of 1.42 W (corresponding to the time-averaged maximum EIRP of 55.52 dBm) and the beam oriented in azimuth = +60° & elevation = 0°, together with the power density from FA3UB (or AWEUC/D) for the time-averaged maximum transmitted power of 0.76 W (corresponding to the time-averaged maximum EIRP of 55.52 dBm) and the beam oriented in azimuth = +45° & elevation = 0°

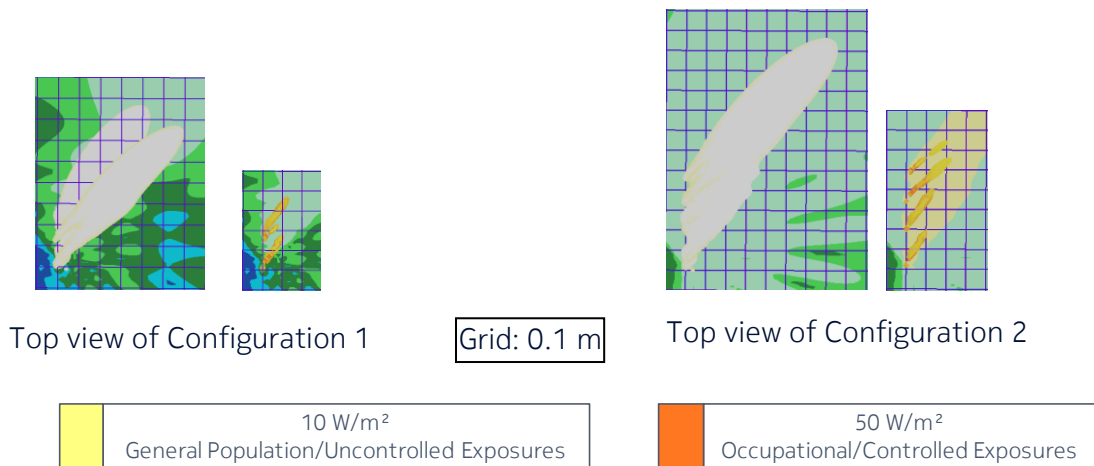

Figure 6 – Power density from AWEWA/B (or FA3WA) for the actual maximum transmitted power of 1.2 W (corresponding to the actual EIRP threshold of 49.52 dBm) and the beam oriented in azimuth = +60° & elevation = 0°, together with the power density from FA3UB (or AWEUC/D) for the actual maximum transmitted power of 0.37 W (corresponding to the actual EIRP threshold of 49.52 dBm) and the beam oriented in azimuth = +45° & elevation = 0°

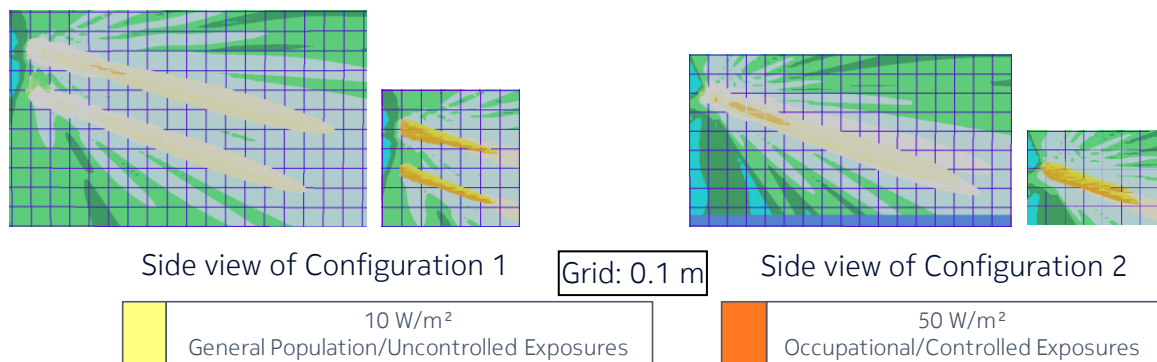

Figure 7 – Power density from AWEWA/B (or FA3WA) for the time-averaged maximum transmitted power of 1.42 W (corresponding to the time-averaged maximum EIRP of 55.52 dBm) and the beam oriented in azimuth = 0° & elevation = +20°, together with the power density from FA3UB (or AWEUC/D) for the time-averaged maximum transmitted power of 0.76 W (corresponding to the time-averaged maximum EIRP of 55.52 dBm) and the beam oriented in azimuth = 0° & elevation = +15°

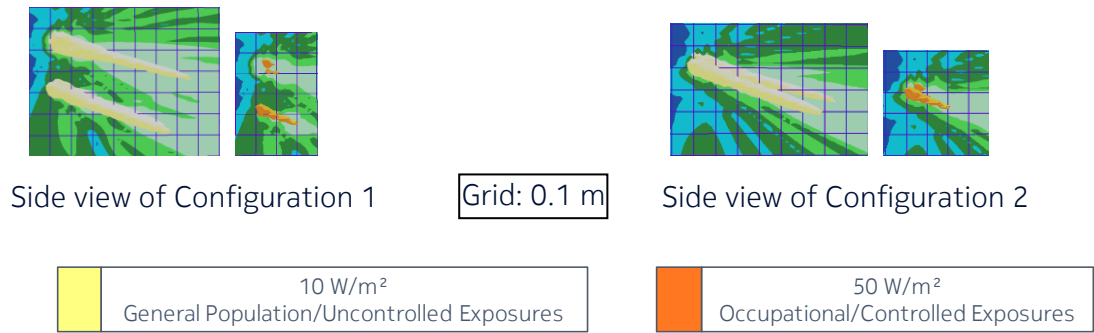

Figure 8 – Power density from AWEWA/B (or FA3WA) for the actual maximum transmitted power of 0.4 W (corresponding to the actual EIRP threshold of 49.52 dBm) and the beam oriented in azimuth = 0° & elevation = +20°, together with the power density from FA3UB (or AWEUC/D) for the actual maximum transmitted power of 0.2 W (corresponding to the actual EIRP threshold of 49.52 dBm) and the beam oriented in azimuth = 0° & elevation = +15°

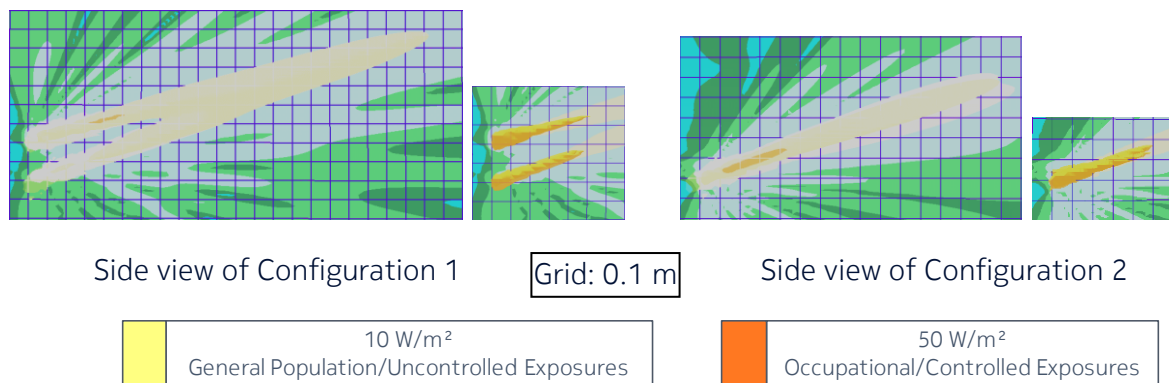

Figure 9 – Power density from AWEWA/B (or FA3WA) for the time-averaged maximum transmitted power of 1.42 W (corresponding to the time-averaged maximum EIRP of 55.52 dBm) and the beam oriented in azimuth = 0° & elevation = -20°, together with the power density from FA3UB (or AWEUC/D) for the time-averaged maximum transmitted power of 0.76 W (corresponding to the time-averaged maximum EIRP of 55.52 dBm) and the beam oriented in azimuth = 0° & elevation = -15°

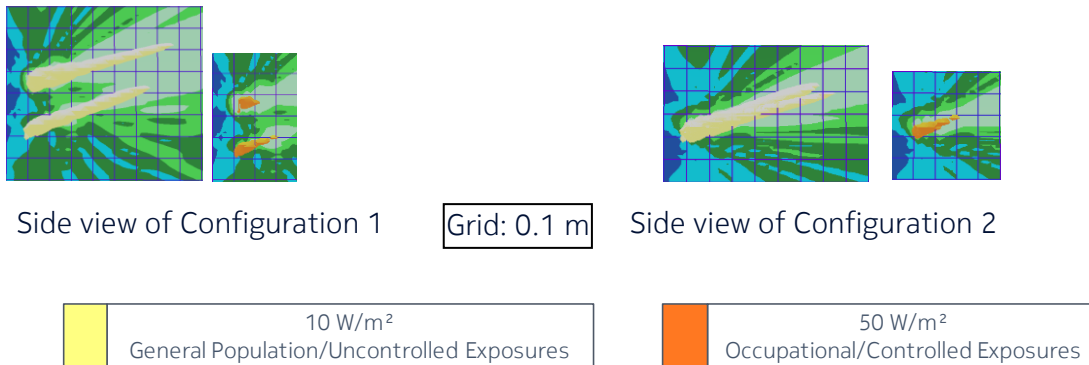

Figure 10 – Power density from AWEWA/B (or FA3WA) for the actual maximum transmitted power of 0.4 W (corresponding to the actual EIRP threshold of 49.52 dBm) and the beam oriented in azimuth = 0° & elevation = -20°, together with the power density from FA3UB (or AWEUC/D) for the actual maximum transmitted power of 0.2 W (corresponding to the actual EIRP threshold of 49.52 dBm) and the beam oriented in azimuth = 0° & elevation = -15°

## 7 Conclusion and installation recommendations

The RF exposure compliance distances applicable for the co-located installation of the Nokia AWEWA/B Airscale mmWave Radio 5G n260 39GHz and the Nokia FA3UB Extension Module 5G n258 24GHz products, or Nokia AWEUC/D Airscale mmWave Radio 5G n258 24GHz and Nokia FA3WA Extension Module 5G n260 39GHz, whether in a stacked position or side-by-side, are summarized in Table 11 for EU/ICNIRP [1][2][3], Australia/NZ [4], for Canada [5][6] and US/related [7] requirements. Compliance distances in Table 11 and Table 12 are measured from the nearest radio unit. They apply to any co-location installation, whether one radio unit is placed above and below in case of a stacked position or right and left in case of side-by-side.

Table 11 – RF exposure compliance distances for Configuration 1 and Configuration 2 based on the time-averaged maximum EIRP of 55.52 dBm per antenna module

Region of application: EU/ICNIRP, Australia/NZ, Canada and US/related	General Population/Uncontrolled Exposures	Occupational/ Controlled Exposures
RF-EMF power density exposure limits	10 W/m <sup>2</sup>	50 W/m <sup>2</sup>
Distance in front ( $D_f$ )	2.1 m	0.6 m
Distance to the side ( $D_{s,a}$ )	0.9 m	0.3 m
Distance below and above ( $D_{d,a}$ ) ( $D_{u,a}$ )	0.5 m	0.1 m
Distance to the side from the center ( $D_{s,c}$ )	1.0 m	0.4 m
Distance below and above from the center ( $D_{d,c}$ ) ( $D_{u,c}$ )	0.6 m	0.2 m

The RF exposure compliance distances based on the actual maximum transmitted power considering a 95<sup>th</sup> percentile approach are summarized in Table 12. These values are provided for information about the RF exposure levels that may be reached in operational conditions considering a time-averaging window of 6 minutes according to [10], [11] and [12].

Table 12 – RF exposure compliance distances for Configuration 1 and Configuration 2 based on the actual EIRP threshold of 49.52 dBm per antenna module

For information in EU/ICNIRP, Australia/NZ and US/related countries based on IEC/EN 62232 [12] and IEC TR62669 [11]	General Population/Uncontrolled Exposures	Occupational/ Controlled Exposures
RF-EMF power density exposure limits	10 W/m <sup>2</sup>	50 W/m <sup>2</sup>
Distance in front ( $D_f$ )	0.8 m	0.2 m
Distance to the side ( $D_{s,a}$ )	0.7 m	0.2 m
Distance below and above ( $D_{d,a}$ ) ( $D_{u,a}$ )	0.2 m	0.0 m
Distance to the side from the center ( $D_{s,c}$ )	0.8 m	0.3 m
Distance below and above from the center ( $D_{d,c}$ ) ( $D_{u,c}$ )	0.3 m	0.1 m

Installation of the Nokia AWEWA/B Airscale mmWave Radio 5G n260 39GHz and the Nokia FA3UB Extension Module 5G n258 24GHz products, or Nokia AWEUC/D Airscale mmWave Radio 5G n258 24GHz and Nokia FA3WA Extension Module 5G n260 39GHz, whether in a stacked position or side-by-side, shall be performed in accordance with all applicable manufacturer's recommendations and national laws and regulations related to human exposure to radiofrequency fields. In particular:

- The operator or entity putting the equipment into service shall take the necessary measures to ensure that the general population cannot access the area within the general population/uncontrolled compliance boundary in the vicinity of the transmitting antennas (see Table 11).
- Depending on the site installation configuration, the operator or the entity putting the equipment into service determines the most suitable place to display the appropriate warning signs and any other necessary information or precautionary measures.
- Workers that are required to operate in the close proximity of the transmitting antennas connected to the equipment, for example installation and maintenance personnel, need to be informed about the potential risks of human exposure to RF fields and how to protect against them. They should strictly follow instructions provided by their employer. They should stand-off the occupational/controlled exposure compliance boundary assessed in the vicinity of transmitting antennas (see Table 11). If it is necessary to operate within this compliance boundary, workers shall make sure that the transmitters contributing to exposure in this area are all switched off, or they must contact the relevant operator(s) to switch off emissions during operation period.

----- end of the test report -----