

MEASUREMENT REPORT

FCC PART 24 & 27

FCC ID: 2AD8UAHFIH01

Application: Nokia Solutions and Networks, OY

Application Type: Class II Permissive Change

Product: AirScale Indoor Radio ASiR-pRRH

Model No.: AHFIH

Brand Name: Nokia

FCC Rule Part(s): Part 24 Subpart E, 27 Subpart L

Test Procedure(s): ANSI C63.26-2015

Test Date: October 23, 2020 ~ April 06, 2021

Reviewed By: *Paddy Chen*
(Paddy Chen)

Approved By: *Chenz Ker*
(Chenz Ker)



The test results relate only to the samples tested.

This equipment has been shown to be capable of compliance with the applicable technical standards as indicated in the measurement report and was tested in accordance with the measurement procedures specified in ANSI C63.26-2015. Test results reported herein relate only to the item(s) tested.

The test report shall not be reproduced except in full without the written approval of MRT Technology (Taiwan) Co., Ltd.

Revision History

Report No.	Version	Description	Issue Date	Note
2006TW0003-U4	Rev. 01	Initial Report	04-21-2021	Valid

Note: This report is prepared for FCC Class II permissive supplement to MRT Original report No. 2006TW0003-U2, added 5G NR technology and related data.

CONTENTS

Description	Page
General Information.....	5
1. INTRODUCTION.....	6
1.1. Scope.....	6
1.2. MRT Test Location	6
2. PRODUCT INFORMATION.....	7
2.1. Equipment Description	7
2.2. Emission Designator	7
2.3. Description of Available Antennas	8
2.4. Test Mode Detail	9
2.5. Test Methodology	9
2.6. EMI Suppression Device(s)/Modifications.....	9
2.7. Test Environment Condition.....	9
3. DESCRIPTION of TEST.....	10
3.1. Evaluation Procedure	10
3.2. Radiated Emissions.....	10
4. TEST EQUIPMENT CALIBRATION DATE.....	12
5. MEASUREMENT UNCERTAINTY	13
6. TEST RESULT	14
6.1. Summary.....	14
6.2. Equivalent Isotropically Radiated Power Measurement	15
6.2.1. Test Limit	15
6.2.2. Test Procedures Used	15
6.2.3. Test Setting.....	15
6.2.4. Test Setup	16
6.2.5. Test Result.....	17
6.3. Frequency Stability Measurement	29
6.3.1. Test Limit	29
6.3.2. Test Procedures Used	29
6.3.3. Test Setting.....	29
6.3.4. Test Setup	30
6.3.5. Test Result.....	31
6.4. Emission Bandwidth	33
6.4.1. Test Limit	33

6.4.2.	Test Procedure	33
6.4.3.	Test Setting.....	33
6.4.4.	Test Setup	34
6.4.5.	Test Result.....	35
6.5.	Band Edge Measurement.....	65
6.5.1.	Test Limit	65
6.5.2.	Test Procedure Used	65
6.5.3.	Test Setting.....	65
6.5.4.	Test Setup	66
6.5.5.	Test Result.....	67
6.6.	Peak to Average Ratio.....	81
6.6.1.	Test Limit	81
6.6.2.	Test Procedure Used	81
6.6.3.	Test Setting.....	81
6.6.4.	Test Setup	81
6.6.5.	Test Result.....	82
6.7.	Conducted Spurious Emissions.....	88
6.7.1.	Test Limit	88
6.7.2.	Test Procedure Used	88
6.7.3.	Test Setting.....	88
6.7.4.	Test Setup	89
6.7.5.	Test Result.....	90
6.8.	Radiated Spurious Emissions Measurements	105
6.8.1.	Test Limit	105
6.8.2.	Test Procedure Used	105
6.8.3.	Test Setting.....	105
6.8.4.	Test Setup	106
6.8.5.	Test Result.....	107
7.	CONCLUSION	119

General Information

Applicant:	Nokia Solutions and Networks, OY
Applicant Address:	2000 W. Lucent Lane, Naperville, Illinois, United States, 60563
Manufacturer:	Nokia Solutions and Networks, OY
Manufacturer Address:	2000 W. Lucent Lane, Naperville, Illinois, United States, 60563
Test Site:	MRT Technology (Taiwan) Co., Ltd
Test Site Address:	No. 38, Fuxing Second Rd., Guishan Dist., Taoyuan City 333, Taiwan (R.O.C)

Test Facility / Accreditations

Measurements were performed at MRT Laboratory located in Fuxing Rd., Taoyuan, Taiwan (R.O.C)

- MRT facility is a FCC registered (Reg. No. TW3261) test facility with the site description report on file and is designated by the FCC as an Accredited Test Film.
- MRT facility is an IC registered (MRT Reg. No. 21723-1) test laboratory with the site description on file at Industry Canada.
- MRT Lab is accredited to ISO 17025 by the American Association for Laboratory Accreditation (TAF) under the American Association for Laboratory Accreditation Program (TAF Cert. No. 3261) in EMC, Telecommunications and Radio testing for FCC, Industry Taiwan, EU and TELEC Rules.

1. INTRODUCTION

1.1. Scope

Measurement and determination of electromagnetic emissions (EMC) of radio frequency devices including intentional and/or unintentional radiators for compliance with the technical rules and regulations of the Federal Communications Commission and the Industry Canada Certification and Engineering Bureau.

1.2. MRT Test Location

The map below shows the location of the MRT LABORATORY, its proximity to the Taoyuan City. These measurement tests were conducted at the MRT Technology (Taiwan) Co., Ltd. Facility located at No.38, Fuxing 2nd Rd., Guishan Dist., Taoyuan City 33377, Taiwan (R.O.C).

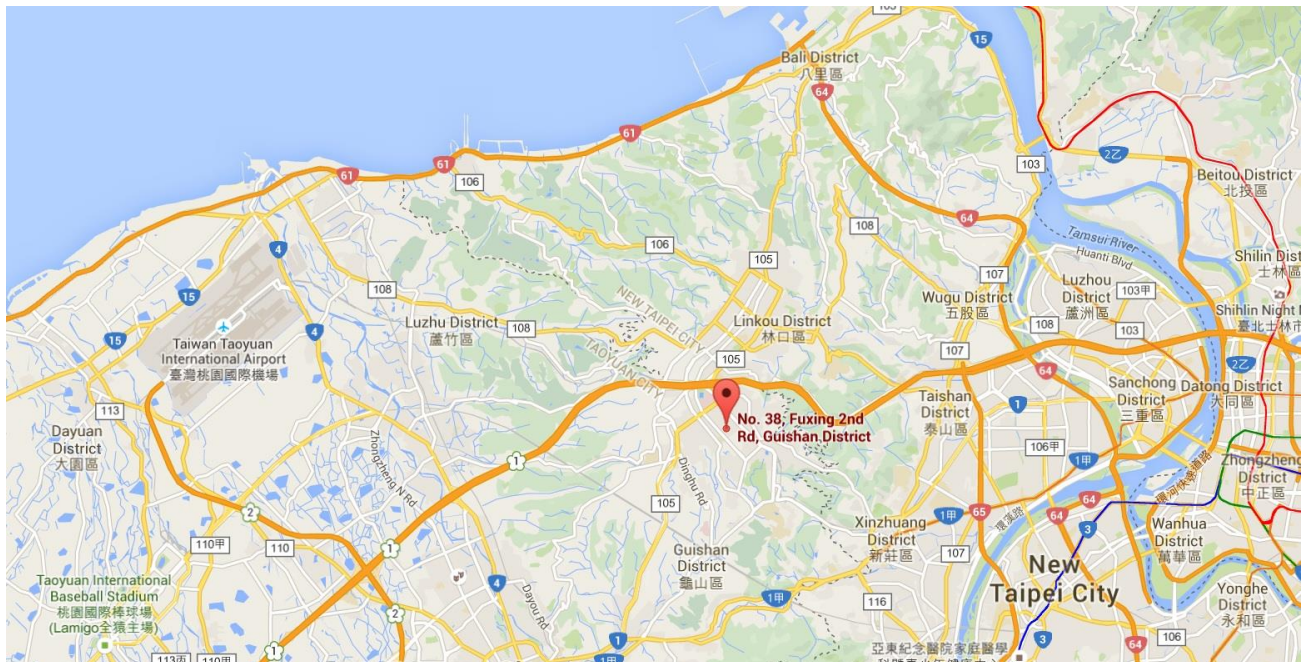

2. PRODUCT INFORMATION

2.1. Equipment Description

Product Name:	AirScale Indoor Radio ASiR-pRRH
Model No.:	AHFIH
Brand Name:	Nokia
Test Device Serial No.:	NH203500565
Hardware Version:	A102
Software Version:	FL18A
Voltage Range:	PoE: 52 ~ 57Vdc
Operating Band (s):	5G NR n25, n66
Modulation Type:	QPSK, 16QAM, 64QAM, 256QAM
T _x Frequency Range:	n25: 1930 ~ 1995 MHz; n66: 2110 ~ 2180 MHz
R _x Frequency Range:	n25: 1850 ~ 1915 MHz; n66: 1710 ~ 1780 MHz
Max EIRP Power:	<u>n25:</u> 5MHz: 31.36dBm; 10MHz: 31.11dBm; 15MHz: 30.91dBm 20MHz: 31.48dBm <u>n66:</u> 5MHz: 32.28dBm; 10MHz: 32.20dBm; 15MHz: 32.28dBm 20MHz: 32.40dBm; 5 + 5MHz: 32.28dBm; 10 + 10MHz: 32.17dBm 15 + 15MHz: 32.43dBm; 20 + 20MHz: 32.02dBm
Emission Designator:	Refer to Section 2.2
Antenna Specification:	Refer to Section 2.3

2.2. Emission Designator

n25		QPSK			16QAM		
BW (MHz)	Feq. (MHz)	Designator	Tolerance (ppm)	Max Power (W)	Designator	Tolerance (ppm)	Max Power (W)
5	1932.5 - 1992.5	4M57G7D	-	1.3687	4M54W7D	-	1.1176
10	1935.0 - 1990.0	9M23G7D	-	1.2909	9M26W7D	-	1.2075
15	1937.5 - 1987.5	14M2G7D	-	1.2089	14M2W7D	-	1.2334
20	1940.0 - 1985.0	19M1G7D	-	1.4044	19M1W7D	-	1.2345
n25		64QAM			256QAM		
BW (MHz)	Feq. (MHz)	Designator	Tolerance (ppm)	Max Power (W)	Designator	Tolerance (ppm)	Max Power (W)
5	1932.5 - 1992.5	4M51W7D	-	1.0822	4M50W7D	-	1.0624
10	1935.0 - 1990.0	9M33W7D	-	0.9998	9M32W7D	-	1.1585
15	1937.5 - 1987.5	14M2W7D	-	1.1706	14M2W7D	-	1.0102
20	1940.0 - 1985.0	19M0W7D	-	1.0752	19M0W7D	-	1.0777

n66		QPSK			16QAM		
BW (MHz)	Feq. (MHz)	Designator	Tolerance (ppm)	Max Power (W)	Designator	Tolerance (ppm)	Max Power (W)
5	2112.5 ~ 2177.5	4M57G7D	-	1.6885	4M56W7D	-	1.5758
10	2115.0 ~ 2175.0	9M20G7D	-	1.6125	9M25W7D	-	1.6577
15	2117.5 ~ 2172.5	14M2G7D	-	1.6349	14M2W7D	-	1.6885
20	2120.0 ~ 2170.0	19M0G7D	-	1.7378	19M0W7D	-	1.5538
5 + 5	2115.0 ~ 2175.0	9M48G7D	-	1.6315	9M47W7D	-	1.6657
10 + 10	2120.0 ~ 2170.0	19M1G7D	-	1.5718	19M1W7D	-	1.6497
15 + 15	2125.0 ~ 2165.0	29M1G7D		1.7494	29M1W7D		1.3832
20 + 20	2130.0 ~ 2160.0	38M9G7D		1.5937	38M9W7D		1.2924
n66		64QAM			256QAM		
BW (MHz)	Feq. (MHz)	Designator	Tolerance (ppm)	Max Power (W)	Designator	Tolerance (ppm)	Max Power (W)
5	2112.5 ~ 2177.5	4M52W7D	-	1.5904	4M50W7D	-	1.3443
10	2115.0 ~ 2175.0	9M33W7D	-	1.5722	9M32W7D	-	1.3228
15	2117.5 ~ 2172.5	14M2W7D	-	1.4914	14M2W7D	-	1.2838
20	2120.0 ~ 2170.0	19M0W7D	-	1.4737	19M0W7D	-	1.3443
5 + 5	2115.0 ~ 2175.0	9M45W7D	-	1.6889	9M43W7D	-	1.3810
10 + 10	2120.0 ~ 2170.0	19M2W7D	-	1.4571	19M2W7D	-	1.4174
15 + 15	2125.0 ~ 2165.0	29M0W7D		1.3960	29M0W7D		1.4057
20 + 20	2130.0 ~ 2160.0	38M7W7D		1.2835	38M7W7D		1.2954

2.3. Description of Available Antennas

Band Support	Antenna Type	Model	Antenna Gain
Band 2	Omni-Directional	CMQ69273P	5.7dBi
Band 66			5.7dBi

2.4. Test Mode Detail

Test Item	Channel Bandwidth	Modulation
Equivalent Isotropically Radiated Power	5 MHz, 10 MHz 15 MHz, 20MHz	QPSK, 16QAM, 64QAM, 256QAM
Emission Bandwidth		QPSK, 16QAM, 64QAM, 256QAM
Band Edge Measurements		QPSK
Conducted Spurious Emissions		QPSK
Radiated Spurious Emissions		QPSK
Peak to Average Ratio		QPSK
Frequency Stability		20MHz
Equivalent Isotropically Radiated Power	5 + 5 MHz, 10 +10 MHz, 15 + 15 MHz, 20 + 20 MHz	QPSK, 16QAM, 64QAM, 256QAM
Emission Bandwidth		QPSK, 16QAM, 64QAM, 256QAM
Band Edge Measurements		QPSK
Conducted Spurious Emissions		QPSK

Note: This report has assessed the typical multi-carrier mode (symmetry mode).

2.5. Test Methodology

According to the specifications of the manufacturer, the EUT must comply with the requirements of the following standards:

- ANSI C63.26:2015
- FCC CFR 47 Part 2, Part 24, Part 27
- FCC KDB 971168 D01 v03r01: Power Meas License Digital Systems
- FCC KDB 412172 D01 v01r01: Determining ERP and EIRP

2.6. EMI Suppression Device(s)/Modifications

No EMI suppression device(s) were added and/or no modifications were made during testing.

2.7. Test Environment Condition

Ambient Temperature	15 ~ 35°C
Relative Humidity	20 ~ 75%RH

3. DESCRIPTION of TEST

3.1. Evaluation Procedure

The measurement procedure described in the document titled “American National Standard for Compliance Testing of Transmitters Used in Licensed Radio Services (ANSI C63.26-2015) was used in the measurement.

Deviation from measurement procedure.....None

3.2. Radiated Emissions

The radiated test facilities consisted of an indoor 3 meter semi-anechoic chamber used for final measurements and exploratory measurements, when necessary. The measurement area is contained within the semi-anechoic chamber which is shielded from any ambient interference. For measurements above 1GHz absorbers are arranged on the floor between the turn table and the antenna mast in such a way so as to maximize the reduction of reflections. For measurements below 1GHz, the absorbers are removed. A turntable is used for radiated measurement. It is a continuously rotatable, remote controlled, metallic turntable and 2 meters (6.56 ft.) in diameter. The turn table is flush with the raised floor of the chamber in order to maintain its function as a ground plane. An 80cm high PVC support structure is placed on top of the turntable.

For all measurements, the spectrum was scanned through all EUT azimuths and from 1 to 4 meter receive antenna height using a broadband antenna from 30MHz up to the upper frequency shown in 15.33(b)(1) depending on the highest frequency generated or used in the device or on which the device operates or tunes. For frequencies above 1GHz, linearly polarized double ridge horn antennas were used. For frequencies below 30MHz, a calibrated loop antenna was used. When exploratory measurements were necessary, they were performed at 1 meter test distance inside the semi-anechoic chamber using broadband antennas, broadband amplifiers, and spectrum analyzers to determine the frequencies and modes producing the maximum emissions. Sufficient time for the EUT, support equipment, and test equipment was allowed in order for them to warm up to their normal operating condition. The test set-up for frequencies below 1GHz was placed on top of the 0.8 meter high, 1 x 1.5 meter table; and test set-up for frequencies 1-40GHz was placed on top of the 1.5 meter high, 1 x 1.5 meter table. The EUT, support equipment, and interconnecting cables were arranged and manipulated to maximize each emission. Appropriate precaution was taken to ensure that all emissions from the EUT were maximized and investigated. The system configuration, clock speed, mode of operation or video resolution, if applicable, turntable azimuth, and receive antenna height was noted for each frequency found.

Final measurements were made in the semi-anechoic chamber using calibrated, linearly polarized broadband and horn antennas. The test setup was configured to the setup that produced the worst case emissions. The spectrum analyzer was set to investigate all frequencies required for testing to compare the highest radiated disturbances with respect to the specified limits. The turntable

containing the EUT was rotated through 360 degrees and the height of the receive antenna was varied 1 to 4 meters and stopped at the azimuth and height producing the maximum emission. Each emission was maximized by changing the orientation of the EUT through three orthogonal planes and changing the polarity of the receive antenna, which produced the worst-case emissions. According to 3dB Beam-Width of horn antenna, the horn antenna should be always directed to the EUT when rising height.

4. TEST EQUIPMENT CALIBRATION DATE

Radiated Emissions

Instrument	Brand	Type No.	Asset No.	Cali. Interval	Cali. Due Date
Broadband TRILOG Antenna	SCHWARZBECK	VULB 9162	MRTTWA00001	1 year	2021/10/05
Active Loop Antenna	SCHWARZBECK	FMZB 1519B	MRTTWA00002	1 year	2021/04/27
Broadband Hornantenna	SCHWARZBECK	BBHA 9120D	MRTTWA00003	1 year	2021/04/24
Breitband Hornantenna	SCHWARZBECK	BBHA 9170	MRTTWA00004	1 year	2021/04/24
Broadband Preamplifier	SCHWARZBECK	BBV 9718	MRTTWA00005	1 year	2021/04/24
Broadband Amplifier	SCHWARZBECK	BBV 9721	MRTTWA00006	1 year	2021/04/24
Signal Analyzer	R&S	FSV40	MRTTWA00007	1 year	2021/03/24
EMI Test Receiver	R&S	ESR3	MRTTWA00009	1 year	2021/03/25
EXA Signal Analyzer	KEYSIGHT	N9010A	MRTTWA00012	1 year	2021/11/02
EXA Signal Analyzer	KEYSIGHT	N9010B	MRTTWA00074	1 year	2021/07/14
Antenna Cable	HUBERSUHNER	SF106	MRTTWE00010	1 year	2021/06/16
Temperature/Humidity Meter	TFA	35.1078.10.IT	MRTTWA00032	1 year	2021/05/28

Conducted Test Equipment

Instrument	Brand	Type No.	Asset No.	Cali. Interval	Cali. Due Date
X-Series USB Peak and Average Power Sensor	KEYSIGHT	U2021XA	MRTTWA00014	1 year	2021/04/24
EXA Signal Analyzer	KEYSIGHT	N9010A	MRTTWA00012	1 year	2021/11/02
EXA Signal Analyzer	KEYSIGHT	N9010B	MRTTWA00074	1 year	2021/07/11
Temperature & Humidity Chamber	TEN BILLION	TTH-B3UP	MRTTWA00036	1 year	2021/06/10
Temperature/Humidity Meter	TFA	35.1078.10.IT	MRTTWA00033	1 year	2021/05/28

Software	Version	Function
EMI Software	V3	EMI Test Software

5. MEASUREMENT UNCERTAINTY

Where relevant, the following test uncertainty levels have been estimated for tests performed on the EUT as specified in CISPR 16-4-2. This uncertainty represents an expanded uncertainty expressed at approximately the 95% confidence level using a coverage factor of $k = 2$.

Conducted Measurement
Measuring Uncertainty for a Level of Confidence of 95% ($U=2Uc(y)$): 2.65dB
Radiated Emission Measurement
Measuring Uncertainty for a Level of Confidence of 95% ($U=2Uc(y)$): 9kHz ~ 30MHz: 3.92dB 30MHz ~ 1GHz: 4.25dB 1GHz ~ 18GHz: 4.40dB

6. TEST RESULT

6.1. Summary

FCC Section(s)	Test Description	Test Limit	Test Condition	Test Result	Reference
2.1046; 24.232(a)(2) 27.50(d)(2)	Equivalent Isotropically Radiated Power	Refer to Section 6.2	Conducted & Radiated	Pass	Section 6.2
2.1055; 24.235;27.54	Frequency Stability	Refer to Section 6.3	Conducted	Pass	Section 6.3
2.1049	Emission Bandwidth	Refer to Section 6.4		Pass	Section 6.4
24.238(a) 27.53(h)	Band Edge Measurements	Refer to Section 6.5		Pass	Section 6.5
2.1046; 24.232(d) 27.50(d)(5)	Peak to Average Ratio	Refer to Section 6.6		Pass	Section 6.6
2.1051; 24.238(a) 27.53(h)	Conducted Spurious Emissions	Refer to Section 6.7		Pass	Section 6.7
2.1053; 24.238(a) 27.53(h)	Radiated Spurious Emissions	Refer to Section 6.8	Radiated	Pass	Section 6.8

Notes:

- 1) The analyzer plots shown in this section were all taken with a correction table loaded into the analyzer. The correction table was used to account for the losses of the cables and attenuators used as part of the system to connect the EUT to the analyzer at all frequencies of interest.
- 2) The Emission Bandwidth, Frequency Stability, Channel Band-edge, Conducted Emission and Radiated Emission were presented the worst test data of modulation & antenna port in the test report.

6.2. Equivalent Isotropically Radiated Power Measurement

6.2.1. Test Limit

The Radiated Equivalent Isotropically Power shall be according to the specific rule Part 24.232(a)(2) & 27.50(d)(2) that are limited to EIRP of 1640 watts/MHz when transmitting with an emission bandwidth greater than 1 MHz.

6.2.2. Test Procedures Used

KDB 971168 D01v03r01 - Section 5.2.4 & 5.8

ANSI C63.26-2015 - Section 5.2.4.2 & 5.2.7

6.2.3. Test Setting

Average Power Measurement

Average power measurements were performed only when the EUT was transmitting at its maximum power control level using a broadband power meter with a pulse sensor. The power meter implemented triggering and gating capabilities which were set up such that power measurements were recorded only during the ON time of the transmitter.

Radiated Equivalent Isotropically Power Measurement

1. $RBW \geq OBW$
2. $VBW \geq 3 \cdot RBW$
3. Sweep time $\geq 10 \times$ (number of points in sweep) \times (transmission symbol period)
4. Detector = power averaging (rms)
5. Set sweep trigger to "free run"
6. If the EUT can be configured to transmit continuously, then set the trigger to free run
7. Trace average at least 100 traces in power averaging (rms) mode if sweep is set to auto-couple.
To accurately determine the average power over the on and off time of the transmitter, it can be necessary to increase the number of traces to be averaged above 100, or if using a manually configured sweep time, increase the sweep time
8. The trace was allowed to stabilize
9. Use the peak marker function to determine the peak amplitude level.
10. $EIRP = \text{Output Power Level of S.G} - T_x \text{ Cable Loss} + \text{Antenna Gain of Substitution Antenna.}$

6.2.4. Test Setup

Conducted Measurement of Output Power

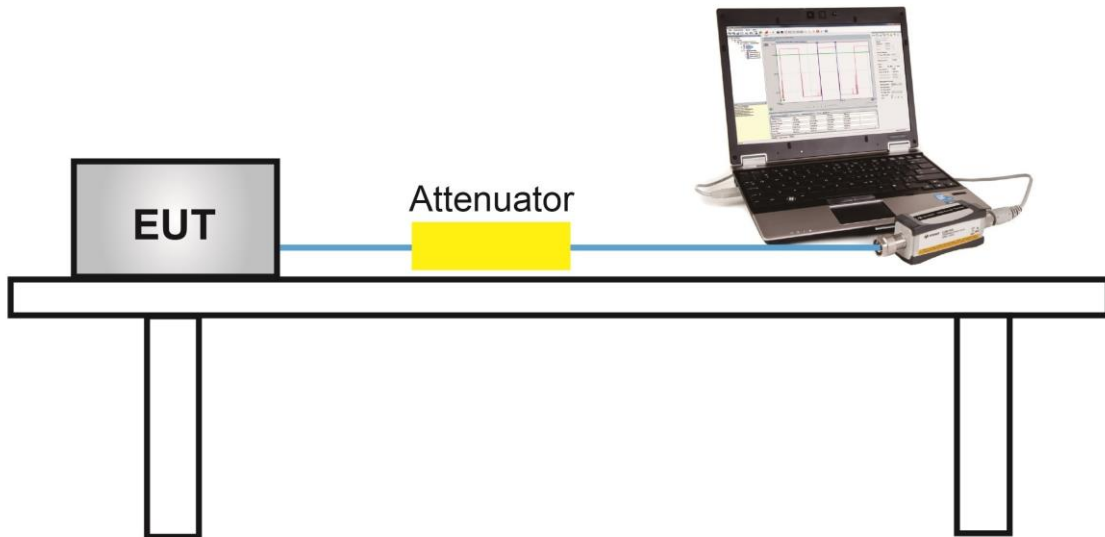

Radiated Measurement of Equivalent Isotropically Radiated Power

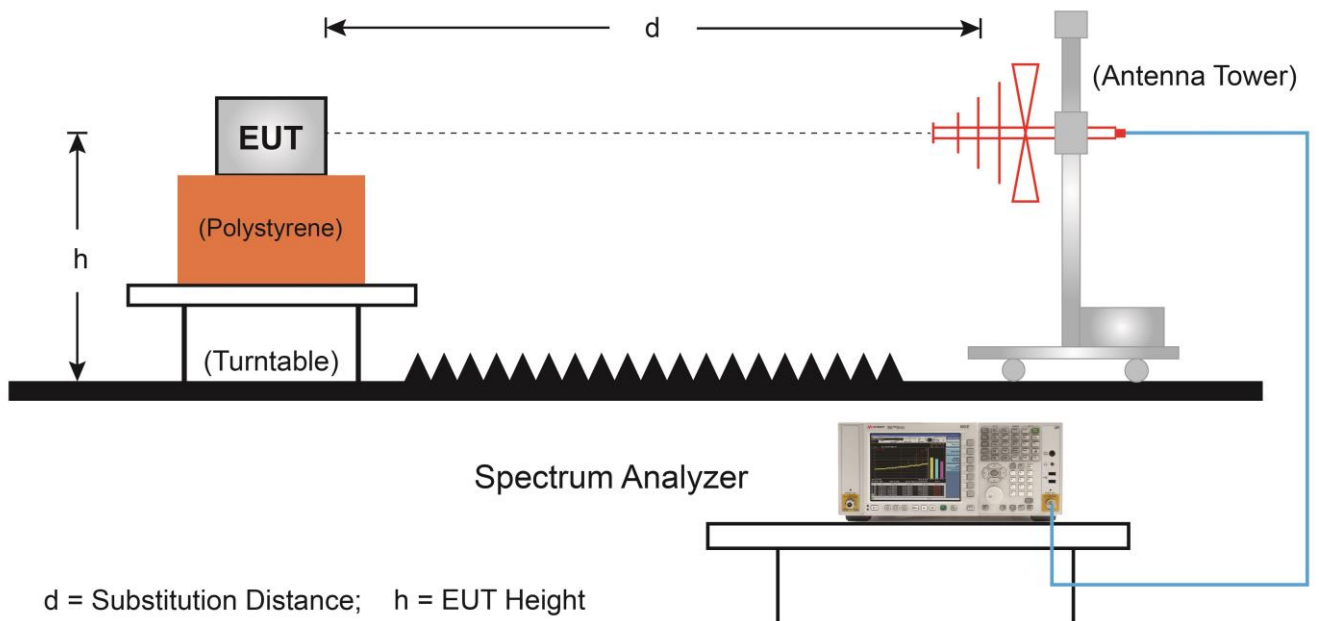

6.2.5. Test Result

Product	AirScale Indoor Radio ASiR-pRRH	Test Engineer	Peter Xu
Test Site	SR2	Test Date	2020/11/18 ~ 2020/11/23
Test Configuration	n25 (Single Carrier)		

Frequency (MHz)	Channel Bandwidth (MHz)	Ant 0 Power (dBm)	Ant 1 Power (dBm)	Total Power (dBm)
QPSK				
1932.5	5	23.01	23.24	26.14
1962.5	5	22.78	22.98	25.89
1992.5	5	23.22	23.74	26.50
1935.0	10	23.24	23.55	26.41
1962.5	10	22.74	22.97	25.87
1990.0	10	23.01	23.24	26.14
1937.5	15	23.18	23.58	26.39
1962.5	15	22.76	22.92	25.85
1987.5	15	23.21	23.64	26.44
1940.0	20	23.26	23.31	26.30
1962.5	20	22.86	22.96	25.92
1985.0	20	23.21	23.49	26.36
16QAM				
1932.5	5	22.83	23.09	25.97
1962.5	5	23.10	22.96	26.04
1992.5	5	23.20	23.54	26.38
1935.0	10	23.01	23.29	26.16
1962.5	10	22.73	22.69	25.72
1990.0	10	22.89	23.11	26.01
1937.5	15	23.10	23.50	26.31
1962.5	15	22.68	22.89	25.80
1987.5	15	23.12	23.22	26.18
1940.0	20	23.28	23.39	26.35
1962.5	20	22.91	22.94	25.94
1985.0	20	23.22	23.28	26.26

Frequency (MHz)	Channel Bandwidth (MHz)	Ant 0 Power (dBm)	Ant 1 Power (dBm)	Total Power (dBm)
64QAM				
1932.5	5	22.98	23.15	26.08
1962.5	5	22.97	23.13	26.06
1992.5	5	23.56	23.65	26.62
1935.0	10	23.12	23.66	26.41
1962.5	10	22.93	23.00	25.98
1990.0	10	23.06	23.26	26.17
1937.5	15	23.23	23.59	26.42
1962.5	15	22.82	22.88	25.86
1987.5	15	23.19	23.54	26.38
1940.0	20	23.32	23.44	26.39
1962.5	20	22.96	23.01	26.00
1985.0	20	23.29	23.59	26.45
256QAM				
1932.5	5	22.86	23.21	26.05
1962.5	5	23.01	23.04	26.04
1992.5	5	23.47	23.84	26.67
1935.0	10	23.19	23.43	26.32
1962.5	10	22.81	22.98	25.91
1990.0	10	22.99	23.29	26.15
1937.5	15	23.20	23.56	26.39
1962.5	15	22.86	23.03	25.96
1987.5	15	23.20	23.65	26.44
1940.0	20	23.34	23.45	26.41
1962.5	20	22.97	23.02	26.01
1985.0	20	23.33	23.61	26.48

Note: Total Power (dBm) = $10 \cdot \log \{ 10^{[ANT\ 0\ Power\ (dBm) / 10]} + 10^{[ANT\ 1\ Power\ (dBm) / 10]} \}$ (dBm).

Product	AirScale Indoor Radio ASiR-pRRH	Test Engineer	Peter Xu
Test Site	SR2	Test Date	2020/11/18 ~ 2020/11/23
Test Configuration	n66 (Single Carrier)		

Frequency (MHz)	Channel Bandwidth (MHz)	Ant 0 Power (dBm)	Ant 1 Power (dBm)	Total Power (dBm)
QPSK				
2112.5	5	23.19	22.53	25.88
2145.0	5	23.05	22.77	25.92
2177.5	5	23.42	22.71	26.09
2115.0	10	23.43	22.71	26.10
2145.0	10	23.27	22.75	26.03
2175.0	10	23.63	23.01	26.34
2117.5	15	23.59	22.68	26.17
2145.0	15	23.11	22.85	25.99
2172.5	15	23.21	23.53	26.38
2120.0	20	23.61	22.57	26.13
2145.0	20	23.48	22.73	26.13
2170.0	20	23.78	22.92	26.38
16QAM				
2112.5	5	23.45	22.55	26.03
2145.0	5	23.09	22.78	25.95
2177.5	5	23.42	22.95	26.20
2115.0	10	23.41	22.67	26.07
2145.0	10	23.22	22.71	25.98
2175.0	10	23.57	22.96	26.29
2117.5	15	23.49	22.64	26.10
2145.0	15	23.12	22.83	25.99
2172.5	15	23.14	23.52	26.34
2120.0	20	23.65	22.89	26.30
2145.0	20	23.41	22.79	26.12
2170.0	20	23.84	22.97	26.44

Frequency (MHz)	Channel Bandwidth (MHz)	Ant 0 Power (dBm)	Ant 1 Power (dBm)	Total Power (dBm)
64QAM				
2112.5	5	23.63	22.73	26.21
2145.0	5	23.28	22.93	26.12
2177.5	5	23.59	23.11	26.37
2115.0	10	23.54	22.79	26.19
2145.0	10	23.28	22.83	26.07
2175.0	10	23.69	23.08	26.41
2117.5	15	23.58	22.62	26.14
2145.0	15	23.19	22.85	26.03
2172.5	15	23.21	23.56	26.40
2120.0	20	23.74	22.94	26.37
2145.0	20	23.45	23.03	26.26
2170.0	20	23.87	23.02	26.48
256QAM				
2112.5	5	23.53	22.61	26.10
2145.0	5	23.16	22.82	26.00
2177.5	5	23.49	23.04	26.28
2115.0	10	23.43	22.71	26.10
2145.0	10	23.21	22.73	25.99
2175.0	10	23.61	22.98	26.32
2117.5	15	23.58	22.61	26.13
2145.0	15	23.16	22.86	26.02
2172.5	15	23.19	23.52	26.37
2120.0	20	23.74	22.94	26.37
2145.0	20	23.46	23.01	26.25
2170.0	20	23.89	23.03	26.49

Note: Total Power (dBm) = $10 \cdot \log \{ 10^{[ANT 0 \text{ Power (dBm) / 10}]} + 10^{[ANT 1 \text{ Power (dBm) / 10}]} \}$ (dBm).

Product	AirScale Indoor Radio ASiR-pRRH	Test Engineer	Peter Xu
Test Site	SR2	Test Date	2020/11/18 ~ 2020/11/23
Test Configuration	n66 (Multi Carrier)		

Frequency (MHz)	Channel Bandwidth (MHz)	Ant 0 Power (dBm)	Ant 1 Power (dBm)	Total Power (dBm)
QPSK				
2112.5 + 2117.5	5 + 5	23.52	22.14	25.89
2142.5 + 2147.5	5 + 5	23.24	22.45	25.87
2172.5 + 2177.5	5 + 5	23.57	22.56	26.10
2115.0 + 2125.0	10 + 10	23.72	22.38	26.11
2140.0 + 2150.0	10 + 10	23.22	22.42	25.85
2165.0 + 2175.0	10 + 10	23.70	22.63	26.21
2117.5 + 2132.5	15 + 15	24.03	22.43	26.31
2137.5 + 2152.5	15 + 15	23.16	23.16	26.17
2157.5 + 2172.5	15 + 15	23.48	22.96	26.24
2120.0 + 2140.0	20 + 20	23.32	22.88	26.12
2135.0 + 2155.0	20 + 20	23.06	22.94	26.01
2150.0 + 2170.0	20 + 20	23.14	22.95	26.06
16QAM				
2112.5 + 2117.5	5 + 5	23.62	22.26	26.00
2142.5 + 2147.5	5 + 5	23.37	22.49	25.96
2172.5 + 2177.5	5 + 5	23.66	22.61	26.18
2115.0 + 2125.0	10 + 10	23.64	22.03	25.92
2140.0 + 2150.0	10 + 10	23.20	22.39	25.82
2165.0 + 2175.0	10 + 10	23.67	22.52	26.14
2117.5 + 2132.5	15 + 15	24.01	22.30	26.25
2137.5 + 2152.5	15 + 15	23.06	22.90	25.99
2157.5 + 2172.5	15 + 15	23.47	23.01	26.26
2120.0 + 2140.0	20 + 20	23.41	22.97	26.21
2135.0 + 2155.0	20 + 20	22.93	22.69	25.82
2150.0 + 2170.0	20 + 20	23.30	23.09	26.21

Frequency (MHz)	Channel Bandwidth (MHz)	Ant 0 Power (dBm)	Ant 1 Power (dBm)	Total Power (dBm)
64QAM				
2112.5 + 2117.5	5 + 5	23.65	22.31	26.04
2142.5 + 2147.5	5 + 5	23.51	22.63	26.10
2172.5 + 2177.5	5 + 5	23.75	22.67	26.25
2115.0 + 2125.0	10 + 10	23.71	22.41	26.12
2140.0 + 2150.0	10 + 10	23.35	22.52	25.97
2165.0 + 2175.0	10 + 10	22.75	22.61	25.69
2117.5 + 2132.5	15 + 15	24.06	22.38	26.31
2137.5 + 2152.5	15 + 15	23.25	22.81	26.05
2157.5 + 2172.5	15 + 15	23.39	22.93	26.18
2120.0 + 2140.0	20 + 20	23.61	22.90	26.28
2135.0 + 2155.0	20 + 20	23.09	22.74	25.93
2150.0 + 2170.0	20 + 20	23.32	23.10	26.22
256QAM				
2112.5 + 2117.5	5 + 5	23.52	22.28	25.95
2142.5 + 2147.5	5 + 5	23.33	22.52	25.95
2172.5 + 2177.5	5 + 5	23.75	22.62	26.23
2115.0 + 2125.0	10 + 10	23.73	22.27	26.07
2140.0 + 2150.0	10 + 10	23.22	22.42	25.85
2165.0 + 2175.0	10 + 10	23.68	22.61	26.19
2117.5 + 2132.5	15 + 15	24.04	22.44	26.32
2137.5 + 2152.5	15 + 15	23.09	22.88	26.00
2157.5 + 2172.5	15 + 15	23.34	22.99	26.18
2120.0 + 2140.0	20 + 20	23.00	22.89	25.96
2135.0 + 2155.0	20 + 20	23.01	22.88	25.96
2150.0 + 2170.0	20 + 20	23.28	23.01	26.16

Note: Total Power (dBm) = $10 \cdot \log \{ 10^{[ANT 0 \text{ Power (dBm) / 10}] + 10^{[ANT 1 \text{ Power (dBm) / 10}]} \}$ (dBm).

Product	AirScale Indoor Radio ASiR-pRRH	Test Engineer	Peter Xu
Test Site	AC1	Test Date	2020/11/18 ~ 2020/11/23
Test Configuration	n25 (Single Carrier)		

Frequency (MHz)	Channel Bandwidth (MHz)	Reading Level (dBm)	Factor (dB)	EIRP (dBm)	Limit (dBm)
QPSK					
1932.5	5	26.12	4.97	31.09	< 62.15
1962.5	5	25.85	4.97	30.82	< 62.15
1992.5	5	25.34	6.02	31.36	< 62.15
1935.0	10	24.75	4.90	29.65	< 62.15
1962.5	10	25.07	4.97	30.04	< 62.15
1990.0	10	25.18	5.93	31.11	< 62.15
1937.5	15	25.17	4.82	29.99	< 62.15
1962.5	15	25.42	4.97	30.39	< 62.15
1987.5	15	24.98	5.84	30.82	< 62.15
1940.0	20	26.09	4.76	30.85	< 62.15
1962.5	20	25.94	4.97	30.91	< 62.15
1985.0	20	25.72	5.76	31.48	< 62.15
16QAM					
1932.5	5	25.28	4.97	30.25	< 62.15
1962.5	5	25.45	4.97	30.42	< 62.15
1992.5	5	24.46	6.02	30.48	< 62.15
1935.0	10	24.96	4.90	29.86	< 62.15
1962.5	10	25.00	4.97	29.97	< 62.15
1990.0	10	24.89	5.93	30.82	< 62.15
1937.5	15	25.27	4.82	30.09	< 62.15
1962.5	15	25.94	4.97	30.91	< 62.15
1987.5	15	24.89	5.84	30.73	< 62.15
1940.0	20	25.81	4.76	30.57	< 62.15
1962.5	20	25.74	4.97	30.71	< 62.15
1985.0	20	25.16	5.76	30.92	< 62.15

Frequency (MHz)	Channel Bandwidth (MHz)	Reading Level (dBm)	Factor (dB)	EIRP (dBm)	Limit (dBm)
64QAM					
1932.5	5	25.06	4.97	30.03	< 62.15
1962.5	5	25.17	4.97	30.14	< 62.15
1992.5	5	24.32	6.02	30.34	< 62.15
1935.0	10	24.63	4.90	29.53	< 62.15
1962.5	10	24.11	4.97	29.08	< 62.15
1990.0	10	24.07	5.93	30.00	< 62.15
1937.5	15	25.14	4.82	29.96	< 62.15
1962.5	15	25.68	4.97	30.65	< 62.15
1987.5	15	24.84	5.84	30.68	< 62.15
1940.0	20	25.14	4.76	29.90	< 62.15
1962.5	20	25.07	4.97	30.04	< 62.15
1985.0	20	24.56	5.76	30.32	< 62.15
256QAM					
1932.5	5	24.95	4.97	29.92	< 62.15
1962.5	5	25.25	4.97	30.22	< 62.15
1992.5	5	24.24	6.02	30.26	< 62.15
1935.0	10	25.38	4.90	30.28	< 62.15
1962.5	10	23.94	4.97	28.91	< 62.15
1990.0	10	24.71	5.93	30.64	< 62.15
1937.5	15	25.22	4.82	30.04	< 62.15
1962.5	15	24.66	4.97	29.63	< 62.15
1987.5	15	24.20	5.84	30.04	< 62.15
1940.0	20	24.97	4.76	29.73	< 62.15
1962.5	20	25.13	4.97	30.10	< 62.15
1985.0	20	24.57	5.76	30.33	< 62.15

Product	AirScale Indoor Radio ASiR-pRRH	Test Engineer	Peter Xu
Test Site	AC1	Test Date	2020/11/18 ~ 2020/11/23
Test Configuration	n66 (Single Carrier)		

Frequency (MHz)	Channel Bandwidth (MHz)	Reading Level (dBm)	Factor (dB)	EIRP (dBm)	Limit (dBm)
QPSK					
2112.5	5	25.81	6.01	31.82	< 62.15
2145.0	5	25.89	6.39	32.28	< 62.15
2177.5	5	25.53	6.28	31.81	< 62.15
2115.0	10	25.34	6.04	31.38	< 62.15
2145.0	10	25.69	6.39	32.08	< 62.15
2175.0	10	25.66	6.30	31.96	< 62.15
2117.5	15	25.34	6.07	31.41	< 62.15
2145.0	15	25.75	6.39	32.14	< 62.15
2172.5	15	25.44	6.32	31.76	< 62.15
2120.0	20	26.30	6.10	32.40	< 62.15
2145.0	20	25.52	6.39	31.91	< 62.15
2170.0	20	25.80	6.34	32.14	< 62.15
16QAM					
2112.5	5	25.61	6.01	31.62	< 62.15
2145.0	5	25.59	6.39	31.98	< 62.15
2177.5	5	25.47	6.28	31.75	< 62.15
2115.0	10	24.97	6.04	31.01	< 62.15
2145.0	10	25.81	6.39	32.20	< 62.15
2175.0	10	25.89	6.30	32.19	< 62.15
2117.5	15	24.98	6.07	31.05	< 62.15
2145.0	15	25.89	6.39	32.28	< 62.15
2172.5	15	25.62	6.32	31.94	< 62.15
2120.0	20	24.91	6.10	31.01	< 62.15
2145.0	20	25.03	6.39	31.42	< 62.15
2170.0	20	25.57	6.34	31.91	< 62.15

Frequency (MHz)	Channel Bandwidth (MHz)	Reading Level (dBm)	Factor (dB)	EIRP (dBm)	Limit (dBm)
64QAM					
2112.5	5	25.29	6.01	31.30	< 62.15
2145.0	5	25.63	6.39	32.02	< 62.15
2177.5	5	25.04	6.28	31.32	< 62.15
2115.0	10	25.10	6.04	31.14	< 62.15
2145.0	10	25.58	6.39	31.97	< 62.15
2175.0	10	24.96	6.30	31.26	< 62.15
2117.5	15	25.15	6.07	31.22	< 62.15
2145.0	15	24.64	6.39	31.03	< 62.15
2172.5	15	25.42	6.32	31.74	< 62.15
2120.0	20	25.30	6.10	31.40	< 62.15
2145.0	20	24.82	6.39	31.21	< 62.15
2170.0	20	25.34	6.34	31.68	< 62.15
256QAM					
2112.5	5	24.98	6.01	30.99	< 62.15
2145.0	5	24.62	6.39	31.01	< 62.15
2177.5	5	25.01	6.28	31.29	< 62.15
2115.0	10	24.77	6.04	30.81	< 62.15
2145.0	10	24.83	6.39	31.22	< 62.15
2175.0	10	24.65	6.30	30.95	< 62.15
2117.5	15	24.94	6.07	31.01	< 62.15
2145.0	15	24.70	6.39	31.09	< 62.15
2172.5	15	24.47	6.32	30.79	< 62.15
2120.0	20	24.84	6.10	30.94	< 62.15
2145.0	20	24.90	6.39	31.29	< 62.15
2170.0	20	24.62	6.34	30.96	< 62.15

Product	AirScale Indoor Radio ASiR-pRRH	Test Engineer	Peter Xu
Test Site	AC1	Test Date	2020/11/18 ~ 2020/11/23
Test Configuration	n66 (Multi Carrier)		

Frequency (MHz)	Channel Bandwidth (MHz)	Reading Level (dBm)	Factor (dB)	EIRP (dBm)	Limit (dBm)
QPSK					
2112.5 + 2117.5	5 + 5	25.28	6.04	31.32	< 62.15
2140.0 + 2145.0	5 + 5	24.70	6.37	31.07	< 62.15
2172.5 + 2177.5	5 + 5	25.83	6.30	32.13	< 62.15
2115.0 + 2125.0	10 + 10	24.84	6.10	30.94	< 62.15
2135.0 + 2145.0	10 + 10	24.66	6.36	31.02	< 62.15
2165.0 + 2175.0	10 + 10	25.62	6.34	31.96	< 62.15
2117.5 + 2132.5	15 + 15	25.30	6.17	31.47	< 62.15
2130.0 + 2145.0	15 + 15	24.85	6.33	31.18	< 62.15
2157.5 + 2172.5	15 + 15	26.05	6.38	32.43	< 62.15
2120.0 + 2140.0	20 + 20	24.76	6.23	30.99	< 62.15
2125.0 + 2145.0	20 + 20	25.35	6.30	31.65	< 62.15
2150.0 + 2170.0	20 + 20	25.60	6.42	32.02	< 62.15
16QAM					
2112.5 + 2117.5	5 + 5	25.40	6.04	31.44	< 62.15
2140.0 + 2145.0	5 + 5	24.78	6.37	31.15	< 62.15
2172.5 + 2177.5	5 + 5	25.92	6.30	32.22	< 62.15
2115.0 + 2125.0	10 + 10	25.15	6.10	31.25	< 62.15
2135.0 + 2145.0	10 + 10	25.13	6.36	31.49	< 62.15
2165.0 + 2175.0	10 + 10	25.83	6.34	32.17	< 62.15
2117.5 + 2132.5	15 + 15	25.24	6.17	31.41	< 62.15
2130.0 + 2145.0	15 + 15	24.67	6.33	31.00	< 62.15
2157.5 + 2172.5	15 + 15	25.03	6.38	31.41	< 62.15
2120.0 + 2140.0	20 + 20	24.79	6.23	31.02	< 62.15
2125.0 + 2145.0	20 + 20	24.26	6.30	30.56	< 62.15
2150.0 + 2170.0	20 + 20	24.69	6.42	31.11	< 62.15

Frequency (MHz)	Channel Bandwidth (MHz)	Reading Level (dBm)	Factor (dB)	EIRP (dBm)	Limit (dBm)
64QAM					
2112.5 + 2117.5	5 + 5	25.40	6.04	31.44	< 62.15
2140.0 + 2145.0	5 + 5	24.93	6.37	31.30	< 62.15
2172.5 + 2177.5	5 + 5	25.98	6.30	32.28	< 62.15
2115.0 + 2125.0	10 + 10	25.34	6.10	31.44	< 62.15
2135.0 + 2145.0	10 + 10	25.28	6.36	31.64	< 62.15
2165.0 + 2175.0	10 + 10	25.12	6.34	31.46	< 62.15
2117.5 + 2132.5	15 + 15	25.28	6.17	31.45	< 62.15
2130.0 + 2145.0	15 + 15	24.73	6.33	31.06	< 62.15
2157.5 + 2172.5	15 + 15	24.93	6.38	31.31	< 62.15
2120.0 + 2140.0	20 + 20	24.60	6.23	30.83	< 62.15
2125.0 + 2145.0	20 + 20	24.30	6.30	30.60	< 62.15
2150.0 + 2170.0	20 + 20	24.66	6.42	31.08	< 62.15
256QAM					
2112.5 + 2117.5	5 + 5	25.36	6.04	31.40	< 62.15
2140.0 + 2145.0	5 + 5	24.79	6.37	31.16	< 62.15
2172.5 + 2177.5	5 + 5	24.97	6.30	31.27	< 62.15
2115.0 + 2125.0	10 + 10	25.29	6.10	31.39	< 62.15
2135.0 + 2145.0	10 + 10	25.16	6.36	31.52	< 62.15
2165.0 + 2175.0	10 + 10	25.00	6.34	31.34	< 62.15
2117.5 + 2132.5	15 + 15	25.31	6.17	31.48	< 62.15
2130.0 + 2145.0	15 + 15	24.77	6.33	31.10	< 62.15
2157.5 + 2172.5	15 + 15	24.69	6.38	31.07	< 62.15
2120.0 + 2140.0	20 + 20	24.47	6.23	30.70	< 62.15
2125.0 + 2145.0	20 + 20	24.36	6.30	30.66	< 62.15
2150.0 + 2170.0	20 + 20	24.70	6.42	31.12	< 62.15

6.3. Frequency Stability Measurement

6.3.1. Test Limit

N/A

6.3.2. Test Procedures Used

KDB 971168 D01v03r01 - Section 9

ANSI C63.26-2015 - Section 5.6

6.3.3. Test Setting

Frequency Stability Under Temperature Variations:

The equipment under test was connected to an external AC or DC power supply and input rated voltage. RF output was connected to a frequency counter or spectrum analyzer via feed through attenuators. The EUT was placed inside the temperature chamber. Set the spectrum analyzer RBW low enough to obtain the desired frequency resolution and measure EUT 20°C operating frequency as reference frequency. Turn EUT off and set the chamber temperature to highest. After the temperature stabilized for approximately 30 minutes recorded the frequency. Repeat step measure with 10°C decreased per stage until the lowest temperature reached.

Frequency Stability Under Voltage Variations:

Set chamber temperature to 20°C. Use a variable AC power supply / DC power source to power the EUT and set the voltage to rated voltage. Set the spectrum analyzer RBW low enough to obtain the desired frequency resolution and recorded the frequency.

Reduce the input voltage to specify extreme voltage variation ($\pm 15\%$) and endpoint (If a product is specified to operate over a range of input voltage then the -15% variation is applied to the lowermost voltage and the $+15\%$ is applied to the uppermost voltage), record the maximum frequency change.

6.3.4. Test Setup

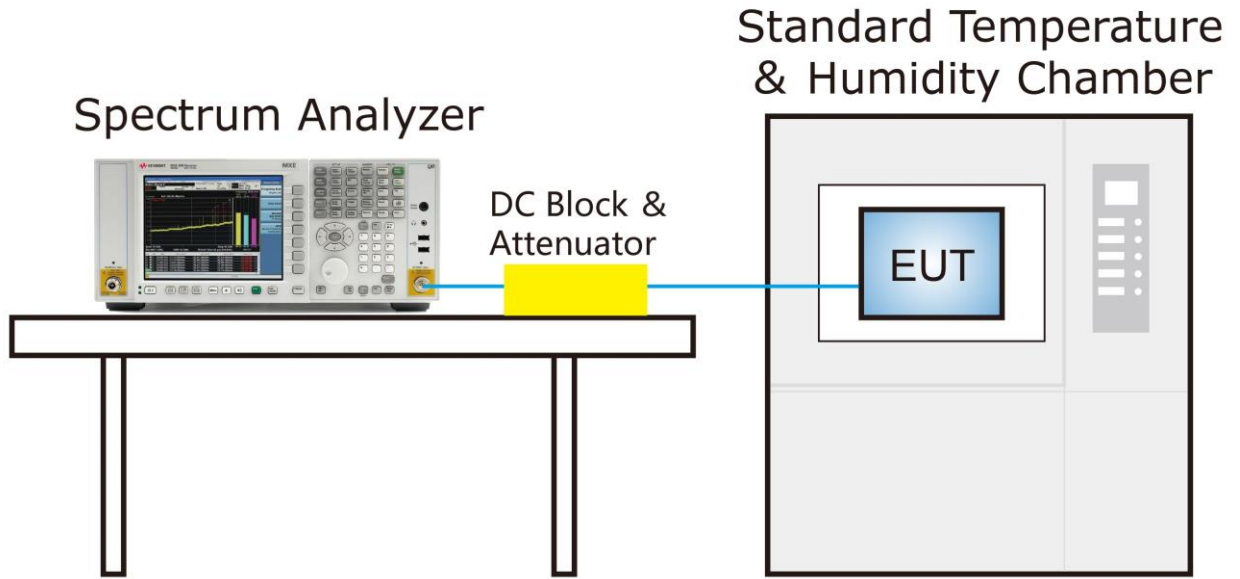

6.3.5. Test Result

Product	AirScale Indoor Radio ASiR-pRRH	Test Engineer	Peter Xu
Test Site	SR2	Test Date	2020/11/22
Test Confirmation	n25(Single Carrier)		

Voltage (DC)	Temp (°C)	Frequency Tolerance (ppm)
54V	- 30	-0.0535
	- 20	-0.0536
	- 10	-0.0535
	0	-0.0523
	+ 10	-0.0526
	+ 20	-0.0524
	+ 30	-0.0522
	+ 40	-0.0524
	+ 50	-0.0522
57V	+ 20	-0.0520
52V	+ 20	-0.0522

Product	AirScale Indoor Radio ASiR-pRRH	Test Engineer	Peter Xu
Test Site	SR2	Test Date	2020/11/16
Test Confirmation	n66 (Single Carrier)		

Voltage (DC)	Temp (°C)	Frequency Tolerance (ppm)
54V	- 30	-0.0558
	- 20	-0.0557
	- 10	-0.0559
	0	-0.0557
	+ 10	-0.0554
	+ 20	-0.0556
	+ 30	-0.0553
	+ 40	-0.0554
	+ 50	-0.0557
57V	+ 20	-0.0557
52V	+ 20	-0.0553

6.4. Emission Bandwidth

6.4.1. Test Limit

The emission bandwidth is defined as the width of the signal between two points, one below the carrier center frequency and one above the carrier center frequency, outside of which all emissions are attenuated at least 26 dB below the transmitter power.

6.4.2. Test Procedure

KDB 971168 D01v03r01 - Section 4.1 & 4.2

ANSI C63.26-2015 - Section 5.4.3 & 5.4.4

6.4.3. Test Setting

1. Set center frequency to the nominal EUT channel center frequency;
2. RBW = The nominal RBW shall be in the range of 1% to 5% of the anticipated OBW;
3. VBW $\geq 3 \times$ RBW;
4. Detector = Peak;
5. Trace mode = max hold;
6. Sweep = auto couple;
7. Allow the trace to stabilize;
8. The dynamic range of the spectrum analyzer at the selected RBW shall be more than 10 dB below the target “-X dB” requirement, i.e., if the requirement calls for measuring the -26 dB OBW, the spectrum analyzer noise floor at the selected RBW shall be at least 26 dB below the reference level

6.4.4. Test Setup

Spectrum Analyzer

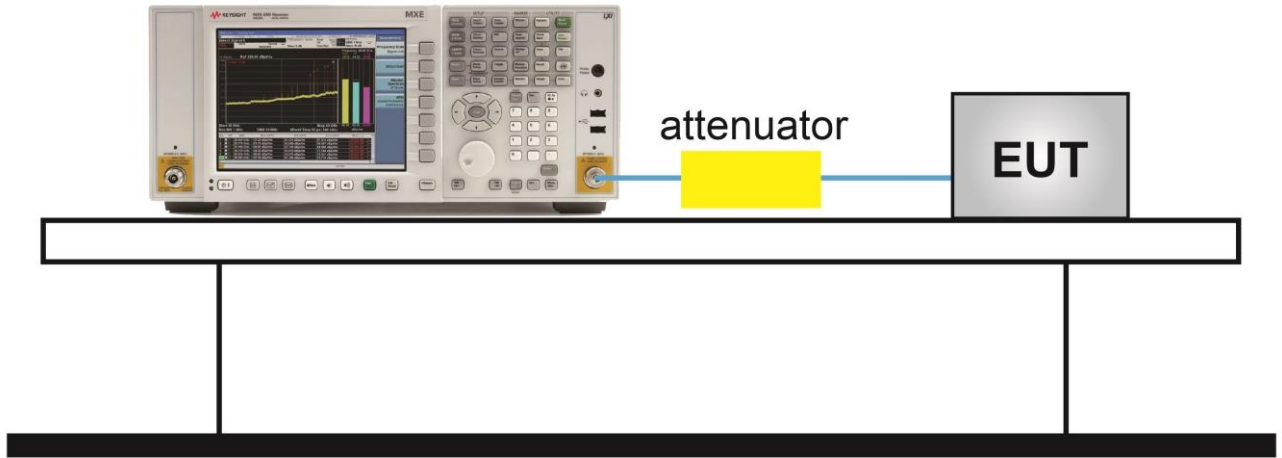

6.4.5. Test Result

Product	AirScale Indoor Radio ASiR-pRRH	Test Engineer	Peter Xu
Test Site	SR2	Test Date	2020/11/22 ~ 2020/11/23
Test Configuration	n25 (Single Carrier)		

Frequency (MHz)	Bandwidth (MHz)	26dB Bandwidth (MHz)	99% Bandwidth (MHz)
QPSK			
1932.5	5	4.96	4.52
1962.5	5	4.98	4.57
1992.5	5	4.99	4.54
1935.0	10	9.92	9.23
1962.5	10	9.89	9.21
1990.0	10	9.91	9.19
1937.5	15	14.93	14.16
1962.5	15	15.03	14.21
1987.5	15	15.03	14.24
1940.0	20	19.98	18.94
1962.5	20	19.99	18.99
1985.0	20	20.07	19.06
16QAM			
1932.5	5	4.97	4.54
1962.5	5	4.95	4.53
1992.5	5	4.93	4.50
1935.0	10	9.91	9.24
1962.5	10	9.89	9.24
1990.0	10	9.93	9.26
1937.5	15	14.95	14.16
1962.5	15	15.05	14.19
1987.5	15	15.06	14.22
1940.0	20	20.03	18.97
1962.5	20	20.02	19.01
1985.0	20	20.06	19.09

Frequency (MHz)	Bandwidth (MHz)	26dB Bandwidth (MHz)	99% Bandwidth (MHz)
64QAM			
1932.5	5	4.96	4.51
1962.5	5	4.97	4.51
1992.5	5	4.95	4.48
1935.0	10	9.97	9.31
1962.5	10	9.98	9.33
1990.0	10	10.00	9.32
1937.5	15	15.01	14.09
1962.5	15	15.06	14.14
1987.5	15	15.08	14.18
1940.0	20	20.12	18.87
1962.5	20	20.10	18.92
1985.0	20	20.16	19.03
256QAM			
1932.5	5	4.98	4.49
1962.5	5	4.96	4.50
1992.5	5	4.98	4.48
1935.0	10	10.00	9.29
1962.5	10	9.99	9.31
1990.0	10	9.97	9.32
1937.5	15	14.95	14.08
1962.5	15	15.03	14.13
1987.5	15	15.03	14.15
1940.0	20	20.14	18.88
1962.5	20	20.13	18.93
1985.0	20	20.23	19.03

5MHz Channel Bandwidth - QPSK

Bottom Channel

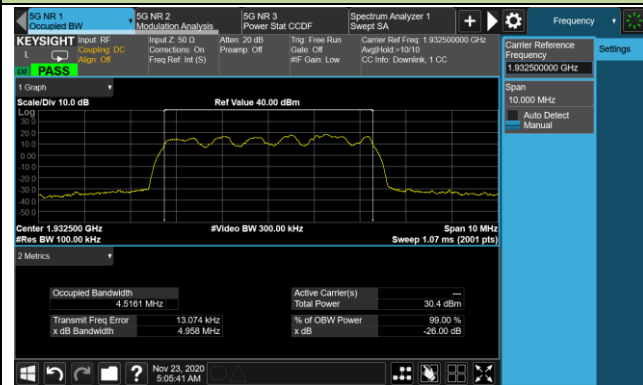

Middle Channel

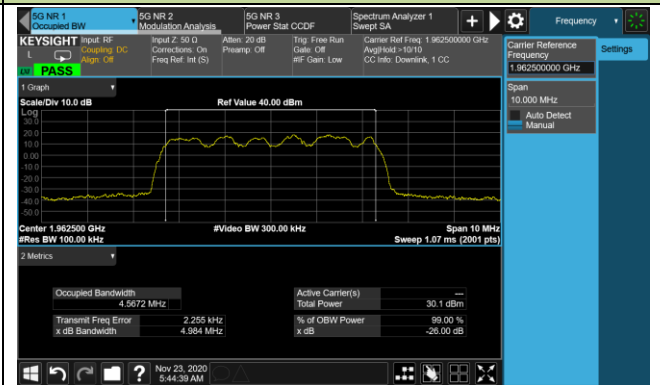

Top Channel

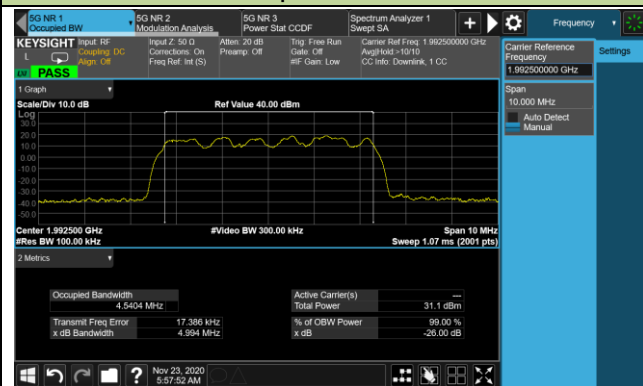

5MHz Channel Bandwidth - 16QAM

Bottom Channel

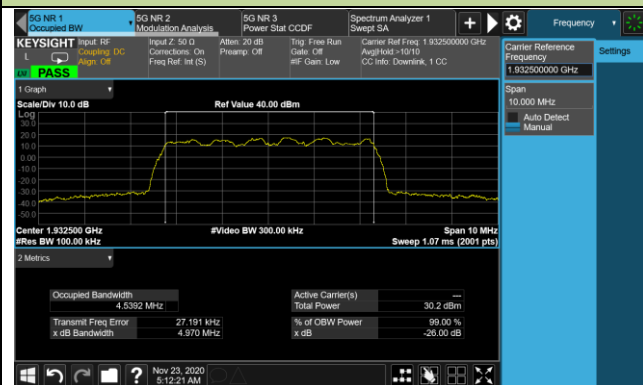

Middle Channel

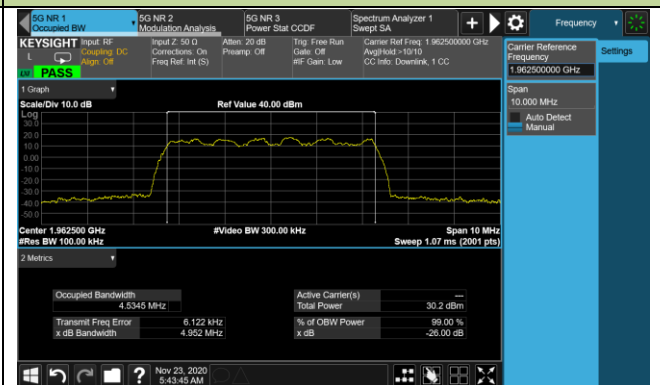

Top Channel

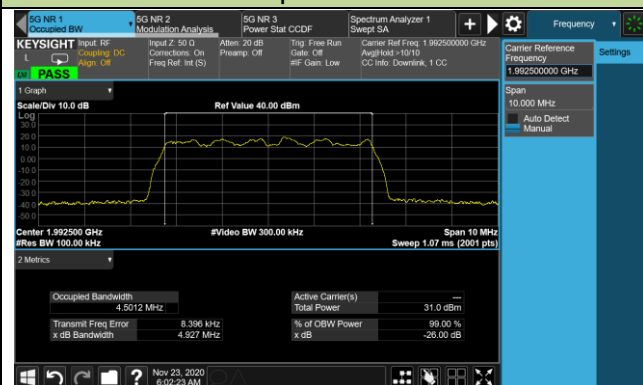

5MHz Channel Bandwidth - 64QAM

Bottom Channel

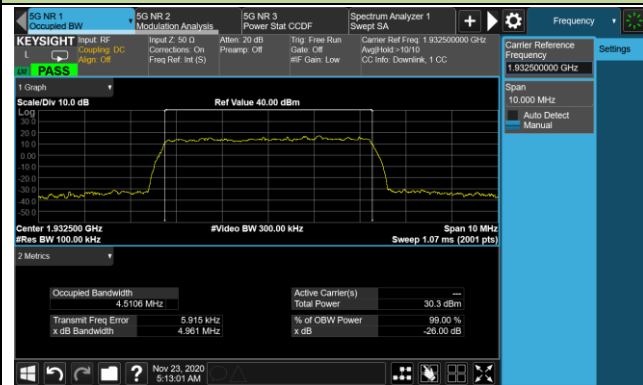

Middle Channel

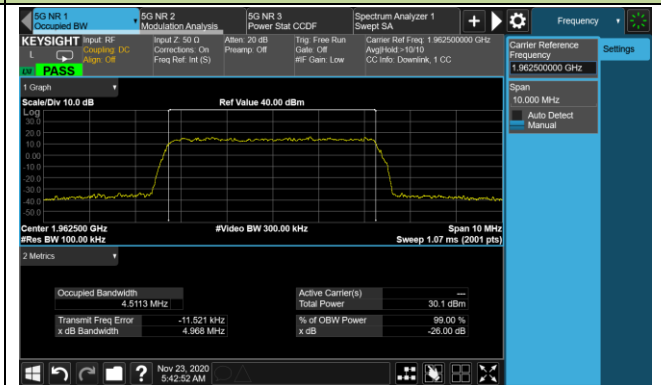

Top Channel

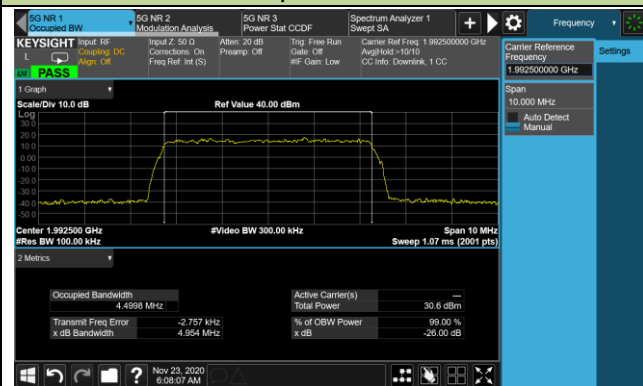

5MHz Channel Bandwidth - 256QAM

Bottom Channel

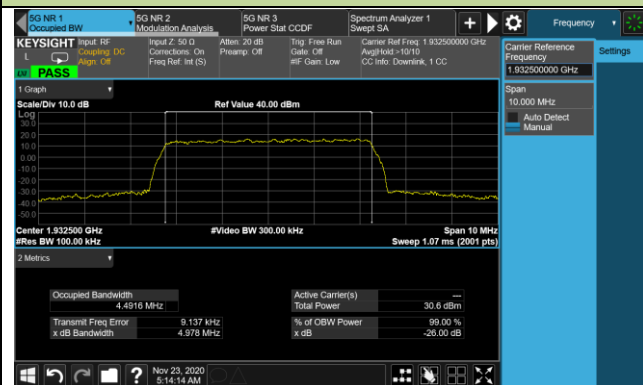

Middle Channel



Top Channel

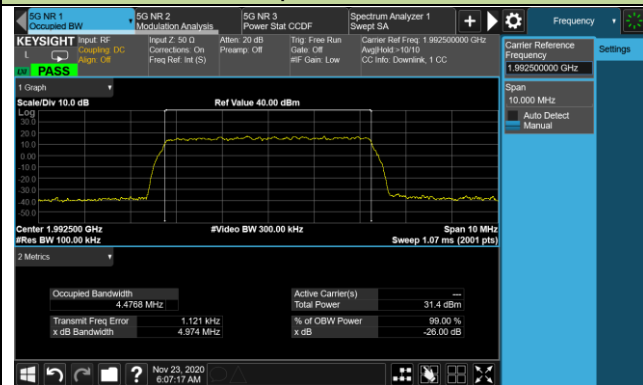

10MHz Channel Bandwidth - QPSK

Bottom Channel

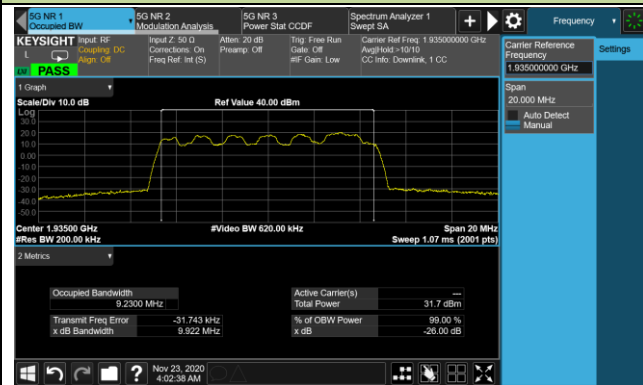

Middle Channel

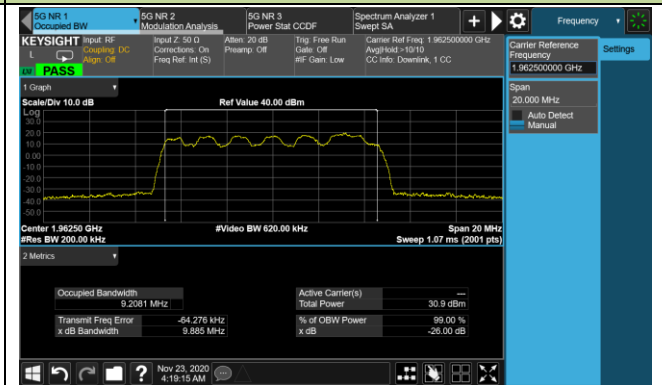

Top Channel

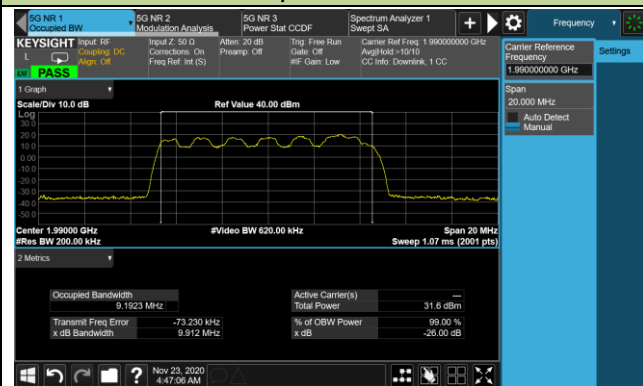

10MHz Channel Bandwidth - 16QAM

Bottom Channel

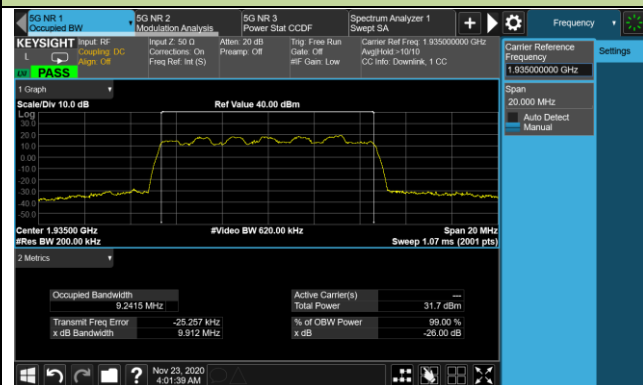

Middle Channel

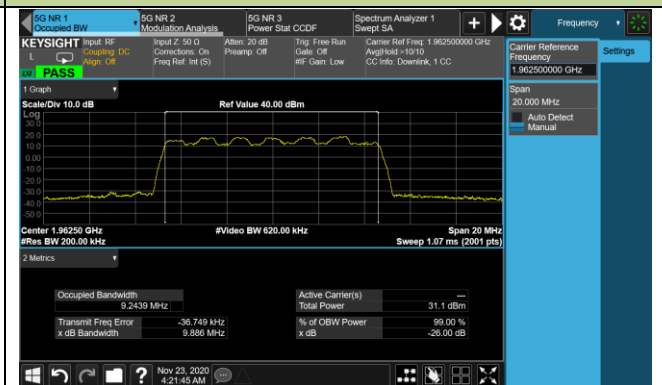

Top Channel

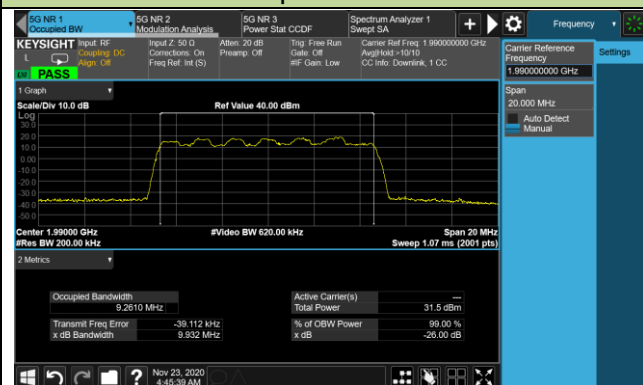

10MHz Channel Bandwidth - 64QAM

Bottom Channel

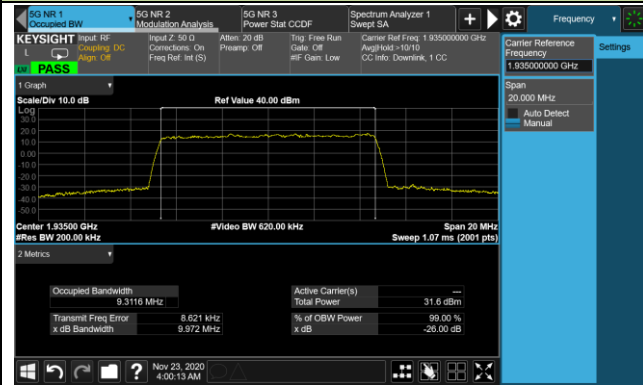

Middle Channel

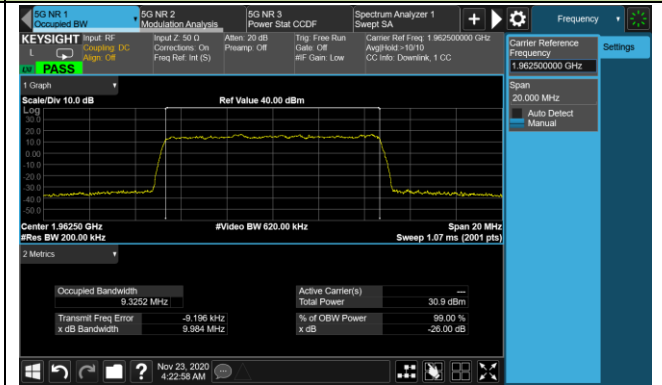

Top Channel

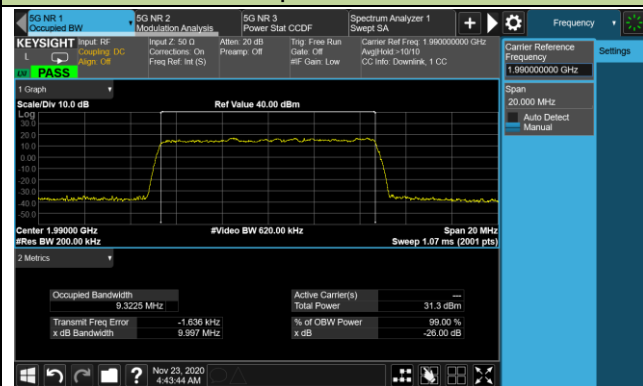

10MHz Channel Bandwidth - 256QAM

Bottom Channel

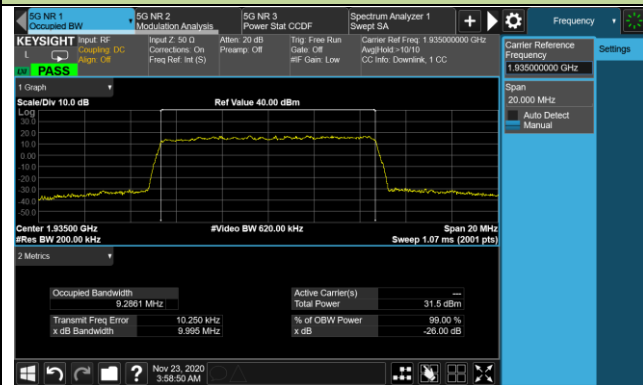

Middle Channel

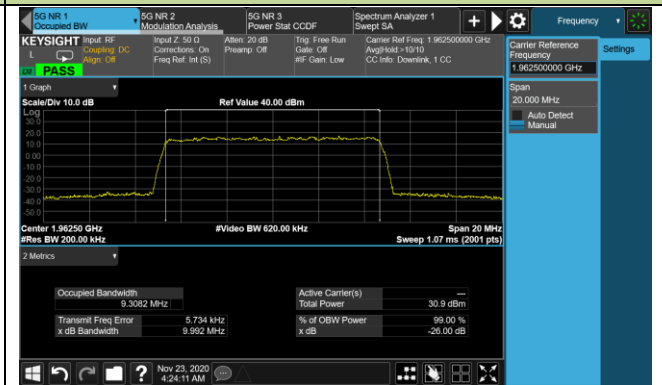

Top Channel

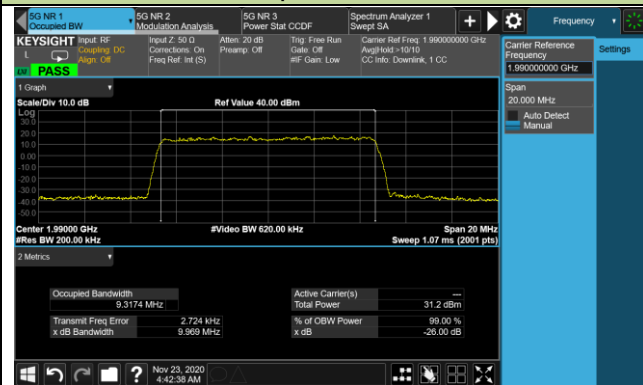

15MHz Channel Bandwidth - QPSK

Bottom Channel

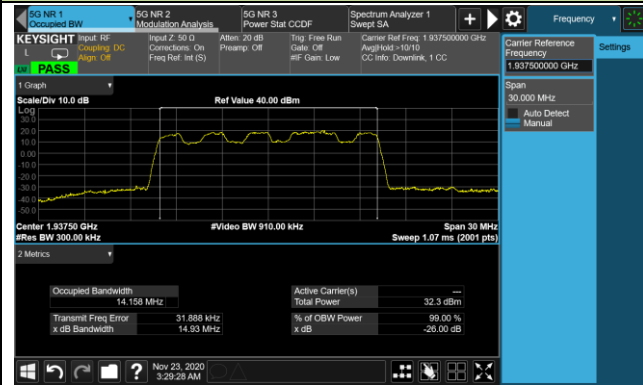

Middle Channel

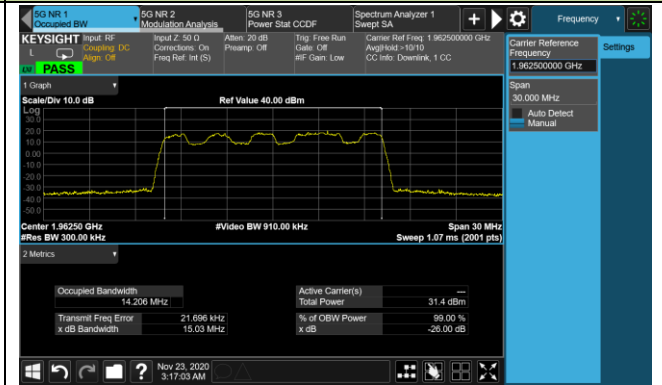

Top Channel

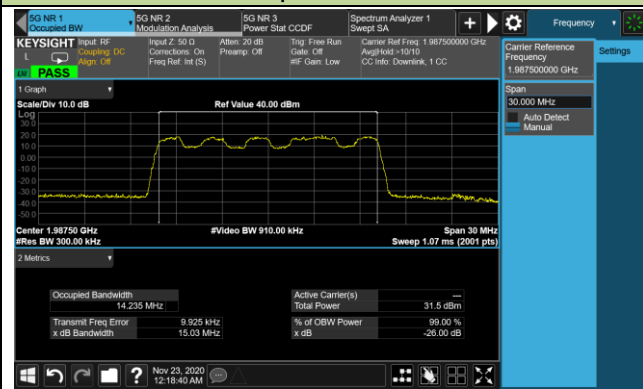

15MHz Channel Bandwidth - 16QAM

Bottom Channel

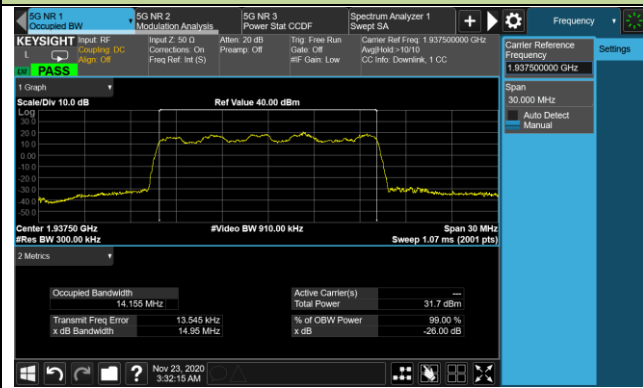

Middle Channel

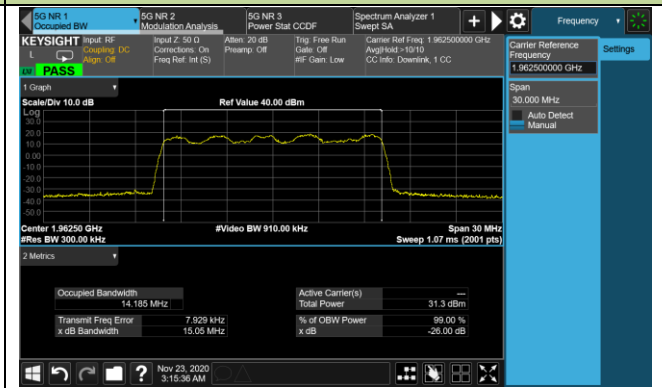

Top Channel

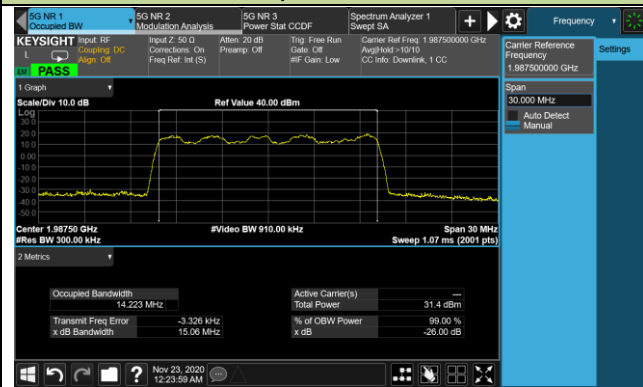

15MHz Channel Bandwidth - 64QAM

Bottom Channel

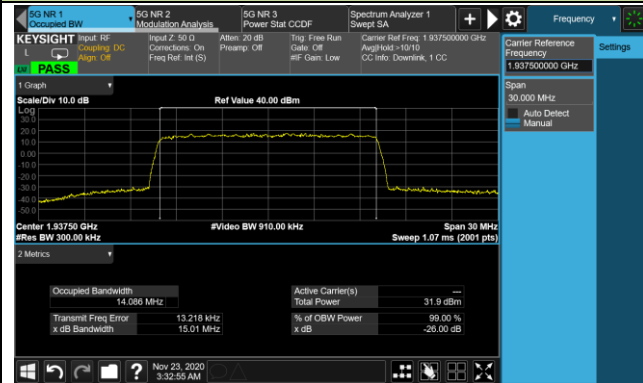

Middle Channel

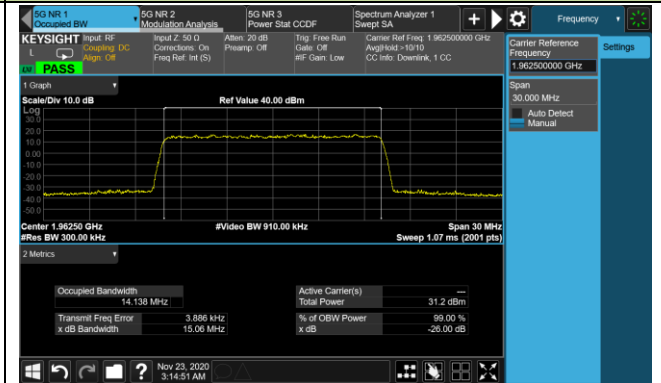

Top Channel

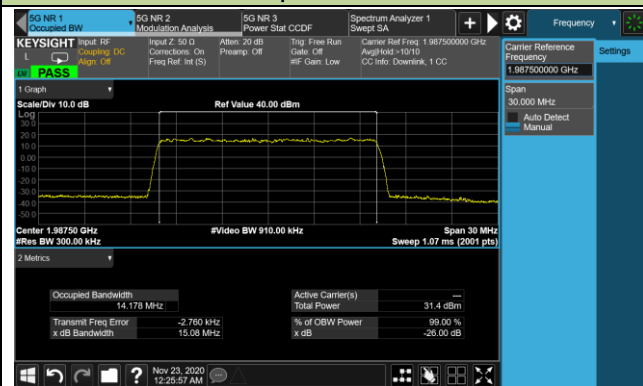

15MHz Channel Bandwidth - 256QAM

Bottom Channel

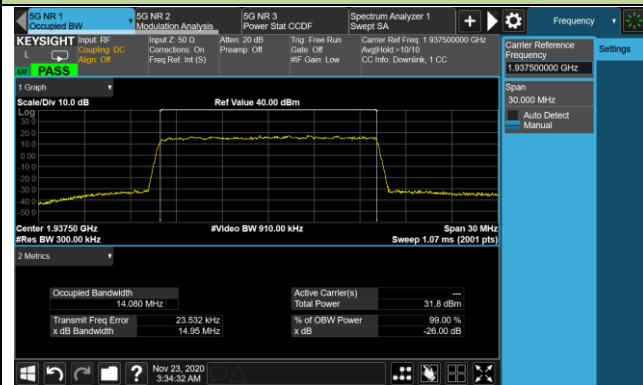

Middle Channel

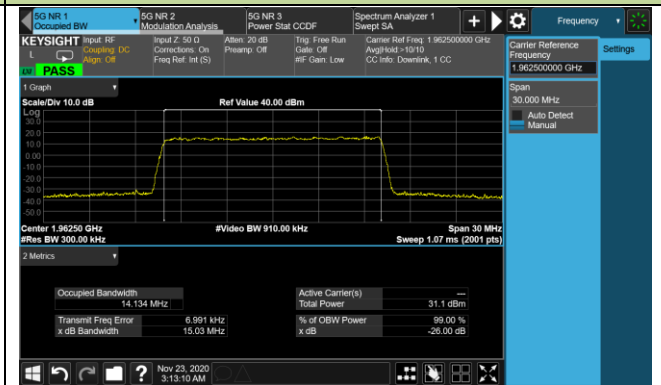

Top Channel

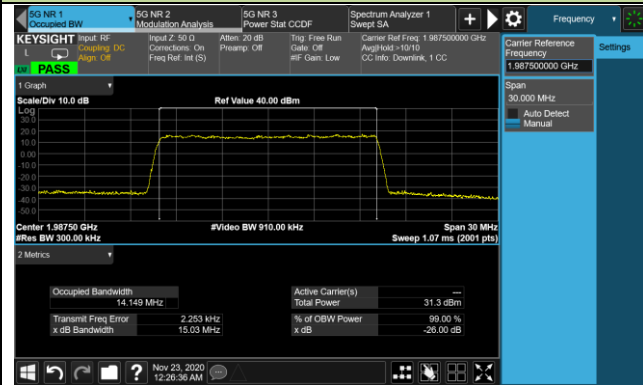

20MHz Channel Bandwidth - QPSK

Bottom Channel

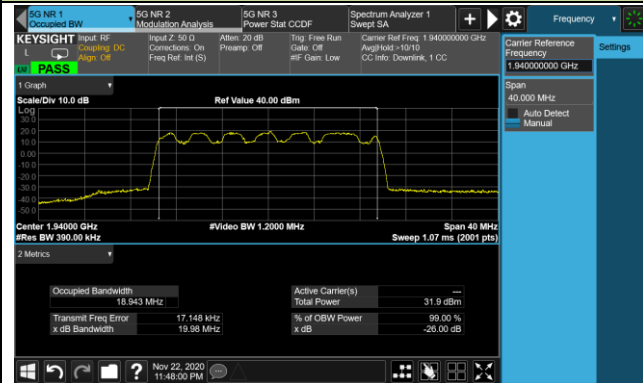

Middle Channel

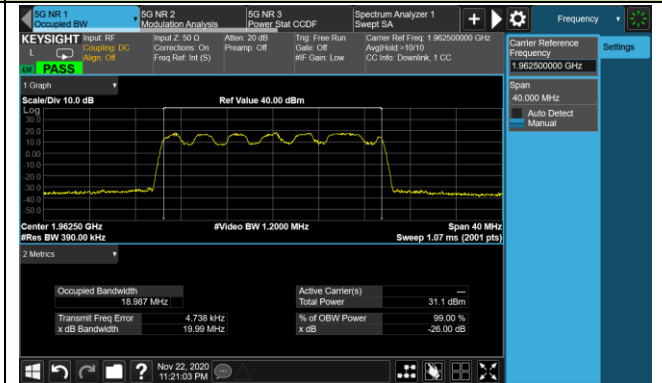

Top Channel

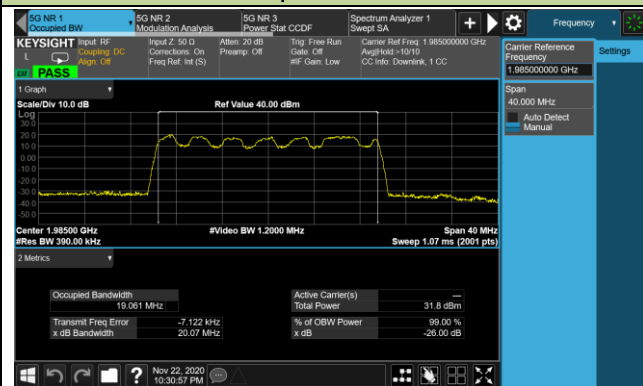

20MHz Channel Bandwidth - 16QAM

Bottom Channel

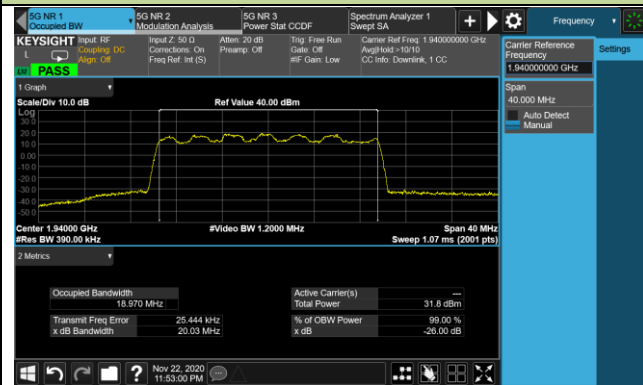

Middle Channel

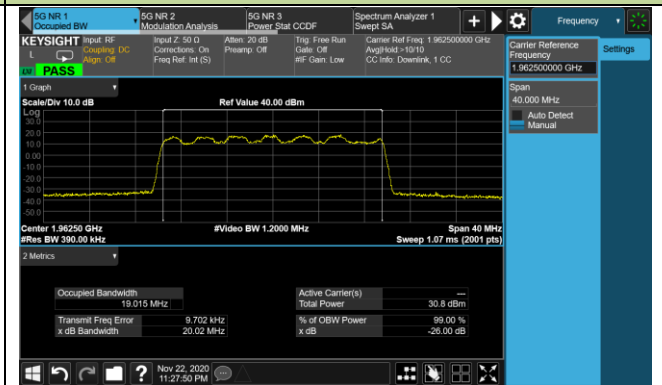

Top Channel

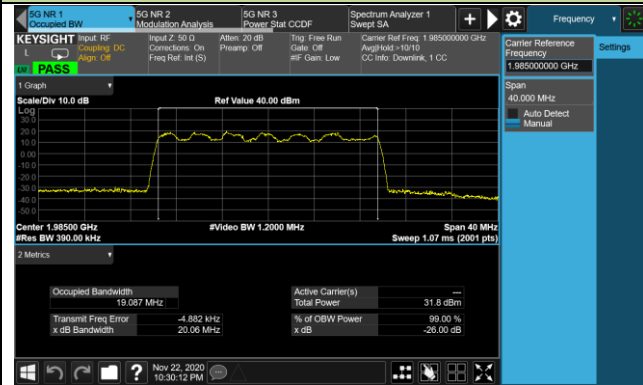

20MHz Channel Bandwidth - 64QAM

Bottom Channel

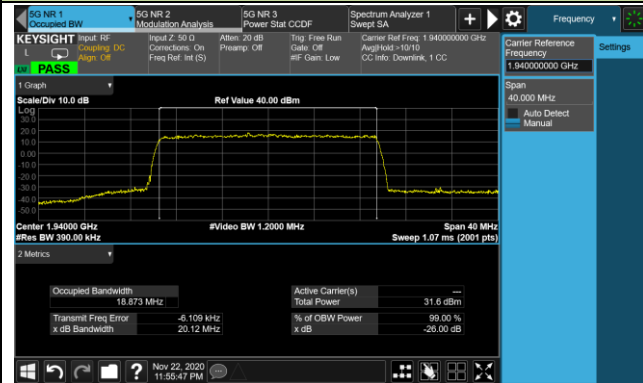

Middle Channel

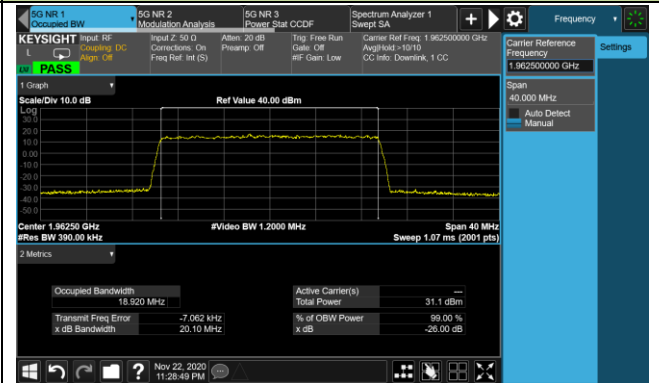

Top Channel

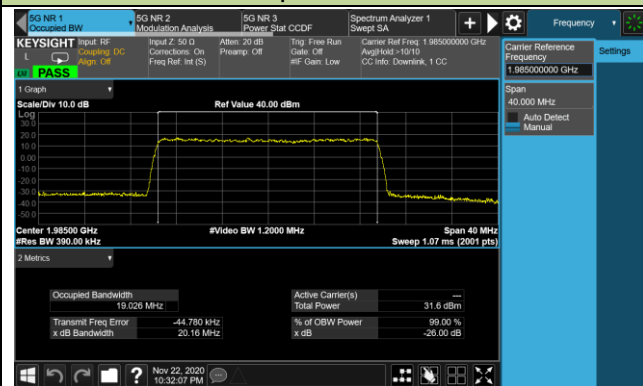

20MHz Channel Bandwidth - 256QAM

Bottom Channel

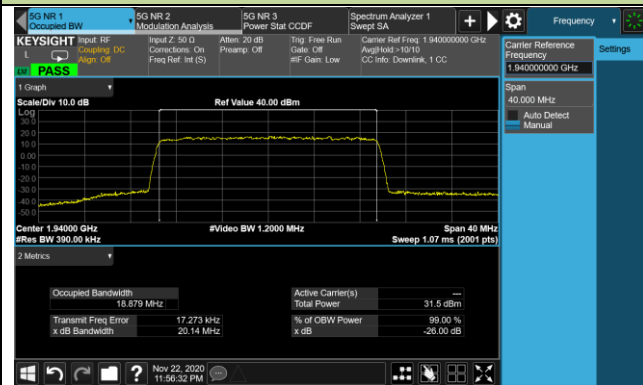

Middle Channel



Top Channel

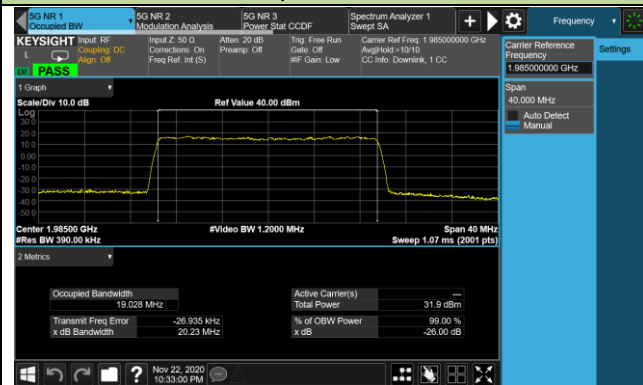

Product	AirScale Indoor Radio ASiR-pRRH	Test Engineer	Peter Xu
Test Site	SR2	Test Date	2020/11/17 ~ 2020/11/18
Test Configuration	n66 (Single Carrier)		

Frequency (MHz)	Bandwidth (MHz)	26dB Bandwidth (MHz)	99% Bandwidth (MHz)
QPSK			
2112.5	5	5.00	4.57
2145.0	5	5.00	4.57
2177.5	5	4.97	4.55
2115.0	10	9.96	9.20
2145.0	10	9.89	9.17
2175.0	10	9.93	9.20
2117.5	15	15.11	14.22
2145.0	15	14.99	14.20
2172.5	15	15.02	14.22
2120.0	20	20.09	19.02
2145.0	20	20.06	19.00
2170.0	20	20.03	19.02
16QAM			
2112.5	5	4.94	4.54
2145.0	5	4.97	4.55
2177.5	5	4.98	4.56
2115.0	10	9.95	9.25
2145.0	10	9.91	9.25
2175.0	10	9.93	9.24
2117.5	15	15.05	14.21
2145.0	15	15.01	14.20
2172.5	15	15.02	14.21
2120.0	20	20.05	19.03
2145.0	20	20.06	19.02
2170.0	20	19.97	19.03

Frequency (MHz)	Bandwidth (MHz)	26dB Bandwidth (MHz)	99% Bandwidth (MHz)
64QAM			
2112.5	5	4.99	4.52
2145.0	5	4.98	4.52
2177.5	5	4.96	4.50
2115.0	10	9.99	9.33
2145.0	10	9.97	9.33
2175.0	10	9.99	9.33
2117.5	15	15.07	14.15
2145.0	15	15.00	14.13
2172.5	15	15.07	14.15
2120.0	20	20.09	18.92
2145.0	20	20.09	18.93
2170.0	20	20.15	18.95
256QAM			
2112.5	5	4.98	4.50
2145.0	5	4.97	4.50
2177.5	5	4.97	4.50
2115.0	10	10.01	9.32
2145.0	10	10.00	9.29
2175.0	10	10.00	9.28
2117.5	15	15.04	14.15
2145.0	15	14.95	14.12
2172.5	15	15.03	14.15
2120.0	20	20.21	18.97
2145.0	20	20.14	18.93
2170.0	20	20.06	18.97

5MHz Channel Bandwidth - QPSK

Bottom Channel

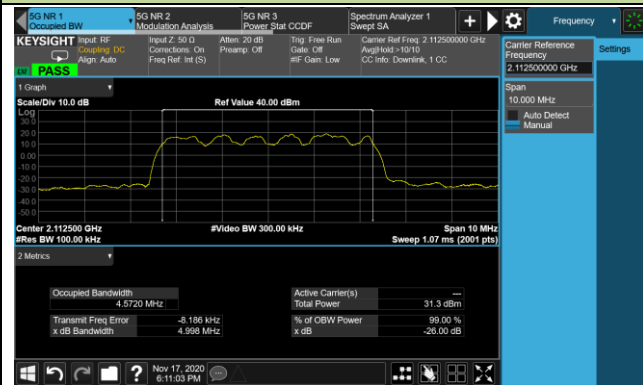

Middle Channel

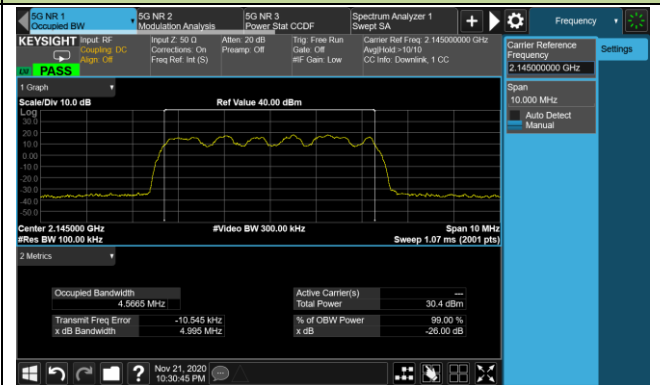

Top Channel

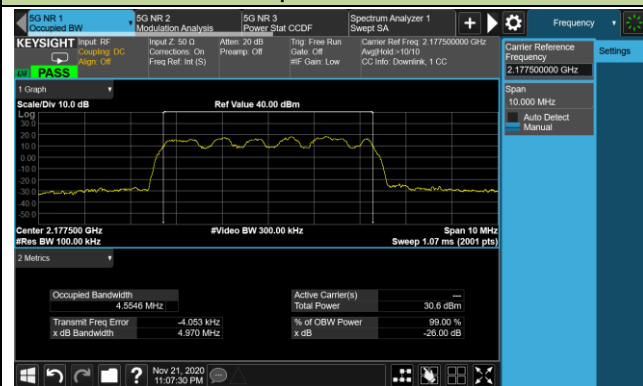

5MHz Channel Bandwidth - 16QAM

Bottom Channel

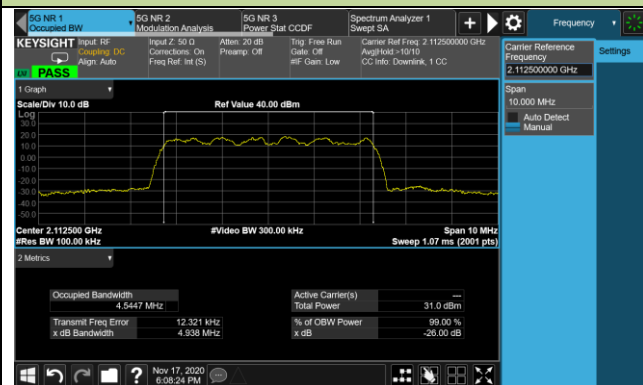

Middle Channel

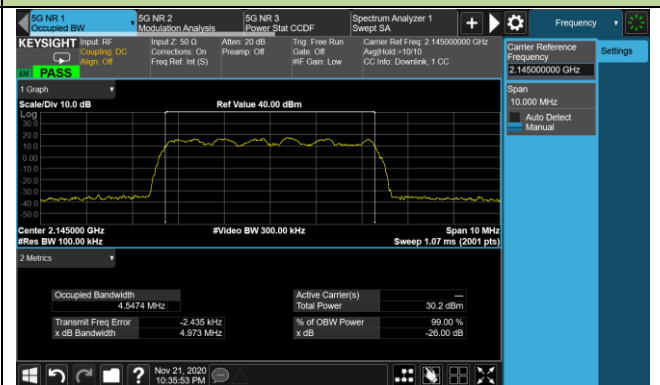

Top Channel

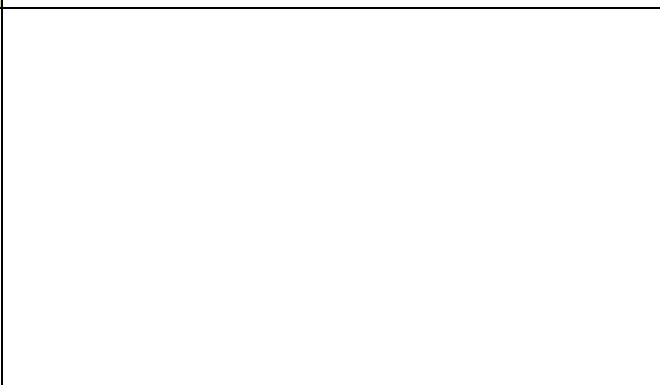
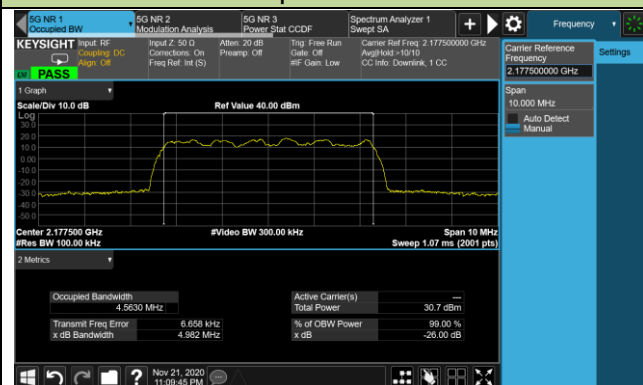

5MHz Channel Bandwidth - 64QAM

Bottom Channel

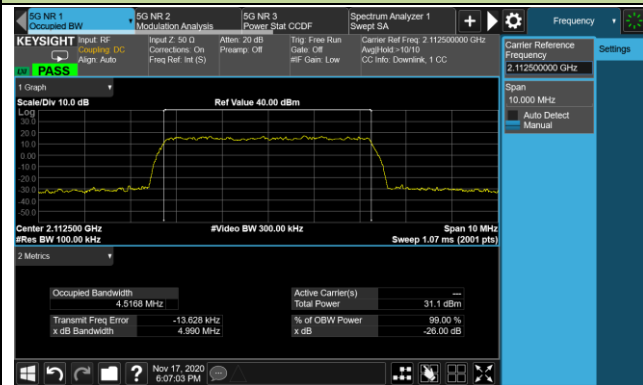

Middle Channel

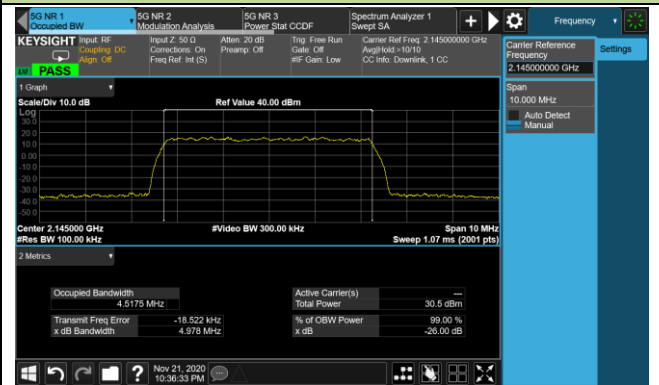

Top Channel

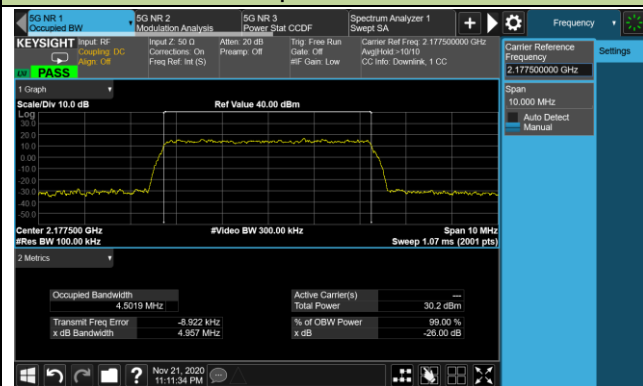

5MHz Channel Bandwidth - 256QAM

Bottom Channel

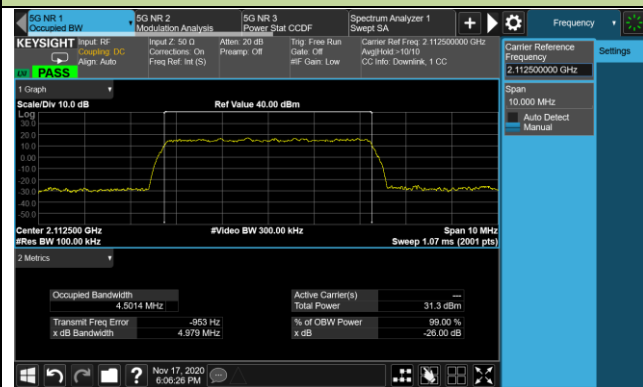

Middle Channel



Top Channel

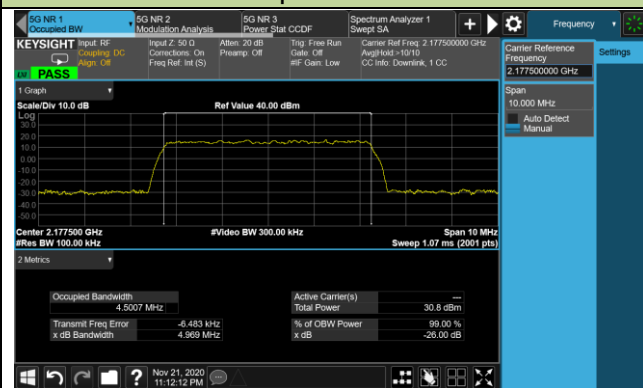

10MHz Channel Bandwidth - QPSK

Bottom Channel

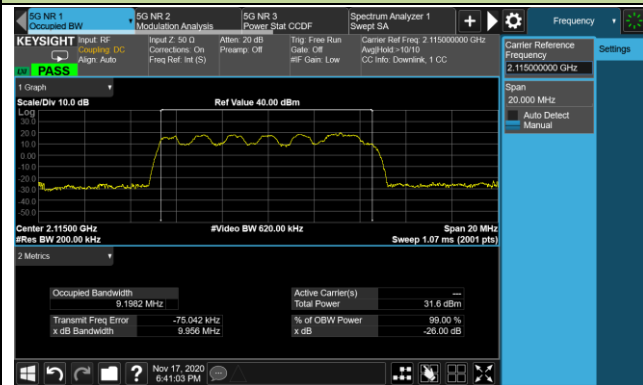

Middle Channel

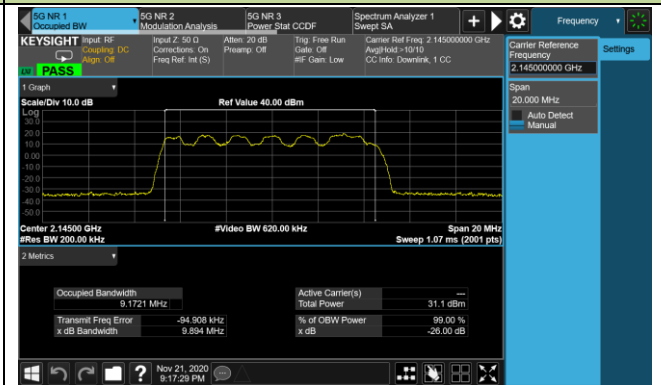

Top Channel

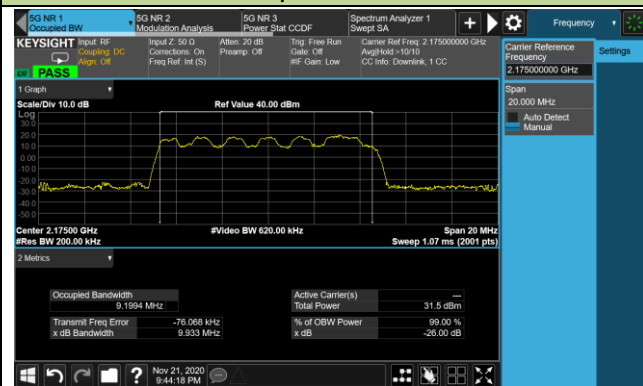

10MHz Channel Bandwidth - 16QAM

Bottom Channel

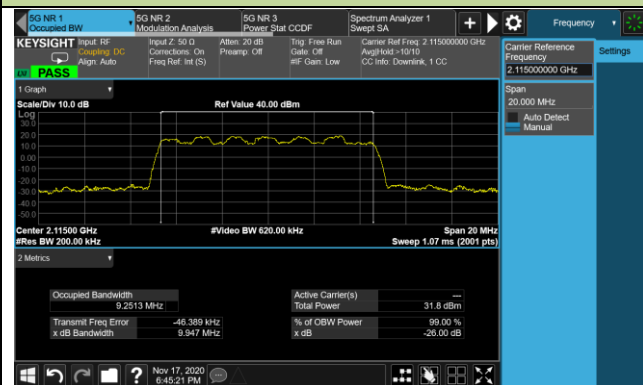

Middle Channel

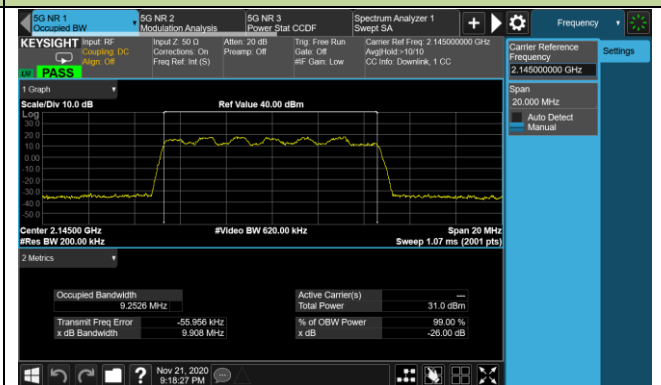

Top Channel

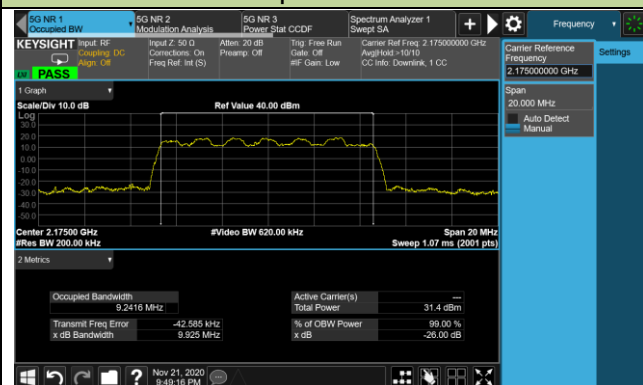

10MHz Channel Bandwidth - 64QAM

Bottom Channel

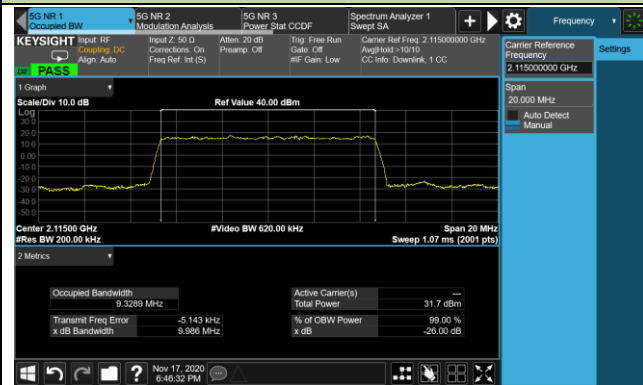

Middle Channel

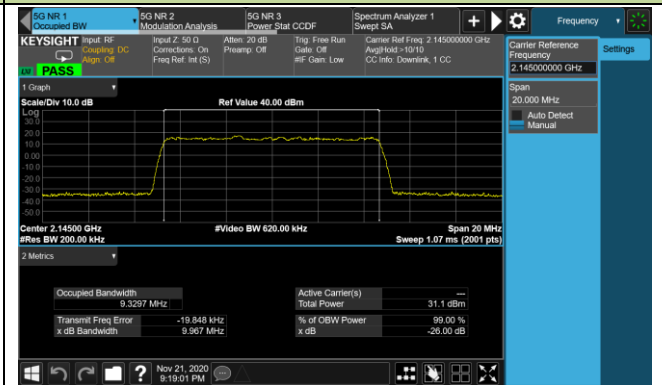

Top Channel

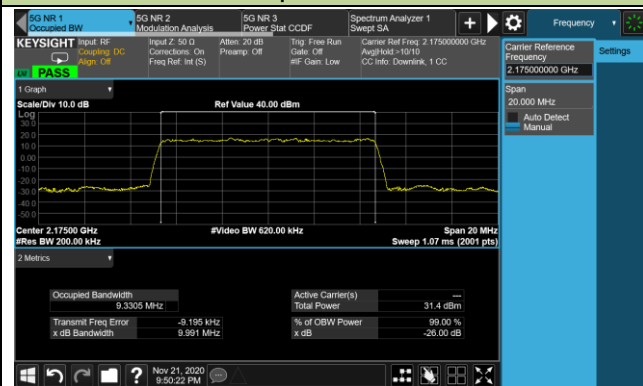

10MHz Channel Bandwidth - 256QAM

Bottom Channel

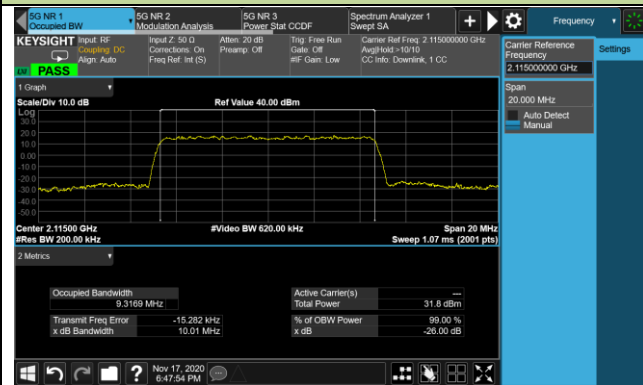

Middle Channel

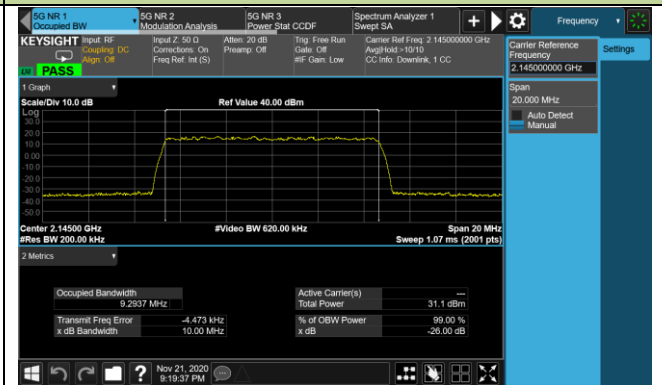

Top Channel

