

FCC Test Report (Part 27_C2PC (Class II Permissive Change))

Report No.: RF180829C14A

FCC ID: 2AD8UAHBB01

Test Model: AHBB

Received Date: Jan. 30, 2019

Test Date: Mar. 04 ~ Mar. 05, 2019, Apr. 25 ~ May 03, 2019 and Jul. 24 ~ Jul. 25, 2019

Issued Date: Jul. 31, 2019

Applicant: Nokia Solutions and Networks, OY

Address: 2000 W. Lucent Lane, Naperville, IL 60563, USA

Issued By: Bureau Veritas Consumer Products Services (H.K.) Ltd., Taoyuan Branch

Lab Address: No. 47-2, 14th Ling, Chia Pau Vil., Lin Kou Dist., New Taipei City, Taiwan (R.O.C.)

Test Location: No. 19, Hwa Ya 2nd Rd., Wen Hwa Vil., Kwei Shan Dist., Taoyuan City 33383, TAIWAN (R.O.C.)

**FCC Registration /
Designation Number:** 788550 / TW0003



This report is for your exclusive use. Any copying or replication of this report to or for any other person or entity, or use of our name or trademark, is permitted only with our prior written permission. This report sets forth our findings solely with respect to the test samples identified herein. The results set forth in this report are not indicative or representative of the quality or characteristics of the lot from which a test sample was taken or any similar or identical product unless specifically and expressly noted. Our report includes all of the tests requested by you and the results thereof based upon the information that you provided to us. You have 60 days from date of issuance of this report to notify us of any material error or omission caused by our negligence, provided, however, that such notice shall be in writing and shall specifically address the issue you wish to raise. A failure to raise such issue within the prescribed time shall constitute your unqualified acceptance of the completeness of this report, the tests conducted and the correctness of the report contents. Unless specific mention, the uncertainty of measurement has been explicitly taken into account to declare the compliance or non-compliance to the specification. The report must not be used by the client to claim product certification, approval, or endorsement by TAF or any government agency

Table of Contents

Release Control Record	4
1 Certificate of Conformity	5
2 Summary of Test Results	6
2.1 Measurement Uncertainty.....	6
2.2 Test Site and Instruments.....	7
3 General Information	8
3.1 General Description of EUT.....	8
3.2 Configuration of System under Test.....	10
3.2.1 Description of Support Units.....	10
3.3 Test Mode Applicability and Tested Channel Detail.....	11
3.4 EUT Operating Conditions.....	13
3.5 General Description of Applied Standards.....	13
4 Test Types and Results	14
4.1 Output Power Measurement.....	14
4.1.1 Limits of Output Power Measurement.....	14
4.1.2 Test Procedures.....	14
4.1.3 Test Setup.....	14
4.1.4 Test Results.....	15
4.2 Modulation Characteristics Measurement.....	21
4.2.1 Limits of Modulation Characteristics.....	21
4.2.2 Test Procedure.....	21
4.2.3 Test Setup.....	21
4.2.4 Test Results.....	22
4.3 Frequency Stability Measurement.....	23
4.3.1 Limits of Frequency Stability Measurement.....	23
4.3.2 Test Procedure.....	23
4.3.3 Test Setup.....	23
4.3.4 Test Results.....	24
4.4 Emission Bandwidth Measurement.....	26
4.4.1 Limits of Emission Bandwidth Measurement.....	26
4.4.2 Test Procedure.....	26
4.4.3 Test Setup.....	26
4.4.4 Test Result.....	27
4.5 Band Edge Measurement.....	30
4.5.1 Limits of Band Edge Measurement.....	30
4.5.2 Test Setup.....	30
4.5.3 Test Procedures.....	30
4.5.4 Test Results.....	31
4.6 Peak to Average Ratio.....	43
4.6.1 Limits of Peak to Average Ratio Measurement.....	43
4.6.2 Test Setup.....	43
4.6.3 Test Procedures.....	43
4.6.4 Test Results.....	44
4.7 Conducted Spurious Emissions.....	46
4.7.1 Limits of Conducted Spurious Emissions Measurement.....	46
4.7.2 Test Setup.....	46
4.7.3 Test Procedure.....	46
4.7.4 Test Results.....	47
4.8 Radiated Emission Measurement.....	127
4.8.1 Limits of Radiated Emission Measurement.....	127
4.8.2 Test Procedure.....	127
4.8.3 Deviation from Test Standard.....	127
4.8.4 Test Setup.....	128

4.8.5 Test Results	129
5 Pictures of Test Arrangements.....	140
Appendix – Information of the Testing Laboratories	141

Release Control Record

Issue No.	Description	Date Issued
RF180829C14A	Original release	Jul. 31, 2019

1 Certificate of Conformity

Product: AirScale Micro Remote Radio Head

Brand: Nokia

Test Model: AHBB

Sample Status: Engineering sample

Applicant: Nokia Solutions and Networks, OY

Test Date: Mar. 04 ~ Mar. 05, 2019, Apr. 25 ~ May 03, 2019 and Jul. 24 ~ Jul. 25, 2019

Standards: FCC Part 27, Subpart C, F
FCC Part 2, Subpart J

The above equipment has been tested by **Bureau Veritas Consumer Products Services (H.K.) Ltd., Taoyuan Branch**, and found compliance with the requirement of the above standards. The test record, data evaluation & Equipment Under Test (EUT) configurations represented herein are true and accurate accounts of the measurements of the sample's RF characteristics under the conditions specified in this report.

Prepared by : Celine Chou , **Date:** Jul. 31, 2019
Celine Chou / Senior Specialist

Approved by : Bruce Chen , **Date:** Jul. 31, 2019
Bruce Chen / Project Engineer

2 Summary of Test Results

Applied Standard: FCC Part 27 & Part 2			
FCC Clause	Test Item	Result	Remarks
2.1046 27.50(b)(5)	Equivalent Isotropically Radiated Power	Pass	Meet the requirement of limit.
----	Peak To Average Ratio	Pass	Meet the requirement of limit.
2.1055 27.54	Frequency Stability Stay with the authorized bands of operation	Pass	Meet the requirement of limit.
2.1049	Emission Bandwidth	Pass	Meet the requirement of limit.
2.1051 27.53(c)	Band Edge Measurements	Pass	Meet the requirement of limit.
2.1051 27.53(c)	Conducted Spurious Emissions	Pass	Meet the requirement of limit.
2.1051 27.53(c)	Radiated Spurious Emissions	Pass	Meet the requirement of limit. Minimum passing margin is -36.30dB at 33.88MHz.

Note: Determining compliance based on the results of the compliance measurement, not taking into account measurement instrumentation uncertainty.

2.1 Measurement Uncertainty

Where relevant, the following measurement uncertainty levels have been estimated for tests performed on the EUT as specified in CISPR 16-4-2:

Measurement	Frequency	Expanded Uncertainty (k=2) (±)
Radiated Emissions up to 1 GHz	30MHz ~ 200MHz	3.59 dB
	200MHz ~1000MHz	3.60 dB
Radiated Emissions above 1 GHz	1GHz ~ 18GHz	2.29 dB
	18GHz ~ 40GHz	2.29 dB

2.2 Test Site and Instruments

Description & Manufacturer	Model No.	Serial No.	Cal. Date	Cal. Due
Test Receiver KEYSIGHT	N9038A	MY55420137	Apr. 11, 2018	Apr. 10, 2019
			Apr. 15, 2019	Apr. 14, 2020
Spectrum Analyzer ROHDE & SCHWARZ	FSP40	100269	May 29, 2018	May 28, 2019
			Jun. 04, 2019	Jun. 03, 2020
BILOG Antenna SCHWARZBECK	VULB9168	9168-160	Nov. 21, 2018	Nov. 20, 2019
HORN Antenna SCHWARZBECK	BBHA 9120 D	9120D-1169	Nov. 25, 2018	Nov. 24, 2019
HORN Antenna SCHWARZBECK	BBHA 9170	BBHA9170241	Nov. 25, 2018	Nov. 24, 2019
Loop Antenna TESEQ	HLA 6121	45745	Jun. 14, 2018	Jun. 13, 2019
			Jul. 01, 2019	Jun. 30, 2020
Preamplifier Agilent (Below 1GHz)	8447D	2944A10638	Aug. 08, 2018	Aug. 07, 2019
Preamplifier Agilent (Above 1GHz)	8449B	3008A01924	Feb. 22, 2018	Feb. 21, 2019
			Feb. 21, 2019	Feb. 20, 2020
RF signal cable HUBER+SUHNER&EMCI	SUCOFLEX 104 & EMC104-SM-SM8000	CABLE-CH9-02 (248780+171006)	Jan. 19, 2019	Jan. 18, 2020
RF signal cable HUBER+SUHNER	SUCOFLEX 104	CABLE-CH9-(250795/4)	Aug. 08, 2018	Aug. 07, 2019
RF signal cable Woken	8D-FB	Cable-CH9-01	Jul. 31, 2018	Jul. 30, 2019
Software BV ADT	ADT_Radiated_ V7.6.15.9.5	NA	NA	NA
Antenna Tower EMCO	2070/2080	512.835.4684	NA	NA
Turn Table EMCO	2087-2.03	NA	NA	NA
Antenna Tower & Turn BV ADT	AT100	AT93021705	NA	NA
Turn Table BV ADT	TT100	TT93021705	NA	NA
Turn Table Controller BV ADT	SC100	SC93021705	NA	NA
Boresight Antenna Fixture	FBA-01	FBA-SIP01	NA	NA
JFW 20dB attenuation	50HF-020-SMA	NA	NA	NA
Radio Communication Analyzer	MT8821C	6261786083	Dec. 11, 2018	Dec. 10, 2019
WIT Standard Temperature And Humidity Chamber	TH-4S-C	W981030	Jun. 04, 2018	Jun. 03, 2019
			Jun. 03, 2019	Jun. 02, 2020

Note: 1. The calibration interval of the above test instruments is 12 months and the calibrations are traceable to NML/ROC and NIST/USA.
 2. The test was performed in HwaYa Chamber 9.

3 General Information

3.1 General Description of EUT

Product	AirScale Micro Remote Radio Head		
Brand	Nokia		
Test Model	AHBB		
Status of EUT	Engineering sample		
Power Supply Rating	I/P: 100-240Vac, 50-60Hz, 3A MAX O/P: -54Vdc, 3A MAX		
Modulation Type	LTE Band 13 NB-IOT Guard Band	QPSK	
	LTE Band 13 NB-IOT In-Band	QPSK	
Operating Frequency	LTE Band 13 NB-IOT Guard Band	Channel Bandwidth 10MHz	751.0MHz
	LTE Band 13 NB-IOT In-Band	Channel Bandwidth 5MHz	748.5MHz ~ 753.5MHz
		Channel Bandwidth 10MHz	751.0MHz
Max. ERP Power	LTE Band 13 NB-IOT Guard Band	Channel Bandwidth 10MHz	87498.378mW (49.42dBm)
	LTE Band 13 NB-IOT In-Band	Channel Bandwidth 5MHz	92682.982mW (49.67dBm)
		Channel Bandwidth 10MHz	100000mW (50dBm)
Emission Designator	LTE Band 13 NB-IOT Guard Band	Channel Bandwidth 10MHz	9M20G7D
	LTE Band 13 NB-IOT In-Band	Channel Bandwidth 5MHz	4M49G7D
		Channel Bandwidth 10MHz	8M93G7D
Antenna Gain	8dBi		
S/N	474042A		
HW Version	X21		
SW Version	FDD-LTE 18A		
Accessory Device	Refer to Note as below		
Cable Supplied	NA		

Note:

- This report is prepared for FCC class II permissive change. This is a supplementary report of Report No.: RF180829C14. The differences between them are as below information:
 - ◆ LTE B13 add NB-IOT Guard Band
 - ◆ LTE B13 add NB-IOT In-band
- For above changes, only NB-IOT Guard Band mode and NB-IOT In-band mode test results has to be performed. The other test items were copied from the original test report (Report No.: RF180829C14) and all data was verified to meet the requirements.
- The EUT incorporates a MIMO function. Physically, the EUT provides 4 completed transmitters and 4 receivers.

Modulation Mode	TX Function
N-TM (QPSK)	1TX
N-TM (QPSK)	2TX
N-TM (QPSK)	3TX
N-TM (QPSK)	4TX

4. The EUT contains following accessory devices.

AC PSU (Optional)	
Brand	Nokia
Model	APAB
Sales Item	474130A.102
S/N	U7174800066
Remark	SUPLET/S818A160-220S54W
Input Power	100-240Vac, 50-60Hz, 3A MAX
Output Power	-54Vdc, 3A MAX

5. The antenna gain for reference only, the test was done with 50ohm terminator on antenna port.

3.2 Configuration of System under Test

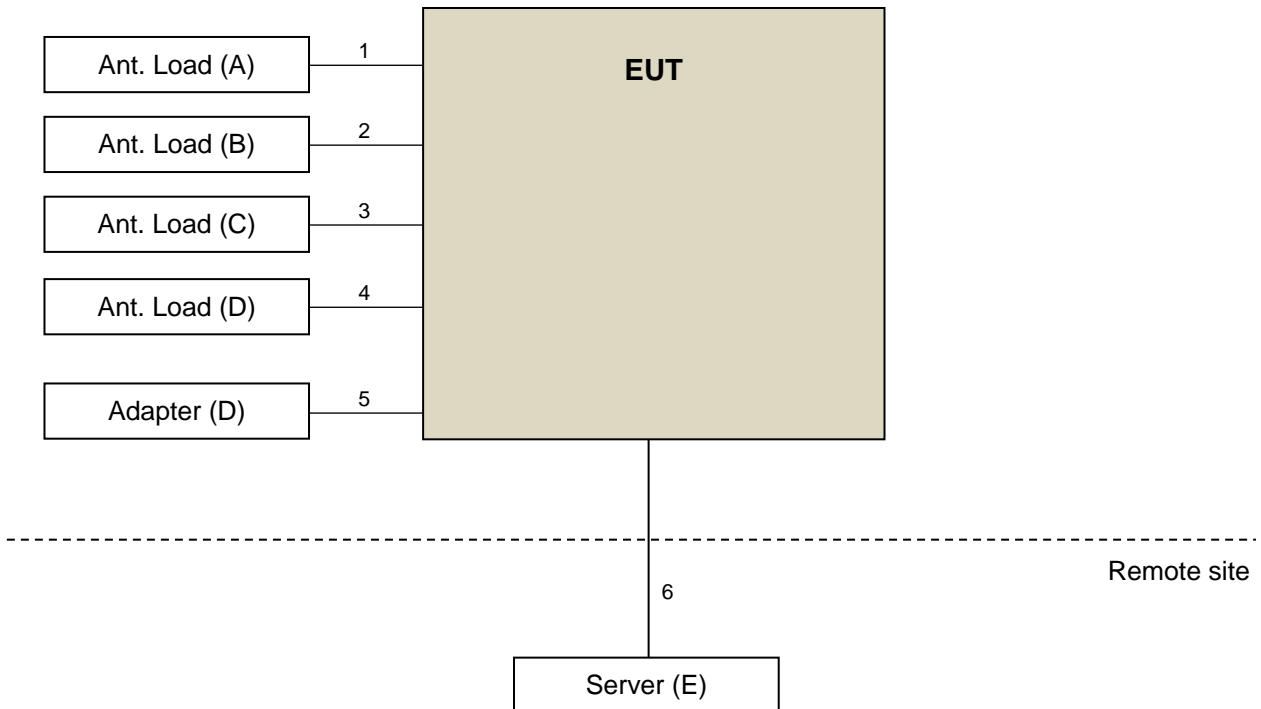

3.2.1 Description of Support Units

The EUT has been tested as an independent unit together with other necessary accessories or support units. The following support units or accessories were used to form a representative test configuration during the tests.

ID	Product	Brand	Model No.	Serial No.	FCC ID	Remarks
A.	Ant. Load	NA	NA	NA	NA	Provided by manufacturer
B.	Ant. Load	NA	NA	NA	NA	Provided by manufacturer
C.	Ant. Load	NA	NA	NA	NA	Provided by manufacturer
D.	Ant. Load	NA	NA	NA	NA	Provided by manufacturer
E.	Adapter	NA	NA	NA	NA	Provided by manufacturer
F.	Server	NA	NA	NA	NA	Provided by manufacturer

Note:

1. All power cords of the above support units are non-shielded (1.8m).
2. Item E acted as a communication partner to transfer data.

ID	Descriptions	Qty.	Length (m)	Shielding (Yes/No)	Cores (Qty.)	Remarks
1.	Ant. Cable	1	1	Y	0	-
2.	Ant. Cable	1	1	Y	0	-
3.	Ant. Cable	1	1	Y	0	-
4.	Ant. Cable	1	1	Y	0	-
5.	DC Cable	1	0.55	N	0	Provided by manufacturer
6.	Fiber Cable	2	10	N	0	-

3.3 Test Mode Applicability and Tested Channel Detail

Pre-Scan has been conducted to determine the worst-case mode from all possible combinations between available modulations, data rates, XYZ axis and antenna ports. The worst case was found when positioned on X-plane. Following channel(s) was (were) selected for the final test as listed below:

NB-IOT Guard Band

EUT Configure Mode	Test item	Channel	Center Carrier Frequency of E-UTRA channel	Bottom Freq.	Top Freq.	Channel Bandwidth	Modulation	Mode
-	ERP	5230	751.0MHz	746.4025MHz	755.5975MHz	10MHz	QPSK	1RB
-	Modulation Characteristics	5230	751.0MHz	746.4025MHz	755.5975MHz	10MHz	QPSK	1RB
-	Frequency Stability	5230	751.0MHz	746.4025MHz	755.5975MHz	10MHz	QPSK	1RB
-	Emission Bandwidth	5230	751.0MHz	746.4025MHz	755.5975MHz	10MHz	QPSK	1RB
-	Band Edge	5230	751.0MHz	746.4025MHz	755.5975MHz	10MHz	QPSK	1RB
-	Peak to Average Ratio	5230	751.0MHz	746.4025MHz	755.5975MHz	10MHz	QPSK	1RB
-	Conducted Emission	5230	751.0MHz	746.4025MHz	755.5975MHz	10MHz	QPSK	1RB
-	Radiated Emission below 1GHz	5230	751.0MHz	746.4025MHz	-	10MHz	QPSK	1RB
-	Radiated Emission above 1GHz	5230	751.0MHz	746.4025MHz	755.5975MHz	10MHz	QPSK	1RB

NB-IOT In-Band

EUT Configure Mode	Test item	Channel	Center Carrier Frequency of E-UTRA channel	Bottom Freq.	Top Freq.	Channel Bandwidth	Modulation	Mode
-	ERP	5205 to 5255	748.5MHz 751.0MHz 753.5MHz	746.7MHz 753.5MHz 751.7MHz	750.3MHz 752.8MHz 755.3MHz	5MHz	QPSK	1RB
		5230	751.0MHz	747.22MHz	754.60MHz	10MHz	QPSK	1RB
-	Modulation Characteristics	5230	751.0MHz	747.22MHz	754.60MHz	10MHz	QPSK	1RB
-	Frequency Stability	5230	751.0MHz	747.22MHz	754.60MHz	10MHz	QPSK	1RB
-	Emission Bandwidth	5205 to 5255	748.5MHz 751.0MHz 753.5MHz	746.7MHz 753.5MHz 751.7MHz	750.3MHz 752.8MHz 755.3MHz	5MHz	QPSK	1RB
		5230	751.0MHz	747.22MHz	754.60MHz	10MHz	QPSK	1RB
-	Band Edge	5205 to 5255	748.5MHz 753.5MHz	746.7MHz 751.7MHz	750.3MHz 755.3MHz	5MHz	QPSK	1RB
		5230	751.0MHz	747.22MHz	754.60MHz	10MHz	QPSK	1RB
-	Peak to Average Ratio	5205 to 5255	748.5MHz 751.0MHz 753.5MHz	746.7MHz 753.5MHz 751.7MHz	750.3MHz 752.8MHz 755.3MHz	5MHz	QPSK	1RB
		5230	751.0MHz	747.22MHz	754.60MHz	10MHz	QPSK	1RB
-	Conducted Emission	5205 to 5255	748.5MHz 751.0MHz 753.5MHz	746.7MHz 753.5MHz 751.7MHz	750.3MHz 752.8MHz 755.3MHz	5MHz	QPSK	1RB
		5230	751.0MHz	747.22MHz	754.60MHz	10MHz	QPSK	1RB
-	Radiated Emission below 1GHz	5205 to 5255	751.0MHz	753.5MHz	752.8MHz	5MHz	QPSK	1RB
		5230	751.0MHz	747.22MHz	-	10MHz	QPSK	1RB
-	Radiated Emission above 1GHz	5205 to 5255	748.5MHz 751.0MHz 753.5MHz	746.7MHz 753.5MHz 751.7MHz	750.3MHz 752.8MHz 755.3MHz	5MHz	QPSK	1RB
		5230	751.0MHz	747.22MHz	754.60MHz	10MHz	QPSK	1RB

Test Condition:

Test Item	Environmental Conditions	Input Power	Tested By
ERP	24deg. C, 64%RH	120Vac, 60Hz	James Yang
Modulation characteristics	24deg. C, 64%RH	120Vac, 60Hz	James Yang
Frequency Stability	24deg. C, 64%RH	120Vac, 60Hz	James Yang
Emission Bandwidth	24deg. C, 64%RH	120Vac, 60Hz	James Yang
Band Edge	24deg. C, 64%RH	120Vac, 60Hz	James Yang
Peak To Average Ratio	24deg. C, 64%RH	120Vac, 60Hz	James Yang
Conducted Emission	24deg. C, 64%RH	120Vac, 60Hz	James Yang
Radiated Emission	23deg. C, 68%RH 22deg. C, 66%RH	120Vac, 60Hz	Han Wu Greg Lin

3.4 EUT Operating Conditions

The EUT makes a call to the communication simulator. The communication simulator station system controlled a EUT to export maximum output power under transmission mode and specific channel frequency

3.5 General Description of Applied Standards

The EUT is a RF Product. According to the specifications of the manufacturer, it must comply with the requirements of the following standards:

FCC 47 CFR Part 2

FCC 47 CFR Part 27

KDB 971168 D01 Power Meas License Digital Systems v03r01

KDB 662911 D01 Multiple Transmitter Output v02r01

ANSI/TIA/EIA-603-E 2016

ANSI 63.26-2015

Note: All test items have been performed and recorded as per the above standards.

4 Test Types and Results

4.1 Output Power Measurement

4.1.1 Limits of Output Power Measurement

Fixed and base stations located in a county with population density of 100 or fewer persons per square mile, based upon the most recently available population statistics from the Bureau of the Census, and transmitting a signal in the 746-757 MHz and 776-787 MHz bands with an emission bandwidth greater than 1 MHz must not exceed an ERP of 2000 watts/MHz and an antenna height of 305 m HAAT, except that antenna heights greater than 305 m HAAT are permitted if power levels are reduced below 2000 watts/MHz ERP in accordance with Table 4 of this section.

4.1.2 Test Procedures

The EUT was set up for the maximum power with LTE link data modulation and link up with simulator. Set the EUT to transmit under low, middle and high channel and record the power level shown on simulator.

4.1.3 Test Setup

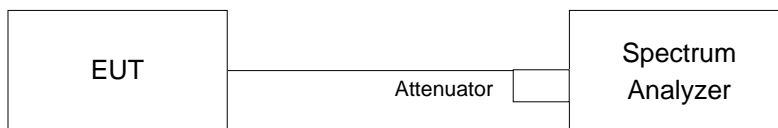

4.1.4 Test Results

NB-IOT Guard Band

Channel Bandwidth: 10MHz

Conducted Output Power (dBm)

1TX

Band / BW	Chain	QPSK_NB-IoT Signal at Bottom	QPSK_NB-IoT Signal at Top
		751 MHz	751 MHz
13 / 10M	0	37.36	37.45
	1	37.74	37.35
	2	37.63	37.48
	3	37.47	37.25

2TX

Band / BW	Chain	QPSK_NB-IoT Signal at Bottom	QPSK_NB-IoT Signal at Top
		751 MHz	751 MHz
13 / 10M	0+1	40.56	40.41
	2+3	40.56	40.38

3TX

Band / BW	Chain	QPSK_NB-IoT Signal at Bottom	QPSK_NB-IoT Signal at Top
		751 MHz	751 MHz
13 / 10M	0+1+2	42.35	42.20

4TX

Band / BW	Chain	QPSK_NB-IoT Signal at Bottom	QPSK_NB-IoT Signal at Top
		751 MHz	751 MHz
13 / 10M	0+1+2+3	43.57	43.40

ERP Power (dBm)

1TX

Band / BW	Chain	QPSK_NB-IoT Signal at Bottom	QPSK_NB-IoT Signal at Top
		751 MHz	751 MHz
13 / 10M	0	43.21	43.30
	1	43.59	43.20
	2	43.48	43.33
	3	43.32	43.10

2TX

Band / BW	Chain	QPSK_NB-IoT Signal at Bottom	QPSK_NB-IoT Signal at Top
		751 MHz	751 MHz
13 / 10M	0+1	46.41	46.26
	2+3	46.41	46.23

3TX

Band / BW	Chain	QPSK_NB-IoT Signal at Bottom	QPSK_NB-IoT Signal at Top
		751 MHz	751 MHz
13 / 10M	0+1+2	48.20	48.05

4TX

Band / BW	Chain	QPSK_NB-IoT Signal at Bottom	QPSK_NB-IoT Signal at Top
		751 MHz	751 MHz
13 / 10M	0+1+2+3	49.42	49.25

Note:

1. ERP (dBm) = Conducted Output Power (dBm) + antenna gain (dBi) – 2.15.
2. The 2TX MIMO power was select worst 2 chain total calculation.
3. The 3TX MIMO power was select worst 3 chain total calculation.

NB-IOT In-Band

Channel Bandwidth: 5MHz

Conducted Output Power (dBm)

1TX

Band / BW	Chain	QPSK_NB-IoT Signal at Bottom			QPSK_NB-IoT Signal at Top		
		748.5 MHz	751 MHz	753.5 MHz	748.5 MHz	751 MHz	753.5 MHz
13 / 5M	0	37.26	37.86	37.56	37.80	37.69	37.59
	1	37.28	37.83	37.77	37.87	37.65	37.80
	2	37.25	37.81	37.95	37.78	37.77	37.79
	3	37.18	37.55	37.69	37.75	37.79	37.73

2TX

Band / BW	Chain	QPSK_NB-IoT Signal at Bottom			QPSK_NB-IoT Signal at Top		
		748.5 MHz	751 MHz	753.5 MHz	748.5 MHz	751 MHz	753.5 MHz
13 / 5M	0+1	40.28	40.86	40.68	40.85	40.68	40.71
	2+3	40.23	40.69	40.83	40.78	40.79	40.77

3TX

Band / BW	Chain	QPSK_NB-IoT Signal at Bottom			QPSK_NB-IoT Signal at Top		
		748.5 MHz	751 MHz	753.5 MHz	748.5 MHz	751 MHz	753.5 MHz
13 / 5M	0+1+2	42.03	42.60	42.53	42.59	42.47	42.50

4TX

Band / BW	Chain	QPSK_NB-IoT Signal at Bottom			QPSK_NB-IoT Signal at Top		
		748.5 MHz	751 MHz	753.5 MHz	748.5 MHz	751 MHz	753.5 MHz
13 / 5M	0+1+2+3	43.26	43.78	43.77	43.82	43.75	43.75

ERP Power (dBm)

1TX

Band / BW	Chain	QPSK_NB-IoT Signal at Bottom			QPSK_NB-IoT Signal at Top		
		748.5 MHz	751 MHz	753.5 MHz	748.5 MHz	751 MHz	753.5 MHz
13 / 5M	0	43.11	43.71	43.41	43.65	43.54	43.44
	1	43.13	43.68	43.62	43.72	43.50	43.65
	2	43.10	43.66	43.80	43.63	43.62	43.64
	3	43.03	43.40	43.54	43.60	43.64	43.58

2TX

Band / BW	Chain	QPSK_NB-IoT Signal at Bottom			QPSK_NB-IoT Signal at Top		
		748.5 MHz	751 MHz	753.5 MHz	748.5 MHz	751 MHz	753.5 MHz
13 / 5M	0+1	46.13	46.71	46.53	46.70	46.53	46.56
	2+3	46.08	46.54	46.68	46.63	46.64	46.62

3TX

Band / BW	Chain	QPSK_NB-IoT Signal at Bottom			QPSK_NB-IoT Signal at Top		
		748.5 MHz	751 MHz	753.5 MHz	748.5 MHz	751 MHz	753.5 MHz
13 / 5M	0+1+2	47.88	48.45	48.38	48.44	48.32	48.35

4TX

Band / BW	Chain	QPSK_NB-IoT Signal at Bottom			QPSK_NB-IoT Signal at Top		
		748.5 MHz	751 MHz	753.5 MHz	748.5 MHz	751 MHz	753.5 MHz
13 / 5M	0+1+2+3	49.11	49.63	49.62	49.67	49.60	49.60

Note:

1. ERP (dBm) = Conducted Output Power (dBm) + antenna gain (dBi) – 2.15.
2. The 2TX MIMO power was select worst 2 chain total calculation.
3. The 3TX MIMO power was select worst 3 chain total calculation.

Channel Bandwidth: 10MHz

Conducted Output Power (dBm)

1TX

Band / BW	Chain	QPSK_NB-IoT Signal at Bottom	QPSK_NB-IoT Signal at Top
		751 MHz	751 MHz
13 / 10M	0	38.16	37.94
	1	38.08	38.10
	2	38.07	38.15
	3	38.21	38.20

2TX

Band / BW	Chain	QPSK_NB-IoT Signal at Bottom	QPSK_NB-IoT Signal at Top
		751 MHz	751 MHz
13 / 10M	0+1	41.13	41.03
	2+3	41.15	41.19

3TX

Band / BW	Chain	QPSK_NB-IoT Signal at Bottom	QPSK_NB-IoT Signal at Top
		751 MHz	751 MHz
13 / 10M	0+1+2	42.89	42.92

4TX

Band / BW	Chain	QPSK_NB-IoT Signal at Bottom	QPSK_NB-IoT Signal at Top
		751 MHz	751 MHz
13 / 10M	0+1+2+3	44.15	44.12

ERP Power (dBm)

1TX

Band / BW	Chain	QPSK_NB-IoT Signal at Bottom	QPSK_NB-IoT Signal at Top
		751 MHz	751 MHz
13 / 10M	0	44.01	43.79
	1	43.93	43.95
	2	43.92	44.00
	3	44.06	44.05

2TX

Band / BW	Chain	QPSK_NB-IoT Signal at Bottom	QPSK_NB-IoT Signal at Top
		751 MHz	751 MHz
13 / 10M	0+1	46.98	46.88
	2+3	47.00	47.04

3TX

Band / BW	Chain	QPSK_NB-IoT Signal at Bottom	QPSK_NB-IoT Signal at Top
		751 MHz	751 MHz
13 / 10M	0+1+2	48.74	48.77

4TX

Band / BW	Chain	QPSK_NB-IoT Signal at Bottom	QPSK_NB-IoT Signal at Top
		751 MHz	751 MHz
13 / 10M	0+1+2+3	50.00	49.97

Note:

4. ERP (dBm) = Conducted Output Power (dBm) + antenna gain (dBi) – 2.15.
5. The 2TX MIMO power was select worst 2 chain total calculation.
6. The 3TX MIMO power was select worst 3 chain total calculation.

4.2 Modulation Characteristics Measurement

4.2.1 Limits of Modulation Characteristics

N/A

4.2.2 Test Procedure

Connect the EUT to Communication Simulator via the antenna connector, the frequency band is set as EUT supported Modulation and Channels, the EUT output is matched with 50 ohm load, the waveform quality and constellation of the EUT was tested.

4.2.3 Test Setup

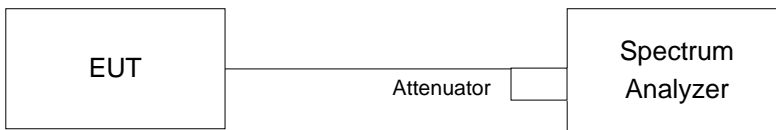

4.2.4 Test Results

NB-IoT Guard Band

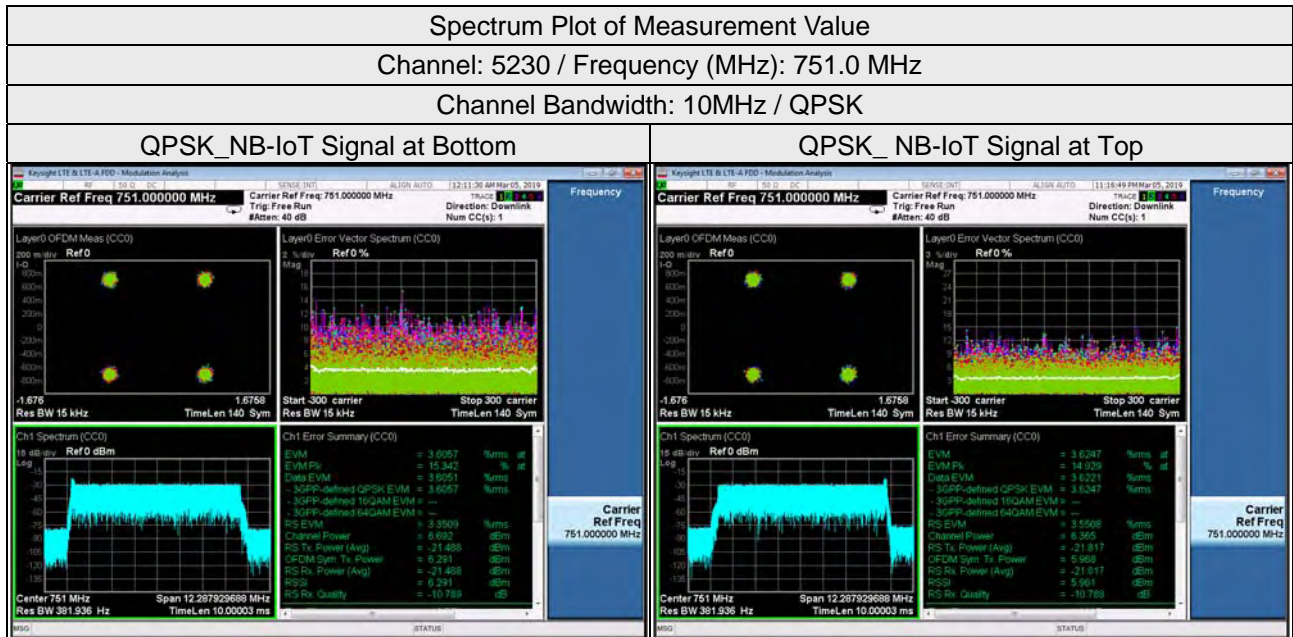

NB-IoT In-Band

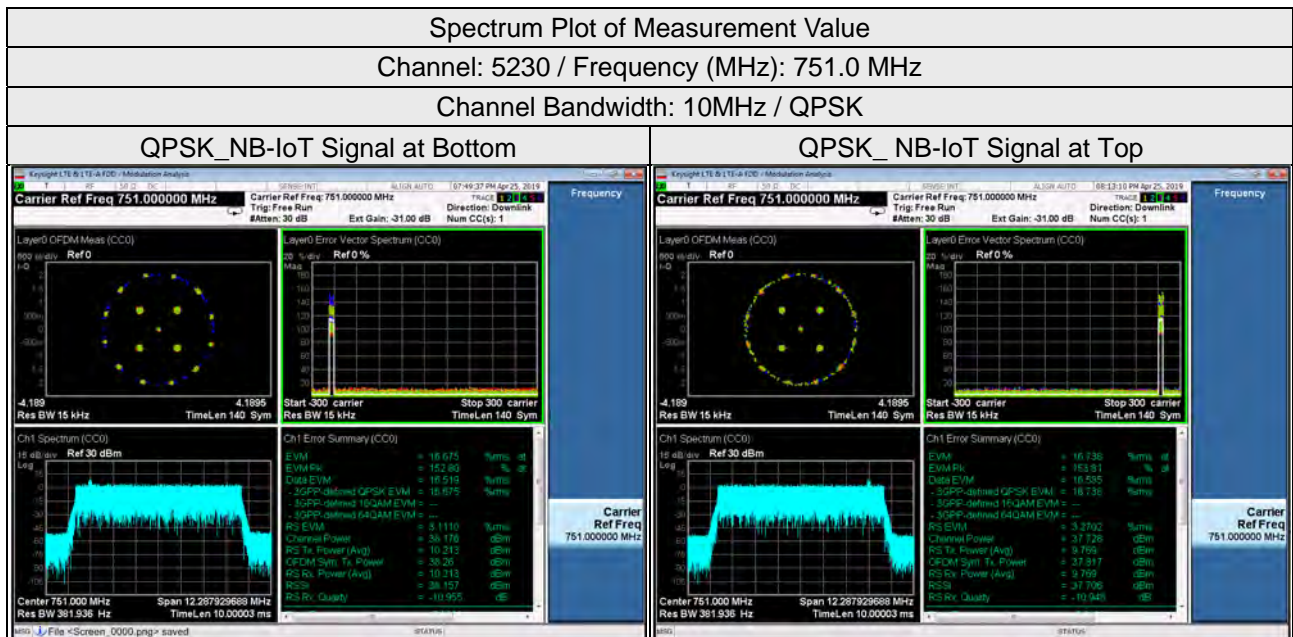

4.3 Frequency Stability Measurement

4.3.1 Limits of Frequency Stability Measurement

According to the FCC part 2.1055 shall be tested the frequency stability. The rule is defined that "The frequency stability shall be sufficient to ensure that the fundamental emission stays within the authorized frequency block." The test extreme voltage is according to the 2.1055(d)(1) Vary primary supply voltage from 85 to 115 percent of the nominal value for other than hand carried battery equipment and the extreme temperature rule is comply with specification of EUT $-30^{\circ}\text{C} \sim 50^{\circ}\text{C}$.

4.3.2 Test Procedure

- Device is placed at the oven room. The oven room could control the temperatures and humidity. Power warm up is at least 15 min and power applied should perform before recording frequency error.
- EUT is connected the external power supply to control the DC input power. The test voltage range is from minimum to maximum working voltage. Each step shall be record the frequency error rate.
- The temperature range step is 10 degrees in this test items. All temperature levels shall be hold the $\pm 0.5^{\circ}\text{C}$ during the measurement testing. The each temperature step shall be at least 0.5 hours, consider the EUT could be test under the stability condition.

Note: The frequency error was recorded frequency error from the communication simulator.

4.3.3 Test Setup

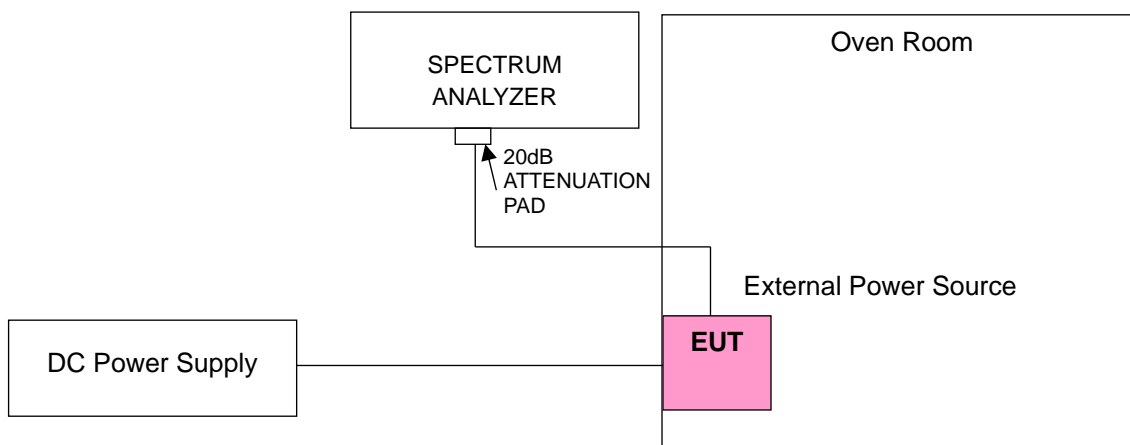

4.3.4 Test Results

NB-IOT Guard Band

Frequency Error vs. Voltage

Voltage (Volts)	LTE Band 13 Guard Band
	Frequency error (ppm)
55.2	0.04000
48	0.00918
40.8	0.02508

Note: The applicant defined the normal working voltage is from 40.8Vdc to 55.2Vdc.

Frequency Error vs. Temperature

Temp. (°C)	LTE Band 13 Guard Band
	Frequency error (ppm)
50	0.04596
40	0.00120
30	0.00578
20	0.00918
10	0.01447
0	0.06035
-10	0.02784
-20	0.04055
-30	0.02073

NB-IOT In-Band

Frequency Error vs. Voltage

Voltage (Volts)	LTE Band 13 In Band
	Frequency error (ppm)
55.2	0.002
48	0.002
40.8	0.005

Note: The applicant defined the normal working voltage is from 40.8Vdc to 55.2Vdc.

Frequency Error vs. Temperature

Temp. (°C)	LTE Band 13 In Band
	Frequency error (ppm)
50	-0.004
40	-0.004
30	-0.003
20	-0.003
10	0.003
0	0.003
-10	0.003
-20	0.003
-30	0.002

4.4 Emission Bandwidth Measurement

4.4.1 Limits of Emission Bandwidth Measurement

Emission bandwidth is defined as the width of the signal between two points, one below the carrier center frequency and one above the carrier center frequency, outside of which all emissions are attenuated at least 26dB below the transmitter power.

4.4.2 Test Procedure

The transmitter output was connected to the spectrum analyzer through an attenuator. The bandwidth of the fundamental frequency was measured by spectrum analyzer with RBW = 51kHz and VBW = 150kHz (Channel Bandwidth: 5MHz), RBW = 100kHz and VBW = 300kHz (Channel Bandwidth: 10MHz). The 26dB bandwidth is defined as the total spectrum the power of which is higher than peak power minus 26dB.

4.4.3 Test Setup

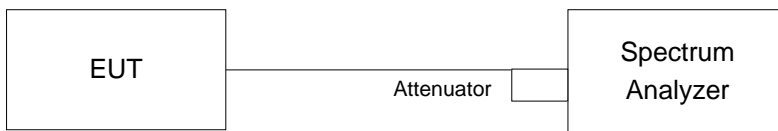

4.4.4 Test Result

NB-IoT Guard Band

Channel Bandwidth: 10MHz									
26dBc Bandwidth (MHz)									
Channel	Frequency (MHz)	QPSK_IoT Signal at bottom				QPSK_IoT Signal at top			
		Chain 0	Chain 1	Chain 2	Chain 3	Chain 0	Chain 1	Chain 2	Chain 3
5230	751.0	9.65	9.65	9.67	9.65	9.67	9.63	9.66	9.67

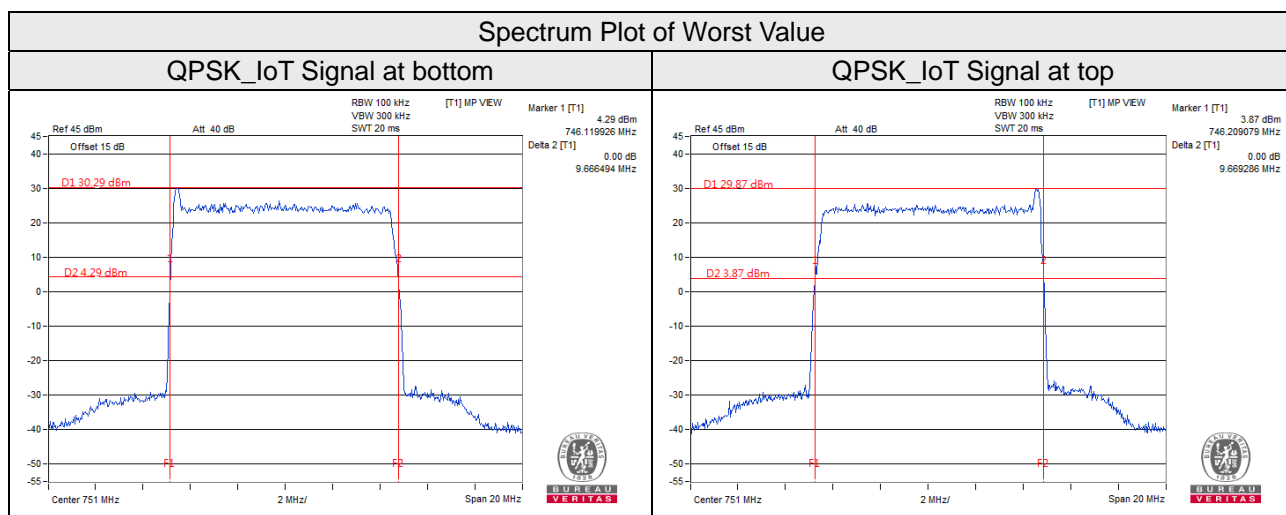

Channel Bandwidth: 10MHz									
Occupied Bandwidth (MHz)									
Channel	Frequency (MHz)	QPSK_IoT Signal at bottom				QPSK_IoT Signal at top			
		Chain 0	Chain 1	Chain 2	Chain 3	Chain 0	Chain 1	Chain 2	Chain 3
5230	751.0	9.16	9.20	9.16	9.16	9.16	9.20	9.16	9.20

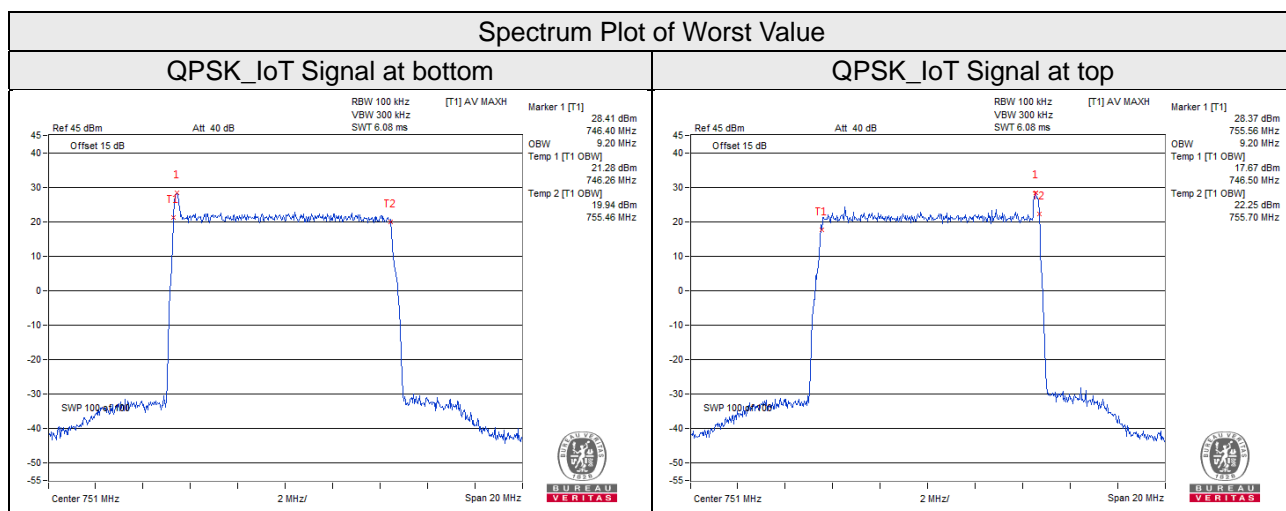

NB-IoT In-Band

Channel Bandwidth: 5MHz									
26dBc Bandwidth (MHz)									
Channel	Frequency (MHz)	QPSK_IoT Signal at bottom				QPSK_IoT Signal at top			
		Chain 0	Chain 1	Chain 2	Chain 3	Chain 0	Chain 1	Chain 2	Chain 3
5205	748.5	4.73	4.72	4.74	4.73	4.73	4.73	4.73	4.73
5230	751.0	4.72	4.74	4.72	4.72	4.73	4.71	4.74	4.73
5255	753.5	4.73	4.71	4.72	4.73	4.73	4.72	4.73	4.74

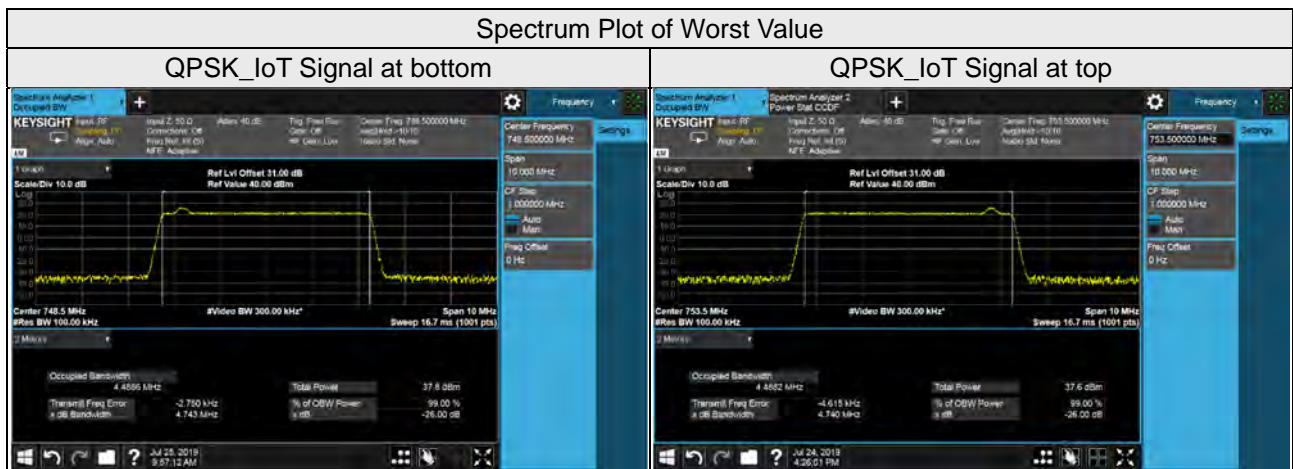

Channel Bandwidth: 5MHz									
Occupied Bandwidth (MHz)									
Channel	Frequency (MHz)	QPSK_IoT Signal at bottom				QPSK_IoT Signal at top			
		Chain 0	Chain 1	Chain 2	Chain 3	Chain 0	Chain 1	Chain 2	Chain 3
5205	748.5	4.49	4.49	4.49	4.49	4.49	4.49	4.49	4.49
5230	751.0	4.49	4.49	4.49	4.49	4.49	4.49	4.49	4.49
5255	753.5	4.49	4.49	4.49	4.49	4.49	4.49	4.49	4.49

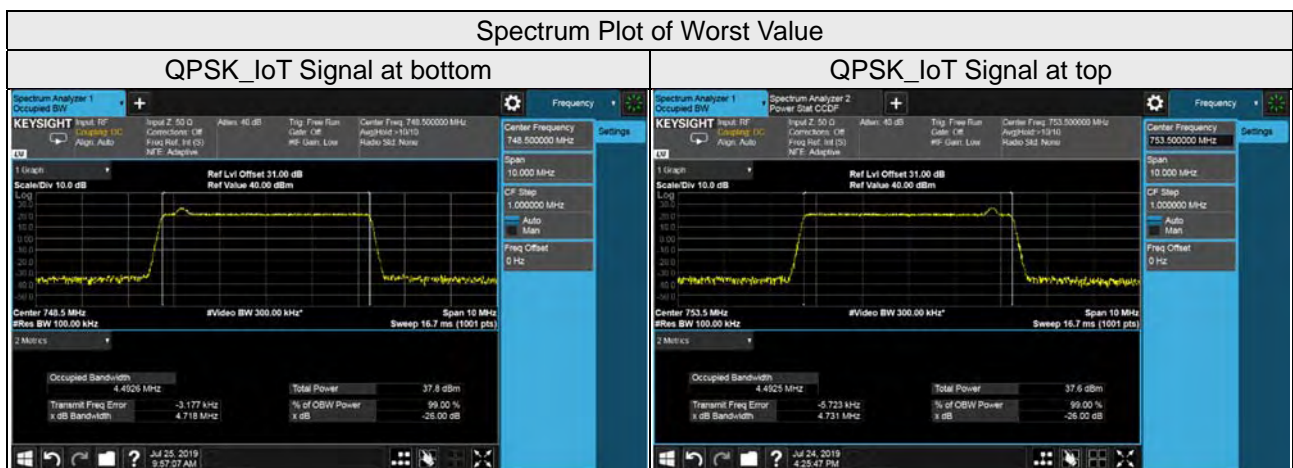

Channel Bandwidth: 10MHz									
26dBc Bandwidth (MHz)									
Channel	Frequency (MHz)	QPSK_IoT Signal at bottom				QPSK_IoT Signal at top			
		Chain 0	Chain 1	Chain 2	Chain 3	Chain 0	Chain 1	Chain 2	Chain 3
5230	751.0	9.233	9.241	9.240	9.267	9.299	9.236	9.231	9.243

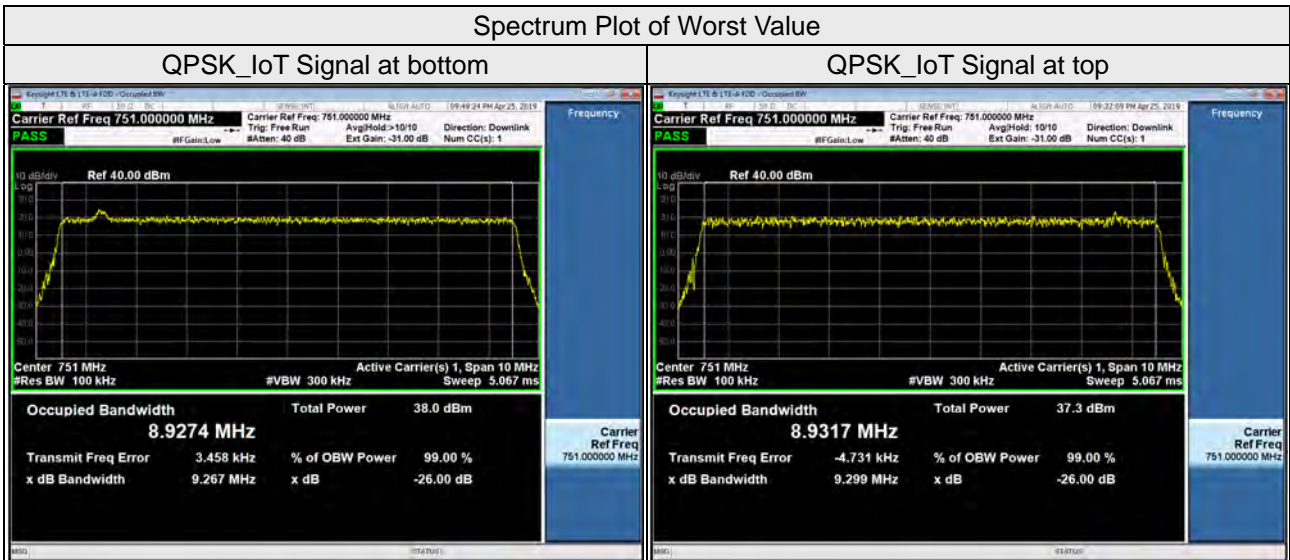

Channel Bandwidth: 10MHz									
Occupied Bandwidth (MHz)									
Channel	Frequency (MHz)	QPSK_IoT Signal at bottom				QPSK_IoT Signal at top			
		Chain 0	Chain 1	Chain 2	Chain 3	Chain 0	Chain 1	Chain 2	Chain 3
5230	751.0	8.93	8.93	8.92	8.93	8.93	8.92	8.92	8.93

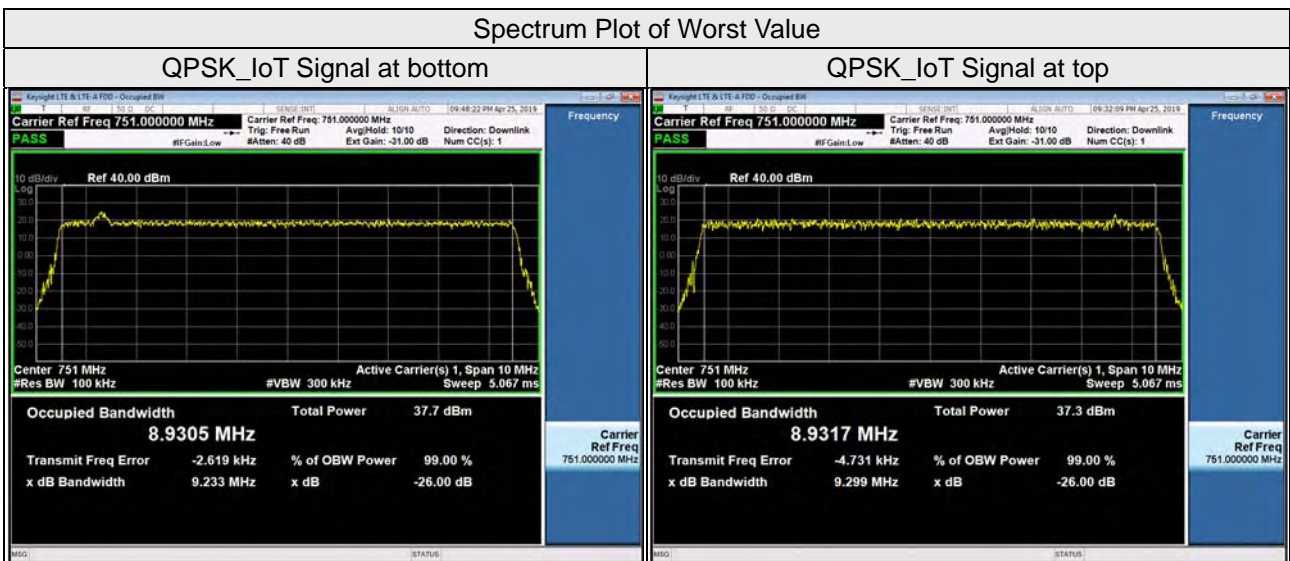

4.5 Band Edge Measurement

4.5.1 Limits of Band Edge Measurement

According to FCC 27.53(c), for operations in the 747 to 762 MHz band and the 777 to 792 MHz band, the power of any emission outside the licensee's frequency band(s) of operation shall be attenuated below the transmitter power (P) within the licensed band(s) of operation, measured watts, in accordance with the following:

- (1) On any frequency outside the 747 to 762 MHz band, the power of any emission shall be attenuated outside the band below the transmitter power (P) by at least $43 + 10 \log (P)$ dB.

Note: The Device has 4x4 MIMO function, so the limit of spurious emissions needs to be reduced by $10 \log(\text{Numbers}_{\text{Ant}})$ according to FCC KDB 662911 D01 guidance.

{The limits is adjusted to $-13\text{dBm} - 10 * \log(4) = -19.02\text{dBm}$ }

4.5.2 Test Setup

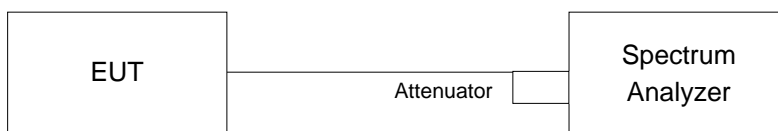

4.5.3 Test Procedures

- a. The EUT was set up for the rated peak power. The power was measured with Spectrum Analyzer. All measurements were done at 3 channels: low, middle and high operational frequency range.
- b. The center frequency of spectrum is the band edge frequency and span is RBW = 51kHz and VBW = 150kHz (Channel Bandwidth: 5MHz), RBW = 100kHz and VBW = 300kHz (Channel Bandwidth: 10MHz).
- c. Record the max trace plot into the test report.

4.5.4 Test Results

NB-IoT Guard Band

Channel Bandwidth: 10MHz

QPSK_IoT Signal at Bottom (Chain 0)

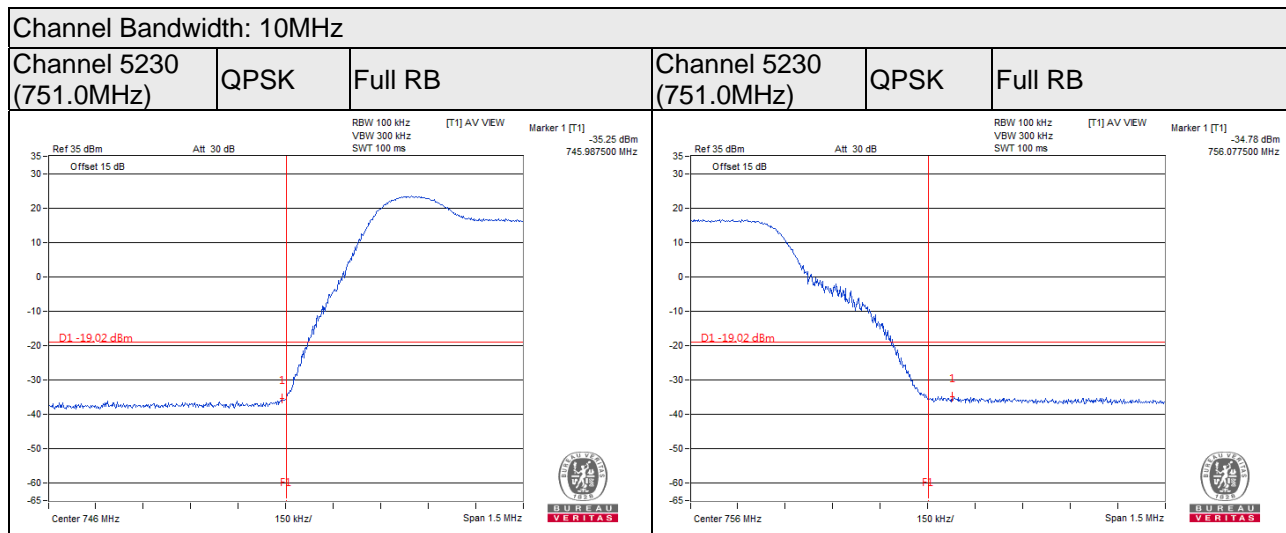

QPSK_IoT Signal at Bottom (Chain 1)

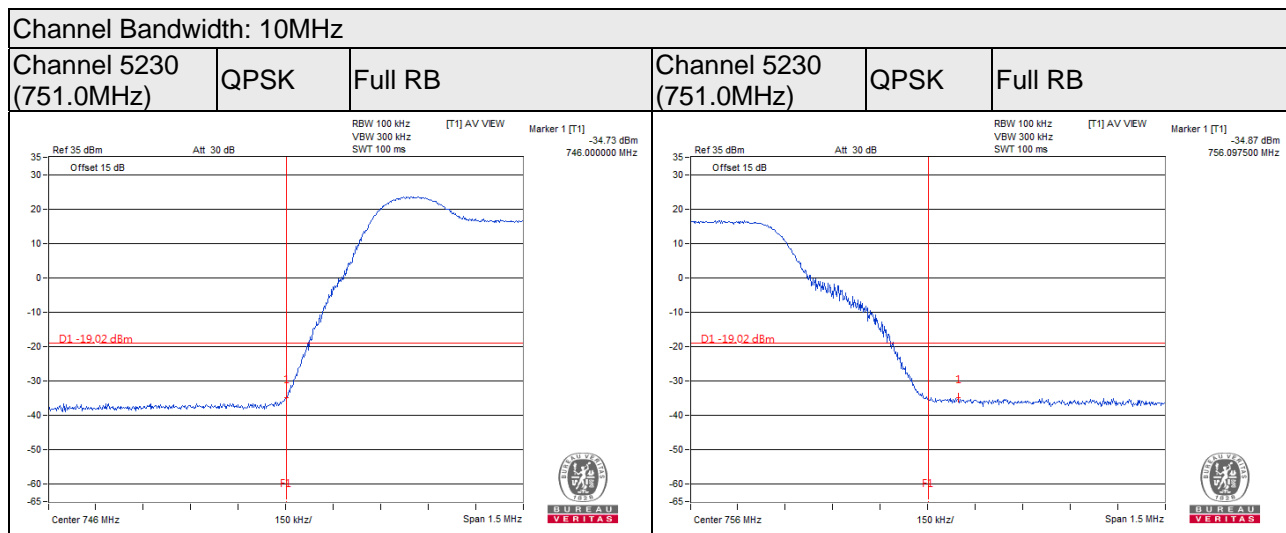

QPSK_IoT Signal at Bottom (Chain 2)

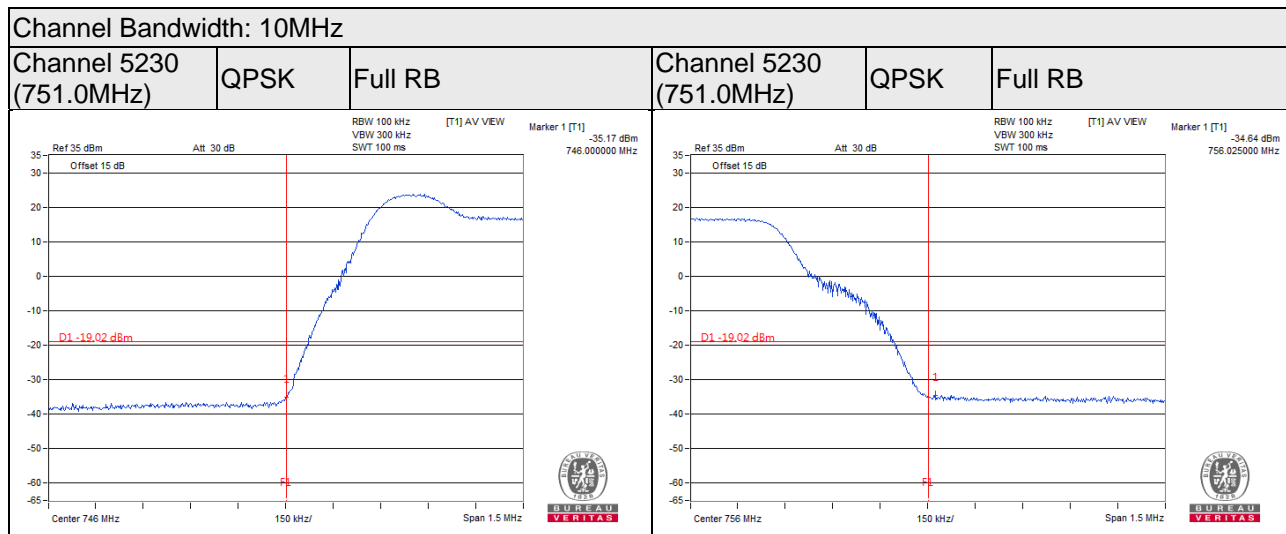

QPSK_IoT Signal at Bottom (Chain 3)

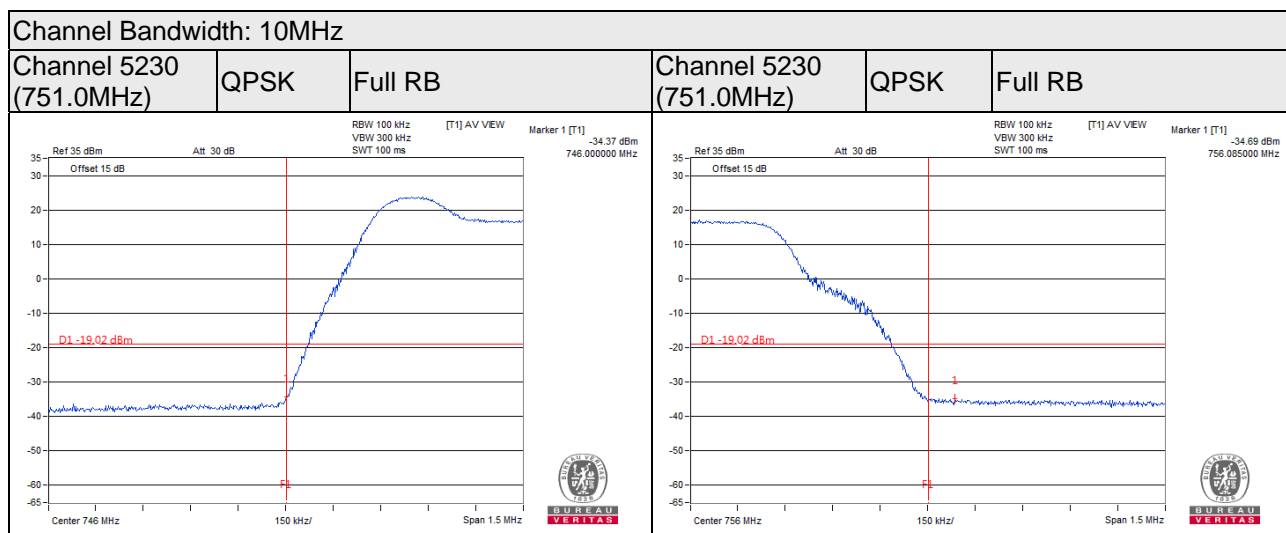

QPSK_IoT Signal at Top (Chain 0)

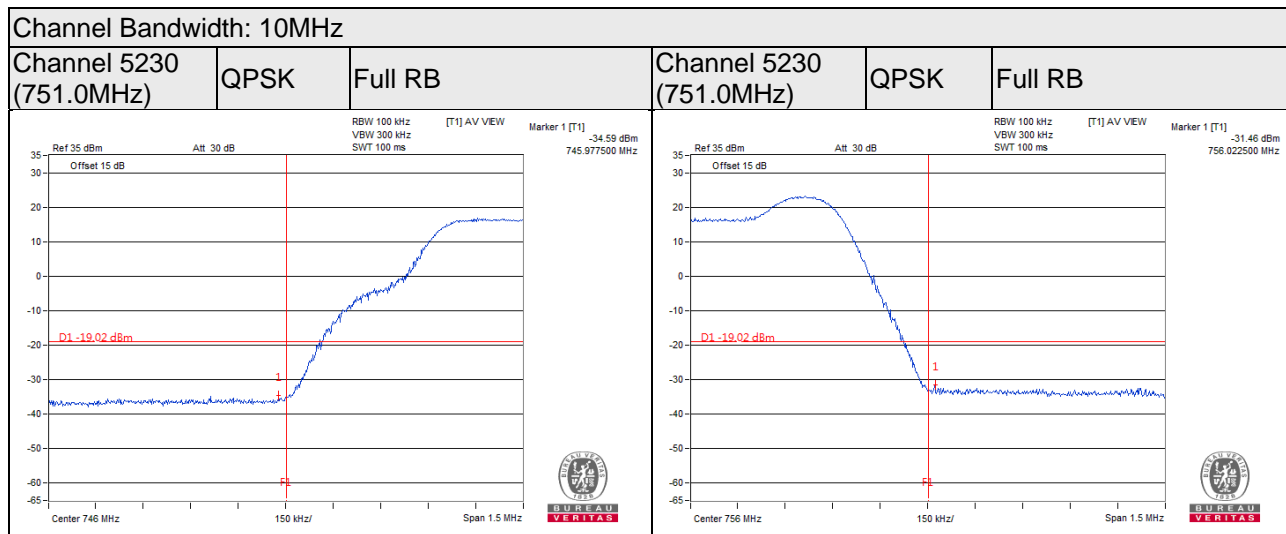

QPSK_IoT Signal at Top (Chain 1)

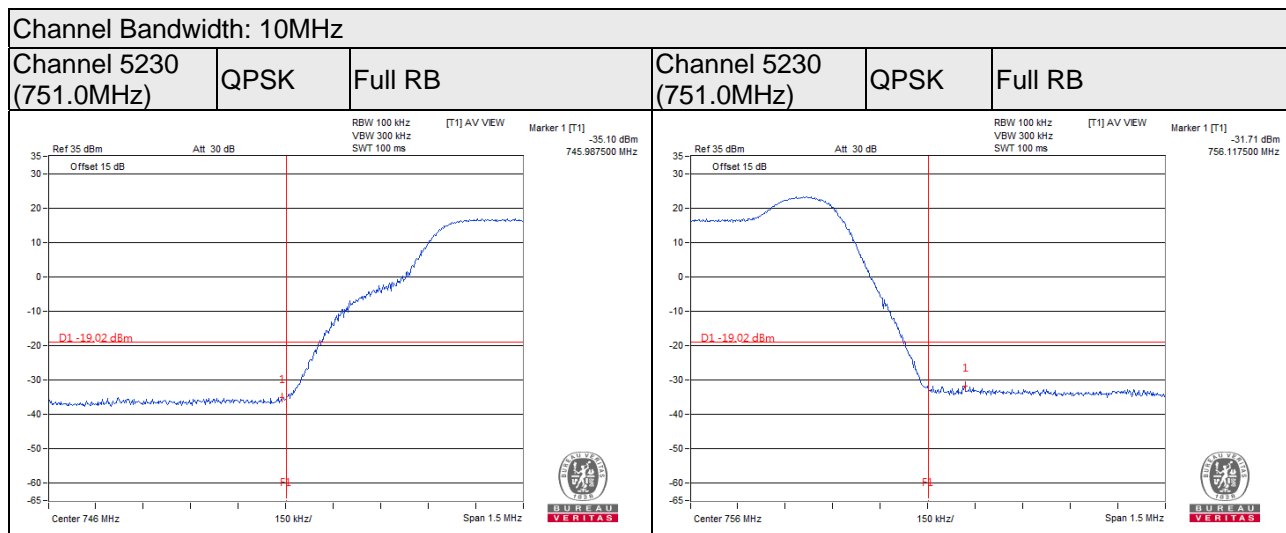

QPSK_IoT Signal at Top (Chain 2)

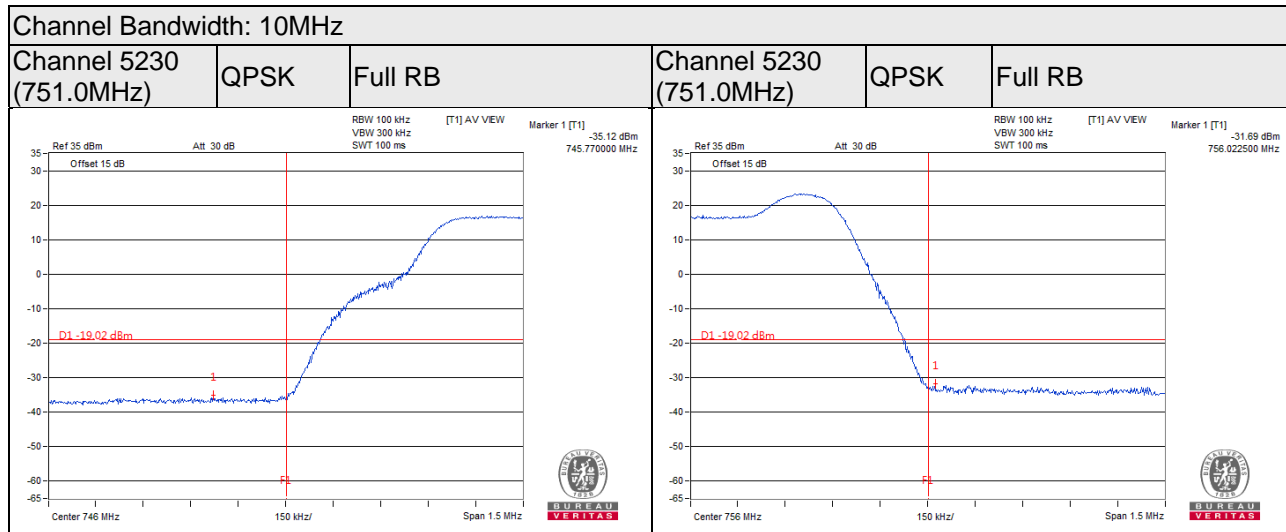

QPSK_IoT Signal at Top (Chain 3)

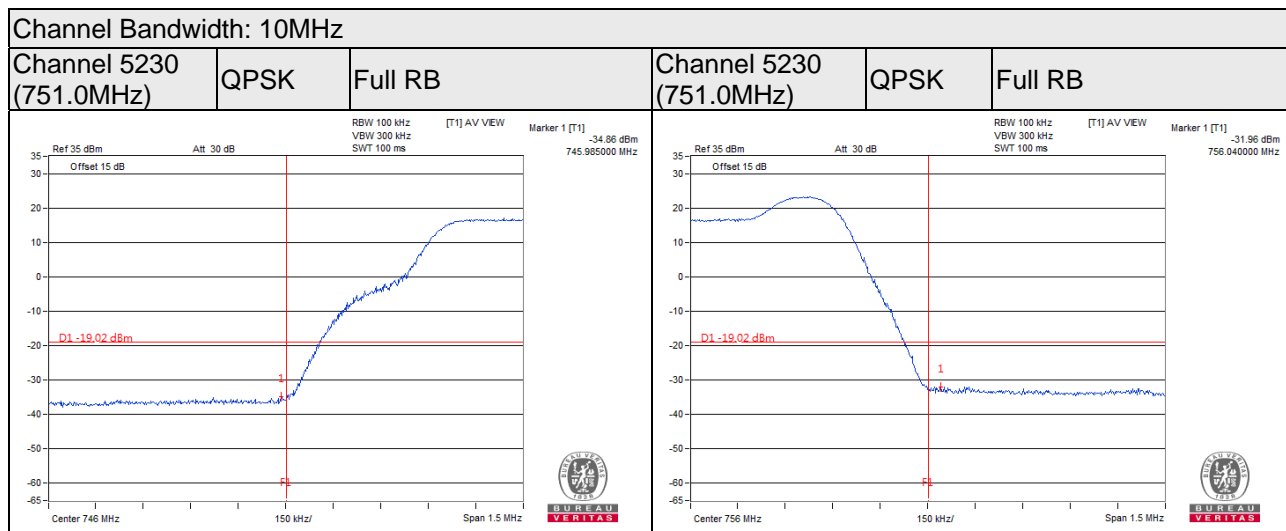

NB-IoT In-Band

Channel Bandwidth: 5MHz

QPSK_IoT Signal at Bottom (Chain 0)

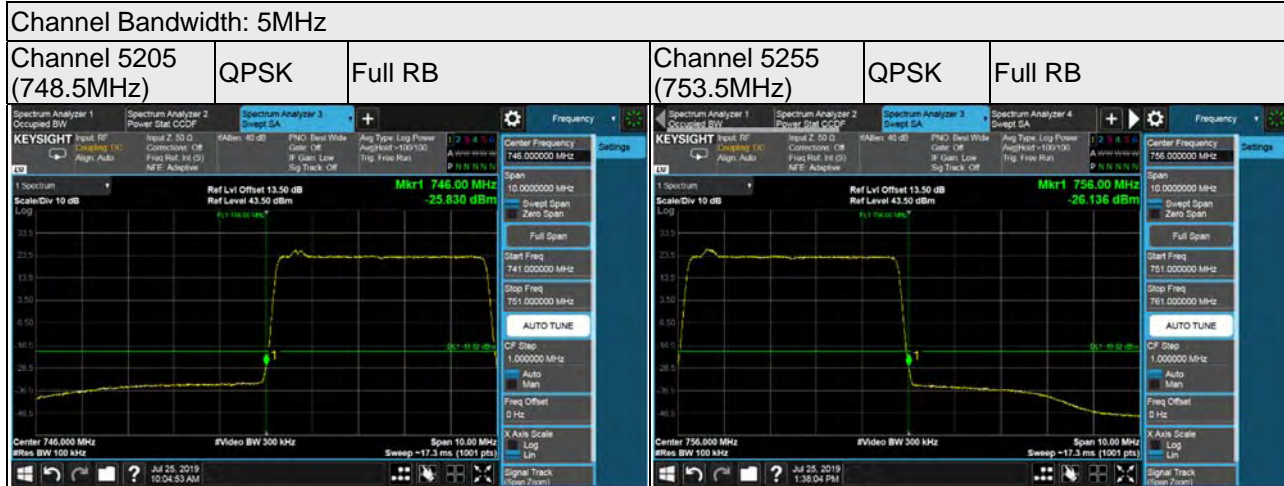

QPSK_IoT Signal at Bottom (Chain 1)

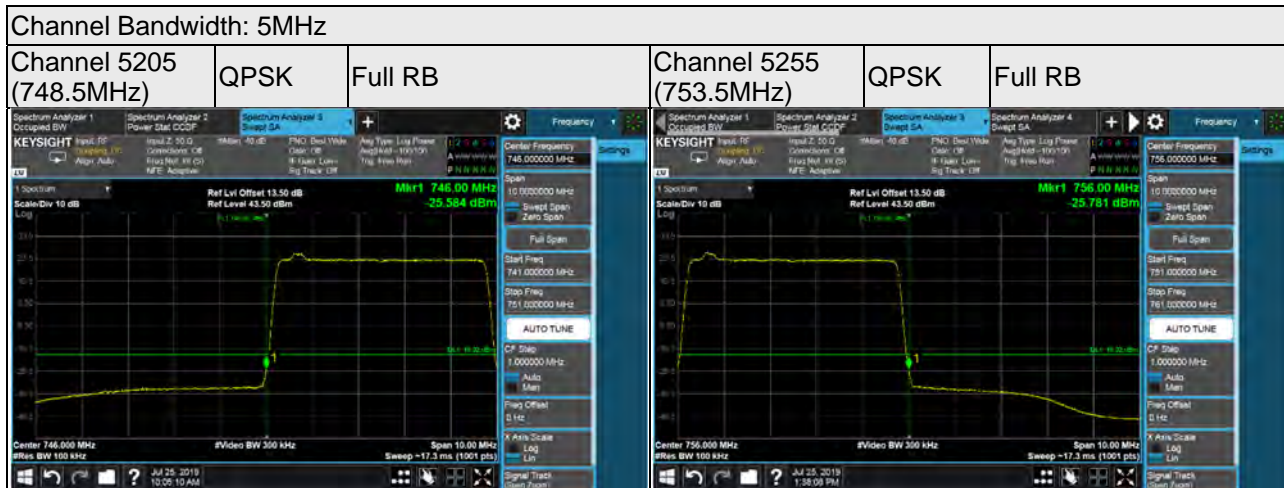

QPSK_IoT Signal at Bottom (Chain 2)

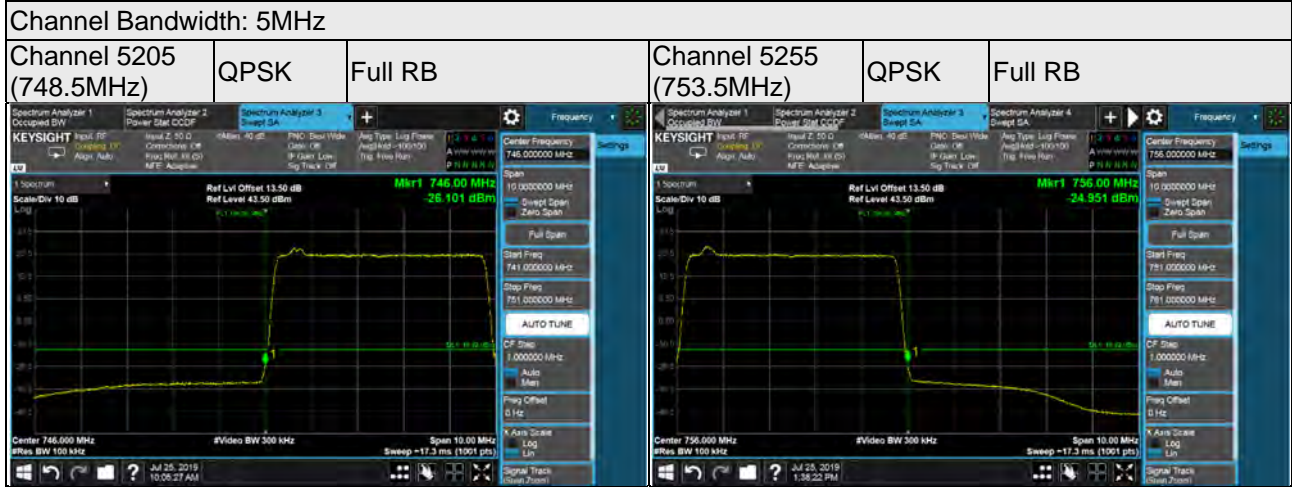

QPSK_IoT Signal at Bottom (Chain 3)

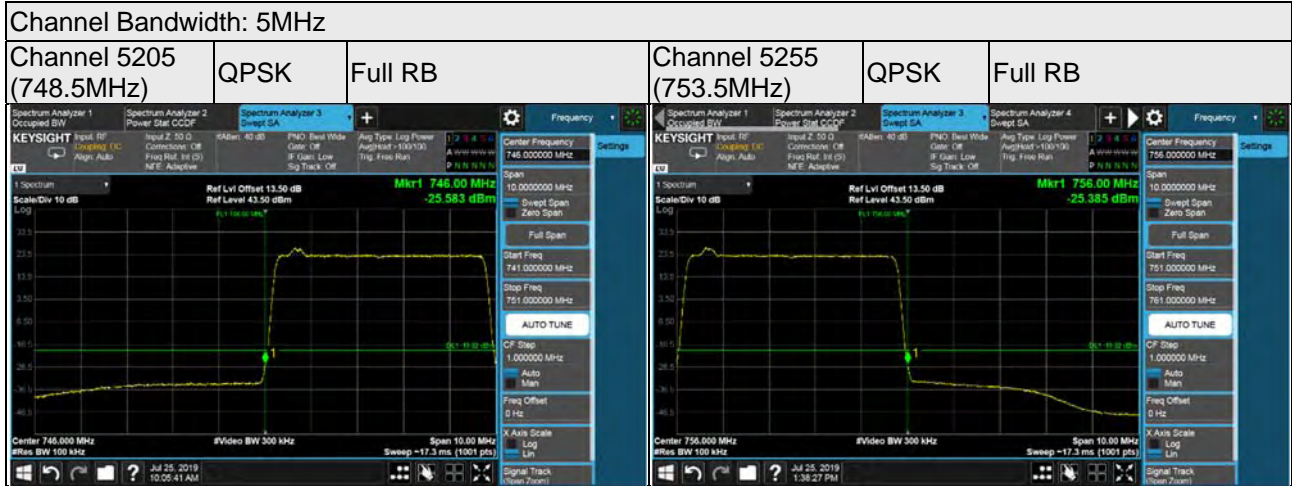

QPSK_IoT Signal at Top (Chain 0)

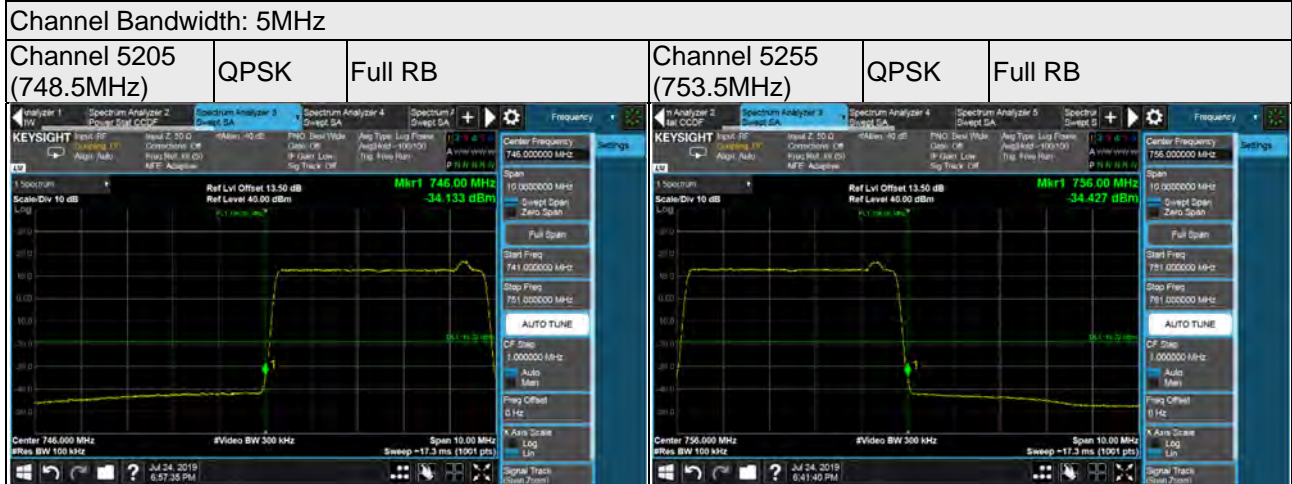

QPSK_IoT Signal at Top (Chain 1)

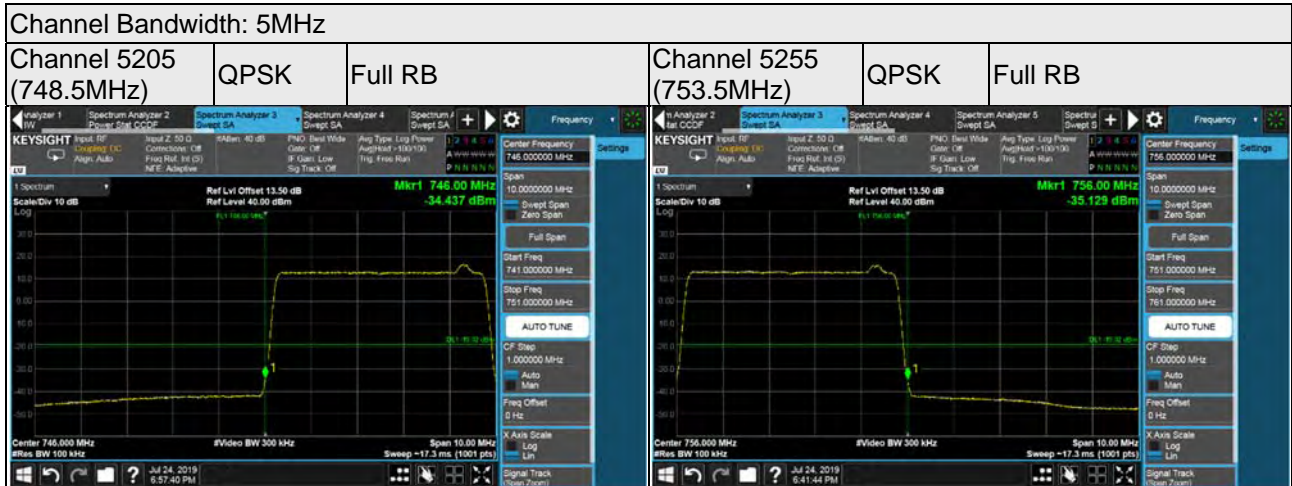

QPSK_IoT Signal at Top (Chain 2)

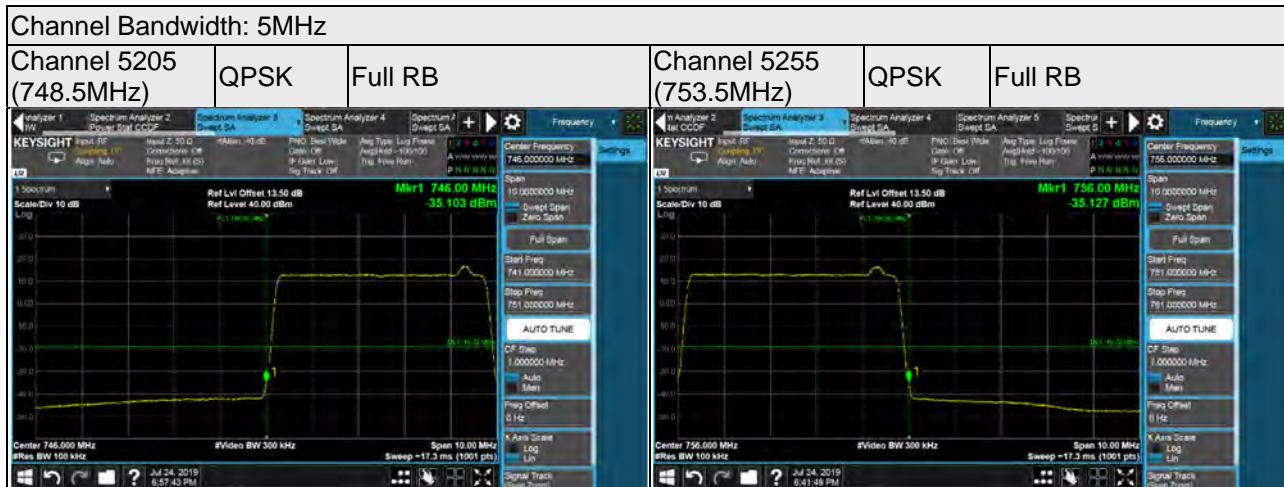

QPSK_IoT Signal at Top (Chain 3)

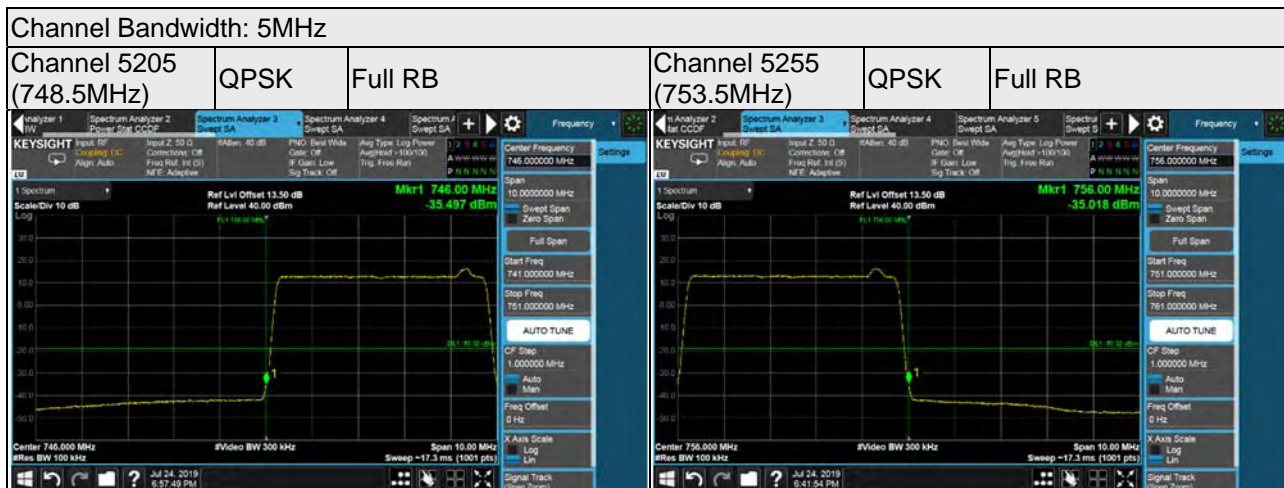

Channel Bandwidth: 10MHz

QPSK_IoT Signal at Bottom (Chain 0)

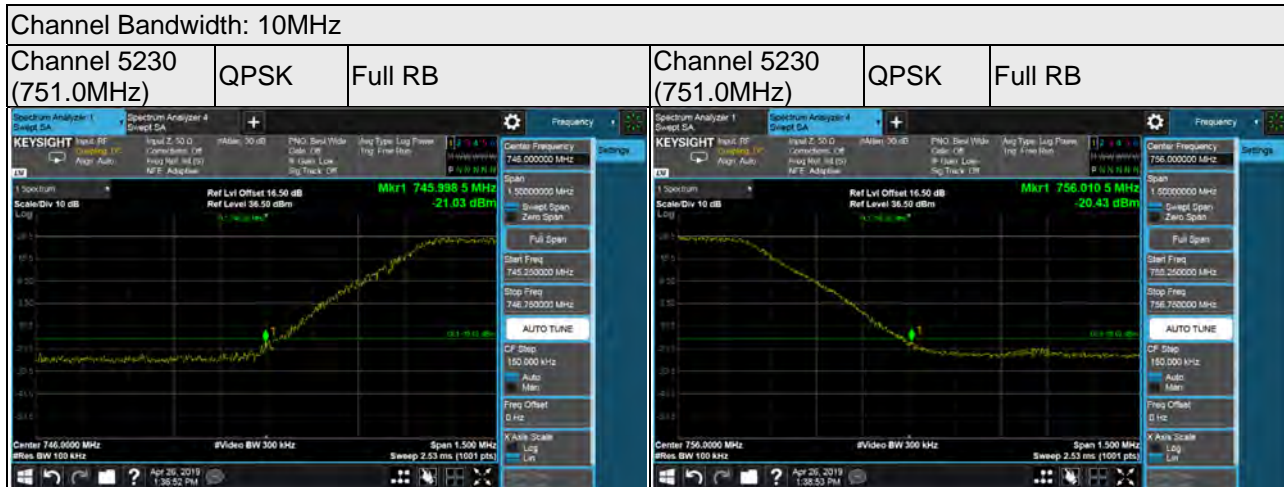

QPSK_IoT Signal at Bottom (Chain 1)

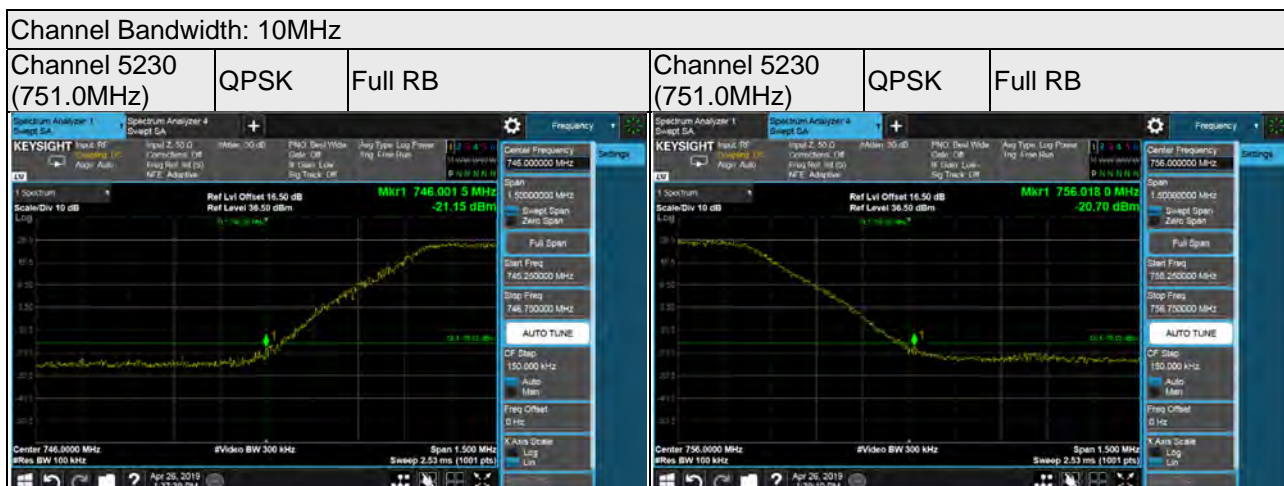

QPSK_IoT Signal at Bottom (Chain 2)

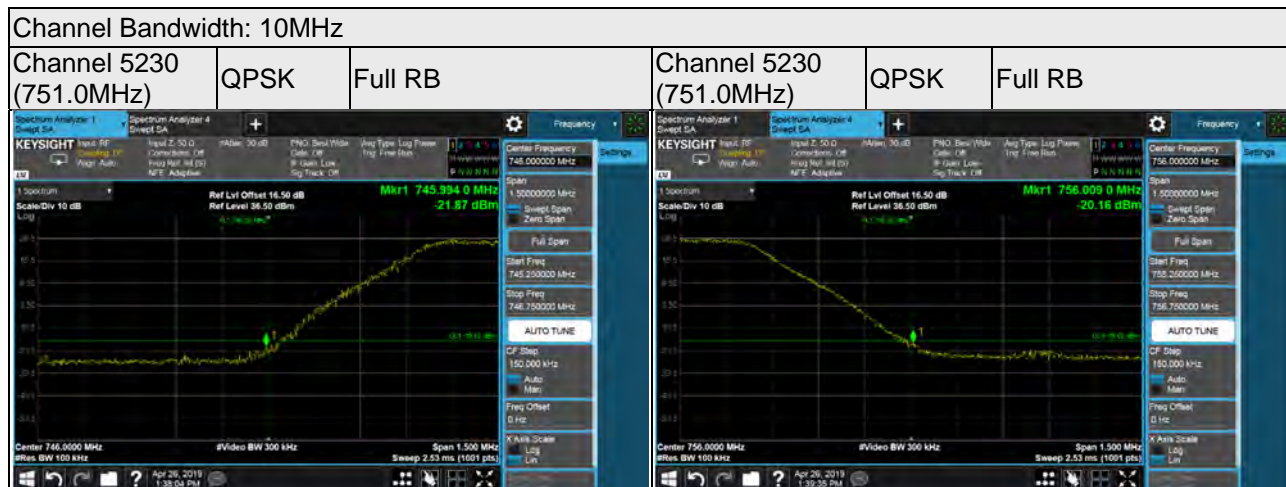

QPSK_IoT Signal at Bottom (Chain 3)

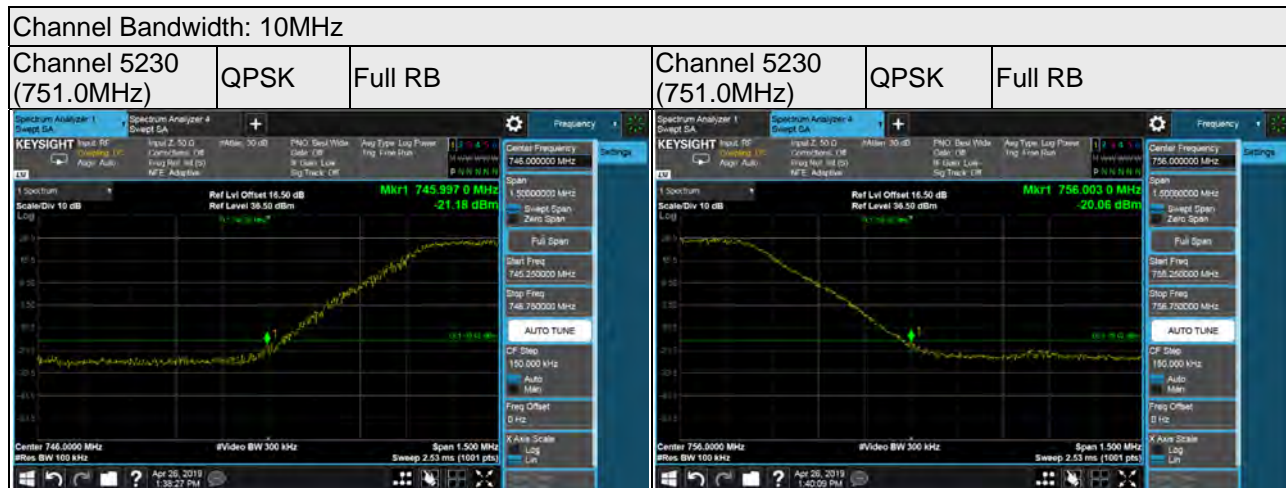

QPSK_IoT Signal at Top (Chain 0)

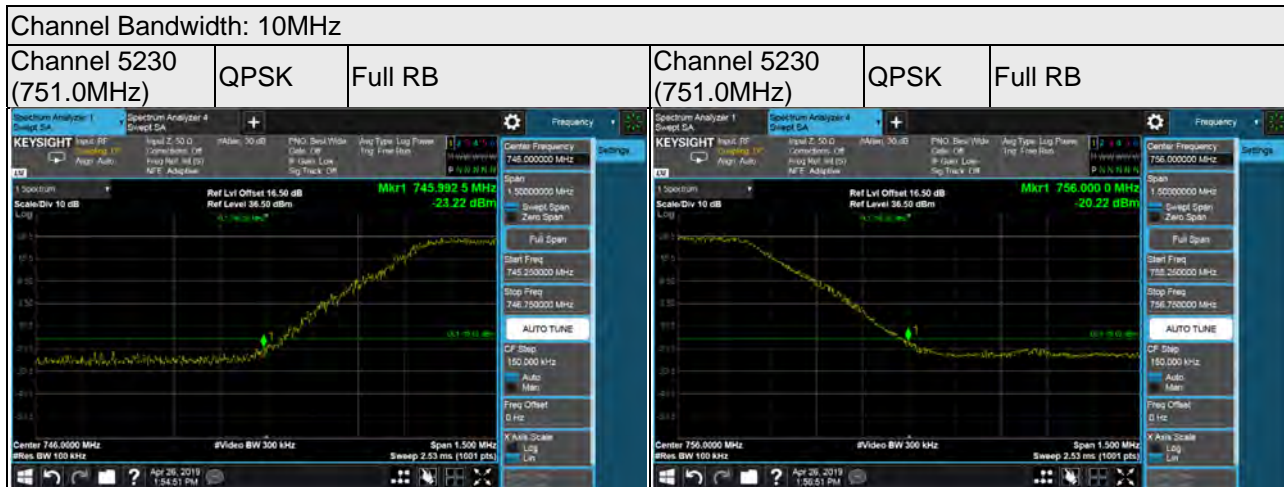

QPSK_IoT Signal at Top (Chain 1)

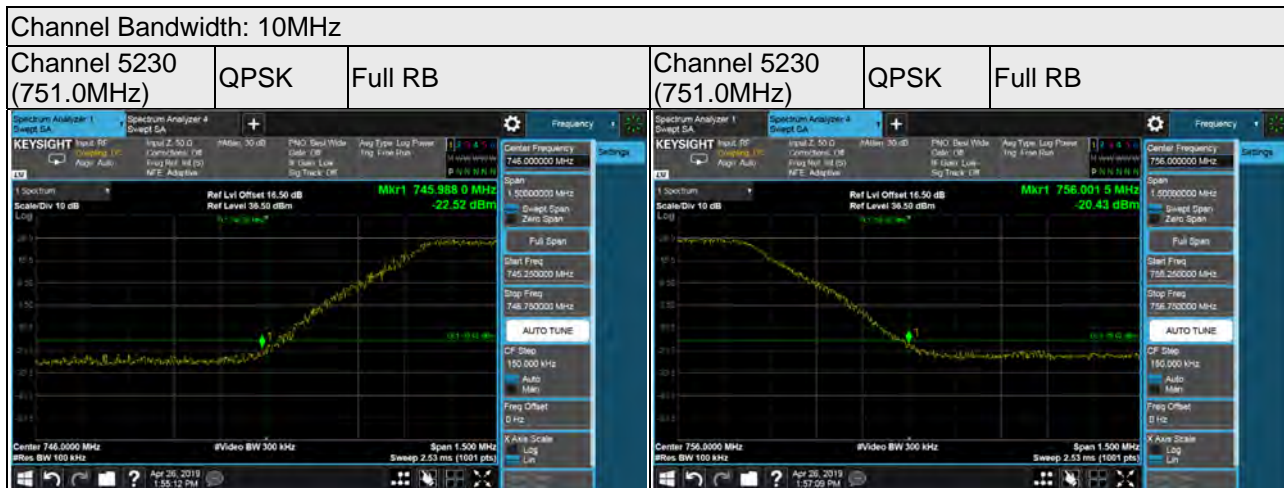

QPSK_IoT Signal at Top (Chain 2)

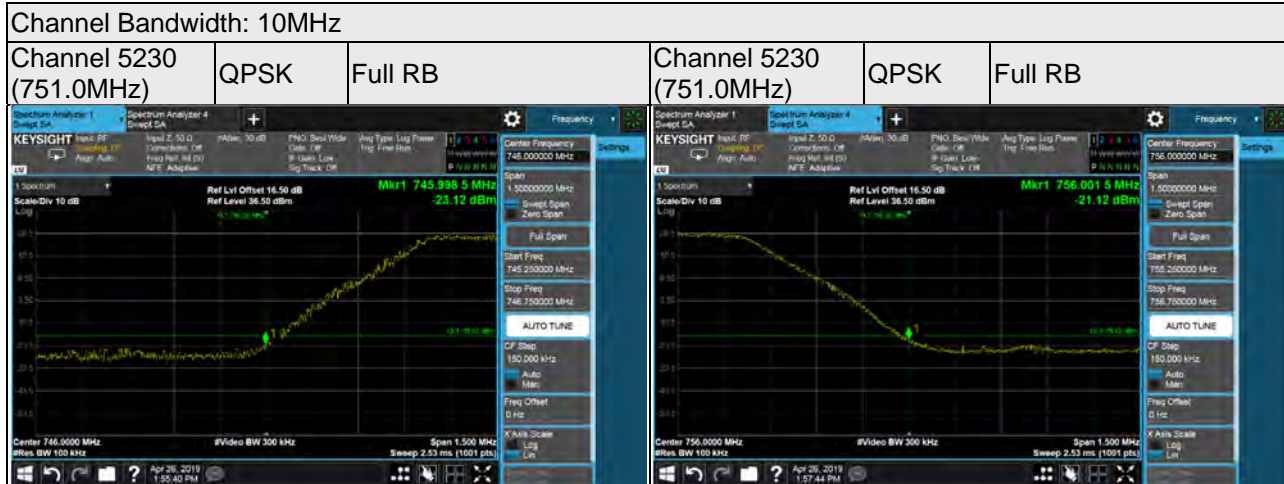

QPSK_IoT Signal at Top (Chain 3)

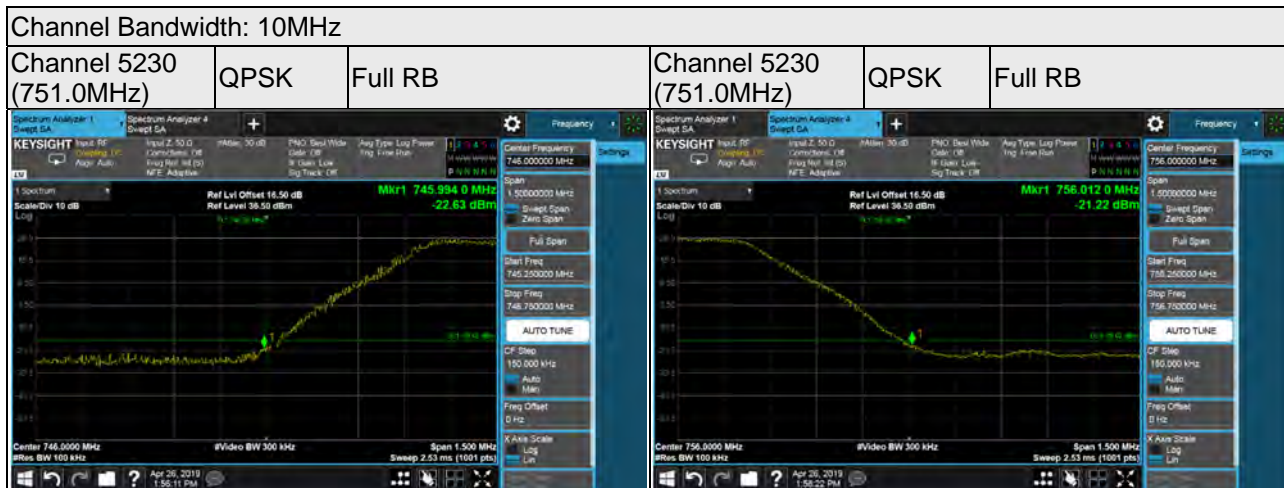

4.6 Peak to Average Ratio

4.6.1 Limits of Peak to Average Ratio Measurement

In measuring transmissions in this band using an average power technique, the peak to-average ratio (PAR) of the transmission may not exceed 13 dB

4.6.2 Test Setup

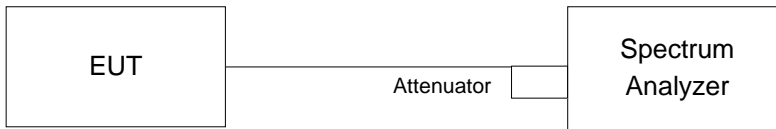

4.6.3 Test Procedures

- Set resolution/measurement bandwidth \geq signal's occupied bandwidth;
- Set the number of counts to a value that stabilizes the measured CCDF curve;
- Record the maximum PAPR level associated with a probability of 0.1%.

4.6.4 Test Results

NB-IoT Guard Band

Channel Bandwidth: 10MHz									
Peak To Average Ratio (dB)									
Channel	Frequency (MHz)	QPSK_IoT Signal at bottom				QPSK_IoT Signal at top			
		Chain 0	Chain 1	Chain 2	Chain 3	Chain 0	Chain 1	Chain 2	Chain 3
5230	751.0	7.24	7.23	7.22	7.23	7.22	7.22	7.22	7.23

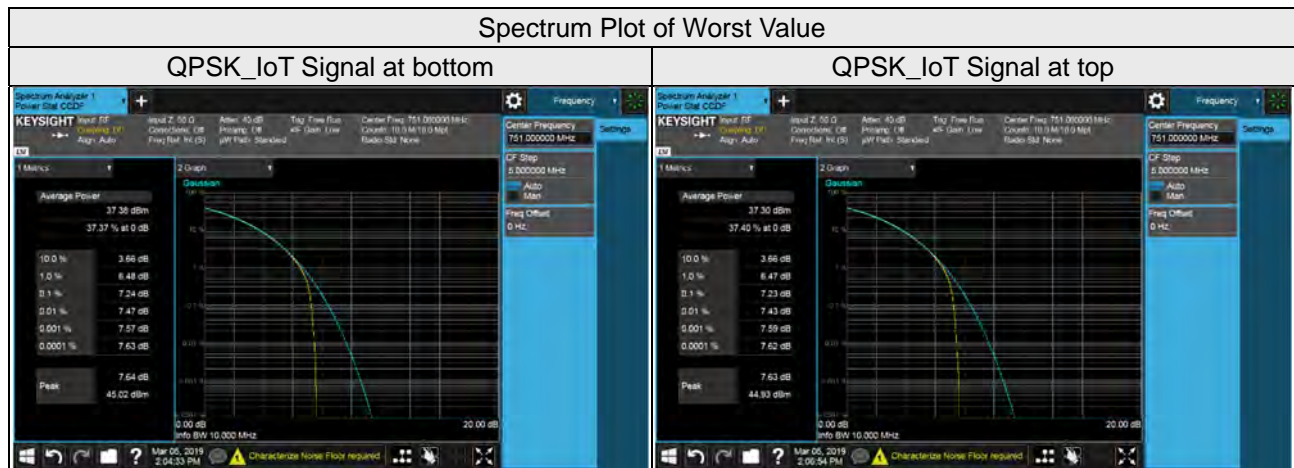

NB-IoT In-Band

Channel Bandwidth: 5MHz									
Peak To Average Ratio (dB)									
Channel	Frequency (MHz)	QPSK_IoT Signal at bottom				QPSK_IoT Signal at top			
		Chain 0	Chain 1	Chain 2	Chain 3	Chain 0	Chain 1	Chain 2	Chain 3
5205	748.5	7.39	7.38	7.39	7.39	7.38	7.38	7.38	7.39
5230	751.0	7.38	7.38	7.38	7.38	7.37	7.38	7.37	7.38
5255	753.5	7.39	7.39	7.39	7.39	7.38	7.38	7.38	7.38

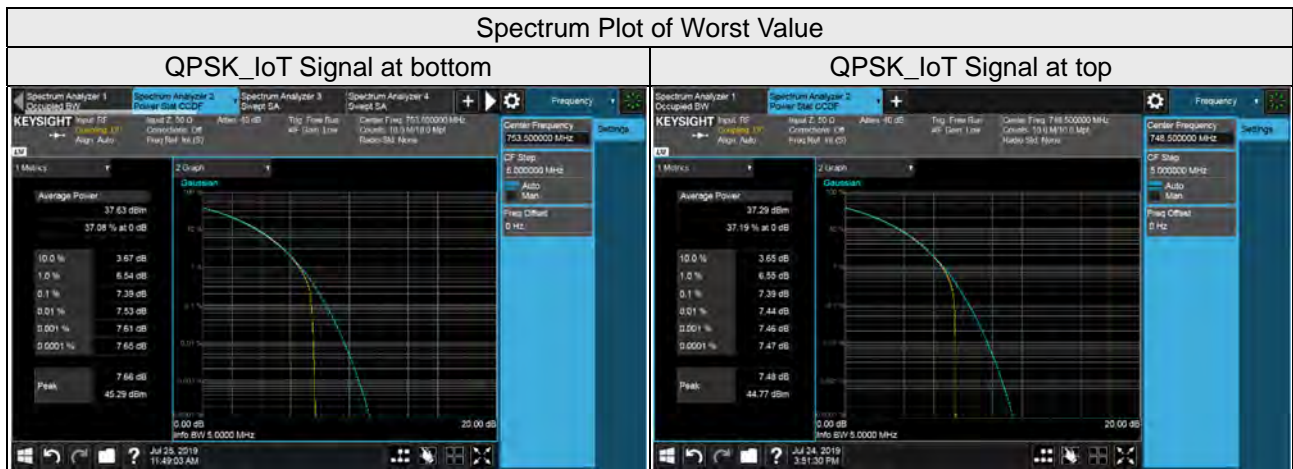

Channel Bandwidth: 10MHz									
Peak To Average Ratio (dB)									
Channel	Frequency (MHz)	QPSK_IoT Signal at bottom				QPSK_IoT Signal at top			
		Chain 0	Chain 1	Chain 2	Chain 3	Chain 0	Chain 1	Chain 2	Chain 3
5230	751.0	7.34	7.34	7.33	7.32	7.34	7.32	7.32	7.32

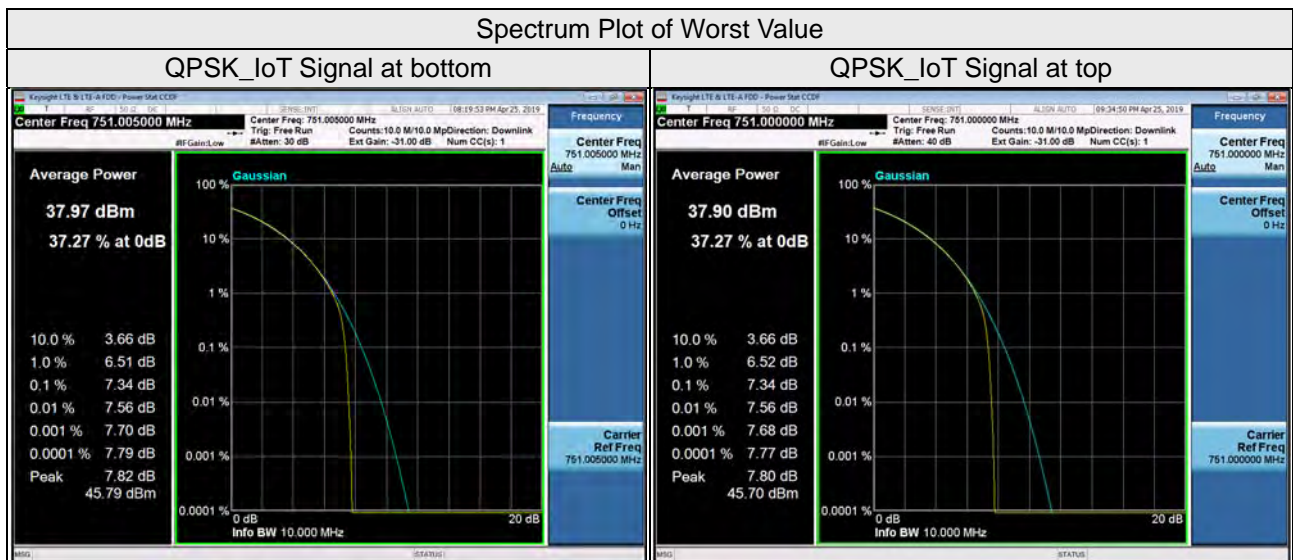

4.7 Conducted Spurious Emissions

4.7.1 Limits of Conducted Spurious Emissions Measurement

According to FCC 27.53(c) For operations in the 746-758 MHz band and the 776-788 MHz band, the power of any emission outside the licensee's frequency band(s) of operation shall be attenuated below the transmitter power (P) within the licensed band(s) of operation, measured in watts, in accordance with the following:

- (1) On any frequency outside the 746-758 MHz band, the power of any emission shall be attenuated outside the band below the transmitter power (P) by at least $43 + 10 \log (P)$ dB;

Note: The Device has 4x4 MIMO function, so the limit of spurious emissions needs to be reduced by $10\log(\text{Numbers}_{\text{Ant}})$ according to FCC KDB 662911 D01 guidance.

{The limits is adjusted to $-13\text{dBm} - 10*\log(4) = -19.02\text{dBm}$ }

- (2) On all frequencies between 763-775 MHz and 793-805 MHz, by a factor not less than $76 + 10 \log (P)$ dB in a 6.25 kHz band segment, for base and fixed stations;

Note: The Device has 4x4 MIMO function, so the limit of spurious emissions needs to be reduced by $10\log(\text{Numbers}_{\text{Ant}})$ according to FCC KDB 662911 D01 guidance.

{ $10\log(10\text{kHz}/6.25\text{kHz}) = 2.04\text{dB}$,

The limits is adjusted to $-46\text{dBm} + 2.04\text{dB} - 10*\log(4) = -49.98\text{dBm}$ }

Emissions in the band 1559-1610 MHz shall be limited to -70 dBW/MHz equivalent isotropically radiated power (EIRP) for wideband signals, and -80dBW EIRP for discrete emission of less than 700Hz bandwidth.

{The limits is adjusted to $-40\text{dBm} (-70\text{dBW}) - 10*\log(4) = -46.02\text{dBm}$ }

4.7.2 Test Setup

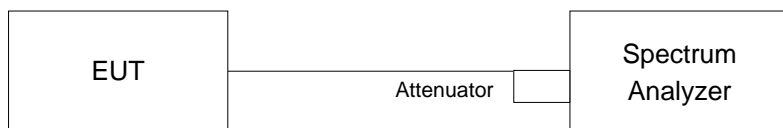

4.7.3 Test Procedure

- All measurements were done at 3 channels: low, middle and high operational frequency range.
- When the spectrum scanned from 9kHz to 26.5GHz, it shall be connected to the attenuator with the carried frequency.

4.7.4 Test Results

NB-IoT Guard Band

Channel Bandwidth: 10MHz

QPSK_IoT Signal at Bottom (Chain 0)

Channel Band width: 10MHz

Channel 5230 (751.0MHz)

Frequency Range : 9kHz~763MHz

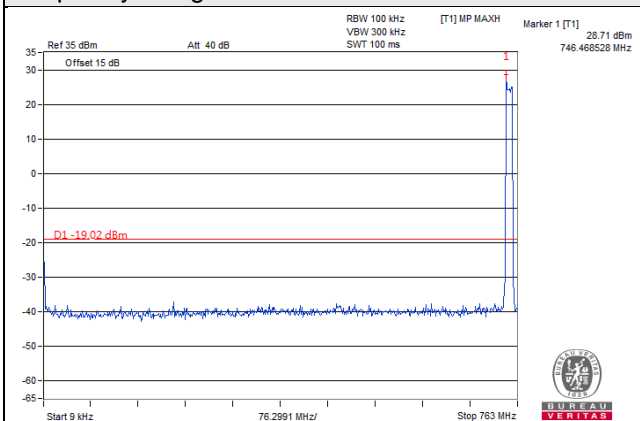

Frequency Range : 763MHz~775MHz

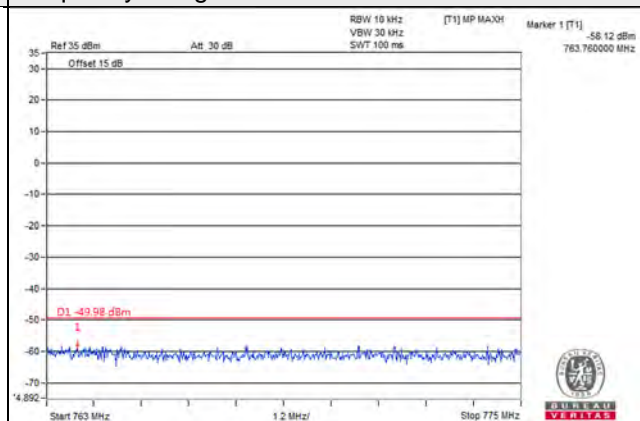

Frequency Range : 775MHz~793MHz

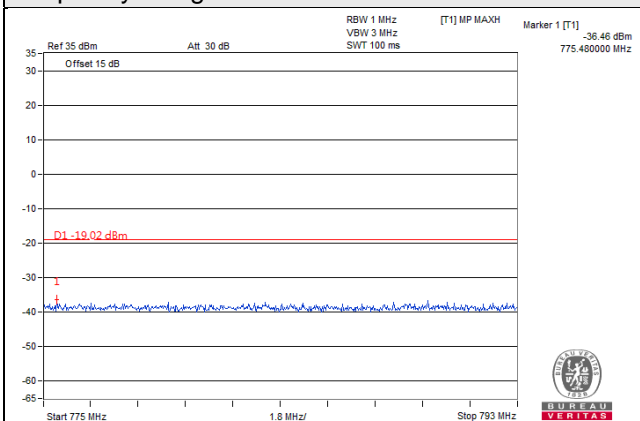

Frequency Range : 793MHz~805MHz

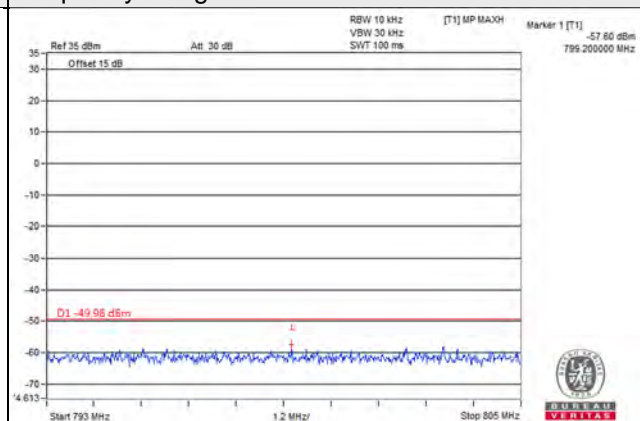

Frequency Range : 805MHz~1.559GHz

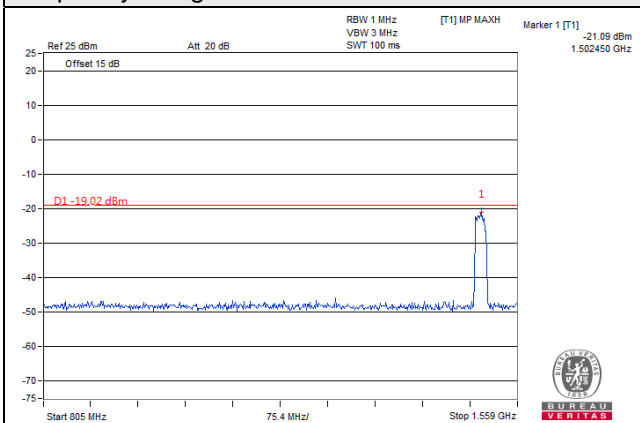

Frequency Range : 1.559GHz~1.610GHz

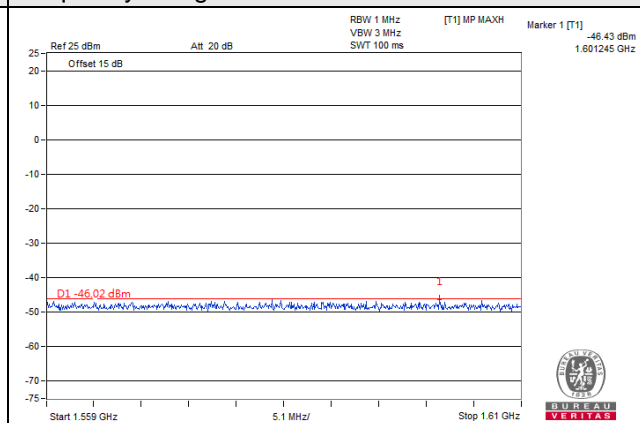

Frequency Range : 1.610GHz~9GHz

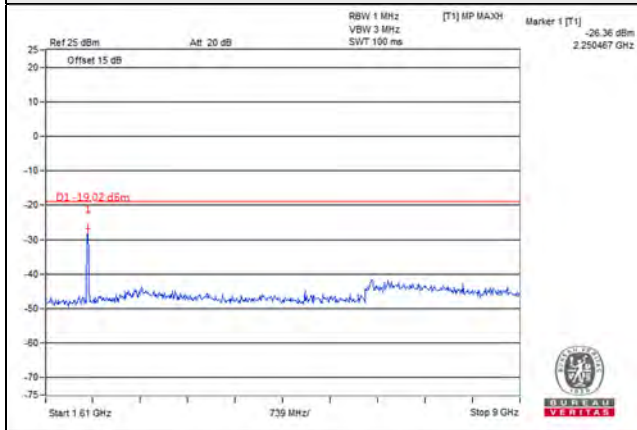

QPSK_IoT Signal at Bottom (Chain 1)

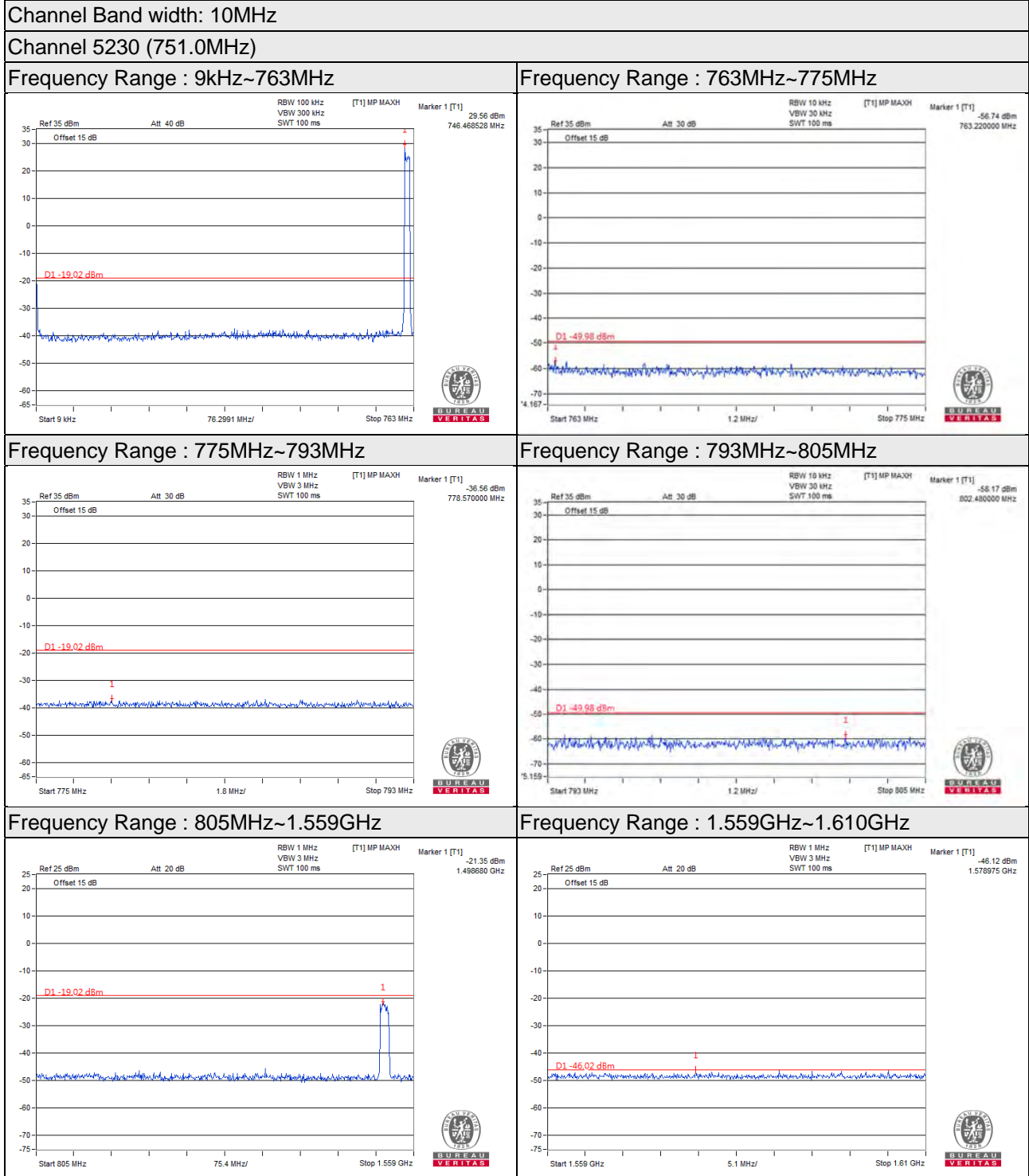

Frequency Range : 1.610GHz~9GHz

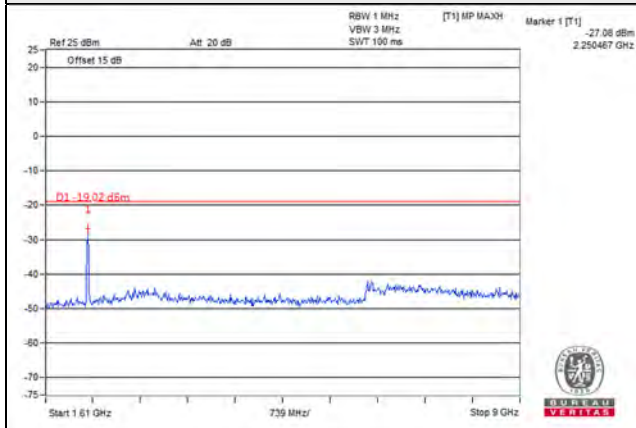

QPSK_IoT Signal at Bottom (Chain 2)



Frequency Range : 1.610GHz~9GHz

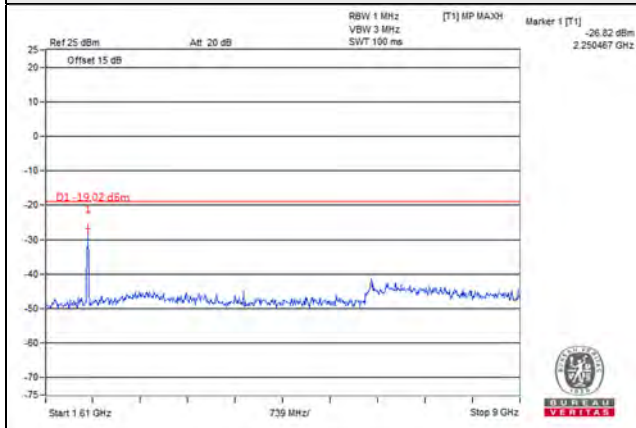

QPSK_IoT Signal at Bottom (Chain 3)

Channel Band width: 10MHz

Channel 5230 (751.0MHz)

Frequency Range : 9kHz~763MHz

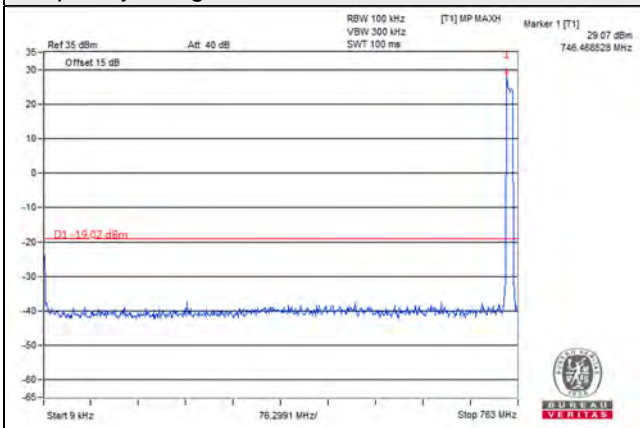

Frequency Range : 763MHz~775MHz

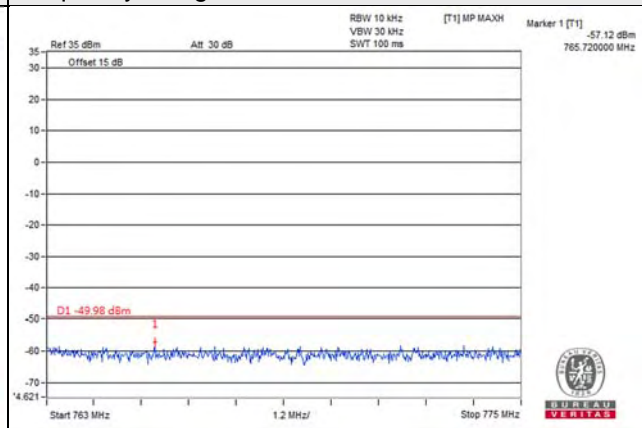

Frequency Range : 775MHz~793MHz

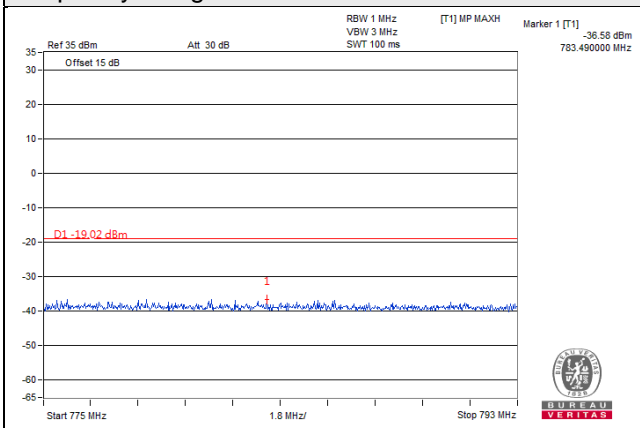

Frequency Range : 793MHz~805MHz

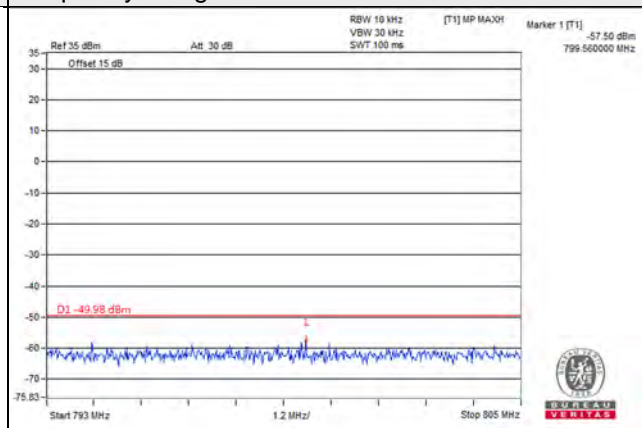

Frequency Range : 805MHz~1.559GHz

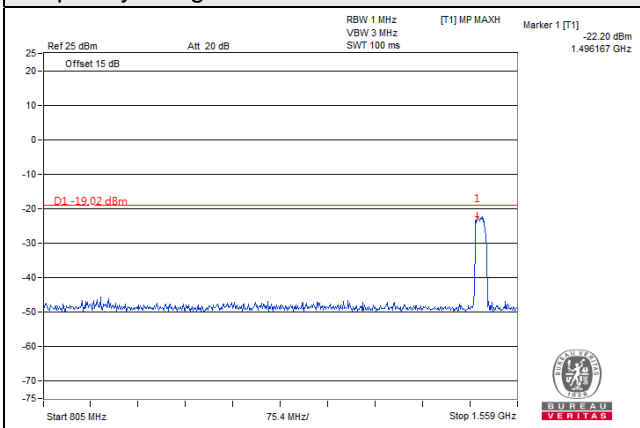

Frequency Range : 1.559GHz~1.610GHz

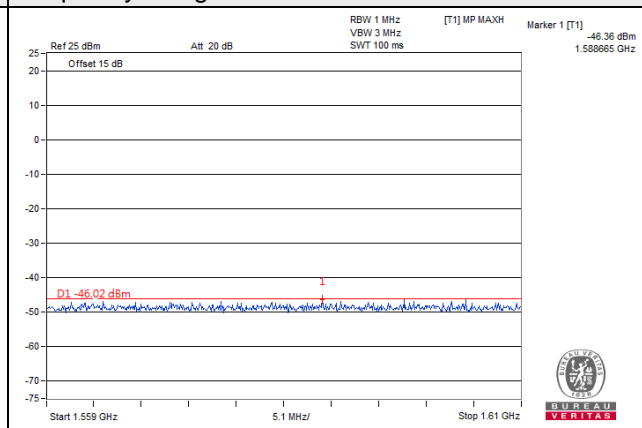

Frequency Range : 1.610GHz~9GHz

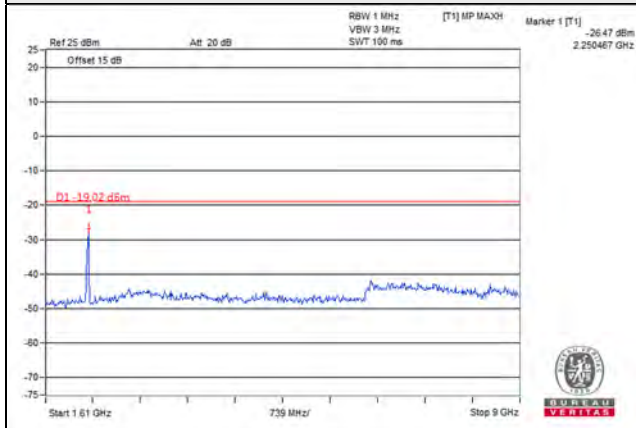

QPSK_IoT Signal at Top (Chain 0)

Channel Band width: 10MHz

Channel 5230 (751.0MHz)

Frequency Range : 9kHz~763MHz

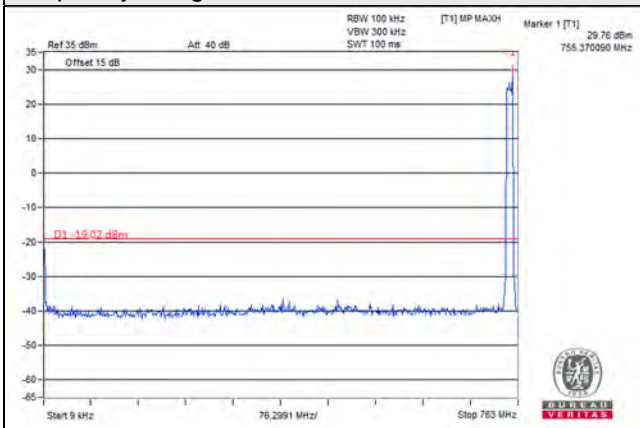

Frequency Range : 763MHz~775MHz

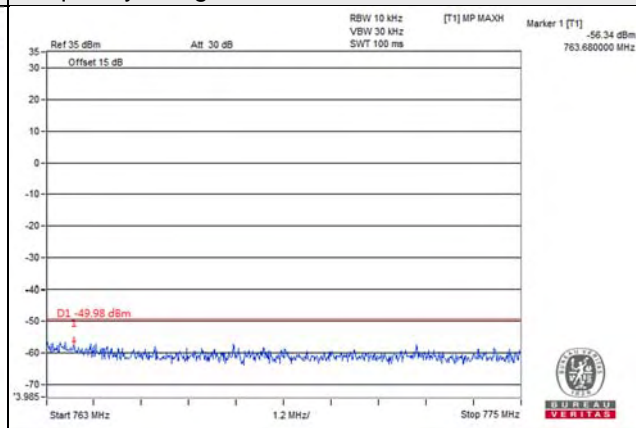

Frequency Range : 775MHz~793MHz

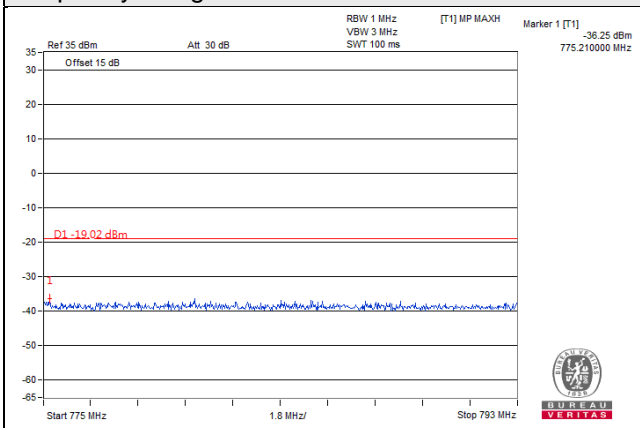

Frequency Range : 793MHz~805MHz

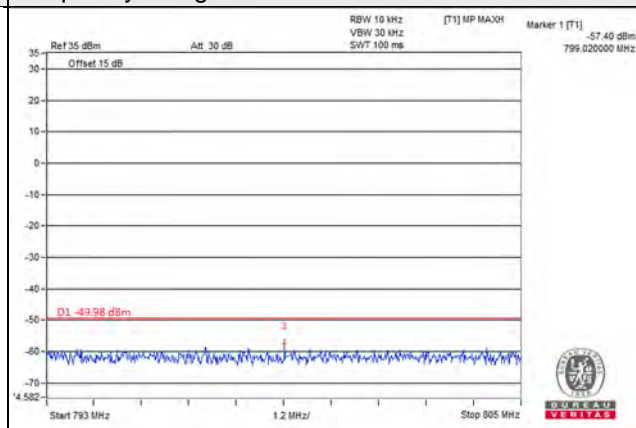

Frequency Range : 805MHz~1.559GHz

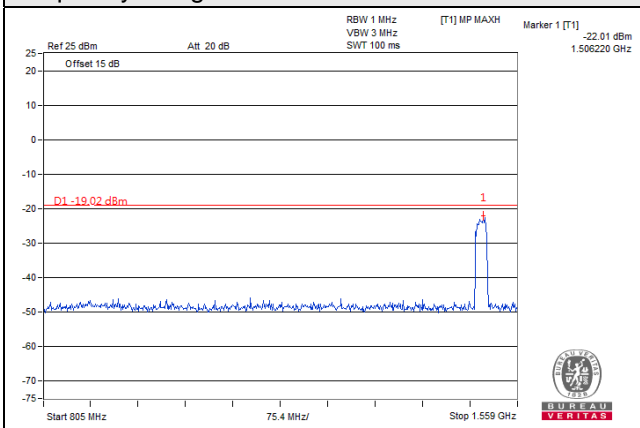

Frequency Range : 1.559GHz~1.610GHz

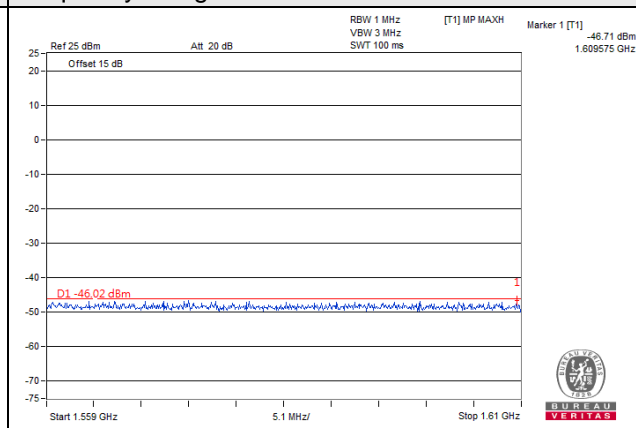

Frequency Range : 1.610GHz~9GHz

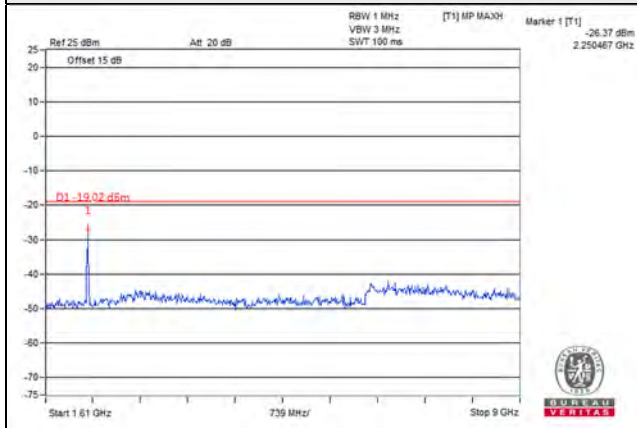

QPSK_IoT Signal at Top (Chain 1)

Channel Band width: 10MHz

Channel 5230 (751.0MHz)

Frequency Range : 9kHz~763MHz

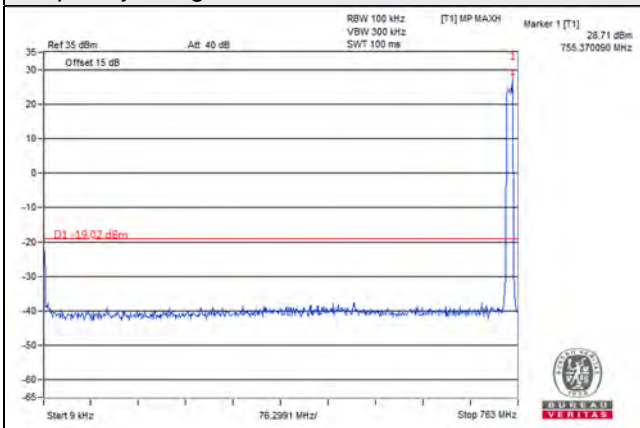

Frequency Range : 763MHz~775MHz

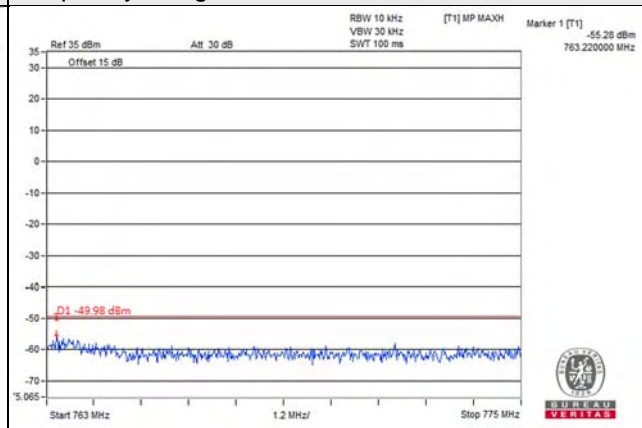

Frequency Range : 775MHz~793MHz

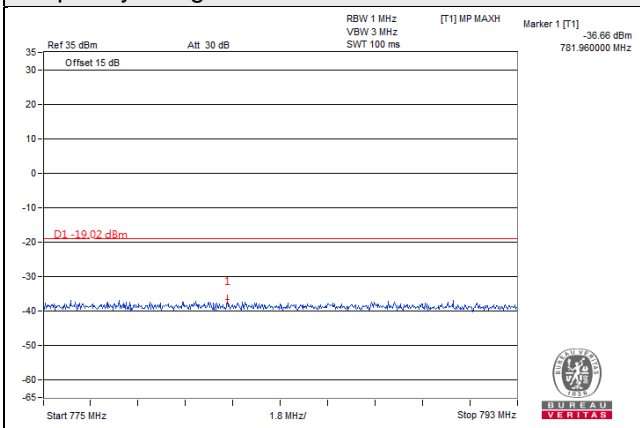

Frequency Range : 793MHz~805MHz

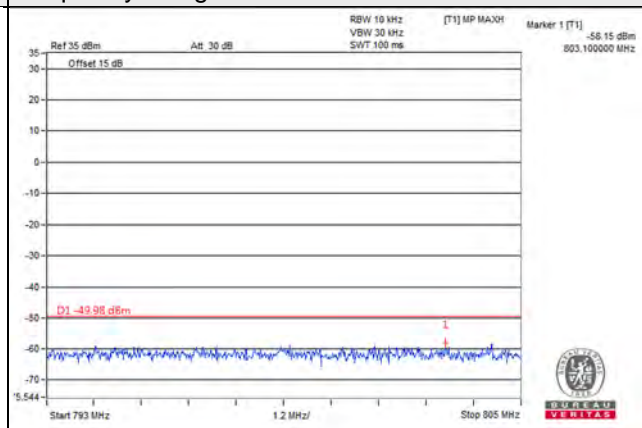

Frequency Range : 805MHz~1.559GHz

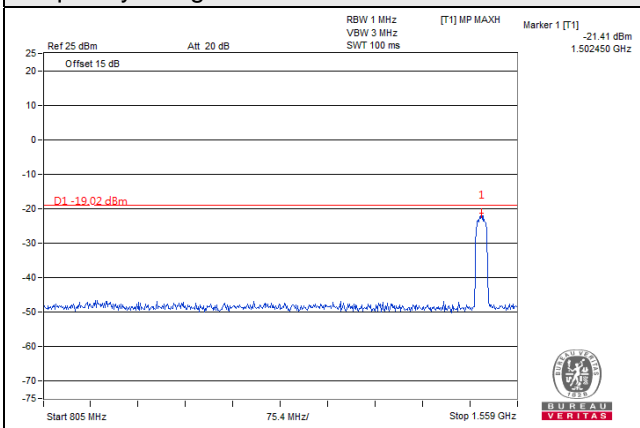

Frequency Range : 1.559GHz~1.610GHz

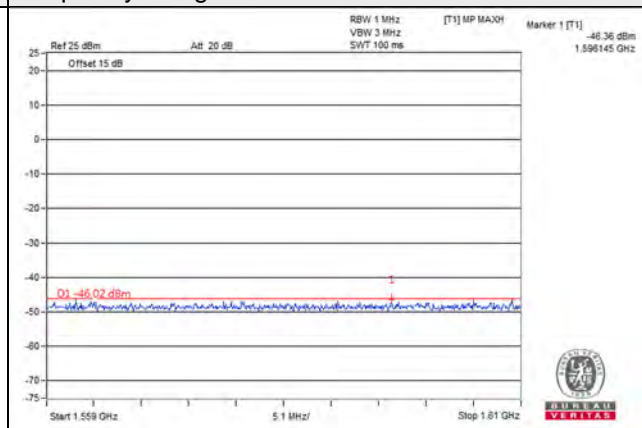

Frequency Range : 1.610GHz~9GHz

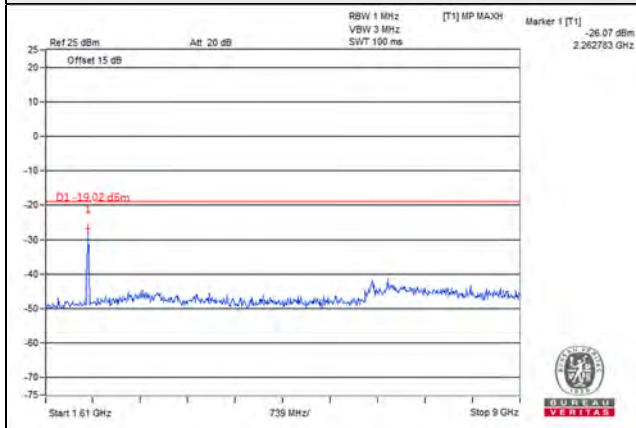

QPSK_IoT Signal at Top (Chain 2)

Channel Band width: 10MHz

Channel 5230 (751.0MHz)

Frequency Range : 9kHz~763MHz

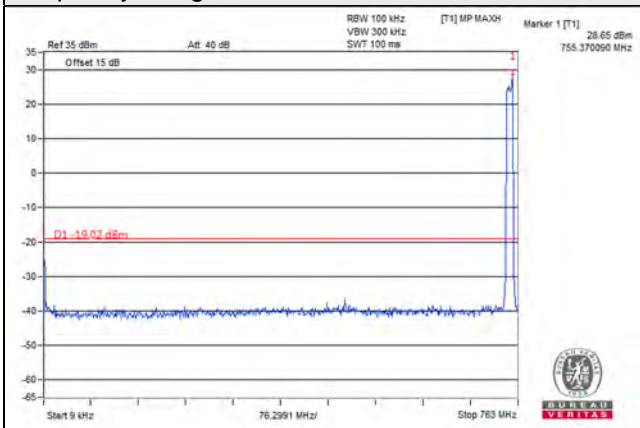

Frequency Range : 763MHz~775MHz

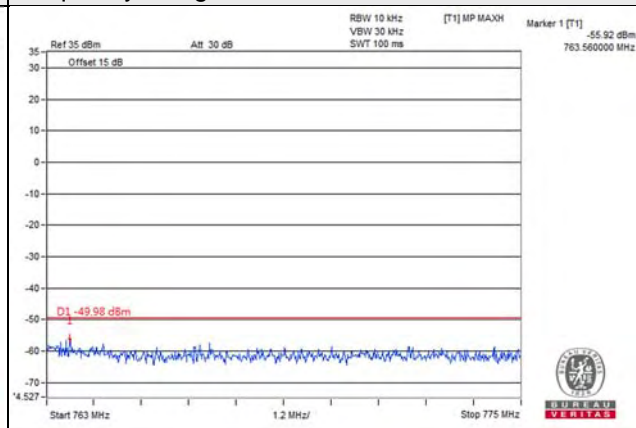

Frequency Range : 775MHz~793MHz

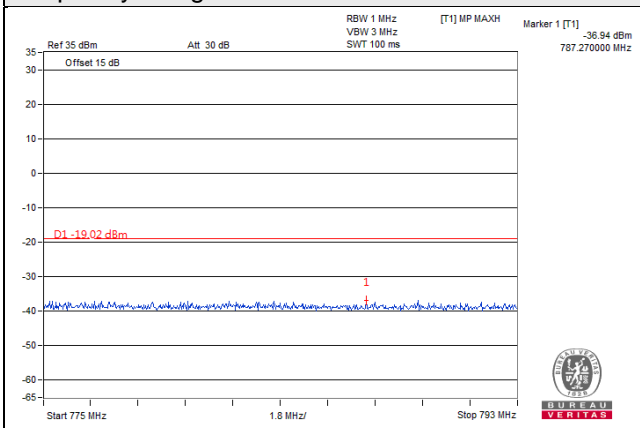

Frequency Range : 793MHz~805MHz

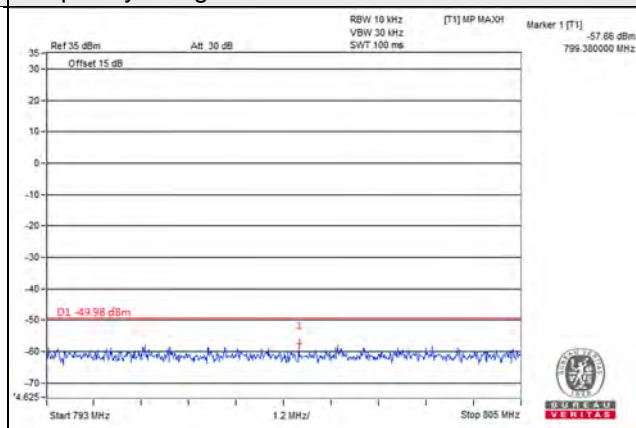

Frequency Range : 805MHz~1.559GHz

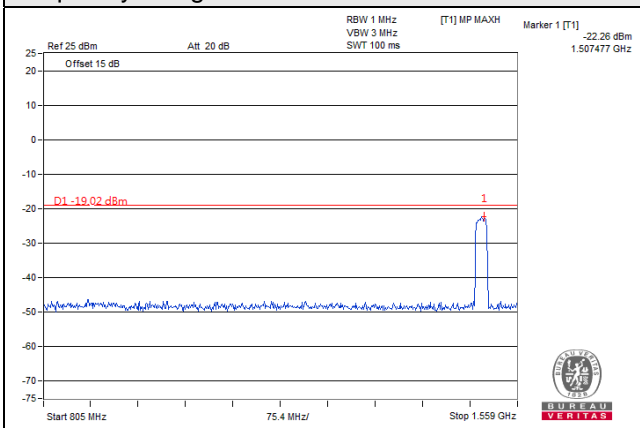

Frequency Range : 1.559GHz~1.610GHz

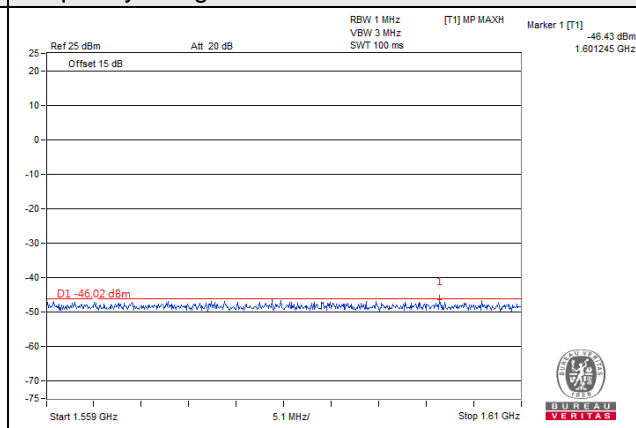

Frequency Range : 1.610GHz~9GHz

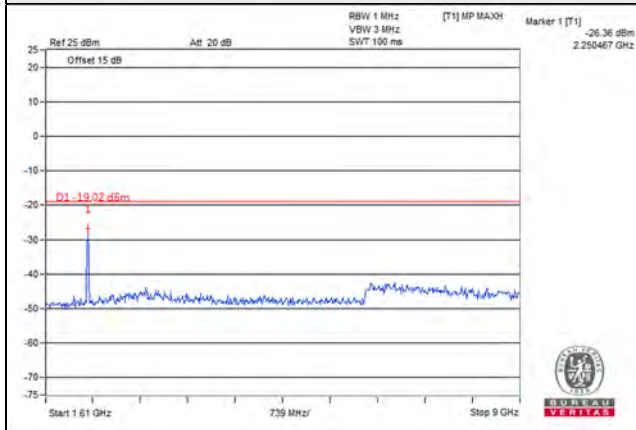

QPSK_IoT Signal at Top (Chain 3)

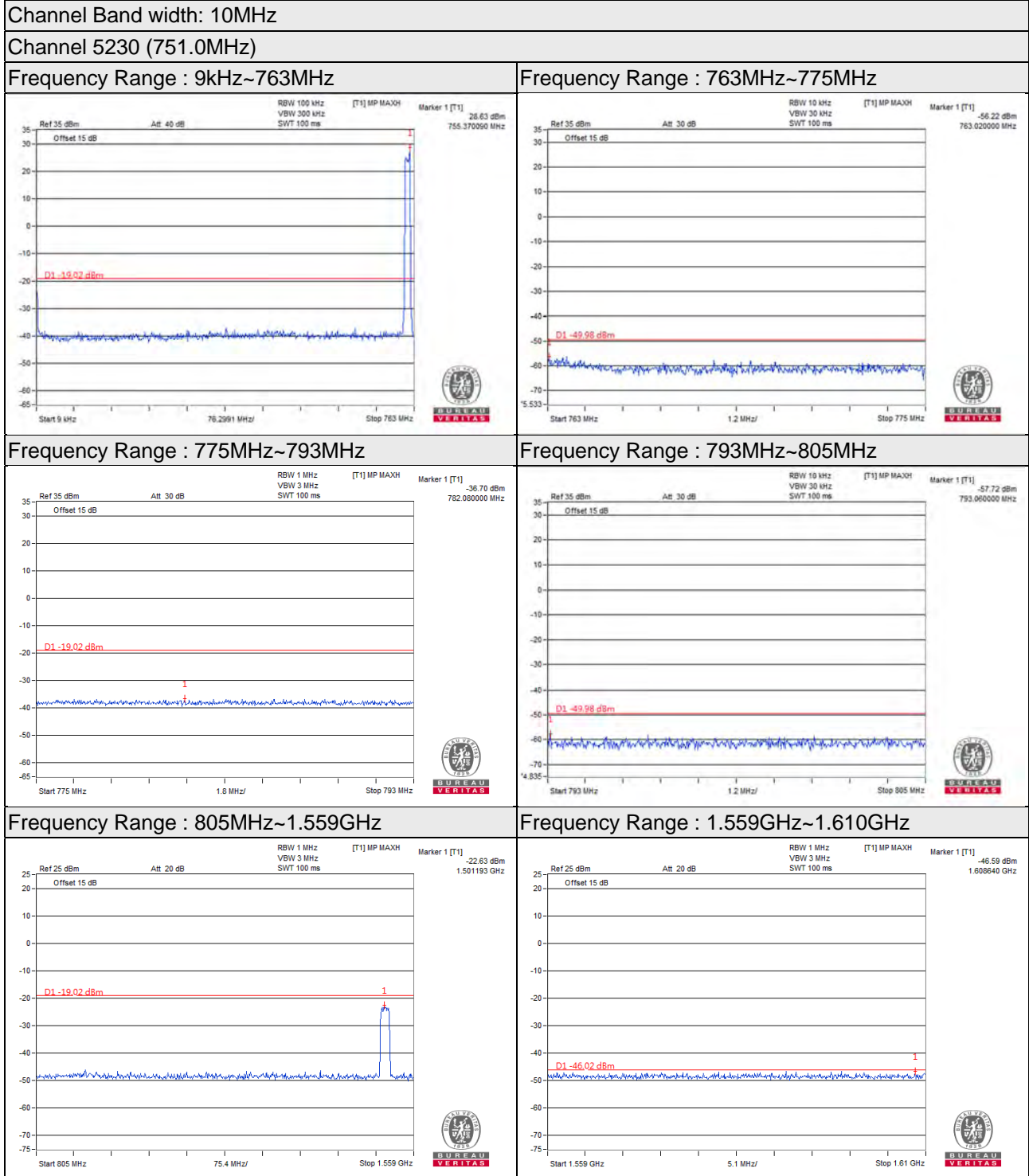

Frequency Range : 1.610GHz~9GHz

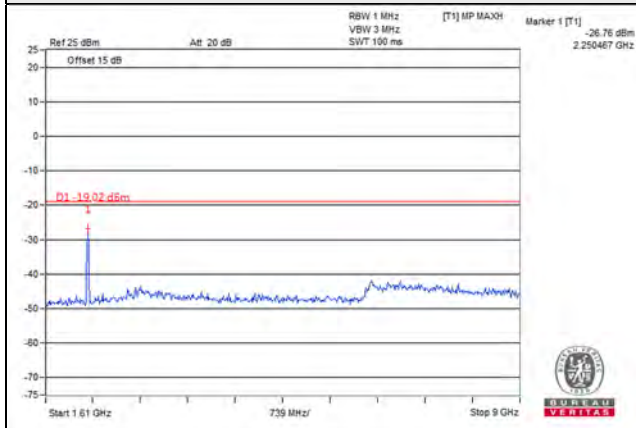

NB-IoT In-Band

Channel Bandwidth: 5MHz

QPSK_IoT Signal at Bottom (Chain 0)



Frequency Range : 1.610GHz~10GHz



Channel Band width: 5MHz

Channel 5230 (751.0MHz)

Frequency Range : 9kHz~763MHz

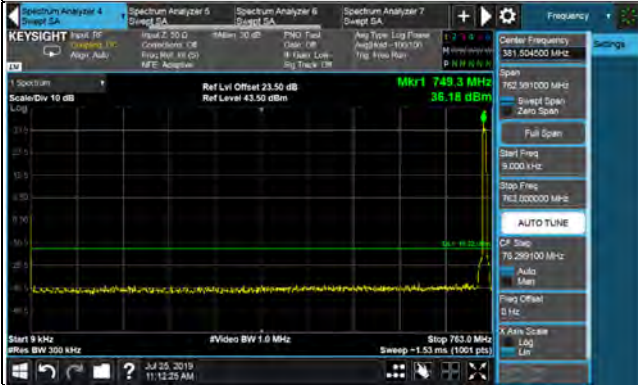

Frequency Range : 763MHz~775MHz



Frequency Range : 775MHz~793MHz

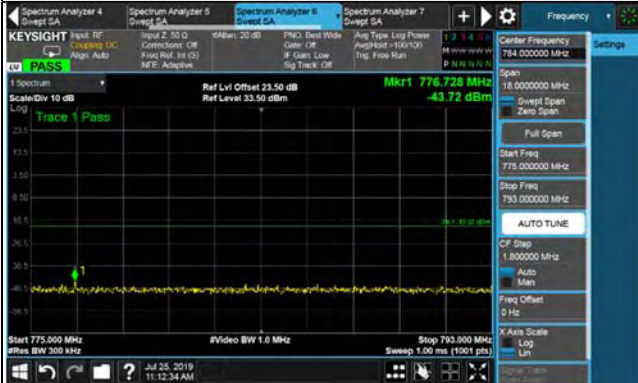

Frequency Range : 793MHz~805MHz



Frequency Range : 805MHz~1.559GHz



Frequency Range : 1.559GHz~1.610GHz



Frequency Range : 1.610GHz~10GHz



Channel Band width: 5MHz

Channel 5255 (753.5MHz)

Frequency Range : 9kHz~763MHz

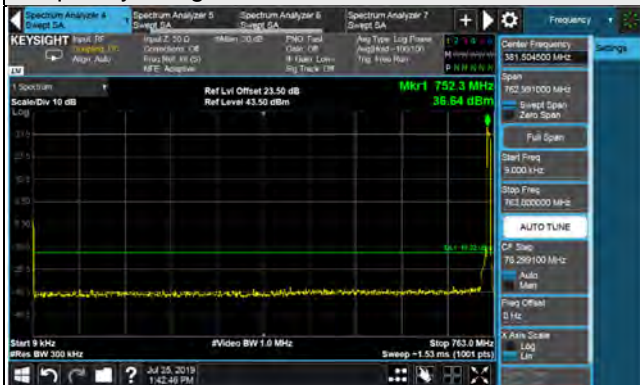

Frequency Range : 763MHz~775MHz



Frequency Range : 775MHz~793MHz



Frequency Range : 793MHz~805MHz



Frequency Range : 805MHz~1.559GHz



Frequency Range : 1.559GHz~1.610GHz



Frequency Range : 1.610GHz~10GHz



QPSK_IoT Signal at Bottom (Chain 1)

Channel Band width: 5MHz

Channel 5205 (748.5MHz)

Frequency Range : 9kHz~763MHz



Frequency Range : 763MHz~775MHz



Frequency Range : 775MHz~793MHz



Frequency Range : 793MHz~805MHz



Frequency Range : 805MHz~1.559GHz

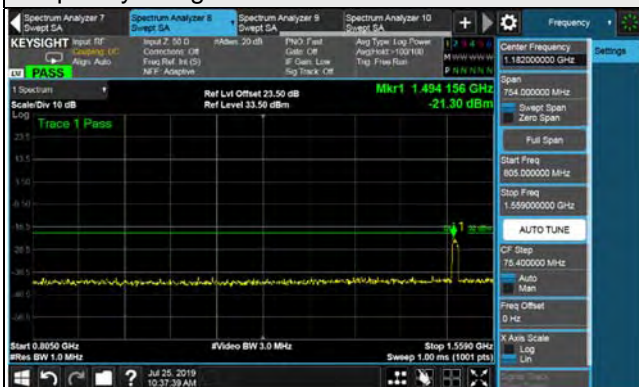

Frequency Range : 1.559GHz~1.610GHz

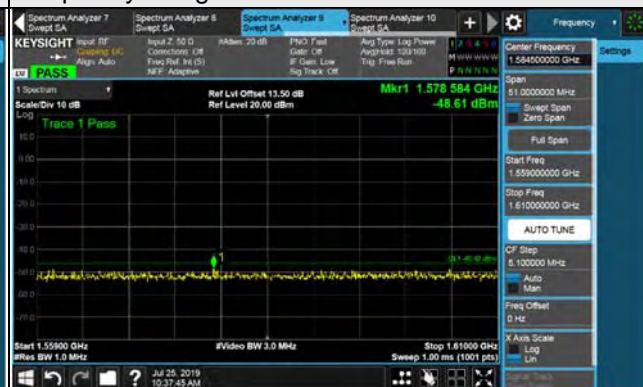

Frequency Range : 1.610GHz~10GHz

