

FCC Test Report (Part 27)

Report No.: RF180829C14

FCC ID: 2AD8UAHBB01

Test Model: AHBB

Received Date: Aug. 29, 2018

Test Date: Sep. 04 ~ Sep. 12, 2018

Issued Date: Sep. 13, 2018

Applicant: Nokia Solutions and Networks, OY

Address: 2000 W. Lucent Lane, Naperville, IL 60563, USA

Issued By: Bureau Veritas Consumer Products Services (H.K.) Ltd., Taoyuan Branch

Lab Address: No. 47-2, 14th Ling, Chia Pau Vil., Lin Kou Dist., New Taipei City, Taiwan (R.O.C.)

Test Location: No. 19, Hwa Ya 2nd Rd., Wen Hwa Vil., Kwei Shan Dist., Taoyuan City 33383, TAIWAN (R.O.C.)

**FCC Registration /
Designation Number:** 788550 / TW0003



This report is for your exclusive use. Any copying or replication of this report to or for any other person or entity, or use of our name or trademark, is permitted only with our prior written permission. This report sets forth our findings solely with respect to the test samples identified herein. The results set forth in this report are not indicative or representative of the quality or characteristics of the lot from which a test sample was taken or any similar or identical product unless specifically and expressly noted. Our report includes all of the tests requested by you and the results thereof based upon the information that you provided to us. You have 60 days from date of issuance of this report to notify us of any material error or omission caused by our negligence, provided, however, that such notice shall be in writing and shall specifically address the issue you wish to raise. A failure to raise such issue within the prescribed time shall constitute your unqualified acceptance of the completeness of this report, the tests conducted and the correctness of the report contents. Unless specific mention, the uncertainty of measurement has been explicitly taken into account to declare the compliance or non-compliance to the specification. The report must not be used by the client to claim product certification, approval, or endorsement by TAF or any government agency

Table of Contents

| | |
|---|-----------|
| Release Control Record | 4 |
| 1 Certificate of Conformity | 5 |
| 2 Summary of Test Results | 6 |
| 2.1 Measurement Uncertainty..... | 6 |
| 2.2 Test Site and Instruments..... | 7 |
| 3 General Information | 8 |
| 3.1 General Description of EUT..... | 8 |
| 3.2 Configuration of System under Test..... | 10 |
| 3.2.1 Description of Support Units..... | 10 |
| 3.3 Test Mode Applicability and Tested Channel Detail..... | 11 |
| 3.4 EUT Operating Conditions..... | 13 |
| 3.5 General Description of Applied Standards..... | 13 |
| 4 Test Types and Results | 14 |
| 4.1 Output Power Measurement..... | 14 |
| 4.1.1 Limits of Output Power Measurement..... | 14 |
| 4.1.2 Test Procedures..... | 14 |
| 4.1.3 Test Setup..... | 14 |
| 4.1.4 Test Results..... | 15 |
| 4.2 Modulation Characteristics Measurement..... | 24 |
| 4.2.1 Limits of Modulation Characteristics..... | 24 |
| 4.2.2 Test Procedure..... | 24 |
| 4.2.3 Test Setup..... | 24 |
| 4.2.4 Test Results..... | 24 |
| 4.3 Frequency Stability Measurement..... | 25 |
| 4.3.1 Limits of Frequency Stability Measurement..... | 25 |
| 4.3.2 Test Procedure..... | 25 |
| 4.3.3 Test Setup..... | 25 |
| 4.3.4 Test Results..... | 26 |
| 4.4 Emission Bandwidth Measurement..... | 28 |
| 4.4.1 Limits of Emission Bandwidth Measurement..... | 28 |
| 4.4.2 Test Procedure..... | 28 |
| 4.4.3 Test Setup..... | 28 |
| 4.4.4 Test Result..... | 29 |
| 4.5 Band Edge Measurement..... | 35 |
| 4.5.1 Limits of Band Edge Measurement..... | 35 |
| 4.5.2 Test Setup..... | 35 |
| 4.5.3 Test Procedures..... | 35 |
| 4.5.4 Test Results..... | 36 |
| 4.6 Peak to Average Ratio..... | 42 |
| 4.6.1 Limits of Peak to Average Ratio Measurement..... | 42 |
| 4.6.2 Test Setup..... | 42 |
| 4.6.3 Test Procedures..... | 42 |
| 4.6.4 Test Results..... | 43 |
| 4.7 Conducted Spurious Emissions..... | 44 |
| 4.7.1 Limits of Conducted Spurious Emissions Measurement..... | 44 |
| 4.7.2 Test Setup..... | 44 |
| 4.7.3 Test Procedure..... | 44 |
| 4.7.4 Test Results..... | 45 |
| 4.8 Radiated Emission Measurement..... | 85 |
| 4.8.1 Limits of Radiated Emission Measurement..... | 85 |
| 4.8.2 Test Procedure..... | 85 |
| 4.8.3 Deviation from Test Standard..... | 85 |
| 4.8.4 Test Setup..... | 86 |

| | |
|---|-----------|
| 4.8.5 Test Results | 87 |
| 5 Pictures of Test Arrangements..... | 97 |
| Appendix – Information on the Testing Laboratories | 98 |

Release Control Record

| Issue No. | Description | Date Issued |
|-------------|------------------|---------------|
| RF180829C14 | Original release | Sep. 13, 2018 |

1 Certificate of Conformity

Product: AirScale Micro Remote Radio Head
Brand: Nokia
Test Model: AHBB
Sample Status: Engineering sample
Applicant: Nokia Solutions and Networks, OY
Test Date: Sep. 04 ~ Sep. 12, 2018
Standards: FCC Part 27, Subpart C, F

The above equipment has been tested by **Bureau Veritas Consumer Products Services (H.K.) Ltd., Taoyuan Branch**, and found compliance with the requirement of the above standards. The test record, data evaluation & Equipment Under Test (EUT) configurations represented herein are true and accurate accounts of the measurements of the sample's RF characteristics under the conditions specified in this report.

Prepared by : Celine Chou , **Date:** Sep. 13, 2018
Celine Chou / Senior Specialist

Approved by : Bruce Chen , **Date:** Sep. 13, 2018
Bruce Chen / Project Engineer

2 Summary of Test Results

| Applied Standard: FCC Part 27 & Part 2 | | | |
|--|--|--------|---|
| FCC Clause | Test Item | Result | Remarks |
| 2.1046 27.50(b)(2) | Equivalent Isotropically Radiated Power | Pass | Meet the requirement of limit. |
| ---- | Peak To Average Ratio | Pass | Meet the requirement of limit. |
| 2.1055 27.54 | Frequency Stability Stay with the authorized bands of operation | Pass | Meet the requirement of limit. |
| 2.1049 27.53(g)(1) | Emission Bandwidth | Pass | Meet the requirement of limit. |
| 2.1051 27.53(c) | Band Edge Measurements | Pass | Meet the requirement of limit. |
| 2.1051 27.53(c) | Conducted Spurious Emissions | Pass | Meet the requirement of limit. |
| 2.1051 27.53(c) | Radiated Spurious Emissions | Pass | Meet the requirement of limit. Minimum passing margin is -37.50dB at 1497.00MHz. |

2.1 Measurement Uncertainty

Where relevant, the following measurement uncertainty levels have been estimated for tests performed on the EUT as specified in CISPR 16-4-2:

| Measurement | Frequency | Expanded Uncertainty (k=2) (±) |
|--------------------------------|-----------------|--------------------------------|
| Radiated Emissions up to 1 GHz | 30MHz ~ 200MHz | 3.59 dB |
| | 200MHz ~1000MHz | 3.60 dB |
| Radiated Emissions above 1 GHz | 1GHz ~ 18GHz | 2.29 dB |
| | 18GHz ~ 40GHz | 2.29 dB |

2.2 Test Site and Instruments

| Description & Manufacturer | Model No. | Serial No. | Cal. Date | Cal. Due |
|---|------------------------------------|---------------------------------|---------------|---------------|
| Test Receiver KEYSIGHT | N9038A | MY55420137 | Apr. 11, 2018 | Apr. 10, 2019 |
| Spectrum Analyzer ROHDE & SCHWARZ | FSP40 | 100269 | May 29, 2018 | May 28, 2019 |
| BILOG Antenna SCHWARZBECK | VULB9168 | 9168-148 | Dec. 11, 2017 | Dec. 10, 2018 |
| HORN Antenna SCHWARZBECK | BBHA 9120 D | 9120D-1169 | Dec. 12, 2017 | Dec. 11, 2018 |
| HORN Antenna SCHWARZBECK | BBHA 9170 | BBHA9170241 | Dec. 01, 2017 | Nov. 30, 2018 |
| Loop Antenna TESEQ | HLA 6121 | 45745 | Jun. 14, 2018 | Jun. 13, 2019 |
| Preamplifier Agilent (Below 1GHz) | 8447D | 2944A10638 | Aug. 08, 2018 | Aug. 07, 2019 |
| Preamplifier Agilent (Above 1GHz) | 8449B | 3008A01638 | Feb. 22, 2018 | Feb. 21, 2019 |
| RF signal cable HUBER+SUHNER&EMCI | SUCOFLEX 104 & EMC104-SM-SM8000 | CABLE-CH9-02 (248780+171006) | Jan. 15, 2018 | Jan. 14, 2019 |
| RF signal cable HUBER+SUHNER | SUCOFLEX 104 | CABLE-CH9-(250795/4) | Aug. 08, 2018 | Aug. 07, 2019 |
| RF signal cable Woken | 8D-FB | Cable-CH9-01 | Jul. 31, 2018 | Jul. 30, 2019 |
| Software BV ADT | ADT_Radiated_ V7.6.15.9.5 | NA | NA | NA |
| Antenna Tower EMCO | 2070/2080 | 512.835.4684 | NA | NA |
| Turn Table EMCO | 2087-2.03 | NA | NA | NA |
| Antenna Tower & Turn BV ADT | AT100 | AT93021705 | NA | NA |
| Turn Table BV ADT | TT100 | TT93021705 | NA | NA |
| Turn Table Controller BV ADT | SC100 | SC93021705 | NA | NA |
| Boresight Antenna Fixture | FBA-01 | FBA-SIP01 | NA | NA |
| High Speed Peak Power Meter | ML2495A | 1232003 | Dec. 29, 2017 | Dec. 28, 2018 |
| Power Sensor | MA2411B | 1207333 | Dec. 28, 2017 | Dec. 27, 2018 |
| WIT Standard Temperature And Humidity Chamber | TH-4S-C | W981030 | Jun. 04, 2018 | Jun. 03, 2019 |
| Mini-Circuits Power Splitter | ZN2PD-9G | NA | Jun. 21, 2018 | Jun. 20, 2019 |
| JFW 20dB attenuation | 50HF-020-SMA | NA | NA | NA |

- Note:
1. The calibration interval of the above test instruments is 12 months and the calibrations are traceable to NML/ROC and NIST/USA.
 2. The test was performed in HwaYa Chamber 9.
 3. The FCC Designation Number is TW0003. The number will be varied with the Lab location and scope as attached.
 4. The IC Site Registration No. is IC 7450F-9.

3 General Information

3.1 General Description of EUT

| | | | |
|---------------------|---|-------------------------------|-------------------------|
| Product | AirScale Micro Remote Radio Head | | |
| Brand | Nokia | | |
| Test Model | AHBB | | |
| Status of EUT | Engineering sample | | |
| Power Supply Rating | I/P: 100-240Vac, 50-60Hz, 3A MAX O/P: -54Vdc, 3A MAX | | |
| Modulation Type | QPSK, 16QAM, 64QAM, 256QAM | | |
| Operating Frequency | LTE Band 13 | Channel Bandwidth 5MHz | 748.5MHz ~ 753.5MHz |
| | | Channel Bandwidth 10MHz | 751.0MHz |
| | | Channel Bandwidth 5MHz + 5MHz | 751.0MHz |
| Max. ERP Power | LTE Band 13 | Channel Bandwidth 5MHz | 315500.462mW (54.99dBm) |
| | | Channel Bandwidth 10MHz | 323593.657mW (55.10dBm) |
| | | Channel Bandwidth 5MHz + 5MHz | 319153.786mW (55.04dBm) |
| Emission Designator | LTE Band 13 | Channel Bandwidth 5MHz | QPSK: 4M50G7D |
| | | | 16QAM: 4M48D7W |
| | | | 64QAM: 4M48D7W |
| | | | 256QAM: 4M48D7W |
| | | Channel Bandwidth 10MHz | QPSK: 9M00G7D |
| | | | 16QAM: 9M00D7W |
| | | | 64QAM: 8M96D7W |
| | | | 256QAM: 9M00D7W |
| | | Channel Bandwidth 5MHz + 5MHz | QPSK: 9M43G7D |
| | | | 16QAM: 9M46D7W |
| | | | 64QAM: 9M46D7W |
| | | | 256QAM: 9M46D7W |
| Antenna Gain | 8dBi | | |
| S/N | 474042A | | |
| HW Version | X21 | | |
| SW Version | FDD-LTE 18A | | |
| Accessory Device | Refer to Note as below | | |
| Cable Supplied | NA | | |

Note:

- The EUT incorporates a MIMO function. Physically, the EUT provides 4 completed transmitters and 4 receivers.

| Modulation Mode | TX Function |
|-------------------------------|-------------|
| QPSK 、 16QAM 、 64QAM 、 256QAM | 1TX |
| QPSK 、 16QAM 、 64QAM 、 256QAM | 2TX |
| QPSK 、 16QAM 、 64QAM 、 256QAM | 3TX |
| QPSK 、 16QAM 、 64QAM 、 256QAM | 4TX |

2. The EUT contains following accessory devices.

| AC PSU (Optional) | |
|-------------------|-----------------------------|
| Brand | Nokia |
| Model | APAB |
| Sales Item | 474130A.102 |
| S/N | U7174800066 |
| Remark | SUPLET/S818A160-220S54W |
| Input Power | 100-240Vac, 50-60Hz, 3A MAX |
| Output Power | -54Vdc, 3A MAX |

3. The antenna gain for reference only, the test was done with 50ohm terminator on antenna port.

3.2 Configuration of System under Test

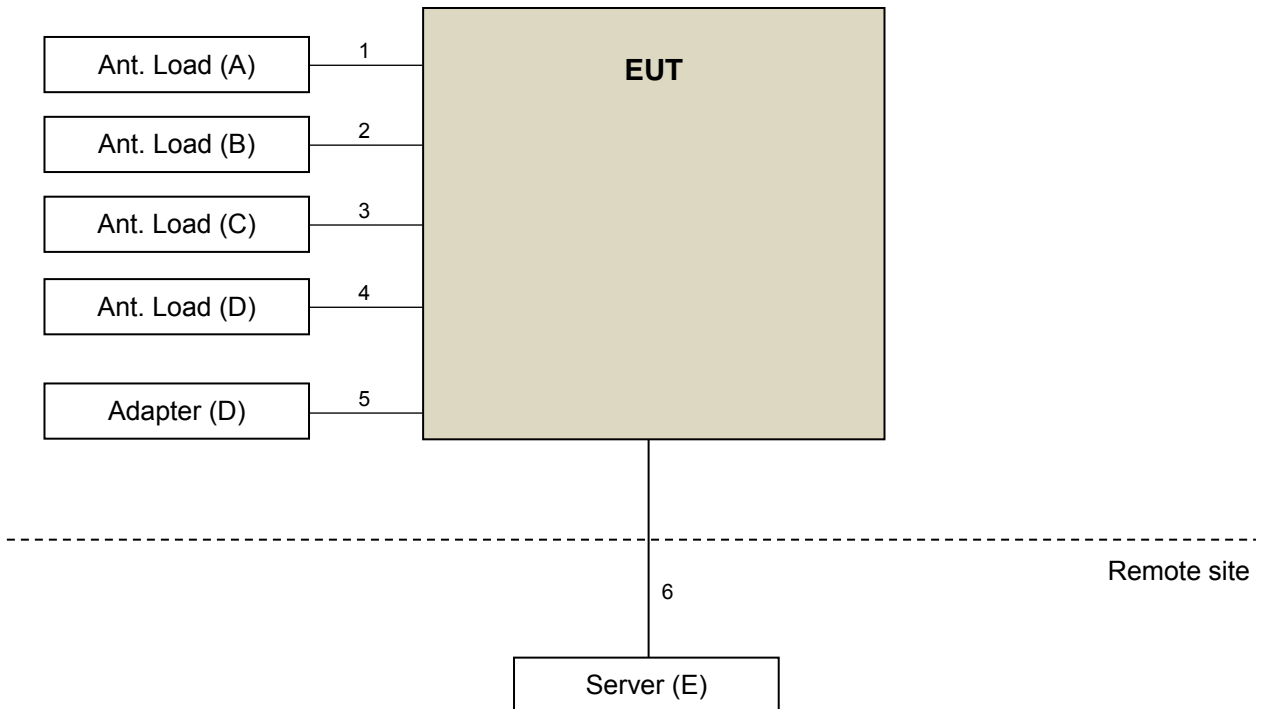

3.2.1 Description of Support Units

The EUT has been tested as an independent unit together with other necessary accessories or support units. The following support units or accessories were used to form a representative test configuration during the tests.

| ID | Product | Brand | Model No. | Serial No. | FCC ID | Remarks |
|----|-----------|-------|-----------|------------|--------|--------------------------|
| A. | Ant. Load | NA | NA | NA | NA | Provided by manufacturer |
| B. | Ant. Load | NA | NA | NA | NA | Provided by manufacturer |
| C. | Ant. Load | NA | NA | NA | NA | Provided by manufacturer |
| D. | Ant. Load | NA | NA | NA | NA | Provided by manufacturer |
| E. | Adapter | NA | NA | NA | NA | Provided by manufacturer |
| F. | Server | NA | NA | NA | NA | Provided by manufacturer |

Note:

1. All power cords of the above support units are non-shielded (1.8m).
2. Item E acted as a communication partner to transfer data.

| ID | Descriptions | Qty. | Length (m) | Shielding (Yes/No) | Cores (Qty.) | Remarks |
|----|--------------|------|------------|--------------------|--------------|--------------------------|
| 1. | Ant. Cable | 1 | 1 | Y | 0 | - |
| 2. | Ant. Cable | 1 | 1 | Y | 0 | - |
| 3. | Ant. Cable | 1 | 1 | Y | 0 | - |
| 4. | Ant. Cable | 1 | 1 | Y | 0 | - |
| 5. | DC Cable | 1 | 0.55 | N | 0 | Provided by manufacturer |
| 6. | Fiber Cable | 2 | 10 | N | 0 | - |

3.3 Test Mode Applicability and Tested Channel Detail

Pre-Scan has been conducted to determine the worst-case mode from all possible combinations between available modulations, data rates, XYZ axis and antenna ports. The worst case was found when positioned on X-plane. Following channel(s) was (were) selected for the final test as listed below:

| EUT Configure Mode | Test item | Available channel | Tested channel | Channel Bandwidth | Modulation | Mode |
|--------------------|------------------------------|-------------------|---|-------------------|----------------------------------|---------|
| - | ERP | 5205 to 5255 | 5205 (748.5MHz), 5230 (751.0MHz), 5255 (753.5MHz) | 5MHz | QPSK / 16QAM / 64QAM / 256QAM | Full RB |
| | | 5230 | 5230 (751.0MHz) | 10MHz | QPSK / 16QAM / 64QAM / 256QAM | Full RB |
| - | Modulation Characteristics | 5230 | 5230 (751.0MHz) | 10MHz | QPSK / 16QAM / 64QAM / 256QAM | Full RB |
| - | Frequency Stability | 5205 to 5255 | 5230 (751.0MHz), | 5MHz | QPSK | Full RB |
| | | 5230 | 5230 (751.0MHz) | 10MHz | QPSK | Full RB |
| - | Emission Bandwidth | 5205 to 5255 | 5205 (748.5MHz), 5230 (751.0MHz), 5255 (753.5MHz) | 5MHz | QPSK / 16QAM / 64QAM / 256QAM | Full RB |
| | | 5230 | 5230 (751.0MHz) | 10MHz | QPSK / 16QAM / 64QAM / 256QAM | Full RB |
| - | Band Edge | 5205 to 5255 | 5205 (748.5MHz), 5255 (753.5MHz) | 5MHz | QPSK | Full RB |
| | | 5230 | 5230 (751.0MHz) | 10MHz | QPSK | Full RB |
| - | Peak to Average Ratio | 5205 to 5255 | 5205 (748.5MHz), 5230 (751.0MHz), 5255 (753.5MHz) | 5MHz | QPSK / 16QAM / 64QAM / 256QAM | Full RB |
| | | 5230 | 5230 (751.0MHz) | 10MHz | QPSK / 16QAM / 64QAM / 256QAM | Full RB |
| - | Conducted Emission | 5205 to 5255 | 5205 (748.5MHz), 5230 (751.0MHz), 5255 (753.5MHz) | 5MHz | QPSK | Full RB |
| | | 5230 | 5230 (751.0MHz) | 10MHz | QPSK | Full RB |
| - | Radiated Emission below 1GHz | 5205 to 5255 | 23130(711.0MHz) | 5MHz | QPSK | Full RB |
| | | 5230 | 5230 (751.0MHz) | 10MHz | QPSK | Full RB |
| - | Radiated Emission above 1GHz | 5205 to 5255 | 5205 (748.5MHz), 5230 (751.0MHz), 5255 (753.5MHz) | 5MHz | QPSK | Full RB |
| | | 5230 | 5230 (751.0MHz) | 10MHz | QPSK | Full RB |

Note: The conducted output power for QPSK, 16QAM, 64QAM and 256QAM measured value of QPSK is higher than 16QAM, 64QAM and 256QAM mode. Therefore, only Modulation Characteristics, Emission Bandwidth and Peak to average ratio items had been tested under QPSK, 16QAM, 64QAM and 256QAM modes, the other test items were performed under QPSK mode only.

2-Carriers Mode

| EUT Configure Mode | Test item | Available channel | Tested channel | Channel Bandwidth | Modulation | Mode |
|--------------------|------------------------------|-------------------|-----------------|-------------------|-------------------------------|---------|
| - | ERP | 5230 | 5230 (751.0MHz) | 5MHz + 5MHz | QPSK / 16QAM / 64QAM / 256QAM | Full RB |
| - | Emission Bandwidth | 5230 | 5230 (751.0MHz) | 5MHz + 5MHz | QPSK / 16QAM / 64QAM / 256QAM | Full RB |
| - | Band Edge | 5230 | 5230 (751.0MHz) | 5MHz + 5MHz | QPSK | Full RB |
| - | Conducted Emission | 5230 | 5230 (751.0MHz) | 5MHz + 5MHz | QPSK | Full RB |
| - | Radiated Emission below 1GHz | 5230 | 5230 (751.0MHz) | 5MHz + 5MHz | QPSK | Full RB |
| - | Radiated Emission above 1GHz | 5230 | 5230 (751.0MHz) | 5MHz + 5MHz | QPSK | Full RB |

Note: The conducted output power for QPSK, 16QAM, 64QAM and 256QAM measured value of QPSK is higher than 16QAM, 64QAM and 256QAM mode. Therefore, only Emission Bandwidth test item had been tested under QPSK, 16QAM, 64QAM and 256QAM modes, the other test items were performed under QPSK mode only.

Test Condition:

| Test Item | Environmental Conditions | Input Power | Tested By |
|----------------------------|--------------------------|--------------|------------|
| ERP | 24deg. C, 64%RH | 120Vac, 60Hz | James Yang |
| Modulation characteristics | 24deg. C, 64%RH | 120Vac, 60Hz | James Yang |
| Frequency Stability | 24deg. C, 64%RH | 120Vac, 60Hz | James Yang |
| Emission Bandwidth | 24deg. C, 64%RH | 120Vac, 60Hz | James Yang |
| Band Edge | 24deg. C, 64%RH | 120Vac, 60Hz | James Yang |
| Peak To Average Ratio | 24deg. C, 64%RH | 120Vac, 60Hz | James Yang |
| Conducted Emission | 24deg. C, 64%RH | 120Vac, 60Hz | James Yang |
| Radiated Emission | 25deg. C, 65%RH | 120Vac, 60Hz | Han Wu |

3.4 EUT Operating Conditions

The EUT makes a call to the communication simulator. The communication simulator station system controlled a EUT to export maximum output power under transmission mode and specific channel frequency

3.5 General Description of Applied Standards

The EUT is a RF Product. According to the specifications of the manufacturer, it must comply with the requirements of the following standards:

FCC 47 CFR Part 2

FCC 47 CFR Part 27

KDB 971168 D01 Power Meas License Digital Systems v03r01

KDB 662911 D01 Multiple Transmitter Output v02r01

ANSI/TIA/EIA-603-E 2016

ANSI 63.26-2015

Note: All test items have been performed and recorded as per the above standards.

4 Test Types and Results

4.1 Output Power Measurement

4.1.1 Limits of Output Power Measurement

Fixed and base stations transmitting a signal in the 746-757 MHz and 776-787 MHz bands with an emission bandwidth of 1 MHz or less must not exceed an ERP of 1000 watts and an antenna height of 305 m HAAT, except that antenna heights greater than 305 m HAAT are permitted if power levels are reduced below 1000 watts ERP in accordance with Table 1 of this section.

4.1.2 Test Procedures

The EUT was set up for the maximum power with LTE link data modulation and link up with simulator. Set the EUT to transmit under low, middle and high channel and record the power level shown on simulator.

4.1.3 Test Setup



4.1.4 Test Results

Conducted Output Power (dBm)

1TX

| Band / BW | Ant | QPSK | | | 16QAM | | | 64QAM | | | 256QAM | | |
|-----------|---------|-----------|---------|-----------|-----------|---------|-----------|-----------|---------|-----------|-----------|---------|-----------|
| | | Low CH | Mid CH | High CH | Low CH | Mid CH | High CH | Low CH | Mid CH | High CH | Low CH | Mid CH | High CH |
| | | 5205 | 5230 | 5255 | 5205 | 5230 | 5255 | 5205 | 5230 | 5255 | 5205 | 5230 | 5255 |
| | | 748.5 MHz | 751 MHz | 753.5 MHz | 748.5 MHz | 751 MHz | 753.5 MHz | 748.5 MHz | 751 MHz | 753.5 MHz | 748.5 MHz | 751 MHz | 753.5 MHz |
| 13 / 5M | Chain 0 | 37.07 | 36.99 | 36.98 | 37.01 | 37.08 | 37.09 | 36.97 | 36.92 | 36.97 | 36.95 | 36.89 | 36.89 |
| | Chain 1 | 37.15 | 37.09 | 37.02 | 37.13 | 37.05 | 37.12 | 36.92 | 36.88 | 36.95 | 36.99 | 36.88 | 36.87 |
| | Chain 2 | 37.07 | 37.08 | 37.02 | 37.05 | 37.06 | 37.10 | 36.95 | 37.00 | 36.99 | 36.92 | 36.95 | 36.91 |
| | Chain 3 | 36.99 | 37.04 | 37.01 | 37.08 | 37.02 | 37.09 | 36.89 | 36.97 | 36.92 | 36.98 | 36.97 | 36.92 |

| Band / BW | Ant | QPSK | 16QAM | 64QAM | 256QAM |
|-----------|---------|---------|---------|---------|---------|
| | | Mid CH | Mid CH | Mid CH | Mid CH |
| | | 5230 | 5230 | 5230 | 5230 |
| | | 751 MHz | 751 MHz | 751 MHz | 751 MHz |
| 13 / 10M | Chain 0 | 37.10 | 36.99 | 36.92 | 36.87 |
| | Chain 1 | 37.28 | 37.08 | 36.98 | 36.95 |
| | Chain 2 | 37.23 | 37.01 | 36.89 | 36.92 |
| | Chain 3 | 37.23 | 37.03 | 36.92 | 36.97 |

| Band / BW | Ant | QPSK | 16QAM | 64QAM | 256QAM |
|--------------------|---------|---------|---------|---------|---------|
| | | Mid CH | Mid CH | Mid CH | Mid CH |
| | | 5230 | 5230 | 5230 | 5230 |
| | | 751 MHz | 751 MHz | 751 MHz | 751 MHz |
| 2-Carriers / 5M+5M | Chain 0 | 37.04 | 37.01 | 36.88 | 36.85 |
| | Chain 1 | 37.26 | 37.18 | 36.91 | 36.89 |
| | Chain 2 | 37.16 | 37.12 | 36.75 | 36.65 |
| | Chain 3 | 37.14 | 37.09 | 36.72 | 36.56 |

2TX

| Band / BW | Ant | QPSK | | | 16QAM | | | 64QAM | | | 256QAM | | |
|-----------|-------------|-----------|---------|-----------|-----------|---------|-----------|-----------|---------|-----------|-----------|---------|-----------|
| | | Low CH | Mid CH | High CH | Low CH | Mid CH | High CH | Low CH | Mid CH | High CH | Low CH | Mid CH | High CH |
| | | 5205 | 5230 | 5255 | 5205 | 5230 | 5255 | 5205 | 5230 | 5255 | 5205 | 5230 | 5255 |
| | | 748.5 MHz | 751 MHz | 753.5 MHz | 748.5 MHz | 751 MHz | 753.5 MHz | 748.5 MHz | 751 MHz | 753.5 MHz | 748.5 MHz | 751 MHz | 753.5 MHz |
| 13 / 5M | Chain 1 | 37.15 | 37.09 | 37.02 | 37.13 | 37.05 | 37.12 | 36.92 | 36.88 | 36.95 | 36.99 | 36.88 | 36.87 |
| | Chain 2 | 37.07 | 37.08 | 37.02 | 37.05 | 37.06 | 37.10 | 36.95 | 37.00 | 36.99 | 36.92 | 36.95 | 36.91 |
| | Total Power | 40.12 | 40.10 | 40.03 | 40.10 | 40.07 | 40.12 | 39.95 | 39.95 | 39.98 | 39.97 | 39.93 | 39.90 |

| Band / BW | Ant | QPSK | 16QAM | 64QAM | 256QAM |
|-----------|-------------|---------|---------|---------|---------|
| | | Mid CH | Mid CH | Mid CH | Mid CH |
| | | 5230 | 5230 | 5230 | 5230 |
| | | 751 MHz | 751 MHz | 751 MHz | 751 MHz |
| 13 / 10M | Chain 1 | 37.28 | 37.08 | 36.98 | 36.95 |
| | Chain 2 | 37.23 | 37.01 | 36.89 | 36.92 |
| | Total Power | 40.27 | 40.06 | 39.95 | 39.95 |

| Band / BW | Ant | QPSK | 16QAM | 64QAM | 256QAM |
|--------------------|-------------|---------|---------|---------|---------|
| | | Mid CH | Mid CH | Mid CH | Mid CH |
| | | 5230 | 5230 | 5230 | 5230 |
| | | 751 MHz | 751 MHz | 751 MHz | 751 MHz |
| 2-Carriers / 5M+5M | Chain 1 | 37.26 | 37.18 | 36.91 | 36.89 |
| | Chain 2 | 37.16 | 37.12 | 36.75 | 36.65 |
| | Total Power | 40.22 | 40.16 | 39.84 | 39.78 |

Note: The 2TX MIMO power was select worst 2 chain total calculation

3TX

| Band / BW | Ant | QPSK | | | 16QAM | | | 64QAM | | | 256QAM | | |
|-----------|-------------|-----------|---------|-----------|-----------|---------|-----------|-----------|---------|-----------|-----------|---------|-----------|
| | | Low CH | Mid CH | High CH | Low CH | Mid CH | High CH | Low CH | Mid CH | High CH | Low CH | Mid CH | High CH |
| | | 5205 | 5230 | 5255 | 5205 | 5230 | 5255 | 5205 | 5230 | 5255 | 5205 | 5230 | 5255 |
| | | 748.5 MHz | 751 MHz | 753.5 MHz | 748.5 MHz | 751 MHz | 753.5 MHz | 748.5 MHz | 751 MHz | 753.5 MHz | 748.5 MHz | 751 MHz | 753.5 MHz |
| 13 / 5M | Chain 1 | 37.15 | 37.09 | 37.02 | 37.13 | 37.05 | 37.12 | 36.92 | 36.88 | 36.95 | 36.99 | 36.88 | 36.87 |
| | Chain 2 | 37.07 | 37.08 | 37.02 | 37.05 | 37.06 | 37.10 | 36.95 | 37.00 | 36.99 | 36.92 | 36.95 | 36.91 |
| | Chain 3 | 36.99 | 37.04 | 37.01 | 37.08 | 37.02 | 37.09 | 36.89 | 36.97 | 36.92 | 36.98 | 36.97 | 36.92 |
| | Total Power | 41.84 | 41.84 | 41.79 | 41.86 | 41.81 | 41.87 | 41.69 | 41.72 | 41.72 | 41.73 | 41.70 | 41.67 |

| Band / BW | Ant | QPSK | 16QAM | 64QAM | 256QAM |
|-----------|-------------|---------|---------|---------|---------|
| | | Mid CH | Mid CH | Mid CH | Mid CH |
| | | 5230 | 5230 | 5230 | 5230 |
| | | 751 MHz | 751 MHz | 751 MHz | 751 MHz |
| 13 / 10M | Chain 1 | 37.28 | 37.08 | 36.98 | 36.95 |
| | Chain 2 | 37.23 | 37.01 | 36.89 | 36.92 |
| | Chain 3 | 37.23 | 37.03 | 36.92 | 36.97 |
| | Total Power | 42.02 | 41.81 | 41.70 | 41.72 |

| Band / BW | Ant | QPSK | 16QAM | 64QAM | 256QAM |
|--------------------|-------------|---------|---------|---------|---------|
| | | Mid CH | Mid CH | Mid CH | Mid CH |
| | | 5230 | 5230 | 5230 | 5230 |
| | | 751 MHz | 751 MHz | 751 MHz | 751 MHz |
| 2-Carriers / 5M+5M | Chain 1 | 37.26 | 37.18 | 36.91 | 36.89 |
| | Chain 2 | 37.16 | 37.12 | 36.75 | 36.65 |
| | Chain 3 | 37.14 | 37.09 | 36.72 | 36.56 |
| | Total Power | 41.96 | 41.90 | 41.57 | 41.47 |

Note: The 3TX MIMO power was select worst 3 chain total calculation

4TX

| Band / BW | Ant | QPSK | | | 16QAM | | | 64QAM | | | 256QAM | | |
|-----------|-------------|-----------|---------|-----------|-----------|---------|-----------|-----------|---------|-----------|-----------|---------|-----------|
| | | Low CH | Mid CH | High CH | Low CH | Mid CH | High CH | Low CH | Mid CH | High CH | Low CH | Mid CH | High CH |
| | | 5205 | 5230 | 5255 | 5205 | 5230 | 5255 | 5205 | 5230 | 5255 | 5205 | 5230 | 5255 |
| | | 748.5 MHz | 751 MHz | 753.5 MHz | 748.5 MHz | 751 MHz | 753.5 MHz | 748.5 MHz | 751 MHz | 753.5 MHz | 748.5 MHz | 751 MHz | 753.5 MHz |
| 13 / 5M | Chain 0 | 37.07 | 36.99 | 36.98 | 37.01 | 37.08 | 37.09 | 36.97 | 36.92 | 36.97 | 36.95 | 36.89 | 36.89 |
| | Chain 1 | 37.15 | 37.09 | 37.02 | 37.13 | 37.05 | 37.12 | 36.92 | 36.88 | 36.95 | 36.99 | 36.88 | 36.87 |
| | Chain 2 | 37.07 | 37.08 | 37.02 | 37.05 | 37.06 | 37.1 | 36.95 | 37 | 36.99 | 36.92 | 36.95 | 36.91 |
| | Chain 3 | 36.99 | 37.04 | 37.01 | 37.08 | 37.02 | 37.09 | 36.89 | 36.97 | 36.92 | 36.98 | 36.97 | 36.92 |
| | Total Power | 43.09 | 43.07 | 43.03 | 43.09 | 43.07 | 43.12 | 42.95 | 42.96 | 42.98 | 42.98 | 42.94 | 42.92 |

| Band / BW | Ant | QPSK | 16QAM | 64QAM | 256QAM |
|-----------|-------------|---------|---------|---------|---------|
| | | Mid CH | Mid CH | Mid CH | Mid CH |
| | | 5230 | 5230 | 5230 | 5230 |
| | | 751 MHz | 751 MHz | 751 MHz | 751 MHz |
| 13 / 10M | Chain 0 | 37.1 | 36.99 | 36.92 | 36.87 |
| | Chain 1 | 37.28 | 37.08 | 36.98 | 36.95 |
| | Chain 2 | 37.23 | 37.01 | 36.89 | 36.92 |
| | Chain 3 | 37.23 | 37.03 | 36.92 | 36.97 |
| | Total Power | 43.23 | 43.05 | 42.95 | 42.95 |

| Band / BW | Ant | QPSK | 16QAM | 64QAM | 256QAM |
|--------------------|-------------|---------|---------|---------|---------|
| | | Mid CH | Mid CH | Mid CH | Mid CH |
| | | 5230 | 5230 | 5230 | 5230 |
| | | 751 MHz | 751 MHz | 751 MHz | 751 MHz |
| 2-Carriers / 5M+5M | Chain 0 | 37.04 | 37.01 | 36.88 | 36.85 |
| | Chain 1 | 37.26 | 37.18 | 36.91 | 36.89 |
| | Chain 2 | 37.16 | 37.12 | 36.75 | 36.65 |
| | Chain 3 | 37.14 | 37.09 | 36.72 | 36.56 |
| | Total Power | 43.17 | 43.12 | 42.84 | 42.76 |

ERP Power (dBm)

1TX

| Band / BW | Ant | QPSK | | | 16QAM | | | 64QAM | | | 256QAM | | |
|-------------|--------------|-----------|--------|---------|--------|--------|---------|--------|--------|---------|--------|--------|---------|
| | | Low CH | Mid CH | High CH | Low CH | Mid CH | High CH | Low CH | Mid CH | High CH | Low CH | Mid CH | High CH |
| | | 5205 | 5230 | 5255 | 5205 | 5230 | 5255 | 5205 | 5230 | 5255 | 5205 | 5230 | 5255 |
| | | 748.5 | 751 | 753.5 | 748.5 | 751 | 753.5 | 748.5 | 751 | 753.5 | 748.5 | 751 | 753.5 |
| | | MHz | MHz | MHz | MHz | MHz | MHz | MHz | MHz | MHz | MHz | MHz | MHz |
| 13 / 5M | Chain 0 | 37.07 | 36.99 | 36.98 | 37.01 | 37.08 | 37.09 | 36.97 | 36.92 | 36.97 | 36.95 | 36.89 | 36.89 |
| | Chain 1 | 37.15 | 37.09 | 37.02 | 37.13 | 37.05 | 37.12 | 36.92 | 36.88 | 36.95 | 36.99 | 36.88 | 36.87 |
| | Chain 2 | 37.07 | 37.08 | 37.02 | 37.05 | 37.06 | 37.1 | 36.95 | 37 | 36.99 | 36.92 | 36.95 | 36.91 |
| | Chain 3 | 36.99 | 37.04 | 37.01 | 37.08 | 37.02 | 37.09 | 36.89 | 36.97 | 36.92 | 36.98 | 36.97 | 36.92 |
| | Antenna gain | 8 | 8 | 8 | 8 | 8 | 8 | 8 | 8 | 8 | 8 | 8 | 8 |
| | ERP Chain 0 | 42.92 | 42.84 | 42.83 | 42.86 | 42.93 | 42.94 | 42.82 | 42.77 | 42.82 | 42.8 | 42.74 | 42.74 |
| | ERP Chain 1 | 43 | 42.94 | 42.87 | 42.98 | 42.9 | 42.97 | 42.77 | 42.73 | 42.8 | 42.84 | 42.73 | 42.72 |
| | ERP Chain 2 | 42.92 | 42.93 | 42.87 | 42.9 | 42.91 | 42.95 | 42.8 | 42.85 | 42.84 | 42.77 | 42.8 | 42.76 |
| ERP Chain 3 | 42.84 | 42.89 | 42.86 | 42.93 | 42.87 | 42.94 | 42.74 | 42.82 | 42.77 | 42.83 | 42.82 | 42.77 | |

| Band / BW | Ant | QPSK | 16QAM | 64QAM | 256QAM |
|-------------|--------------|--------|--------|--------|--------|
| | | Mid CH | Mid CH | Mid CH | Mid CH |
| | | 5230 | 5230 | 5230 | 5230 |
| | | 751 | 751 | 751 | 751 |
| | | MHz | MHz | MHz | MHz |
| 13 / 10M | Chain 0 | 37.1 | 36.99 | 36.92 | 36.87 |
| | Chain 1 | 37.28 | 37.08 | 36.98 | 36.95 |
| | Chain 2 | 37.23 | 37.01 | 36.89 | 36.92 |
| | Chain 3 | 37.23 | 37.03 | 36.92 | 36.97 |
| | Antenna gain | 8 | 8 | 8 | 8 |
| | ERP Chain 0 | 42.95 | 42.84 | 42.77 | 42.72 |
| | ERP Chain 1 | 43.13 | 42.93 | 42.83 | 42.8 |
| | ERP Chain 2 | 43.08 | 42.86 | 42.74 | 42.77 |
| ERP Chain 3 | 43.08 | 42.88 | 42.77 | 42.82 | |

| Band / BW | Ant | QPSK | 16QAM | 64QAM | 256QAM |
|-----------------------|--------------|--------|--------|--------|--------|
| | | Mid CH | Mid CH | Mid CH | Mid CH |
| | | 5230 | 5230 | 5230 | 5230 |
| | | 751 | 751 | 751 | 751 |
| | | MHz | MHz | MHz | MHz |
| 2-Carriers / 5M+5M | Chain 0 | 37.04 | 37.01 | 36.88 | 36.85 |
| | Chain 1 | 37.26 | 37.18 | 36.91 | 36.89 |
| | Chain 2 | 37.16 | 37.12 | 36.75 | 36.65 |
| | Chain 3 | 37.14 | 37.09 | 36.72 | 36.56 |
| | Antenna gain | 8 | 8 | 8 | 8 |
| | ERP Chain 0 | 42.89 | 42.86 | 42.73 | 42.7 |
| | ERP Chain 1 | 43.11 | 43.03 | 42.76 | 42.74 |
| | ERP Chain 2 | 43.01 | 42.97 | 42.6 | 42.5 |
| | ERP Chain 3 | 42.99 | 42.94 | 42.57 | 42.41 |

Note: ERP (dBm) = Conducted Output Power (dBm) + Antenna Gain (dBi) – 2.15.

2TX

| Band / BW | Ant | QPSK | | | 16QAM | | | 64QAM | | | 256QAM | | |
|-----------|------------------|-----------|---------|-----------|-----------|---------|-----------|-----------|---------|-----------|-----------|---------|-----------|
| | | Low CH | Mid CH | High CH | Low CH | Mid CH | High CH | Low CH | Mid CH | High CH | Low CH | Mid CH | High CH |
| | | 5205 | 5230 | 5255 | 5205 | 5230 | 5255 | 5205 | 5230 | 5255 | 5205 | 5230 | 5255 |
| | | 748.5 MHz | 751 MHz | 753.5 MHz | 748.5 MHz | 751 MHz | 753.5 MHz | 748.5 MHz | 751 MHz | 753.5 MHz | 748.5 MHz | 751 MHz | 753.5 MHz |
| 13 / 5M | Chain 1 | 37.15 | 37.09 | 37.02 | 37.13 | 37.05 | 37.12 | 36.92 | 36.88 | 36.95 | 36.99 | 36.88 | 36.87 |
| | Chain 2 | 37.07 | 37.08 | 37.02 | 37.05 | 37.06 | 37.1 | 36.95 | 37 | 36.99 | 36.92 | 36.95 | 36.91 |
| | Total Power | 40.12 | 40.10 | 40.03 | 40.10 | 40.07 | 40.12 | 39.95 | 39.95 | 39.98 | 39.97 | 39.93 | 39.90 |
| | Directional Gain | 11.01 | 11.01 | 11.01 | 11.01 | 11.01 | 11.01 | 11.01 | 11.01 | 11.01 | 11.01 | 11.01 | 11.01 |
| | ERP | 48.98 | 48.96 | 48.89 | 48.96 | 48.93 | 48.98 | 48.81 | 48.81 | 48.84 | 48.83 | 48.79 | 48.76 |

| Band / BW | Ant | QPSK | 16QAM | 64QAM | 256QAM |
|-----------|------------------|---------|---------|---------|---------|
| | | Mid CH | Mid CH | Mid CH | Mid CH |
| | | 5230 | 5230 | 5230 | 5230 |
| | | 751 MHz | 751 MHz | 751 MHz | 751 MHz |
| 13 / 10M | Chain 1 | 37.28 | 37.08 | 36.98 | 36.95 |
| | Chain 2 | 37.23 | 37.01 | 36.89 | 36.92 |
| | Total Power | 40.27 | 40.06 | 39.95 | 39.95 |
| | Directional Gain | 11.01 | 11.01 | 11.01 | 11.01 |
| | ERP | 49.13 | 48.92 | 48.81 | 48.81 |

| Band / BW | Ant | QPSK | 16QAM | 64QAM | 256QAM |
|--------------------|------------------|---------|---------|---------|---------|
| | | Mid CH | Mid CH | Mid CH | Mid CH |
| | | 5230 | 5230 | 5230 | 5230 |
| | | 751 MHz | 751 MHz | 751 MHz | 751 MHz |
| 2-Carriers / 5M+5M | Chain 1 | 37.26 | 37.18 | 36.91 | 36.89 |
| | Chain 2 | 37.16 | 37.12 | 36.75 | 36.65 |
| | Total Power | 40.22 | 40.16 | 39.84 | 39.78 |
| | Directional Gain | 11.01 | 11.01 | 11.01 | 11.01 |
| | ERP | 49.08 | 49.02 | 48.70 | 48.64 |

Note:

1. ERP (dBm) = Conducted Output Power (dBm) + Directional Gain (dBi) – 2.15.
2. The 2TX MIMO power was select worst 2 chain total calculation

3TX

| Band / BW | Ant | QPSK | | | 16QAM | | | 64QAM | | | 256QAM | | |
|-----------|------------------|-----------|---------|-----------|-----------|---------|-----------|-----------|---------|-----------|-----------|---------|-----------|
| | | Low CH | Mid CH | High CH | Low CH | Mid CH | High CH | Low CH | Mid CH | High CH | Low CH | Mid CH | High CH |
| | | 5205 | 5230 | 5255 | 5205 | 5230 | 5255 | 5205 | 5230 | 5255 | 5205 | 5230 | 5255 |
| | | 748.5 MHz | 751 MHz | 753.5 MHz | 748.5 MHz | 751 MHz | 753.5 MHz | 748.5 MHz | 751 MHz | 753.5 MHz | 748.5 MHz | 751 MHz | 753.5 MHz |
| 13 / 5M | Chain 1 | 37.15 | 37.09 | 37.02 | 37.13 | 37.05 | 37.12 | 36.92 | 36.88 | 36.95 | 36.99 | 36.88 | 36.87 |
| | Chain 2 | 37.07 | 37.08 | 37.02 | 37.05 | 37.06 | 37.10 | 36.95 | 37.00 | 36.99 | 36.92 | 36.95 | 36.91 |
| | Chain 3 | 36.99 | 37.04 | 37.01 | 37.08 | 37.02 | 37.09 | 36.89 | 36.97 | 36.92 | 36.98 | 36.97 | 36.92 |
| | Total Power | 41.84 | 41.84 | 41.79 | 41.86 | 41.81 | 41.87 | 41.69 | 41.72 | 41.72 | 41.73 | 41.70 | 41.67 |
| | Directional Gain | 12.77 | 12.77 | 12.77 | 12.77 | 12.77 | 12.77 | 12.77 | 12.77 | 12.77 | 12.77 | 12.77 | 12.77 |
| | ERP | 52.46 | 52.46 | 52.41 | 52.48 | 52.43 | 52.49 | 52.31 | 52.34 | 52.34 | 52.35 | 52.32 | 52.29 |

| Band / BW | Ant | QPSK | 16QAM | 64QAM | 256QAM |
|-----------|------------------|---------|---------|---------|---------|
| | | Mid CH | Mid CH | Mid CH | Mid CH |
| | | 5230 | 5230 | 5230 | 5230 |
| | | 751 MHz | 751 MHz | 751 MHz | 751 MHz |
| 13 / 10M | Chain 1 | 37.28 | 37.08 | 36.98 | 36.95 |
| | Chain 2 | 37.23 | 37.01 | 36.89 | 36.92 |
| | Chain 3 | 37.23 | 37.03 | 36.92 | 36.97 |
| | Total Power | 42.02 | 41.81 | 41.70 | 41.72 |
| | Directional Gain | 12.77 | 12.77 | 12.77 | 12.77 |
| | ERP | 52.64 | 52.43 | 52.32 | 52.34 |

| Band / BW | Ant | QPSK | 16QAM | 64QAM | 256QAM |
|--------------------|------------------|---------|---------|---------|---------|
| | | Mid CH | Mid CH | Mid CH | Mid CH |
| | | 5230 | 5230 | 5230 | 5230 |
| | | 751 MHz | 751 MHz | 751 MHz | 751 MHz |
| 2-Carriers / 5M+5M | Chain 1 | 37.26 | 37.18 | 36.91 | 36.89 |
| | Chain 2 | 37.16 | 37.12 | 36.75 | 36.65 |
| | Chain 3 | 37.14 | 37.09 | 36.72 | 36.56 |
| | Total Power | 41.96 | 41.90 | 41.57 | 41.47 |
| | Directional Gain | 12.77 | 12.77 | 12.77 | 12.77 |
| | ERP | 52.58 | 52.52 | 52.19 | 52.09 |

Note:

1. ERP (dBm) = Conducted Output Power (dBm) + Directional Gain (dBi) – 2.15.
2. The 3TX MIMO power was select worst 3 chain total calculation

4TX

| Band / BW | Ant | QPSK | | | 16QAM | | | 64QAM | | | 256QAM | | |
|-----------|------------------|-----------|---------|-----------|-----------|---------|--------------|-----------|---------|-----------|-----------|---------|-----------|
| | | Low CH | Mid CH | High CH | Low CH | Mid CH | High CH | Low CH | Mid CH | High CH | Low CH | Mid CH | High CH |
| | | 5205 | 5230 | 5255 | 5205 | 5230 | 5255 | 5205 | 5230 | 5255 | 5205 | 5230 | 5255 |
| | | 748.5 MHz | 751 MHz | 753.5 MHz | 748.5 MHz | 751 MHz | 753.5 MHz | 748.5 MHz | 751 MHz | 753.5 MHz | 748.5 MHz | 751 MHz | 753.5 MHz |
| 13 / 5M | Chain 0 | 37.07 | 36.99 | 36.98 | 37.01 | 37.08 | 37.09 | 36.97 | 36.92 | 36.97 | 36.95 | 36.89 | 36.89 |
| | Chain 1 | 37.15 | 37.09 | 37.02 | 37.13 | 37.05 | 37.12 | 36.92 | 36.88 | 36.95 | 36.99 | 36.88 | 36.87 |
| | Chain 2 | 37.07 | 37.08 | 37.02 | 37.05 | 37.06 | 37.1 | 36.95 | 37 | 36.99 | 36.92 | 36.95 | 36.91 |
| | Chain 3 | 36.99 | 37.04 | 37.01 | 37.08 | 37.02 | 37.09 | 36.89 | 36.97 | 36.92 | 36.98 | 36.97 | 36.92 |
| | Total Power | 43.09 | 43.07 | 43.03 | 43.09 | 43.07 | 43.12 | 42.95 | 42.96 | 42.98 | 42.98 | 42.94 | 42.92 |
| | Directional Gain | 14.02 | 14.02 | 14.02 | 14.02 | 14.02 | 14.02 | 14.02 | 14.02 | 14.02 | 14.02 | 14.02 | 14.02 |
| | ERP | 54.96 | 54.94 | 54.9 | 54.96 | 54.94 | 54.99 | 54.82 | 54.83 | 54.85 | 54.85 | 54.81 | 54.79 |

| Band / BW | Ant | QPSK | 16QAM | 64QAM | 256QAM |
|-----------|------------------|-------------|----------|----------|----------|
| | | Mid CH | Mid CH | Mid CH | Mid CH |
| | | 5230 MHz | 5230 MHz | 5230 MHz | 5230 MHz |
| 13 / 10M | Chain 0 | 37.1 | 36.99 | 36.92 | 36.87 |
| | Chain 1 | 37.28 | 37.08 | 36.98 | 36.95 |
| | Chain 2 | 37.23 | 37.01 | 36.89 | 36.92 |
| | Chain 3 | 37.23 | 37.03 | 36.92 | 36.97 |
| | Total Power | 43.23 | 43.05 | 42.95 | 42.95 |
| | Directional Gain | 14.02 | 14.02 | 14.02 | 14.02 |
| | ERP | 55.1 | 54.92 | 54.82 | 54.82 |

| Band / BW | Ant | QPSK | 16QAM | 64QAM | 256QAM |
|--------------------|------------------|--------------|----------|----------|----------|
| | | Mid CH | Mid CH | Mid CH | Mid CH |
| | | 5230 MHz | 5230 MHz | 5230 MHz | 5230 MHz |
| 2-Carriers / 5M+5M | Chain 0 | 37.04 | 37.01 | 36.88 | 36.85 |
| | Chain 1 | 37.26 | 37.18 | 36.91 | 36.89 |
| | Chain 2 | 37.16 | 37.12 | 36.75 | 36.65 |
| | Chain 3 | 37.14 | 37.09 | 36.72 | 36.56 |
| | Total Power | 43.17 | 43.12 | 42.84 | 42.76 |
| | Directional Gain | 14.02 | 14.02 | 14.02 | 14.02 |
| | ERP | 55.04 | 54.99 | 54.71 | 54.63 |

Note: ERP (dBm) = Conducted Output Power (dBm) + Directional Gain (dBi) – 2.15.

4.2 Modulation Characteristics Measurement

4.2.1 Limits of Modulation Characteristics

N/A

4.2.2 Test Procedure

Connect the EUT to Communication Simulator via the antenna connector, the frequency band is set as EUT supported Modulation and Channels, the EUT output is matched with 50 ohm load, the waveform quality and constellation of the EUT was tested.

4.2.3 Test Setup



4.2.4 Test Results

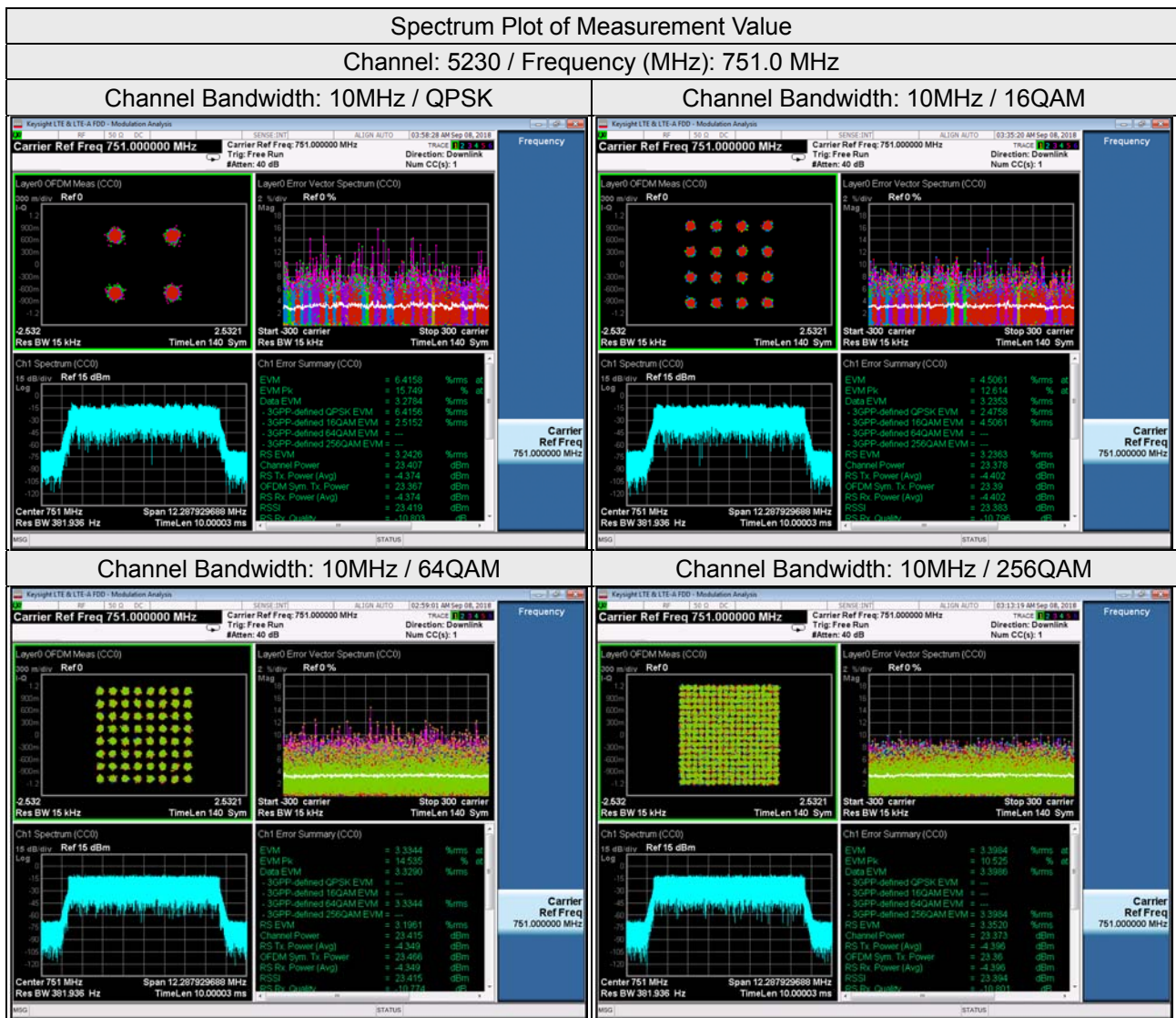

4.3 Frequency Stability Measurement

4.3.1 Limits of Frequency Stability Measurement

According to the FCC part 2.1055 shall be tested the frequency stability. The rule is defined that "The frequency stability shall be sufficient to ensure that the fundamental emission stays within the authorized frequency block." The test extreme voltage is according to the 2.1055(d)(1) Vary primary supply voltage from 85 to 115 percent of the nominal value for other than hand carried battery equipment and the extreme temperature rule is comply with specification of EUT $-30^{\circ}\text{C} \sim 50^{\circ}\text{C}$.

4.3.2 Test Procedure

- Device is placed at the oven room. The oven room could control the temperatures and humidity. Power warm up is at least 15 min and power applied should perform before recording frequency error.
- EUT is connected the external power supply to control the DC input power. The test voltage range is from minimum to maximum working voltage. Each step shall be record the frequency error rate.
- The temperature range step is 10 degrees in this test items. All temperature levels shall be hold the $\pm 0.5^{\circ}\text{C}$ during the measurement testing. The each temperature step shall be at least 0.5 hours, consider the EUT could be test under the stability condition.

Note: The frequency error was recorded frequency error from the communication simulator.

4.3.3 Test Setup

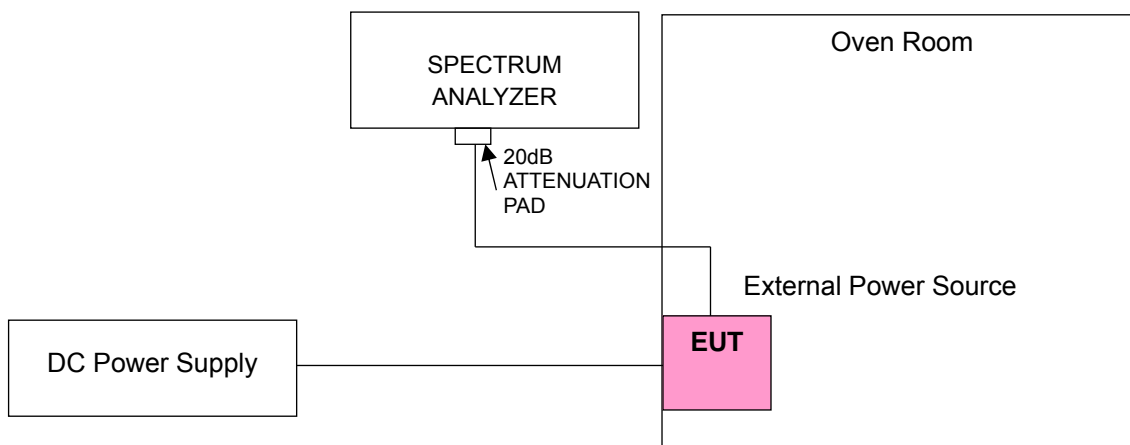

4.3.4 Test Results

Frequency Error vs. Voltage

| Voltage (Volts) | LTE Band 13 | | | |
|--------------------|--------------------------|-----------------------|-----------------|-----------------------|
| | Channel Bandwidth: 5 MHz | | | |
| | Low Channel | | High Channel | |
| | Frequency (MHz) | Frequency Error (ppm) | Frequency (MHz) | Frequency Error (ppm) |
| 55.2 | 748.500001 | 0.002 | 753.500004 | 0.005 |
| 48 | 748.500004 | 0.005 | 753.500003 | 0.003 |
| 40.8 | 748.500002 | 0.002 | 753.500001 | 0.001 |

Note: The applicant defined the normal working voltage is from 40.8Vdc to 55.2Vdc.

Frequency Error vs. Temperature

| Temp. (°C) | LTE Band 13 | | | |
|------------|--------------------------|-----------------------|-----------------|-----------------------|
| | Channel Bandwidth: 5 MHz | | | |
| | Low Channel | | High Channel | |
| | Frequency (MHz) | Frequency Error (ppm) | Frequency (MHz) | Frequency Error (ppm) |
| -30 | 748.500001 | 0.002 | 753.500001 | 0.002 |
| -20 | 748.500003 | 0.004 | 753.500002 | 0.003 |
| -10 | 748.500002 | 0.003 | 753.500001 | 0.001 |
| 0 | 748.500003 | 0.004 | 753.500003 | 0.004 |
| 10 | 748.500003 | 0.004 | 753.500001 | 0.002 |
| 20 | 748.499997 | -0.003 | 753.499997 | -0.004 |
| 30 | 748.499997 | -0.004 | 753.499997 | -0.004 |
| 40 | 748.499998 | -0.002 | 753.499997 | -0.004 |
| 50 | 748.499997 | -0.003 | 753.499999 | -0.001 |
| 60 | 748.499997 | -0.005 | 753.499998 | -0.003 |

Frequency Error vs. Voltage

| Voltage (Volts) | LTE Band 13 | |
|--------------------|---------------------------|-----------------------|
| | Channel Bandwidth: 10 MHz | |
| | CH 5230 | |
| | Frequency (MHz) | Frequency Error (ppm) |
| 55.2 | 751.000003 | 0.003 |
| 48 | 751.000002 | 0.003 |
| 40.8 | 751.000004 | 0.005 |

Note: The applicant defined the normal working voltage is from 40.8Vdc to 55.2Vdc.

Frequency Error vs. Temperature

| Temp. (°C) | LTE Band 13 | |
|------------|---------------------------|-----------------------|
| | Channel Bandwidth: 10 MHz | |
| | CH 5230 | |
| | Frequency (MHz) | Frequency Error (ppm) |
| -30 | 751.000002 | 0.002 |
| -20 | 751.000003 | 0.004 |
| -10 | 751.000002 | 0.002 |
| 0 | 751.000001 | 0.001 |
| 10 | 751.000003 | 0.005 |
| 20 | 750.999999 | -0.002 |
| 30 | 750.999998 | -0.002 |
| 40 | 750.999997 | -0.004 |
| 50 | 750.999999 | -0.002 |
| 60 | 750.999997 | -0.004 |

4.4 Emission Bandwidth Measurement

4.4.1 Limits of Emission Bandwidth Measurement

According to FCC 27.53(g)(1) specified that emission bandwidth is defined as the width of the signal between two points, one below the carrier center frequency and one above the carrier center frequency, outside of which all emissions are attenuated at least 26dB below the transmitter power.

4.4.2 Test Procedure

The transmitter output was connected to the spectrum analyzer through an attenuator. The bandwidth of the fundamental frequency was measured by spectrum analyzer with RBW = 51kHz and VBW = 150kHz (Channel Bandwidth: 5MHz), RBW = 100kHz and VBW = 300kHz (Channel Bandwidth: 10MHz). The 26dB bandwidth is defined as the total spectrum the power of which is higher than peak power minus 26dB.

4.4.3 Test Setup

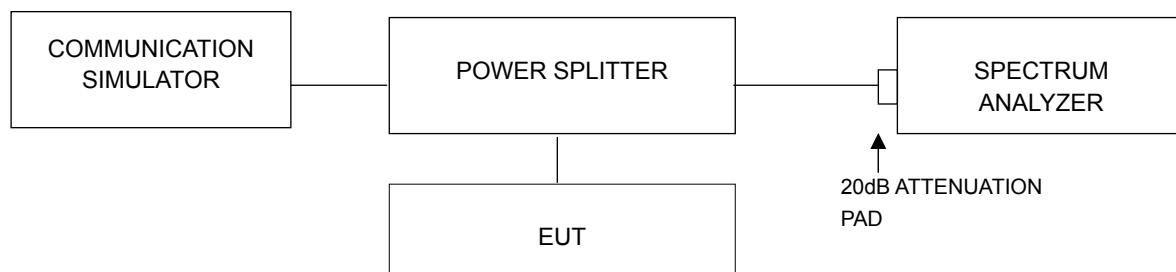

4.4.4 Test Result

Single Mode

| Channel Bandwidth: 5MHz | | | | | | | | | |
|-------------------------|-----------------|---------|---------|---------|---------|---------|---------|---------|---------|
| 26dBc Bandwidth (MHz) | | | | | | | | | |
| Channel | Frequency (MHz) | QPSK | | | | 16QAM | | | |
| | | Chain 0 | Chain 1 | Chain 2 | Chain 3 | Chain 0 | Chain 1 | Chain 2 | Chain 3 |
| 5205 | 748.5 | 4.77 | 4.77 | 4.77 | 4.78 | 4.77 | 4.78 | 4.78 | 4.78 |
| 5230 | 751.0 | 4.78 | 4.76 | 4.77 | 4.76 | 4.77 | 4.76 | 4.76 | 4.77 |
| 5255 | 753.5 | 4.75 | 4.76 | 4.77 | 4.77 | 4.77 | 4.79 | 4.76 | 4.78 |
| Channel | Frequency (MHz) | 64QAM | | | | 256QAM | | | |
| | | Chain 0 | Chain 1 | Chain 2 | Chain 3 | Chain 0 | Chain 1 | Chain 2 | Chain 3 |
| 5205 | 748.5 | 4.76 | 4.77 | 4.78 | 4.77 | 4.75 | 4.77 | 4.78 | 4.78 |
| 5230 | 751.0 | 4.78 | 4.76 | 4.78 | 4.78 | 4.79 | 4.78 | 4.77 | 4.76 |
| 5255 | 753.5 | 4.78 | 4.76 | 4.77 | 4.77 | 4.78 | 4.77 | 4.77 | 4.77 |

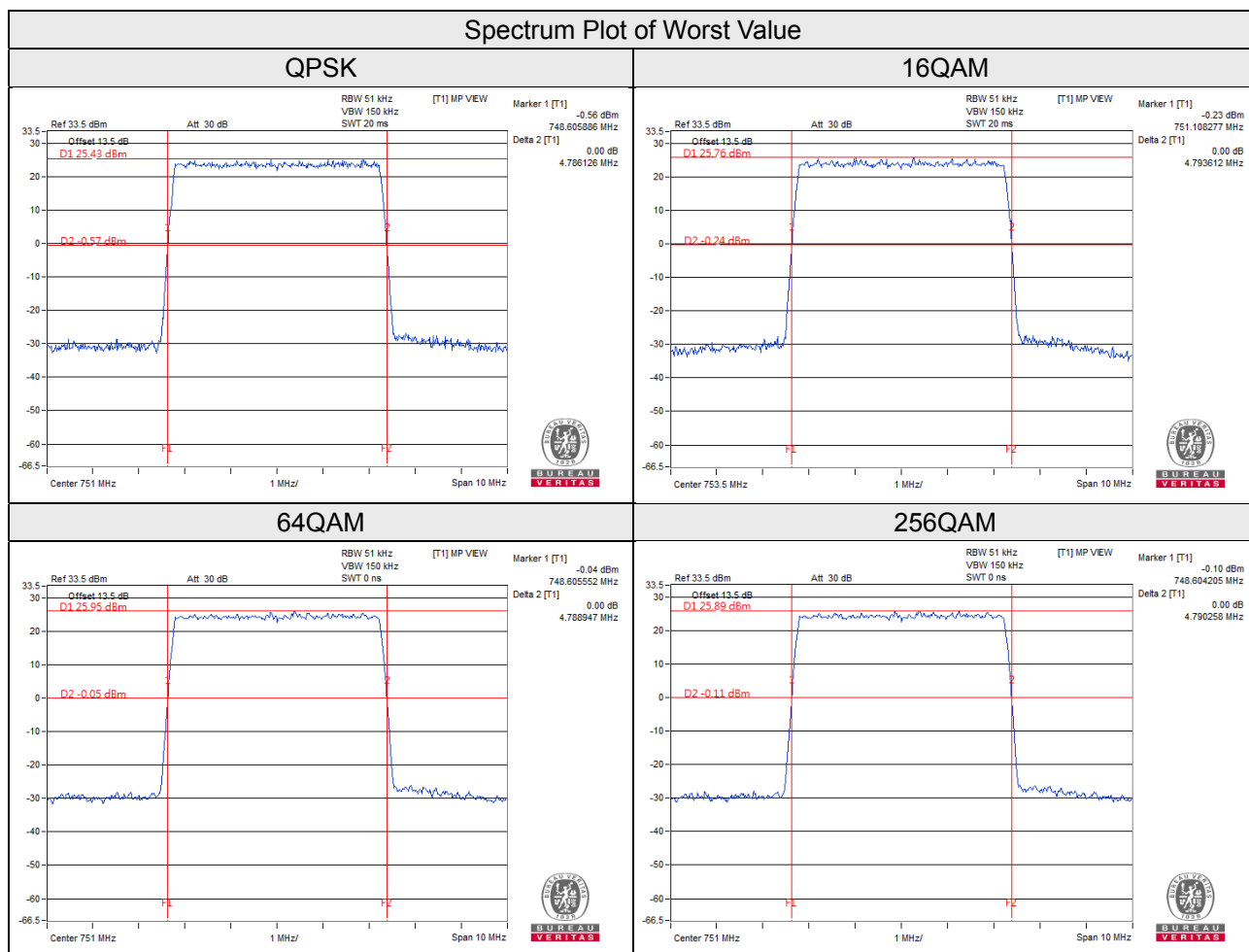

| Channel Bandwidth: 5MHz | | | | | | | | | |
|--------------------------|-----------------|---------|---------|---------|---------|---------|---------|---------|---------|
| Occupied Bandwidth (MHz) | | | | | | | | | |
| Channel | Frequency (MHz) | QPSK | | | | 16QAM | | | |
| | | Chain 0 | Chain 1 | Chain 2 | Chain 3 | Chain 0 | Chain 1 | Chain 2 | Chain 3 |
| 5205 | 748.5 | 4.46 | 4.48 | 4.46 | 4.46 | 4.48 | 4.48 | 4.46 | 4.46 |
| 5230 | 751.0 | 4.48 | 4.48 | 4.48 | 4.50 | 4.46 | 4.48 | 4.48 | 4.48 |
| 5255 | 753.5 | 4.45 | 4.48 | 4.48 | 4.48 | 4.46 | 4.48 | 4.46 | 4.45 |
| Channel | Frequency (MHz) | 64QAM | | | | 256QAM | | | |
| | | Chain 0 | Chain 1 | Chain 2 | Chain 3 | Chain 0 | Chain 1 | Chain 2 | Chain 3 |
| 5205 | 748.5 | 4.48 | 4.48 | 4.46 | 4.46 | 4.48 | 4.48 | 4.46 | 4.46 |
| 5230 | 751.0 | 4.48 | 4.48 | 4.46 | 4.48 | 4.46 | 4.48 | 4.46 | 4.48 |
| 5255 | 753.5 | 4.48 | 4.48 | 4.45 | 4.48 | 4.45 | 4.48 | 4.46 | 4.46 |

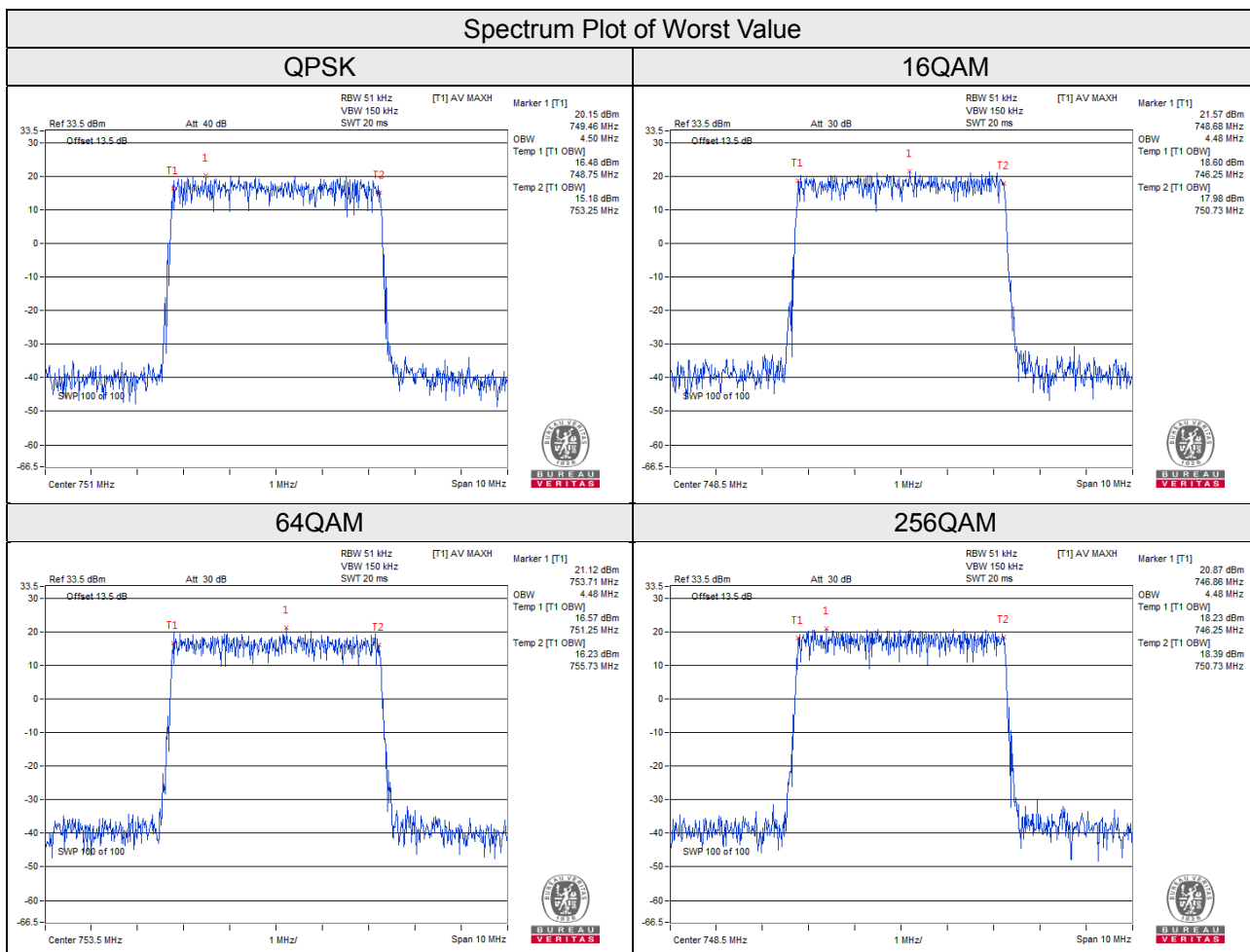

| Channel Bandwidth: 10MHz | | | | | | | | | |
|--------------------------|-----------------|---------|---------|---------|---------|---------|---------|---------|---------|
| 26dBc Bandwidth (MHz) | | | | | | | | | |
| Channel | Frequency (MHz) | QPSK | | | | 16QAM | | | |
| | | Chain 0 | Chain 1 | Chain 2 | Chain 3 | Chain 0 | Chain 1 | Chain 2 | Chain 3 |
| 5230 | 751.0 | 9.63 | 9.54 | 9.65 | 9.62 | 9.62 | 9.52 | 9.64 | 9.64 |
| Channel | Frequency (MHz) | 64QAM | | | | 256QAM | | | |
| | | Chain 0 | Chain 1 | Chain 2 | Chain 3 | Chain 0 | Chain 1 | Chain 2 | Chain 3 |
| 5230 | 751.0 | 9.61 | 9.54 | 9.61 | 9.64 | 9.64 | 9.49 | 9.61 | 9.61 |

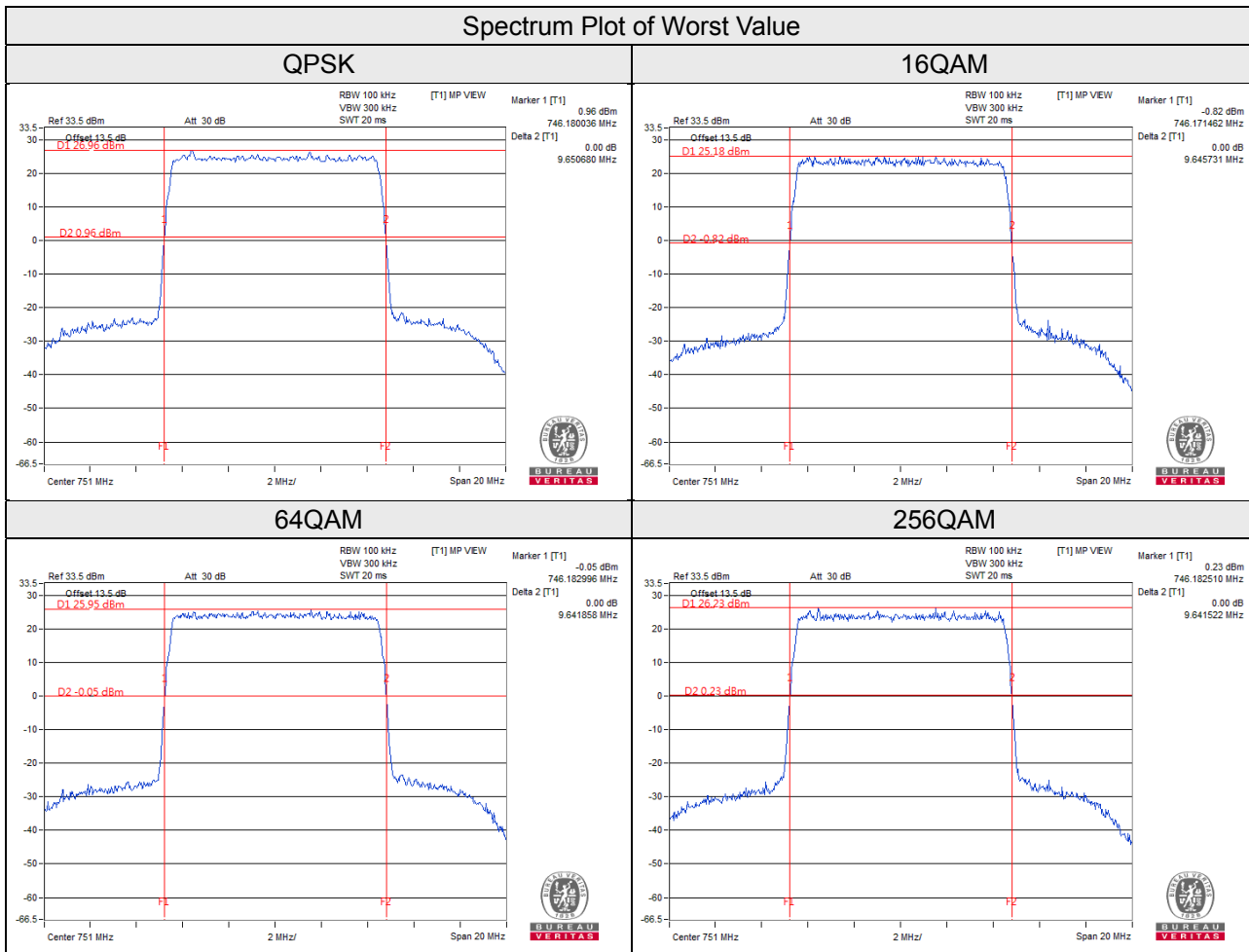

Channel Bandwidth: 10MHz

Occupied Bandwidth (MHz)

| Channel | Frequency (MHz) | QPSK | | | | 16QAM | | | |
|---------|-----------------|---------|---------|---------|---------|---------|---------|---------|---------|
| | | Chain 0 | Chain 1 | Chain 2 | Chain 3 | Chain 0 | Chain 1 | Chain 2 | Chain 3 |
| 5230 | 751.0 | 8.96 | 8.96 | 9.00 | 8.93 | 8.96 | 8.96 | 9.00 | 8.96 |
| Channel | Frequency (MHz) | 64QAM | | | | 256QAM | | | |
| | | Chain 0 | Chain 1 | Chain 2 | Chain 3 | Chain 0 | Chain 1 | Chain 2 | Chain 3 |
| 5230 | 751.0 | 8.93 | 8.96 | 8.96 | 8.93 | 9.00 | 8.93 | 8.96 | 8.93 |

Spectrum Plot of Worst Value

QPSK

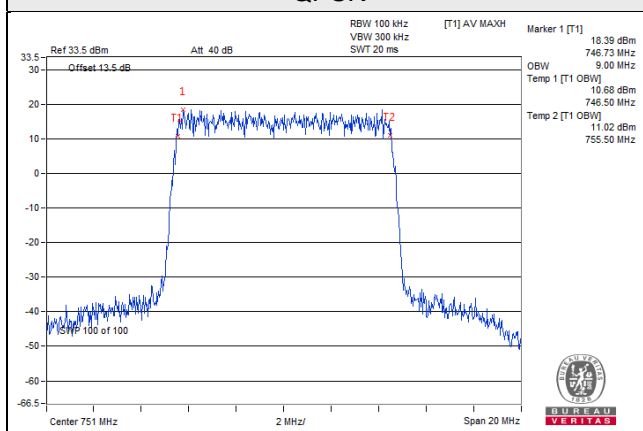

16QAM

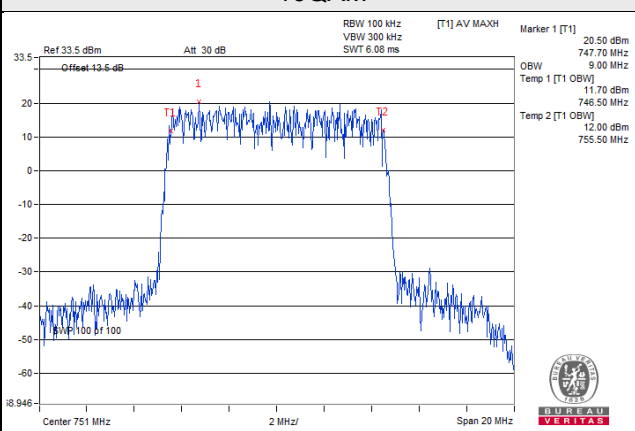

64QAM

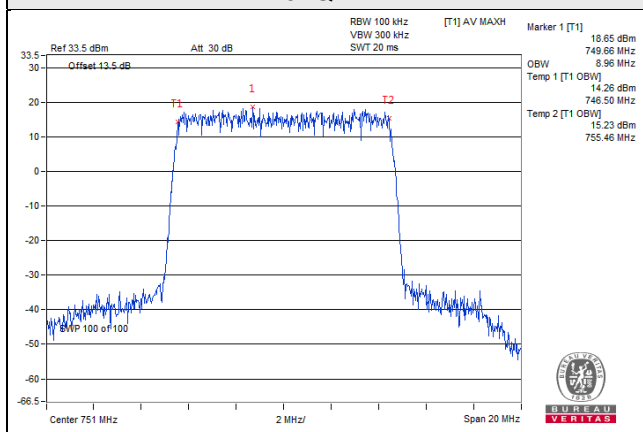

256QAM

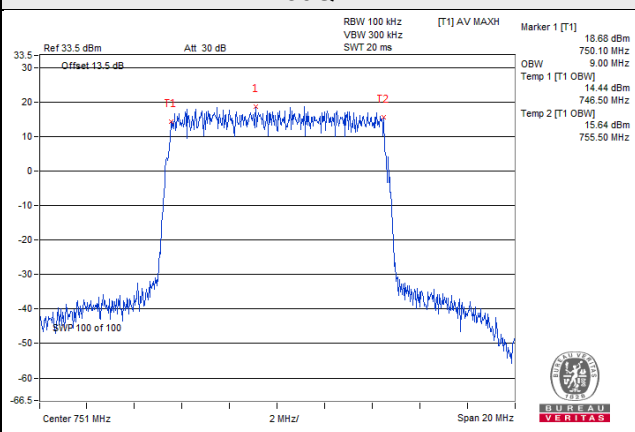

2-Carriers Mode

| Channel Bandwidth: 5MHz + 5MHz | | | | | | | | | |
|--------------------------------|-----------------|---------|---------|---------|---------|---------|---------|---------|---------|
| 26dBc Bandwidth (MHz) | | | | | | | | | |
| Channel | Frequency (MHz) | QPSK | | | | 16QAM | | | |
| | | Chain 0 | Chain 1 | Chain 2 | Chain 3 | Chain 0 | Chain 1 | Chain 2 | Chain 3 |
| 5230 | 751.0 | 9.83 | 9.84 | 9.85 | 9.86 | 9.85 | 9.87 | 9.84 | 9.86 |
| Channel | Frequency (MHz) | 64QAM | | | | 256QAM | | | |
| | | Chain 0 | Chain 1 | Chain 2 | Chain 3 | Chain 0 | Chain 1 | Chain 2 | Chain 3 |
| 5230 | 751.0 | 9.84 | 9.85 | 9.86 | 9.84 | 9.83 | 9.85 | 9.86 | 9.85 |

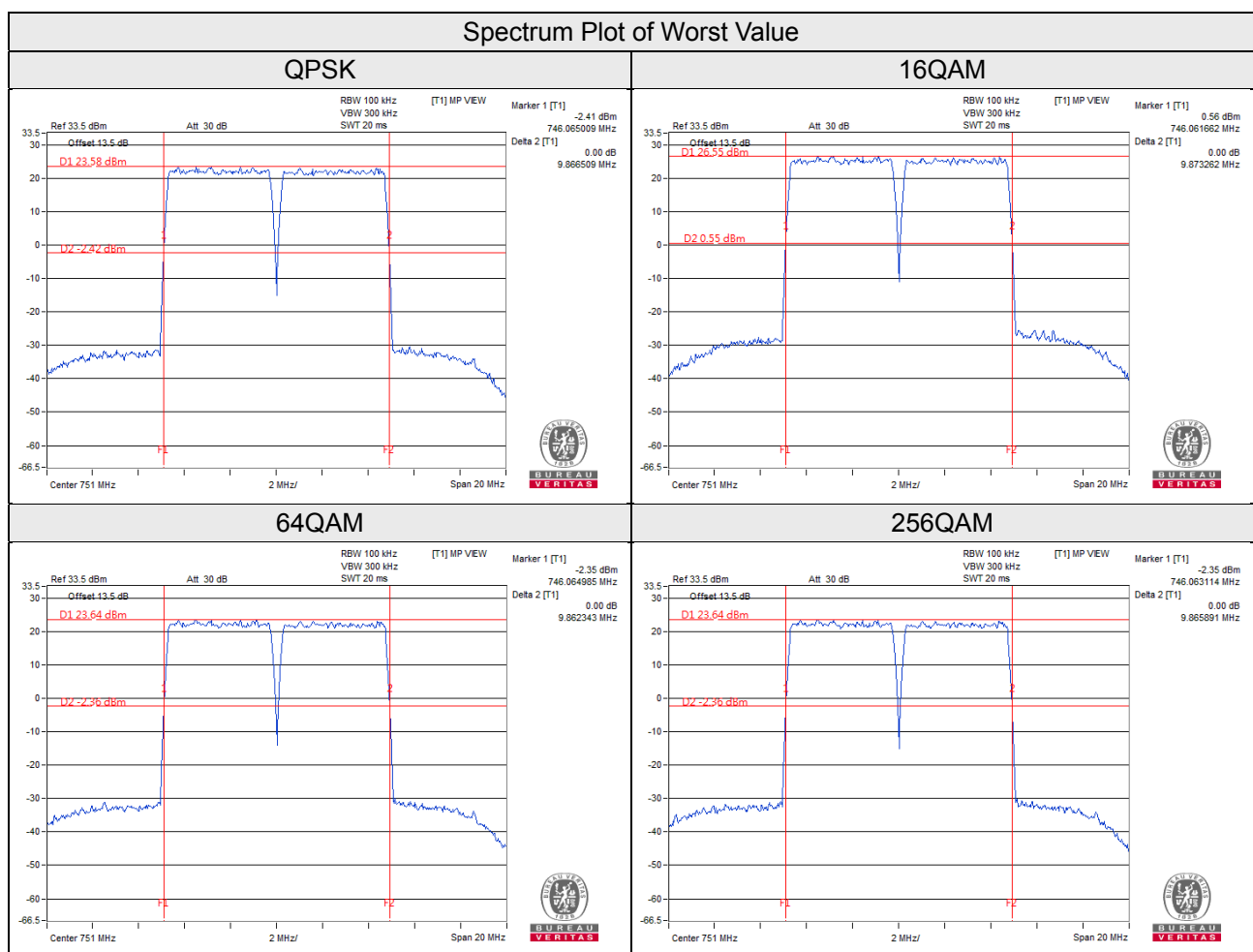

| Channel Bandwidth: 5MHz + 5MHz | | | | | | | | | |
|--------------------------------|-----------------|---------|---------|---------|---------|---------|---------|---------|---------|
| Occupied Bandwidth (MHz) | | | | | | | | | |
| Channel | Frequency (MHz) | QPSK | | | | 16QAM | | | |
| | | Chain 0 | Chain 1 | Chain 2 | Chain 3 | Chain 0 | Chain 1 | Chain 2 | Chain 3 |
| 5230 | 751.0 | 9.43 | 9.43 | 9.43 | 9.43 | 9.46 | 9.43 | 9.43 | 9.43 |
| Channel | Frequency (MHz) | 64QAM | | | | 256QAM | | | |
| | | Chain 0 | Chain 1 | Chain 2 | Chain 3 | Chain 0 | Chain 1 | Chain 2 | Chain 3 |
| 5230 | 751.0 | 9.43 | 9.43 | 9.43 | 9.46 | 9.46 | 9.43 | 9.40 | 9.40 |

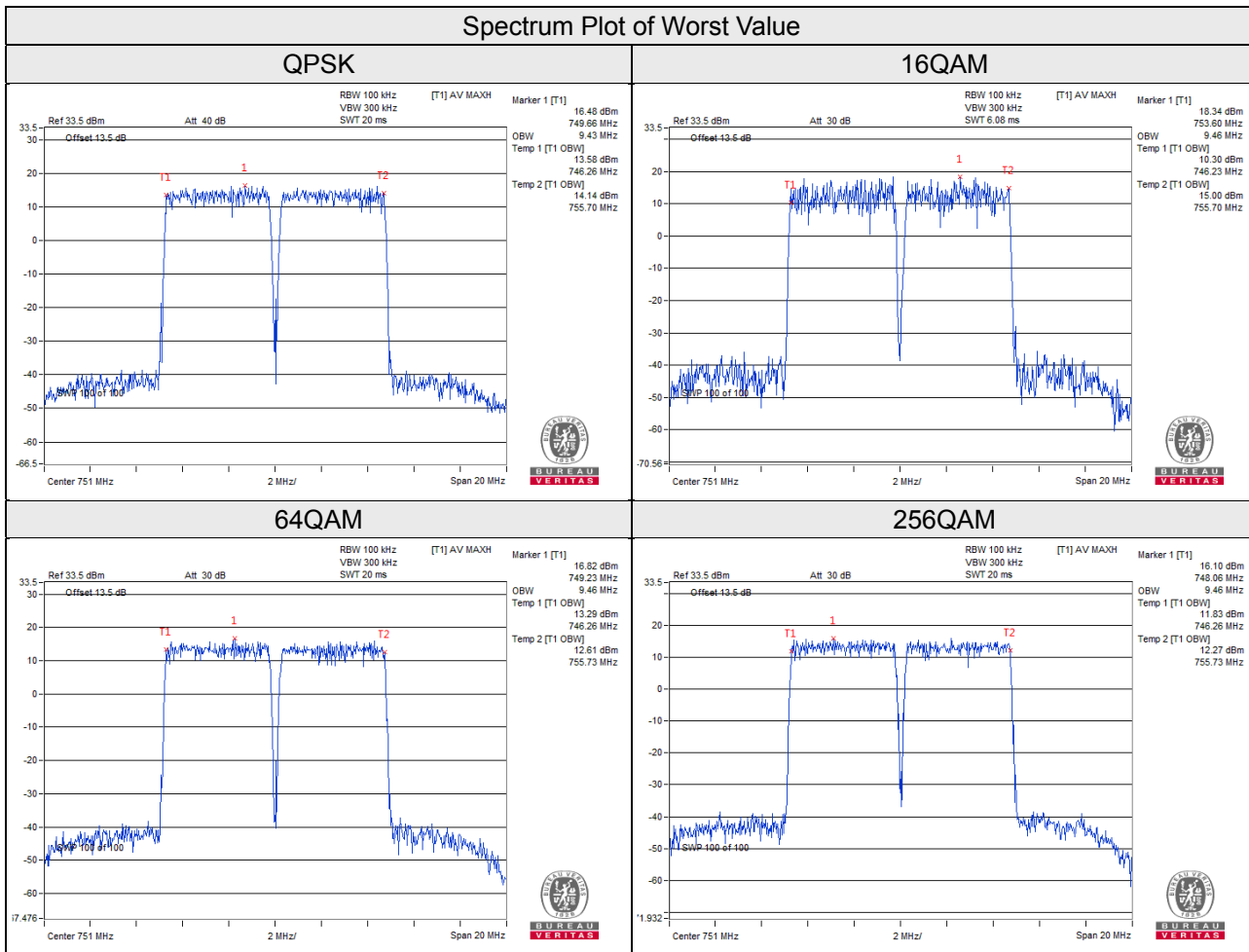

4.5 Band Edge Measurement

4.5.1 Limits of Band Edge Measurement

According to FCC 27.53(c), for operations in the 747 to 762 MHz band and the 777 to 792 MHz band, the power of any emission outside the licensee's frequency band(s) of operation shall be attenuated below the transmitter power (P) within the licensed band(s) of operation, measured watts, in accordance with the following:

- (1) On any frequency outside the 747 to 762 MHz band, the power of any emission shall be attenuated outside the band below the transmitter power (P) by at least $43 + 10 \log (P)$ dB.

Note: The Device has 4x4 MIMO function, so the limit of spurious emissions needs to be reduced by $10 \log (\text{Numbers}_{\text{Ant}})$ according to FCC KDB 662911 D01 guidance.

{The limits is adjusted to $-13 \text{dBm} - 10 * \log(4) = -19.02 \text{dBm}$ }

4.5.2 Test Setup

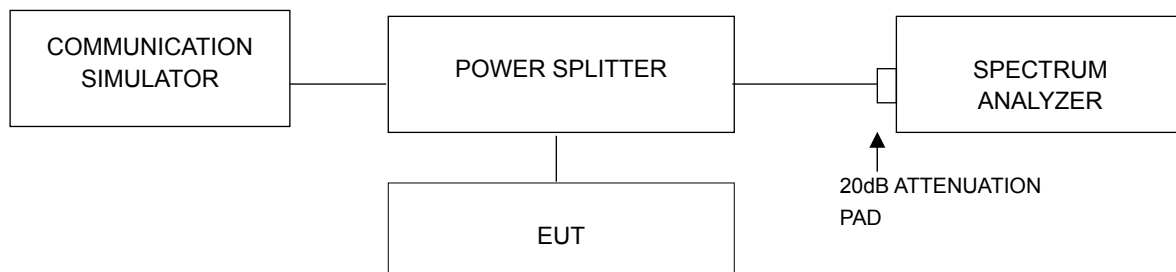

4.5.3 Test Procedures

- a. The EUT was set up for the rated peak power. The power was measured with Spectrum Analyzer. All measurements were done at 3 channels: low, middle and high operational frequency range.
- b. The center frequency of spectrum is the band edge frequency and span is RBW = 51kHz and VBW = 150kHz (Channel Bandwidth: 5MHz), RBW = 100kHz and VBW = 300kHz (Channel Bandwidth: 10MHz).
- c. Record the max trace plot into the test report.

4.5.4 Test Results

Single Mode (Chain 0)

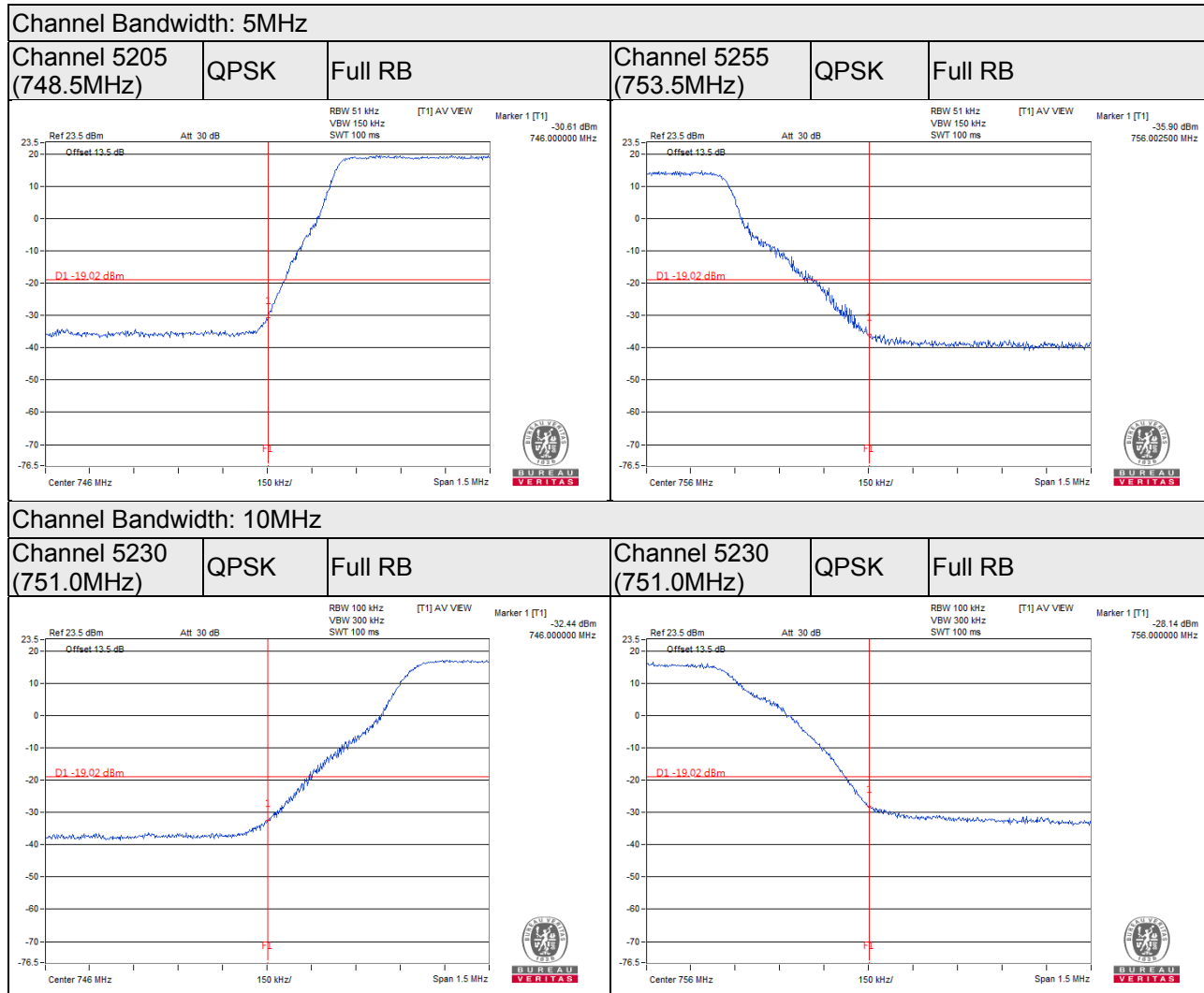

Single Mode (Chain 1)

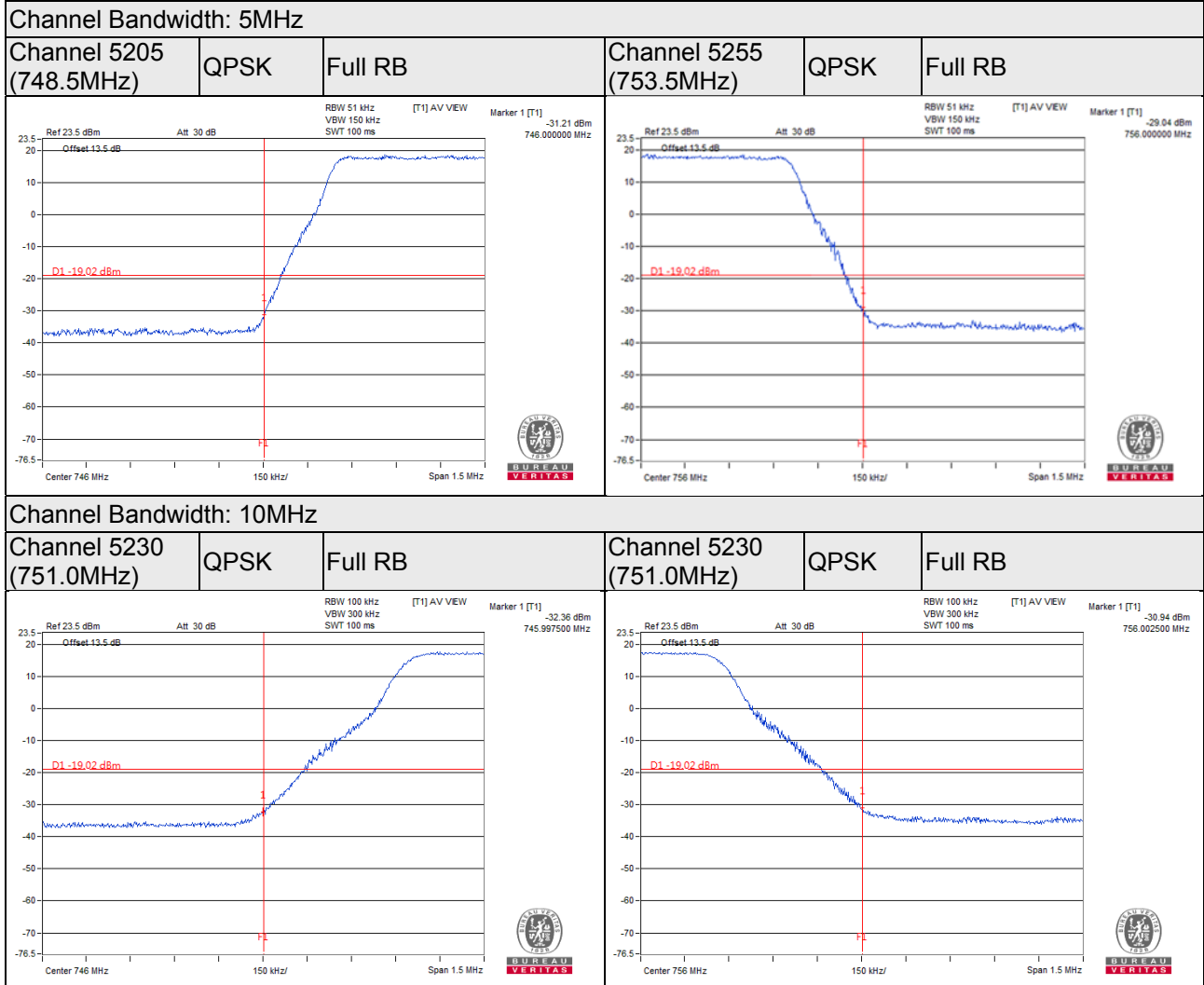

Single Mode (Chain 2)

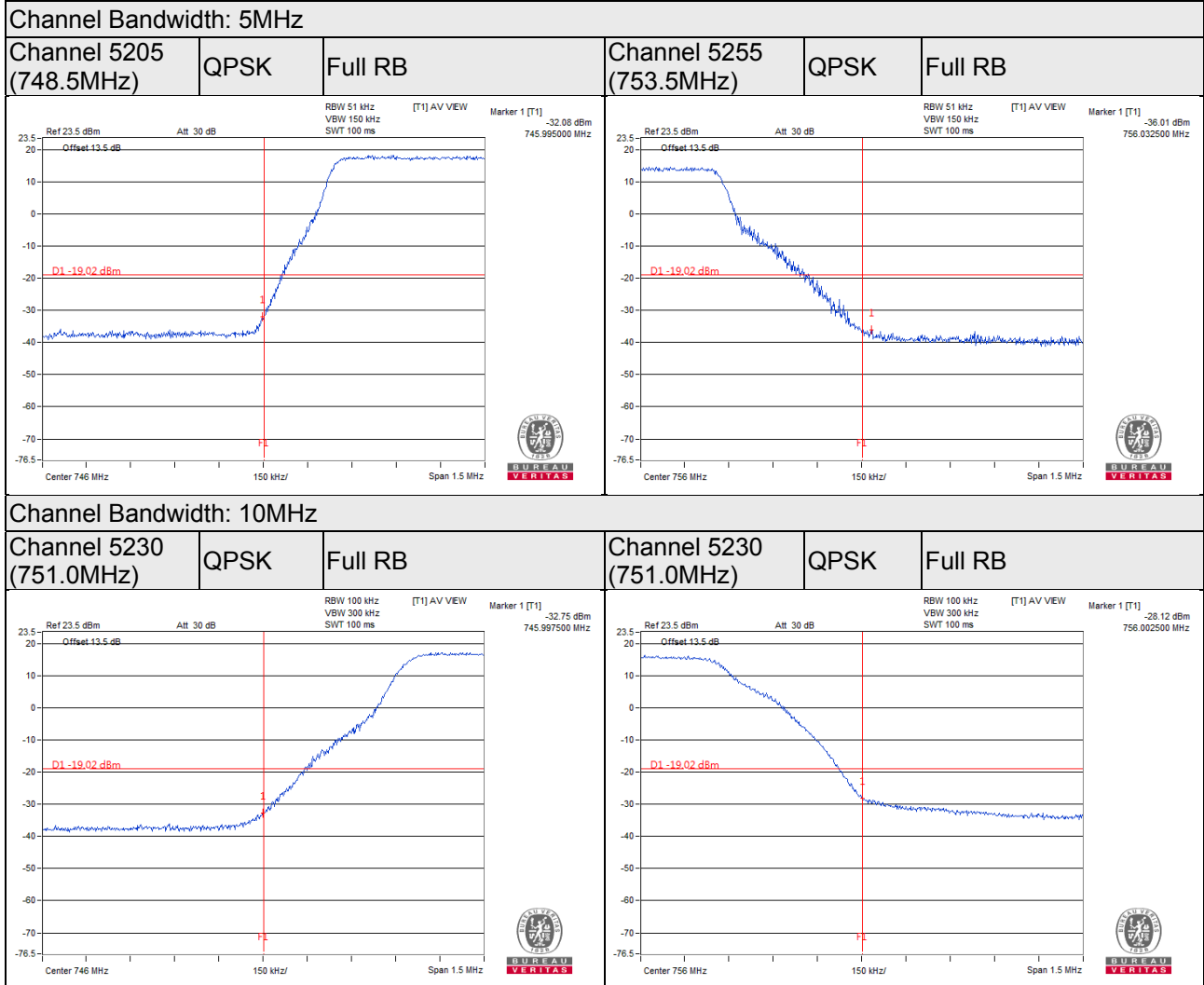

Single Mode (Chain 3)

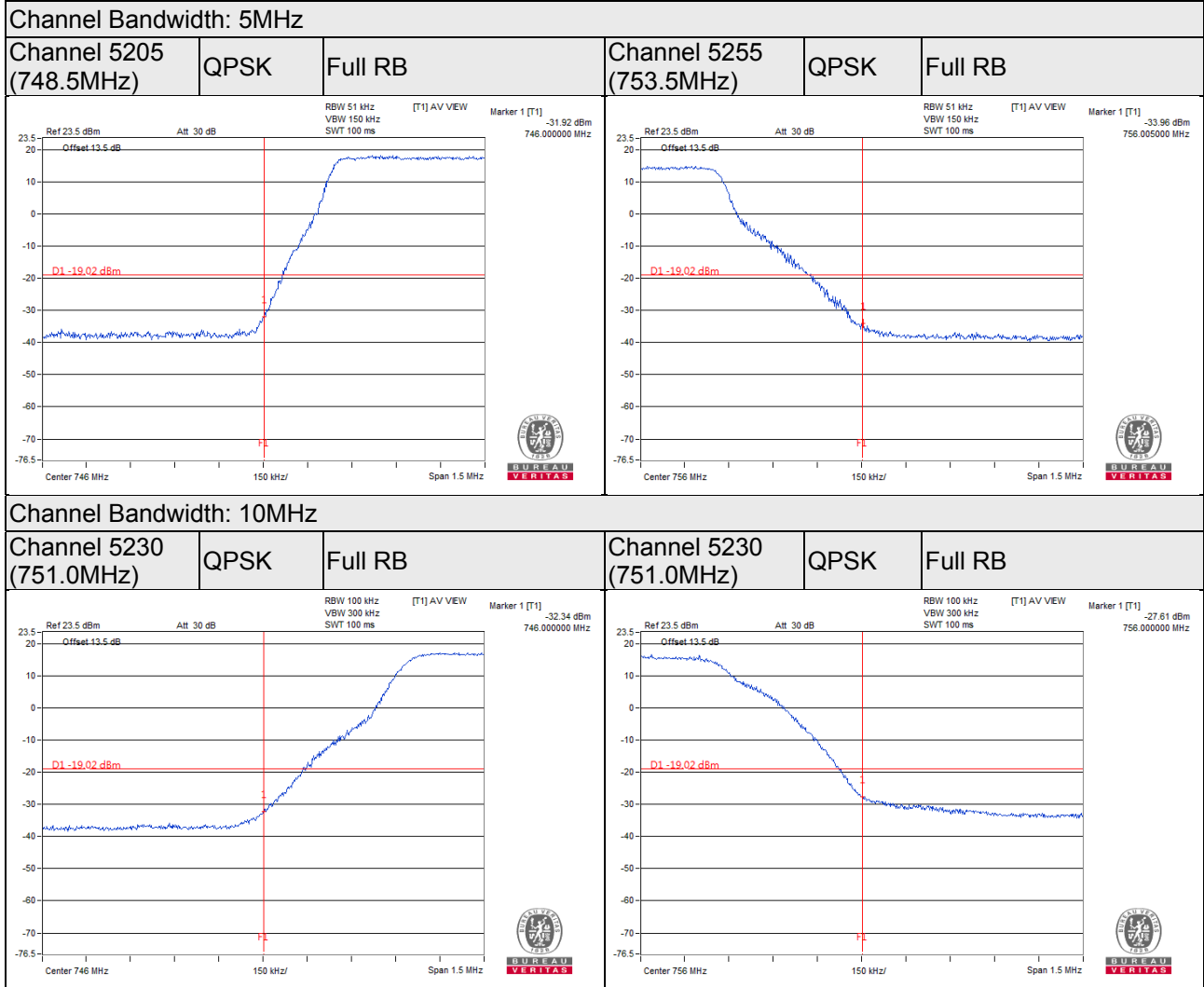

2-Carriers Mode (Chain 0)

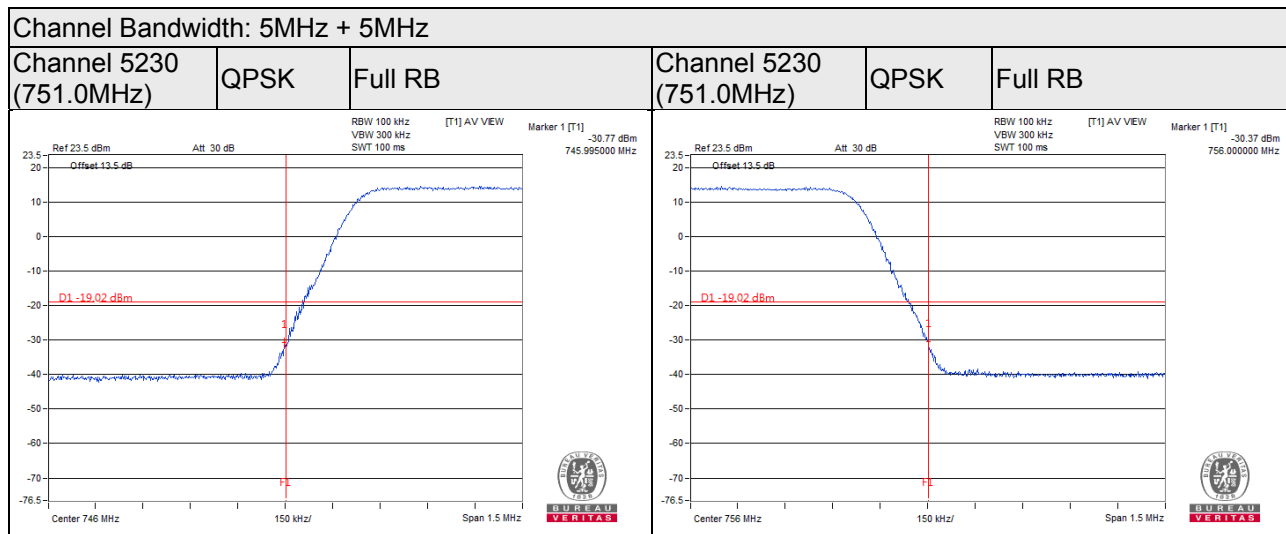

2-Carriers Mode (Chain 1)

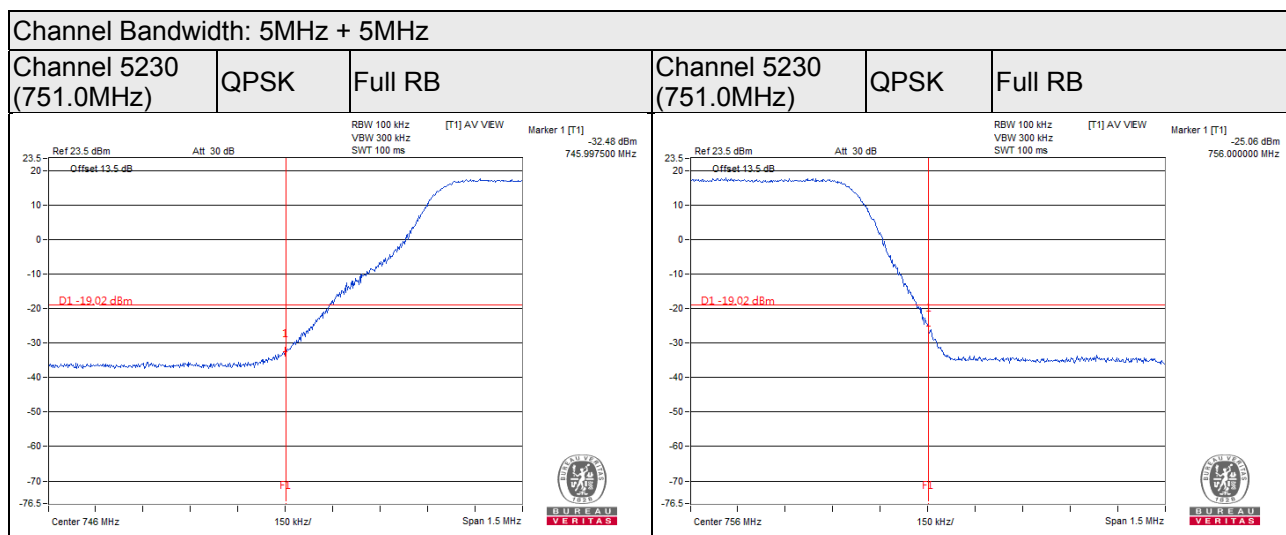

2-Carriers Mode (Chain 2)

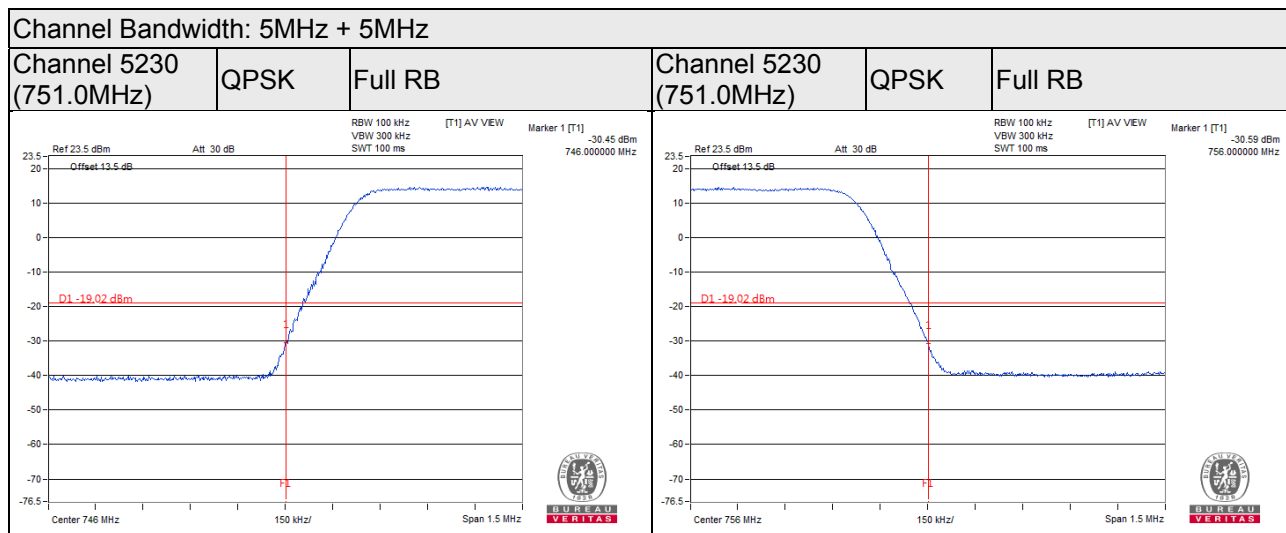

2-Carriers Mode (Chain 3)

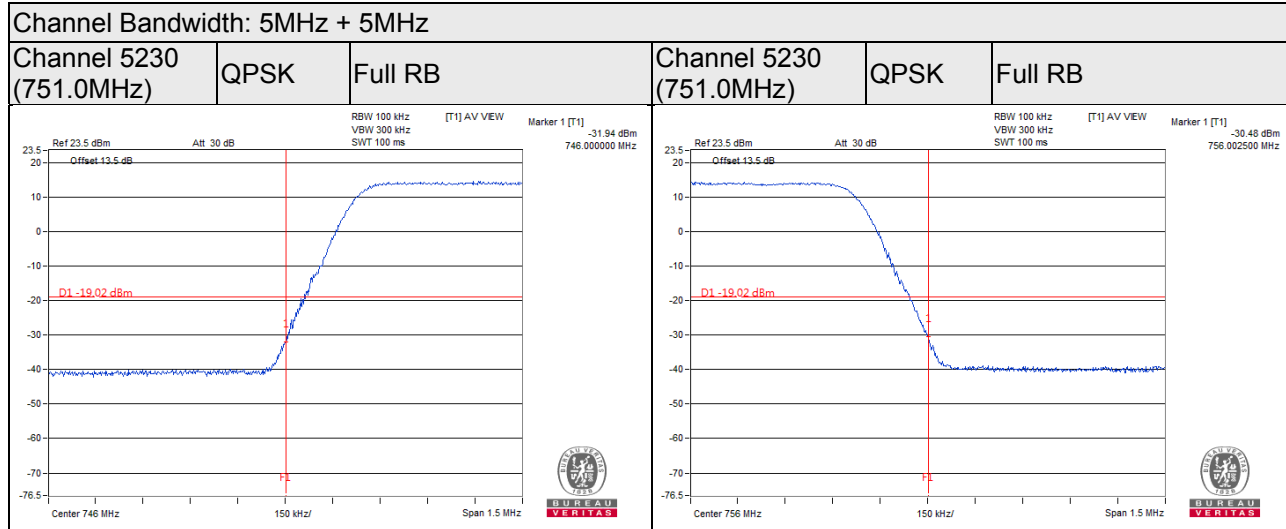

4.6 Peak to Average Ratio

4.6.1 Limits of Peak to Average Ratio Measurement

In measuring transmissions in this band using an average power technique, the peak to-average ratio (PAR) of the transmission may not exceed 13 dB

4.6.2 Test Setup

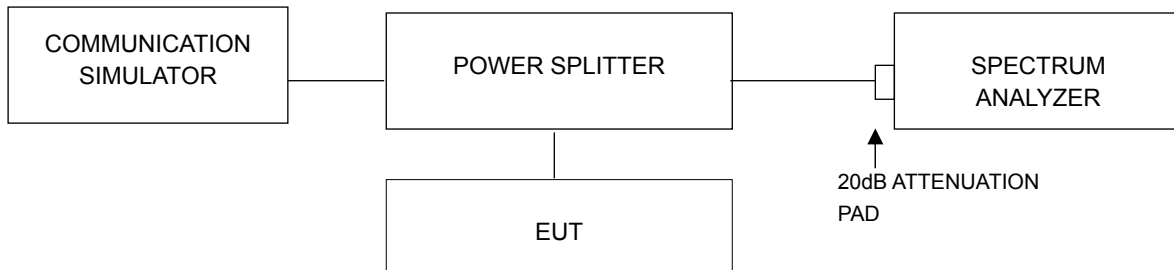

4.6.3 Test Procedures

- Set resolution/measurement bandwidth \geq signal's occupied bandwidth;
- Set the number of counts to a value that stabilizes the measured CCDF curve;
- Record the maximum PAPR level associated with a probability of 0.1%.

4.6.4 Test Results

| Channel Bandwidth: 5MHz | | | | | |
|-------------------------|-----------------|----------------------------|-------|-------|--------|
| Channel | Frequency (MHz) | Peak To Average Ratio (dB) | | | |
| | | QPSK | 16QAM | 64QAM | 256QAM |
| 5205 | 748.5 | 7.15 | 7.15 | 7.16 | 7.16 |
| 5230 | 751.0 | 7.15 | 7.16 | 7.15 | 7.16 |
| 5255 | 753.5 | 7.15 | 7.16 | 7.16 | 7.15 |

| Channel Bandwidth: 10MHz | | | | | |
|--------------------------|-----------------|----------------------------|-------|-------|--------|
| Channel | Frequency (MHz) | Peak To Average Ratio (dB) | | | |
| | | QPSK | 16QAM | 64QAM | 256QAM |
| 5230 | 751.0 | 7.16 | 7.15 | 7.15 | 7.15 |

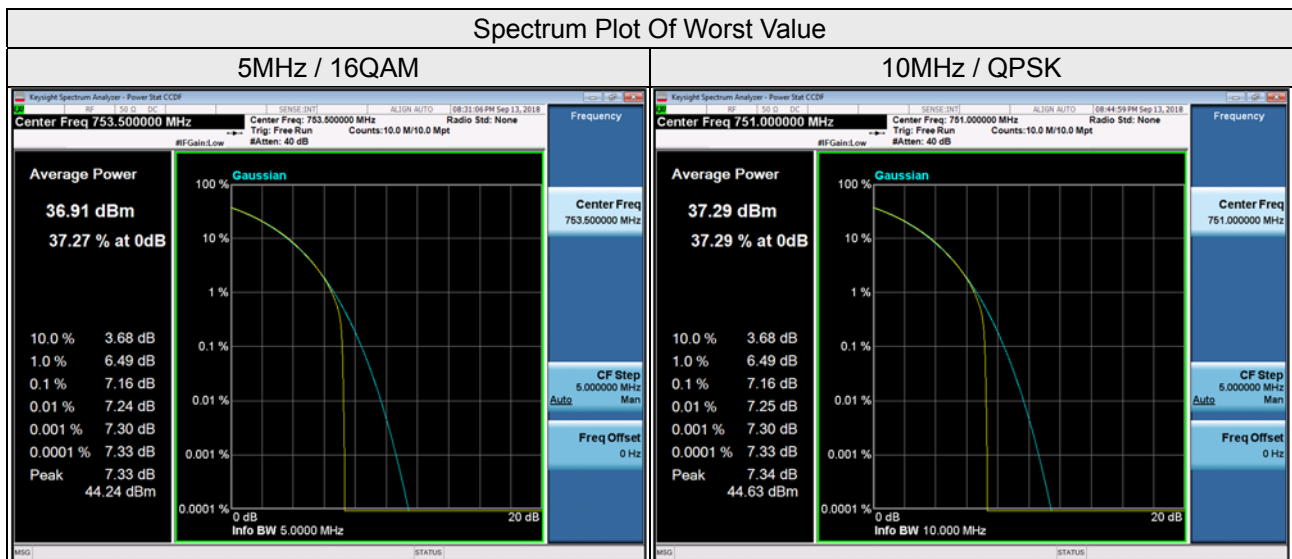

4.7 Conducted Spurious Emissions

4.7.1 Limits of Conducted Spurious Emissions Measurement

According to FCC 27.53(c), for operations in the 747 to 762 MHz band and the 777 to 792 MHz band, the power of any emission outside the licensee's frequency band(s) of operation shall be attenuated below the transmitter power (P) within the licensed band(s) of operation, measured watts, in accordance with the following:

- (1) On any frequency outside the 747 to 762 MHz band, the power of any emission shall be attenuated outside the band below the transmitter power (P) by at least $43 + 10 \log (P)$ dB.

Note: The Device has 4x4 MIMO function, so the limit of spurious emissions needs to be reduced by $10\log(\text{Numbers}_{\text{Ant}})$ according to FCC KDB 662911 D01 guidance.

{The limits is adjusted to $-13\text{dBm} - 10*\log(4) = -19.02\text{dBm}$ }

- (2) On all frequencies between 764 to 776 MHz and 794 to 806 MHz, by a factor not less than $76 + 10 \log (P)$ dB in a 6.25 kHz band segment, for base and fixed stations.

Note: The Device has 4x4 MIMO function, so the limit of spurious emissions needs to be reduced by $10\log(\text{Numbers}_{\text{Ant}})$ according to FCC KDB 662911 D01 guidance.

{ $10\log(10\text{kHz}/6.25\text{kHz}) = 2.04\text{dB}$,

The limits is adjusted to $-46\text{dBm} + 2.04\text{dB} - 10*\log(4) = -49.98\text{dBm}$ }

Emissions in the band 1559-1610 MHz shall be limited to -70 dBW/MHz equivalent isotropically radiated power (EIRP) for wideband signals, and -80dBW EIRP for discrete emission of less than 700Hz bandwidth.

{The limits is adjusted to $-40\text{dBm} (-70\text{dBW}) - 10*\log(4) = -46.02\text{dBm}$ }

4.7.2 Test Setup

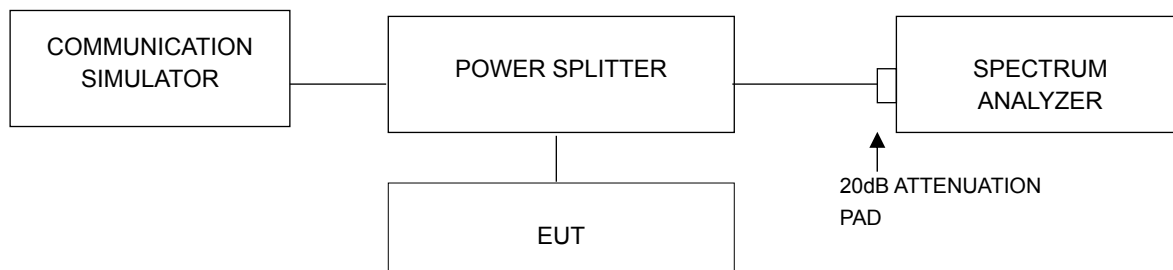

4.7.3 Test Procedure

- All measurements were done at 3 channels: low, middle and high operational frequency range.
- When the spectrum scanned from 9kHz to 26.5GHz, it shall be connected to the attenuator with the carried frequency.

4.7.4 Test Results

Single Mode (Chain 0)

Channel Band width: 5MHz

Channel 5205 (748.5MHz)

Frequency Range : 9kHz~763MHz

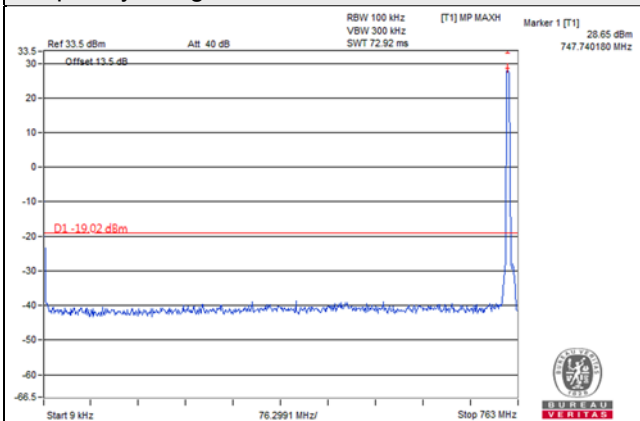

Frequency Range : 763MHz~775MHz

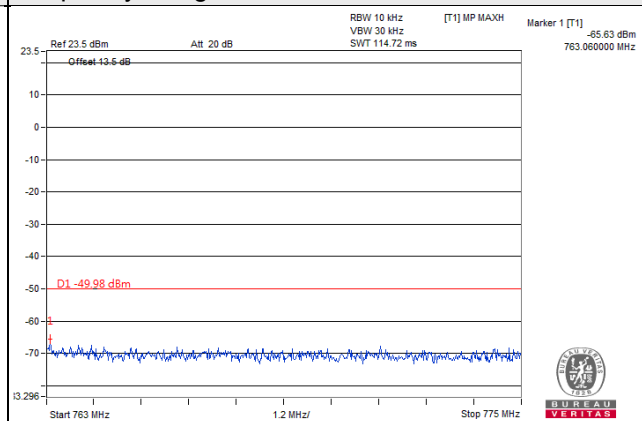

Frequency Range : 775MHz~793MHz

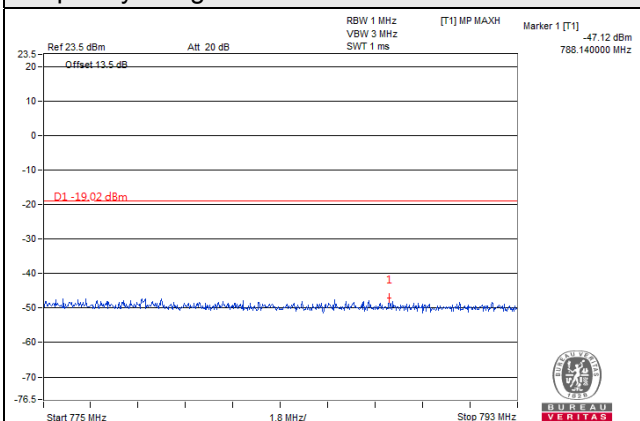

Frequency Range : 793MHz~805MHz

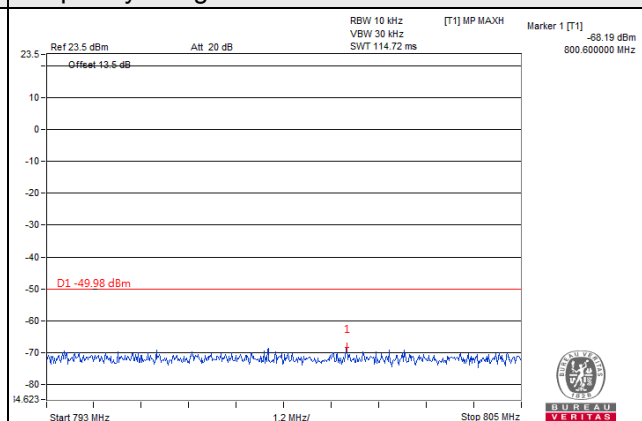

Frequency Range : 805MHz~1.559GHz

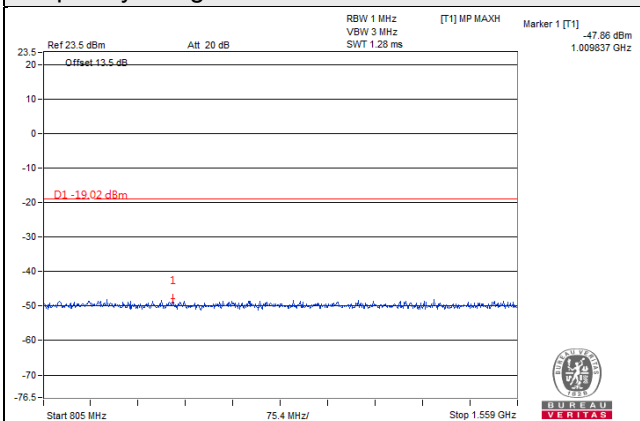

Frequency Range : 1.559GHz~1.610GHz

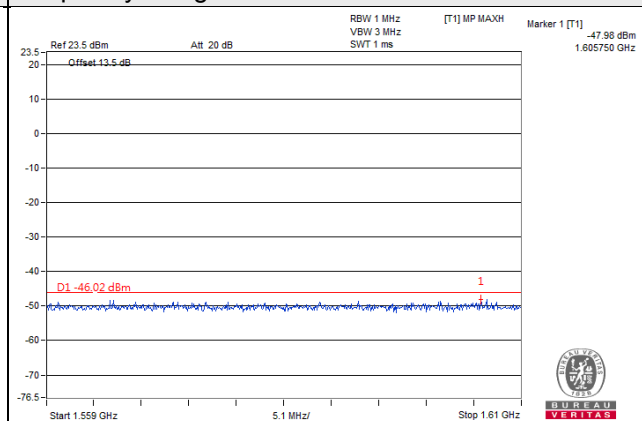

Frequency Range : 1.610GHz~9GHz

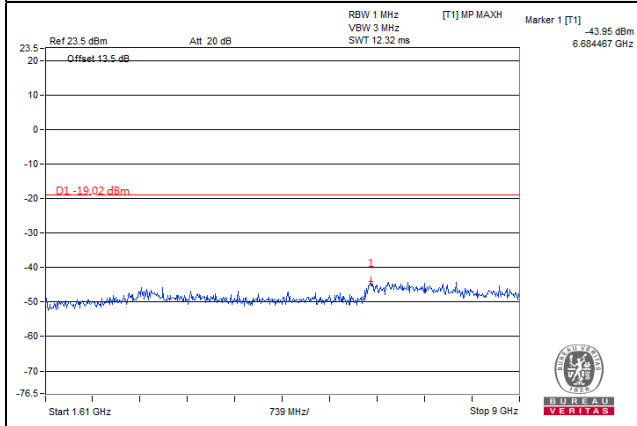

Channel Band width: 5MHz

Channel 5230 (751.0MHz)

Frequency Range : 9kHz~763MHz

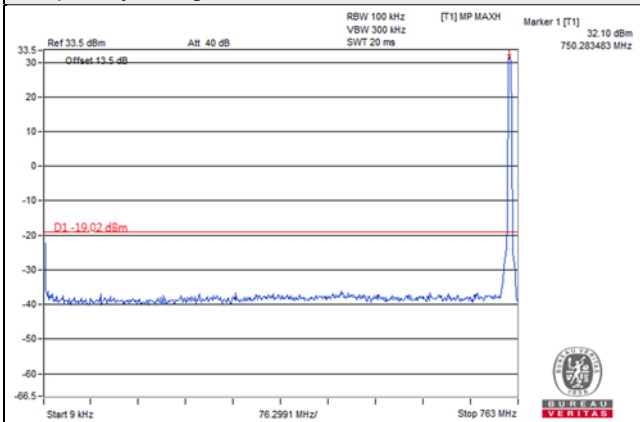

Frequency Range : 763MHz~775MHz

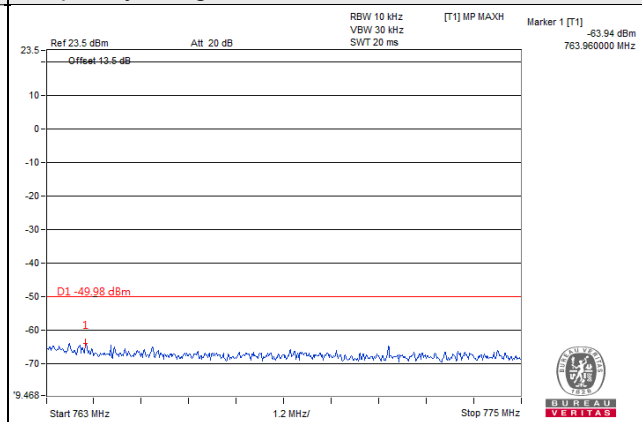

Frequency Range : 775MHz~793MHz

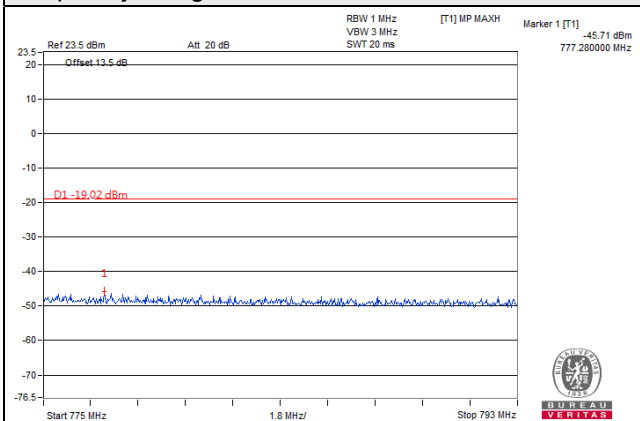

Frequency Range : 793MHz~805MHz

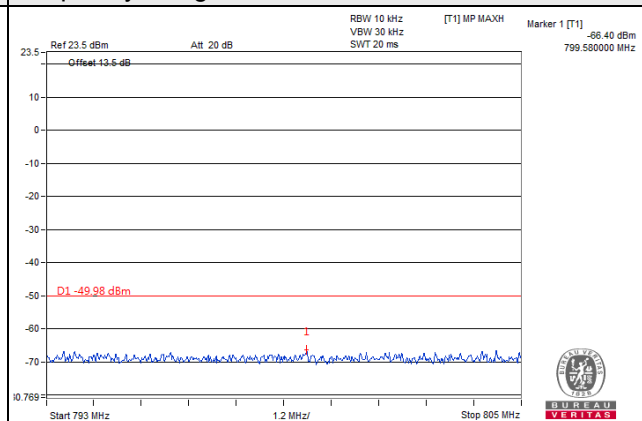

Frequency Range : 805MHz~1.559GHz

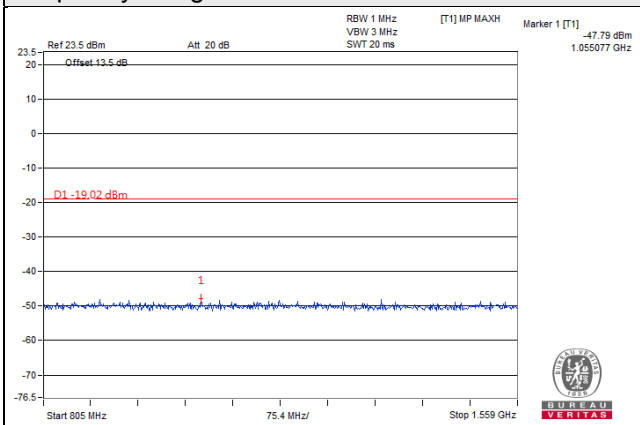

Frequency Range : 1.559GHz~1.610GHz

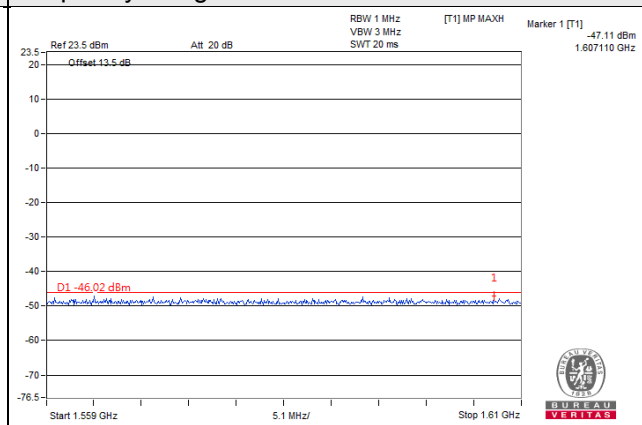

Frequency Range : 1.610GHz~9GHz

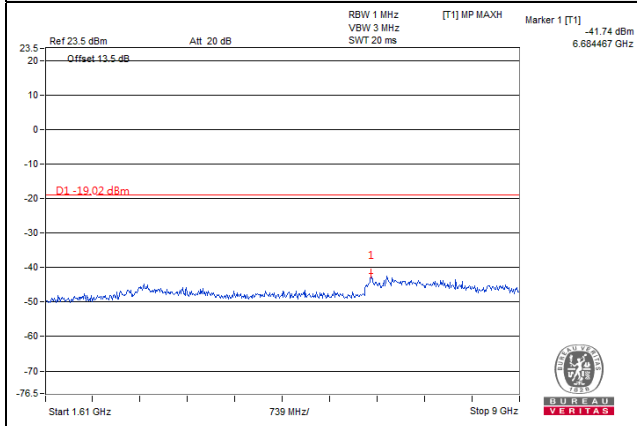

Channel Band width: 5MHz

Channel 5255 (753.5MHz)

Frequency Range : 9kHz~763MHz

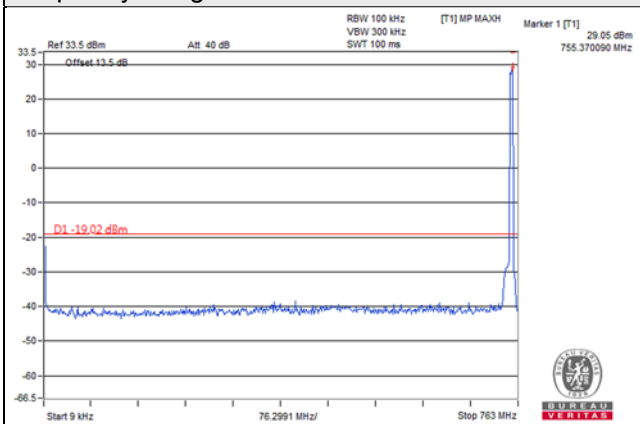

Frequency Range : 763MHz~775MHz

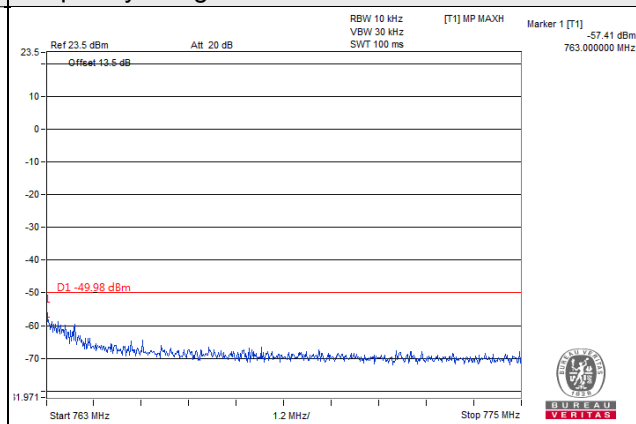

Frequency Range : 775MHz~793MHz

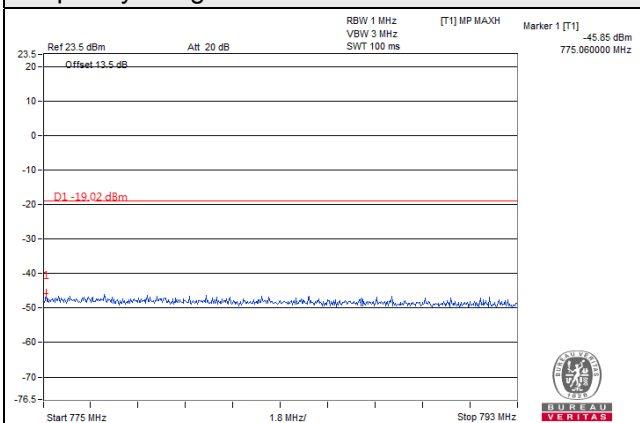

Frequency Range : 793MHz~805MHz

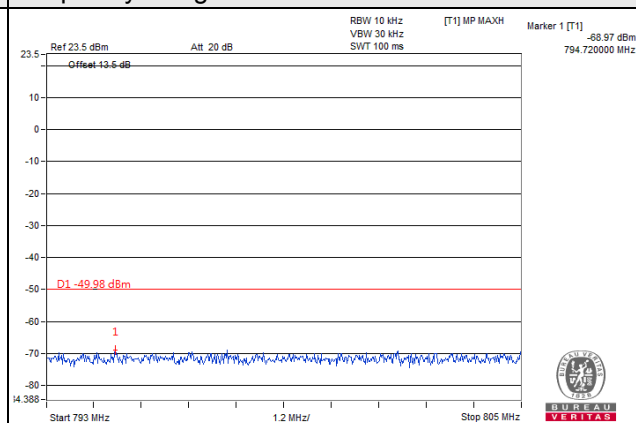

Frequency Range : 805MHz~1.559GHz

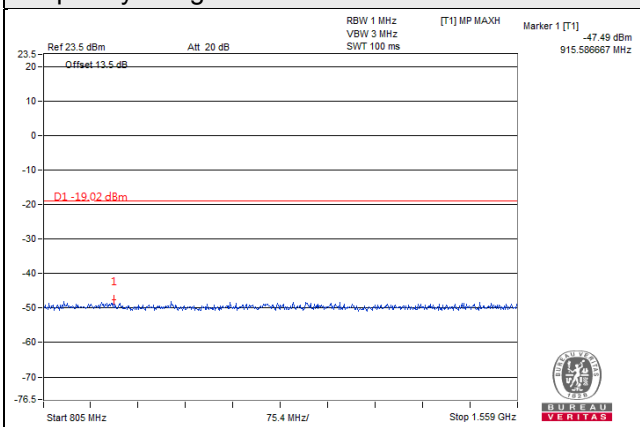

Frequency Range : 1.559GHz~1.610GHz

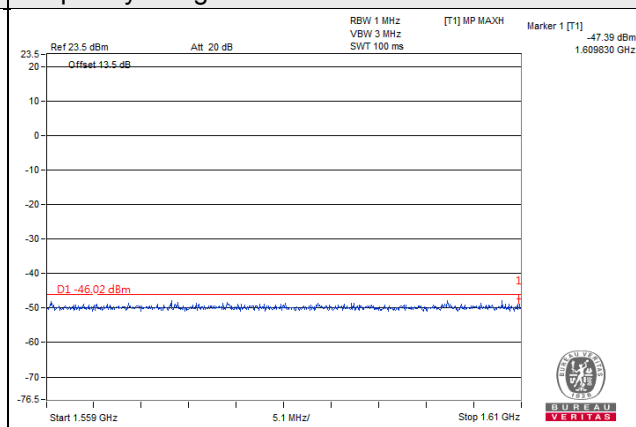

Frequency Range : 1.610GHz~9GHz

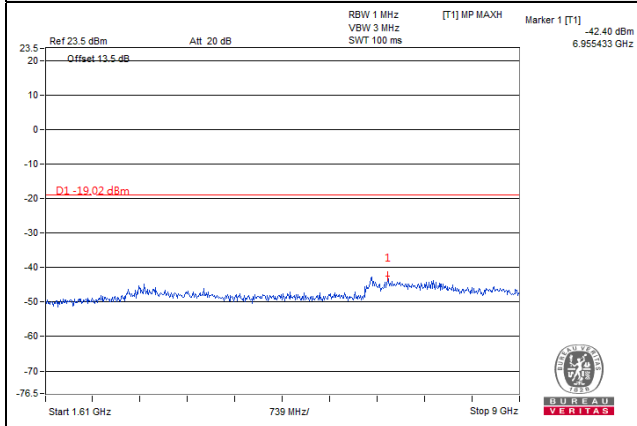

Channel Band width: 10MHz

Channel 5230 (751.0MHz)

Frequency Range : 9kHz~763MHz

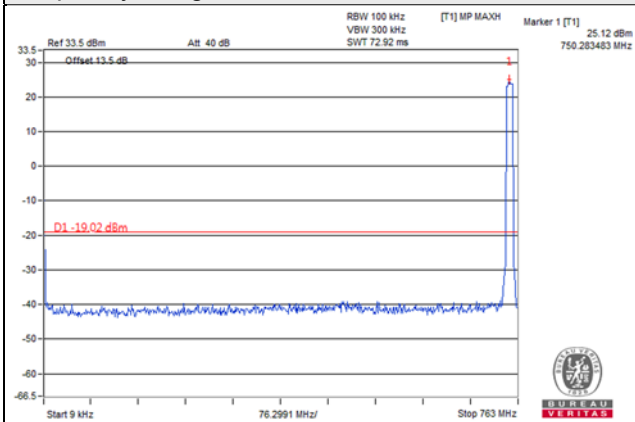

Frequency Range : 763MHz~775MHz

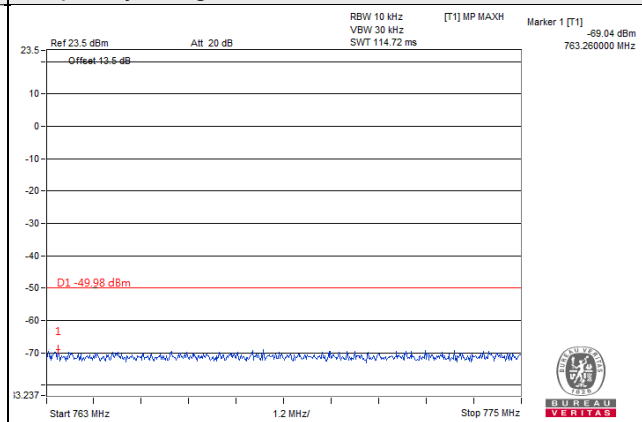

Frequency Range : 775MHz~793MHz

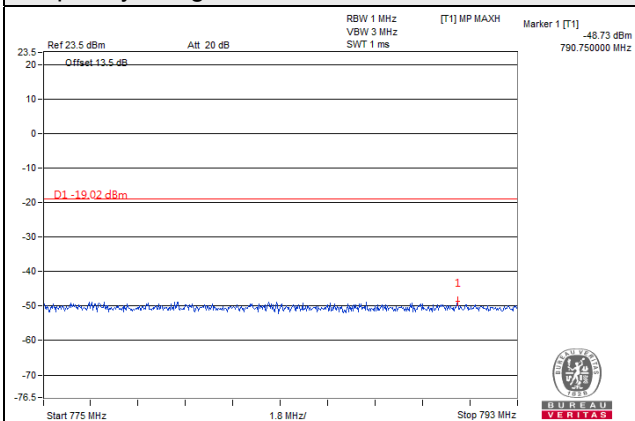

Frequency Range : 793MHz~805MHz

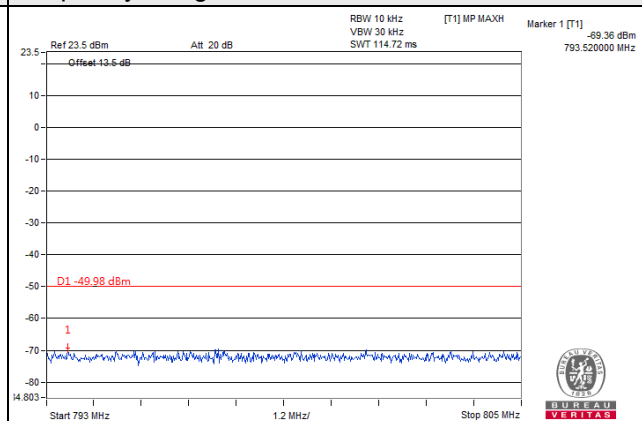

Frequency Range : 805MHz~1.559GHz

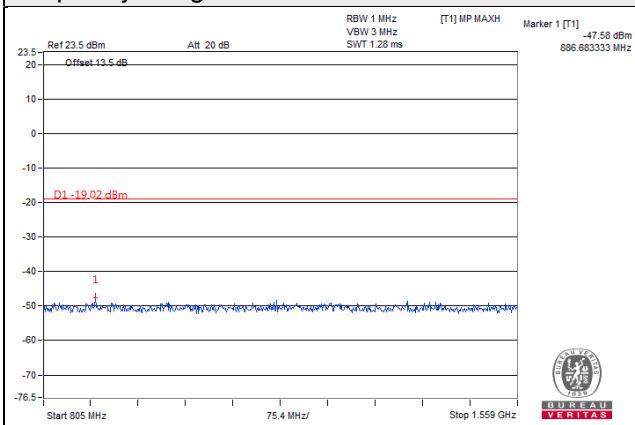

Frequency Range : 1.559GHz~1.610GHz

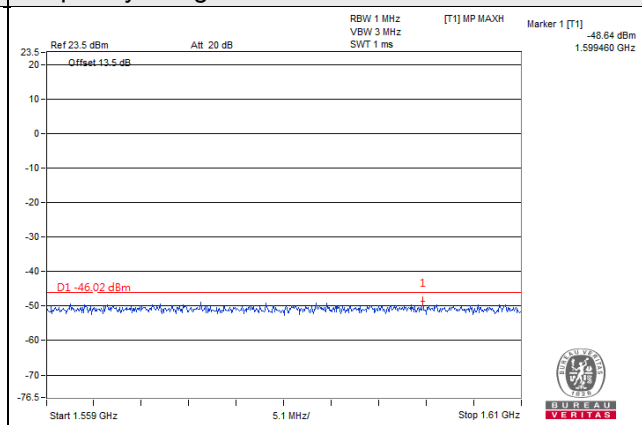

Frequency Range : 1.610GHz~9GHz

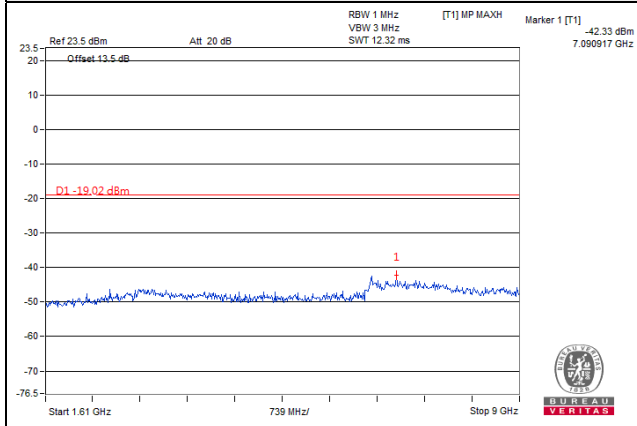

Single Mode (Chain 1)

Channel Band width: 5MHz

Channel 5205 (748.5MHz)

Frequency Range : 9kHz~763MHz

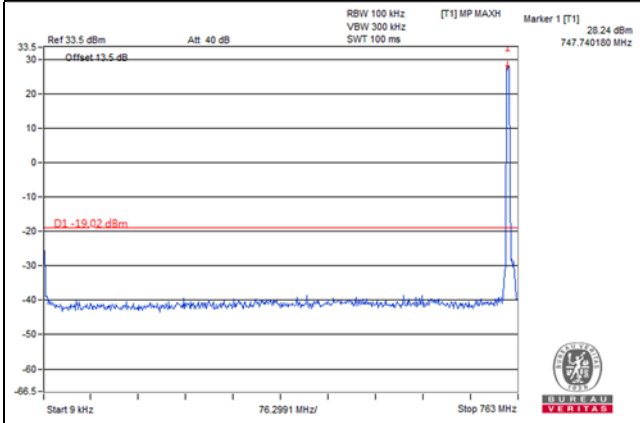

Frequency Range : 763MHz~775MHz

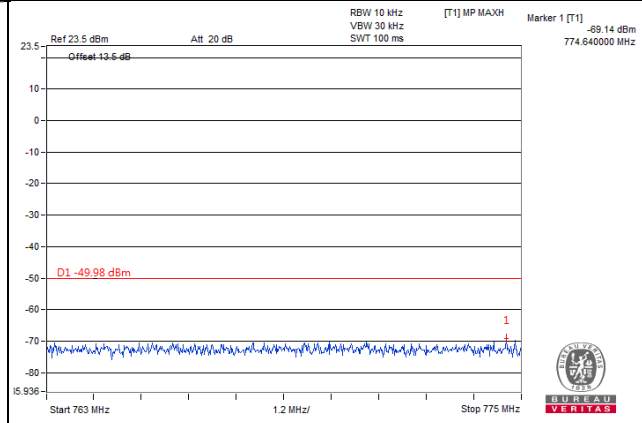

Frequency Range : 775MHz~793MHz

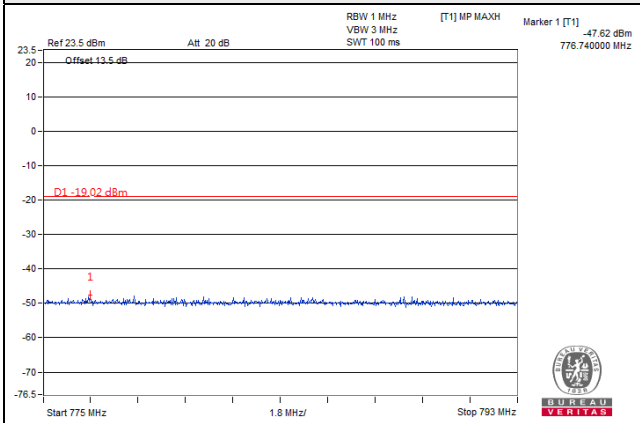

Frequency Range : 793MHz~805MHz

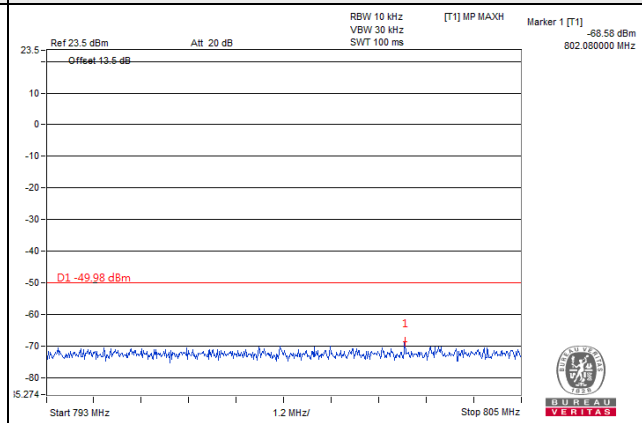

Frequency Range : 805MHz~1.559GHz

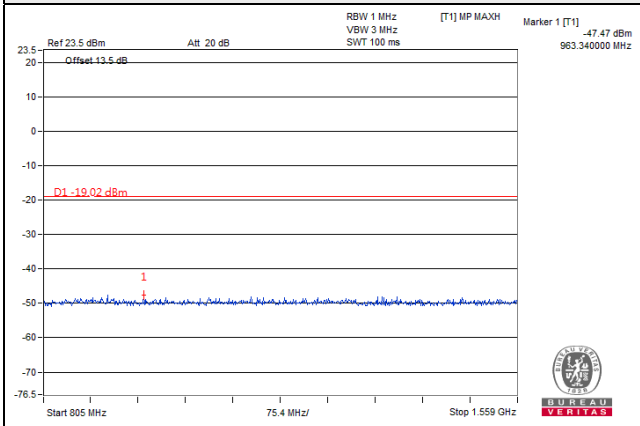

Frequency Range : 1.559GHz~1.610GHz

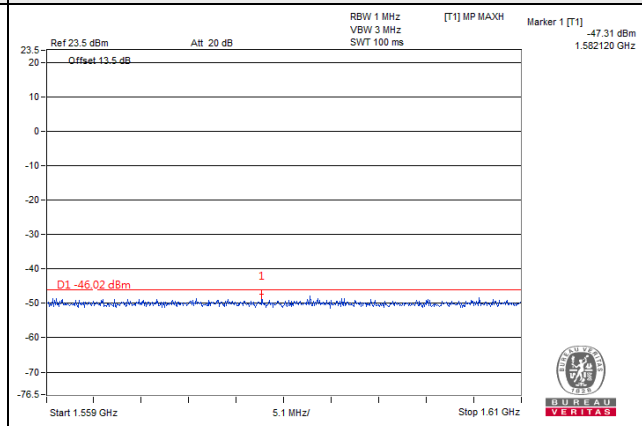

Frequency Range : 1.610GHz~9GHz

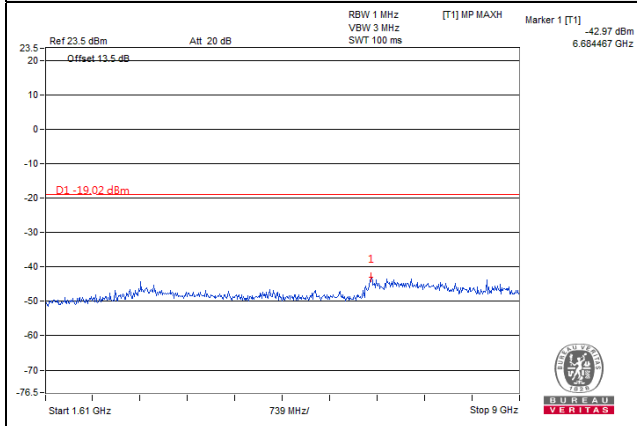

Channel Band width: 5MHz

Channel 5230 (751.0MHz)

Frequency Range : 9kHz~763MHz

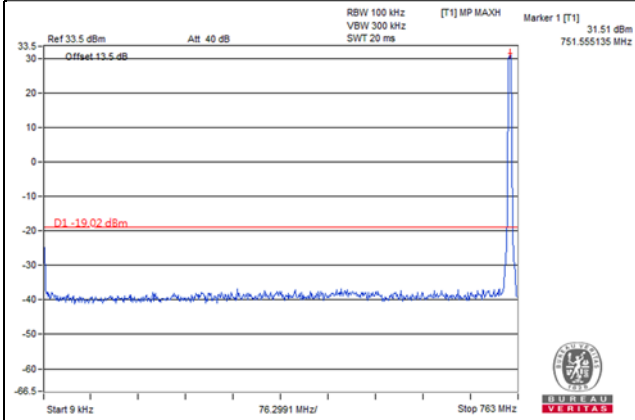

Frequency Range : 763MHz~775MHz

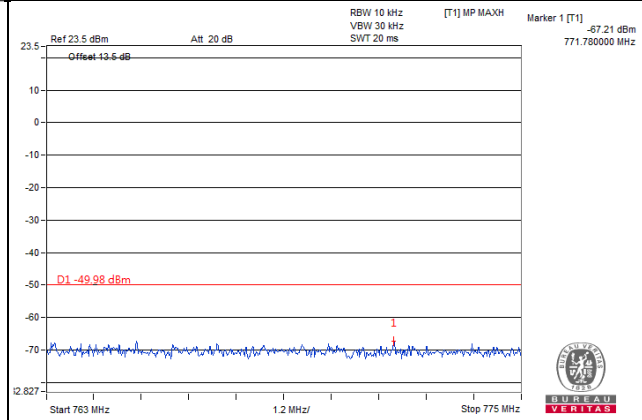

Frequency Range : 775MHz~793MHz

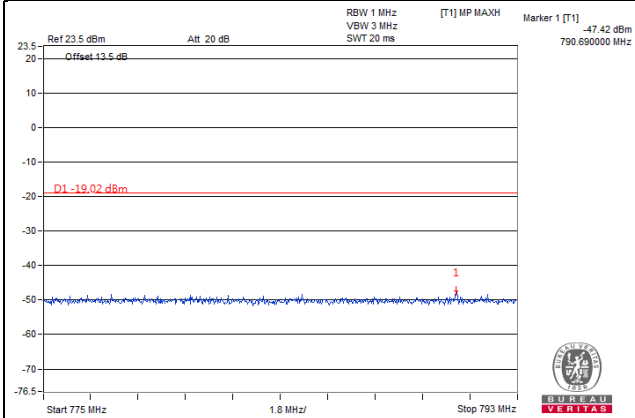

Frequency Range : 793MHz~805MHz

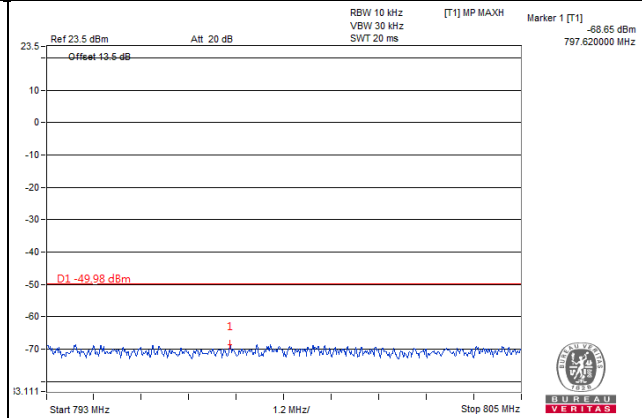

Frequency Range : 805MHz~1.559GHz

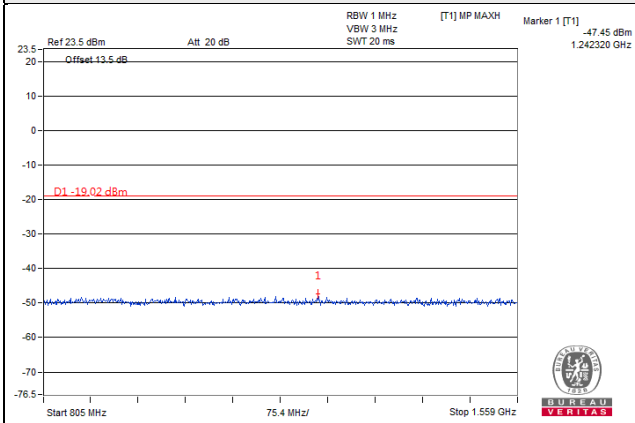

Frequency Range : 1.559GHz~1.610GHz

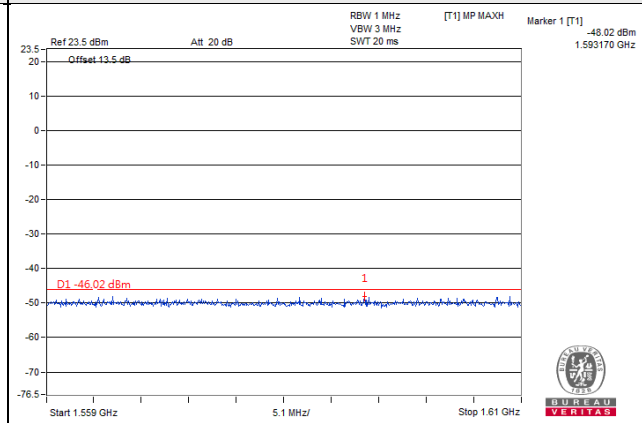

Frequency Range : 1.610GHz~9GHz

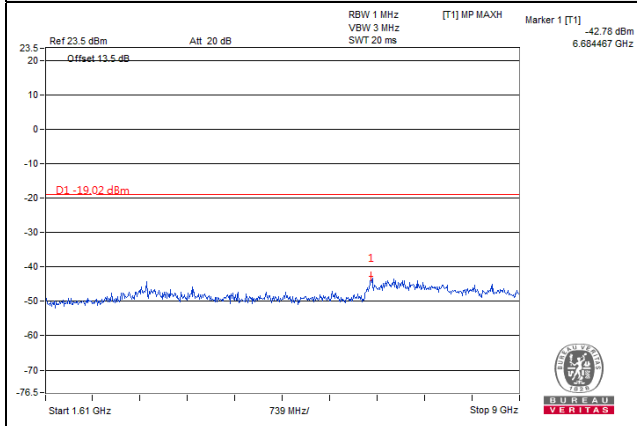

Channel Band width: 5MHz

Channel 5255 (753.5MHz)

Frequency Range : 9kHz~763MHz

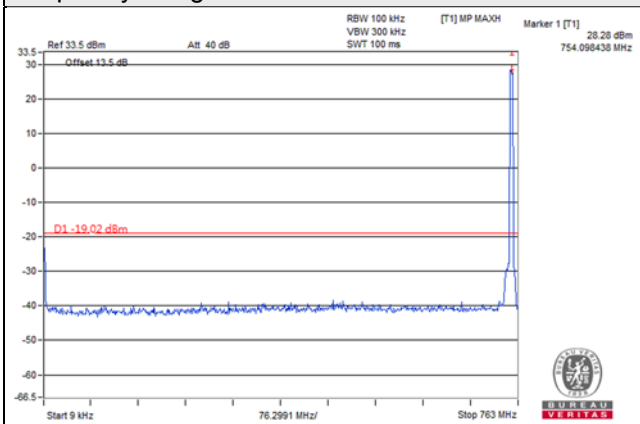

Frequency Range : 763MHz~775MHz

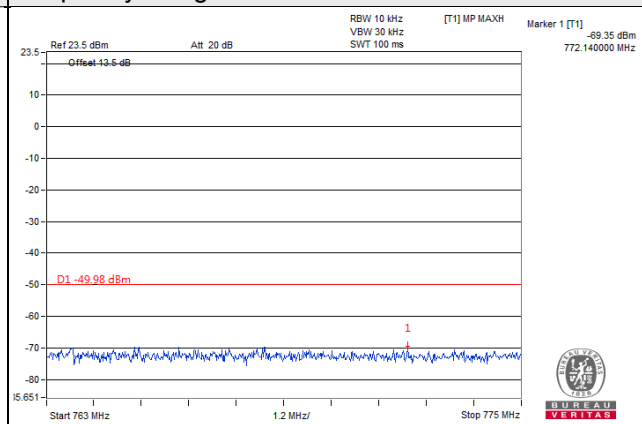

Frequency Range : 775MHz~793MHz

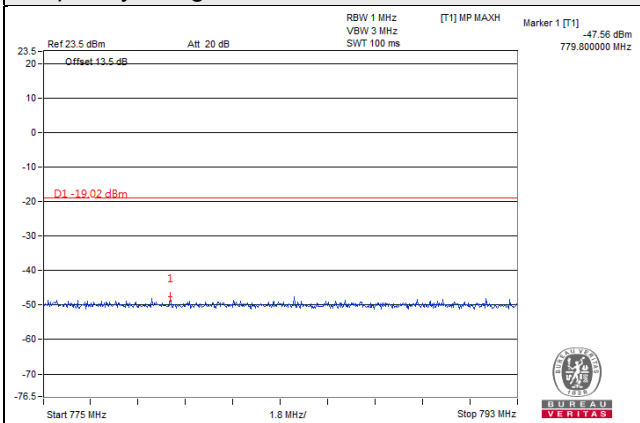

Frequency Range : 793MHz~805MHz

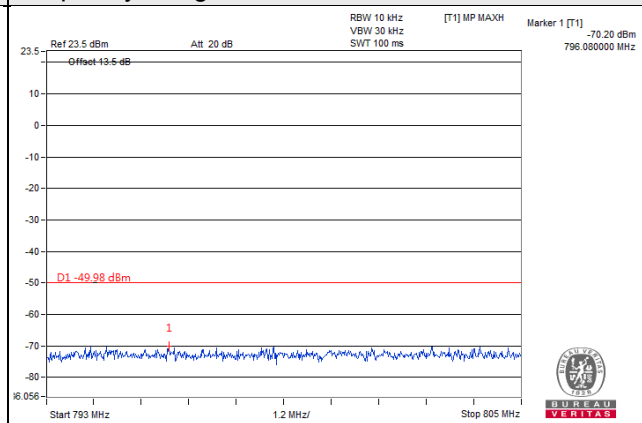

Frequency Range : 805MHz~1.559GHz

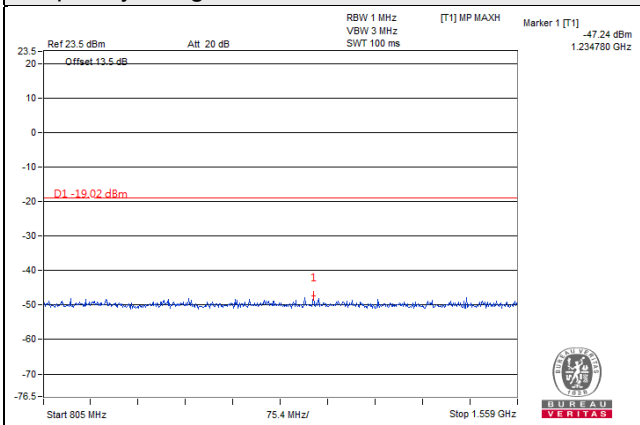

Frequency Range : 1.559GHz~1.610GHz

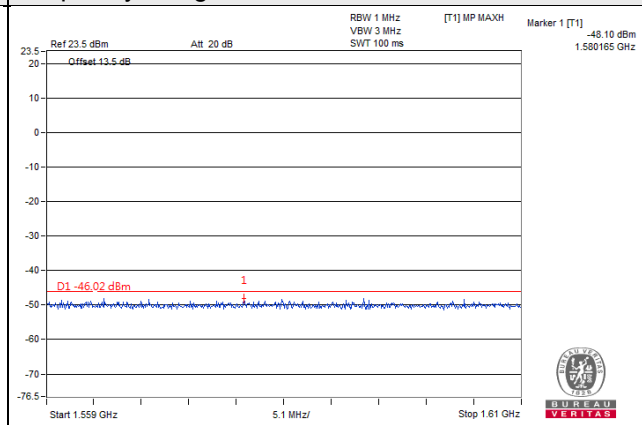

Frequency Range : 1.610GHz~9GHz

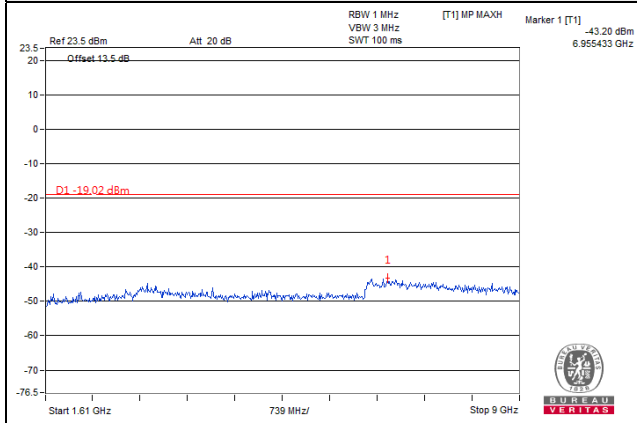

Channel Band width: 10MHz

Channel 5230 (751.0MHz)

Frequency Range : 9kHz~763MHz

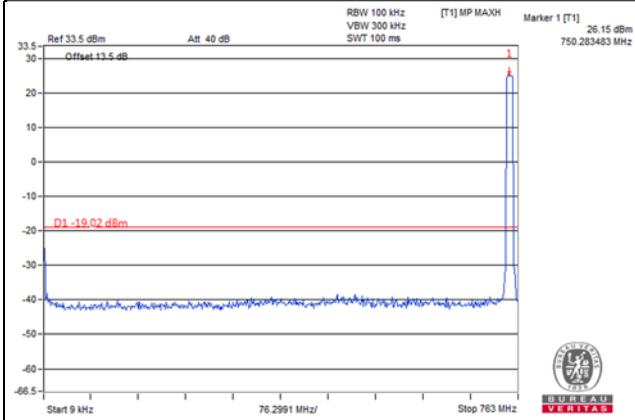

Frequency Range : 763MHz~775MHz

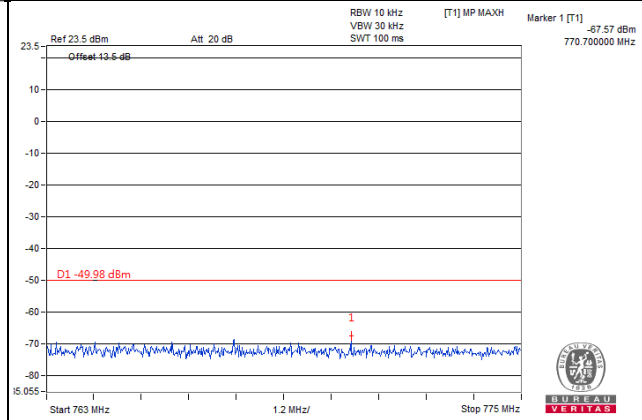

Frequency Range : 775MHz~793MHz

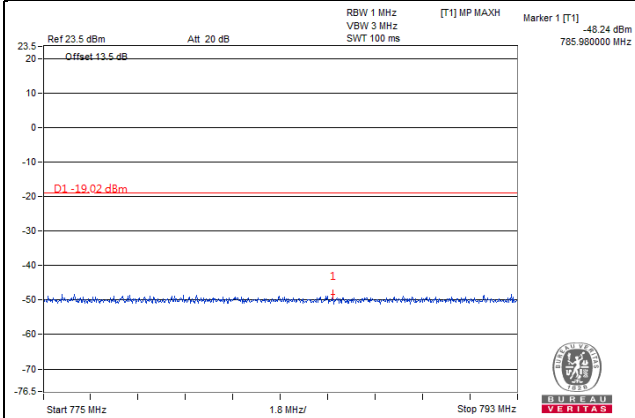

Frequency Range : 793MHz~805MHz

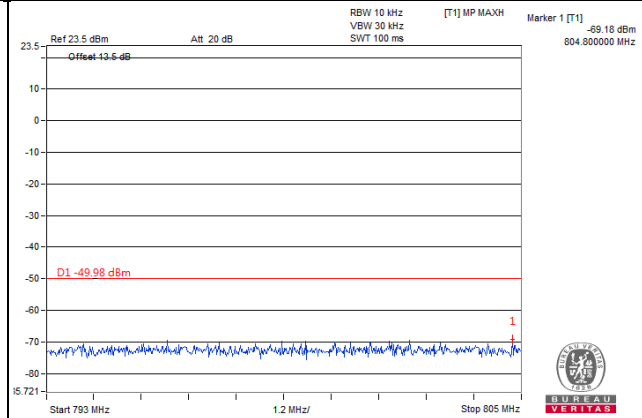

Frequency Range : 805MHz~1.559GHz

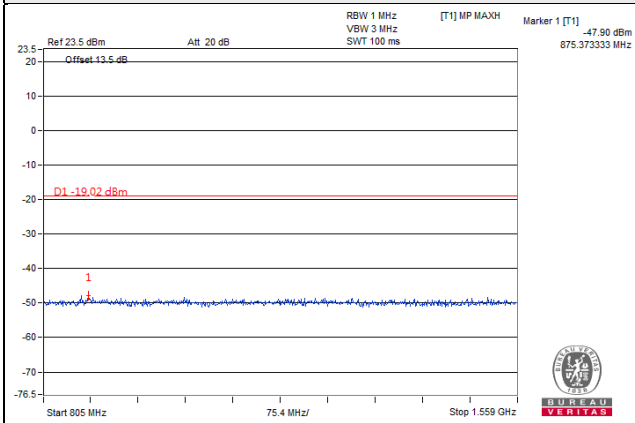

Frequency Range : 1.559GHz~1.610GHz

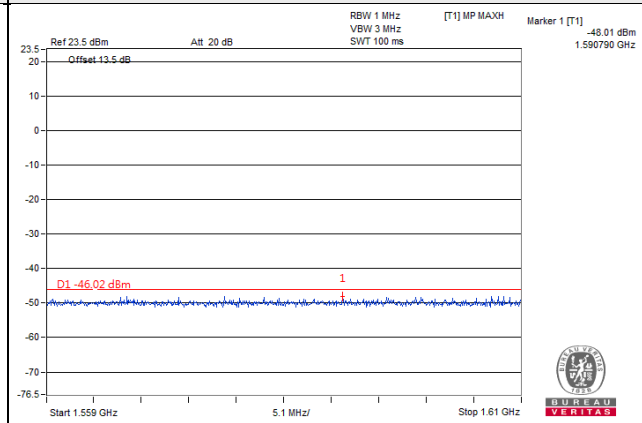

Frequency Range : 1.610GHz~9GHz

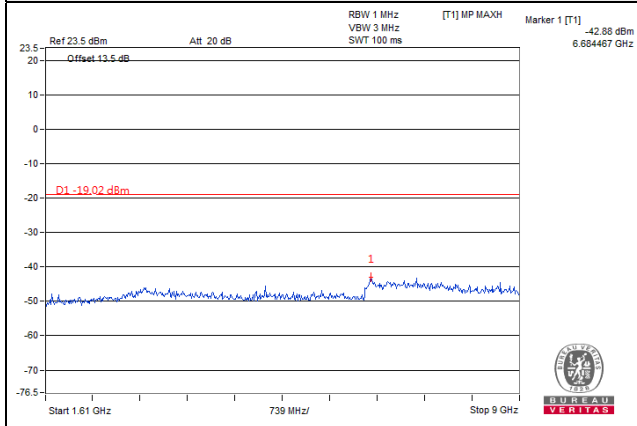

Single Mode (Chain 2)

Channel Band width: 5MHz

Channel 5205 (748.5MHz)

Frequency Range : 9kHz~763MHz

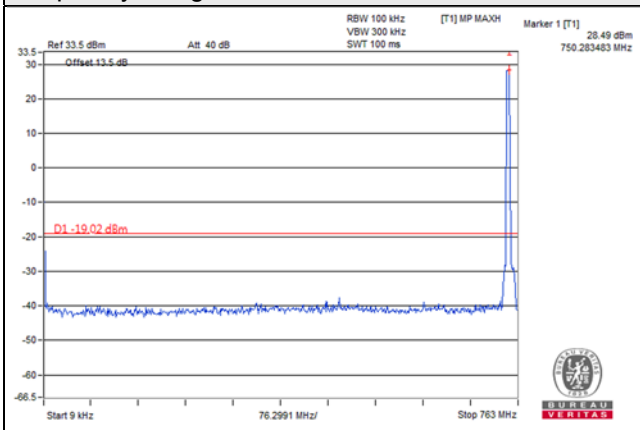

Frequency Range : 763MHz~775MHz

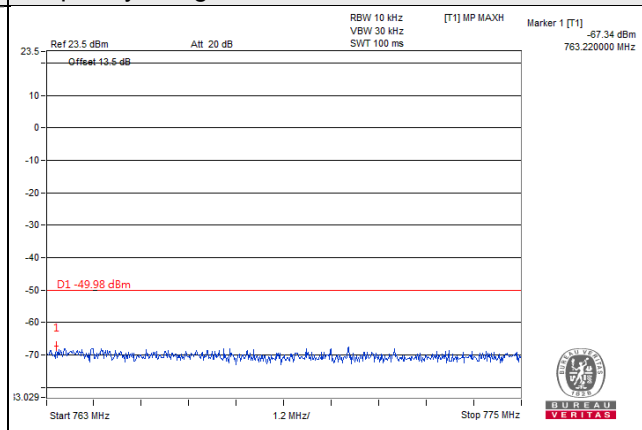

Frequency Range : 775MHz~793MHz

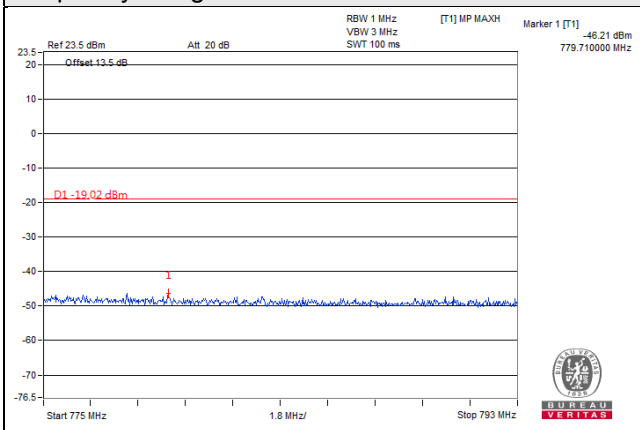

Frequency Range : 793MHz~805MHz

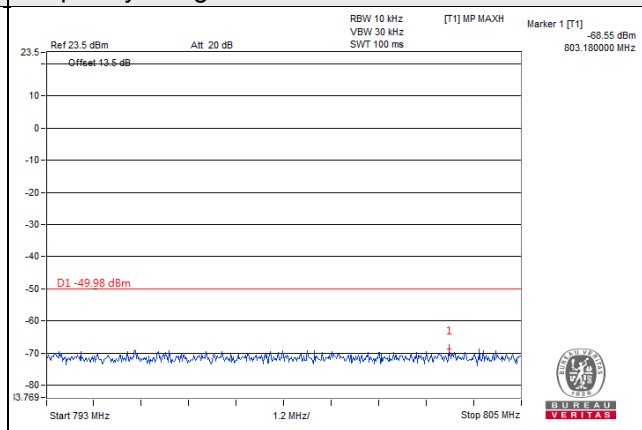

Frequency Range : 805MHz~1.559GHz

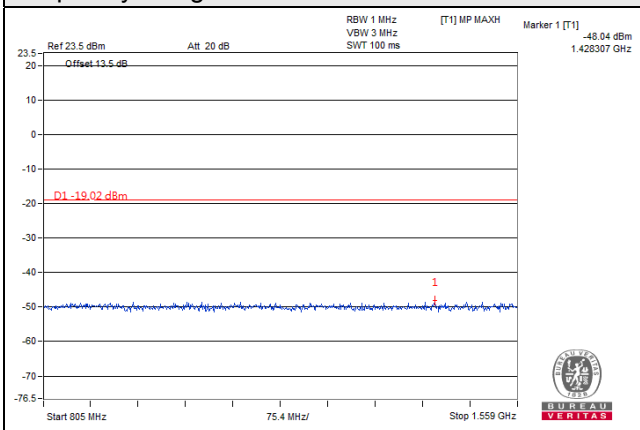

Frequency Range : 1.559GHz~1.610GHz

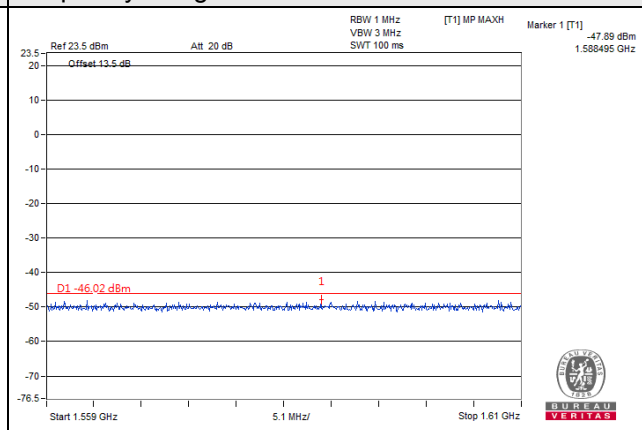

Frequency Range : 1.610GHz~9GHz

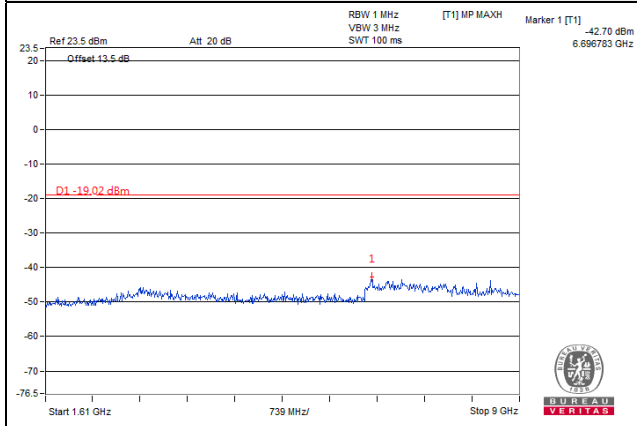

Channel Band width: 5MHz

Channel 5230 (751.0MHz)

Frequency Range : 9kHz~763MHz

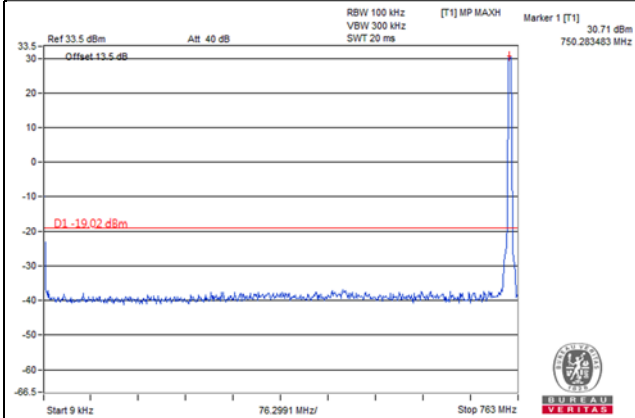

Frequency Range : 763MHz~775MHz

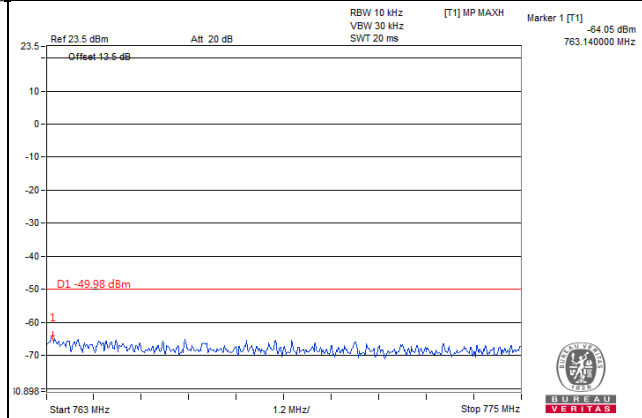

Frequency Range : 775MHz~793MHz

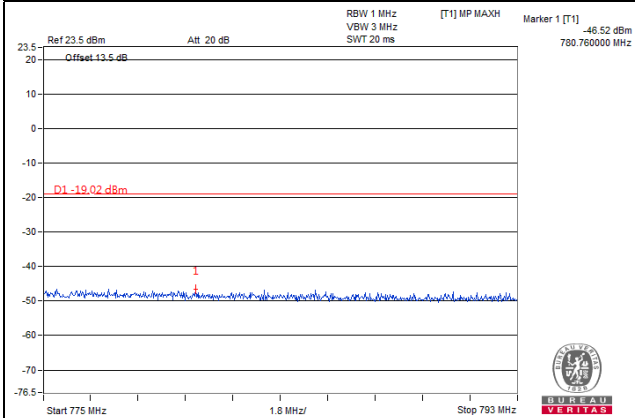

Frequency Range : 793MHz~805MHz

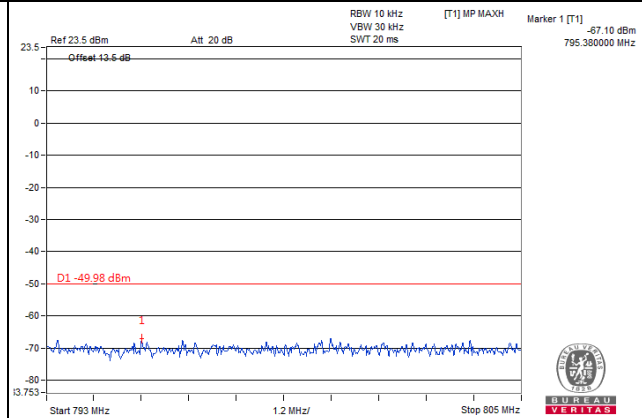

Frequency Range : 805MHz~1.559GHz

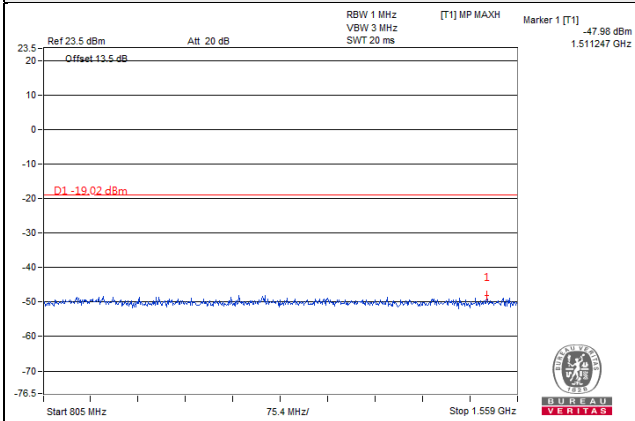

Frequency Range : 1.559GHz~1.610GHz

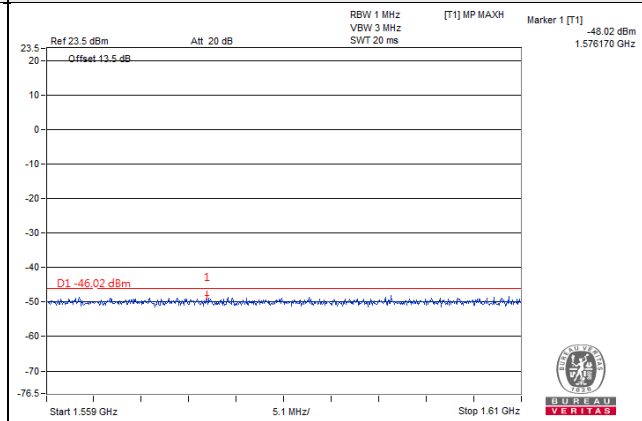

Frequency Range : 1.610GHz~9GHz

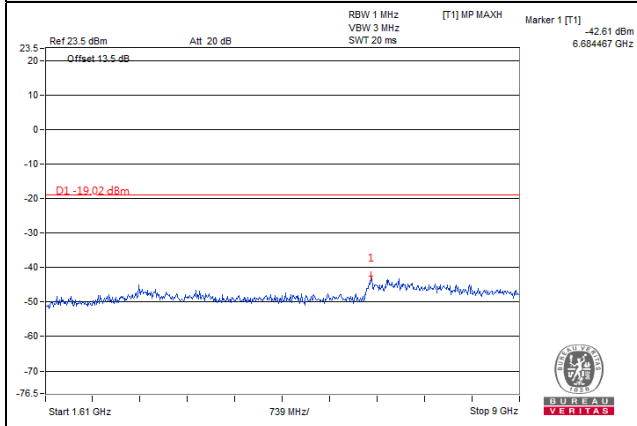

Channel Band width: 5MHz

Channel 5255 (753.5MHz)

Frequency Range : 9kHz~763MHz

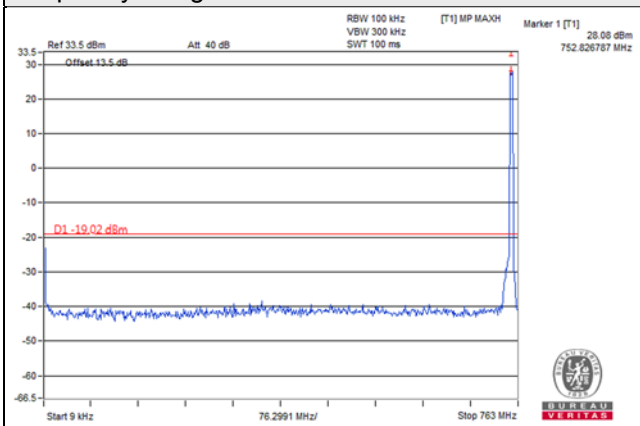

Frequency Range : 763MHz~775MHz

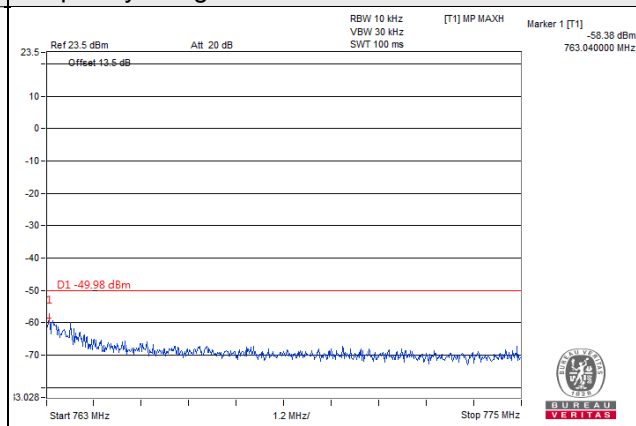

Frequency Range : 775MHz~793MHz

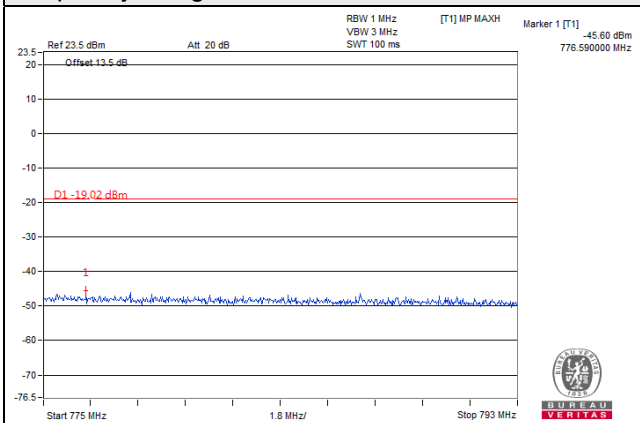

Frequency Range : 793MHz~805MHz

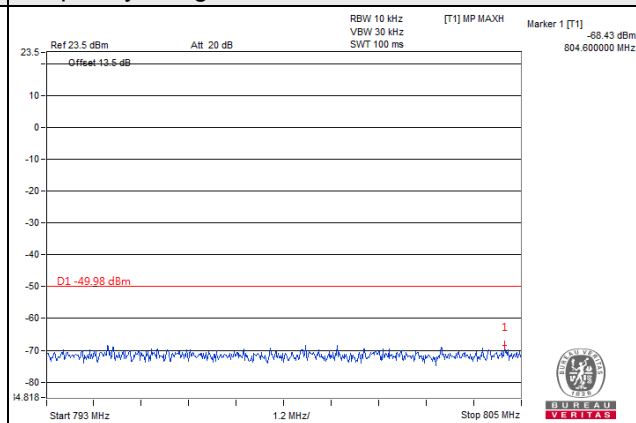

Frequency Range : 805MHz~1.559GHz

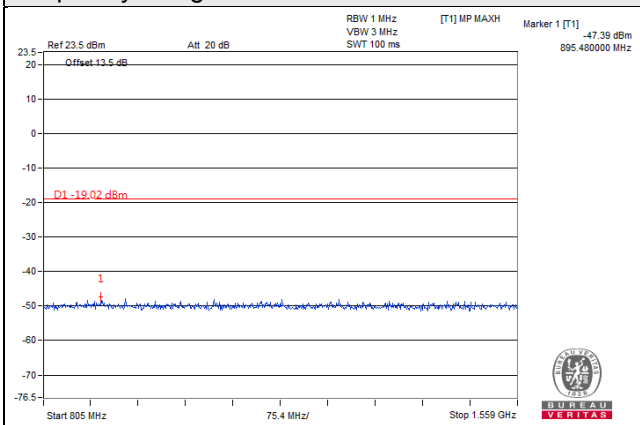

Frequency Range : 1.559GHz~1.610GHz

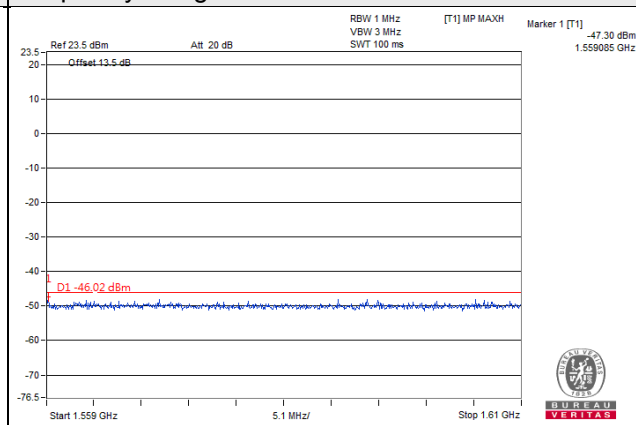

Frequency Range : 1.610GHz~9GHz

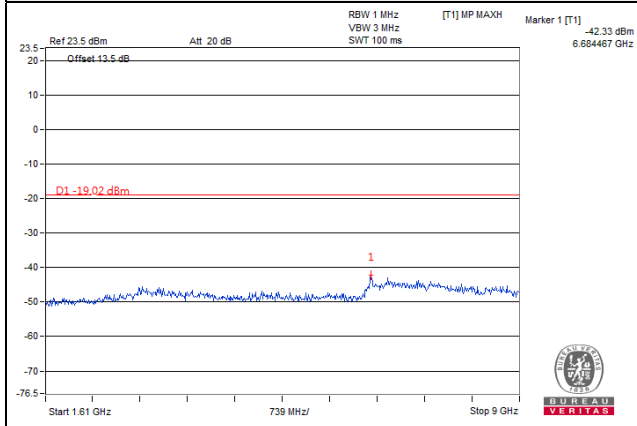

Channel Band width: 10MHz

Channel 5230 (751.0MHz)

Frequency Range : 9kHz~763MHz

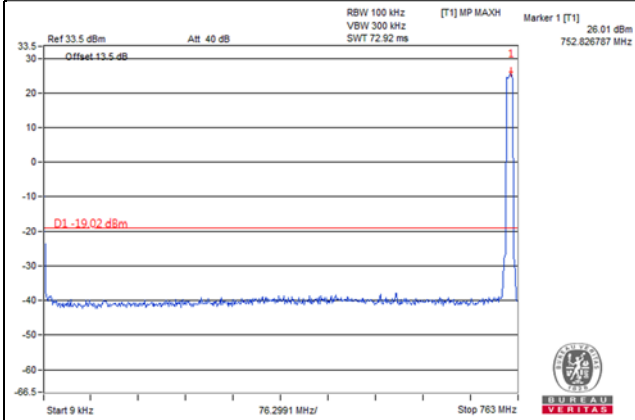

Frequency Range : 763MHz~775MHz

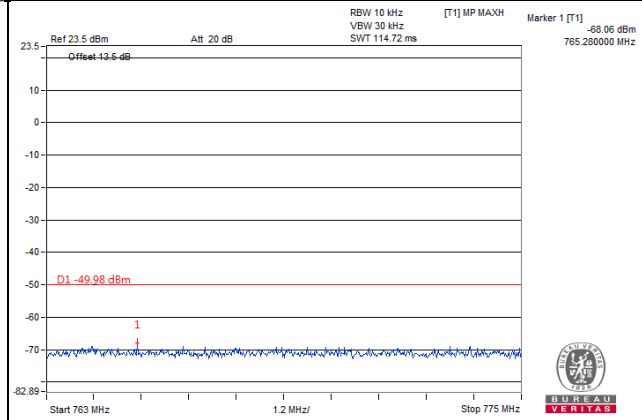

Frequency Range : 775MHz~793MHz

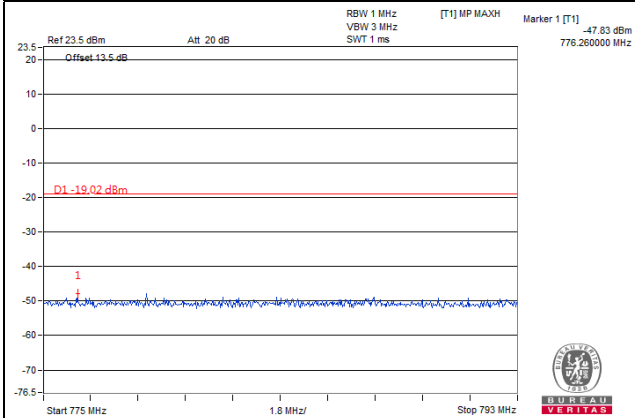

Frequency Range : 793MHz~805MHz

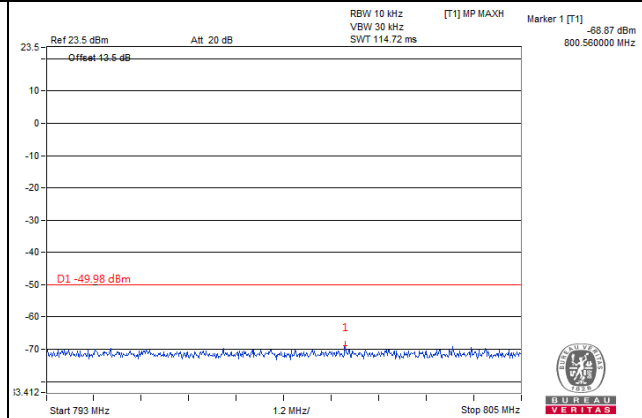

Frequency Range : 805MHz~1.559GHz

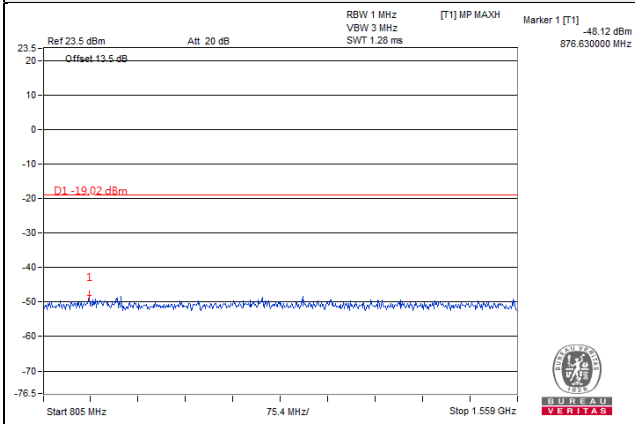

Frequency Range : 1.559GHz~1.610GHz

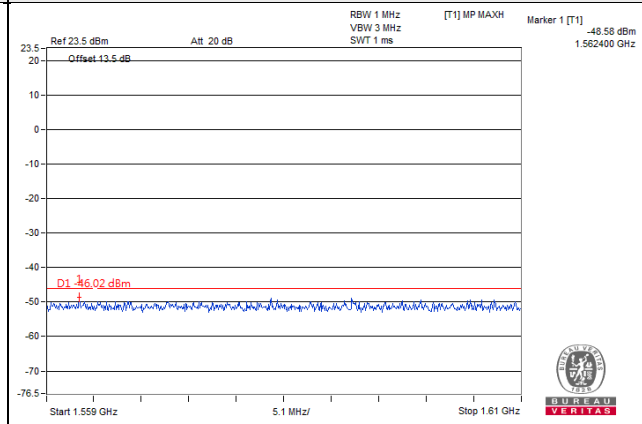

Frequency Range : 1.610GHz~9GHz

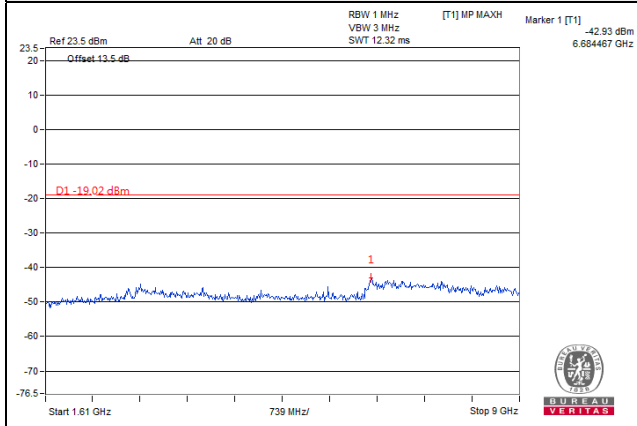

Single Mode (Chain 3)

Channel Band width: 5MHz

Channel 5205 (748.5MHz)

Frequency Range : 9kHz~763MHz

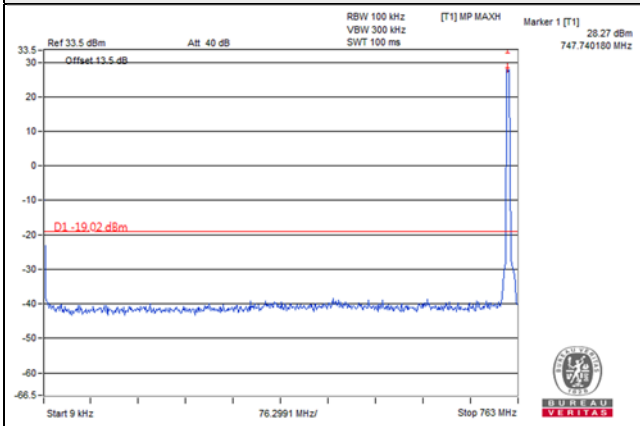

Frequency Range : 763MHz~775MHz

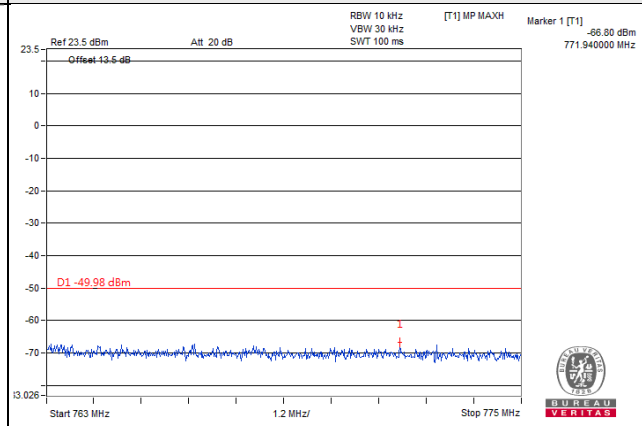

Frequency Range : 775MHz~793MHz

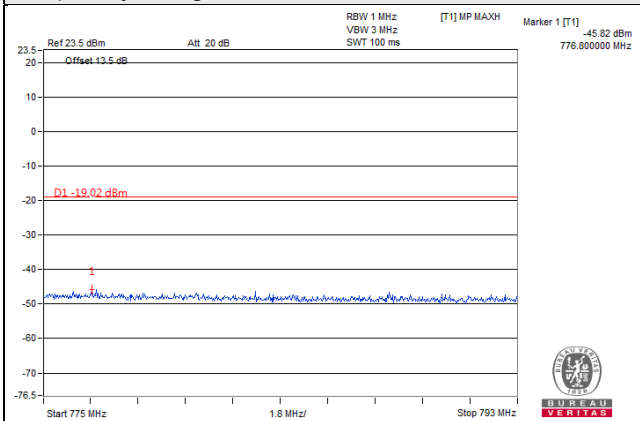

Frequency Range : 793MHz~805MHz

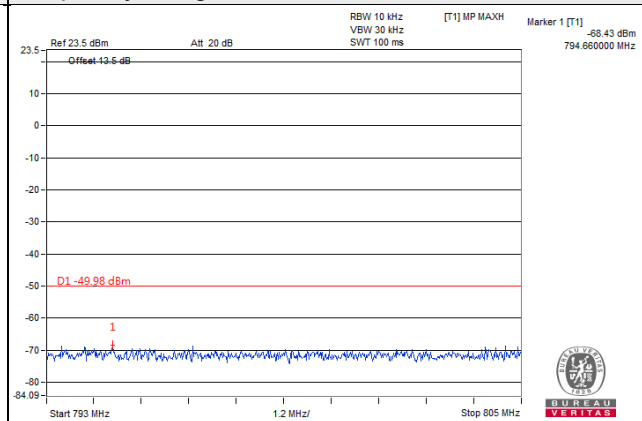

Frequency Range : 805MHz~1.559GHz

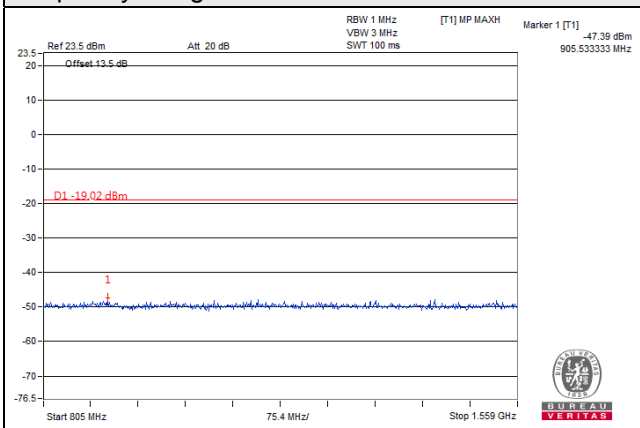

Frequency Range : 1.559GHz~1.610GHz

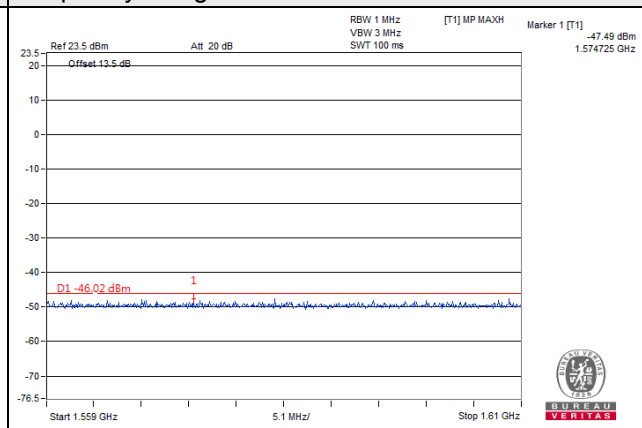

Frequency Range : 1.610GHz~9GHz

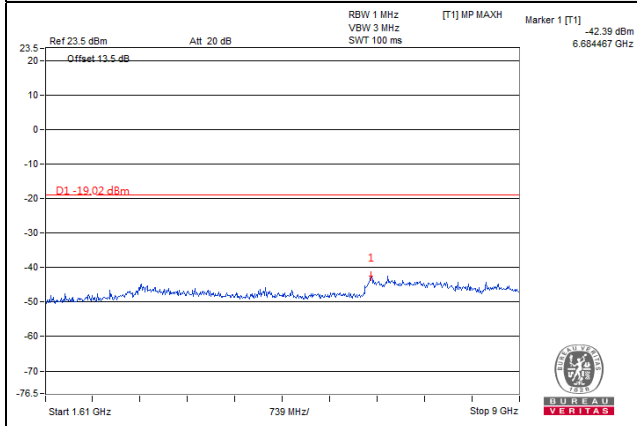

Channel Band width: 5MHz

Channel 5230 (751.0MHz)

Frequency Range : 9kHz~763MHz

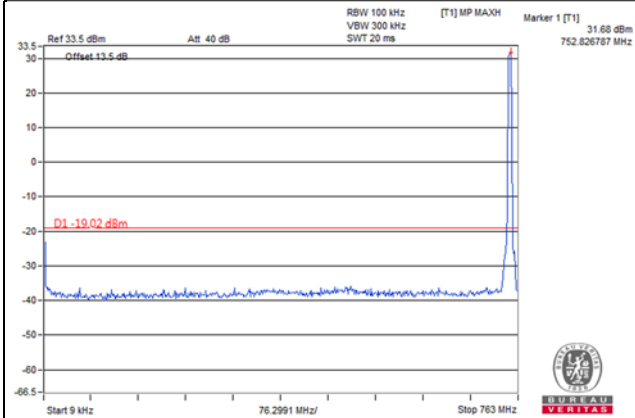

Frequency Range : 763MHz~775MHz

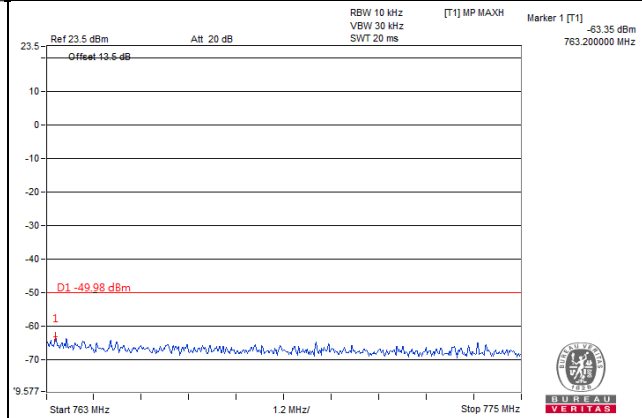

Frequency Range : 775MHz~793MHz

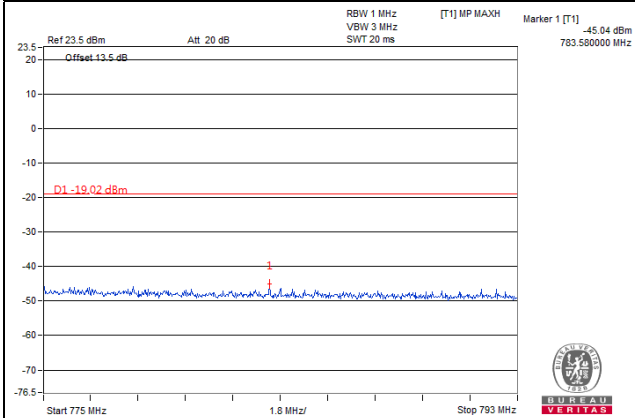

Frequency Range : 793MHz~805MHz

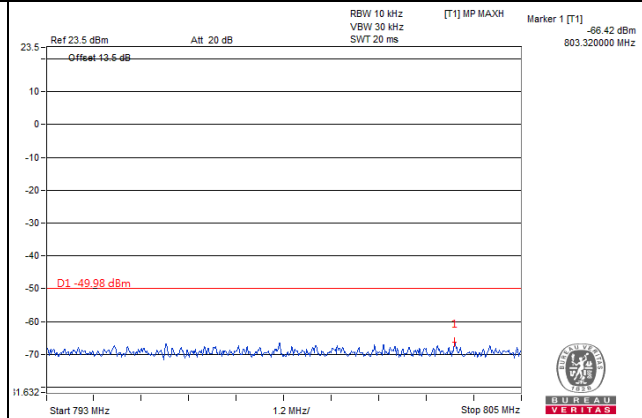

Frequency Range : 805MHz~1.559GHz

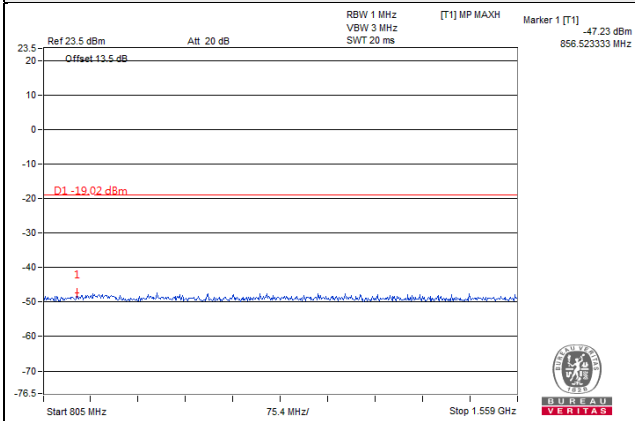

Frequency Range : 1.559GHz~1.610GHz

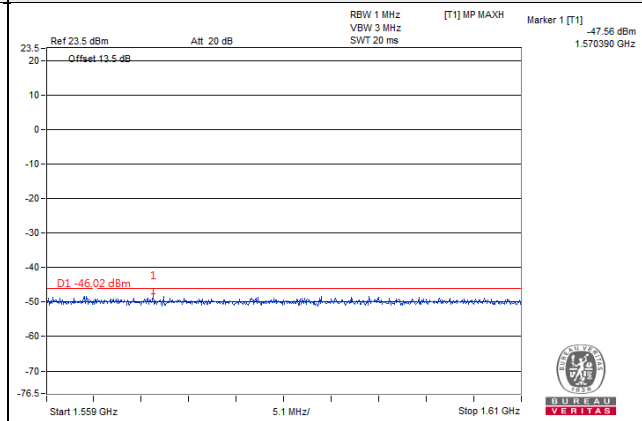

Frequency Range : 1.610GHz~9GHz

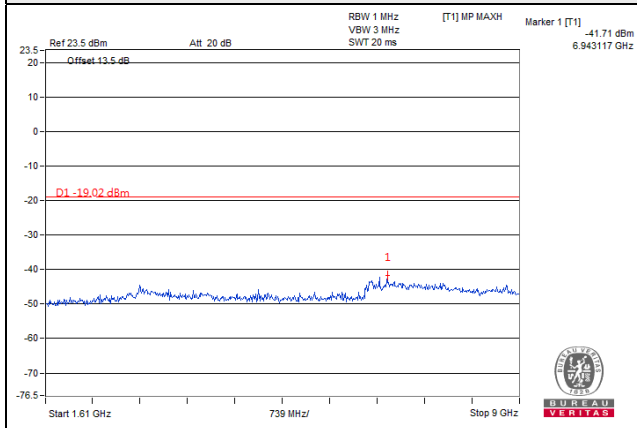

Channel Band width: 5MHz

Channel 5255 (753.5MHz)

Frequency Range : 9kHz~763MHz

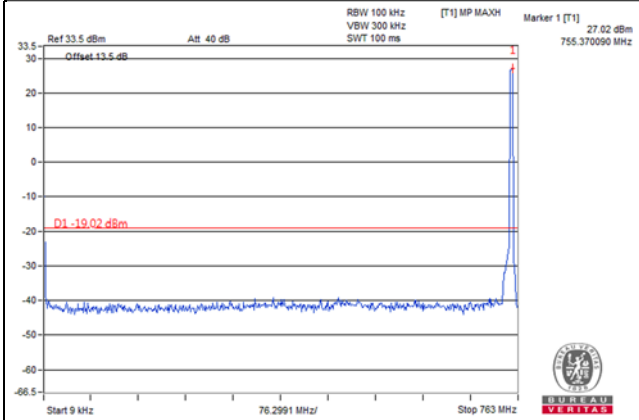

Frequency Range : 763MHz~775MHz

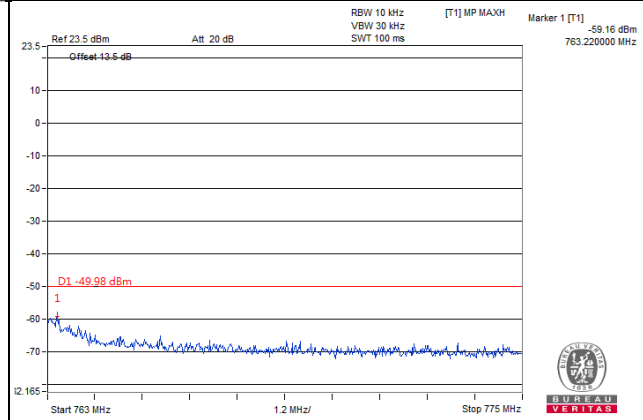

Frequency Range : 775MHz~793MHz

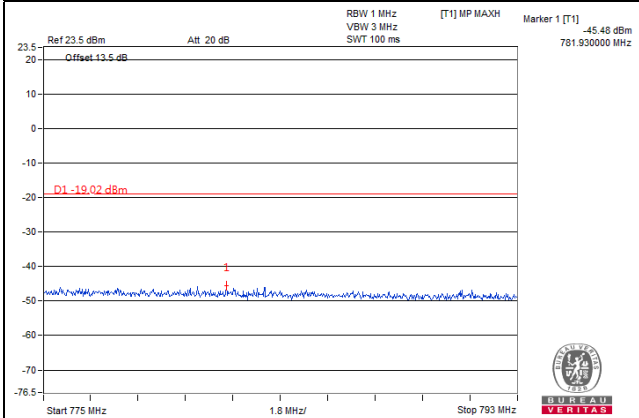

Frequency Range : 793MHz~805MHz

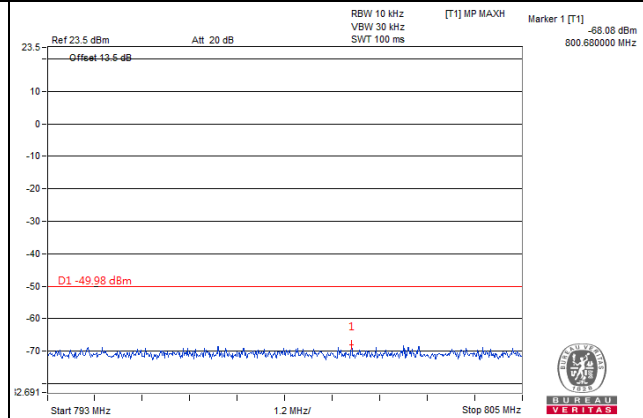

Frequency Range : 805MHz~1.559GHz

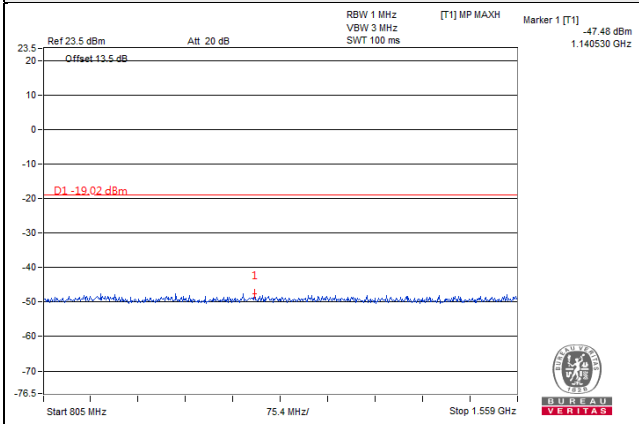

Frequency Range : 1.559GHz~1.610GHz

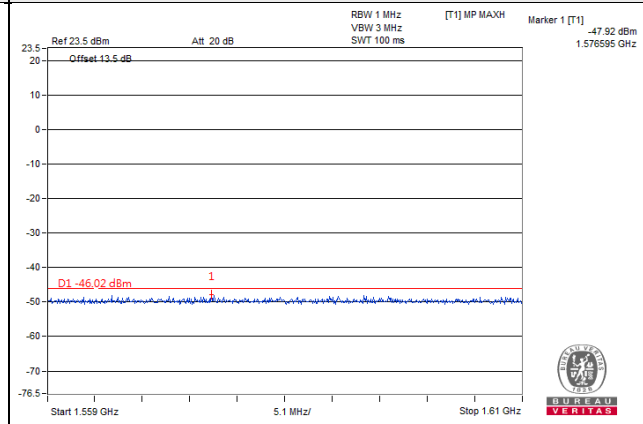

Frequency Range : 1.610GHz~9GHz

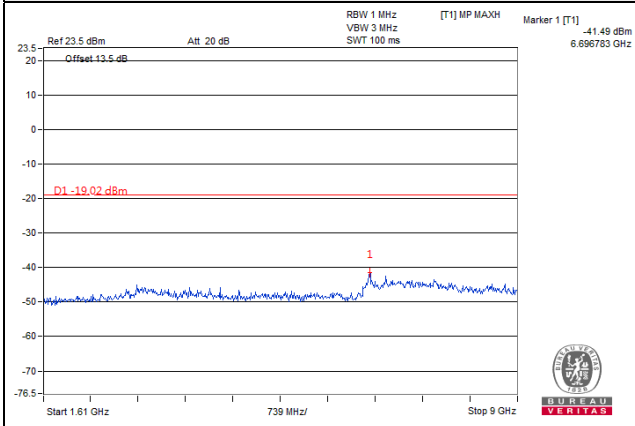

Channel Band width: 10MHz

Channel 5230 (751.0MHz)

Frequency Range : 9kHz~763MHz

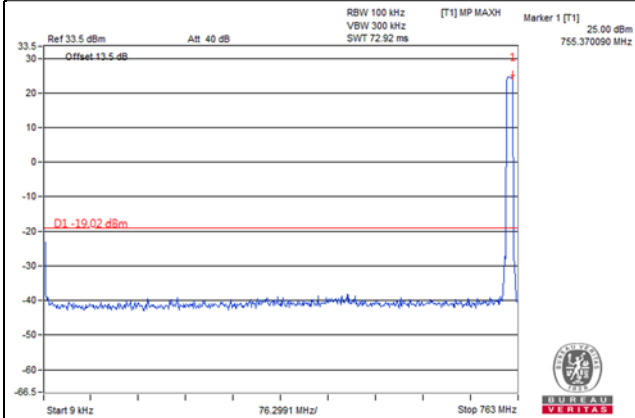

Frequency Range : 763MHz~775MHz

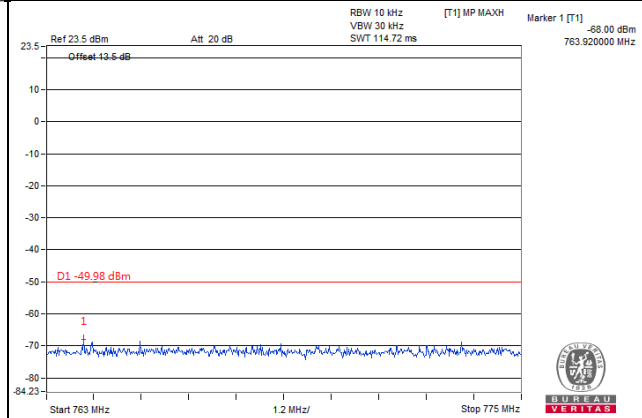

Frequency Range : 775MHz~793MHz

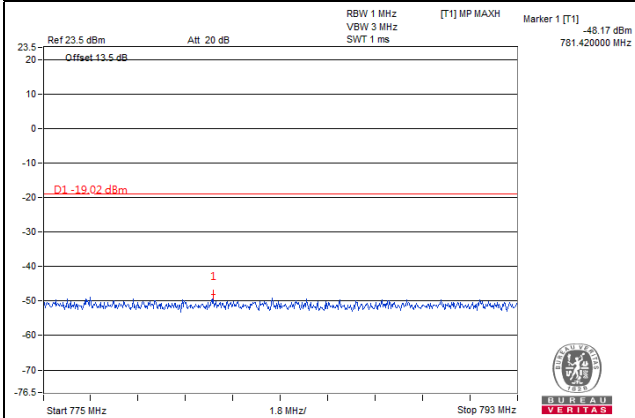

Frequency Range : 793MHz~805MHz

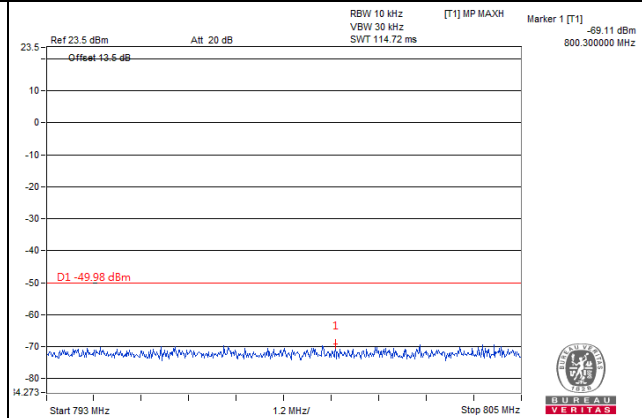

Frequency Range : 805MHz~1.559GHz

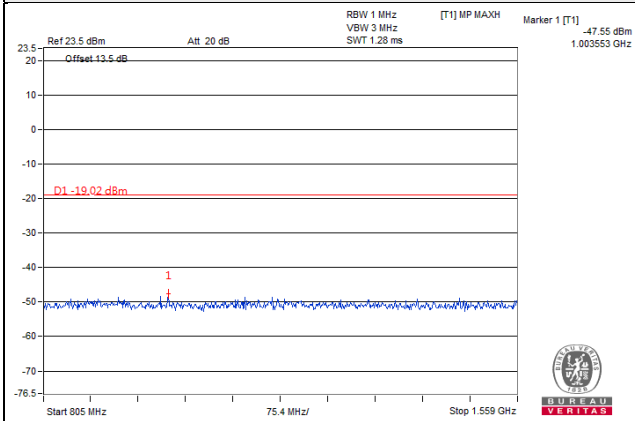

Frequency Range : 1.559GHz~1.610GHz

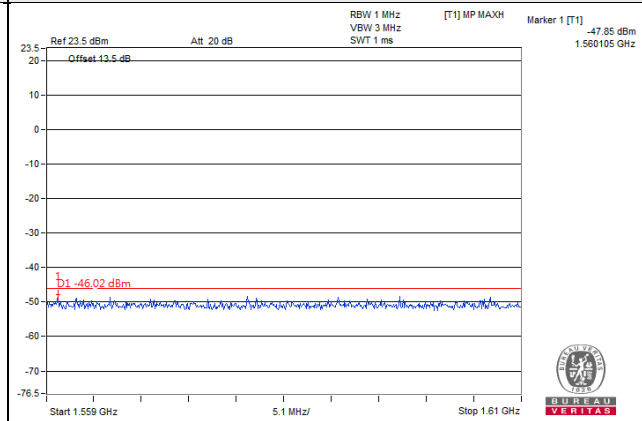

Frequency Range : 1.610GHz~9GHz

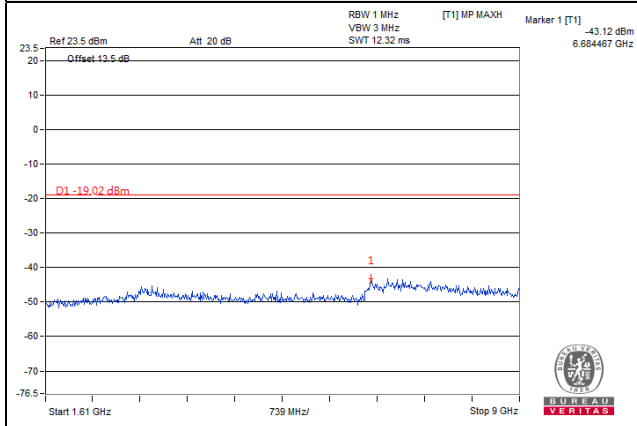

2-Carriers Mode (Chain 0)

Channel Band width: 5MHz + 5MHz

Channel 5230 (751.0MHz)

Frequency Range : 9kHz~763MHz

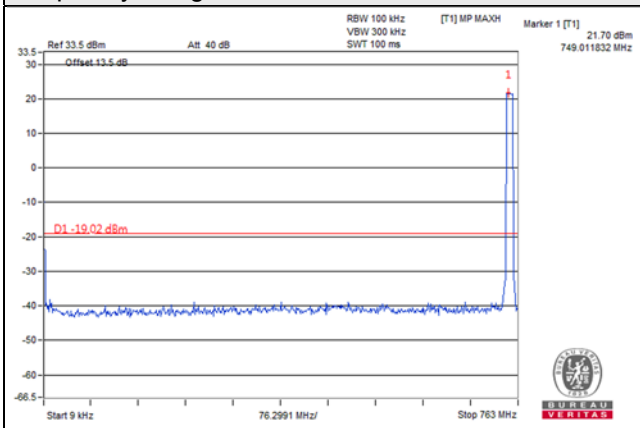

Frequency Range : 763MHz~775MHz

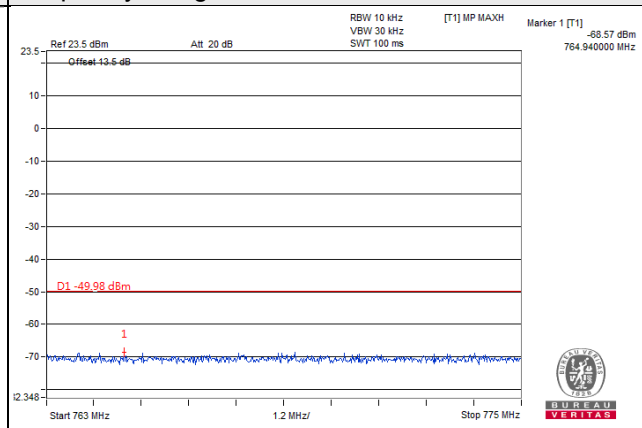

Frequency Range : 775MHz~793MHz

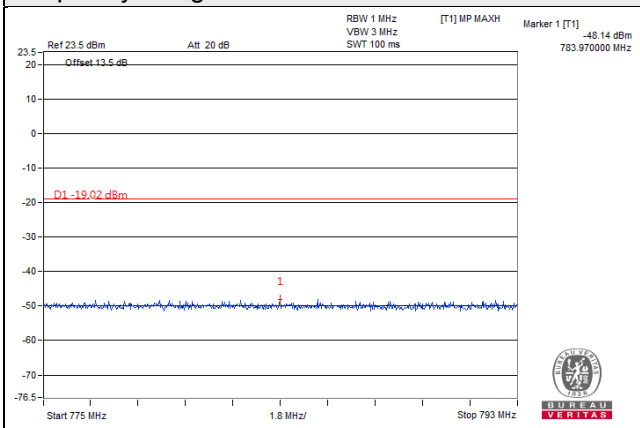

Frequency Range : 793MHz~805MHz

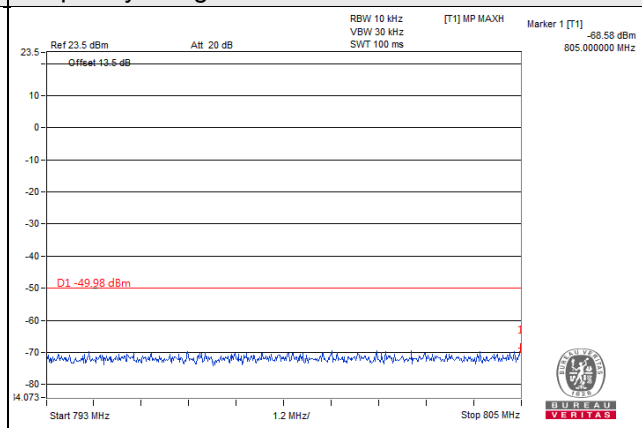

Frequency Range : 805MHz~1.559GHz

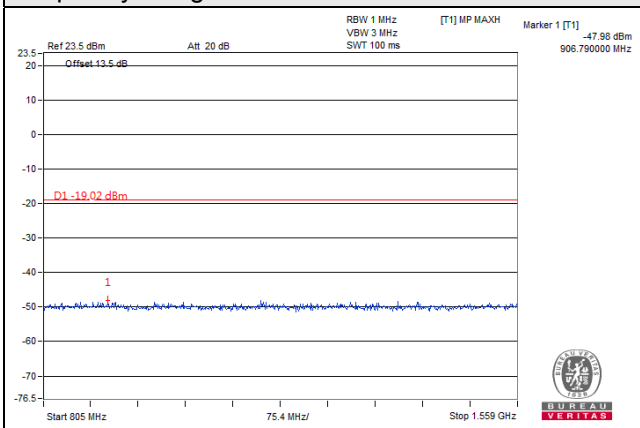

Frequency Range : 1.559GHz~1.610GHz

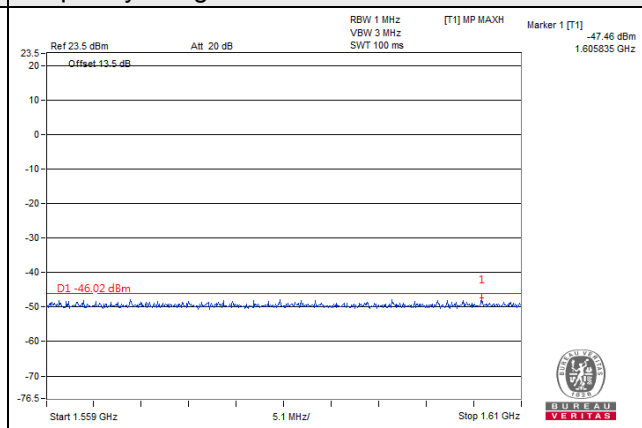

Frequency Range : 1.610GHz~9GHz

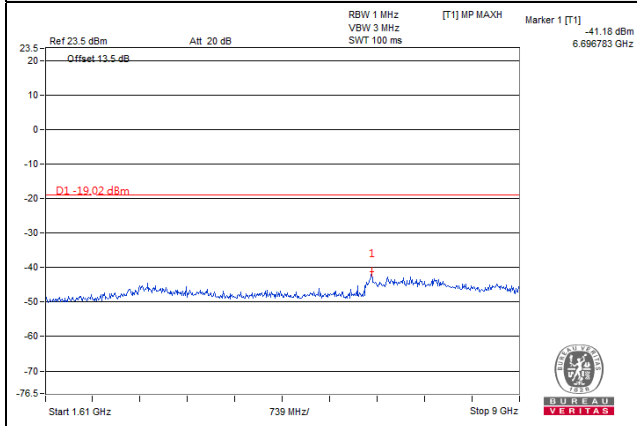

2-Carriers Mode (Chain 1)

Channel Band width: 5MHz + 5MHz

Channel 5230 (751.0MHz)

Frequency Range : 9kHz~763MHz

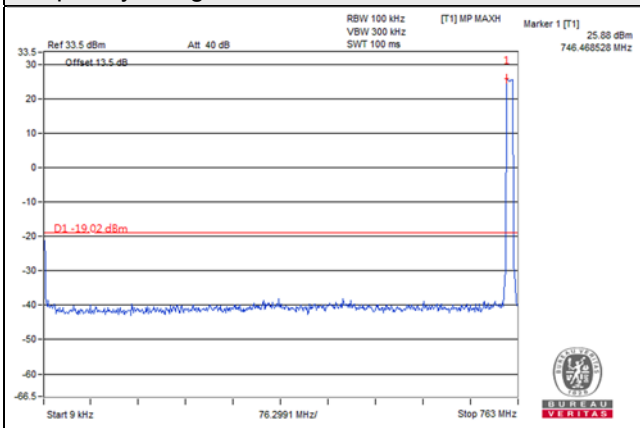

Frequency Range : 763MHz~775MHz

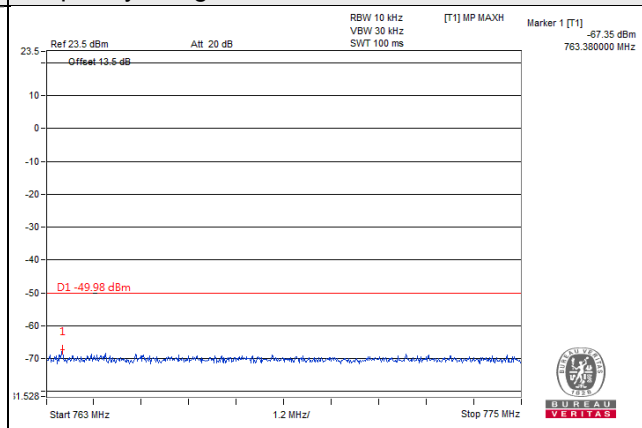

Frequency Range : 775MHz~793MHz

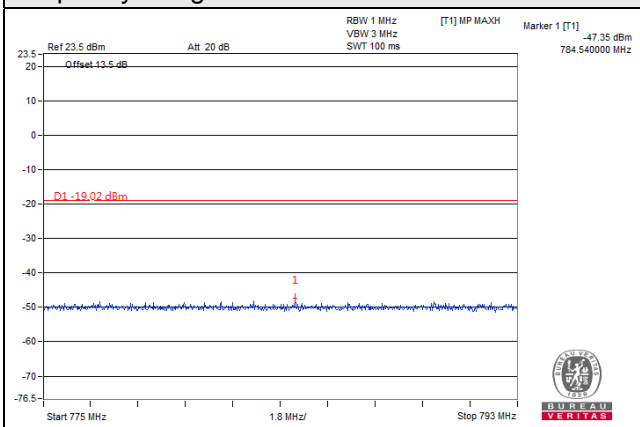

Frequency Range : 793MHz~805MHz

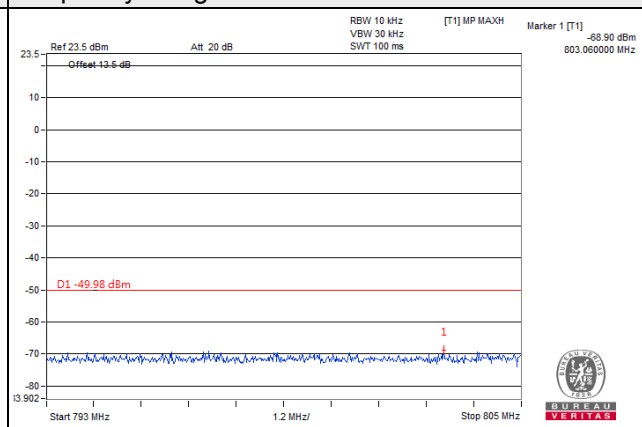

Frequency Range : 805MHz~1.559GHz

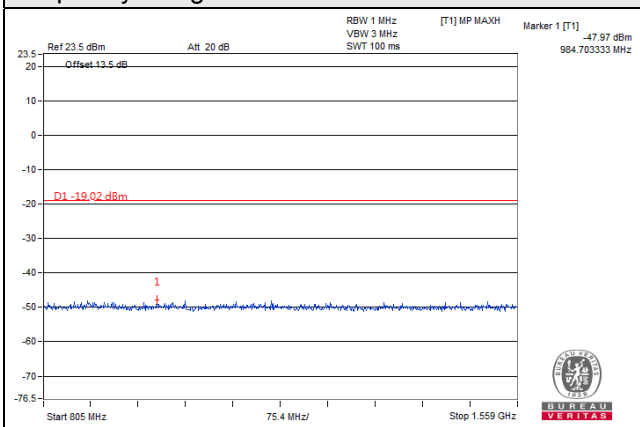

Frequency Range : 1.559GHz~1.610GHz

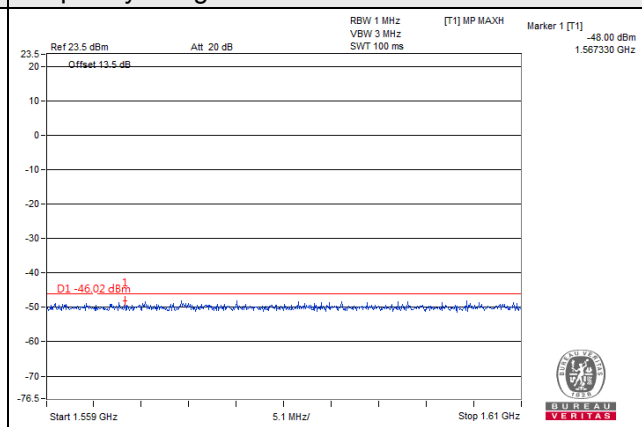

Frequency Range : 1.610GHz~9GHz

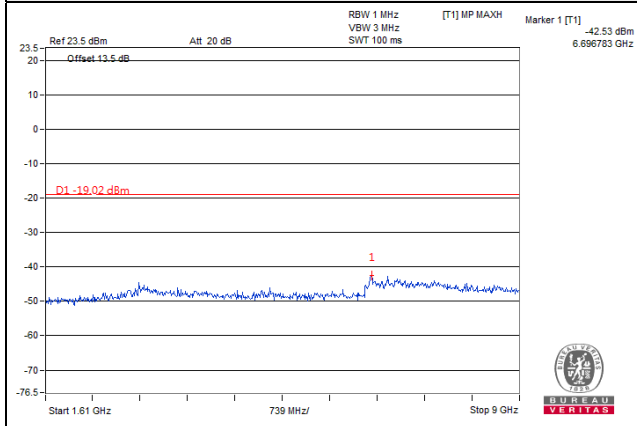

2-Carriers Mode (Chain 2)

Channel Band width: 5MHz + 5MHz

Channel 5230 (751.0MHz)

Frequency Range : 9kHz~763MHz

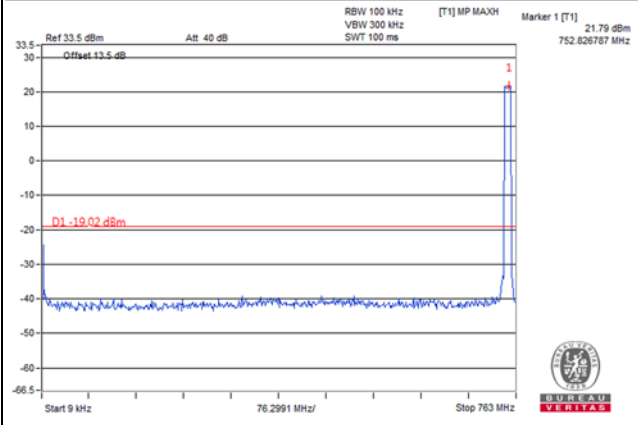

Frequency Range : 763MHz~775MHz

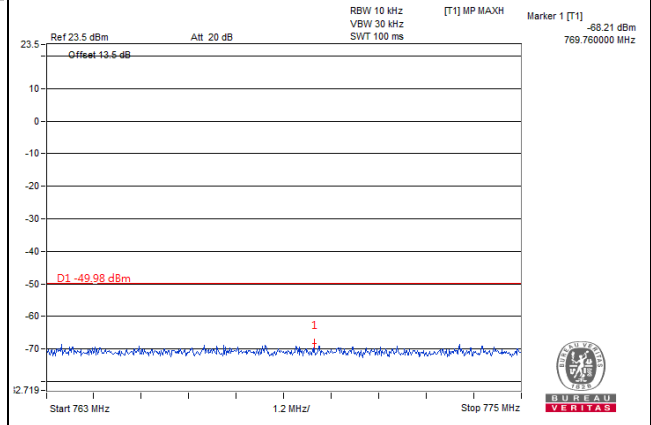

Frequency Range : 775MHz~793MHz

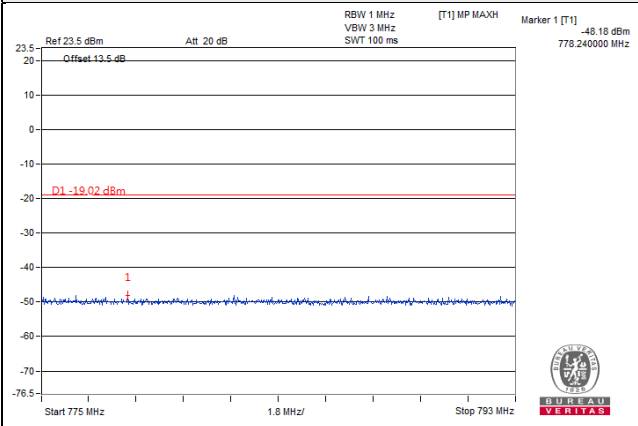

Frequency Range : 793MHz~805MHz

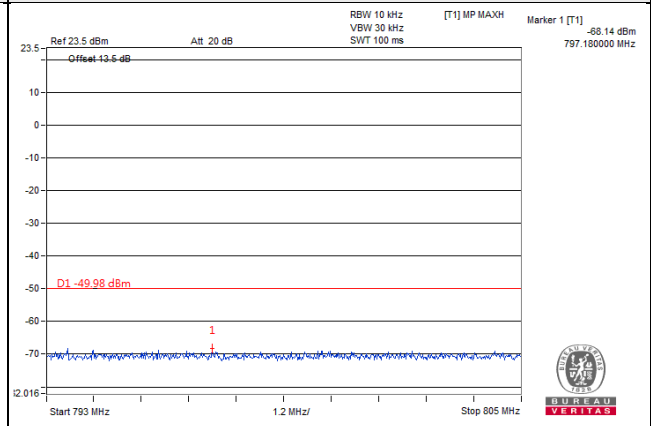

Frequency Range : 805MHz~1.559GHz

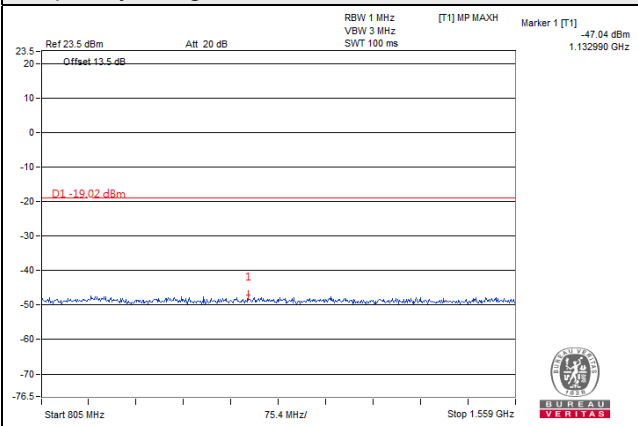

Frequency Range : 1.559GHz~1.610GHz

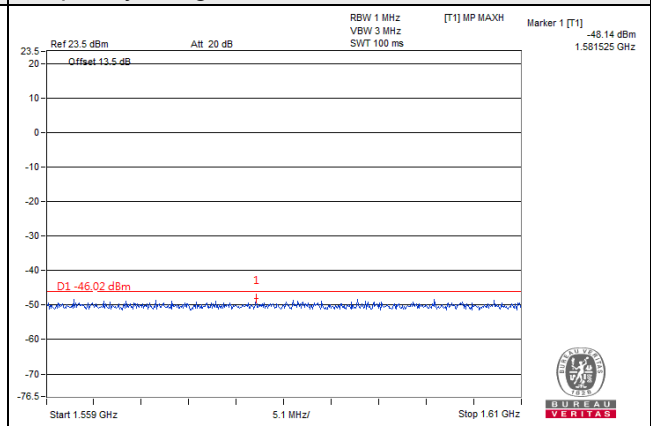

Frequency Range : 1.610GHz~9GHz

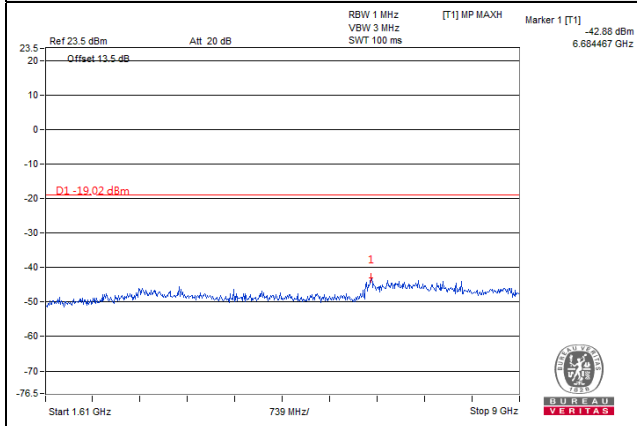

2-Carriers Mode (Chain 3)

Channel Band width: 5MHz + 5MHz

Channel 5230 (751.0MHz)

Frequency Range : 9kHz~763MHz

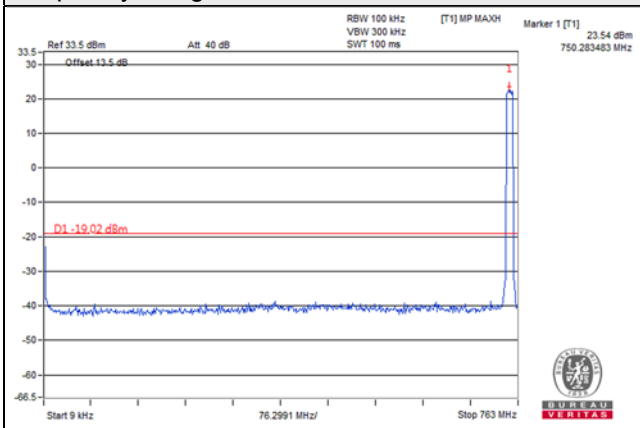

Frequency Range : 763MHz~775MHz

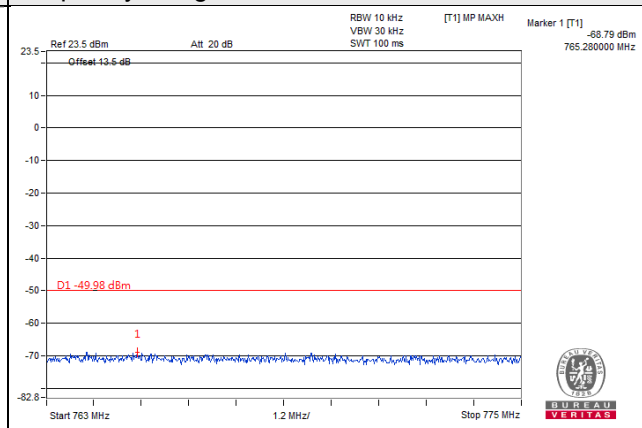

Frequency Range : 775MHz~793MHz

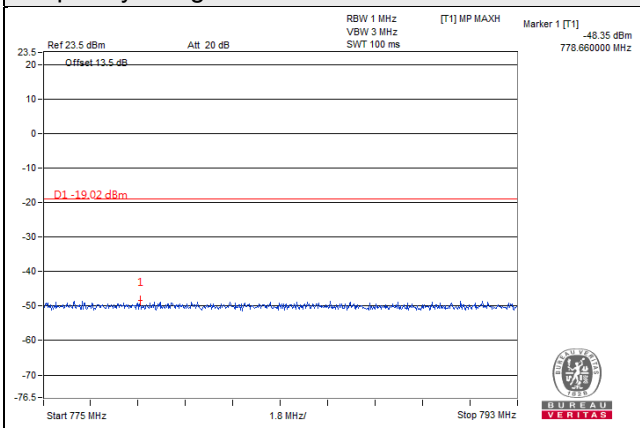

Frequency Range : 793MHz~805MHz

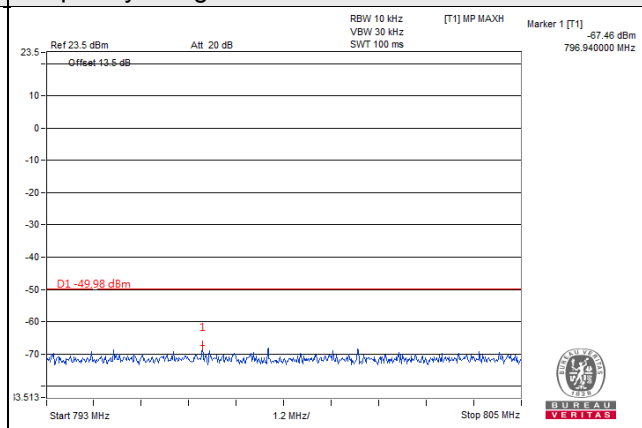

Frequency Range : 805MHz~1.559GHz

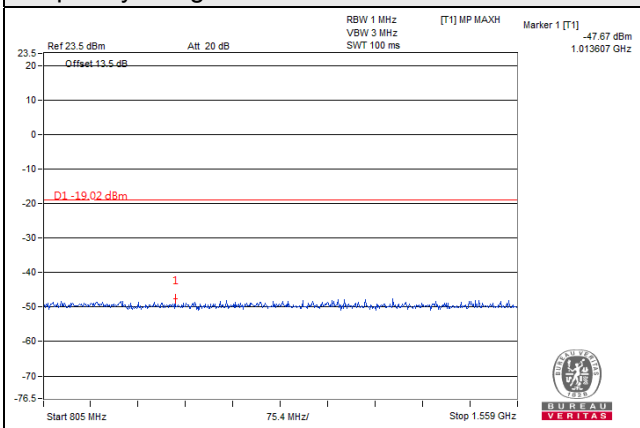

Frequency Range : 1.559GHz~1.610GHz

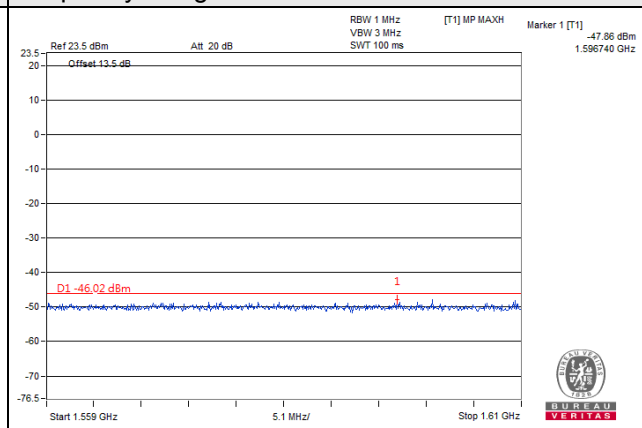

Frequency Range : 1.610GHz~9GHz

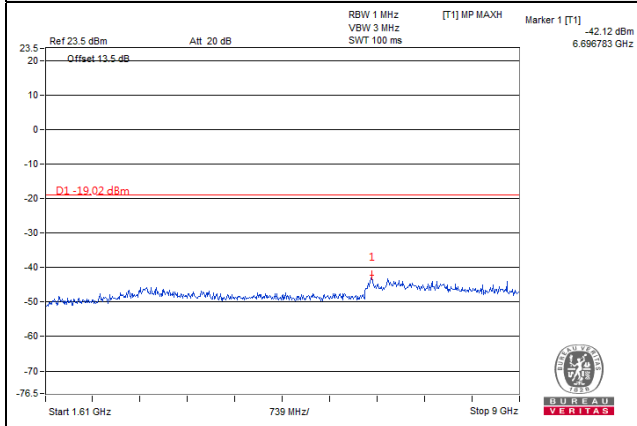

4.8 Radiated Emission Measurement

4.8.1 Limits of Radiated Emission Measurement

According to FCC 27.53(c), on any frequency outside a licensee's frequency block, the power of any emission shall be attenuated below the transmitter power (P) by at least $43 + 10 \log (P)$ dB, the emission limit equal to -13dBm.

4.8.2 Test Procedure

- a. The power was measured with R&S Spectrum Analyzer. All measurements were done at 3 channels (low, middle and high channel of operational frequency range.)
- b. Substitution method is used for E.I.R.P measurement. In the semi-anechoic chamber, EUT placed on the 0.8m height of Turn Table, rotated the table around 360 degrees to search the maximum radiation power and receiver antenna shall be rotated vertical and horizontal polarization and moved height from 1m to 4m to find the maximum polar radiated power. The "Read Value" is the spectrum reading the maximum power value.
- c. The substitution antenna is substituted for EUT at the same position and signals generator export the CW signal to the substitution antenna via a TX cable. Rotated the Turn Table and moved receiving antenna to find the maximum radiation power. Adjust output power level of S.G to get a Value of spectrum reading equal to "Read Value" of step b. Record the power level of S.G
- d. $EIRP = \text{Output power level of S.G} - \text{TX cable loss} + \text{Antenna gain of substitution antenna}$.

Note: The resolution bandwidth and video bandwidth of test receiver/spectrum analyzer is 1MHz/3MHz.

4.8.3 Deviation from Test Standard

No deviation.

4.8.4 Test Setup

For Radiated Emission below or equal 1GHz

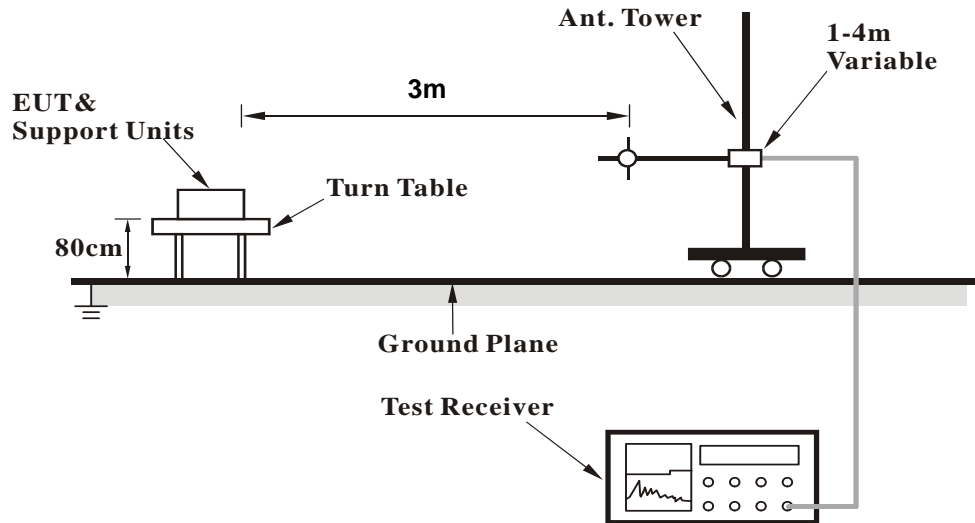

For Radiated Emission above 1GHz

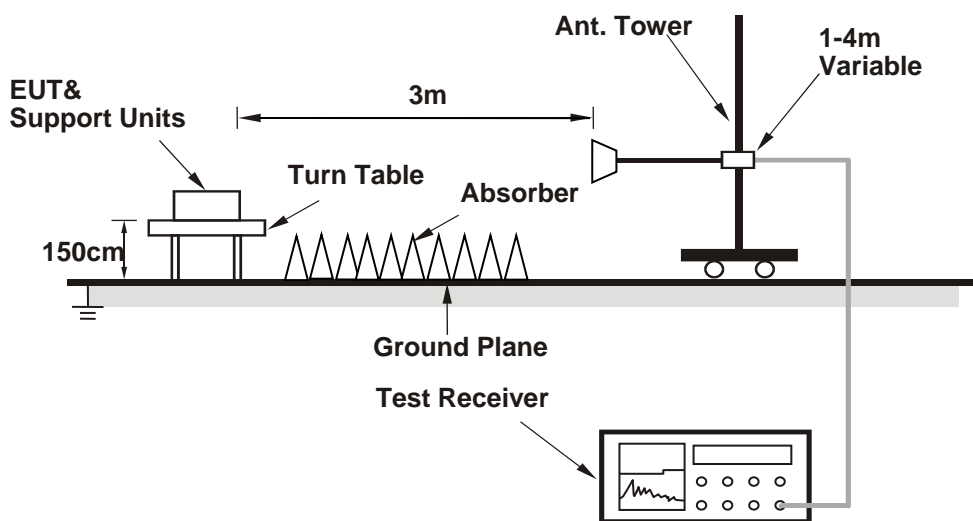

For the actual test configuration, please refer to the attached file (Test Setup Photo).

4.8.5 Test Results

Single Mode

Below 1GHz

Channel Bandwidth: 5MHz

| | | | |
|--------------------------|-------------------------------|-----------------|----------------|
| Mode | TX channel 5205 (748.5MHz) | Frequency Range | Below 1000 MHz |
| Environmental Conditions | 25deg. C, 65%RH | Input Power | 120Vac, 60Hz |
| Tested By | Han Wu | | |

| Antenna Polarity & Test Distance: Horizontal at 3 M | | | | | | | |
|---|-------------|---------------|-----------------------|------------------------|-----------|-------------|-------------|
| No. | Freq. (MHz) | Reading (dBm) | S.G Power Value (dBm) | Correction Factor (dB) | ERP (dBm) | Limit (dBm) | Margin (dB) |
| 1 | 47.46 | -54.60 | -47.40 | -9.20 | -56.60 | -13.00 | -43.60 |
| 2 | 153.19 | -57.50 | -61.00 | -2.90 | -63.90 | -13.00 | -50.90 |
| 3 | 223.03 | -57.00 | -65.30 | -2.00 | -67.30 | -13.00 | -54.30 |
| 4 | 286.08 | -52.00 | -56.30 | -1.70 | -58.00 | -13.00 | -45.00 |
| 5 | 374.35 | -55.20 | -63.00 | 3.70 | -59.30 | -13.00 | -46.30 |
| 6 | 482.99 | -54.90 | -60.90 | 3.60 | -57.30 | -13.00 | -44.30 |

Remarks:

- Output Power (dBm) = S.G Value (dBm) + Correction Factor (dB).
- Correction Factor (dB) = Substitution Antenna Gain (dB) + Cable Loss (dB).

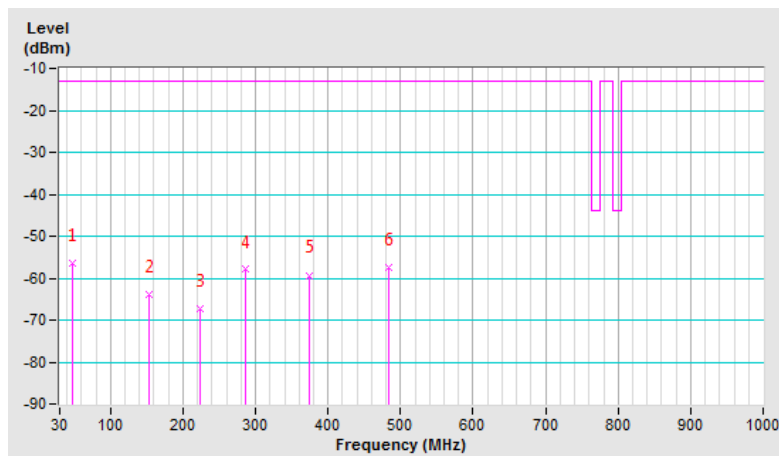

| | | | |
|--------------------------|-------------------------------|-----------------|----------------|
| Mode | TX channel 5205 (748.5MHz) | Frequency Range | Below 1000 MHz |
| Environmental Conditions | 25deg. C, 65%RH | Input Power | 120Vac, 60Hz |
| Tested By | Han Wu | | |

Antenna Polarity & Test Distance: Vertical at 3 M

| No. | Freq. (MHz) | Reading (dBm) | S.G Power Value (dBm) | Correction Factor (dB) | ERP (dBm) | Limit (dBm) | Margin (dB) |
|-----|-------------|---------------|-----------------------|------------------------|-----------|-------------|-------------|
| 1 | 109.54 | -57.20 | -65.10 | -2.50 | -67.60 | -13.00 | -54.60 |
| 2 | 176.47 | -58.00 | -61.00 | -2.90 | -63.90 | -13.00 | -50.90 |
| 3 | 269.59 | -56.80 | -55.70 | -1.40 | -57.10 | -13.00 | -44.10 |
| 4 | 434.49 | -55.60 | -61.50 | 3.60 | -57.90 | -13.00 | -44.90 |
| 5 | 542.16 | -55.80 | -60.40 | 3.90 | -56.50 | -13.00 | -43.50 |
| 6 | 691.54 | -58.80 | -58.70 | 3.50 | -55.20 | -13.00 | -42.20 |

Remarks:

- Output Power (dBm) = S.G Value (dBm) + Correction Factor (dB).
- Correction Factor (dB) = Substitution Antenna Gain (dB) + Cable Loss (dB).

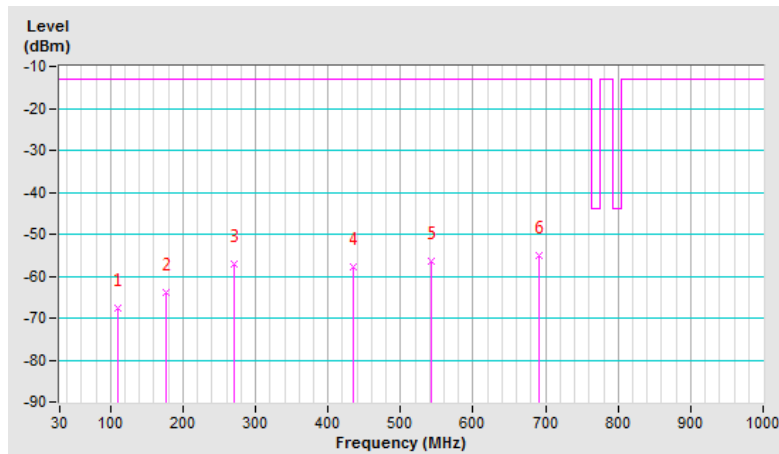

Channel Bandwidth: 10MHz

| | | | |
|--------------------------|-------------------------------|-----------------|----------------|
| Mode | TX channel 5230 (751.0MHz) | Frequency Range | Below 1000 MHz |
| Environmental Conditions | 25deg. C, 65%RH | Input Power | 120Vac, 60Hz |
| Tested By | Han Wu | | |

| Antenna Polarity & Test Distance: Horizontal at 3 M | | | | | | | |
|---|-------------|---------------|-----------------------|------------------------|-----------|-------------|-------------|
| No. | Freq. (MHz) | Reading (dBm) | S.G Power Value (dBm) | Correction Factor (dB) | ERP (dBm) | Limit (dBm) | Margin (dB) |
| 1 | 72.68 | -55.90 | -63.90 | -0.10 | -64.00 | -13.00 | -51.00 |
| 2 | 127.97 | -56.80 | -61.80 | -3.20 | -65.00 | -13.00 | -52.00 |
| 3 | 240.49 | -57.70 | -65.20 | -1.50 | -66.70 | -13.00 | -53.70 |
| 4 | 303.54 | -55.60 | -66.00 | 3.70 | -62.30 | -13.00 | -49.30 |
| 5 | 482.99 | -54.90 | -60.90 | 3.60 | -57.30 | -13.00 | -44.30 |
| 6 | 586.78 | -56.40 | -61.20 | 3.80 | -57.40 | -13.00 | -44.40 |

Remarks:

1. Output Power (dBm) = S.G Value (dBm) + Correction Factor (dB).
2. Correction Factor (dB) = Substitution Antenna Gain (dB) + Cable Loss (dB).

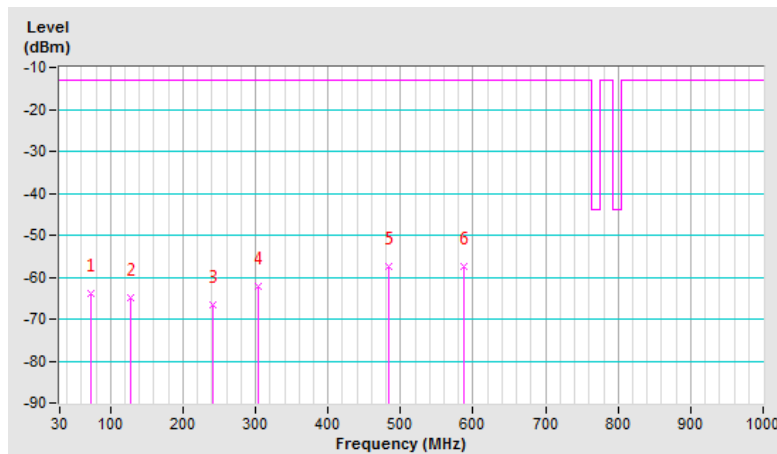

| | | | |
|--------------------------|-------------------------------|-----------------|----------------|
| Mode | TX channel 5230 (751.0MHz) | Frequency Range | Below 1000 MHz |
| Environmental Conditions | 25deg. C, 65%RH | Input Power | 120Vac, 60Hz |
| Tested By | Han Wu | | |

Antenna Polarity & Test Distance: Vertical at 3 M

| No. | Freq. (MHz) | Reading (dBm) | S.G Power Value (dBm) | Correction Factor (dB) | ERP (dBm) | Limit (dBm) | Margin (dB) |
|-----|-------------|---------------|-----------------------|------------------------|-----------|-------------|-------------|
| 1 | 62.98 | -54.90 | -61.40 | -2.40 | -63.80 | -13.00 | -50.80 |
| 2 | 127.97 | -56.60 | -61.10 | -3.20 | -64.30 | -13.00 | -51.30 |
| 3 | 245.34 | -57.10 | -58.90 | -1.60 | -60.50 | -13.00 | -47.50 |
| 4 | 346.22 | -57.50 | -64.20 | 3.90 | -60.30 | -13.00 | -47.30 |
| 5 | 474.26 | -55.00 | -60.90 | 3.50 | -57.40 | -13.00 | -44.40 |
| 6 | 610.06 | -58.20 | -59.40 | 3.70 | -55.70 | -13.00 | -42.70 |

Remarks:

- Output Power (dBm) = S.G Value (dBm) + Correction Factor (dB).
- Correction Factor (dB) = Substitution Antenna Gain (dB) + Cable Loss (dB).

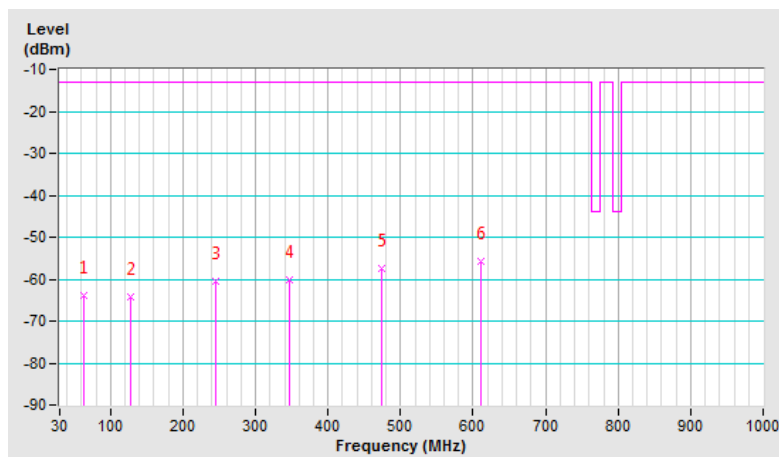

Above 1GHz

Channel Bandwidth: 5MHz

| | | | |
|--------------------------|-------------------------------|-----------------|---------------|
| Mode | TX channel 5205 (748.5MHz) | Frequency Range | Above 1000MHz |
| Environmental Conditions | 25deg. C, 65%RH | Input Power | 120Vac, 60Hz |
| Tested By | Han Wu | | |

| Antenna Polarity & Test Distance: Horizontal at 3 M | | | | | | | |
|---|-------------|---------------|-----------------------|------------------------|-----------|-------------|-------------|
| No. | Freq. (MHz) | Reading (dBm) | S.G Power Value (dBm) | Correction Factor (dB) | ERP (dBm) | Limit (dBm) | Margin (dB) |
| 1 | 1497.00 | -59.40 | -52.00 | 1.50 | -50.50 | -13.00 | -37.50 |
| Antenna Polarity & Test Distance: Vertical at 3 M | | | | | | | |
| No. | Freq. (MHz) | Reading (dBm) | S.G Power Value (dBm) | Correction Factor (dB) | ERP (dBm) | Limit (dBm) | Margin (dB) |
| 1 | 1497.00 | -60.50 | -54.30 | 1.50 | -52.80 | -13.00 | -39.80 |

Remarks:

1. Output Power (dBm) = S.G Value (dBm) + Correction Factor (dB).
2. Correction Factor (dB) = Substitution Antenna Gain (dB) + Cable Loss (dB).

| | | | |
|--------------------------|-------------------------------|-----------------|---------------|
| Mode | TX channel 5230 (751.0MHz) | Frequency Range | Above 1000MHz |
| Environmental Conditions | 25deg. C, 65%RH | Input Power | 120Vac, 60Hz |
| Tested By | Han Wu | | |

| Antenna Polarity & Test Distance: Horizontal at 3 M | | | | | | | |
|---|-------------|---------------|-----------------------|------------------------|-----------|-------------|-------------|
| No. | Freq. (MHz) | Reading (dBm) | S.G Power Value (dBm) | Correction Factor (dB) | ERP (dBm) | Limit (dBm) | Margin (dB) |
| 1 | 1502.00 | -60.50 | -53.10 | 1.50 | -51.60 | -13.00 | -38.60 |
| Antenna Polarity & Test Distance: Vertical at 3 M | | | | | | | |
| No. | Freq. (MHz) | Reading (dBm) | S.G Power Value (dBm) | Correction Factor (dB) | ERP (dBm) | Limit (dBm) | Margin (dB) |
| 1 | 1502.00 | -62.40 | -56.00 | 1.50 | -54.50 | -13.00 | -41.50 |

Remarks:

1. Output Power (dBm) = S.G Value (dBm) + Correction Factor (dB).
2. Correction Factor (dB) = Substitution Antenna Gain (dB) + Cable Loss (dB).

| | | | |
|--------------------------|-------------------------------|-----------------|---------------|
| Mode | TX channel 5255 (753.5MHz) | Frequency Range | Above 1000MHz |
| Environmental Conditions | 25deg. C, 65%RH | Input Power | 120Vac, 60Hz |
| Tested By | Han Wu | | |

| Antenna Polarity & Test Distance: Horizontal at 3 M | | | | | | | |
|---|-------------|---------------|-----------------------|------------------------|-----------|-------------|-------------|
| No. | Freq. (MHz) | Reading (dBm) | S.G Power Value (dBm) | Correction Factor (dB) | ERP (dBm) | Limit (dBm) | Margin (dB) |
| 1 | 1507.00 | -62.00 | -54.60 | 1.50 | -53.10 | -13.00 | -40.10 |
| Antenna Polarity & Test Distance: Vertical at 3 M | | | | | | | |
| No. | Freq. (MHz) | Reading (dBm) | S.G Power Value (dBm) | Correction Factor (dB) | ERP (dBm) | Limit (dBm) | Margin (dB) |
| 1 | 1507.00 | -61.90 | -55.50 | 1.50 | -54.00 | -13.00 | -41.00 |

Remarks:

1. Output Power (dBm) = S.G Value (dBm) + Correction Factor (dB).
2. Correction Factor (dB) = Substitution Antenna Gain (dB) + Cable Loss (dB).

Channel Bandwidth: 10MHz

| | | | |
|--------------------------|-------------------------------|-----------------|---------------|
| Mode | TX channel 5230 (751.0MHz) | Frequency Range | Above 1000MHz |
| Environmental Conditions | 25deg. C, 65%RH | Input Power | 120Vac, 60Hz |
| Tested By | Han Wu | | |

| Antenna Polarity & Test Distance: Horizontal at 3 M | | | | | | | |
|---|-------------|---------------|-----------------------|------------------------|-----------|-------------|-------------|
| No. | Freq. (MHz) | Reading (dBm) | S.G Power Value (dBm) | Correction Factor (dB) | ERP (dBm) | Limit (dBm) | Margin (dB) |
| 1 | 1502.00 | -62.50 | -55.00 | 1.50 | -53.50 | -13.00 | -40.50 |
| Antenna Polarity & Test Distance: Vertical at 3 M | | | | | | | |
| No. | Freq. (MHz) | Reading (dBm) | S.G Power Value (dBm) | Correction Factor (dB) | ERP (dBm) | Limit (dBm) | Margin (dB) |
| 1 | 1502.00 | -62.40 | -56.00 | 1.50 | -54.50 | -13.00 | -41.50 |

Remarks:

1. Output Power (dBm) = S.G Value (dBm) + Correction Factor (dB).
2. Correction Factor (dB) = Substitution Antenna Gain (dB) + Cable Loss (dB).

2-Carriers Mode

Below 1GHz

Channel Bandwidth: 5MHz + 5MHz

| | | | |
|--------------------------|-------------------------------|-----------------|----------------|
| Mode | TX channel 5230 (751.0MHz) | Frequency Range | Below 1000 MHz |
| Environmental Conditions | 25deg. C, 65%RH | Input Power | 120Vac, 60Hz |
| Tested By | Han Wu | | |

| Antenna Polarity & Test Distance: Horizontal at 3 M | | | | | | | |
|---|-------------|---------------|-----------------------|------------------------|-----------|-------------|-------------|
| No. | Freq. (MHz) | Reading (dBm) | S.G Power Value (dBm) | Correction Factor (dB) | ERP (dBm) | Limit (dBm) | Margin (dB) |
| 1 | 59.10 | -53.40 | -56.20 | -3.80 | -60.00 | -13.00 | -47.00 |
| 2 | 153.19 | -57.50 | -61.00 | -2.90 | -63.90 | -13.00 | -50.90 |
| 3 | 286.08 | -52.00 | -56.30 | -1.70 | -58.00 | -13.00 | -45.00 |
| 4 | 340.40 | -55.90 | -65.50 | 4.00 | -61.50 | -13.00 | -48.50 |
| 5 | 512.09 | -56.20 | -62.10 | 3.90 | -58.20 | -13.00 | -45.20 |
| 6 | 577.08 | -56.50 | -61.30 | 3.70 | -57.60 | -13.00 | -44.60 |

Remarks:

- Output Power (dBm) = S.G Value (dBm) + Correction Factor (dB).
- Correction Factor (dB) = Substitution Antenna Gain (dB) + Cable Loss (dB).

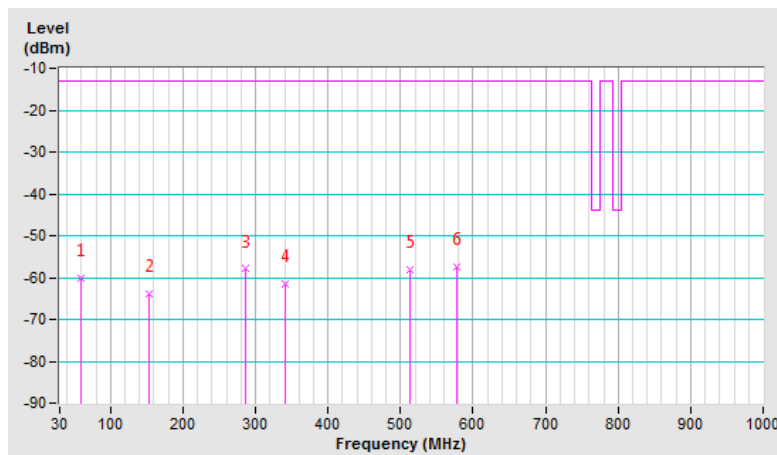

| | | | |
|--------------------------|-------------------------------|-----------------|----------------|
| Mode | TX channel 5230 (751.0MHz) | Frequency Range | Below 1000 MHz |
| Environmental Conditions | 25deg. C, 65%RH | Input Power | 120Vac, 60Hz |
| Tested By | Han Wu | | |

Antenna Polarity & Test Distance: Vertical at 3 M

| No. | Freq. (MHz) | Reading (dBm) | S.G Power Value (dBm) | Correction Factor (dB) | ERP (dBm) | Limit (dBm) | Margin (dB) |
|-----|-------------|---------------|-----------------------|------------------------|-----------|-------------|-------------|
| 1 | 142.52 | -57.40 | -58.60 | -3.10 | -61.70 | -13.00 | -48.70 |
| 2 | 286.08 | -51.60 | -50.00 | -1.70 | -51.70 | -13.00 | -38.70 |
| 3 | 330.70 | -53.40 | -60.00 | 4.00 | -56.00 | -13.00 | -43.00 |
| 4 | 418.00 | -53.60 | -59.50 | 3.40 | -56.10 | -13.00 | -43.10 |
| 5 | 590.66 | -57.00 | -60.20 | 3.80 | -56.40 | -13.00 | -43.40 |
| 6 | 729.37 | -55.40 | -54.70 | 3.60 | -51.10 | -13.00 | -38.10 |

Remarks:

1. Output Power (dBm) = S.G Value (dBm) + Correction Factor (dB).
2. Correction Factor (dB) = Substitution Antenna Gain (dB) + Cable Loss (dB).

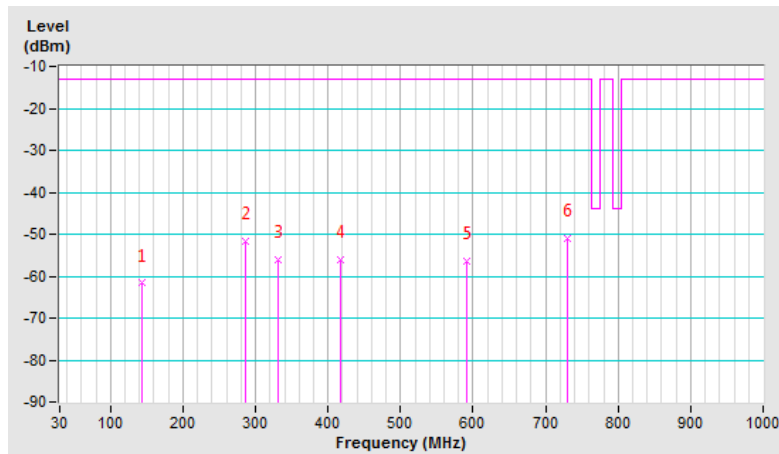

Above 1GHz

Channel Bandwidth: 5MHz + 5MHz

| | | | |
|--------------------------|-------------------------------|-----------------|---------------|
| Mode | TX channel 5230 (751.0MHz) | Frequency Range | Above 1000MHz |
| Environmental Conditions | 25deg. C, 65%RH | Input Power | 120Vac, 60Hz |
| Tested By | Han Wu | | |

| Antenna Polarity & Test Distance: Horizontal at 3 M | | | | | | | |
|---|-------------|---------------|-----------------------|------------------------|-----------|-------------|-------------|
| No. | Freq. (MHz) | Reading (dBm) | S.G Power Value (dBm) | Correction Factor (dB) | ERP (dBm) | Limit (dBm) | Margin (dB) |
| 1 | 1502.00 | -60.70 | -53.20 | 1.50 | -51.70 | -13.00 | -38.70 |
| Antenna Polarity & Test Distance: Vertical at 3 M | | | | | | | |
| No. | Freq. (MHz) | Reading (dBm) | S.G Power Value (dBm) | Correction Factor (dB) | ERP (dBm) | Limit (dBm) | Margin (dB) |
| 1 | 1502.00 | -62.00 | -55.60 | 1.50 | -54.10 | -13.00 | -41.10 |

Remarks:

1. Output Power (dBm) = S.G Value (dBm) + Correction Factor (dB).
2. Correction Factor (dB) = Substitution Antenna Gain (dB) + Cable Loss (dB).

5 Pictures of Test Arrangements

Please refer to the attached file (Test Setup Photo).

Appendix – Information on the Testing Laboratories

We, Bureau Veritas Consumer Products Services (H.K.) Ltd., Taoyuan Branch, were founded in 1988 to provide our best service in EMC, Radio, Telecom and Safety consultation. Our laboratories are FCC recognized accredited test firms and accredited and approved according to ISO/IEC 17025.

If you have any comments, please feel free to contact us at the following:

Linko EMC/RF Lab

Tel: 886-2-26052180

Fax: 886-2-26051924

Hsin Chu EMC/RF/Telecom Lab

Tel: 886-3-6668565

Fax: 886-3-6668323

Hwa Ya EMC/RF/Safety Lab

Tel: 886-3-3183232

Fax: 886-3-3270892

Email: service.adt@tw.bureauveritas.com

Web Site: www.bureauveritas-adt.com

The address and road map of all our labs can be found in our web site also.

--- END ---