

S

T

S

L

A

B



FCC TEST REPORT

Report No: STS1412068F01

Issued for

shenzhen waveguider optical telecom technology inc.

Room 1207-1211,Bldg,Zhantao Technology
Building,Minzhi Road,Longhua New District,Shenzhen

| | |
|----------------|-----------------|
| Product Name: | T Touch |
| Brand Name: | N/A |
| Model No.: | HB-04 |
| Series Model: | N/A |
| FCC ID: | 2AD7CHB-04 |
| Test Standard: | FCC Part 15.247 |

Any reproduction of this document must be done in full. No single part of this document may be reproduced without permission from STS, All Test Data Presented in this report is only applicable to presented Test sample.

Shenzhen STS Test Services Co., Ltd.

1/F A, Building 2, Zhuoke Science Park, Chongqing Road, Fuyong, Baoan District, Shenzhen, China

TEL: +86-755 3688 6288 FAX: +86-755 3688 6277 E-mail: sts@stsapp.com





TEST RESULT CERTIFICATION

Applicant's name: shenzhen waveguider optical telecom technology inc.
Address.....: Room 1207-1211,Bldg,Zhantao Technology Building,Minzhi Road,Longhua New District,Shenzhen
Manufacture's Name: shenzhen waveguider optical telecom technology inc.
Address.....: Room 1207-1211,Bldg,Zhantao Technology Building,Minzhi Road,Longhua New District,Shenzhen

Product description

Product name.....: T Touch
Model and/or type reference ..: HB-04
Serial Model: N/A

Standards.....: FCC Part15.247

Test procedure ANSI C63.10: 2009

This device described above has been tested by STS, and the test results show that the equipment under test (EUT) is in compliance with the FCC requirements. And it is applicable only to the tested sample identified in the report.

This report shall not be reproduced except in full, without the written approval of STS, this document may be altered or revised by STS, personal only, and shall be noted in the revision of the document.

Date of Test:
Date (s) of performance of tests: 25 Dec. 2014 ~31 Dec. 2014
Date of Issue: 04 Jan. 2015
Test Result.....: **Pass**

Testing Engineer : 

 (Tony Liu)

Technical Manager : 

 (Vita Li)

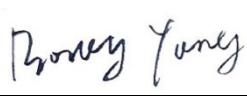
Authorized Signatory : 

 (Bovey Yang)





| Table of Contents | Page |
|---|-------------|
| 1. SUMMARY OF TEST RESULTS | 5 |
| 1.1 TEST FACILITY | 5 |
| 1.2 MEASUREMENT UNCERTAINTY | 5 |
| 2. GENERAL INFORMATION | 6 |
| 2.1 GENERAL DESCRIPTION OF EUT | 6 |
| 2.2 DESCRIPTION OF TEST MODES | 8 |
| 2.3 BLOCK DIGRAM SHOWING THE CONFIGURATION OF SYSTEM TESTED | 9 |
| 2.4 DESCRIPTION OF SUPPORT UNITS(CONDUCTED MODE) | 10 |
| 2.5 EQUIPMENTS LIST FOR ALL TEST ITEMS | 11 |
| 3. EMC EMISSION TEST | 12 |
| 3.1 CONDUCTED EMISSION MEASUREMENT | 12 |
| 3.2 TEST PROCEDURE | 13 |
| 3.3 TEST SETUP | 13 |
| 3.4 EUT OPERATING CONDITIONS | 13 |
| 3.5 TEST RESULTS | 14 |
| 4. RADIATED EMISSION MEASUREMENT | 16 |
| 4.1 RADIATED EMISSION LIMITS | 16 |
| 4.2 TEST PROCEDURE | 17 |
| 4.3 TEST SETUP | 18 |
| 4.4 EUT OPERATING CONDITIONS | 19 |
| 4.5 TEST RESULTS | 20 |
| 4.6 TEST RESULTS (RESTRICTED BANDS REQUIREMENTS) | 26 |
| 5. CONDUCTED SPURIOUS EMISSIONS | 27 |
| 5.1 REQUIREMENT | 27 |
| 5.2 TEST PROCEDURE | 27 |
| 5.3 TEST SETUP | 27 |
| 5.4 EUT OPERATION CONDITIONS | 27 |
| 5.5 TEST RESULTS | 28 |
| 6. POWER SPECTRAL DENSITY TEST | 31 |
| 6.1 APPLIED PROCEDURES / LIMIT | 31 |
| 6.2 TEST PROCEDURE | 31 |
| 6.3 TEST SETUP | 31 |



| Table of Contents | Page |
|---------------------------------------|-------------|
| 6.4 EUT OPERATION CONDITIONS | 31 |
| 6.5 TEST RESULTS | 32 |
| 7. BANDWIDTH TEST | 34 |
| 7.1 APPLIED PROCEDURES / LIMIT | 34 |
| 7.2 TEST PROCEDURE | 34 |
| 7.3 TEST SETUP | 34 |
| 7.4 EUT OPERATION CONDITIONS | 34 |
| 7.5 TEST RESULTS | 35 |
| 8. PEAK OUTPUT POWER TEST | 37 |
| 8.1 APPLIED PROCEDURES / LIMIT | 37 |
| 8.2 TEST PROCEDURE | 37 |
| 8.3 TEST SETUP | 37 |
| 8.4 EUT OPERATION CONDITIONS | 37 |
| 8.5 TEST RESULTS | 38 |
| 9. ANTENNA REQUIREMENT | 40 |
| 9.1 STANDARD REQUIREMENT | 40 |
| 9.2 EUT ANTENNA | 40 |
| 10. EUT TEST PHOTO | 41 |

1. SUMMARY OF TEST RESULTS

Test procedures according to the technical standards:

| FCC Part15 (15.247) , Subpart C | | | |
|---------------------------------|----------------------------|----------|--------|
| Standard Section | Test Item | Judgment | Remark |
| 15.207 | Conducted Emission | PASS | |
| 15.247 (a)(2) | 6dB Bandwidth | PASS | |
| 15.247 (b) | Peak Output Power | PASS | |
| 15.247 (c) | Radiated Spurious Emission | PASS | |
| 15.247 (d) | Power Spectral Density | PASS | |
| 15.205 | Band Edge Emission | PASS | |
| 15.203 | Antenna Requirement | PASS | |

NOTE:

(1) "N/A" denotes test is not applicable in this Test Report

1.1 TEST FACILITY

Shenzhen STS Test Services Co., Ltd.

Add. : 1/F, Building 2, Zhuoke Science Park, Chongqing Road, Fuyong, Baoan District, Shenzhen, China.

FCC Registration No.: 842334; IC Registration No.: 12108A-1

1.2 MEASUREMENT UNCERTAINTY

The reported uncertainty of measurement $y \pm U$, where expanded uncertainty U is based on a standard uncertainty multiplied by a coverage factor of $k=2$, providing a level of confidence of approximately **95** %.

| No. | Item | Uncertainty |
|-----|------------------------------|-------------------------|
| 1 | Conducted Emission Test | $\pm 1.38\text{dB}$ |
| 2 | RF power,conducted | $\pm 0.16\text{dB}$ |
| 3 | Spurious emissions,conducted | $\pm 0.21\text{dB}$ |
| 4 | All emissions,radiated(<1G) | $\pm 4.68\text{dB}$ |
| 5 | All emissions,radiated(>1G) | $\pm 4.89\text{dB}$ |
| 6 | Temperature | $\pm 0.5^\circ\text{C}$ |
| 7 | Humidity | $\pm 2\%$ |



2. GENERAL INFORMATION

2.1 GENERAL DESCRIPTION OF EUT

| | | |
|----------------------------|-----------------------------------|--------------------|
| Equipment | T Touch | |
| Trade Name | N/A | |
| Model Name | HB-04 | |
| Serial Model | N/A | |
| Model Difference | N/A | |
| Product Description | The EUT is a T Touch | |
| | Operation Frequency: | 2402~2480 MHz |
| | Modulation Type: | GFSK |
| | Radio Technology | Bluetooth 4.0 |
| | Number Of Channel | 40 |
| | Antenna Designation: | Please see Note 3. |
| | Antenna Gain (dBi) | 0 dBi |
| Channel List | Please refer to the Note 2. | |
| Battery | Rated Voltage: 3.7V | |
| | Charge Limit: 3.0~4.2V | |
| | capacity :260mAh | |
| Hardware version number | WG-DS-04_V2.1 | |
| Software versioning number | -- | |
| Connecting I/O Port(s) | Please refer to the User's Manual | |

Note:

1. For a more detailed features description, please refer to the manufacturer's specifications or the User's Manual.



2.

| Channel List | | | | | | | |
|--------------|-----------------|---------|-----------------|---------|-----------------|---------|-----------------|
| Channel | Frequency (MHz) | Channel | Frequency (MHz) | Channel | Frequency (MHz) | Channel | Frequency (MHz) |
| 00 | 2402 | 11 | 2422 | 21 | 2442 | 31 | 2462 |
| 01 | 2404 | 12 | 2424 | 22 | 2444 | 32 | 2464 |
| 02 | 2406 | 13 | 2426 | 23 | 2446 | 33 | 2466 |
| 03 | 2408 | 14 | 2428 | 24 | 2448 | 34 | 2468 |
| 05 | 2410 | 15 | 2430 | 25 | 2450 | 35 | 2470 |
| 06 | 2412 | 16 | 2432 | 26 | 2452 | 36 | 2472 |
| 07 | 2414 | 17 | 2434 | 27 | 2454 | 37 | 2474 |
| 08 | 2416 | 18 | 2436 | 28 | 2456 | 38 | 2476 |
| 09 | 2418 | 19 | 2438 | 29 | 2458 | 39 | 2478 |
| 10 | 2420 | 20 | 2440 | 30 | 2460 | 40 | 2480 |

3.

Table for Filed Antenna

| Ant | Brand | Model Name | Antenna Type | Connector | Gain (dBi) | NOTE |
|-----|-------|------------|-----------------|-----------|------------|------------|
| A | N/A | N/A | ceramic Antenna | N/A | 0 | BT 4.0 ANT |





2.2 DESCRIPTION OF TEST MODES

To investigate the maximum EMI emission characteristics generates from EUT, the test system was pre-scanning tested base on the consideration of following EUT operation mode or test configuration mode which possible have effect on EMI emission level. Each of these EUT operation mode(s) or test configuration mode(s) mentioned above was evaluated respectively.

| Pretest Mode | Description |
|--------------|------------------|
| Mode 1 | TX CH1/CH20/CH40 |
| Mode 2 | Link Mode |

| For Conducted Emission | |
|------------------------|-------------|
| Final Test Mode | Description |
| Mode 2 | Link Mode |

| For Radiated Emission | |
|-----------------------|------------------|
| Final Test Mode | Description |
| Mode 1 | TX CH1/CH20/CH40 |
| Mode 2 | Link Mode |

Note:

- (1) The measurements are performed at the highest, middle, lowest available channels.
- (2) The measurements are performed at all Bit Rate of Transmitter, the worst data was reported



2.3 BLOCK DIGRAM SHOWING THE CONFIGURATION OF SYSTEM TESTED

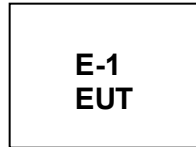



2.4 DESCRIPTION OF SUPPORT UNITS(CONDUCTED MODE)

The EUT has been tested as an independent unit together with other necessary accessories or support units. The following support units or accessories were used to form a representative test configuration during the tests.

| Item | Equipment | Mfr/Brand | Model/Type No. | Series No. | Note |
|------|-----------|-----------|----------------|------------|------|
| E-1 | T Touch | N/A | HB-04 | N/A | EUT |
| | | | | | |
| | | | | | |
| | | | | | |
| | | | | | |

| Item | Shielded Type | Ferrite Core | Length | Note |
|------|---------------|--------------|--------|------|
| C-1 | NO | YES | 1.5m | |
| C-2 | NO | NO | 1.2m | |
| | | | | |
| | | | | |
| | | | | |

Note:

- (1) The support equipment was authorized by Declaration of Confirmation.
- (2) For detachable type I/O cable should be specified the length in cm in 『Length』 column.



2.5 EQUIPMENTS LIST FOR ALL TEST ITEMS

Radiation Test equipment

| Kind of Equipment | Manufacturer | Type No. | Serial No. | Last calibration | Calibrated until |
|--------------------|--------------|------------|------------|------------------|------------------|
| Spectrum Analyzer | Agilent | E4407B | MY50140340 | 2014.10.25 | 2015.10.24 |
| Test Receiver | R&S | ESCI | 101427 | 2014.10.25 | 2015.10.24 |
| Bilog Antenna | TESEQ | CBL6111D | 34678 | 2014.10.27 | 2015.10.26 |
| 50Ω Coaxial Switch | Anritsu | MP59B | 6200264416 | 2014.06.06 | 2015.06.06 |
| Horn Antenna | R&S | 9120D | 152265 | 2014.10.27 | 2015.10.26 |
| Horn Ant | Schwarzbeck | BBHA 9170 | 9170-181 | 2014.07.06 | 2015.07.05 |
| Amplifier | EM | EM-30180 | 060538 | 2014.12.22 | 2015.12.21 |
| Loop Antenna | ARA | PLA-1030/B | 1029 | 2014.06.08 | 2015.06.07 |
| Power Meter | Anritsu | ML2495A | 1204003 | 2014.10.25 | 2015.10.24 |
| Power Sensor | Anritsu | MA2411B | 100309 | 2014.10.25 | 2015.10.24 |

Conduction Test equipment

| Kind of Equipment | Manufacturer | Type No. | Serial No. | Last calibration | Calibrated until |
|-----------------------|--------------|----------|------------|------------------|------------------|
| Test Receiver | R&S | 102086 | 102086 | 2015.10.24 | 2014.10.25 |
| LISN | R&S | ENV216 | 101242 | 2014.10.25 | 2015.10.24 |
| LISN | EMCO | 3810/2NM | 000-23625 | 2014.10.25 | 2015.10.24 |
| 50Ω Coaxial Switch | Anritsu | MP59B | 6200264417 | 2014.06.06 | 2015.06.06 |
| Passive Voltage Probe | R&S | ESH2-Z3 | 100196 | 2014.06.06 | 2015.06.06 |
| Absorbing clamp | R&S | MDS-21 | 100668 | 2014.10.27 | 2015.10.26 |

3. EMC EMISSION TEST

3.1 CONDUCTED EMISSION MEASUREMENT

3.1.1 POWER LINE CONDUCTED EMISSION LIMITS

operating frequency band. In case the emission fall within the restricted band specified on Part 15.247&207(a) limit in the table below has to be followed.

| FREQUENCY (MHz) | Class B (dBuV) | | Standard |
|-----------------|----------------|-----------|----------|
| | Quasi-peak | Average | |
| 0.15 -0.5 | 66 - 56 * | 56 - 46 * | CISPR |
| 0.50 -5.0 | 56.00 | 46.00 | CISPR |
| 5.0 -30.0 | 60.00 | 50.00 | CISPR |

| | | | |
|-----------|-----------|-----------|-----|
| 0.15 -0.5 | 66 - 56 * | 56 - 46 * | FCC |
| 0.50 -5.0 | 56.00 | 46.00 | FCC |
| 5.0 -30.0 | 60.00 | 50.00 | FCC |

Note:

- (1) The tighter limit applies at the band edges.
- (2) The limit of " * " marked band means the limitation decreases linearly with the logarithm of the frequency in the range.

The following table is the setting of the receiver

| Receiver Parameters | Setting |
|---------------------|----------|
| Attenuation | 10 dB |
| Start Frequency | 0.15 MHz |
| Stop Frequency | 30 MHz |
| IF Bandwidth | 9 kHz |

3.2 TEST PROCEDURE

- a. The EUT was placed 0.4 meters from the horizontal ground plane with EUT being connected to the power mains through a line impedance stabilization network (LISN). All other support equipments powered from additional LISN(s). The LISN provide 50 Ohm/ 50uH of coupling impedance for the measuring instrument.
- b. Interconnecting cables that hang closer than 40 cm to the ground plane shall be folded back and forth in the center forming a bundle 30 to 40 cm long.
- c. I/O cables that are not connected to a peripheral shall be bundled in the center. The end of the cable may be terminated, if required, using the correct terminating impedance. The overall length shall not exceed 1 m.
- d. LISN at least 80 cm from nearest part of EUT chassis.
- e. For the actual test configuration, please refer to the related Item –EUT Test Photos.

3.3 TEST SETUP

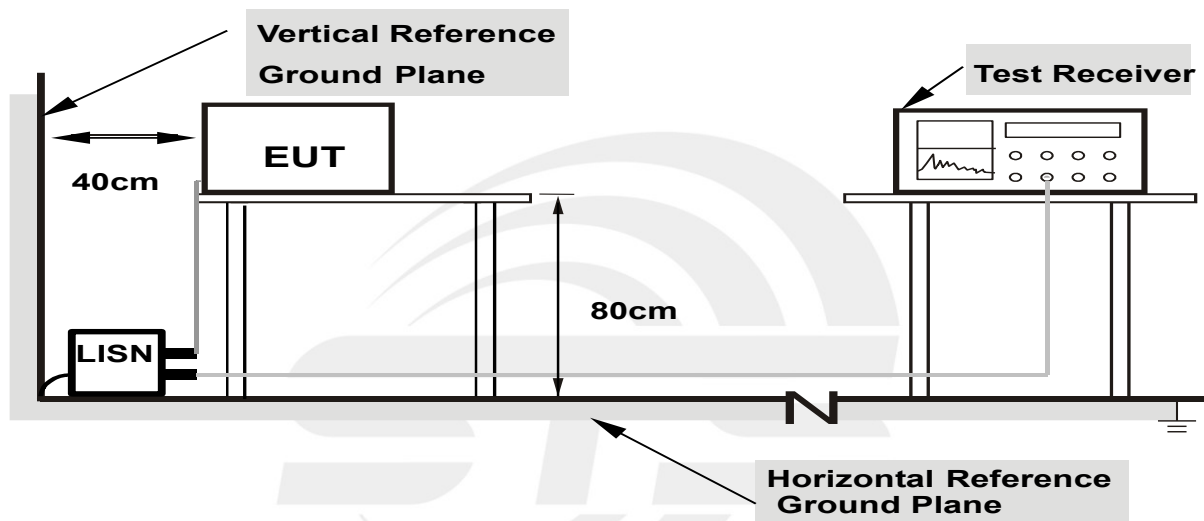

- Note: 1.Support units were connected to second LISN.**
2.Both of LISNs (AMN) are 80 cm from EUT and at least 80 from other units and other metal planes

3.4 EUT OPERATING CONDITIONS

The EUT was configured for testing in a typical fashion (as a customer would normally use it). The EUT has been programmed to continuously transmit during test. This operating condition was tested and used to collect the included data.



3.5 TEST RESULTS

| | | | |
|----------------|---------|---------------------|--------|
| EUT : | T Touch | Model Name. : | HB-04 |
| Temperature : | 26 °C | Relative Humidity : | 54% |
| Pressure : | 1010hPa | Phase : | L |
| Test Voltage : | DC 3.7V | Test Mode : | Mode 2 |

| No. | Frequency (MHz) | Reading (dBuV) | Correct Factor(dB) | Result (dBuV) | Limit (dBuV) | Margin (dB) | Remark |
|-----|--------------------|-------------------|-----------------------|------------------|-----------------|----------------|--------|
| 1 | 0.1565 | 49.52 | 1.22 | 50.74 | 65.65 | -14.91 | QP |
| 2 | 0.1565 | 30.27 | 1.22 | 31.49 | 55.65 | -24.16 | AVG |
| 3 | 0.1980 | 51.73 | 0.80 | 52.53 | 63.69 | -11.16 | QP |
| 4 | 0.1980 | 33.66 | 0.80 | 34.46 | 53.69 | -19.23 | AVG |
| 5 | 0.2420 | 46.62 | 0.80 | 47.42 | 62.03 | -14.61 | QP |
| 6 | 0.2420 | 30.99 | 0.80 | 31.79 | 52.03 | -20.24 | AVG |
| 7 | 4.3220 | 40.29 | 1.00 | 41.29 | 56.00 | -14.71 | QP |
| 8 | 4.3220 | 22.46 | 1.00 | 23.46 | 46.00 | -22.54 | AVG |
| 9 | 13.0220 | 38.81 | 1.00 | 39.81 | 60.00 | -20.19 | QP |
| 10 | 13.0220 | 25.62 | 1.00 | 26.62 | 50.00 | -23.38 | AVG |
| 11 | 16.7780 | 39.20 | 1.00 | 40.20 | 60.00 | -19.80 | QP |
| 12 | 16.7780 | 31.89 | 1.00 | 32.89 | 50.00 | -17.11 | AVG |

Remark:

1. Factor = Antenna Factor + Cable Loss – Pre-amplifier.

100.0 dBuV

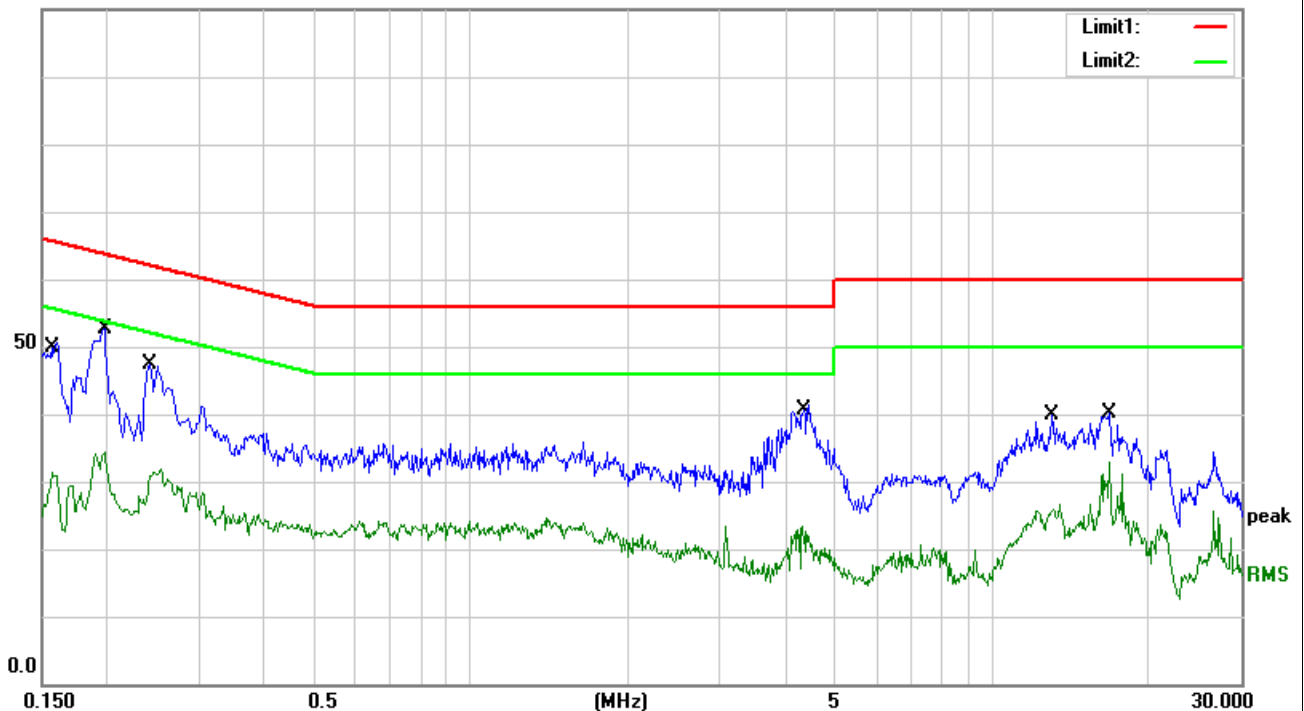



| | | | |
|----------------|---------|---------------------|--------|
| EUT : | T Touch | Model Name. : | HB-04 |
| Temperature : | 26 °C | Relative Humidity : | 54% |
| Pressure : | 1010hPa | Phase : | N |
| Test Voltage : | DC 3.7V | Test Mode : | Mode 2 |

| No. | Frequency (MHz) | Reading (dBUV) | Correct Factor(dB) | Result (dBUV) | Limit (dBUV) | Margin (dB) | Remark |
|-----|-----------------|----------------|--------------------|---------------|--------------|-------------|--------|
| 1 | 0.1580 | 51.03 | 1.04 | 52.07 | 65.57 | -13.50 | QP |
| 2 | 0.1580 | 29.61 | 1.04 | 30.65 | 55.57 | -24.92 | AVG |
| 3 | 0.1860 | 52.45 | 0.80 | 53.25 | 64.21 | -10.96 | QP |
| 4 | 0.1860 | 38.54 | 0.80 | 39.34 | 54.21 | -14.87 | AVG |
| 5 | 0.2430 | 46.49 | 0.80 | 47.29 | 61.99 | -14.70 | QP |
| 6 | 0.2430 | 36.33 | 0.80 | 37.13 | 51.99 | -14.86 | AVG |
| 7 | 0.3780 | 43.44 | 0.80 | 44.24 | 58.32 | -14.08 | QP |
| 8 | 0.3780 | 30.37 | 0.80 | 31.17 | 48.32 | -17.15 | AVG |
| 9 | 11.5260 | 37.87 | 1.00 | 38.87 | 60.00 | -21.13 | QP |
| 10 | 11.5260 | 25.20 | 1.00 | 26.20 | 50.00 | -23.80 | AVG |
| 11 | 14.7780 | 38.40 | 1.00 | 39.40 | 60.00 | -20.60 | QP |
| 12 | 14.7780 | 25.91 | 1.00 | 26.91 | 50.00 | -23.09 | AVG |

Remark:

1. Factor = Antenna Factor + Cable Loss – Pre-amplifier.

100.0 dBUV

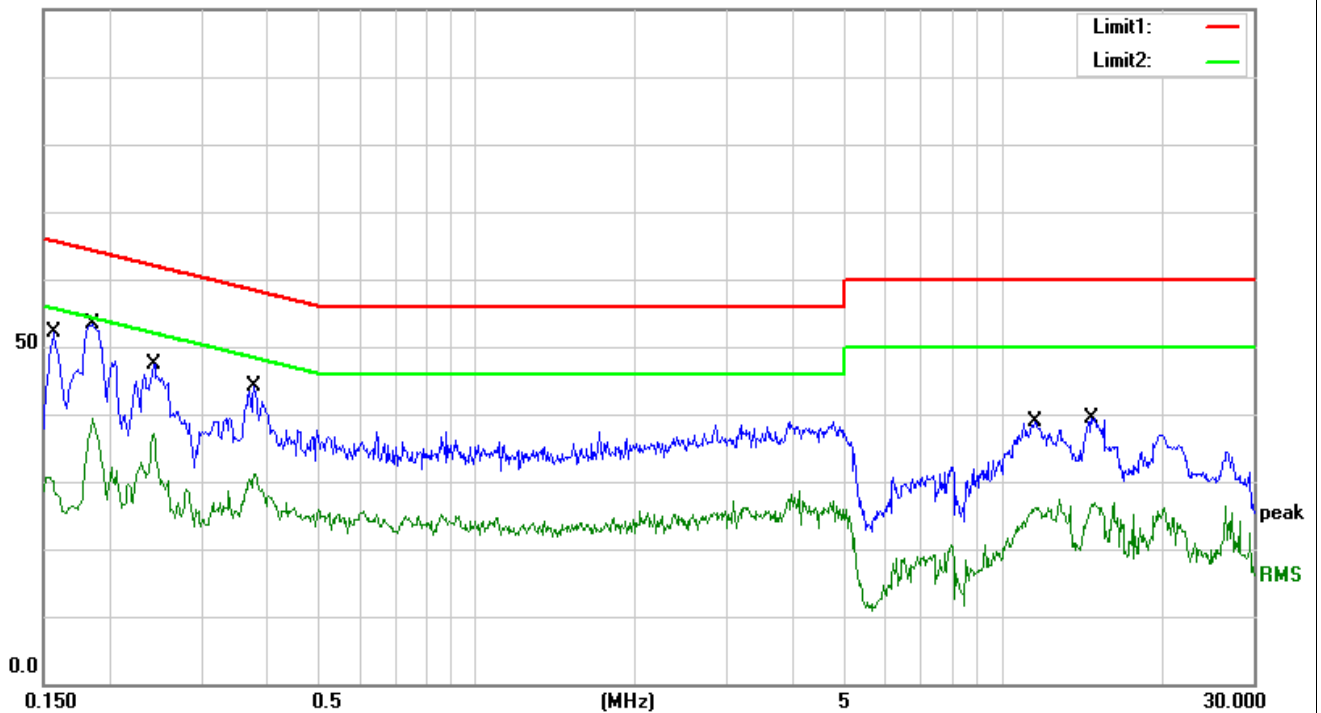

4. RADIATED EMISSION MEASUREMENT

4.1 RADIATED EMISSION LIMITS

6dBc in any 100 kHz bandwidth outside the operating frequency band. In case the emission fall within the restricted band specified on Part 15.247&205(a), then the Part15.247&209(a) limit in the table below has to be followed.

LIMITS OF RADIATED EMISSION MEASUREMENT (Frequency Range 9kHz-1000MHz)

| Frequencies (MHz) | Field Strength (micorvolts/meter) | Measurement Distance (meters) |
|-------------------|-----------------------------------|-------------------------------|
| 0.009~0.490 | 2400/F(KHz) | 300 |
| 0.490~1.705 | 24000/F(KHz) | 30 |
| 1.705~30.0 | 30 | 30 |
| 30~88 | 100 | 3 |
| 88~216 | 150 | 3 |
| 216~960 | 200 | 3 |
| Above 960 | 500 | 3 |

LIMITS OF RADIATED EMISSION MEASUREMENT (Above 1000MHz)

| FREQUENCY (MHz) | Class B (dBuV/m) (at 3M) | |
|-----------------|--------------------------|---------|
| | PEAK | AVERAGE |
| Above 1000 | 74 | 54 |

Notes:

- (1) The limit for radiated test was performed according to FCC PART 15C.
- (2) The tighter limit applies at the band edges.
- (3) Emission level (dBuV/m)=20log Emission level (uV/m).

| Spectrum Parameter | Setting |
|---------------------------------------|--------------------------------|
| Attenuation | Auto |
| Detector | Peak |
| Start Frequency | 1000 MHz(Peak/AV) |
| Stop Frequency | 10th carrier harmonic(Peak/AV) |
| RB / VB (emission in restricted band) | 1 MHz / 1 MHz, AV=1 MHz / 10Hz |

| Receiver Parameter | Setting |
|------------------------|----------------------------------|
| Attenuation | Auto |
| Start ~ Stop Frequency | 9kHz~150kHz / RB 200Hz for QP |
| Start ~ Stop Frequency | 150kHz~30MHz / RB 9kHz for QP |
| Start ~ Stop Frequency | 30MHz~1000MHz / RB 120kHz for QP |



4.2 TEST PROCEDURE

- a. The measuring distance of at 3 m shall be used for measurements at frequency up to 1GHz. For frequencies above 1GHz, any suitable measuring distance may be used.
- b. The EUT was placed on the top of a rotating table 0.8 meters above the ground at a 3 meter open area test site. The table was rotated 360 degrees to determine the position of the highest radiation.
- c. The height of the equipment or of the substitution antenna shall be 0.8 m; the height of the test antenna shall vary between 1 m to 4 m. Both horizontal and vertical polarizations of the antenna are set to make the measurement.
- d. The initial step in collecting conducted emission data is a spectrum analyzer peak detector mode pre-scanning the measurement frequency range. Significant peaks are then marked and then Quasi Peak detector mode re-measured.
- e. If the Peak Mode measured value compliance with and lower than Quasi Peak Mode Limit, the EUT shall be deemed to meet QP Limits and then no additional QP Mode measurement performed.
- f. For the actual test configuration, please refer to the related Item –EUT Test Photos.

Note:

Both horizontal and vertical antenna polarities were tested and performed pretest to three orthogonal axis. The worst case emissions were reported

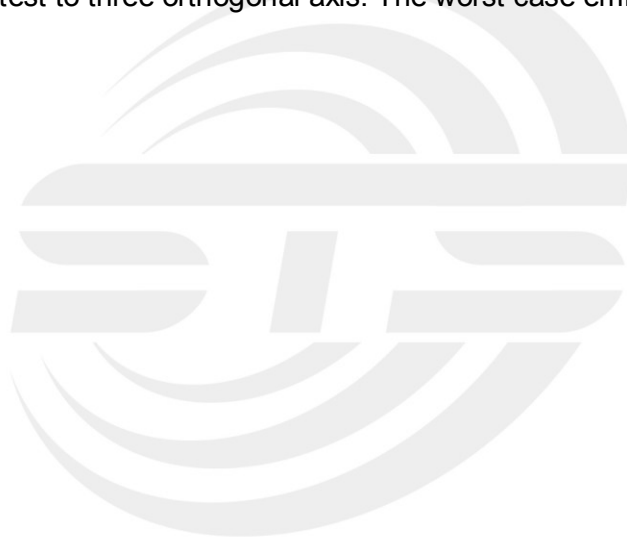

4.3 TEST SETUP

(A) Radiated Emission Test-Up Frequency Below 30MHz

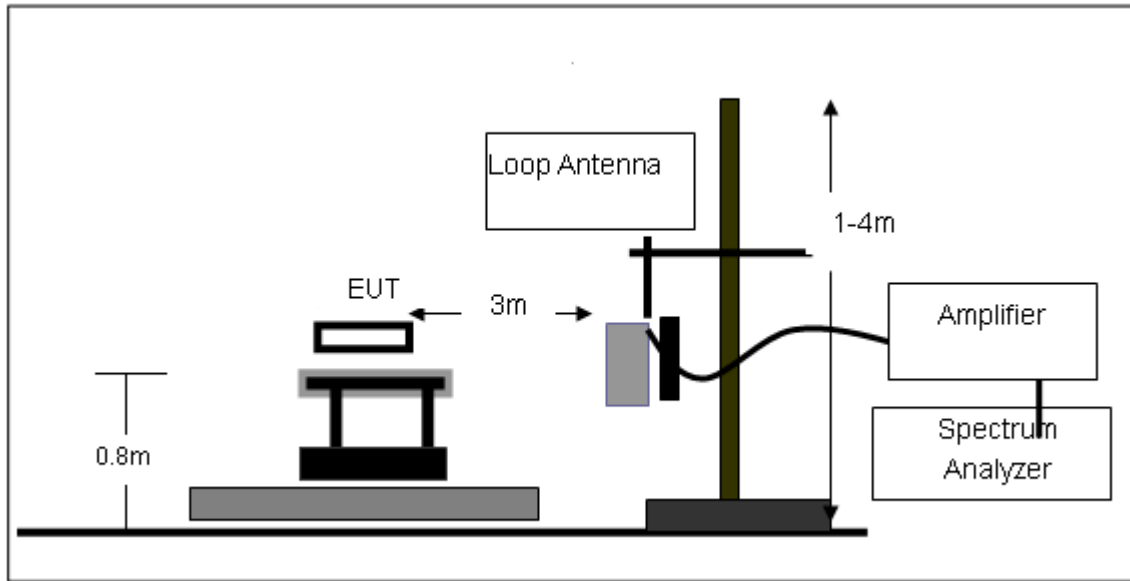

(B) Radiated Emission Test-Up Frequency 30MHz~1GHz

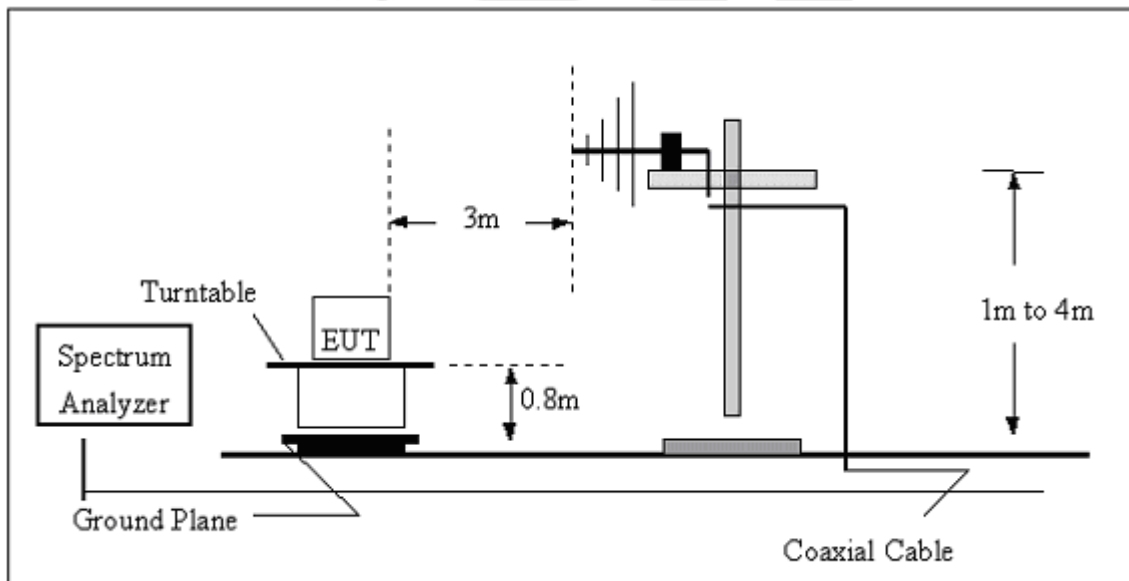

(C) Radiated Emission Test-Up Frequency Above 1GHz

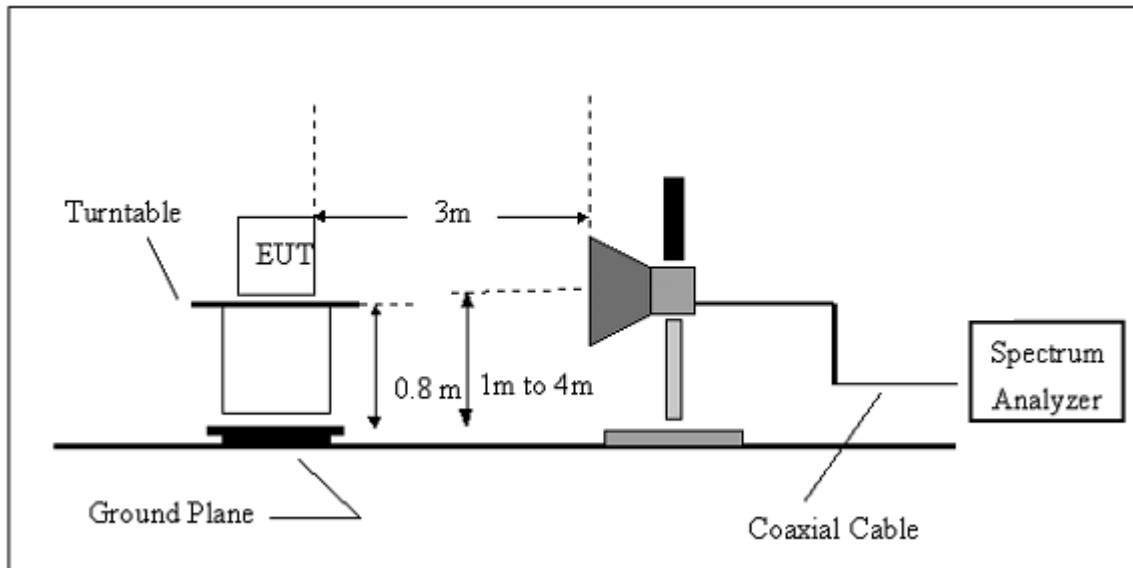

4.4 EUT OPERATING CONDITIONS

The EUT tested system was configured as the statements of 2.3 Unless otherwise a special operating condition is specified in the follows during the testing.



4.5 TEST RESULTS

(Between 9KHz – 30 MHz)

| | | | |
|--------------|-----------|--------------------|---------|
| EUT: | T Touch | Model Name. : | HB-04 |
| Temperature: | 20 °C | Relative Humidity: | 48% |
| Pressure: | 1010 hPa | Test Voltage : | DC 3.7V |
| Test Mode : | Link mode | Polarization : | -- |

| Freq. (MHz) | Reading (dBuV/m) | Limit (dBuV/m) | Margin (dB) | State P/F |
|----------------|---------------------|-------------------|----------------|--------------|
| -- | -- | -- | -- | PASS |
| -- | -- | -- | -- | PASS |

NOTE:

The amplitude of spurious emissions which are attenuated by more than 20dB below the permissible value has no need to be reported.

Distance extrapolation factor = $40 \log(\text{specific distance}/\text{test distance})(\text{dB})$;

Limit line = specific limits(dBuv) + distance extrapolation factor.

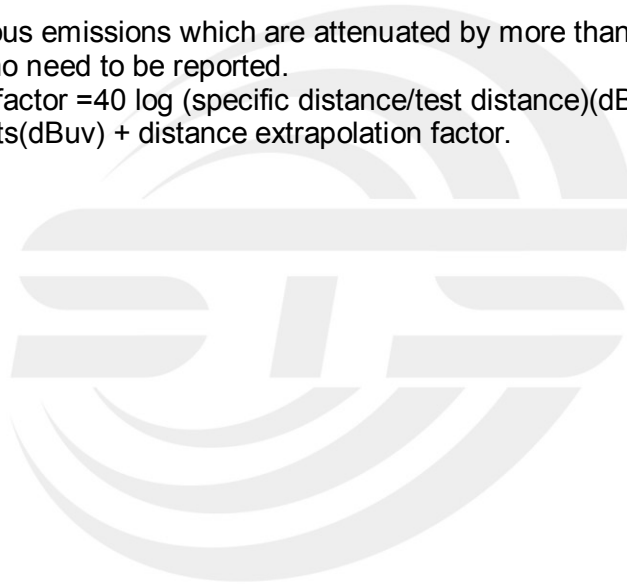



Between 30MHz – 1GHz

| | | | |
|---------------|-----------|---------------------|------------|
| EUT : | T Touch | Model Name : | HB-04 |
| Temperature : | 20 °C | Relative Humidity : | 48% |
| Pressure : | 1010 hPa | Test Voltage : | DC 3.7V |
| Test Mode : | Link mode | Polarization : | Horizontal |

| No. | Frequency (MHz) | Reading (dBUV) | Correct Factor(dB/m) | Result (dBUV/m) | Limit (dBUV/m) | Margin (dB) | Remark |
|-----|-----------------|----------------|----------------------|-----------------|----------------|-------------|--------|
| 1 | 31.0706 | 5.96 | 18.39 | 24.35 | 40.00 | -15.65 | QP |
| 2 | 55.4147 | 12.07 | 6.47 | 18.54 | 40.00 | -21.46 | QP |
| 3 | 82.6482 | 12.40 | 8.53 | 20.93 | 40.00 | -19.07 | QP |
| 4 | 137.9028 | 7.70 | 12.87 | 20.57 | 43.50 | -22.93 | QP |
| 5 | 190.4050 | 9.38 | 9.49 | 18.87 | 43.50 | -24.63 | QP |
| 6 | 271.3246 | 4.30 | 14.80 | 19.10 | 46.00 | -26.90 | QP |

Remark:

1. Factor = Antenna Factor + Cable Loss – Pre-amplifier.

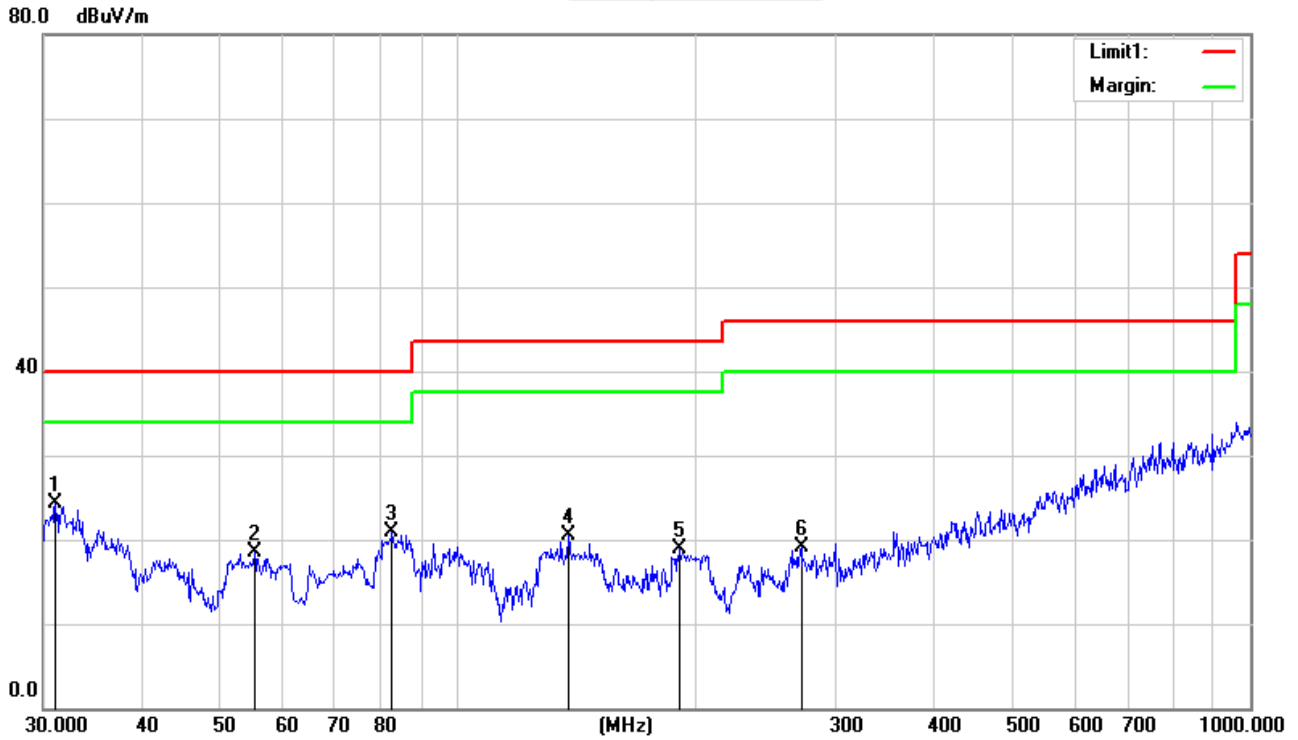



| | | | |
|---------------|-----------|---------------------|----------|
| EUT : | T Touch | Model Name : | HB-04 |
| Temperature : | 20 °C | Relative Humidity : | 48% |
| Pressure : | 1010 hPa | Test Voltage : | DC 3.7V |
| Test Mode : | Link mode | Polarization : | Vertical |

| No. | Frequency (MHz) | Reading (dBuV) | Correct Factor(dB/m) | Result (dBuV/m) | Limit (dBuV/m) | Margin (dB) | Remark |
|-----|-----------------|----------------|----------------------|-----------------|----------------|-------------|--------|
| 1 | 32.5198 | 7.37 | 17.66 | 25.03 | 40.00 | -14.97 | QP |
| 2 | 46.3402 | 6.53 | 10.37 | 16.90 | 40.00 | -23.10 | QP |
| 3 | 68.6310 | 8.99 | 6.24 | 15.23 | 40.00 | -24.77 | QP |
| 4 | 139.8508 | 7.65 | 12.89 | 20.54 | 43.50 | -22.96 | QP |
| 5 | 269.4284 | 4.34 | 14.88 | 19.22 | 46.00 | -26.78 | QP |
| 6 | 375.9385 | 8.84 | 17.63 | 26.47 | 46.00 | -19.53 | QP |

Remark:

- Factor = Antenna Factor + Cable Loss – Pre-amplifier.

80.0 dBuV/m

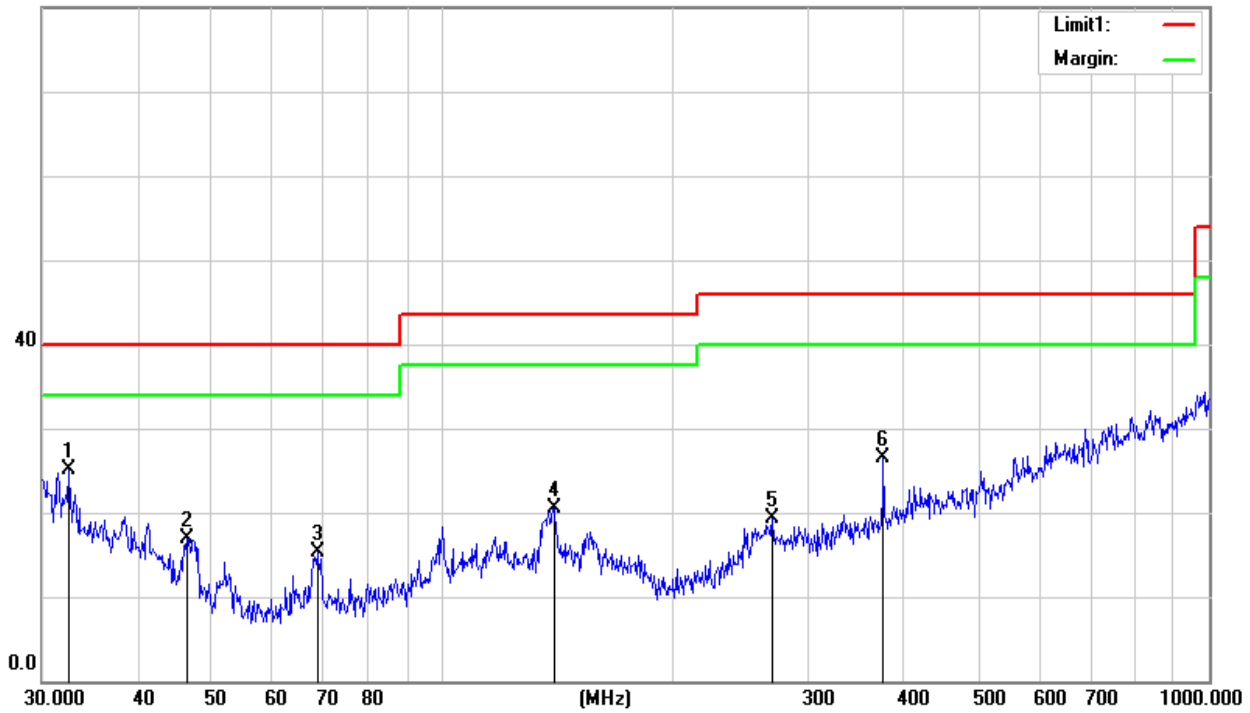



Above 1000 MHz

| | | | |
|---------------|----------------------|---------------------|------------|
| EUT : | T Touch | Model Name : | HB-04 |
| Temperature : | 20 °C | Relative Humidity : | 48% |
| Pressure : | 1010 hPa | Test Voltage : | DC 3.7V |
| Test Mode : | TX Mode /CH1:2402MHz | Polarization : | Horizontal |

| Frequency (MHz) | Meter Reading (dBμV) | Factor (dB) | Emission Level (dBμV/m) | Limits (dBμV/m) | Margin (dB) | Value Type |
|--------------------|-------------------------|----------------|----------------------------|--------------------|----------------|------------|
| 4804 | 43.34 | 10.44 | 53.78 | 74 | -20.22 | peak |
| 4804 | 32.45 | 10.44 | 42.89 | 54 | -11.11 | AVG |
| 7206 | 41.23 | 12.39 | 53.62 | 74 | -20.38 | peak |
| 7206 | 31.67 | 12.39 | 44.06 | 54 | -9.94 | AVG |
| | | | | | | |
| | | | | | | |

Remark:

Factor = Antenna Factor + Cable Loss – Pre-amplifier.

| | | | |
|---------------|----------------------|---------------------|----------|
| EUT : | T Touch | Model Name : | HB-04 |
| Temperature : | 20 °C | Relative Humidity : | 48% |
| Pressure : | 1010 hPa | Test Voltage : | DC 3.7V |
| Test Mode : | TX Mode /CH1:2402MHz | Polarization : | Vertical |

| Frequency (MHz) | Meter Reading (dBμV) | Factor (dB) | Emission Level (dBμV/m) | Limits (dBμV/m) | Margin (dB) | Value Type |
|--------------------|-------------------------|----------------|----------------------------|--------------------|----------------|------------|
| 4804 | 41.37 | 10.4 | 51.77 | 74 | -22.23 | peak |
| 4804 | 29.73 | 10.4 | 40.13 | 54 | -13.87 | AVG |
| 7206 | 31.41 | 12.75 | 44.16 | 74 | -29.84 | peak |
| 7206 | 25.67 | 12.75 | 38.42 | 54 | -15.58 | AVG |
| | | | | | | |
| | | | | | | |

Remark:

Factor = Antenna Factor + Cable Loss – Pre-amplifier.



| | | | |
|---------------|-----------------------|---------------------|------------|
| EUT : | T Touch | Model Name : | HB-04 |
| Temperature : | 20 °C | Relative Humidity : | 48% |
| Pressure : | 1010 hPa | Test Voltage : | DC 3.7V |
| Test Mode : | TX Mode /CH20:2440MHz | Polarization : | Horizontal |

| Frequency (MHz) | Meter Reading (dB μ V) | Factor (dB) | Emission Level (dB μ V/m) | Limits (dB μ V/m) | Margin (dB) | Value Type |
|--------------------|-------------------------------|----------------|----------------------------------|--------------------------|----------------|------------|
| 4880 | 43.65 | 10.4 | 54.05 | 74 | -19.95 | peak |
| 4880 | 32.31 | 10.4 | 42.71 | 54 | -11.29 | AVG |
| 7320 | 41.72 | 12.75 | 54.47 | 74 | -19.53 | peak |
| 7320 | 32.56 | 12.75 | 45.31 | 54 | -8.69 | AVG |
| | | | | | | |
| | | | | | | |

Remark:

Factor = Antenna Factor + Cable Loss – Pre-amplifier.

| | | | |
|---------------|-----------------------|---------------------|----------|
| EUT : | T Touch | Model Name : | HB-04 |
| Temperature : | 20 °C | Relative Humidity : | 48% |
| Pressure : | 1010 hPa | Test Voltage : | DC 3.7V |
| Test Mode : | TX Mode /CH20:2440MHz | Polarization : | Vertical |

| Frequency (MHz) | Meter Reading (dB μ V) | Factor (dB) | Emission Level (dB μ V/m) | Limits (dB μ V/m) | Margin (dB) | Value Type |
|--------------------|-------------------------------|----------------|----------------------------------|--------------------------|----------------|------------|
| 4880 | 45.56 | 10.39 | 55.95 | 74 | -18.05 | peak |
| 4880 | 32.67 | 10.44 | 43.11 | 54 | -10.89 | AVG |
| 7320 | 32.23 | 12.68 | 44.91 | 74 | -29.09 | peak |
| 7320 | 32.78 | 12.68 | 45.46 | 54 | -8.54 | AVG |
| | | | | | | |
| | | | | | | |

Remark:

- Factor = Antenna Factor + Cable Loss – Pre-amplifier.
- No emission detected above 18GHz



| | | | |
|---------------|-----------------------|---------------------|------------|
| EUT : | T Touch | Model Name : | HB-04 |
| Temperature : | 20 °C | Relative Humidity : | 48% |
| Pressure : | 1010 hPa | Test Voltage : | DC 3.7V |
| Test Mode : | TX Mode /CH40:2480MHz | Polarization : | Horizontal |

| Frequency (MHz) | Meter Reading (dB μ V) | Factor (dB) | Emission Level (dB μ V/m) | Limits (dB μ V/m) | Margin (dB) | Value Type |
|--------------------|-------------------------------|----------------|----------------------------------|--------------------------|----------------|------------|
| 4960 | 36.83 | 10.39 | 47.22 | 74 | -26.78 | peak |
| 4960 | 25.32 | 10.39 | 35.71 | 54 | -18.29 | AVG |
| 7440 | 42.46 | 12.68 | 55.14 | 74 | -18.86 | peak |
| 7440 | 31.69 | 12.68 | 44.37 | 54 | -9.63 | AVG |
| | | | | | | |
| | | | | | | |

Remark:

1 Factor = Antenna Factor + Cable Loss – Pre-amplifier.

2 No emission detected above 18GHz

| | | | |
|---------------|-----------------------|---------------------|----------|
| EUT : | T Touch | Model Name : | HB-04 |
| Temperature : | 20 °C | Relative Humidity : | 48% |
| Pressure : | 1010 hPa | Test Voltage : | DC 3.7V |
| Test Mode : | TX Mode /CH40:2480MHz | Polarization : | Vertical |

| Frequency (MHz) | Meter Reading (dB μ V) | Factor (dB) | Emission Level (dB μ V/m) | Limits (dB μ V/m) | Margin (dB) | Value Type |
|--------------------|-------------------------------|----------------|----------------------------------|--------------------------|----------------|------------|
| 4960 | 45.89 | 10.39 | 56.28 | 74 | -17.72 | peak |
| 4960 | 34.61 | 10.39 | 45 | 54 | -9 | AVG |
| 7440 | 44.54 | 12.68 | 57.22 | 74 | -16.78 | peak |
| 7440 | 25.69 | 12.68 | 38.37 | 54 | -15.63 | AVG |
| | | | | | | |
| | | | | | | |

Remark:

1 Factor = Antenna Factor + Cable Loss – Pre-amplifier.

2 No emission detected above 18GHz



4.6 TEST RESULTS (RESTRICTED BANDS REQUIREMENTS)

| | | | |
|---------------|---------------------|---------------------|----------|
| EUT : | T Touch | Model Name : | HB-04 |
| Temperature : | 20 °C | Relative Humidity : | 48% |
| Pressure : | 1010 hPa | Test Voltage : | DC 3.7V |
| Test Mode : | TX Mode /CH00: 2402 | Polarization : | Vertical |

| Frequency (MHz) | Meter Reading (dB μ V) | Factor (dB) | Emission Level (dB μ V/m) | Limits (dB μ V/m) | Margin (dB) | Detector Type | Comment |
|--------------------|-------------------------------|----------------|----------------------------------|--------------------------|----------------|------------------|----------|
| GFSK | | | | | | | |
| 2399.9 | 77.54 | -13 | 64.54 | 74 | -9.46 | peak | Vertical |
| 2399.9 | 55.58 | -13 | 42.58 | 54 | -11.42 | AVG | Vertical |
| 2400 | 78.73 | -12.99 | 65.74 | 74 | -8.26 | peak | Vertical |
| 2400 | 56.96 | -12.99 | 43.97 | 54 | -10.03 | AVG | Vertical |
| | | | | | | | |

| | | | |
|---------------|---------------------|---------------------|----------|
| EUT : | T Touch | Model Name : | HB-04 |
| Temperature : | 20 °C | Relative Humidity : | 48% |
| Pressure : | 1010 hPa | Test Voltage : | DC 3.7V |
| Test Mode : | TX Mode /CH40: 2480 | Polarization : | Vertical |

| Frequency (MHz) | Meter Reading (dB μ V) | Factor (dB) | Emission Level (dB μ V/m) | Limits (dB μ V/m) | Margin (dB) | Detector Type | Comment |
|--------------------|-------------------------------|----------------|----------------------------------|--------------------------|----------------|------------------|----------|
| GFSK | | | | | | | |
| 2483.5 | 78.26 | -12.78 | 65.48 | 74 | -8.52 | peak | Vertical |
| 2483.5 | 56.67 | -12.78 | 43.89 | 54 | -10.11 | AVG | Vertical |
| 2483.6 | 78.88 | -12.77 | 66.11 | 74 | -7.89 | peak | Vertical |
| 2483.6 | 55.51 | -12.77 | 42.74 | 54 | -11.26 | AVG | Vertical |
| | | | | | | | |

5. CONDUCTED SPURIOUS EMISSIONS

5.1 REQUIREMENT

According to FCC section 15.247(d), in any 100kHz bandwidth outside the frequency band in which the spread spectrum or digitally modulated intentional radiator is operating, the radio frequency power that is produced by the intentional radiator shall be at least 20dB below that in the 100kHz bandwidth within the band that contains the highest level of the desired power, based on either an RF conducted or a radiated measurement.

5.2 TEST PROCEDURE

According to FCC section 15.247(d), in any 100kHz bandwidth outside the frequency band in which the spread spectrum or digitally modulated intentional radiator is operating, the radio frequency power that is produced by the intentional radiator shall be at least 20dB below that in the 100kHz bandwidth within the band that contains the highest level of the desired power, based on either an RF conducted or a radiated measurement.

| Spectrum Parameter | Setting |
|---------------------------------------|---------------------------------|
| Detector | Peak |
| Start/Stop Frequency | 30 MHz to 10th carrier harmonic |
| RB / VB (emission in restricted band) | 100 KHz/300 KHz |
| Trace-Mode: | Max hold |

For Band edge

| Spectrum Parameter | Setting |
|---------------------------------------|--|
| Detector | Peak |
| Start/Stop Frequency | Lower Band Edge: 2310 – 2404 MHz Upper Band Edge: 2478 – 2500 MHz |
| RB / VB (emission in restricted band) | 100 KHz/300 KHz |
| Trace-Mode: | Max hold |

5.3 TEST SETUP

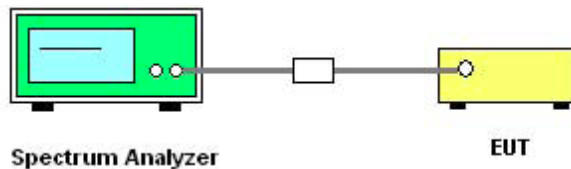

The EUT which is powered by the Battery, is coupled to the Spectrum Analyzer; the RF load attached to the EUT antenna terminal is 50Ohm; the path loss as the factor is calibrated to correct the reading. Make the measurement with the spectrum analyzer's resolution bandwidth(RBW) = 100 kHz. In order to make an accurate measurement, set the span greater than RBW.

5.4 EUT OPERATION CONDITIONS

The EUT tested system was configured as the statements of 2.3 Unless otherwise a special operating condition is specified in the follows during the testing.



5.5 TEST RESULTS

| | | | |
|---------------|---------------------------|---------------------|---------|
| EUT : | T Touch | Model Name : | HB-04 |
| Temperature : | 25 °C | Relative Humidity : | 50% |
| Pressure : | 1012 hPa | Test Voltage : | DC 3.7V |
| Test Mode : | TX Mode /CH02, CH20, CH40 | | |

00 CH

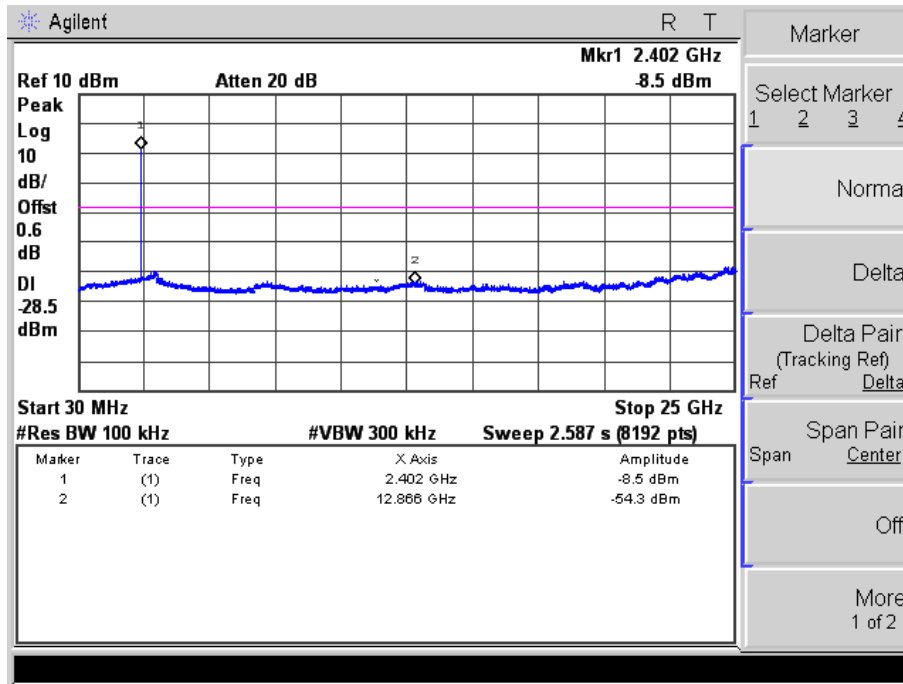

20 CH

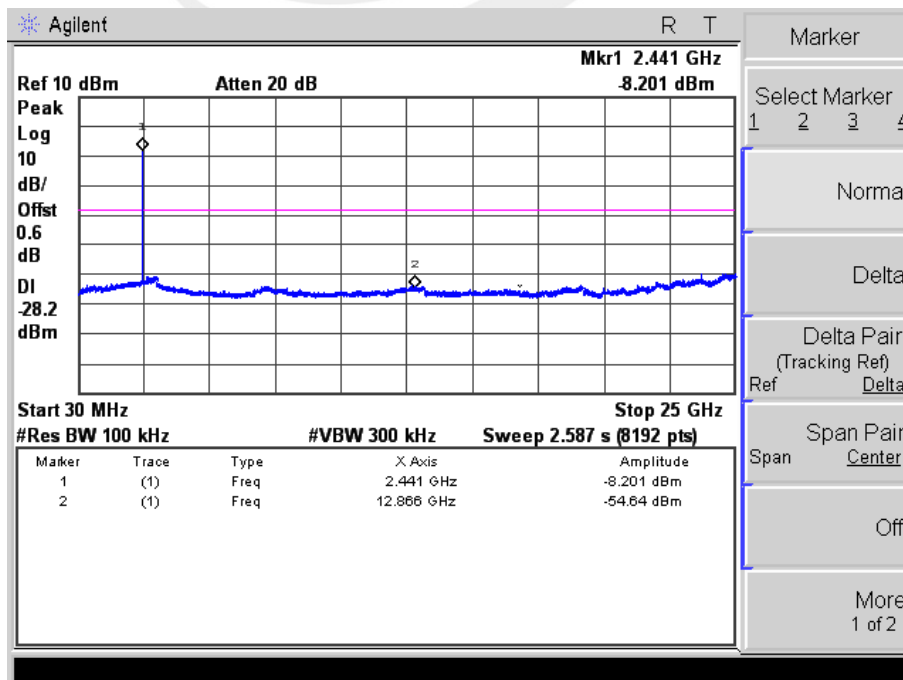



For Band edge

00 Channel

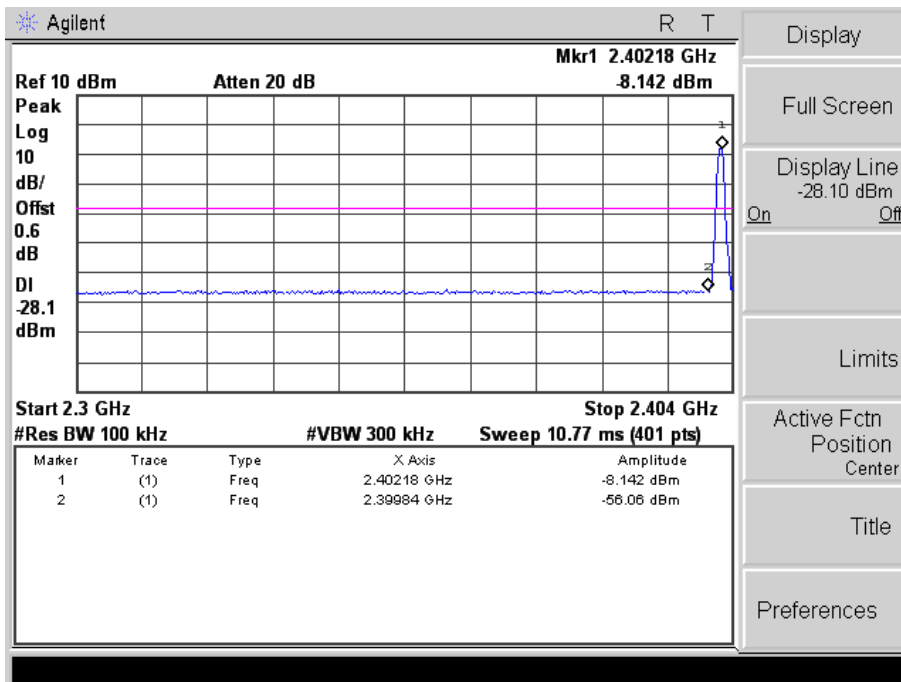

40 Channel

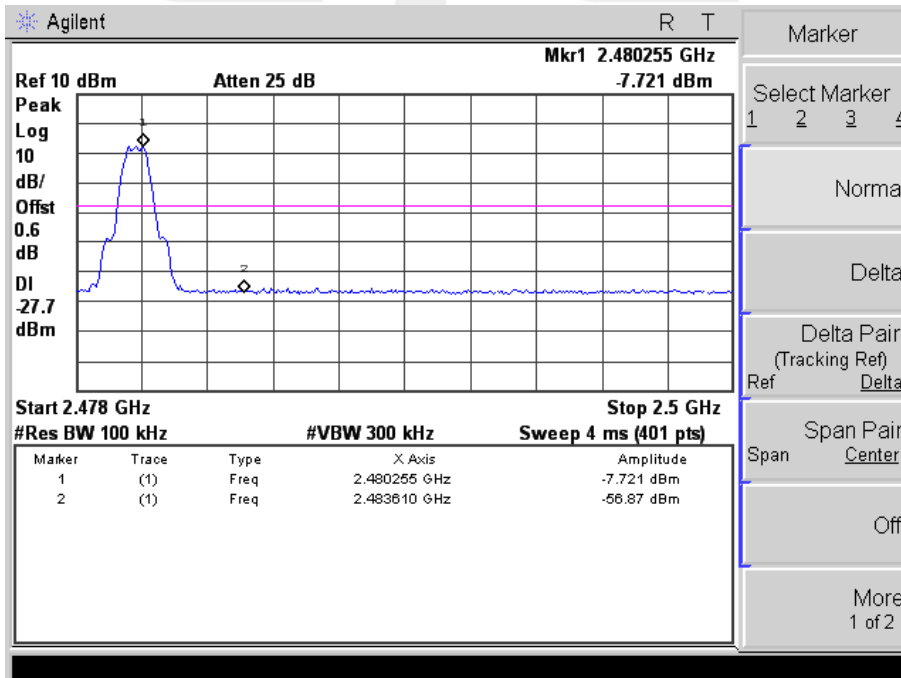

6. POWER SPECTRAL DENSITY TEST

6.1 APPLIED PROCEDURES / LIMIT

| FCC Part15 (15.247) , Subpart C | | | | |
|---------------------------------|------------------------|------------------------|-----------------------|--------|
| Section | Test Item | Limit | Frequency Range (MHz) | Result |
| 15.247 | Power Spectral Density | 8 dBm (in any 3KHz) | 2400-2483.5 | PASS |

6.2 TEST PROCEDURE

1. Set analyzer center frequency to DTS channel center frequency.
2. Set the span to 1.5 times the DTS channel bandwidth.
3. Set the RBW \geq 3 kHz.
4. Set the VBW \geq 3 x RBW.
5. Detector = peak.
6. Sweep time = auto couple.
7. Trace mode = max hold.
8. Allow trace to fully stabilize.
9. Use the peak marker function to determine the maximum amplitude level.
10. If measured value exceeds limit, reduce RBW (no less than 3 kHz) and repeat.

6.3 TEST SETUP

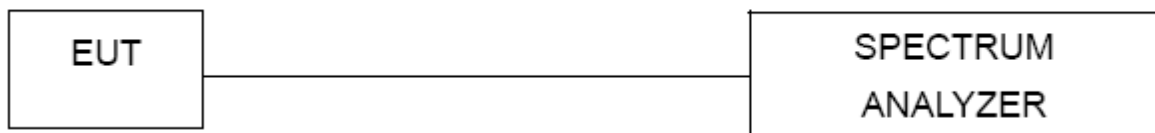

6.4 EUT OPERATION CONDITIONS

The EUT tested system was configured as the statements of 2.3 Unless otherwise a special operating condition is specified in the follows during the testing.



6.5 TEST RESULTS

| | | | |
|---------------|---------------------------|---------------------|---------|
| EUT : | T Touch | Model Name : | HB-04 |
| Temperature : | 25 °C | Relative Humidity : | 60% |
| Pressure : | 1015 hPa | Test Voltage : | DC 3.7V |
| Test Mode : | TX Mode /CH02, CH20, CH40 | | |

| Frequency | Power Density (dBm) | Limit (dBm) | Result |
|-----------|---------------------|-------------|--------|
| 2402 MHz | -22.19 | 8 | PASS |
| 2440 MHz | -21.07 | 8 | PASS |
| 2480 MHz | -21.52 | 8 | PASS |

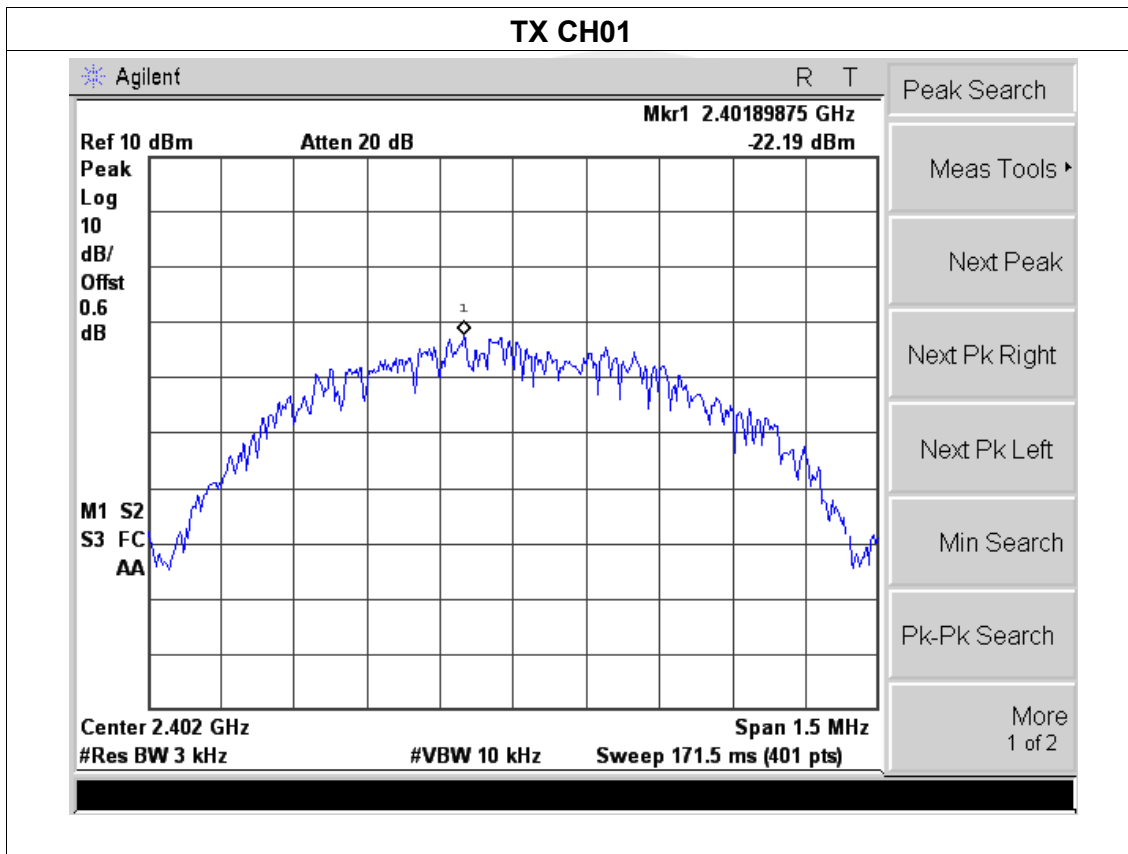

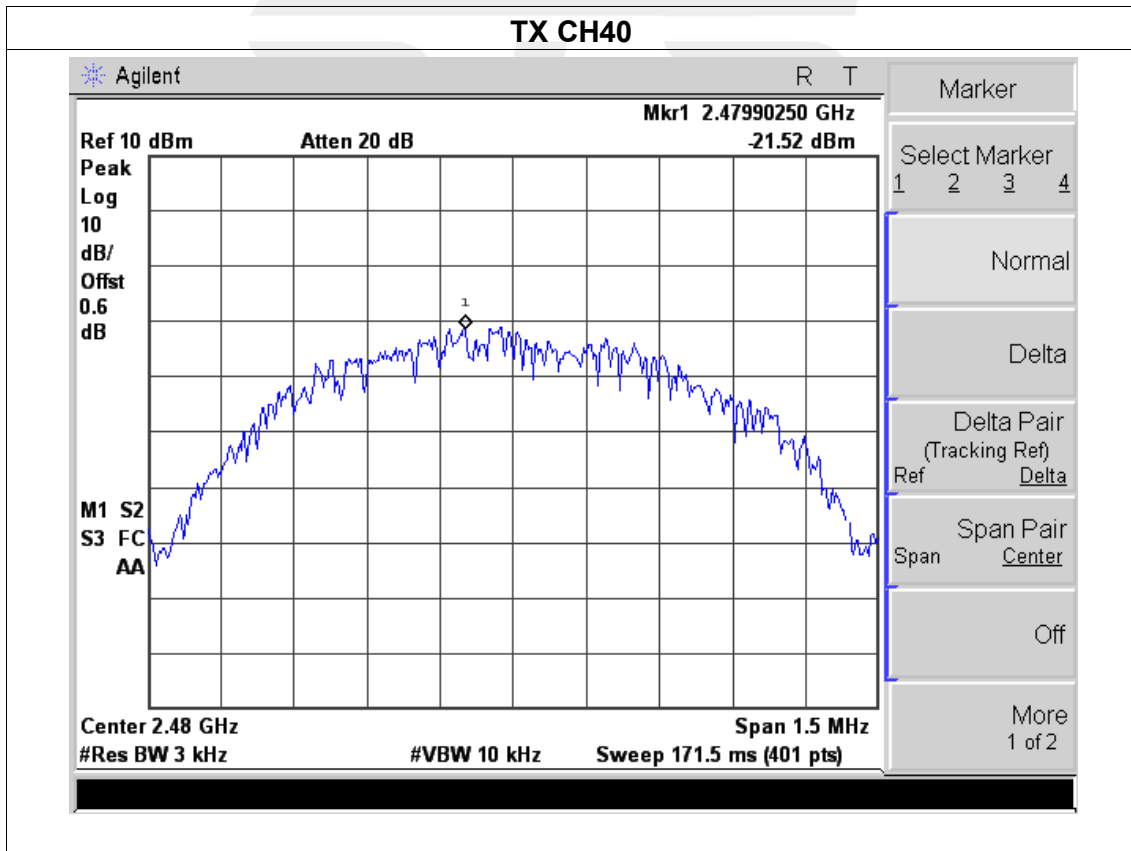
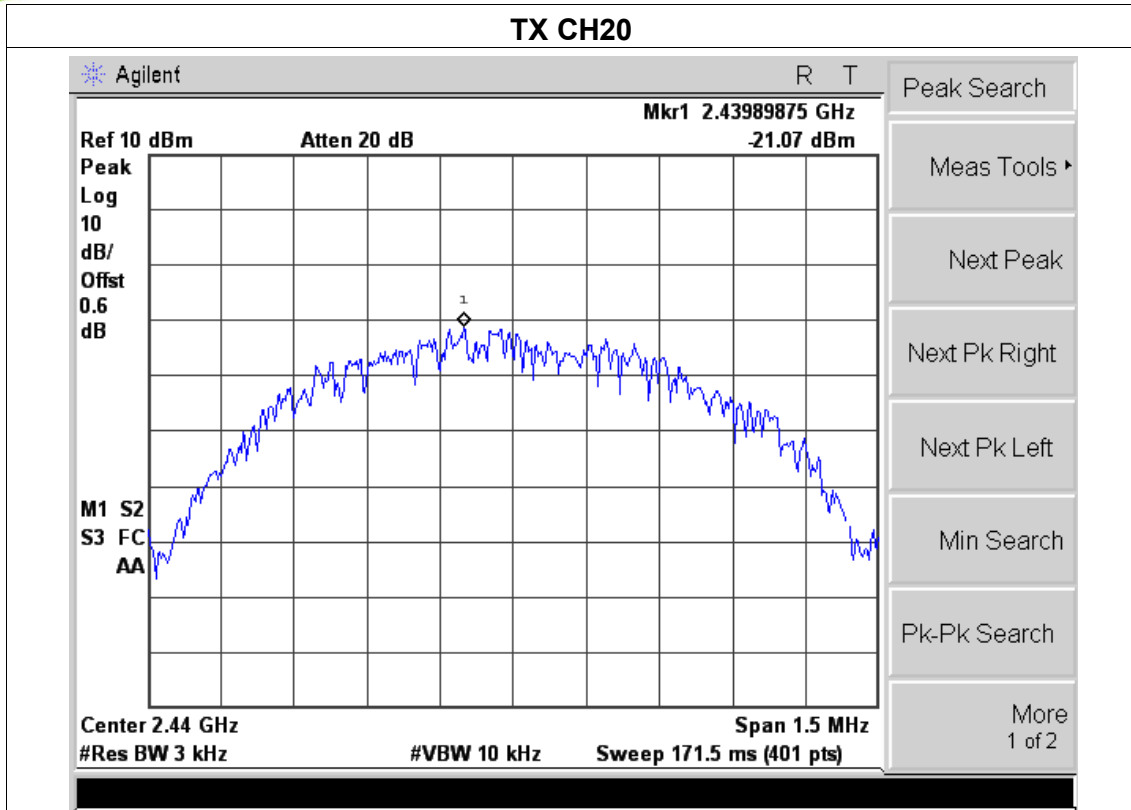

7. BANDWIDTH TEST

7.1 APPLIED PROCEDURES / LIMIT

| FCC Part15 (15.247) , Subpart C | | | | |
|---------------------------------|-----------|---|-----------------------|--------|
| Section | Test Item | Limit | Frequency Range (MHz) | Result |
| 15.247(a)(2) | Bandwidth | $\geq 500\text{KHz}$ (6dB bandwidth) | 2400-2483.5 | PASS |

7.2 TEST PROCEDURE

1. Set RBW = 100 kHz.
2. Set the video bandwidth (VBW) $\geq 3 \times$ RBW.
3. Detector = Peak.
4. Trace mode = max hold.
5. Sweep = auto couple.
6. Allow the trace to stabilize.
7. Measure the maximum width of the emission that is constrained by the frequencies associated with the two outermost amplitude points (upper and lower frequencies) that are attenuated by 6 dB relative to the maximum level measured in the fundamental emission.

7.3 TEST SETUP

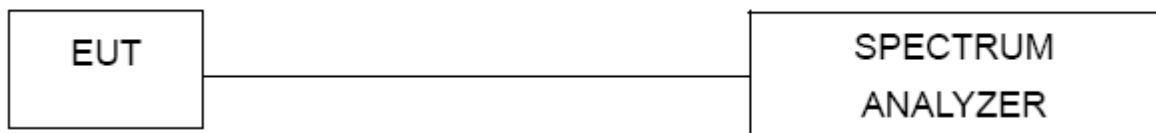

7.4 EUT OPERATION CONDITIONS

The EUT tested system was configured as the statements of 2.3 Unless otherwise a special operating condition is specified in the follows during the testing.



7.5 TEST RESULTS

| | | | |
|---------------|---------------------------|---------------------|---------|
| EUT : | T Touch | Model Name : | HB-04 |
| Temperature : | 25 °C | Relative Humidity : | 60% |
| Pressure : | 1012 hPa | Test Voltage : | DC 3.7V |
| Test Mode : | TX Mode /CH01, CH20, CH40 | | |

| Frequency | 6dB Bandwidth (MHz) | Channel Separation (KHz) | Result |
|-----------|---------------------|--------------------------|-------------|
| 2402 MHz | 0.736 | >=500KHz | PASS |
| 2440 MHz | 0.732 | >=500KHz | PASS |
| 2480 MHz | 0.733 | >=500KHz | PASS |

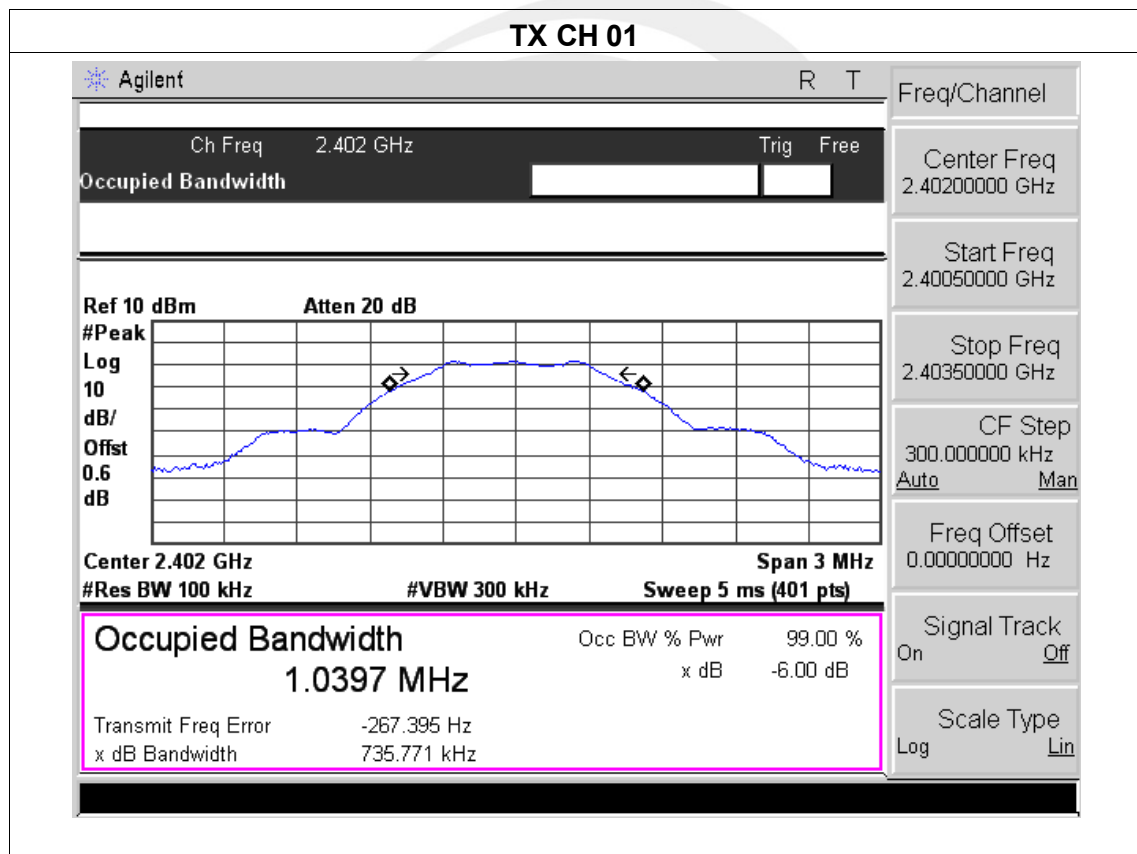

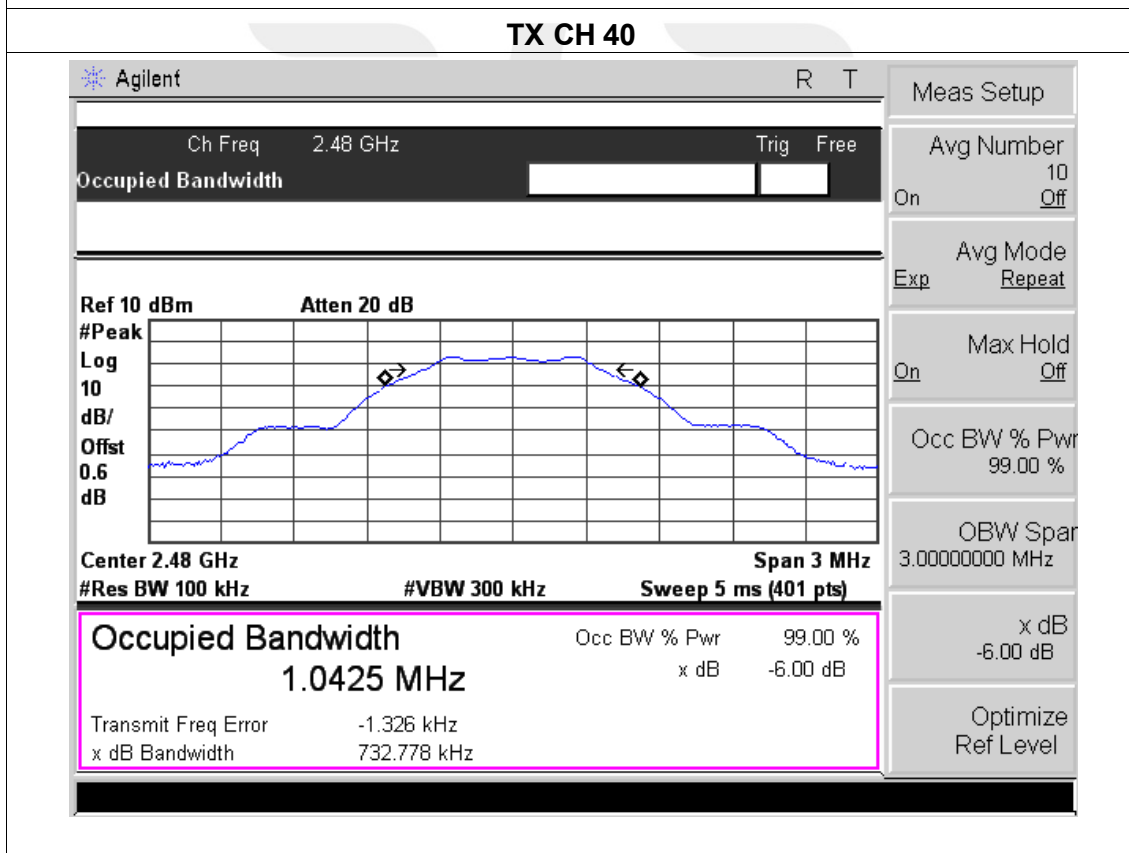
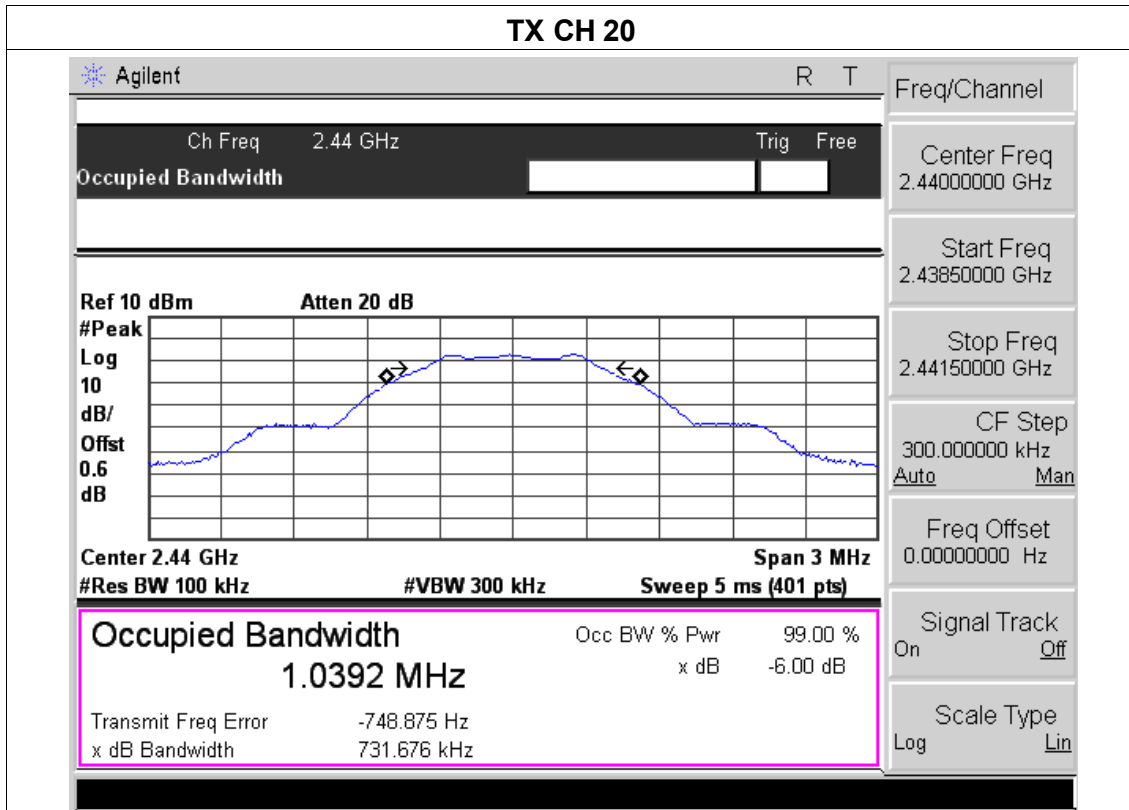

8. PEAK OUTPUT POWER TEST

8.1 APPLIED PROCEDURES / LIMIT

| FCC Part15 (15.247) , Subpart C | | | | |
|---------------------------------|-------------------|-----------------|-----------------------|--------|
| Section | Test Item | Limit | Frequency Range (MHz) | Result |
| 15.247(b)(3) | Peak Output Power | 1 watt or 30dBm | 2400-2483.5 | PASS |

8.2 TEST PROCEDURE

- a. The EUT was directly connected to the Power meter

8.3 TEST SETUP



8.4 EUT OPERATION CONDITIONS

The EUT tested system was configured as the statements of 2.3 Unless otherwise a special operating condition is specified in the follows during the testing.



8.5 TEST RESULTS

| | | | |
|---------------|---------------------------|---------------------|---------|
| EUT : | T Touch | Model Name : | HB-04 |
| Temperature : | 25 °C | Relative Humidity : | 60% |
| Pressure : | 1012 hPa | Test Voltage : | DC 3.7V |
| Test Mode : | TX Mode /CH01, CH20, CH40 | | |

| TX Mode | | | |
|-------------|-----------------|-----------------------------------|-----------|
| Test Channe | Frequency (MHz) | Peak Conducted Output Power (dBm) | LIMIT dBm |
| CH01 | 2402 | -7.625 | 30 |
| CH20 | 2440 | -7.333 | 30 |
| CH40 | 2480 | -7.158 | 30 |

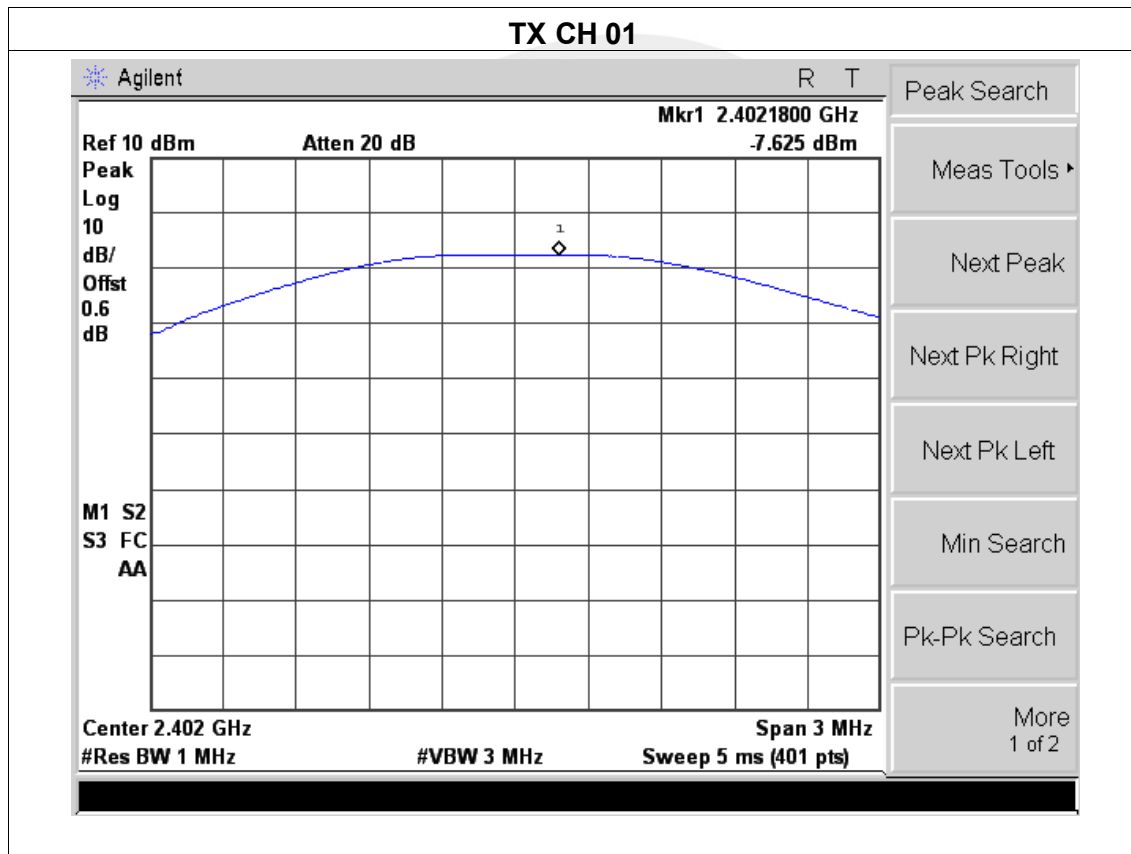

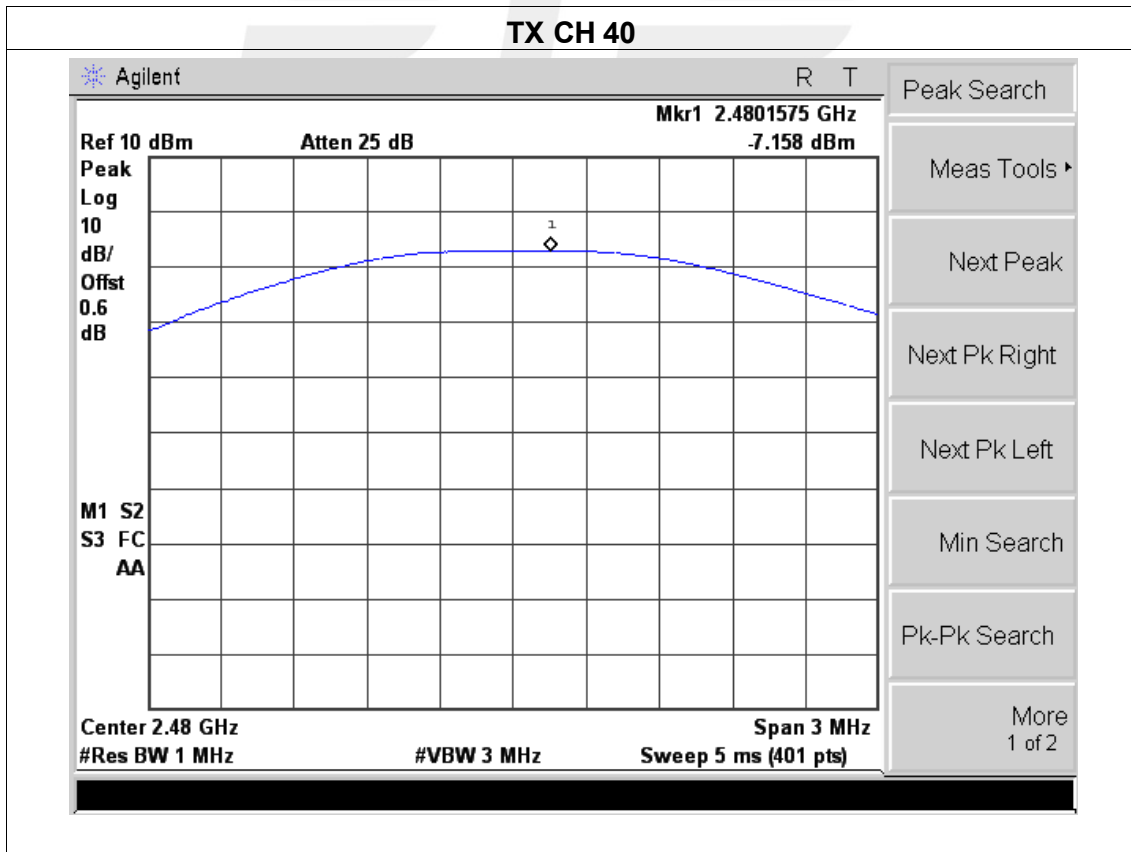
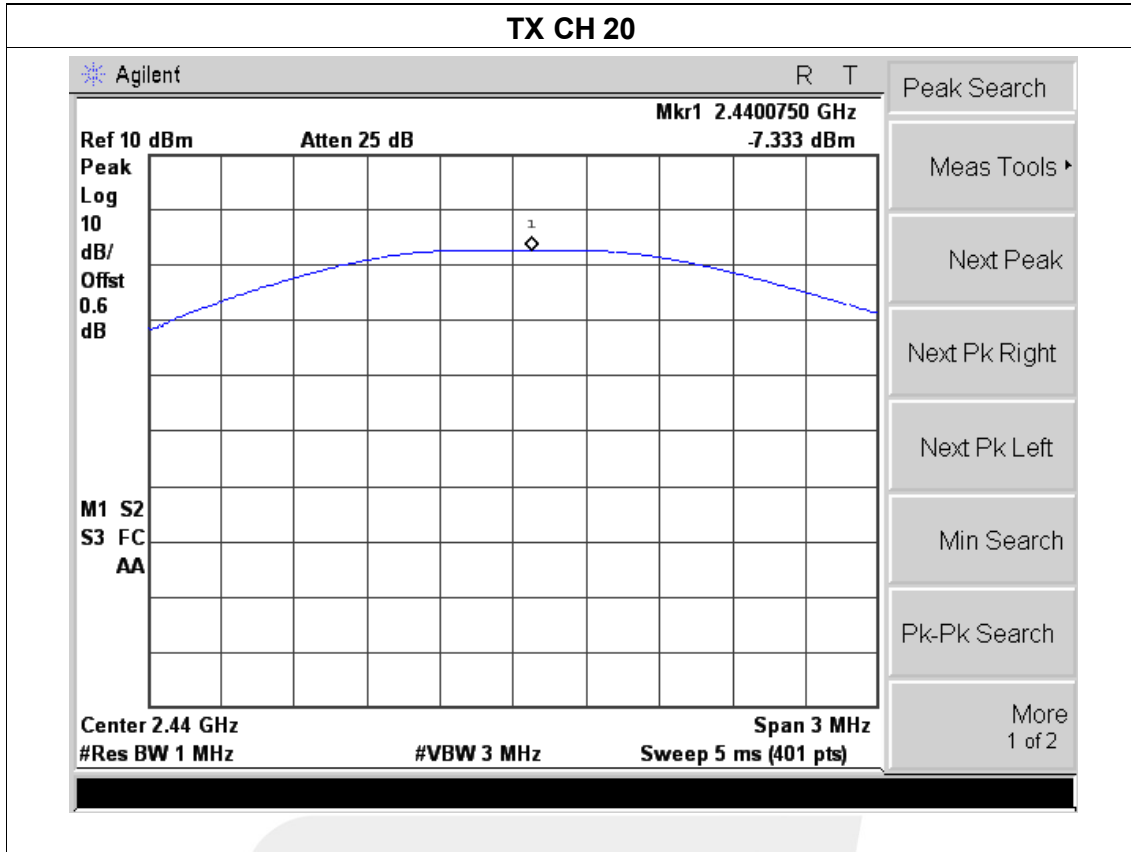



9. ANTENNA REQUIREMENT

9.1 STANDARD REQUIREMENT

15.203 requirement: For intentional device, according to 15.203: an intentional radiator shall be designed to ensure that no antenna other than that furnished by the responsible party shall be used with the device.

9.2 EUT ANTENNA

The EUT antenna is ceramic Antenna. It comply with the standard requirement.



10. EUT TEST PHOTO

Radiated Measurement Photos

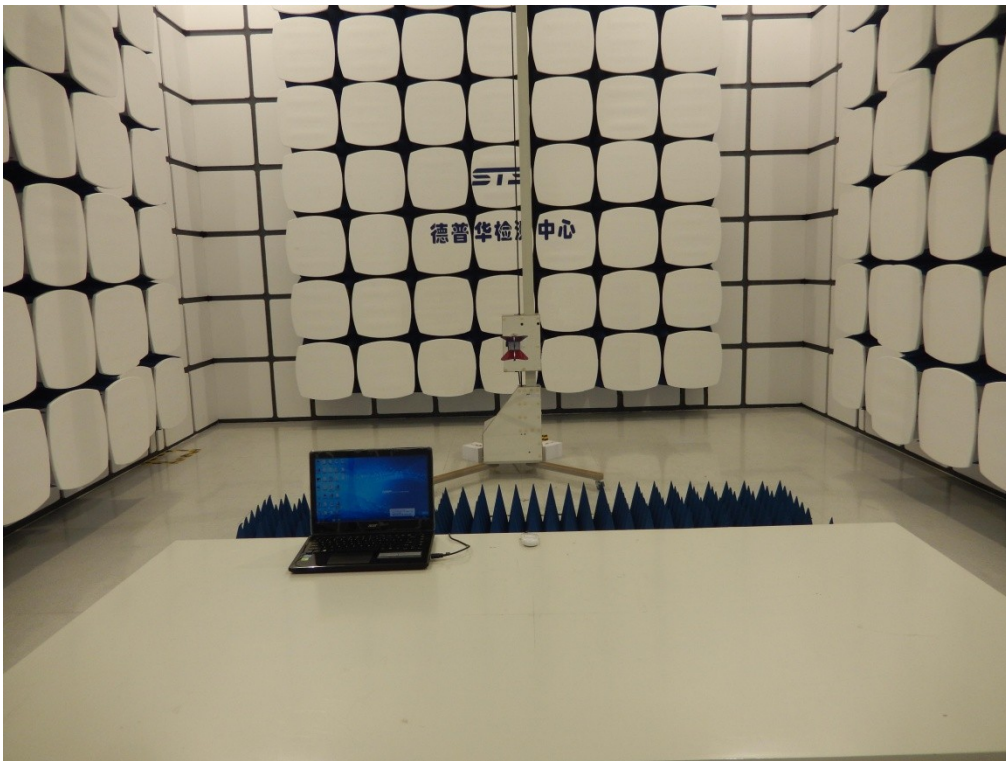
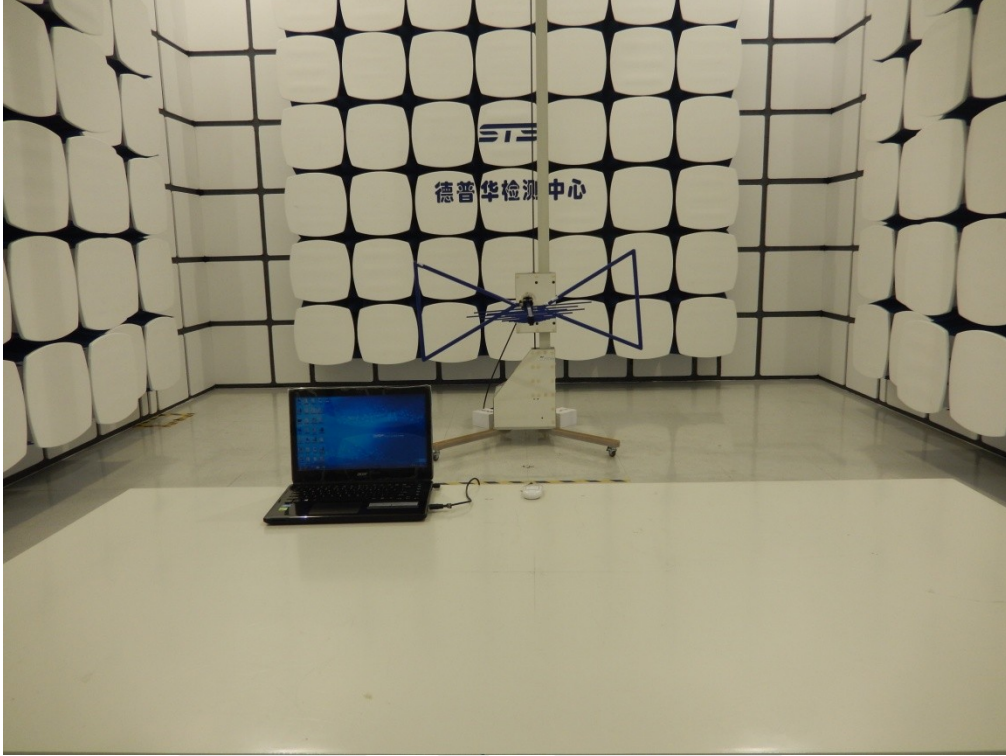

Conducted Measurement Photos

