



# INDOOR PET CONTROL

Répulsif à spray d'intérieur

**Transmitter Model : PFBORRER002**

**Receiver Model : PFBORRER001**



**“FCC” DECLARATION OF CONFORMITY**

**FCC rules – PART 15**

**NUM'AXES**

**declares that**

**the equipment below:**

**EYENIMAL Outdoor Bark Control**

**complies to all dispositions of the part 15 of the FCC rules**

**This device complies with part 15 of the FCC. Operation is subject to the following conditions: (1) this device may not cause harmful interference, and (2) this device must accept any interference received including interferences that may cause undesired operation.**

---

**DECLARATION « CE » DE CONFORMITE  
« EC » DECLARATION OF CONFORMITY  
NUM'AXES**

**déclare que / declares that  
le répulsif à spray / the spray repellent**

**EYENIMAL Indoor Pet Control**

**satisfait à toutes les dispositions de la Directive N° 2004/108/CE du Conseil Européen  
complies to all disposition of the European Council Directive Below N° 2004/108/CE**



---

**EYENIMAL®** est une marque déposée par la société Num'Axes S.A à Directoire et Conseil de Surveillance – France

**EYENIMAL®** is a trademark of Num'Axes S.A company – France

**NUM'AXES**

745 rue de la Bergeresse  
ZAC des Aulnaies  
BP 30157 - 45161 Olivet Cedex  
FRANCE  
Tél. +33 (0)2 38 63 64 40  
Fax +33 (0)2 38 63 31 00

# User's guide

## TECHNICAL FEATURES

### The packaging includes:

- a transmitter collar equipped with a CR2032 Lithium battery.
- a repulsive base.
- an odourless spray refill (150 sprays).
- a user's guide.

### Product details:

Transmitter collar equipped with a CR2032 Lithium battery

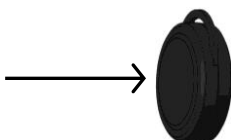

### Technical features of the base:

|                         |   |
|-------------------------|---|
| Power supply            | 4 LR14 1.5V type C alkaline batteries (not supplied)                      |
| Battery life            | Up to 72 days   |
| On/Off indicator        | Green flashing every 8 second   |
| Battery level indicator | Red flashing every 3 second   |
| Working modes           | mode 1: spray only<br>mode 2: beep tone only<br>mode 3: beep tone + spray |
| Detection range         | from 30cm to 60cm   |
| Dimensions              | 19cm x 12,5cm x 12,5cm  |
| Weight (with batteries) | 730g  |
| Use temperature         | Between - 20°C and + 45°C   |

**Technical features of the transmitter collar:**

|                           |   |
|---------------------------|---|
| Power supply              | 1 3V, CR2032 Lithium battery (battery supplied) |
| Battery life              | 70 days   |
| Dimensions                | 28,5mm x 11,5mm                                 |
| Weight (with the battery) | 8g  |

**Information:**

In compliance with the EC regulation n° 1272/2008 and with the directives 67/548/CEE, 1999/45/CE, the 134A HFA gas which plays the role of propeller for the EYENIMAL odourless spray refills has no physical danger, neither danger for health or for the environment.

Hereby, NUMAXES, declares that this (Indoor pet control) is in compliance with the essential requirements and other relevant provisions of Directive 1999/5/EC.

Caution: risk of explosion if battery is replaced by an incorrect type. Dispose of used batteries according to the instructions.

**USE**

**BEFORE USING YOUR DEVICE, READ CAREFULLY THE EXPLANATIONS OF THIS GUIDE. WE RECOMMEND YOU TO KEEP THIS GUIDE FOR ANY FURTHER REFERENCE.**

**How to insert and remove the batteries of the base:**

The repulsive base is designed to work with 4 LR14 1.5V type C alkaline batteries (not supplied).

- Turn the bedplate of the base to the right to open it
- Remove the battery cover then insert the batteries by paying attention to the polarity

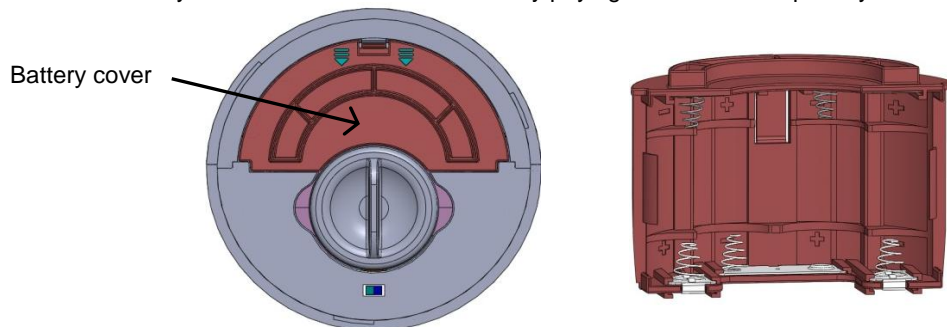

- Put the battery cover back then close the bedplate by turning it to the left

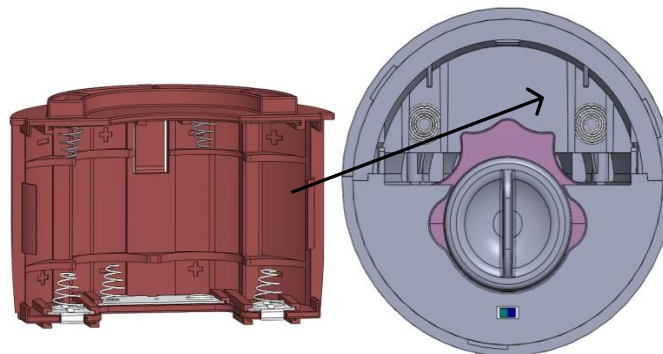
**How to insert and remove the spray refill:**

**WARNING:** the repulsive base works only with the EYENIMAL odourless spray refill.

- Turn the bedplate of the base to the right to open it
- Unscrew by hand the cap of the spray refill housing then insert the spray refill

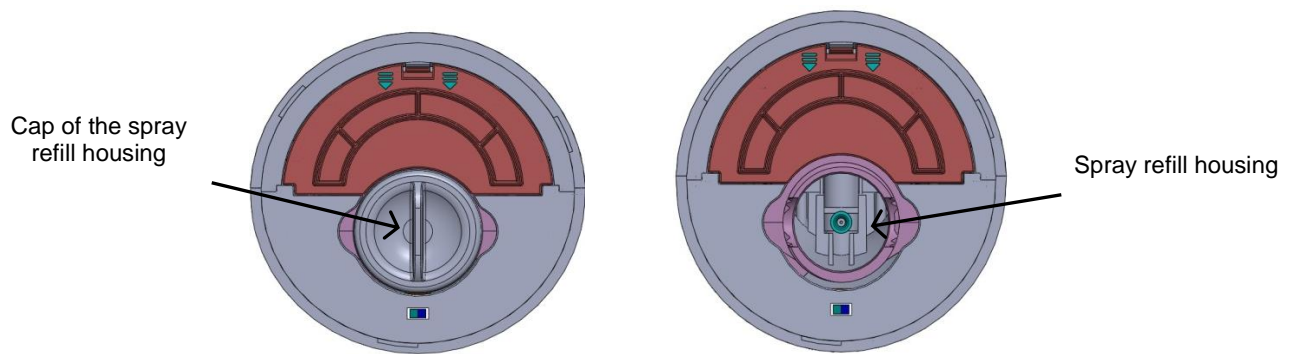

- Screw by hand the cap of the spray refill housing then close the bedplate by turning it to the left

#### How to turn on/off the base:

- Press the On/Off button
- 1 beep tone confirms it is on
- The base light indicator lights on continuously for 3 seconds then flashes every 8 second: the base is on

#### How to insert and remove the battery of the transmitter collar:

The transmitter collar is designed to work with a 3V, CR2032 Lithium battery (included).

- Loosen by hand the collar by following the arrow's way, then insert the battery in its housing by paying attention to the polarity.
- Close the collar



#### Deactivate the transmitter collar:

To deactivate the transmitter collar you have to remove the battery from its housing.

**To increase the battery life of the transmitter collar, we recommend you to deactivate the unit if you are not using it for a long period.**

#### Functioning:

When the pet wearing the collar enters in the detection zone, the base emits up to 3 beep tones and/or 3 sprays each 5 second.

After 3 warnings, if the pet stays in the detection zone, the base goes into safety mode.

The pet has to go out of the detection zone so that the base goes off again.

#### How to change the working mode:

To change the working mode of the base, you have to open the bedplate of the base and put the button of mode selection on the mode you want.

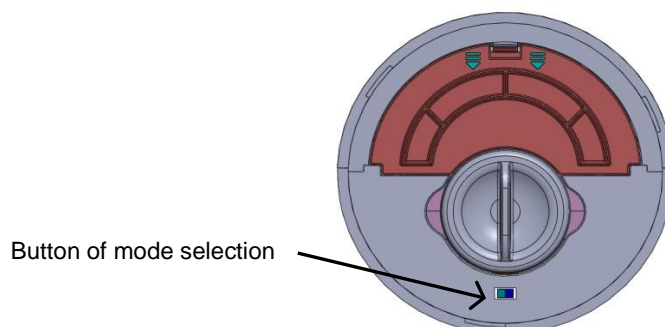

- Position 1: spray only

- Position 2: beep tone only
- Position 3: beep tone + spray

**Advice:** we recommend you at the beginning of your teaching process to use the position 3. Then, as the pet has understood that the zone is forbidden, you can go into the position 2. The position 1 is to be used if you want to make less noise (in the night, for instance).

**Cautions for use:**

- This device is only reserved for a use with cats and dogs. Do not try to use it for any other purpose than the one described in this user's guide.
- This device is not a toy.
- Children should be supervised to ensure that they do not play with the device.
- This device must not be used by people under 14.

**Maintenance:**

- Remove the batteries before cleaning the device.
- Avoid to use volatile products such as solvents to clean the device.
- Simply use a soft cloth, lightly moistened with water or neutral detergent.
- Do not immerse the device into the water or any other liquid.

Should your product develop a fault, first read this guide carefully again and **make sure the problem is not caused by a low battery or a wrong use.**

**WARRANTY**

**A. Troubleshooting**

Should your product stop working or develop a fault, first read this user's guide over, then check the batteries and replace them if necessary and retry. Then make sure the problem is not caused by an empty reservoir. Also check that you are using the product correctly.

If the problem persists, contact your distributor or check out on [www.numaxes.com](http://www.numaxes.com). You can also contact NUM'AXES at **+33.2.38.69.96.27** or by Email [export@numaxes.com](mailto:export@numaxes.com).

Depending on the extent of the malfunction, you may have to return your product for service and repair.

For all repairs, please supply the following:

- the complete product
- the proof of purchase (invoice or sales receipt)

If you omit one of these items, the After Sales Service will have to invoice you for any repair costs incurred.

**B. Warranty**

NUM'AXES guarantees the products against all manufacturing defects for two years after purchase. All postage and packing charges will be the purchaser's sole responsibility.

**C. Warranty conditions**

1. The warranty will be effective only with a proof of purchase (invoice or sales receipt).  
The warranty is exclusive to the original purchaser.
2. This warranty does not cover the following:
  - changing the battery,
  - direct or indirect problems incurred when sending the product back to the distributor or to NUM'AXES,
  - damage to the product caused by:
    - negligence or incorrect use (ex: bites, breakage, cracking),
    - misuse from not following directions
    - repairs performed by unauthorized persons.
  - loss or theft.
3. If the product is found to be defective, NUM'AXES will either decide to repair or to replace it.
4. No claim may be made against NUM'AXES, particularly in relation to incorrect use or breakdown.
5. NUM'AXES reserves the right to modify the characteristics of its products with a view to making technical improvements or to complying with new regulations.
6. The information contained in this guide may be subject to amendment without prior notice.
7. Photos and drawings are not contractual.

**D. Register your product**

Your product can be registered on our website at [www.evenimal.com](http://www.evenimal.com).

**E. Spare parts**

You can purchase spare parts from your supplier at any time (batteries, odourless refills).

**F. Disposing or recycling of your device at the end of its life**

The pictogram  which appears on your product means that this one can not be thrown with household refuse.

You have to bring the device to a collection location suitable for treatment, development, recycling of electronic wastes or bring it back to your distributor.

Adopting this process, you do something for the environment; you contribute to the preservation of natural resources and to the protection of human health.

This equipment has been tested and found to comply with the limits for a Class B digital device, pursuant to part 15 of the FCC Rules. These limits are designed to provide reasonable protection against harmful interference in a residential installation. This equipment generates, uses and can radiate radio frequency energy and, if not installed and used in accordance with the instructions, may cause harmful interference to radio communications. However, there is no guarantee that interference will not occur in a particular installation. If this equipment does cause harmful interference to radio or television reception, which can be determined by turning the equipment off and on, the user is encouraged to try to correct the interference by one or more of the following measures:

- Reorient or relocate the receiving antenna.
- Increase the separation between the equipment and receiver.
- Connect the equipment into an outlet on a circuit different from that to which the receiver is connected.
- Consult the dealer or an experienced radio/TV technician for help.

Caution: Any changes or modifications to this device not explicitly approved by manufacturer could void your authority to operate this equipment.

This device complies with part 15 of the FCC Rules. Operation is subject to the following two conditions: (1) This device may not cause harmful interference, and (2) this device must accept any interference received, including interference that may cause undesired operation.



# EYENIMAL

A LIVING ADVENTURE

contact@eyenimal.com  
www.eyenimal.com