



# FCC TEST REPORT

According to

## FCC Rules and Regulations Part 15 Subpart C

Applicant : Hillstone Networks Corp.  
Address : 292 Gibraltar Drive, Suite 105 Sunnyvale, CA  
94089  
Equipment : Firewall Appliance  
Model No. : SG-6000-E1100WG3w  
Trade Name : **Hillstone**  
NETWORKS  
FCC ID : 2AD6IE1100WG3W

- The test result refers exclusively to the test presented test model / sample.
- Without written approval of **CerpPASS Technology (Suzhou) Co., Ltd.** the test report shall not be reproduced except in full.
- This test report is only applicable to European Community.

The test report must not be used by the clients to claim product certification approval by **NVLAP** or any agency of the Government.



## Contents

<b>1. Report of Measurements and Examinations</b>	<b>6</b>
1.1 List of Measurements and Examinations	6
<b>2. Test Configuration of Equipment under Test</b>	<b>7</b>
2.1 Feature of Equipment under Test	7
2.2 Carrier Frequency of Channels	7
2.3 Test Mode and Test Software	8
2.4 Description of Test System	9
2.5 General Information of Test	10
2.6 Measurement Uncertainty	10
<b>3. Test Equipment and Ancillaries Used for Tests</b>	<b>11</b>
<b>4. Antenna Requirements</b>	<b>12</b>
4.1 Standard Applicable	12
4.2 Antenna Construction and Directional Gain	12
<b>5. Test of Conducted Emission</b>	<b>13</b>
5.1 Test Limit	13
5.2 Test Procedures	13
5.3 Typical Test Setup	14
5.4 Test Result and Data	15
<b>6. Test of Radiated Emission</b>	<b>17</b>
6.1 Test Limit	17
6.2 Test Procedures	17
6.3 Typical Test Setup	18
6.4 Test Result and Data	19
<b>7. 6dB Bandwidth Measurement Data</b>	<b>31</b>
7.1 Test Limit	31
7.2 Test Procedures	31
7.3 Test Setup Layout	31
7.4 Test Result and Data	32
<b>8. Maximum Peak Output Power</b>	<b>60</b>
8.1 Test Limit	60
8.2 Test Procedures	60
8.3 Test Setup Layout	60
8.4 Test Result and Data	61
<b>9. Power Spectral Density</b>	<b>65</b>
9.1 Test Limit	65
9.2 Test Procedures	65
9.3 Test Setup Layout	65
9.4 Test Result and Data	66
<b>10. Band Edges Measurement</b>	<b>74</b>
10.1 Test Limit	74
10.2 Test Procedure	74
10.3 Test Setup Layout	74
10.4 Test Result and Data	75



10.5	Restrict Band Emission Measurement Data .....	81
<b>11.</b>	<b>Restricted Bands of Operation .....</b>	<b>83</b>
11.1	Labeling Requirement .....	83





# CERTIFICATE OF COMPLIANCE

According to

## FCC Rules and Regulations Part 15 Subpart C

Applicant : Hillstone Networks Corp.  
Address : 292 Gibraltar Drive, Suite 105 Sunnyvale, CA 94089  
Equipment : Firewall Appliance  
Model No. : SG-6000-E1100WG3w  
FCC ID : 2ADNVE1100WG3W

I HEREBY CERTIFY THAT :

The measurements shown in this test report were made in accordance with the procedures given in ANSI C63.4 2009. The equipment was passed the test performed according to FCC Rules and Regulations Part 15 Subpart C §15.247, KDB558074 and KDB662911.

This EUT has been also tested and compiled with the requirement of FCC Part 15, Subpart B, recorded in a separate test report.

The testing was carried out on Nov.21~Dec.10,2014 at CerpPASS Technology (Suzhou) Co., Ltd.

Approved by:

Miro Chueh  
Technical director



# 1. Report of Measurements and Examinations

## 1.1 List of Measurements and Examinations

FCC Rule	Description of Test	Result
15.203	Antenna Requirement	Pass
15.207	Conducted Emission	Pass
15.209 15.247(d)	Radiated Emission	Pass
15.247(a)(2)	6dB Bandwidth	Pass
15.247(b)	Maximum Peak Output Power	Pass
15.247(d)	100kHz Bandwidth of Frequency Band Edges	Pass
15.247(e)	Power Spectral Density	Pass
1.1307 1.1310 2.1091 2.1093	RF Exposure Compliance	Pass



## 2. Test Configuration of Equipment under Test

### 2.1 Feature of Equipment under Test

<b>Modulation Type</b>	DSSS, OFDM
<b>Frequency Range</b>	2412-2462MHz, 5725-5825MHz
<b>Channel Number</b>	802.11b/g/n HT20: 11 channels 802.11n HT40: 7 channels 802.11a/ n HT20: 5 channels 802.11n HT40: 2 channels
<b>Channel Spacing</b>	802.11b/g:5MHz 802.11n:20MHz
<b>Antenna Type/ gain</b>	Dipole Antenna with 3.0dBi
<b>Power Source</b>	DELTA ELECTRONICS INC. MODEL:ADP-36LH B I/P: 100-240V~1.2A 50-60Hz O/P: 12V---3A

Note: For a more detailed features description, please refer to the manufacturer's specifications or the User's Manual.

### 2.2 Carrier Frequency of Channels

802.11b, 802.11g, 802.11n HT-20 (2412MHz~2462MHz)

Channel	Frequency(MHz)	Channel	Frequency(MHz)
<b>*01</b>	<b>2412</b>	07	2442
02	2417	08	2447
03	2422	09	2452
04	2427	10	2457
05	2432	<b>*11</b>	<b>2462</b>
<b>*06</b>	<b>2437</b>	---	---

802.11n HT-40(2422-2452MHz)

Channel	Frequency(MHz)	Channel	Frequency(MHz)
---	---	07	2442
---	---	08	2447
<b>*03</b>	<b>2422</b>	<b>*09</b>	<b>2452</b>
04	2427	---	---
05	2432	---	---
<b>*06</b>	<b>2437</b>	---	---

802.11a, 802.11n HT-20 (5745MHz~5825MHz)

Channel	Frequency(MHz)	Channel	Frequency(MHz)
<b>*149</b>	<b>5745</b>	161	5805
153	5765	<b>*165</b>	<b>5825</b>
<b>*157</b>	<b>5785</b>	---	---

802.11a, 802.11n HT-40 (5745MHz~5825MHz)

Channel	Frequency(MHz)	Channel	Frequency(MHz)
<b>*151</b>	<b>5755</b>	<b>*159</b>	<b>5795</b>

Note: Channels remarked \* are selected to perform test.



### 2.3 Test Mode and Test Software

- a. During testing, the interface cables and equipment positions were varied according to ANSI C63.4.
- b. The complete test system included Notebook and EUT for RF test.
- c. The following test modes were performed for test:
  - 802.11b/g/n HT-20: CH01: 2412MHz, CH06: 2437MHz, CH11: 2462MHz
  - 802.11n HT-40: CH03: 2422MHz, CH06: 2437MHz, CH09: 2452MHz
  - 802.11a/ n HT-20: CH149: 5745MHz, CH157: 5785MHz, CH165: 5825MHz
  - 802.11n HT-40: CH151: 5755MHz, CH159: 5795MHz





### 2.4 Description of Test System

No	Device	Manufacturer	Model No.	Description
1	PC	HP	HP Compaq Elite 8200 MTPC	Non-Shielded ,1.8m
2	USB Keyboard	DELL	SK-8115	N/A
3	USB Mouse	DELL	B889	N/A
4	Modem	Kingnet	KN-JT560	N/A
5	Printer	LENOVO	4126-LV7	N/A
6	LCD Monitor	DELL	SE198WFp	Non-Shielded ,1.8m (R43346)
7	Notebook	SONY	PCG-71811P	Non-Shielded ,1.5m (R33021)
8	USB DISK	SANDISK	N/A	N/A



## 2.5 General Information of Test

Test Site:	CERPASS TECHNOLOGY (SUZHOU) CO., LTD.
Performand Location :	No.66,Tangzhuang Road, Suzhou Industrial Park, Jiangsu 215006, China
NVLAP LAB Code :	200814-0
FCC Registration Number :	916572, 331395
IC Registration Number :	7290A-1, 7290A-2
VCCI Registration Number :	T-343 for Telecommunication Test C-2919 for Conducted emission test R-2670 for Radiated emission test below 1GHz G-227 for Radiated emission test above 1GHz

## 2.6 Measurement Uncertainty

Measurement Item	Measurement Frequency	Polarization	Uncertainty
Conducted Emission	9 kHz ~ 30 MHz	LINE/NEUTRAL	±2.71 dB
Radiated Emission	30 MHz ~ 25GHz	Vertical	±4.11 dB
		Horizontal	±4.10 dB
Occupied Bandwidth	---	---	±7500 Hz
Maximum Peak Output Power	---	---	±1.4 dB
Band Edges	---	---	±2.2 dB
Power Spectral Density	---	---	±2.2 dB



### 3. Test Equipment and Ancillaries Used for Tests

Instrument/Ancillary	Manufacturer	Model No.	Serial No.	Calibration Date	Valid Date.
Test Receiver	R&S	ESCI	100565	2014.03.24	2015.03.23
AMN	R&S	ESH2-Z5	100182	2014.09.11	2015.09.10
ISN	FCC	FCC-TLISN-T2-02	20379	2014.03.24	2015.03.23
ISN	FCC	FCC-TLISN-T4-02	20380	2014.03.24	2015.03.23
ISN	FCC	FCC-TLISN-T8-02	20381	2014.03.24	2015.03.23
ISN	TESEQ	ISN ST08	30175	2014.03.24	2015.03.23
Current Probe	R&S	EZ-17	100303	2014.04.04	2015.04.03
Passive Voltage Probe	R&S	ESH2-Z3	100026	2014.03.24	2015.03.23
Pulse Limiter	R&S	ESH3-Z2	100529	2014.03.24	2015.03.23
Temperature/ Humidity Meter	Zhicheng	ZC1-11	CEP-TH-004	2014.03.31	2015.03.30
EMI Test Receiver	R&S	ESCI	100563	2014.02.10	2015.02.09
H64 Preampifier	HP	8447F	3113A05582	2014.03.24	2015.03.23
Preampifier	Agilent	8449B	3008A02342	2014.03.24	2015.03.23
Ultra Broadband Antenna	R&S	HL562	100362	2014.05.24	2015.05.23
Broad-Band Horn Antenna	Schwarzbeck	BBHA9120D	9120D-619	2014.05.24	2015.05.23
Broad-Band Horn Antenna	Schwarzbeck	BBHA9170	9170-348	2014.11.04	2015.11.03
Spectrum Analyzer	R&S	FSP40	100324	2014.03.23	2015.03.24
Spectrum Analyzer	Agilent	N9010A	MY51350515	2013.09.29	2014.09.28



## 4. Antenna Requirements

### 4.1 Standard Applicable

For intentional device, according to FCC 47 CFR Section 15.203, an intentional radiator shall be designed to ensure that no antenna other than that furnished by the responsible party shall be used with the device.

And according to FCC 47 CFR Section 15.247 (b), if transmitting antennas of directional gain greater than 6dBi are used, the power shall be reduced by the amount in dB that the directional gain of the antenna exceeds 6dBi.

### 4.2 Antenna Construction and Directional Gain

WIFI

Antenna Type: Dipole Antenna

Antenna Gain: 3.0 dBi at 2.4GHz~2.5GHz and 4.9GHz~5.8GHz



## 5. Test of Conducted Emission

### 5.1 Test Limit

Conducted Emissions were measured from 150 kHz to 30 MHz with a bandwidth of 9 KHz on the 120 VAC power and return leads of the EUT according to the methods defined in ANSI C63.4-2009 Section 3.1. The EUT was placed on a nonmetallic stand in a shielded room 0.8 meters above the ground plane as shown in section 2.2. The interface cables and equipment positioning were varied within limits of reasonable applications to determine the position produced maximum conducted emissions.

Frequency (MHz)	Quasi Peak (dB $\mu$ V)	Average (dB $\mu$ V)
0.15 – 0.5	66-56*	56-46*
0.5 – 5.0	56	46
5.0 – 30.0	60	50

\*Decreases with the logarithm of the frequency.

### 5.2 Test Procedures

- a. The EUT was placed 0.4 meter from the conducting wall of the shielding room was kept at least 80 centimeters from any other grounded conducting surface.
- b. Connect EUT to the power mains through a line impedance stabilization network (LISN).
- c. All the support units are connecting to the other LISN.
- d. The LISN provides 50 ohm coupling impedance for the measuring instrument.
- e. The FCC states that a 50 ohm, 50 micro-Henry LISN should be used.
- f. Both sides of AC line were checked for maximum conducted interference.
- g. The frequency range from 150 kHz to 30 MHz was searched.
- h. Set the test-receiver system to Peak Detect Function and Specified Bandwidth with Maximum Hold Mode.



### 5.3 Typical Test Setup

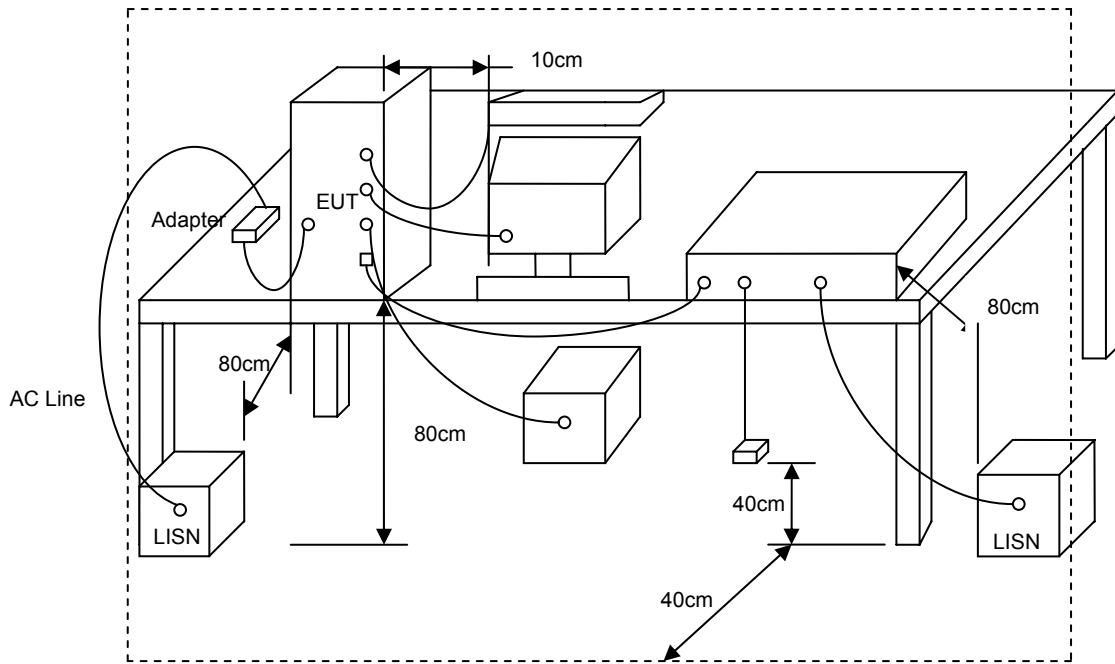



5.4 Test Result and Data

Test Mode 1:	Full load with broadcast storm (SG-6000-E1100WG3w) for 110V		
AC Power :	AC 120V/60Hz	Phase :	LINE
Temperature :	22°C	Humidity :	50%
Pressure(mbar) :	1002	Date:	2014/12/08

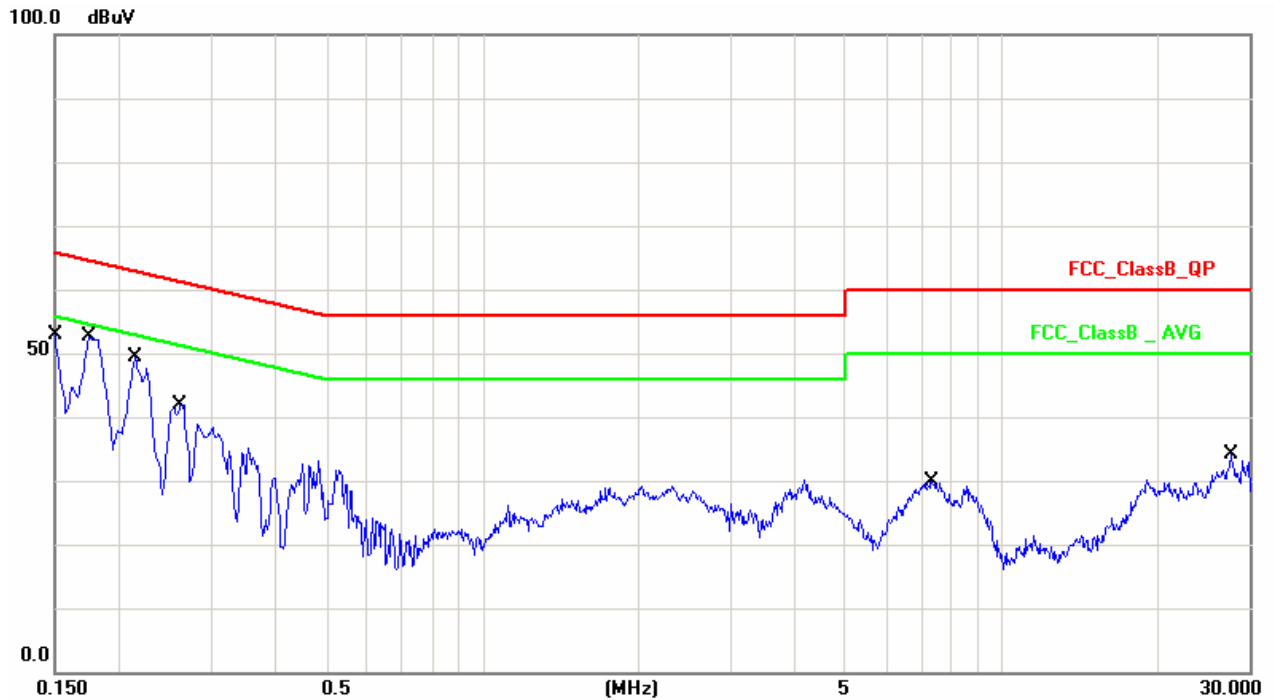

No.	Frequency (MHz)	Factor (dB)	Reading (dBuV)	Level (dBuV)	Limit (dBuV)	Margin (dB)	Detector
1	0.1500	10.13	26.94	37.07	65.99	-28.92	QP
2	0.1500	10.13	5.58	15.71	55.99	-40.28	AVG
3	0.1740	10.13	42.19	52.32	64.76	-12.44	QP
4	0.1740	10.13	28.29	38.42	54.76	-16.34	AVG
5	0.2140	10.12	35.61	45.73	63.04	-17.31	QP
6	0.2140	10.12	19.36	29.48	53.04	-23.56	AVG
7	0.2620	10.13	29.90	40.03	61.36	-21.33	QP
8	0.2620	10.13	14.61	24.74	51.36	-26.62	AVG
9	7.3540	10.26	16.56	26.82	60.00	-33.18	QP
10	7.3540	10.26	9.40	19.66	50.00	-30.34	AVG
11	27.6620	10.44	16.24	26.68	60.00	-33.32	QP
12	27.6620	10.44	10.31	20.75	50.00	-29.25	AVG

Note: Measurement Level = Reading Level + Correct Factor+ Attenuator



Test Mode 1:	Full load with broadcast storm (SG-6000-E1100WG3w) for 110V		
AC Power :	AC 120V/60Hz	Phase :	NEUTRAL
Temperature :	22°C	Humidity :	50%
Pressure(mbar) :	1002	Date:	2014/12/08

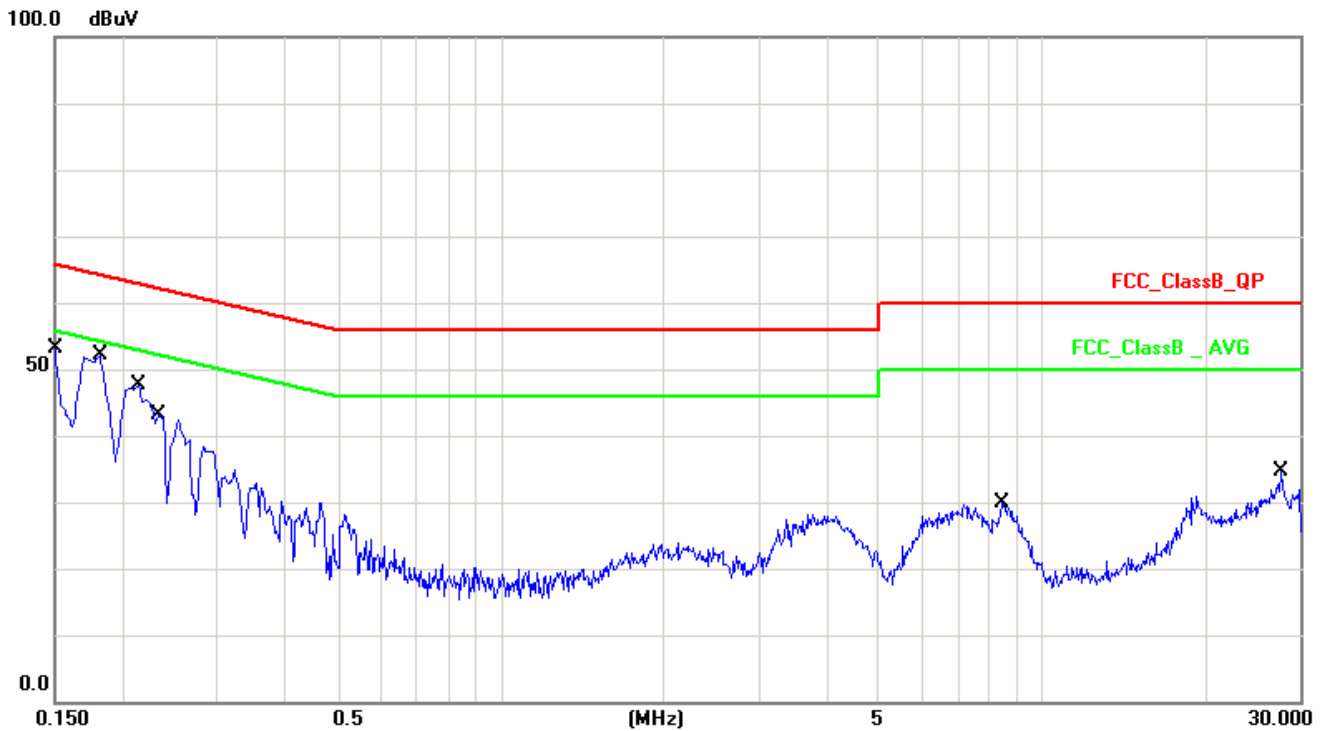

No.	Frequency (MHz)	Factor (dB)	Reading (dBuV)	Level (dBuV)	Limit (dBuV)	Margin (dB)	Detector
1	0.1500	10.13	41.59	51.72	65.99	-14.27	QP
2	0.1500	10.13	23.69	33.82	55.99	-22.17	AVG
3	0.1819	10.12	39.83	49.95	64.39	-14.44	QP
4	0.1819	10.12	24.57	34.69	54.39	-19.70	AVG
5	0.2140	10.12	34.90	45.02	63.04	-18.02	QP
6	0.2140	10.12	18.60	28.72	53.04	-24.32	AVG
7	0.2340	10.12	22.06	32.18	62.30	-30.12	QP
8	0.2340	10.12	0.63	10.75	52.30	-41.55	AVG
9	8.4700	10.26	14.21	24.47	60.00	-35.53	QP
10	8.4700	10.26	7.77	18.03	50.00	-31.97	AVG
11	27.8260	10.44	17.04	27.48	60.00	-32.52	QP
12	27.8260	10.44	10.55	20.99	50.00	-29.01	AVG

Note: Measurement Level = Reading Level + Correct Factor+ Attenuator

Test engineer: Moses





## 6. Test of Radiated Emission

### 6.1 Test Limit

In any 100kHz bandwidth outside the frequency band in which the spread spectrum or digitally modulated intentional radiator is operating, the radio frequency power that is produced by the intentional radiator shall be at least 20dB below that in the 100kHz bandwidth within the band that contains the highest level of the desired power, based on either an RF conducted or a radiated measurement. If the transmitter measurement is based on the maximum conducted output power, the attenuation required under this paragraph shall be 30dB instead of 20dB. In addition, radiated emissions which fall in section 15.205(a) the restricted bands must also comply with the radiated emission limit specified in section 15.209(a).

Frequency (MHz)	Field Strength (microvolt/meter)	Measurement Distance (meters)
0.009 ~ 0.490	2400/F(kHz)	300
0.490 ~ 1.705	24000/F(kHz)	30
1.705 ~ 30.0	30	30
30 ~ 88	100	3
88 ~ 216	150	3
216 ~ 960	200	3
Above 960	500	3

### 6.2 Test Procedures

- The EUT was placed on a rotatable table top 0.8 meter above ground.
- The EUT was set 3 meters from the interference receiving antenna which was mounted on the top of a variable height antenna tower.
- The table was rotated 360 degrees to determine the position of the highest radiation.
- The antenna is a broadband antenna and its height is varied between one meter and four meters above ground to find the maximum value of the field strength both horizontal polarization and vertical polarization of the antenna are set to make the measurement.
- For each suspected emission the EUT was arranged to its worst case and then tune the antenna tower (from 1 M to 4 M) and turn table (from 0 degree to 360 degrees) to find the maximum reading.
- Set the test-receiver system to Peak or CISPR quasi-peak Detect Function and specified bandwidth with Maximum Hold Mode.
- If the emission level of the EUT in peak mode was 3 dB lower than the limit specified, then testing will be stopped and peak values of EUT will be reported, otherwise, the emissions which do not have 3 dB margin will be repeated one by one using the quasi-peak method and reported.
- For testing above 1GHz, the emission level of the EUT in peak mode was 20dB lower than average limit (that means the emission level in peak mode also complies with the limit in average mode), then testing will be stopped and peak values of EUT will be reported, otherwise, the emissions will be measured in average mode again and reported.
- “Cone of radiation” has been considered to be 3dB bandwidth of the measurement antenna.



### 6.3 Typical Test Setup

For radiated emissions below 30MHz

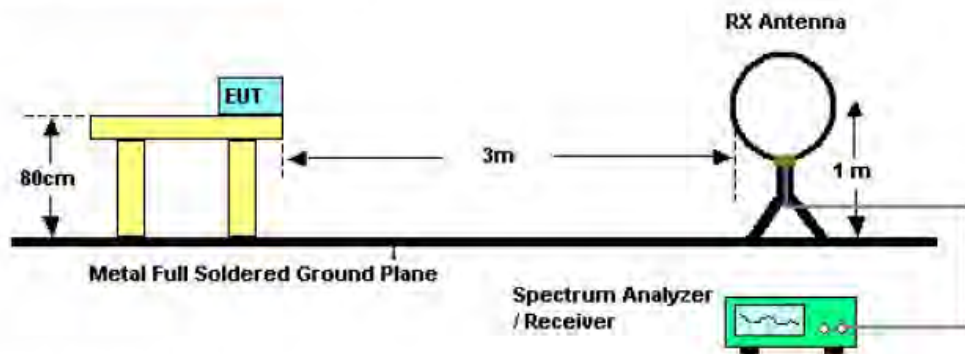

For radiated emissions above 30MHz

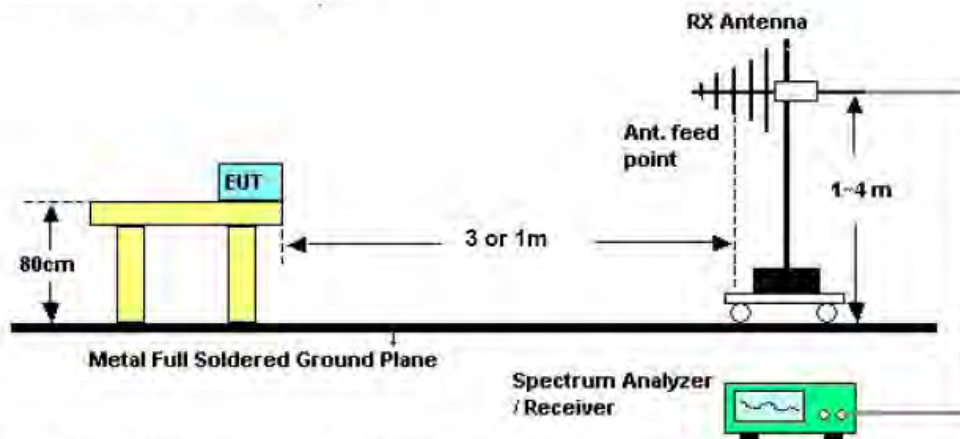

Above 10 GHz shall be extrapolated to the specified distance using an extrapolation factor of 20 dB/decade from 3m to 1m.

Distance extrapolation factor =  $20 \log(\text{specific distance [3m]} / \text{test distance [1m]})$  (dB);

Limit line = specific limits (dBuV) + distance extrapolation factor [9.54 dB].



## 6.4 Test Result and Data

### Below 30MHz

The 9kHz - 30MHz spurious emission is under limit 20dB more.



## Below 1GHz

Engineer : Amos	
Site : EMC Lab AC 102	Time : 2014-11-21
Limit : FCC_CLASS_B_03M_QP	Margin : 6
EUT : Tablet PC	Probe : VERTICAL/ HORIZONTAL
Power : AC 120V/60Hz	Note : Normal Link

Frequency (MHz)	AntPol. H/V	Correct Factor (dB)	Reading level (dBuV)	Measure Level (dBuV/m)	Limit 3m (dBuV/m)	Safe Margin (dB)	Detector mode (PK/QP)
191.0200	H	-17.97	48.49	30.52	43.50	-12.89	QP
235.6400	H	-18.57	54.27	35.70	46.00	-8.28	QP
500.4500	H	-12.38	46.59	34.21	46.00	-7.37	QP
625.5800	H	-10.19	45.13	34.94	46.00	-13.69	QP
750.7100	H	-10.03	47.12	37.09	46.00	-12.03	QP
875.8400	H	-6.86	44.93	38.07	46.00	-18.64	QP
44.5500	V	-17.03	46.98	29.95	40.00	-10.05	QP
107.5999	V	-19.04	52.59	33.55	43.50	-9.95	QP
186.1699	V	-18.36	57.46	39.10	43.50	-4.40	QP
237.5800	V	-18.30	53.52	35.22	46.00	-10.78	QP
625.5800	V	-10.52	46.63	36.11	46.00	-9.89	QP
875.8400	V	-6.85	41.16	34.31	46.00	-11.69	QP

## Note:

1. All Readings below 1GHz are Quasi-Peak, above are performed with peak and/or average measurements as necessary.
2. Measurement Level = Reading Level + Correct Factor



Above 1G:

Site : EMC Lab AC 102	Time : 2014-12-04
Limit : FCC_CLASS_B_03M_QP	Margin : 6
Test mode: Transmit by 802.11b channel 1	Probe : VERTICAL/ HORIZONTAL
Power : AC 120V/60Hz	

	Frequency (MHz)	Correct Factor (dB)	Reading Level (dBuV)	Measure Level (dBuV/m)	Margin (dB)	Limit (dBuV/m)	Detector Type	Antenna Pole (V/H)
1	4824.00	6.53	44.23	50.76	-23.24	74.00	PEAK	H
2	4824.00	6.53	38.98	45.51	-8.49	54.00	AVG	H
1	4824.00	6.53	46.52	53.05	-20.95	74.00	PEAK	V
2	4824.00	6.53	39.15	45.68	-8.32	54.00	AVG	V

Note:

1. All Readings below 1GHz are Quasi-Peak, above are performed with peak and/or average measurements as necessary.
2. Measurement Level = Reading Level + Correct Factor

Site : EMC Lab AC 102	Time : 2014-12-04
Limit : FCC_CLASS_B_03M_QP	Margin : 6
Test mode: Transmit by 802.11b channel 6	Probe : VERTICAL/ HORIZONTAL
Power : AC 120V/60Hz	

	Frequency (MHz)	Correct Factor (dB)	Reading Level (dBuV)	Measure Level (dBuV/m)	Margin (dB)	Limit (dBuV/m)	Detector Type	Antenna Pole (V/H)
1	4874.00	6.85	45.46	52.31	-21.69	74.00	PEAK	H
2	4874.00	6.85	38.57	45.42	-8.58	54.00	AVG	H
1	4874.00	6.85	46.38	53.23	-20.77	74.00	PEAK	V
2	4874.00	6.85	38.06	44.91	-9.09	54.00	AVG	V

Note:

1. All Readings below 1GHz are Quasi-Peak, above are performed with peak and/or average measurements as necessary.
2. Measurement Level = Reading Level + Correct Factor



Site : EMC Lab AC 102	Time : 2014-12-04
Limit : FCC_CLASS_B_03M_QP	Margin : 6
Test mode: Transmit by 802.11b channel 11	Probe : VERTICAL/ HORIZONTAL
Power : AC 120V/60Hz	

	Frequency (MHz)	Correct Factor (dB)	Reading Level (dBuV)	Measure Level (dBuV/m)	Margin (dB)	Limit (dBuV/m)	Detector Type	Antenna Pole (V/H)
1	4924.00	6.99	45.68	52.67	-21.33	74.00	PEAK	H
2	4924.00	6.99	38.74	45.73	-8.27	54.00	AVG	H
1	4924.00	6.99	45.39	52.38	-21.62	74.00	PEAK	V
2	4924.00	6.99	38.67	45.66	-8.34	54.00	AVG	V

Note:

1. All Readings below 1GHz are Quasi-Peak, above are performed with peak and/or average measurements as necessary.
2. Measurement Level = Reading Level + Correct Factor

Site : EMC Lab AC 102	Time : 2014-12-04
Limit : FCC_CLASS_B_03M_QP	Margin : 6
Test mode: Transmit by 802.11g channel 1	Probe : VERTICAL/ HORIZONTAL
Power : AC 120V/60Hz	

	Frequency (MHz)	Correct Factor (dB)	Reading Level (dBuV)	Measure Level (dBuV/m)	Margin (dB)	Limit (dBuV/m)	Detector Type	Antenna Pole (V/H)
1	4824.00	6.53	41.97	48.50	-25.50	74.00	PEAK	H
2	4824.00	6.53	31.08	37.61	-16.39	54.00	AVG	H
1	4824.00	6.53	43.85	50.38	-23.62	74.00	PEAK	V
2	4824.00	6.53	30.26	36.79	-17.21	54.00	AVG	V

Note:

1. All Readings below 1GHz are Quasi-Peak, above are performed with peak and/or average measurements as necessary.
2. Measurement Level = Reading Level + Correct Factor



Site : EMC Lab AC 102	Time : 2014-12-04
Limit : FCC_CLASS_B_03M_QP	Margin : 6
Test mode: Transmit by 802.11g channel 6	Probe : VERTICAL/ HORIZONTAL
Power : AC 120V/60Hz	

	Frequency (MHz)	Correct Factor (dB)	Reading Level (dBuV)	Measure Level (dBuV/m)	Margin (dB)	Limit (dBuV/m)	Detector Type	Antenna Pole (V/H)
1	4874.00	6.85	40.26	47.11	-26.89	74.00	PEAK	H
2	4874.00	6.85	29.78	36.63	-17.37	54.00	AVG	H
1	4874.00	6.85	42.18	49.03	-24.97	74.00	PEAK	V
2	4874.00	6.85	30.05	36.90	-17.10	54.00	AVG	V

Note:

1. All Readings below 1GHz are Quasi-Peak, above are performed with peak and/or average measurements as necessary.
2. Measurement Level = Reading Level + Correct Factor

Limit : FCC_CLASS_B_03M_QP	Margin : 6
Test mode: Transmit by 802.11g channel 11	Probe : VERTICAL/ HORIZONTAL
Power : AC 120V/60Hz	

	Frequency (MHz)	Correct Factor (dB)	Reading Level (dBuV)	Measure Level (dBuV/m)	Margin (dB)	Limit (dBuV/m)	Detector Type	Antenna Pole (V/H)
1	4924.00	6.99	42.35	49.34	-24.66	74.00	PEAK	H
2	4924.00	6.99	30.64	37.63	-16.37	54.00	AVG	H
1	4924.00	6.99	41.15	48.14	-25.86	74.00	PEAK	V
2	4924.00	6.99	30.25	37.24	-16.76	54.00	AVG	V

Note:

1. All Readings below 1GHz are Quasi-Peak, above are performed with peak and/or average measurements as necessary.
2. Measurement Level = Reading Level + Correct Factor



Limit : FCC_CLASS_B_03M_QP	Margin : 6
Test mode: Transmit by 802.11n (HT-20 at 2.4GHz band) channel 1	Probe : VERTICAL/ HORIZONTAL
Power : AC 120V/60Hz	

	Frequency (MHz)	Correct Factor (dB)	Reading Level (dBuV)	Measure Level (dBuV/m)	Margin (dB)	Limit (dBuV/m)	Detector Type	Antenna Pole (V/H)
1	4824.00	6.53	42.39	48.92	-25.08	74.00	PEAK	H
2	4824.00	6.53	29.68	36.21	-17.79	54.00	AVG	H
1	4824.00	6.53	42.59	49.12	-24.88	74.00	PEAK	V
2	4824.00	6.53	29.48	36.01	-17.99	54.00	AVG	V

Note:

1. All Readings below 1GHz are Quasi-Peak, above are performed with peak and/or average measurements as necessary.
2. Measurement Level = Reading Level + Correct Factor

Limit : FCC_CLASS_B_03M_QP	Margin : 6
Test mode: Transmit by 802.11n (HT-20 at 2.4GHz band) channel 6	Probe : VERTICAL/ HORIZONTAL
Power : AC 120V/60Hz	

	Frequency (MHz)	Correct Factor (dB)	Reading Level (dBuV)	Measure Level (dBuV/m)	Margin (dB)	Limit (dBuV/m)	Detector Type	Antenna Pole (V/H)
1	4874.00	6.85	42.38	49.23	-24.77	74.00	PEAK	H
2	4874.00	6.85	29.84	36.69	-17.31	54.00	AVG	H
1	4874.00	6.85	42.48	49.33	-24.67	74.00	PEAK	V
2	4874.00	6.85	29.84	36.69	-17.31	54.00	AVG	V

Note:

1. All Readings below 1GHz are Quasi-Peak, above are performed with peak and/or average measurements as necessary.
2. Measurement Level = Reading Level + Correct Factor





Limit : FCC_CLASS_B_03M_QP	Margin : 6
Test mode: Transmit by 802.11n (HT-20 at 2.4GHz band) channel 11	Probe : VERTICAL/ HORIZONTAL
Power : AC 120V/60Hz	

	Frequency (MHz)	Correct Factor (dB)	Reading Level (dBuV)	Measure Level (dBuV/m)	Margin (dB)	Limit (dBuV/m)	Detector Type	Antenna Pole (V/H)
1	4924.00	6.99	43.28	50.27	-23.73	74.00	PEAK	H
2	4924.00	6.99	29.84	36.83	-17.17	54.00	AVG	H
1	4924.00	6.99	41.36	48.35	-25.65	74.00	PEAK	V
2	4924.00	6.99	29.47	36.46	-17.54	54.00	AVG	V

Note:

1. All Readings below 1GHz are Quasi-Peak, above are performed with peak and/or average measurements as necessary.
2. Measurement Level = Reading Level + Correct Factor

Limit : FCC_CLASS_B_03M_QP	Margin : 6
Test mode: Transmit by 802.11n(HT-40 at 2.4GHz band) channel 3	Probe : VERTICAL/ HORIZONTAL
Power : AC 120V/60Hz	

	Frequency (MHz)	Correct Factor (dB)	Reading Level (dBuV)	Measure Level (dBuV/m)	Margin (dB)	Limit (dBuV/m)	Detector Type	Antenna Pole (V/H)
1	4844.00	6.61	41.25	47.86	-26.14	74.00	PEAK	H
2	4844.00	6.61	30.48	37.09	-16.91	54.00	AVG	H
1	4844.00	6.61	42.38	48.99	-25.01	74.00	PEAK	V
2	4844.00	6.61	30.07	36.68	-17.32	54.00	AVG	V

Note:

1. All Readings below 1GHz are Quasi-Peak, above are performed with peak and/or average measurements as necessary.
2. Measurement Level = Reading Level + Correct Factor



Limit : FCC_CLASS_B_03M_QP	Margin : 6
Test mode: Transmit by 802.11n(HT-40 at 2.4GHz band) channel 6	Probe : VERTICAL/ HORIZONTAL
Power : AC 120V/60Hz	

	Frequency (MHz)	Correct Factor (dB)	Reading Level (dBuV)	Measure Level (dBuV/m)	Margin (dB)	Limit (dBuV/m)	Detector Type	Antenna Pole (V/H)
1	4874.00	6.85	41.39	48.24	-25.76	74.00	PEAK	H
2	4874.00	6.85	29.84	36.69	-17.31	54.00	AVG	H
1	4874.00	6.85	43.15	50.00	-24.00	74.00	PEAK	V
2	4874.00	6.85	30.47	37.32	-16.68	54.00	AVG	V

Note:

1. All Readings below 1GHz are Quasi-Peak, above are performed with peak and/or average measurements as necessary.
2. Measurement Level = Reading Level + Correct Factor

Limit : FCC_CLASS_B_03M_QP	Margin : 6
Test mode: Transmit by 802.11n(HT-40 at 2.4GHz band) channel 9	Probe : VERTICAL/ HORIZONTAL
Power : AC 120V/60Hz	

	Frequency (MHz)	Correct Factor (dB)	Reading Level (dBuV)	Measure Level (dBuV/m)	Margin (dB)	Limit (dBuV/m)	Detector Type	Antenna Pole (V/H)
1	4904.00	6.92	41.38	48.30	-25.70	74.00	PEAK	H
2	4904.00	6.92	28.89	35.81	-18.19	54.00	AVG	H
1	4904.00	6.92	43.04	49.96	-24.04	74.00	PEAK	V
2	4904.00	6.92	30.15	37.07	-16.93	54.00	AVG	V

Note:

1. All Readings below 1GHz are Quasi-Peak, above are performed with peak and/or average measurements as necessary.
2. Measurement Level = Reading Level + Correct Factor



Limit : FCC_CLASS_B_03M_QP	Margin : 6
Test mode: Transmit by 802.11a channel 149	Probe : VERTICAL/ HORIZONTAL
Power : AC 120V/60Hz	

	Frequency (MHz)	Correct Factor (dB)	Reading Level (dBuV)	Measure Level (dBuV/m)	Margin (dB)	Limit (dBuV/m)	Detector Type	Antenna Pole (V/H)
1	11490.00	21.98	34.05	56.03	-17.97	74.00	PEAK	H
2	11490.00	21.98	23.25	45.23	-8.77	54.00	AVG	H
1	11490.00	21.98	36.48	58.46	-15.54	74.00	PEAK	V
2	11490.00	21.98	23.41	45.39	-8.61	54.00	AVG	V

Note:

1. All Readings below 1GHz are Quasi-Peak, above are performed with peak and/or average measurements as necessary.
2. Measurement Level = Reading Level + Correct Factor

Limit : FCC_CLASS_B_03M_QP	Margin : 6
Test mode: Transmit by 802.11a channel 157	Probe : VERTICAL/ HORIZONTAL
Power : AC 120V/60Hz	

	Frequency (MHz)	Correct Factor (dB)	Reading Level (dBuV)	Measure Level (dBuV/m)	Margin (dB)	Limit (dBuV/m)	Detector Type	Antenna Pole (V/H)
1	11570.00	21.79	36.42	58.21	-15.79	74.00	PEAK	H
2	11570.00	21.79	22.38	44.17	-9.83	54.00	AVG	H
1	11570.00	21.79	35.78	57.57	-16.43	74.00	PEAK	V
2	11570.00	21.79	23.65	45.44	-8.56	54.00	AVG	V

Note:

1. All Readings below 1GHz are Quasi-Peak, above are performed with peak and/or average measurements as necessary.
2. Measurement Level = Reading Level + Correct Factor



Limit : FCC_CLASS_B_03M_QP	Margin : 6
Test mode: Transmit by 802.11a channel 165	Probe : VERTICAL/ HORIZONTAL
Power : AC 120V/60Hz	

	Frequency (MHz)	Correct Factor (dB)	Reading Level (dBuV)	Measure Level (dBuV/m)	Margin (dB)	Limit (dBuV/m)	Detector Type	Antenna Pole (V/H)
1	11650.00	21.56	34.25	55.81	-18.19	74.00	PEAK	H
2	11650.00	21.56	24.48	46.04	-7.96	54.00	AVG	H
1	11650.00	21.56	35.74	57.30	-16.70	74.00	PEAK	V
2	11650.00	21.56	25.84	47.40	-6.60	54.00	AVG	V

Note:

1. All Readings below 1GHz are Quasi-Peak, above are performed with peak and/or average measurements as necessary.
2. Measurement Level = Reading Level + Correct Factor

Limit : FCC_CLASS_B_03M_QP	Margin : 6
Test mode: Transmit by 802.11n( HT-20 at 5GHz band) channel 149	Probe : VERTICAL/ HORIZONTAL
Power : AC 120V/60Hz	

	Frequency (MHz)	Correct Factor (dB)	Reading Level (dBuV)	Measure Level (dBuV/m)	Margin (dB)	Limit (dBuV/m)	Detector Type	Antenna Pole (V/H)
1	11490.00	21.98	34.15	56.13	-17.87	74.00	PEAK	H
2	11490.00	21.98	23.98	45.96	-8.04	54.00	AVG	H
1	11490.00	21.98	34.10	56.08	-17.92	74.00	PEAK	V
2	11490.00	21.98	23.58	45.56	-8.44	54.00	AVG	V

Note:

1. All Readings below 1GHz are Quasi-Peak, above are performed with peak and/or average measurements as necessary.
2. Measurement Level = Reading Level + Correct Factor



Limit : FCC_CLASS_B_03M_QP	Margin : 6
Test mode: Transmit by 802.11 n( HT-20 at 5GHz band) channel 157	Probe : VERTICAL/ HORIZONTAL
Power : AC 120V/60Hz	

	Frequency (MHz)	Correct Factor (dB)	Reading Level (dBuV)	Measure Level (dBuV/m)	Margin (dB)	Limit (dBuV/m)	Detector Type	Antenna Pole (V/H)
1	11570.00	21.79	35.14	56.93	-17.07	74.00	PEAK	H
2	11570.00	21.79	23.14	44.93	-9.07	54.00	AVG	H
1	11570.00	21.79	33.58	55.37	-18.63	74.00	PEAK	V
2	11570.00	21.79	22.48	44.27	-9.73	54.00	AVG	V

Note:

1. All Readings below 1GHz are Quasi-Peak, above are performed with peak and/or average measurements as necessary.
2. Measurement Level = Reading Level + Correct Factor

Limit : FCC_CLASS_B_03M_QP	Margin : 6
Test mode: Transmit by 802.11 n( HT-20 at 5GHz band) channel 165	Probe : VERTICAL/ HORIZONTAL
Power : AC 120V/60Hz	

	Frequency (MHz)	Correct Factor (dB)	Reading Level (dBuV)	Measure Level (dBuV/m)	Margin (dB)	Limit (dBuV/m)	Detector Type	Antenna Pole (V/H)
1	11650.00	21.56	34.65	56.21	-17.79	74.00	PEAK	H
2	11650.00	21.56	22.58	44.14	-9.86	54.00	AVG	H
1	11650.00	21.56	33.56	55.12	-18.88	74.00	PEAK	V
2	11650.00	21.56	24.11	45.67	-8.33	54.00	AVG	V

Note:

1. All Readings below 1GHz are Quasi-Peak, above are performed with peak and/or average measurements as necessary.
2. Measurement Level = Reading Level + Correct Factor



Limit : FCC_CLASS_B_03M_QP	Margin : 6
Test mode: Transmit by 802.11 n( HT-40 at 5GHz band) channel 151	Probe : VERTICAL/ HORIZONTAL
Power : AC 120V/60Hz	

	Frequency (MHz)	Correct Factor (dB)	Reading Level (dBuV)	Measure Level (dBuV/m)	Margin (dB)	Limit (dBuV/m)	Detector Type	Antenna Pole (V/H)
1	11510.00	21.97	34.18	56.15	-17.85	74.00	PEAK	H
2	11510.00	21.97	22.65	44.62	-9.38	54.00	AVG	H
1	11510.00	21.97	35.48	57.45	-16.55	74.00	PEAK	V
2	11510.00	21.97	23.85	45.82	-8.18	54.00	AVG	V

Note:

1. All Readings below 1GHz are Quasi-Peak, above are performed with peak and/or average measurements as necessary.
2. Measurement Level = Reading Level + Correct Factor

Limit : FCC_CLASS_B_03M_QP	Margin : 6
Test mode: Transmit by 802.11 n( HT-40 at 5GHz band) channel 159	Probe : VERTICAL/ HORIZONTAL
Power : AC 120V/60Hz	

	Frequency (MHz)	Correct Factor (dB)	Reading Level (dBuV)	Measure Level (dBuV/m)	Margin (dB)	Limit (dBuV/m)	Detector Type	Antenna Pole (V/H)
1	11590.00	21.73	34.26	55.99	-18.01	74.00	PEAK	H
2	11590.00	21.73	24.52	46.25	-7.75	54.00	AVG	H
1	11590.00	21.73	36.65	58.38	-15.62	74.00	PEAK	V
2	11590.00	21.73	23.68	45.41	-8.59	54.00	AVG	V

Note:

1. All Readings below 1GHz are Quasi-Peak, above are performed with peak and/or average measurements as necessary.
2. Measurement Level = Reading Level + Correct Factor



## 7. 6dB Bandwidth Measurement Data

### 7.1 Test Limit

The minimum of 6dB Bandwidth Measurement is 0.5 MHz.

### 7.2 Test Procedures

- a. The transmitter output was connected to the spectrum analyzer.
- b. Set RBW of spectrum analyzer to 1~5% of the emission bandwidth and VBW  $\geq$  3x RBW.
- c. The 6 dB bandwidth is defined as the total spectrum the power of which is higher than peak power minus 6 dB.
- d. The 6dB Bandwidth was measured and recorded.

### 7.3 Test Setup Layout

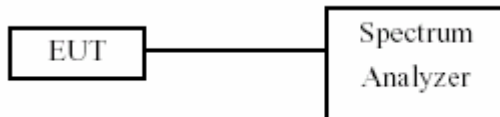



### 7.4 Test Result and Data

Test Item	Occupied Bandwidth
Test Mode	Transmit by 802.11b Chain 0
Test Date	2014-12-10

Channel No.	Frequency (MHz)	Measurement Level (kHz)	Required Limit (kHz)	Result
01	2412	14113	500	Pass
06	2437	14098	500	Pass
11	2462	14099	500	Pass

Channel 01 (2412MHz)

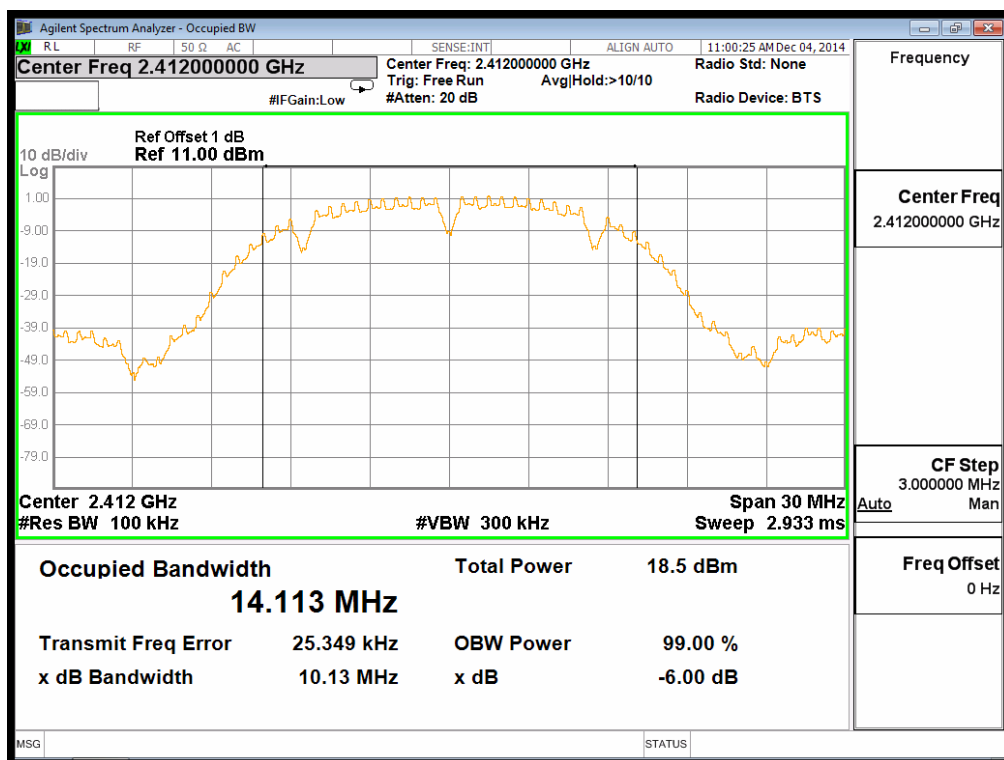





Channel 06 (2437MHz)

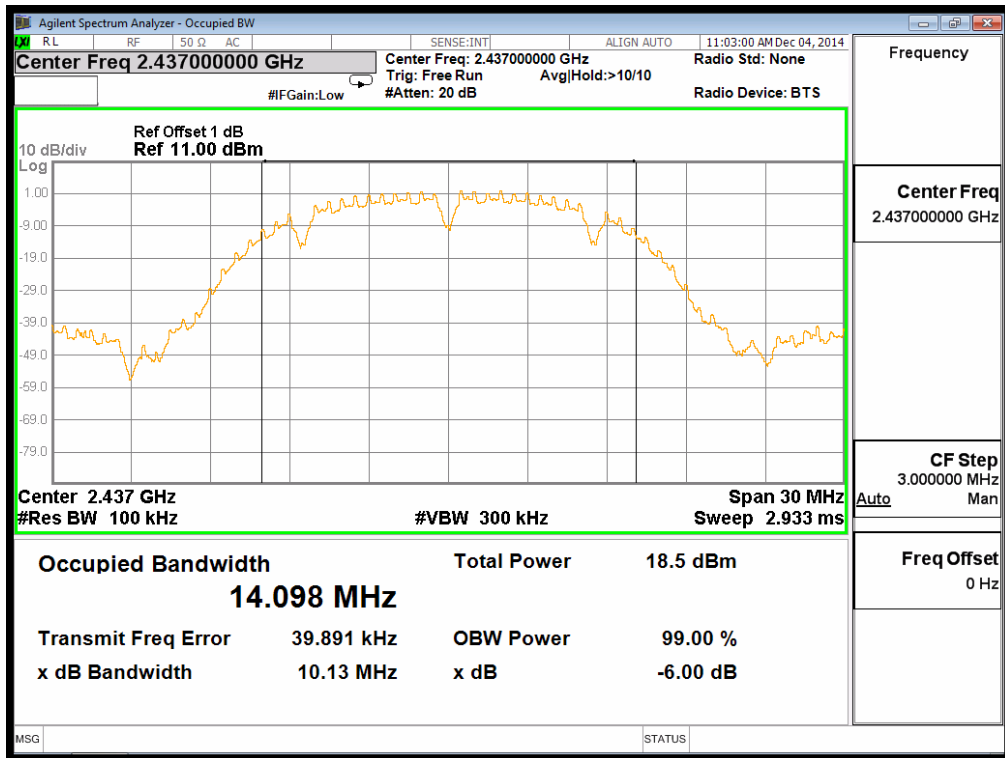

Channel11(2462MHz)

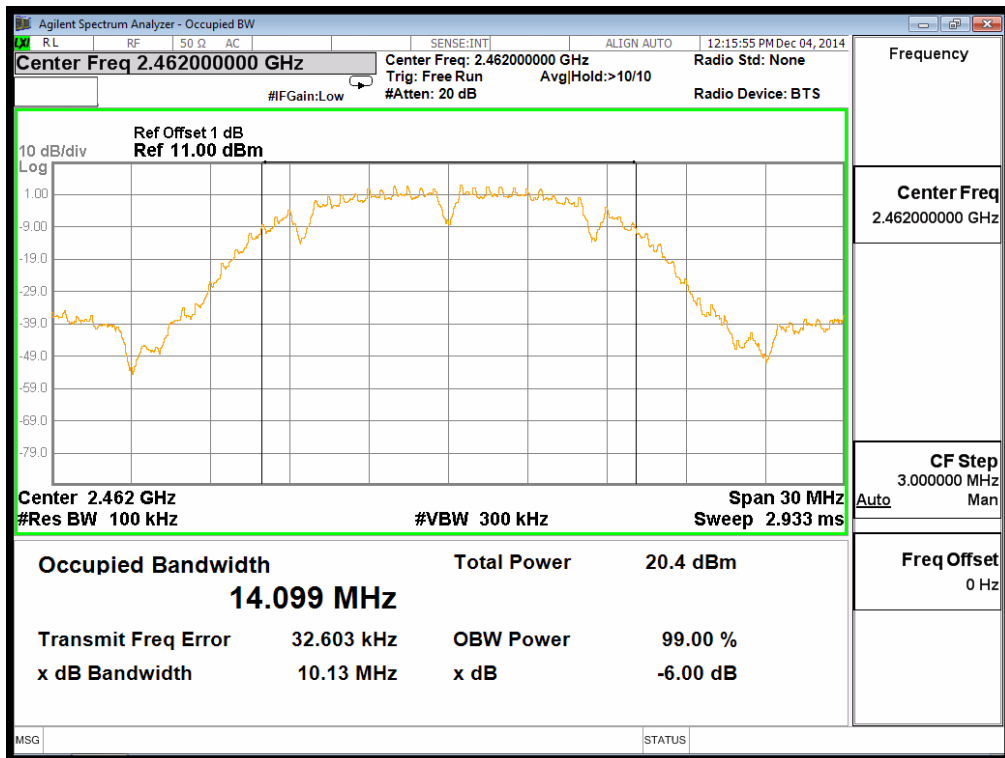



Test Item	Occupied Bandwidth
Test Mode	Transmit by 802.11b Chain 1
Test Date	2014-12-10

Channel No.	Frequency (MHz)	Measurement Level (kHz)	Required Limit (kHz)	Result
01	2412	14000	500	Pass
06	2437	13980	500	Pass
11	2462	13987	500	Pass

Channel 01 (2412MHz)

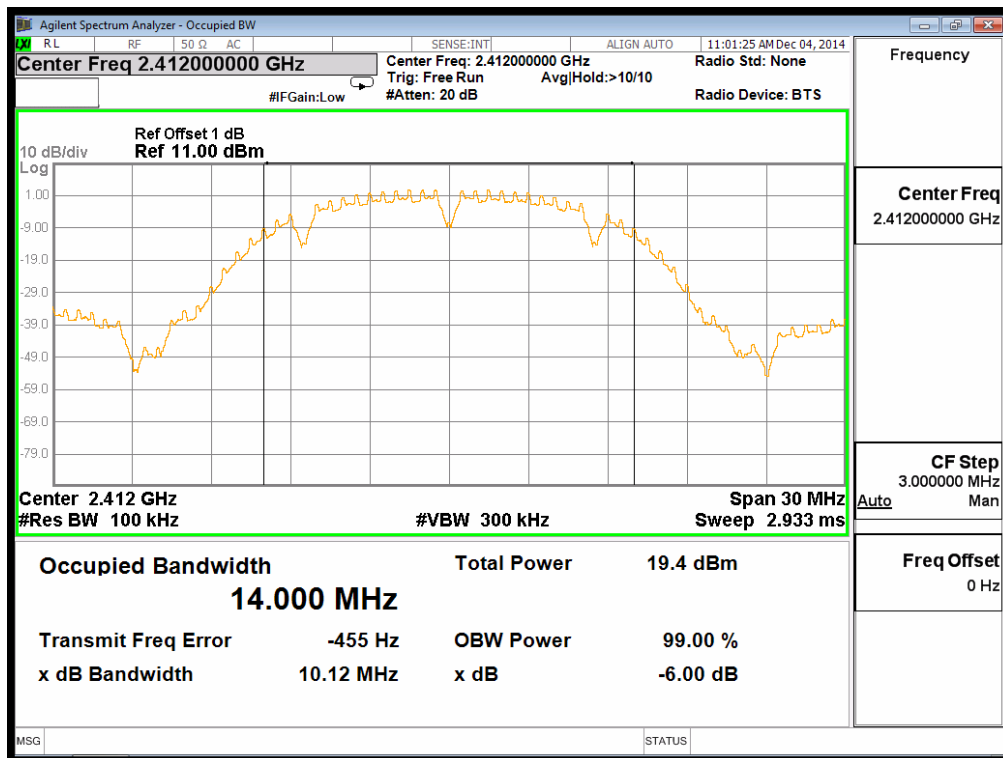



Channel 06 (2437MHz)

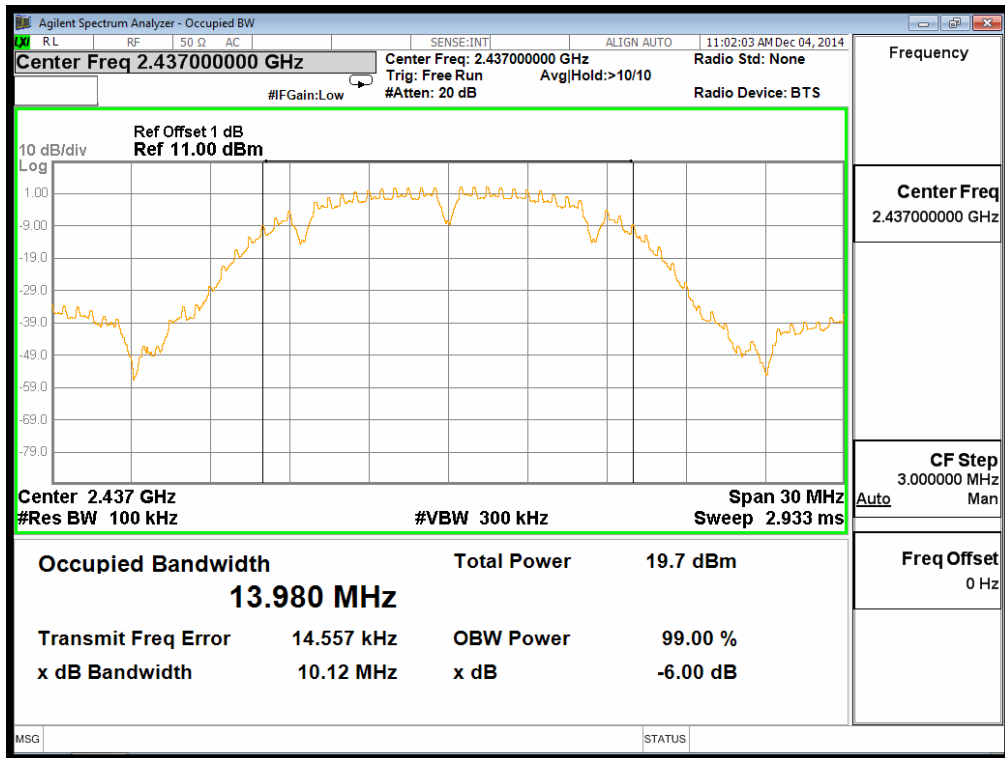

Channel11(2462MHz)

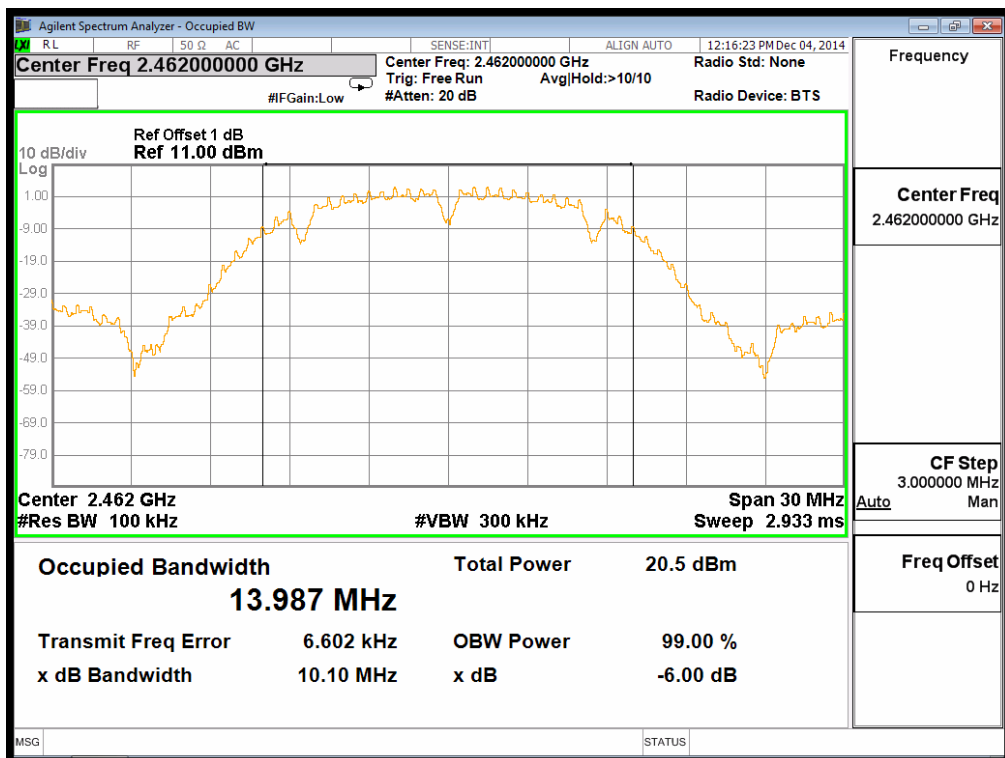



Test Item	Occupied Bandwidth
Test Mode	Transmit by 802.11g Chain 0
Test Date	2014-12-10

Channel No.	Frequency (MHz)	Measurement Level (kHz)	Required Limit (kHz)	Result
01	2412	16546	500	Pass
06	2437	16530	500	Pass
11	2462	16507	500	Pass

Channel 01 (2412MHz)

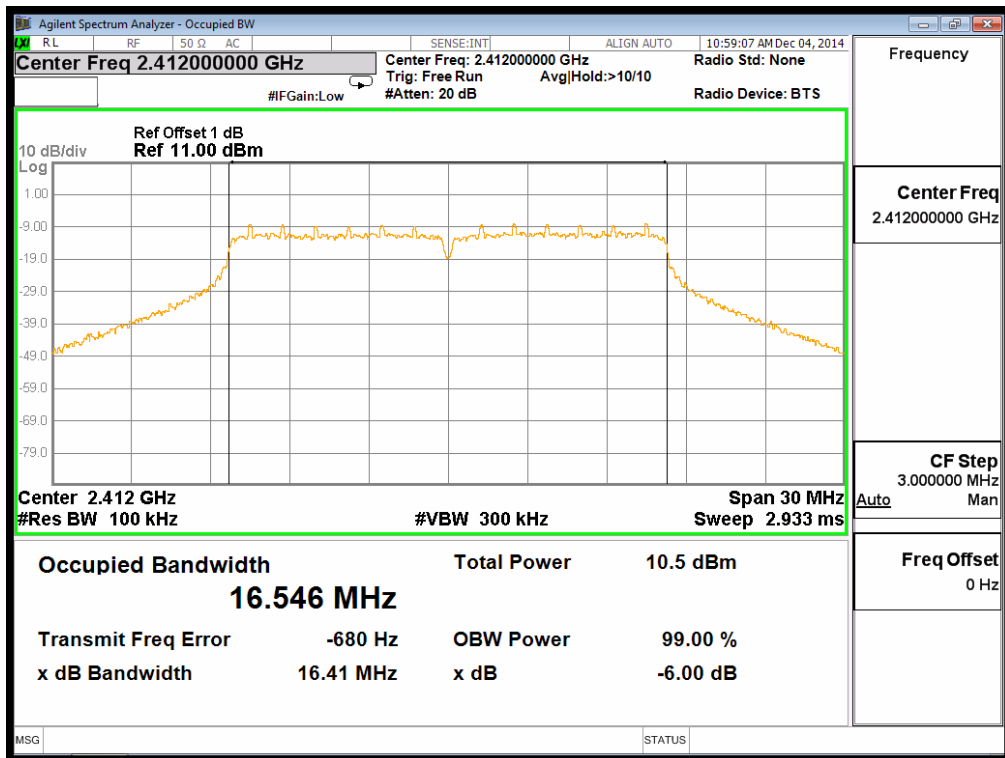



Channel 06 (2437MHz)

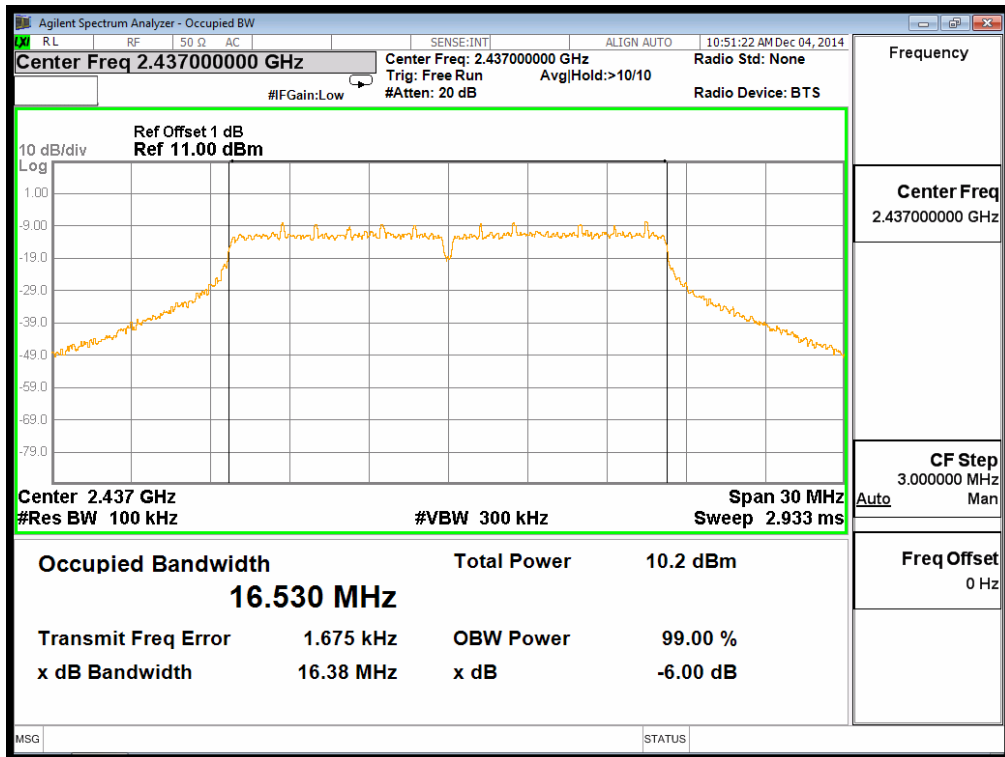

Channel 11 (2462MHz)

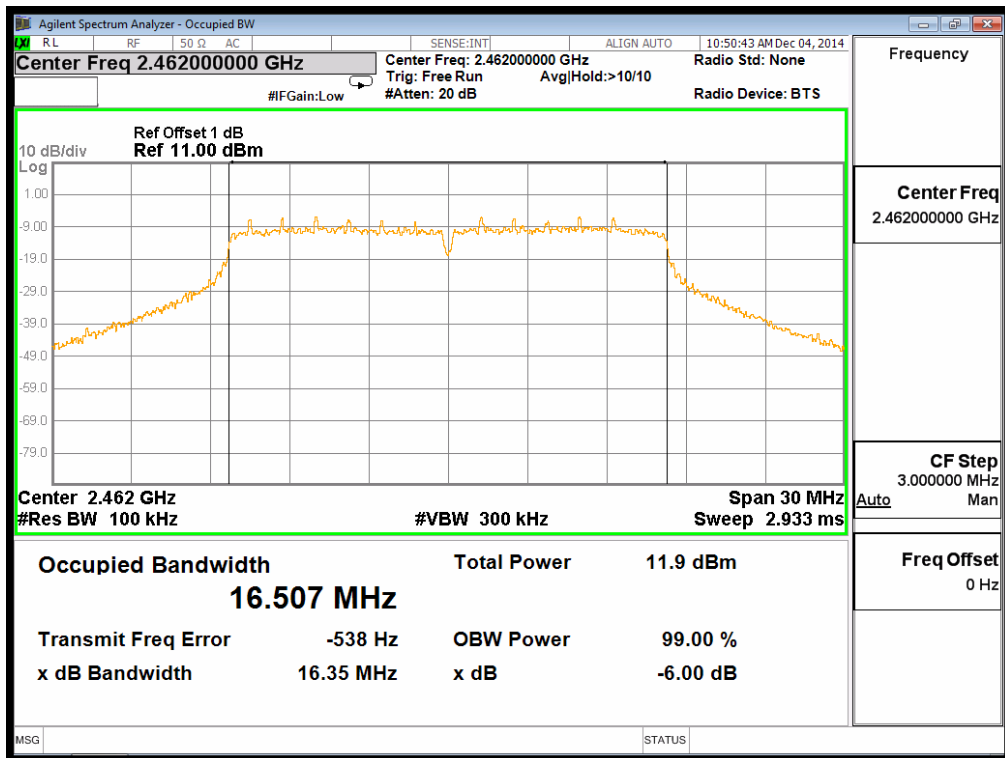



Test Mode	Transmit by 802.11g Chain 1
Test Date	2014-12-10

Channel No.	Frequency (MHz)	Measurement Level (kHz)	Required Limit (kHz)	Result
01	2412	16472	500	Pass
06	2437	16468	500	Pass
11	2462	16471	500	Pass

Channel 01 (2412MHz)

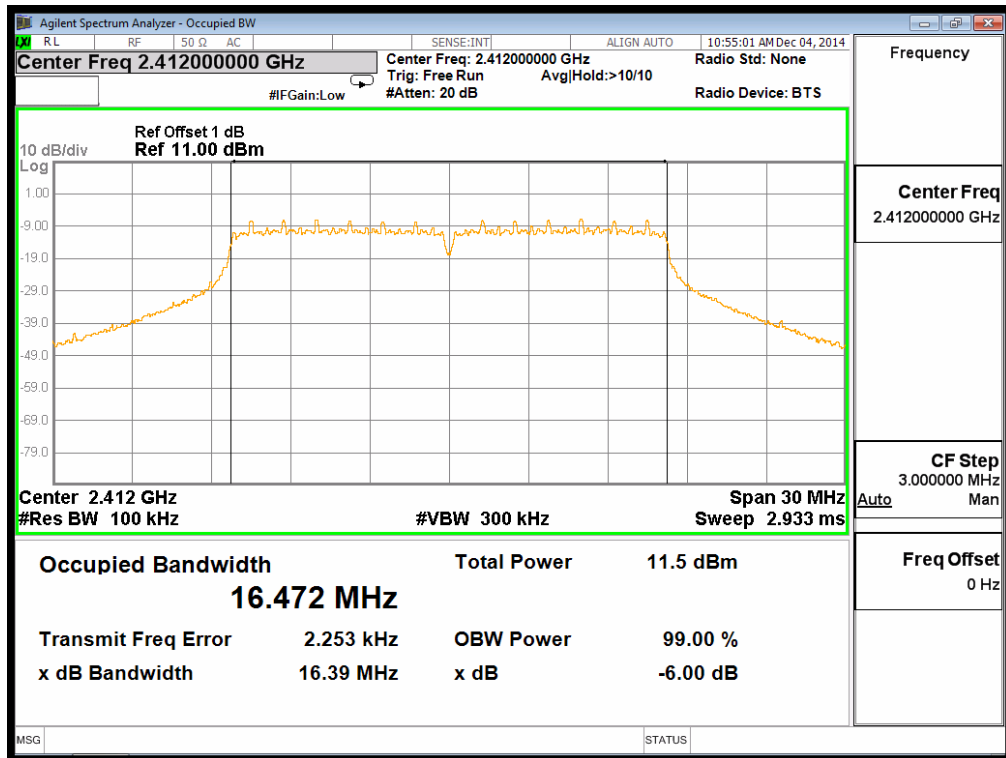



Channel 06 (2437MHz)

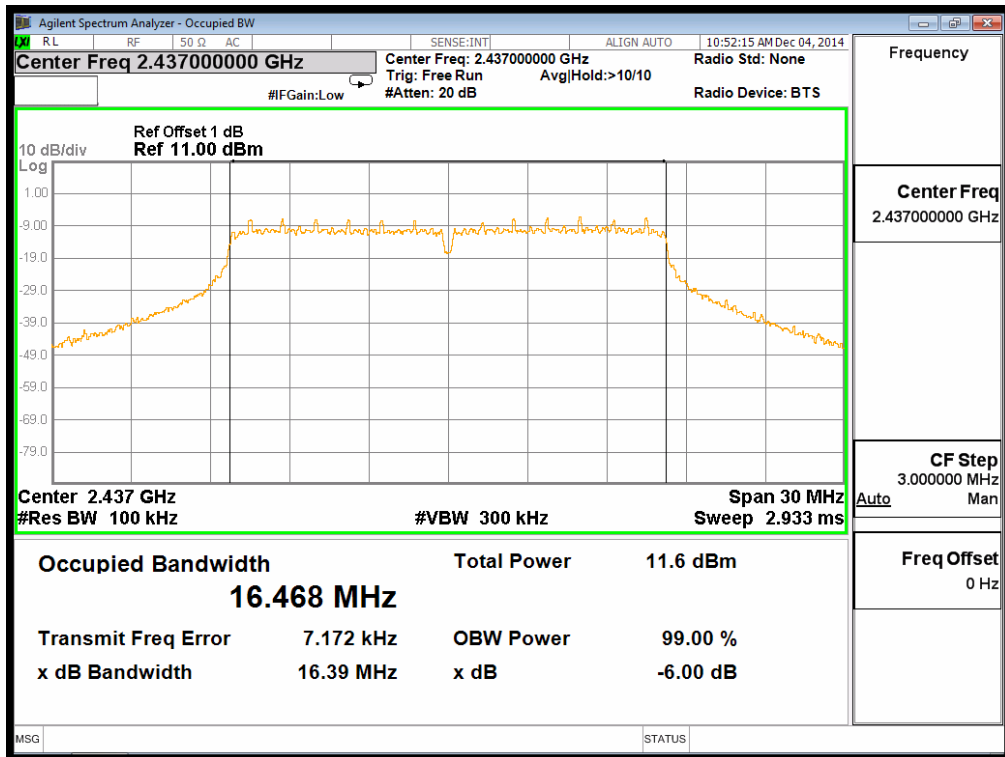

Channel 11 (2462MHz)

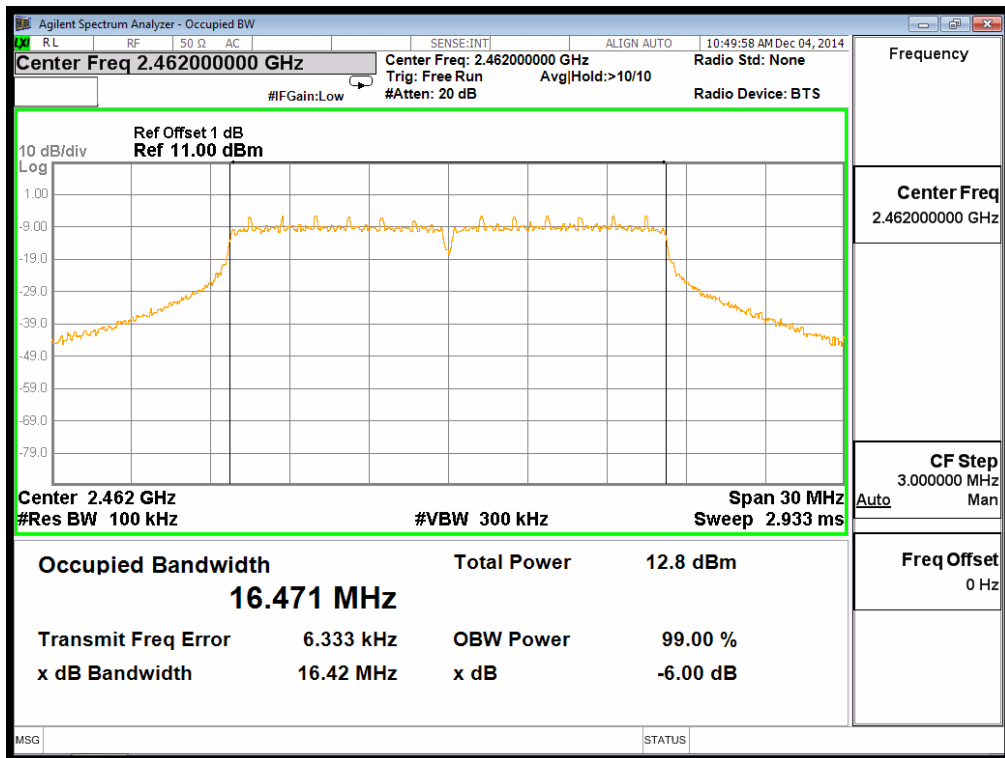



Test Item	Occupied Bandwidth
Test Mode	Transmit by 802.11n HT-20 Chain 0
Test Date	2014-12-10

Channel No.	Frequency (MHz)	Measurement Level (kHz)	Required Limit (kHz)	Result
01	2412	17634	500	Pass
06	2437	17668	500	Pass
11	2462	17609	500	Pass

Channel 01 (2412MHz)

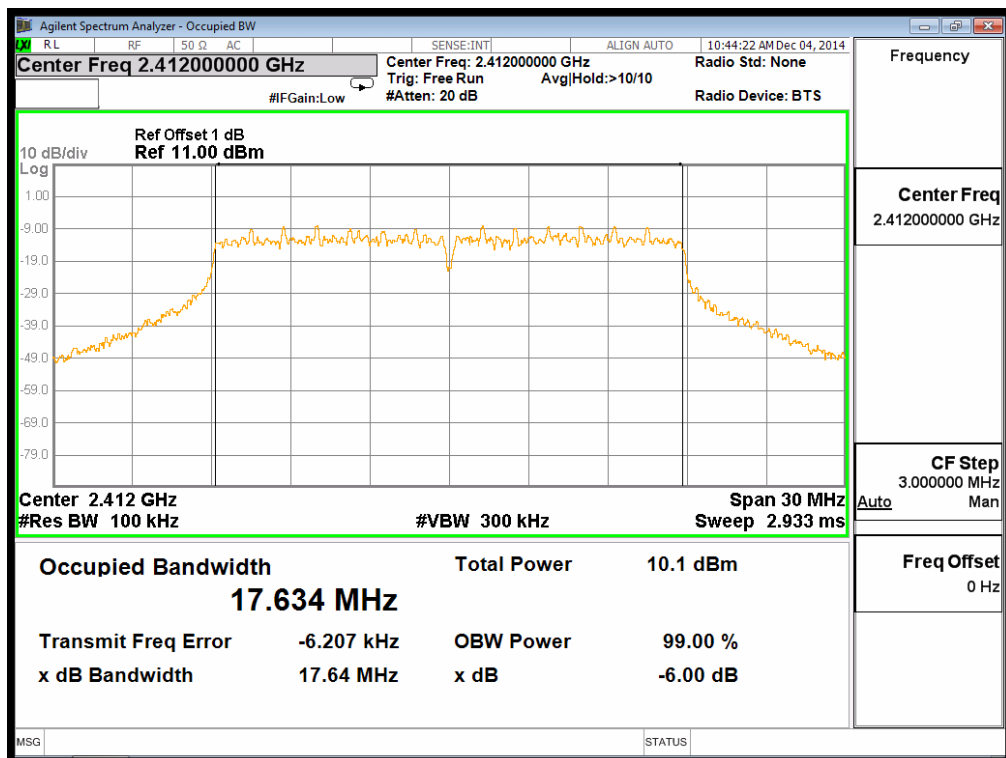





Channel 06 (2437MHz)

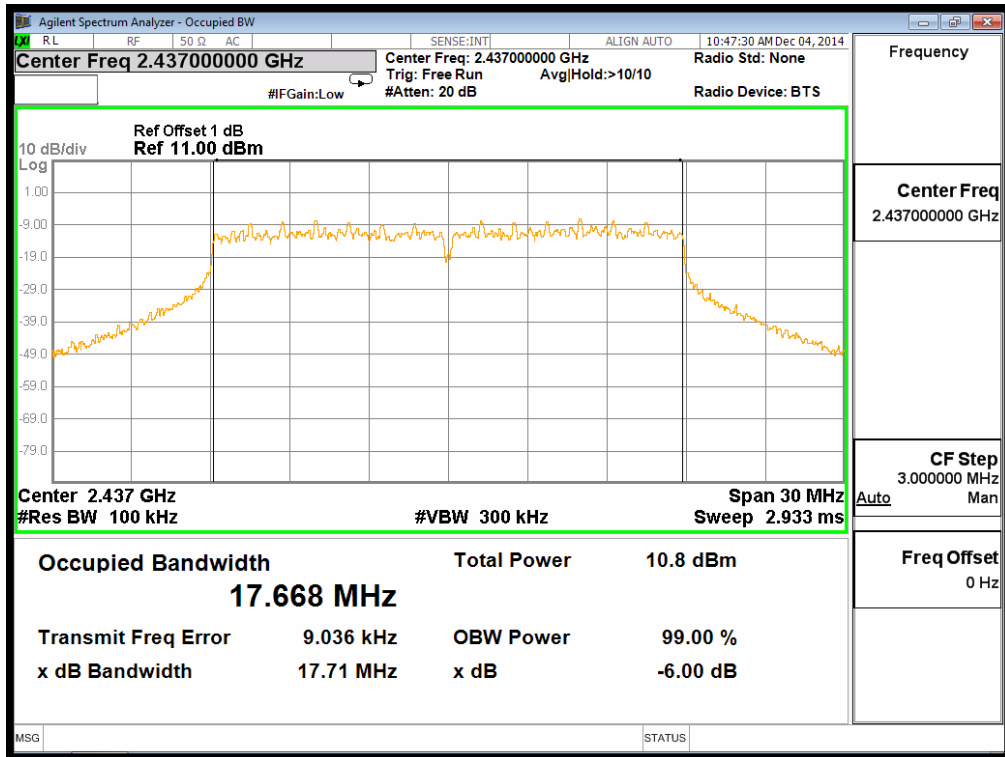

Channel 11 (2462MHz)

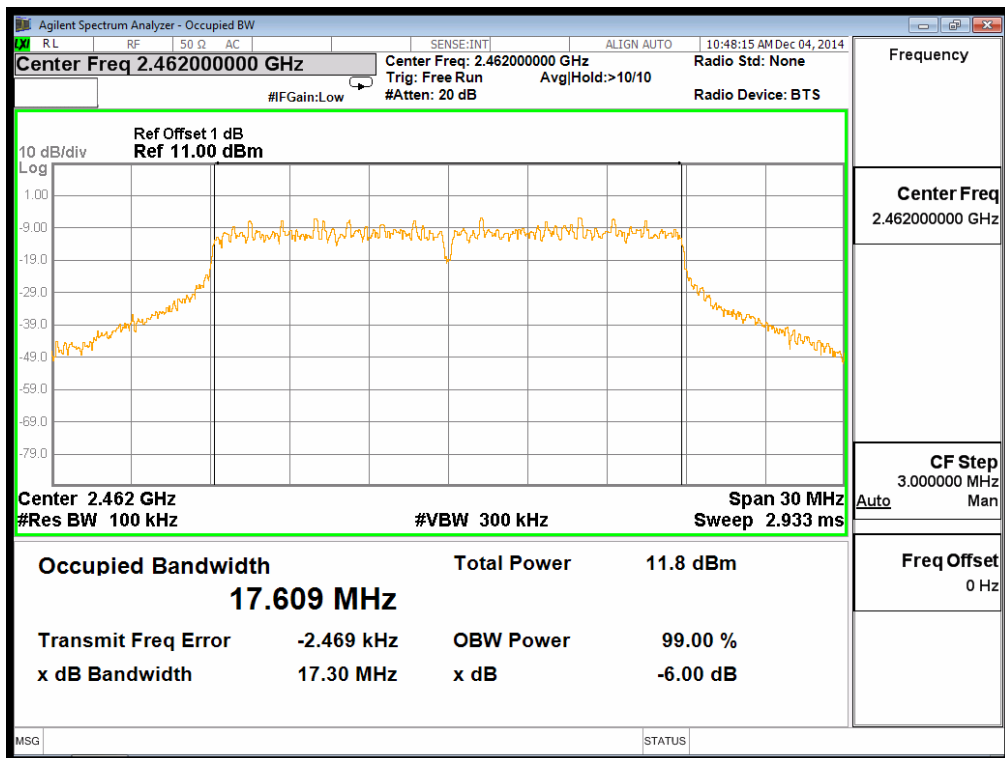



Test Item	Occupied Bandwidth
Test Mode	Transmit by 802.11n HT-20 Chain 1
Test Date	2014-12-10

Channel No.	Frequency (MHz)	Measurement Level (kHz)	Required Limit (kHz)	Result
01	2412	17677	500	Pass
06	2437	17657	500	Pass
11	2462	17690	500	Pass

Channel 01 (2412MHz)

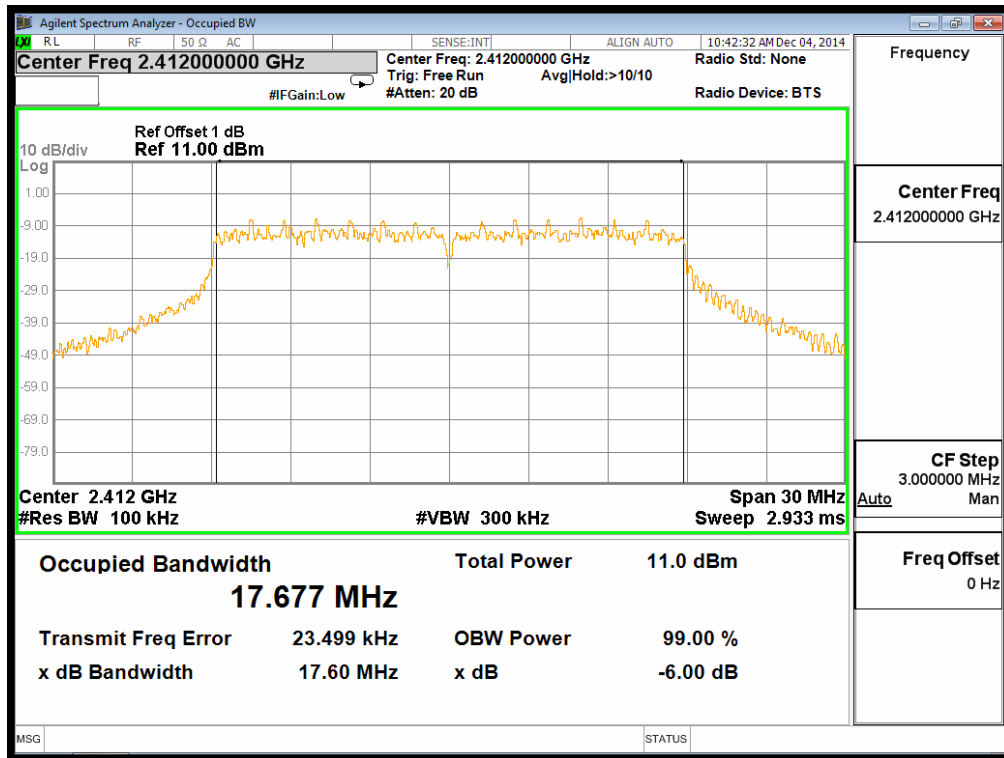



Channel 06 (2437MHz)

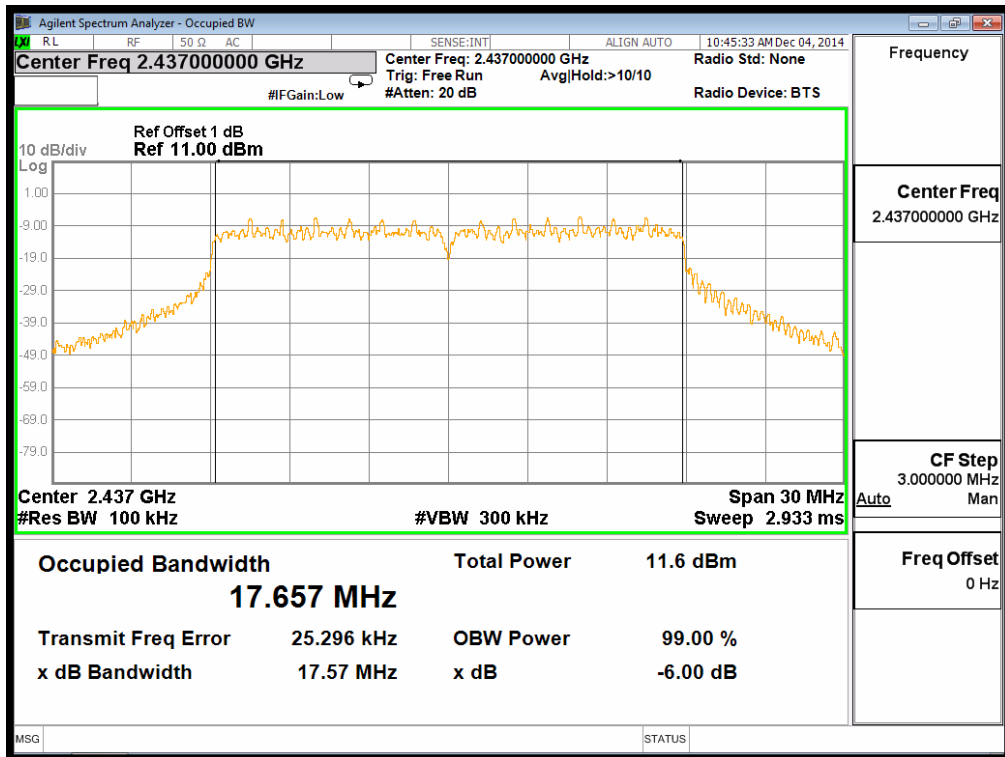

Channel 11 (2462MHz)

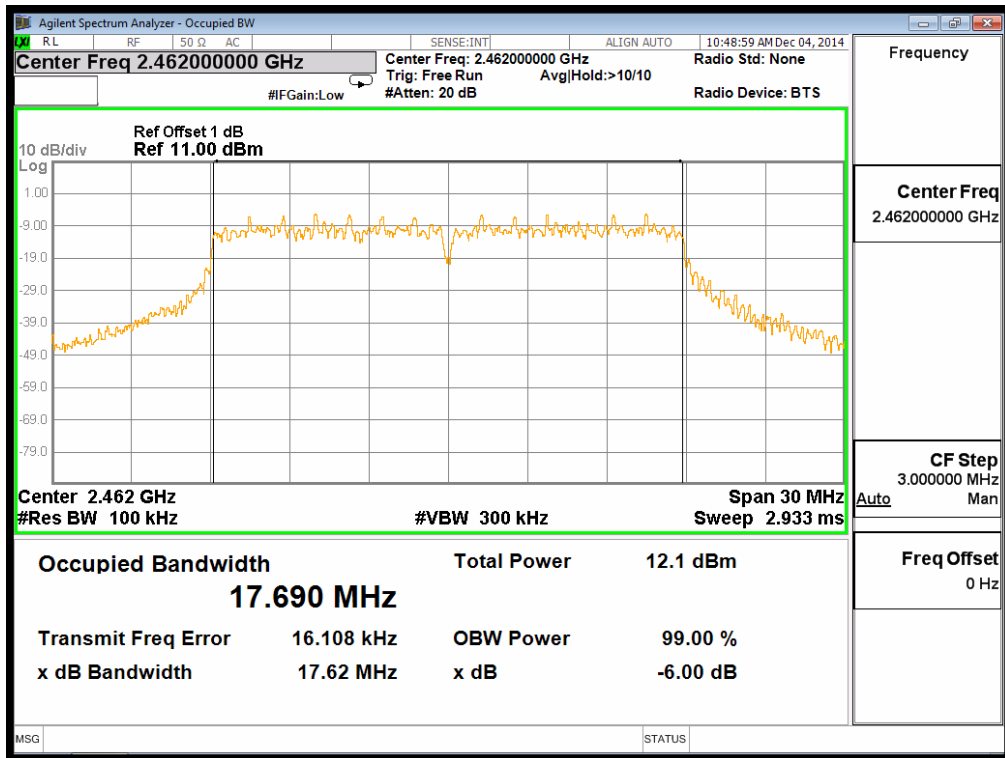



Test Item	Occupied Bandwidth
Test Mode	Transmit by 802.11n HT-40 Chain 0
Test Date	2014-12-10

Channel No.	Frequency (MHz)	Measurement Level (kHz)	Required Limit (kHz)	Result
03	2422	36305	500	Pass
06	2437	36300	500	Pass
09	2452	36241	500	Pass

Channel 03 (2422MHz)

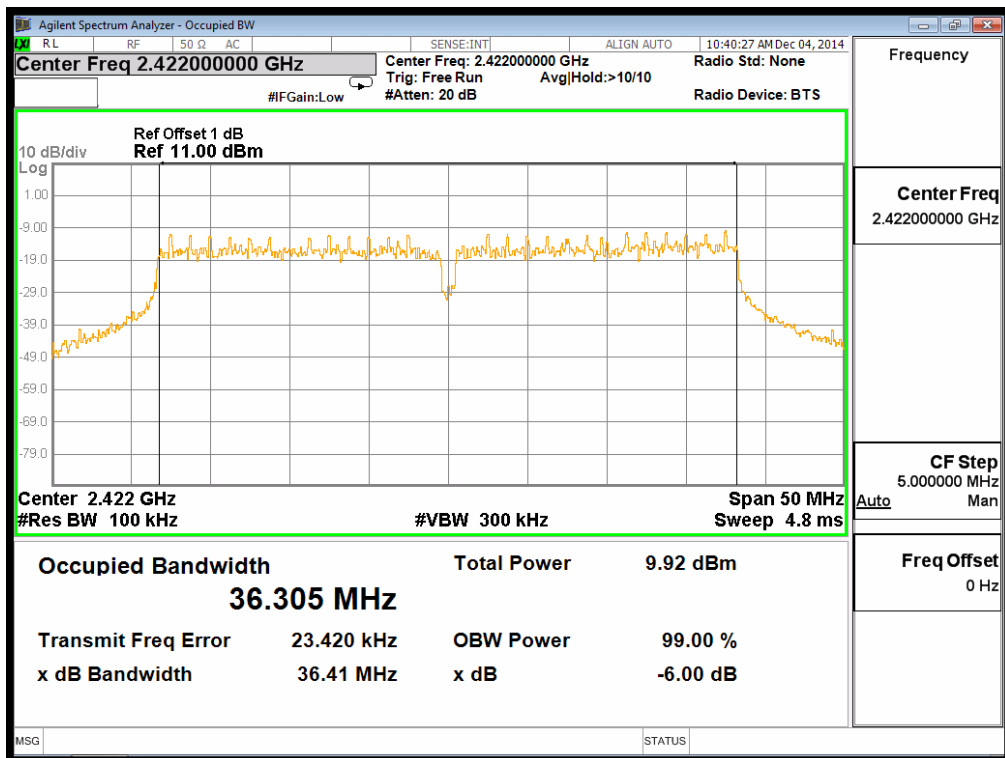



Channel 06 (2437MHz)

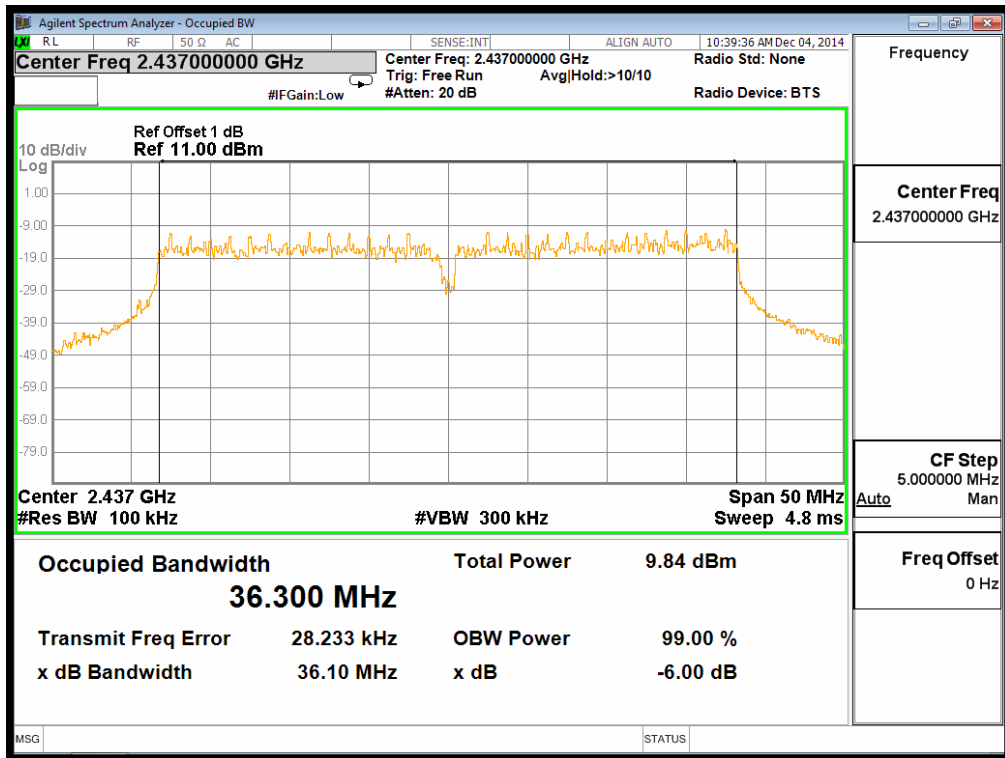

Channel 9 (2452MHz)

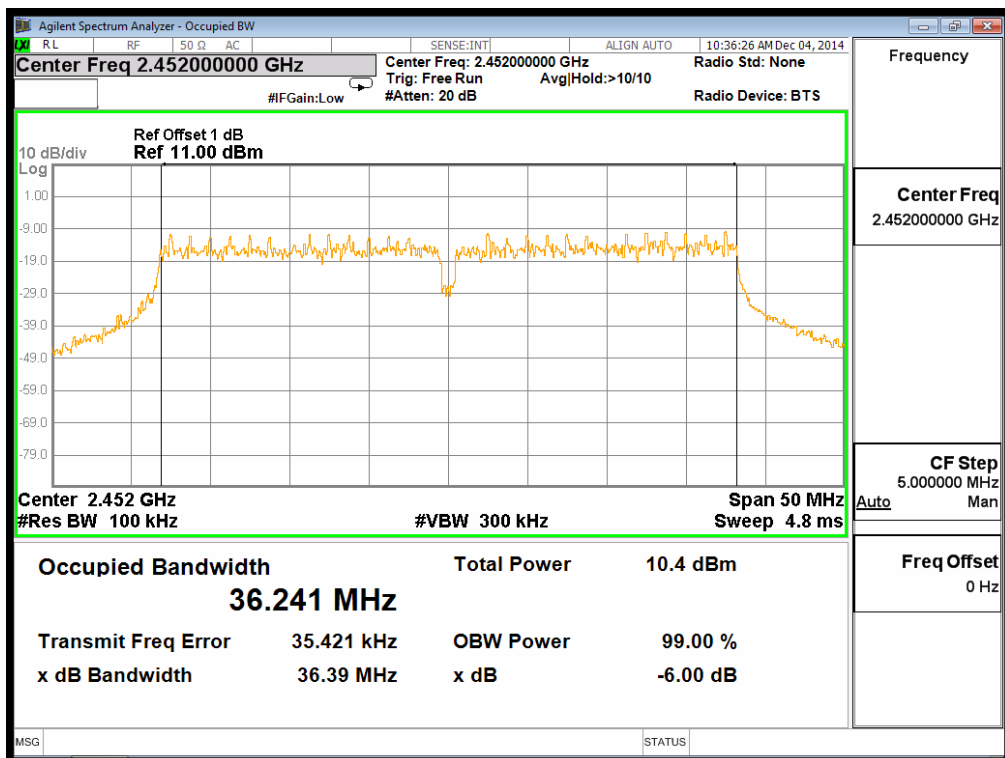



Test Item	Occupied Bandwidth
Test Mode	Transmit by 802.11n HT-40 Chain 1
Test Date	2014-12-10

Channel No.	Frequency (MHz)	Measurement Level (kHz)	Required Limit (kHz)	Result
03	2422	36275	500	Pass
06	2437	36288	500	Pass
09	2452	36312	500	Pass

Channel 03 (2422MHz)

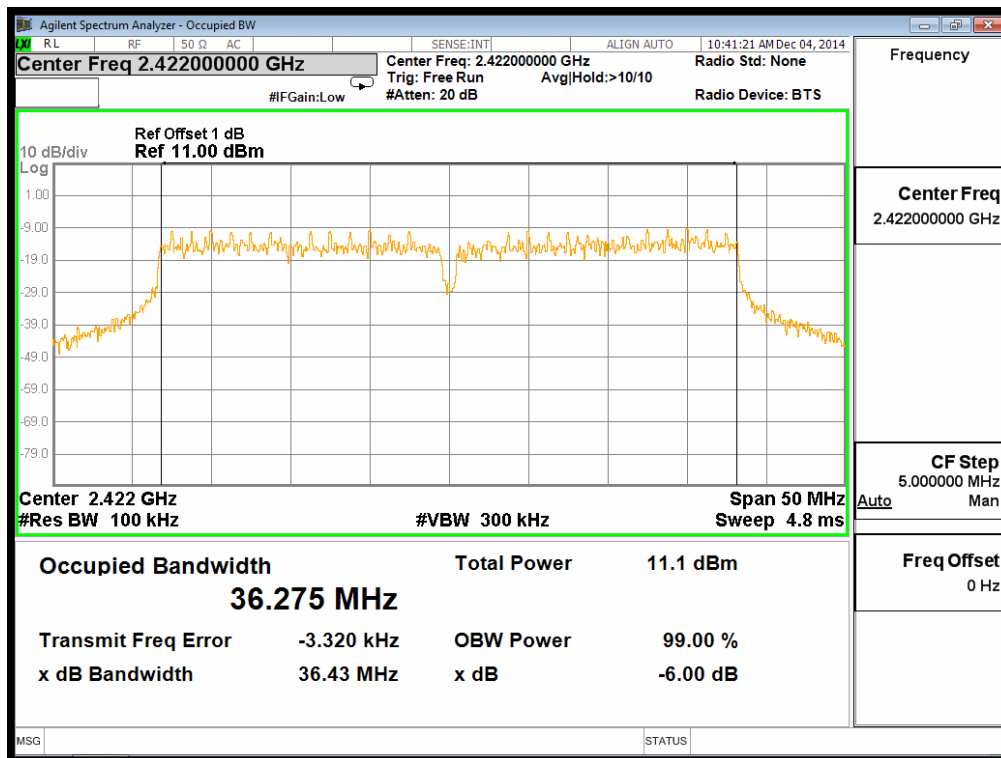



Channel 06 (2437MHz)

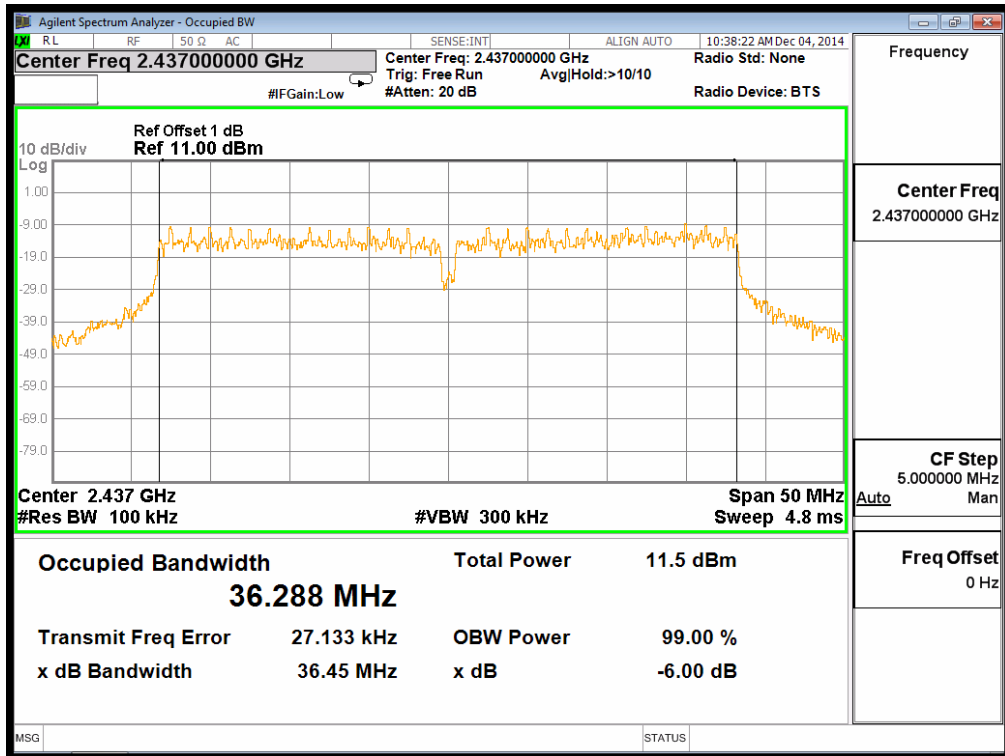

Channel 9 (2452MHz)

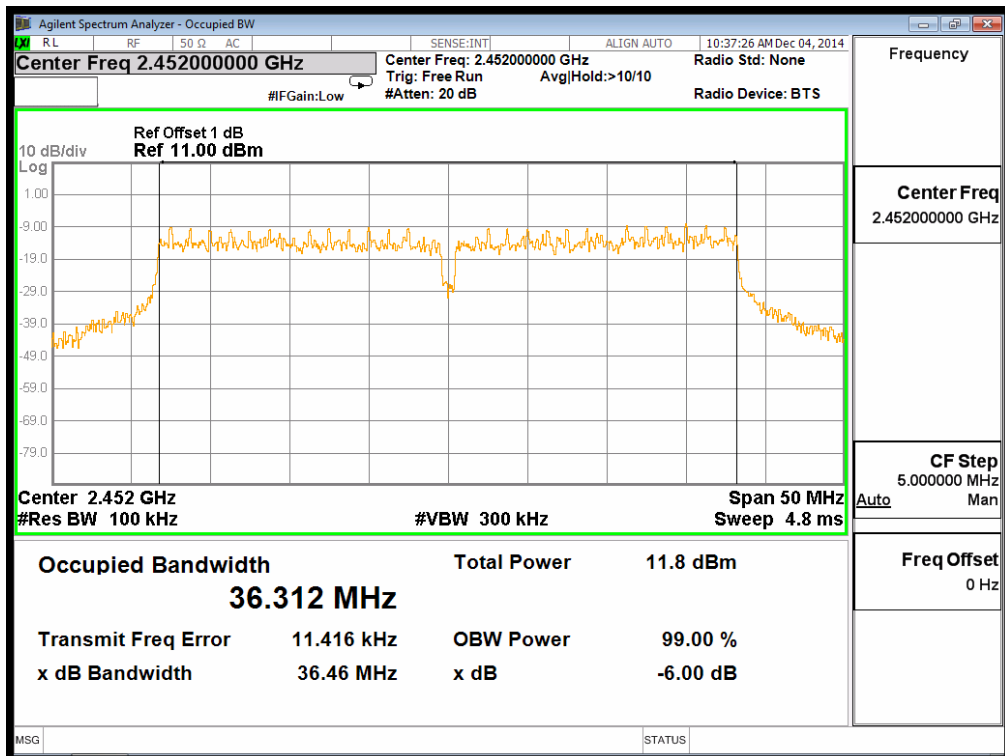



Test Item	Occupied Bandwidth
Test Mode	Transmit by 802.11a Chain 0
Test Date	2014-12-10

Channel No.	Frequency (MHz)	Measurement Level (kHz)	Required Limit (kHz)	Result
149	5745	16429	500	Pass
157	5785	16457	500	Pass
165	5825	16439	500	Pass

Channel 149 (5745MHz)

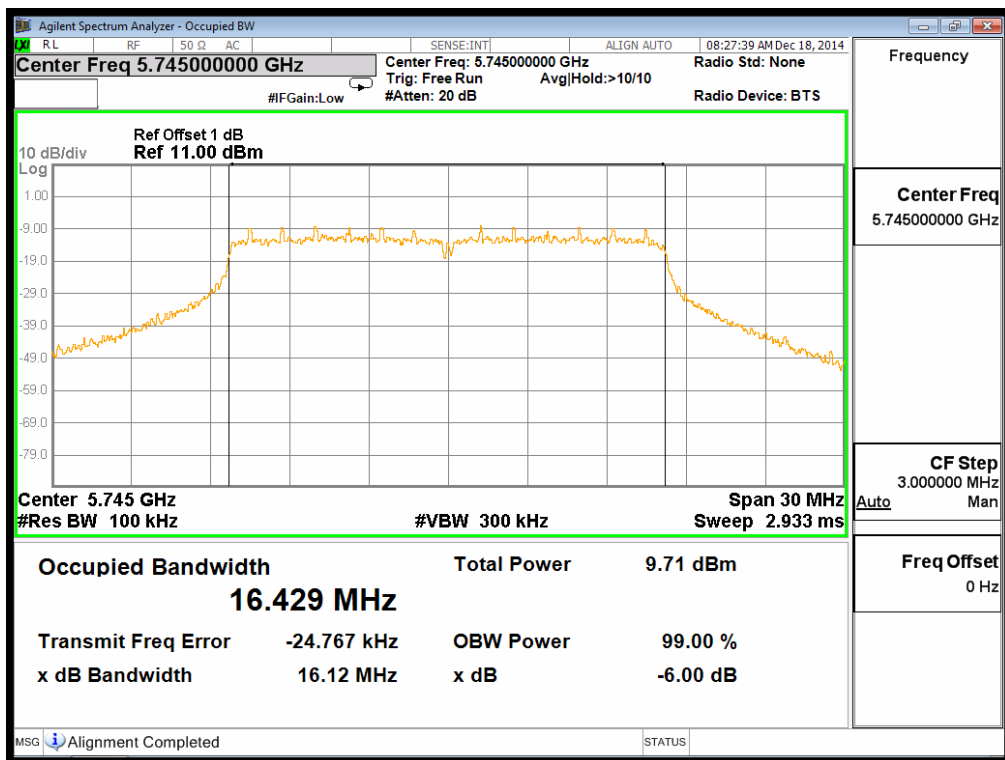





Channel 157 (5785MHz)

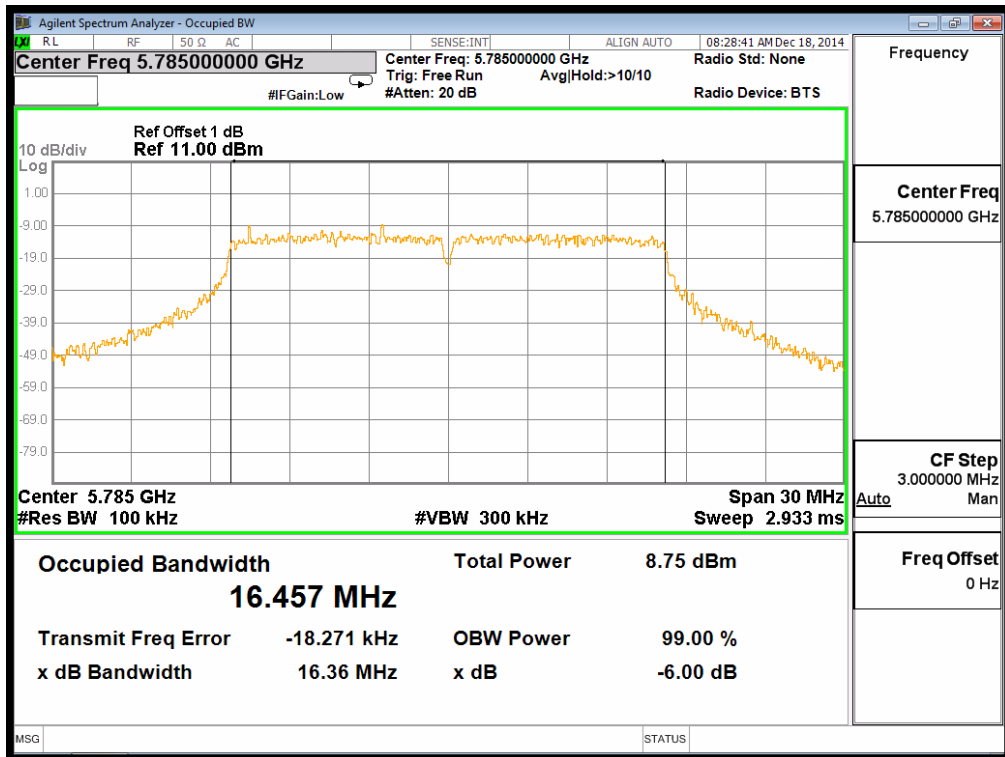

Channel 165 (5825MHz)

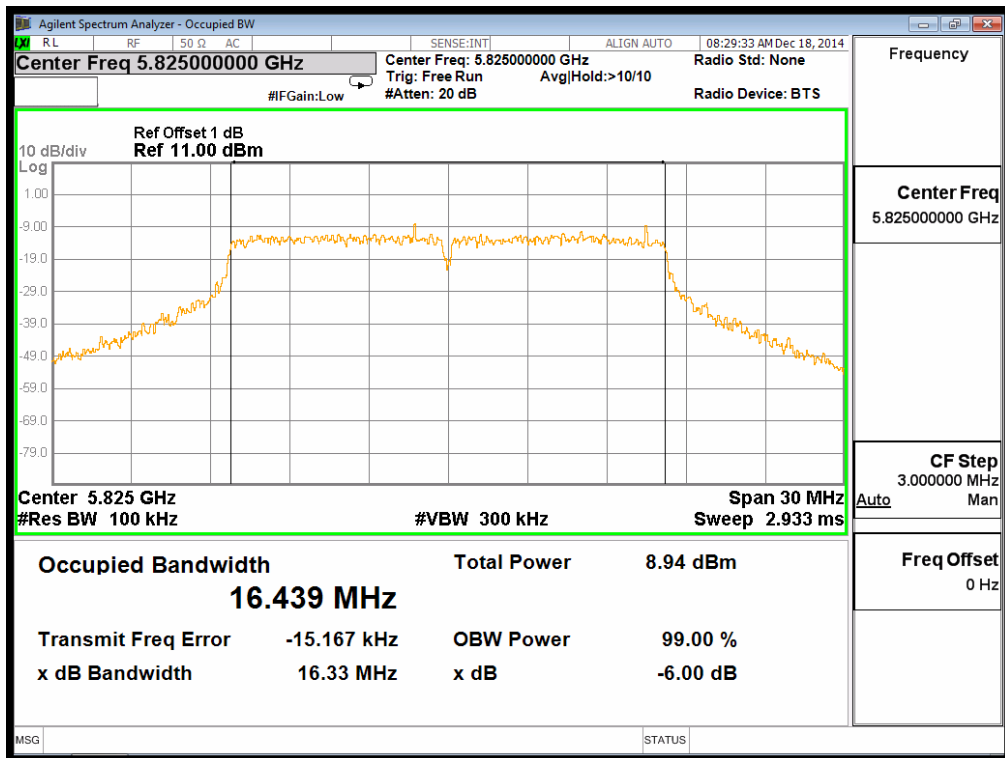



Test Item	Occupied Bandwidth
Test Mode	Transmit by 802.11a Chain 1
Test Date	2014-12-10

Channel No.	Frequency (MHz)	Measurement Level (kHz)	Required Limit (kHz)	Result
149	5745	16431	500	Pass
157	5785	16453	500	Pass
165	5825	16419	500	Pass

Channel 149 (5745MHz)

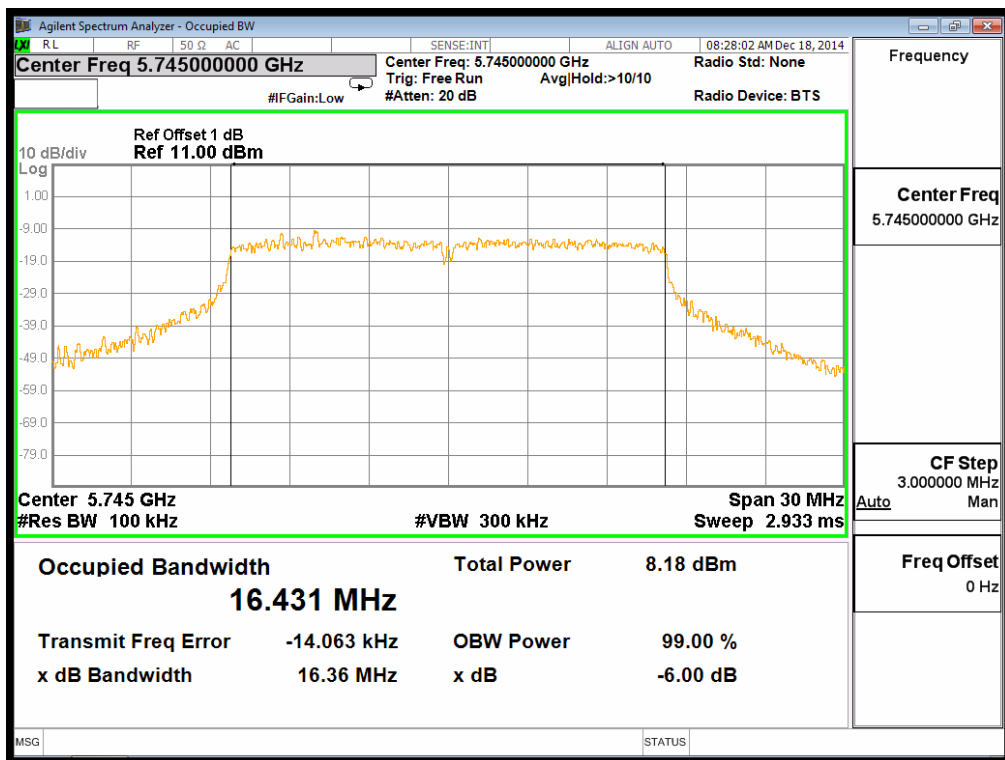



Channel 157 (5785MHz)

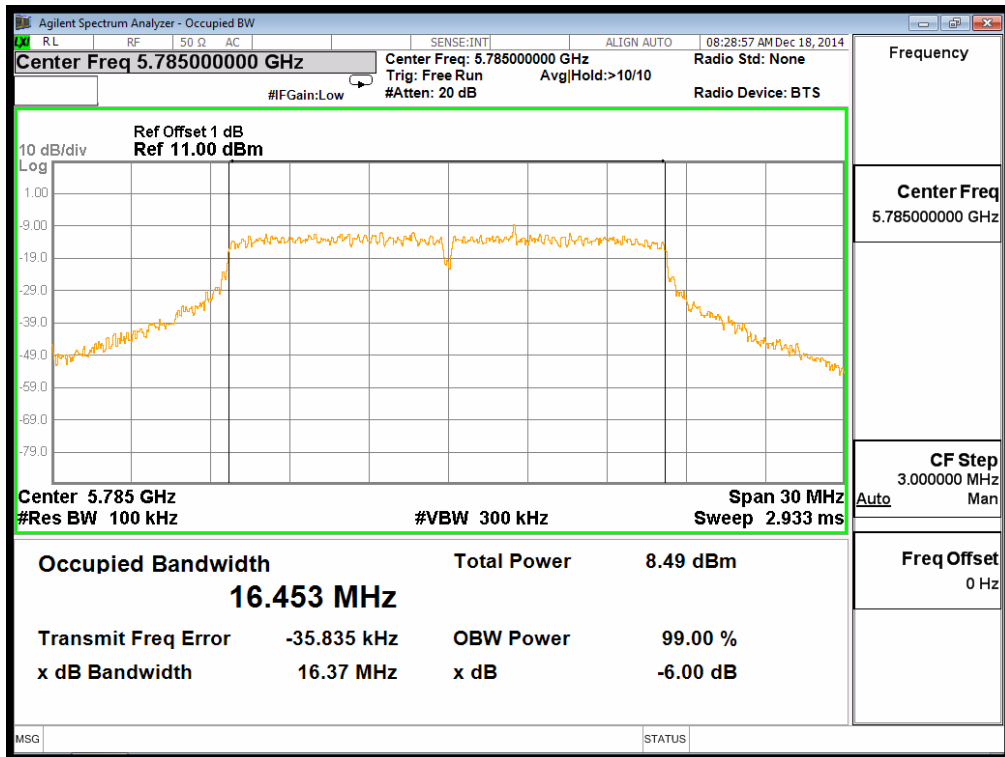

Channel 165 (5825MHz)

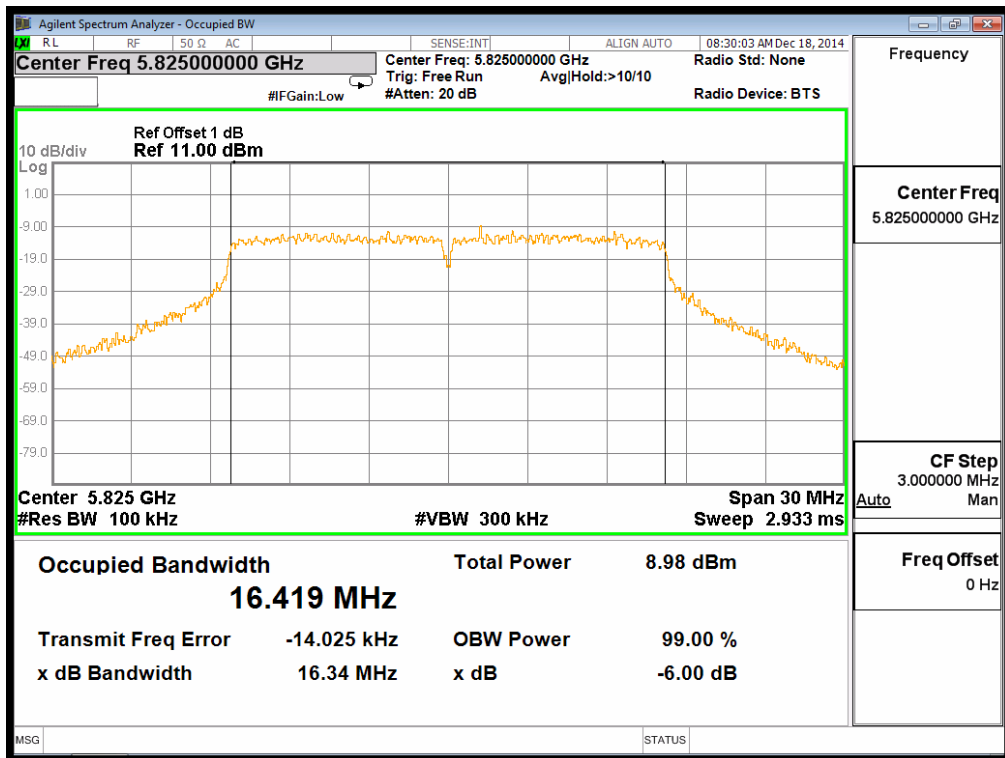



Test Item	Occupied Bandwidth
Test Mode	Transmit by 802.11n HT-20 Chain 0
Test Date	2014-12-10

Channel No.	Frequency (MHz)	Measurement Level (kHz)	Required Limit (kHz)	Result
149	5745	17624	500	Pass
157	5785	17606	500	Pass
165	5825	17599	500	Pass

Channel 149(5745MHz)

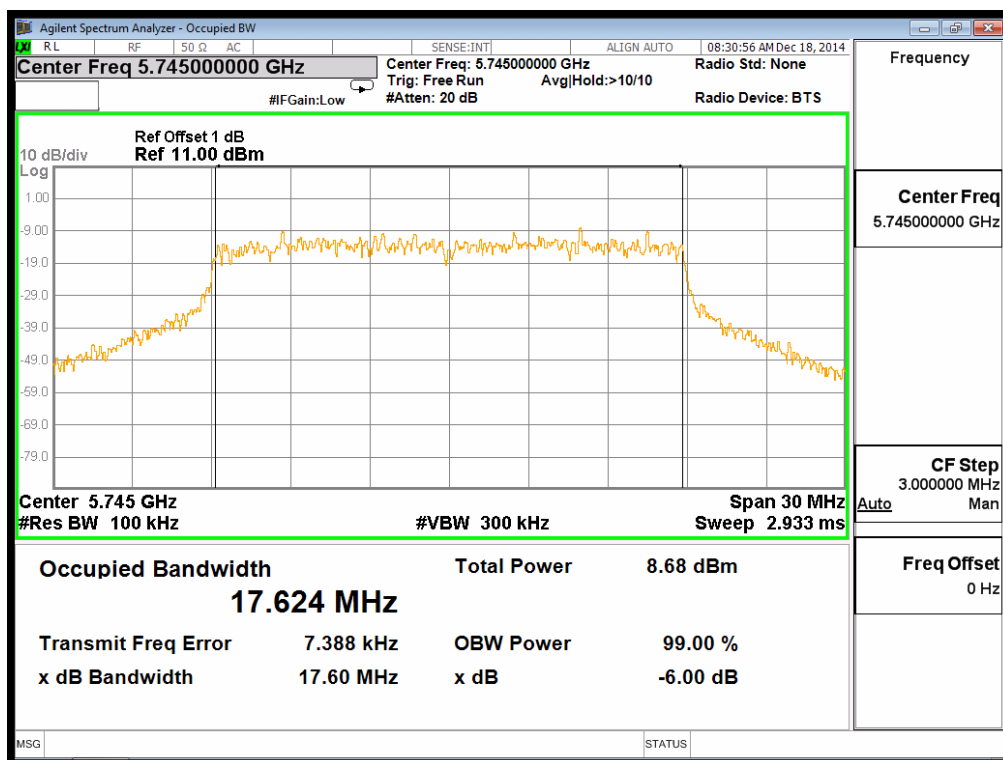



Channel 157 (5785MHz)

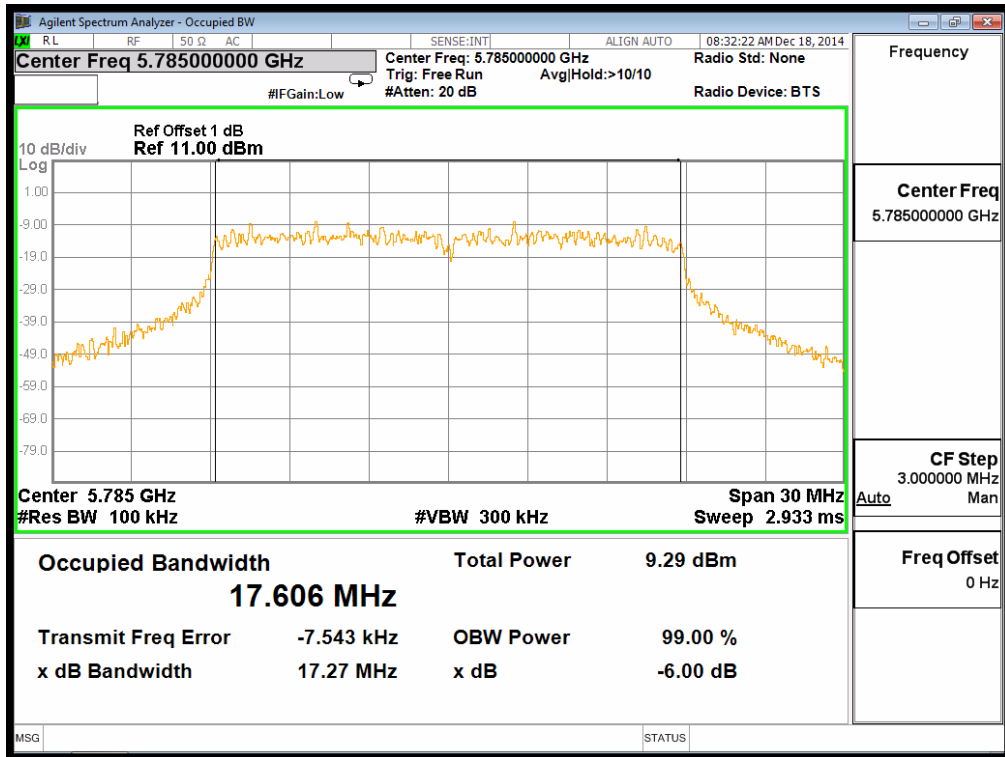

Channel 165 (5825MHz)

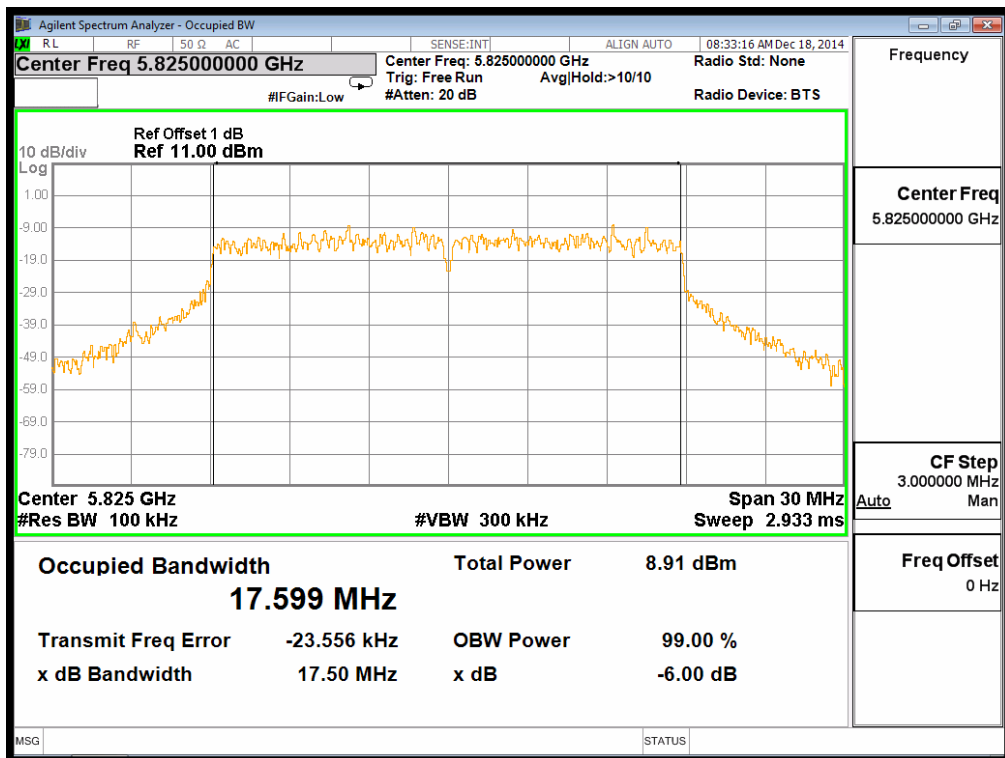



Test Item	Occupied Bandwidth
Test Mode	Transmit by 802.11n HT-20 Chain 1
Test Date	2014-12-10

Channel No.	Frequency (MHz)	Measurement Level (kHz)	Required Limit (kHz)	Result
149	5745	17605	500	Pass
157	5785	17603	500	Pass
165	5825	17585	500	Pass

Channel 149 (5745MHz)

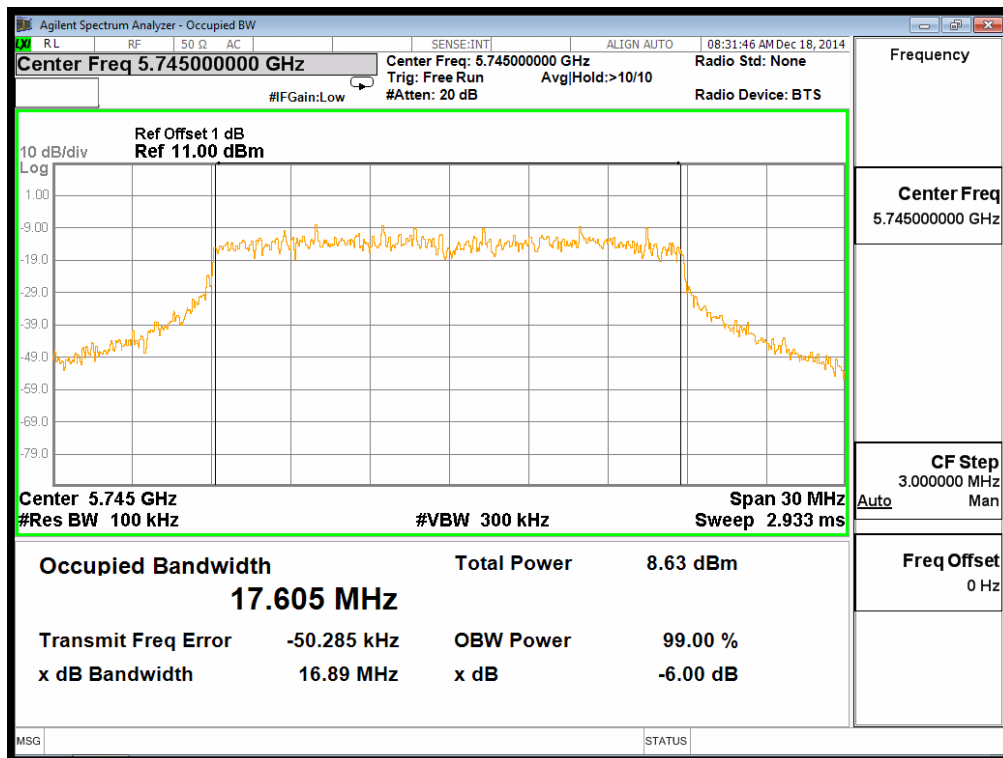



Channel 157 (5785MHz)

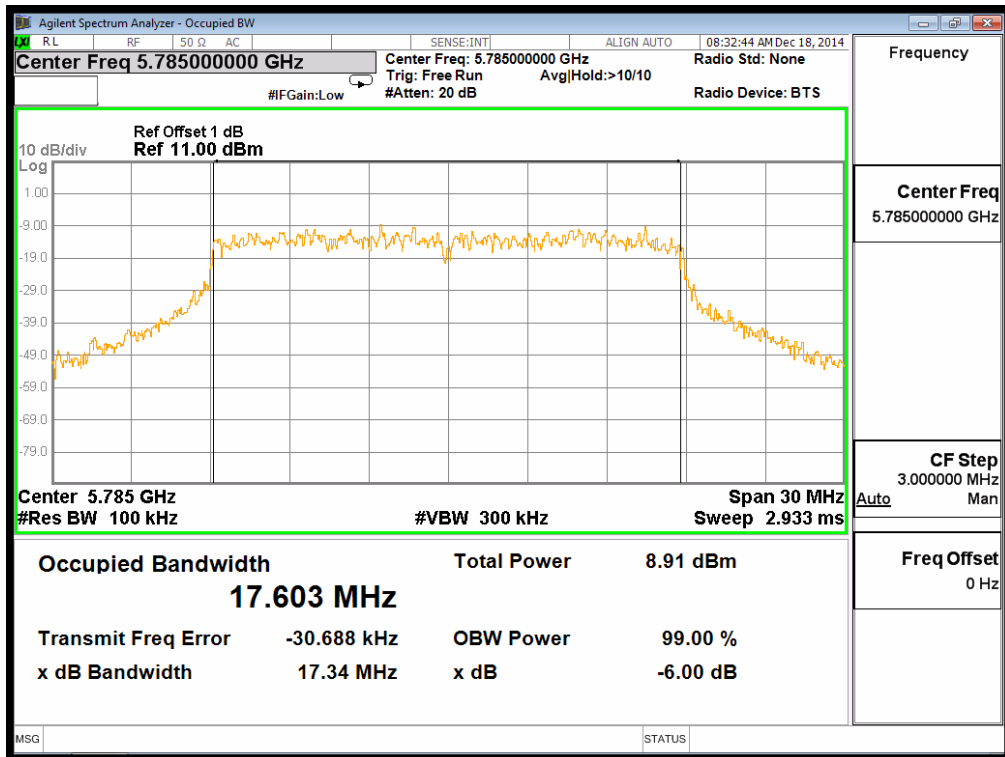

Channel 165 (5825MHz)

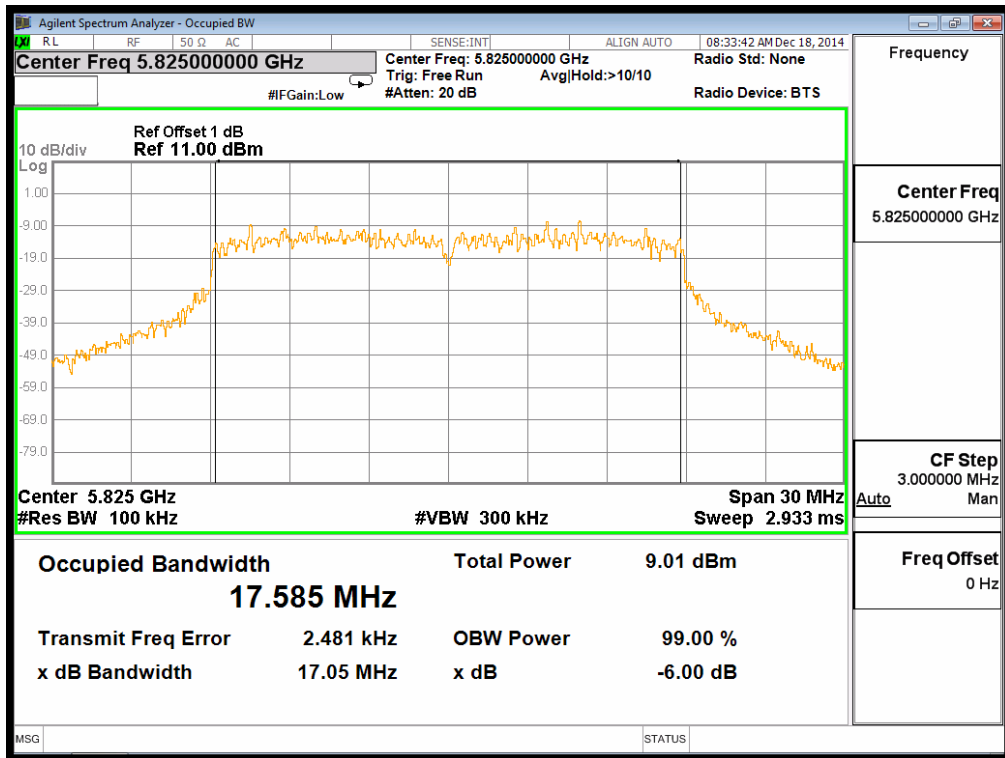



Test Item	Occupied Bandwidth
Test Mode	Transmit by 802.11n HT-40 Chain 0
Test Date	2014-12-10

Channel No.	Frequency (MHz)	Measurement Level (kHz)	Required Limit (kHz)	Result
151	5755	36167	500	Pass
159	5795	36052	500	Pass

Channel 151 (5755MHz)

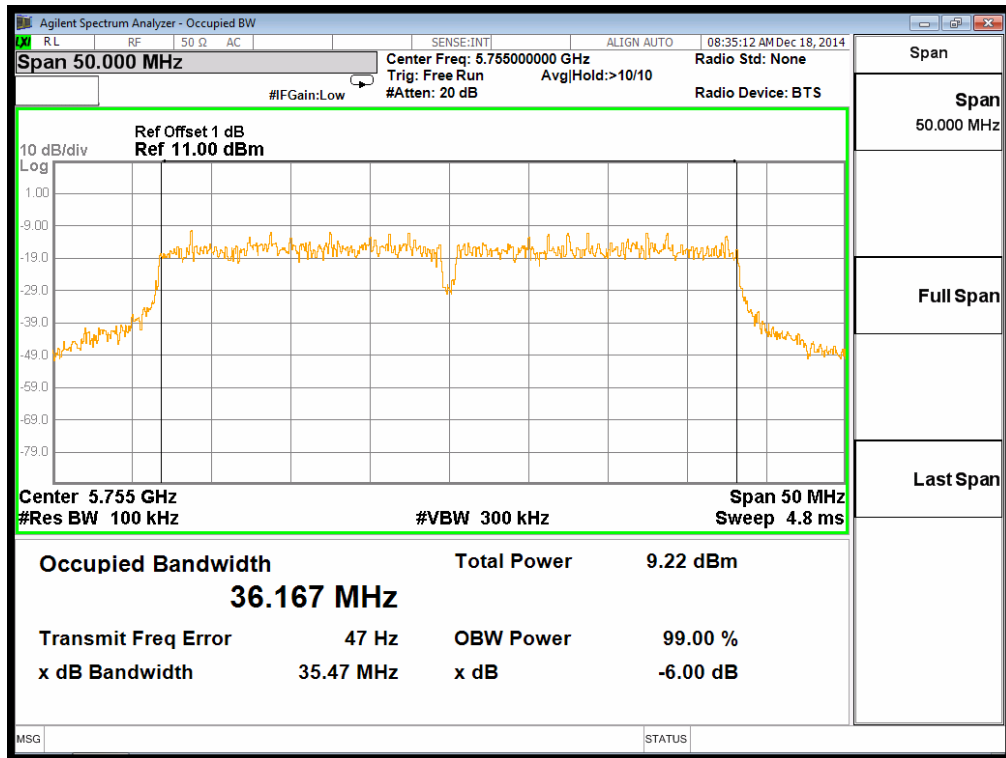





Channel 159 (2437MHz)

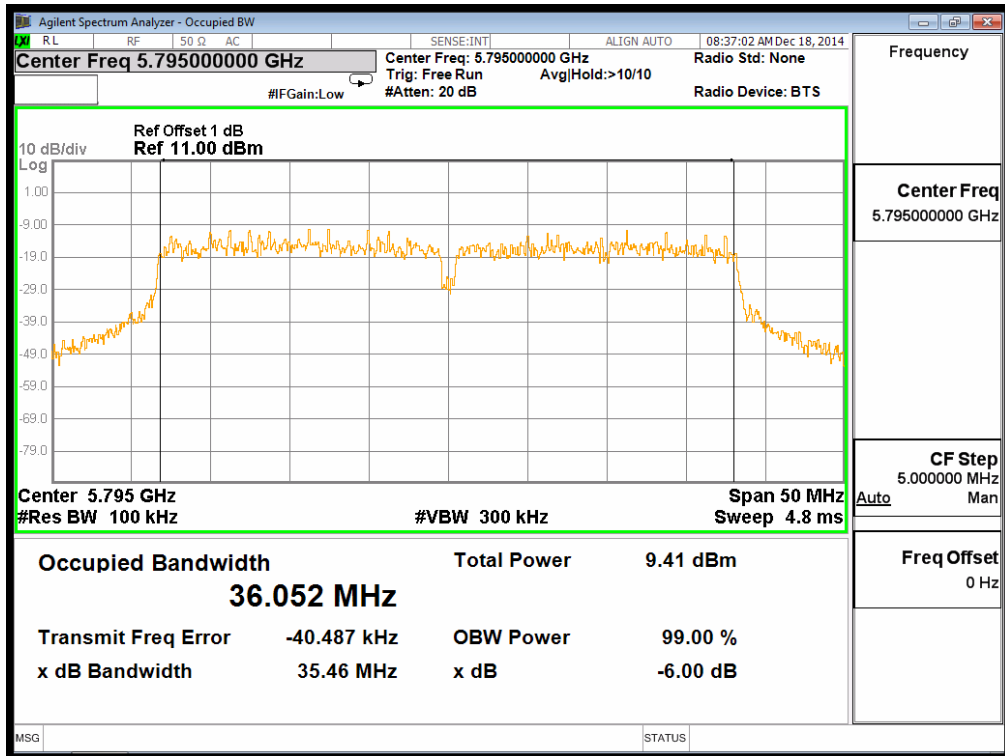



Test Item	Occupied Bandwidth
Test Mode	Transmit by 802.11n HT-40 Chain 1
Test Date	2014-12-10

Channel No.	Frequency (MHz)	Measurement Level (kHz)	Required Limit (kHz)	Result
151	5755	35948	500	Pass
159	5795	36174	500	Pass

Channel 151 (5755MHz)

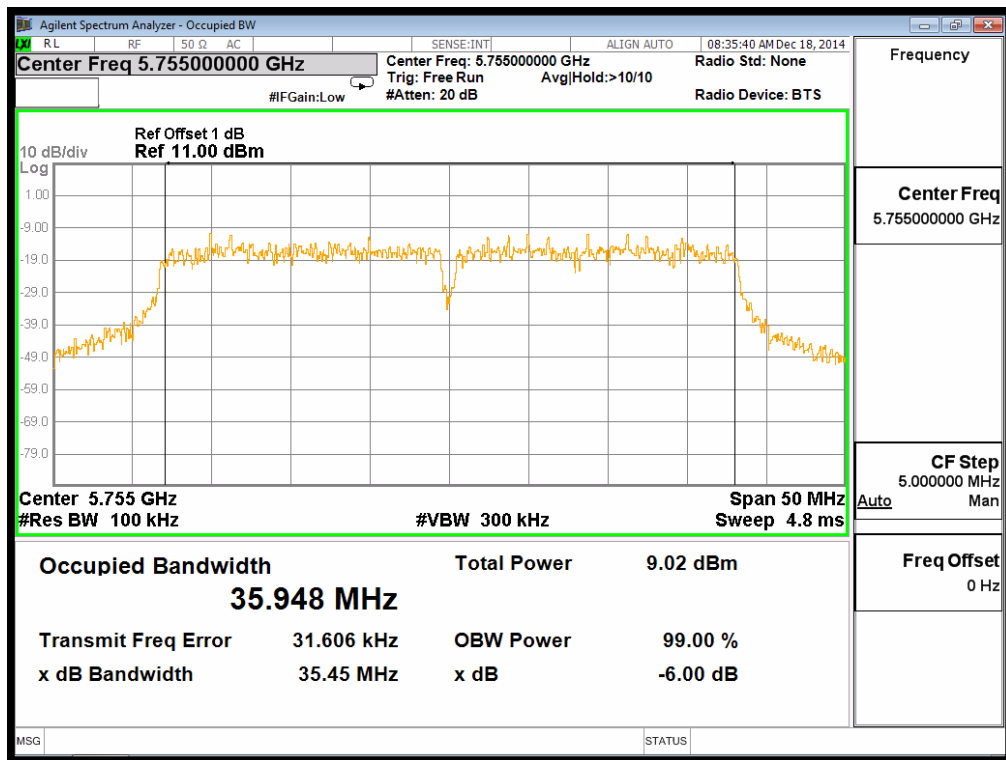



Channel 159 (2437MHz)

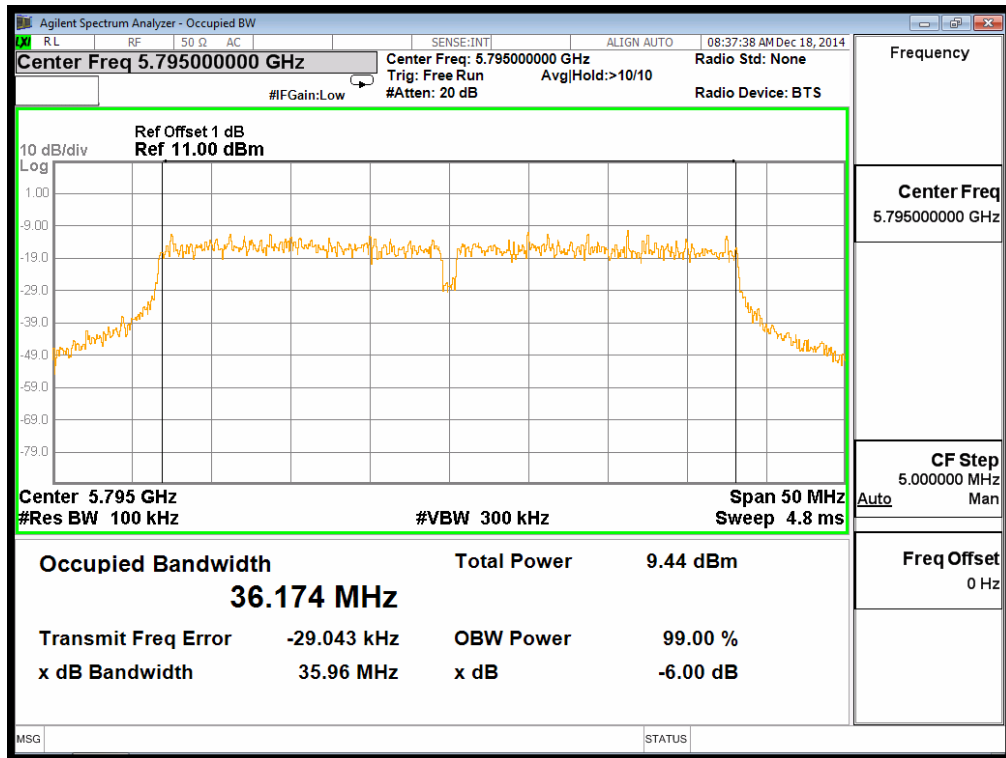



## 8. Maximum Peak Output Power

### 8.1 Test Limit

The Maximum Peak Output Power Measurement is 30dBm.

### 8.2 Test Procedures

The antenna port (RF output) of the EUT was connected to the input (RF input) of a power meter. Power was read directly from the meter and cable loss connection was added to the reading to obtain power at the EUT antenna terminal. The EUT Output Power was set to maximum to produce the worse case test result.

### 8.3 Test Setup Layout

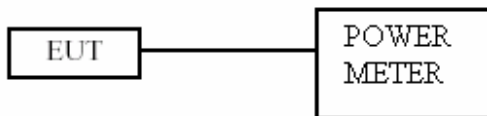



8.4 Test Result and Data

Test Item	Maximum Peak Output Power
Test Mode	Transmit by 802.11b
Duty cycle	99%
Test Date	2014-12-15

Channel No.	Frequency (MHz)	Measurement (dBm)			Required Limit (dBm)	Result
		Chain 0	Chain 1	Total Power		
01	2412	19.14	19.24	22.20	30	Pass
06	2437	19.40	19.27	22.35	30	Pass
11	2462	19.60	19.38	22.50	30	Pass

Test Item	Maximum Peak Output Power
Test Mode	Transmit by 802.11g
Duty cycle	99%
Test Date	2014-12-15

Channel No.	Frequency (MHz)	Measurement (dBm)			Required Limit (dBm)	Result
		Chain 0	Chain 1	Total Power		
01	2412	17.23	17.17	20.21	30	Pass
06	2437	17.34	17.25	20.31	30	Pass
11	2462	17.53	17.33	20.44	30	Pass



Test Item	Maximum Peak Output Power
Test Mode	Transmit by 802.11n (HT20)
Duty cycle	99%
Test Date	2014-12-10

Channel No.	Frequency (MHz)	Measurement (dBm)			Required Limit (dBm)	Result
		Chain 0	Chain 1	Total Power		
01	2412	17.18	17.28	20.24	30	Pass
06	2437	17.22	17.31	20.28	30	Pass
11	2462	17.57	17.62	20.61	30	Pass

Test Item	Maximum Peak Output Power
Test Mode	Transmit by 802.11n (HT40)
Duty cycle	99%
Test Date	2014-12-10

Channel No.	Frequency (MHz)	Measurement (dBm)			Required Limit (dBm)	Result
		Chain 0	Chain 1	Total Power		
01	2422	17.39	17.37	20.39	30	Pass
06	2437	17.42	17.33	20.39	30	Pass
11	2452	17.66	17.31	20.50	30	Pass



Test Item	Maximum Peak Output Power
Test Mode	Transmit by 802.11a
Duty cycle	99%
Test Date	2014-12-10

Channel No.	Frequency (MHz)	Measurement (dBm)			Required Limit (dBm)	Result
		Chain 0	Chain 1	Total Power		
149	5745	17.65	17.56	20.62	30	Pass
157	5785	17.54	17.59	20.58	30	Pass
165	5825	17.23	17.67	20.47	30	Pass

Test Item	Maximum Peak Output Power
Test Mode	Transmit by 802.11an (HT20)
Duty cycle	99%
Test Date	2014-12-10

Channel No.	Frequency (MHz)	Measurement (dBm)			Required Limit (dBm)	Result
		Chain 0	Chain 1	Total Power		
149	5745	17.11	17.44	20.29	30	Pass
157	5785	17.03	17.29	20.17	30	Pass
165	5825	16.63	17.21	19.94	30	Pass



Test Item	Maximum Peak Output Power
Test Mode	Transmit by 802.11n (HT40)
Duty cycle	99%
Test Date	2014-12-10

Channel No.	Frequency (MHz)	Measurement (dBm)			Required Limit (dBm)	Result
		Chain 0	Chain 1	Total Power		
151	5755	17.30	17.66	20.49	30	Pass
159	5795	17.11	17.37	20.25	30	Pass





## 9. Power Spectral Density

### 9.1 Test Limit

The Maximum of Power Spectral Density Measurement is 8dBm.

### 9.2 Test Procedures

- a. The transmitter output was connected to spectrum analyzer.
- b. The spectrum analyzer's resolution bandwidth were set at 3KHz RBW and 30KHz VBW as that of the fundamental frequency. Set the sweep time=auto couple.
- c. The power spectral density was measured and recorded.

### 9.3 Test Setup Layout

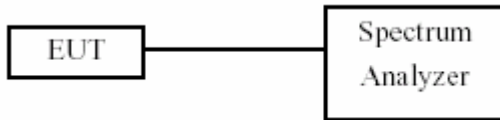



9.4 Test Result and Data

Test Date : Dec. 15, 2014 Temperature : 20°C
Atmospheric pressure : 1020 hPa Humidity : 50%

Table with 5 columns: Modulation Type, Frequency (MHz), Chain 0, Chain 1, Summation. Rows include IEEE 802.11b, IEEE 802.11g, IEEE 802.11n HT20, and IEEE 802.11n HT40 at various frequencies.

Test Date : Dec. 15, 2014 Temperature : 20°C
Atmospheric pressure : 1020 hPa Humidity : 50%

Table with 5 columns: Modulation Type, Frequency (MHz), Chain 0, Chain 1, Summation. Rows include IEEE 802.11a (6Mbps), IEEE 802.11an HT20 (6.5Mbps), and IEEE 802.11an HT40 (6.5Mbps) at various frequencies.



Modulation Type: 802.11b, CH01 Chain 0



Modulation Type: 802.11b, CH01 Chain 1



Modulation Type: 802.11b, CH06 Chain 0



Modulation Type: 802.11b, CH06 Chain 1



Modulation Type: 802.11b, CH11 Chain 0



Modulation Type: 802.11b, CH11 Chain 1





Modulation Type: 802.11g, CH01 Chain 0

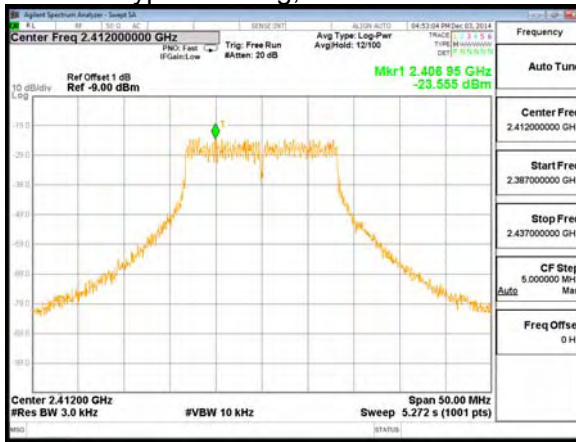

Modulation Type: 802.11g, CH01 Chain 1

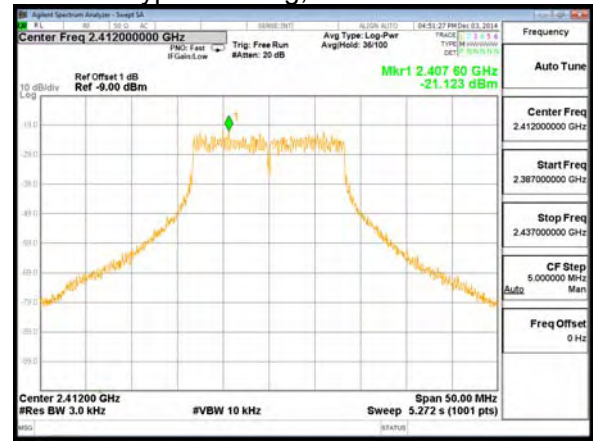

Modulation Type: 802.11g, CH06 Chain 0

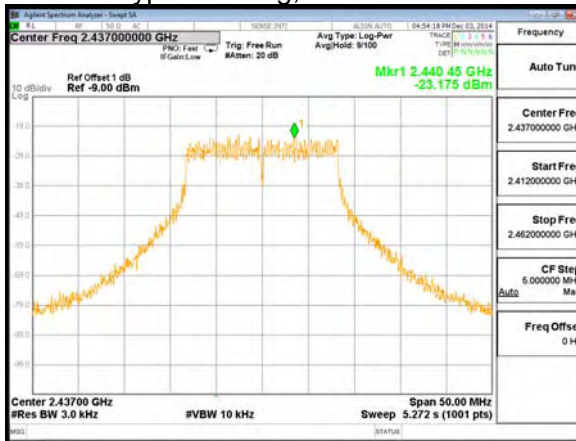

Modulation Type: 802.11g, CH06 Chain 1



Modulation Type: 802.11g, CH11 Chain 0

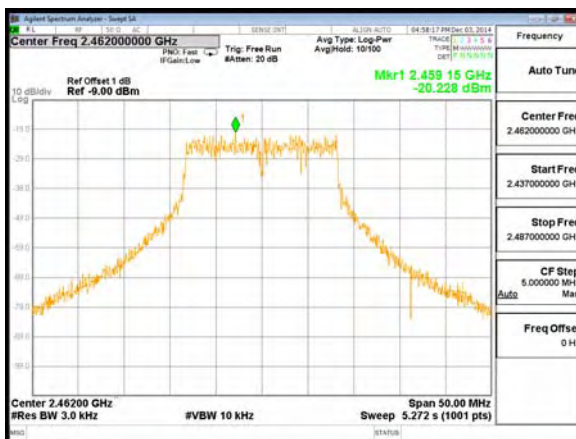

Modulation Type: 802.11g, CH11 Chain 1

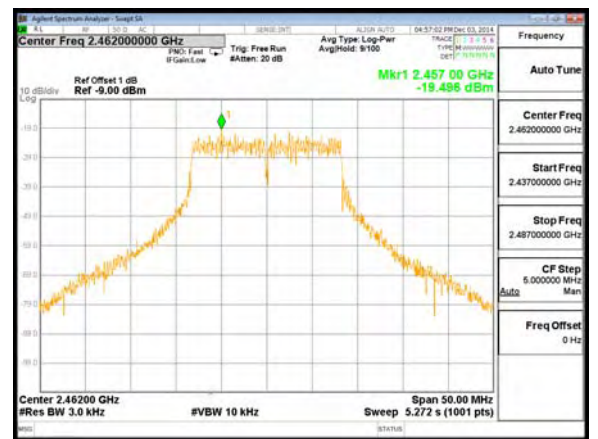



Modulation Type: 802.11n HT20, CH01 Chain 0

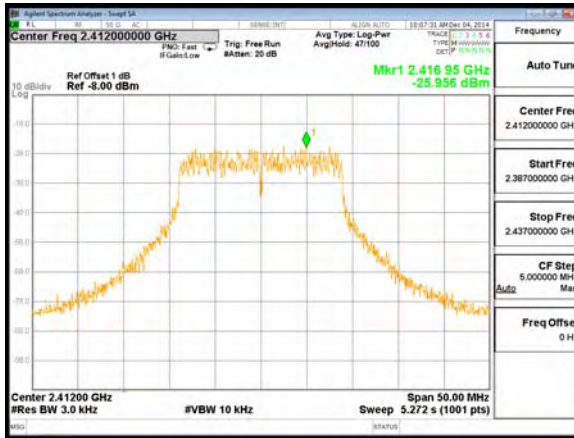

Modulation Type: 802.11n HT20, CH01 Chain 1

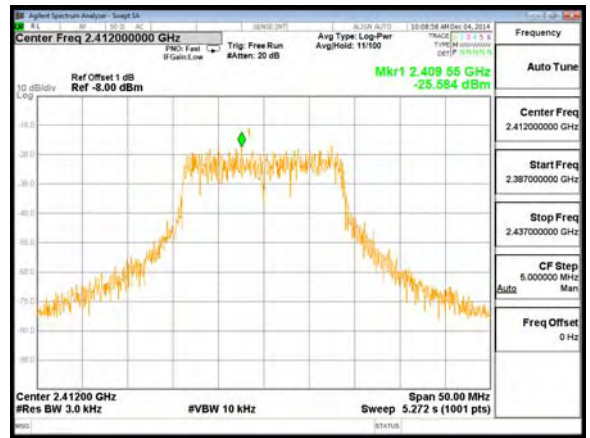

Modulation Type: 802.11n HT20, CH06 Chain 0

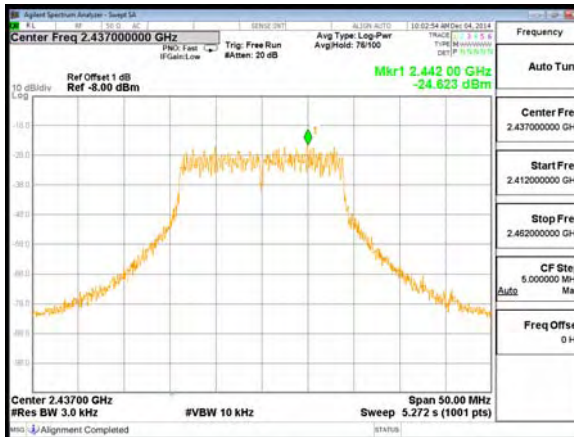

Modulation Type: 802.11n HT20, CH06 Chain 1

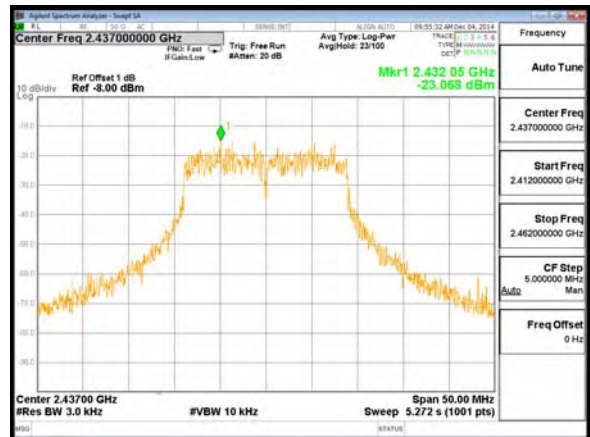

Modulation Type: 802.11n HT20, CH06 Chain 0

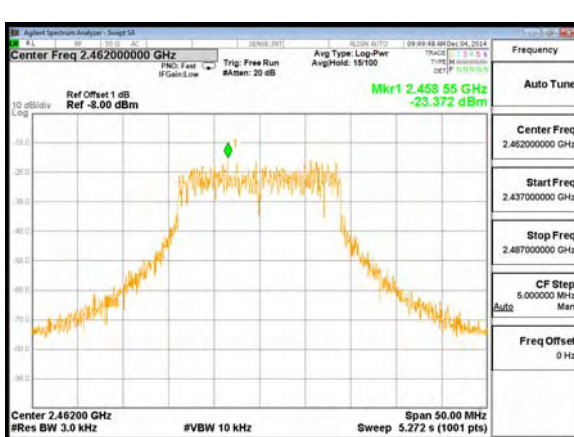

Modulation Type: 802.11n HT20, CH06 Chain 1

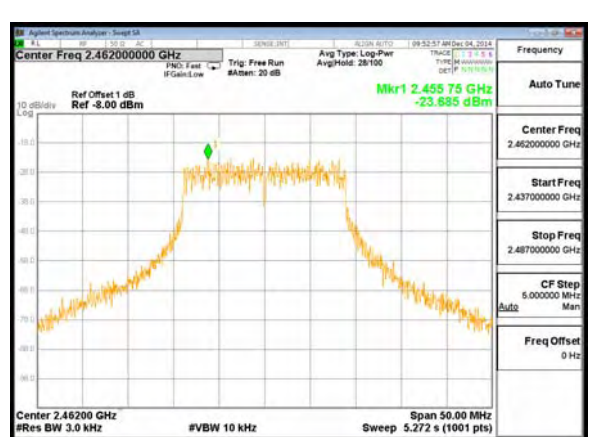



Modulation Type: 802.11n HT40, CH03 Chain 0

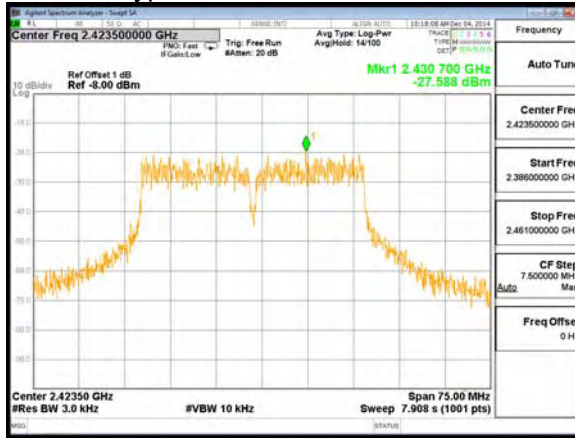

Modulation Type: 802.11n HT40, CH03 Chain 1

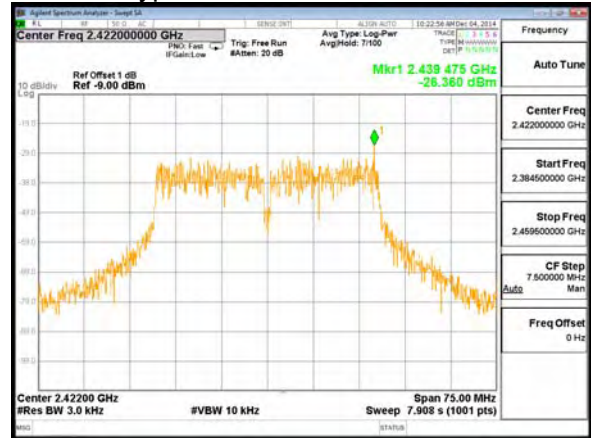

Modulation Type: 802.11n HT40, CH06 Chain 0

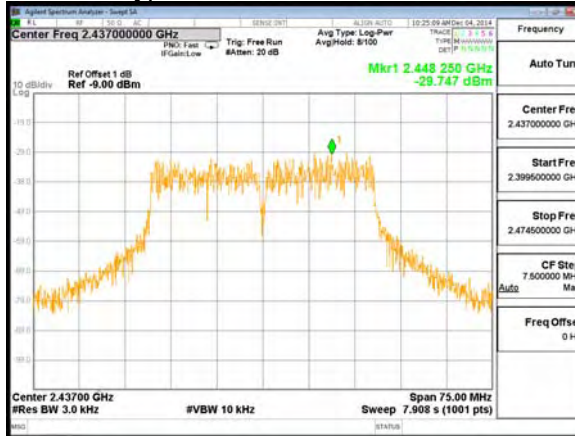

Modulation Type: 802.11n HT40, CH06 Chain 1

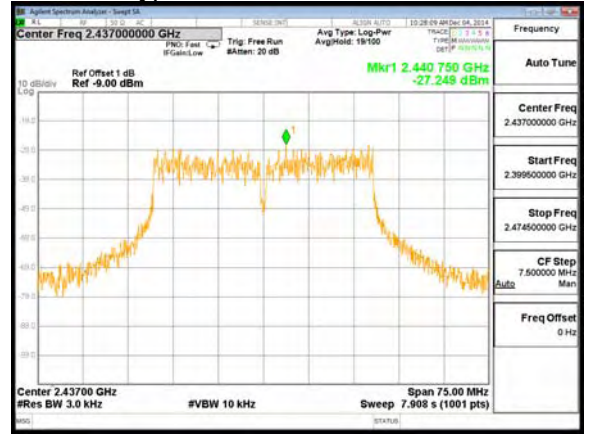

Modulation Type: 802.11n HT40, CH09 Chain 0

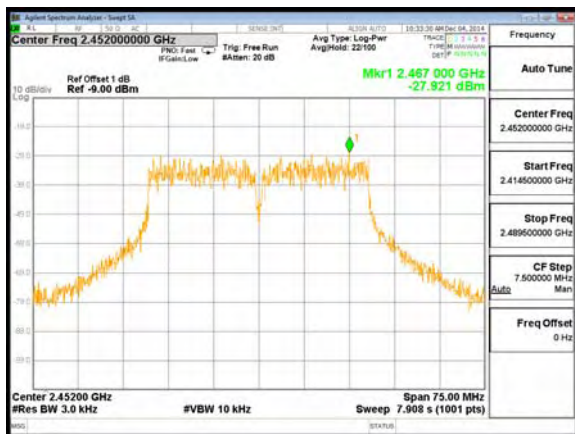

Modulation Type: 802.11n HT40, CH09 Chain 1

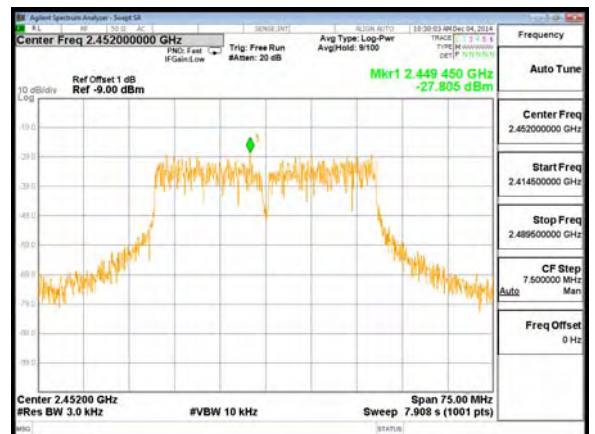



Modulation Type: 802.11a, CH149 Chain 0

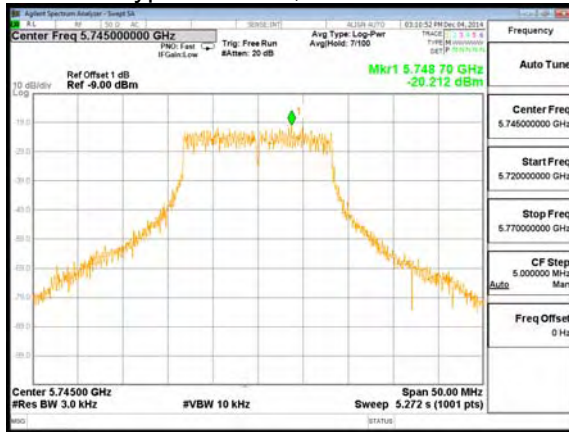

Modulation Type: 802.11a, CH149 Chain 1

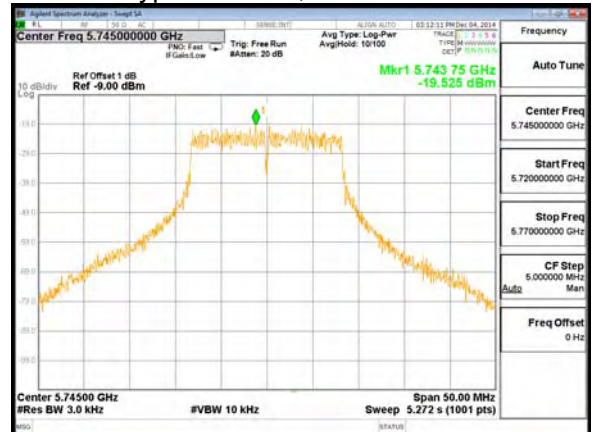

Modulation Type: 802.11a, CH157 Chain 0

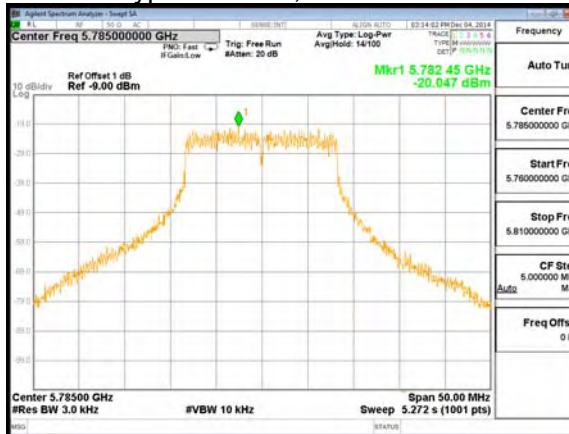

Modulation Type: 802.11a, CH157 Chain 1

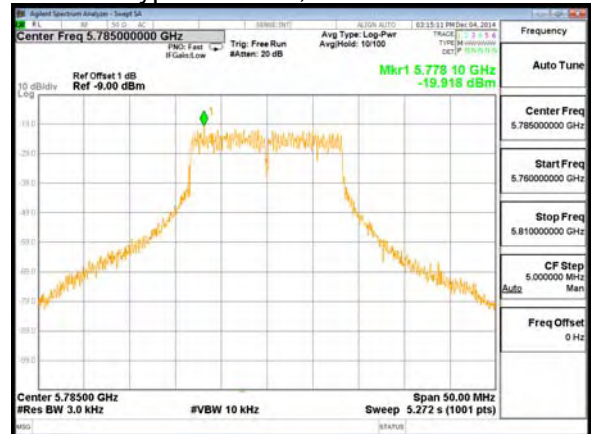

Modulation Type: 802.11a, CH165 Chain 0

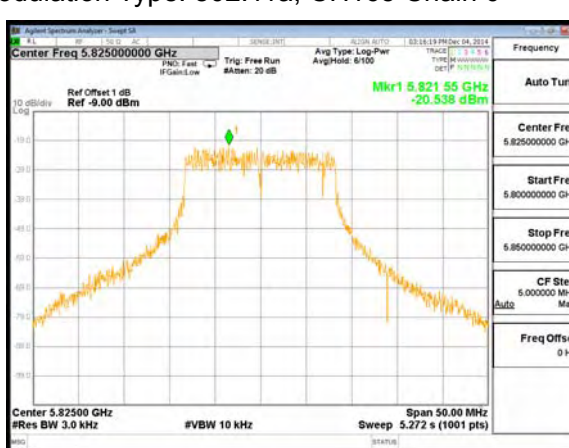

Modulation Type: 802.11a, CH165 Chain 1

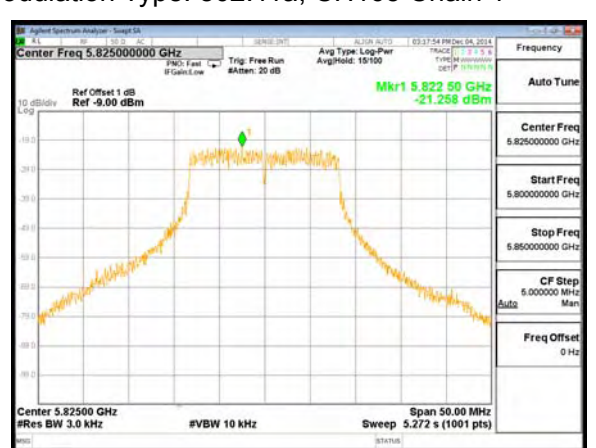



Modulation Type: 802.11n HT20,CH149 Chain 0

Modulation Type: 802.11n HT20, CH149 Chain 1

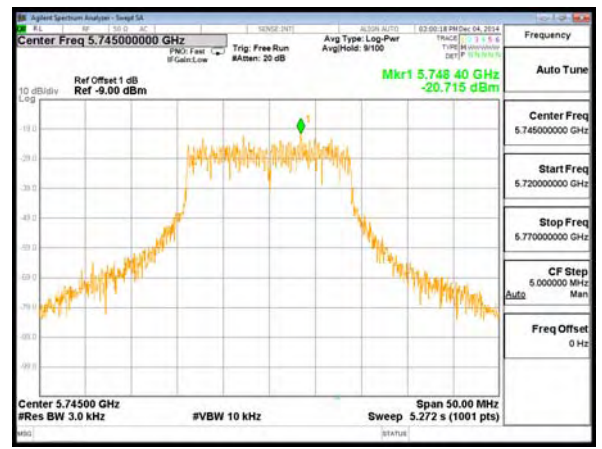
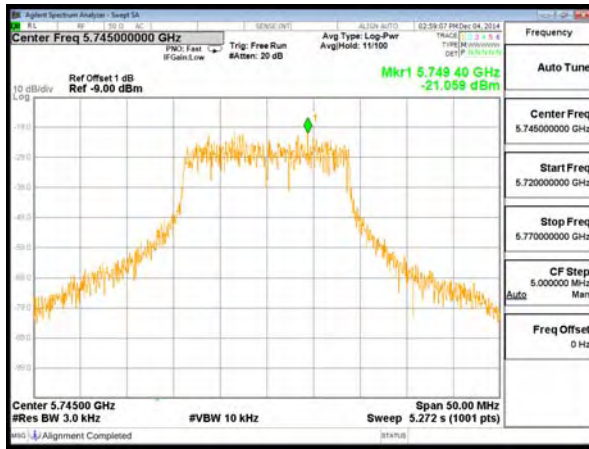

Modulation Type: 802.11n HT20 CH157 Chain 0

Modulation Type: 802.11n HT20 CH157 Chain 1

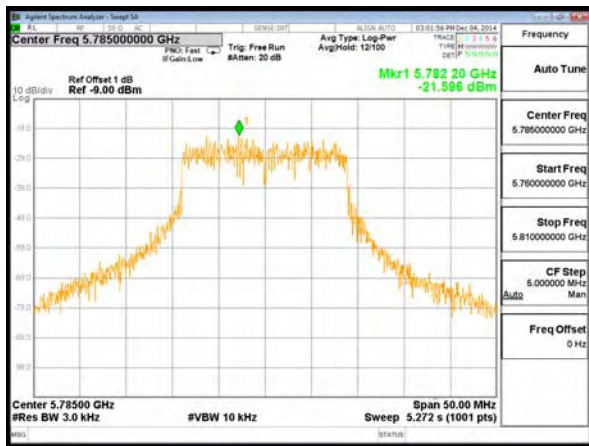

Modulation Type: 802.11n HT20,CH165 Chain 0

Modulation Type: 802.11n HT20, CH165 Chain 1

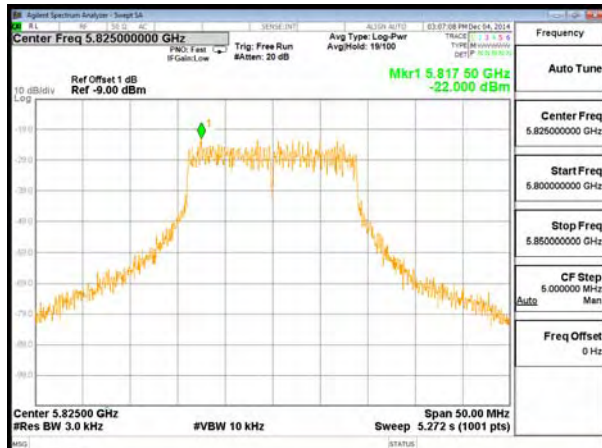
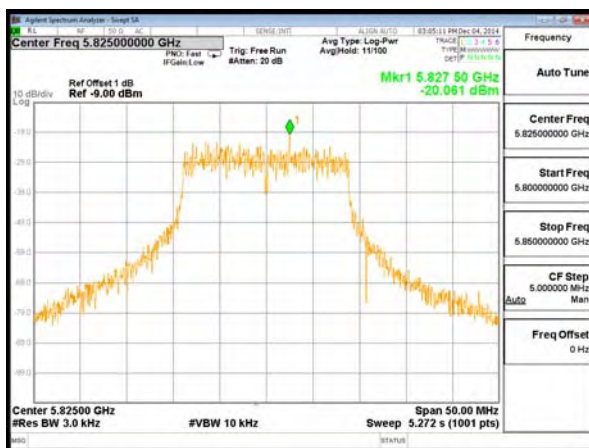





Modulation Type: 802.11n HT40,CH151 Chain 0

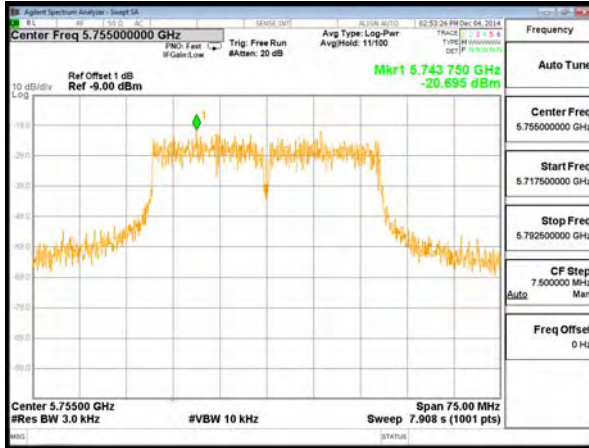

Modulation Type: 802.11n HT40,CH151 Chain 1

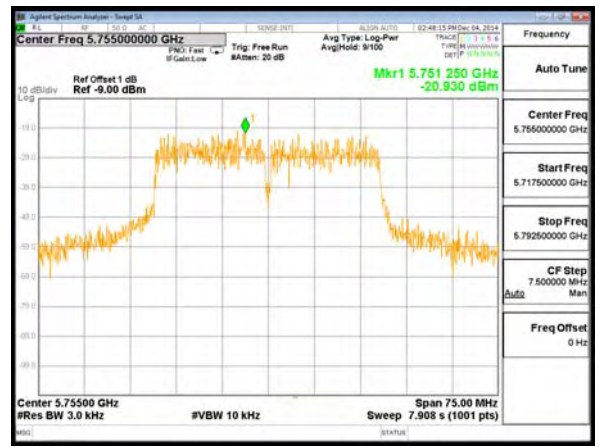

Modulation Type: 802.11n HT40,CH159 Chain 0

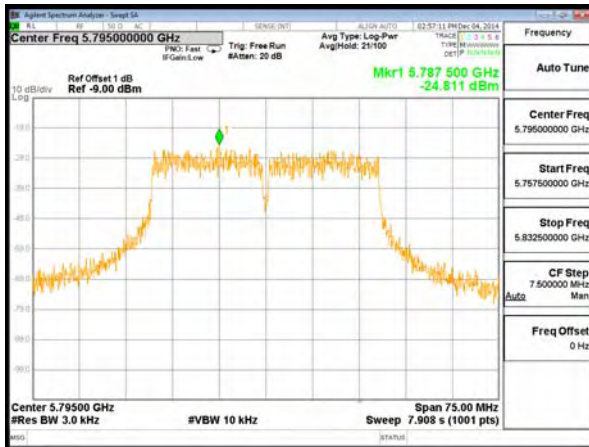

Modulation Type: 802.11n HT40,CH159 Chain 1

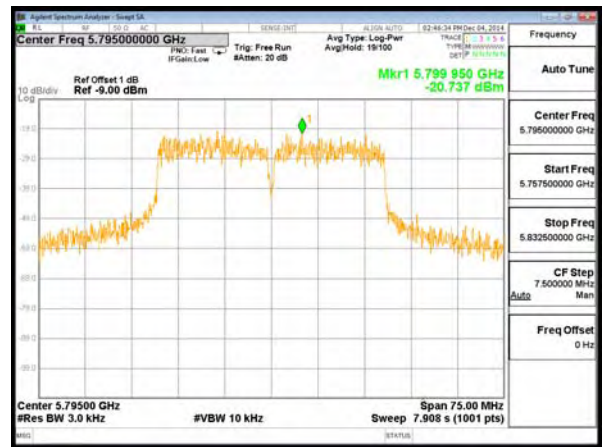



## 10. Band Edges Measurement

### 10.1 Test Limit

Below -20dB of the highest emission level of operating band (In 100 kHz Resolution Bandwidth)

### 10.2 Test Procedure

- a. The transmitter output was connected to the spectrum analyzer via a low lose cable.
- b. Set RBW of spectrum analyzer to 100 KHz and VBW of spectrum analyzer to 300 KHz with convenient frequency span including 100 KHz bandwidth from band edge.
- c. Peak conducted output power measured within any 100 kHz outside the authorized frequency band shall be attenuated by at least 20dB relative to the maximum measured in-band peak PSD level.
- d. The band edges was measured and recorded.

### 10.3 Test Setup Layout

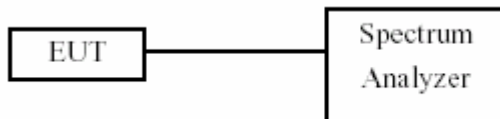



10.4 Test Result and Data

Test Date : Dec. 15, 2014 Temperature : 20°C
Atmospheric pressure : 1020 hPa Humidity : 50%

Table with 5 columns: Modulation Type, Channel, Frequency (MHz), Maximum value in frequency (MHz), Maximum value (dBm). Rows include IEEE 802.11b, IEEE 802.11g, IEEE 802.11n HT20, and IEEE 802.11n HT40.

Test Date : Dec. 15 2014 Temperature : 20°C
Atmospheric pressure : 1020 hPa Humidity : 50%

Table with 5 columns: Modulation Type, Channel, Frequency (MHz), Maximum value in frequency (MHz), Maximum value (dBm). Rows include IEEE 802.11a, IEEE 802.11n HT20, and IEEE 802.11n HT40.



Modulation Type: 802.11b, CH01



Modulation Type: 802.11b, CH11

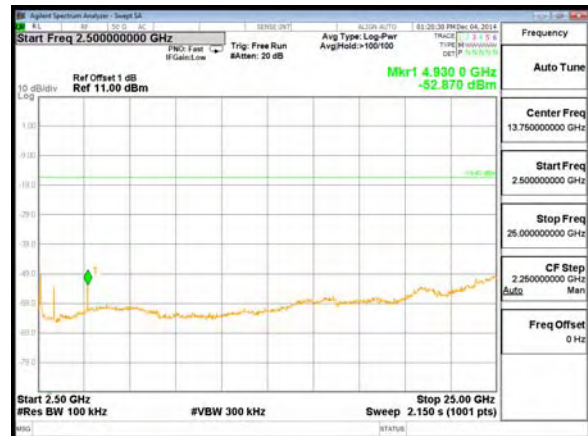

Modulation Type: 802.11g, CH01

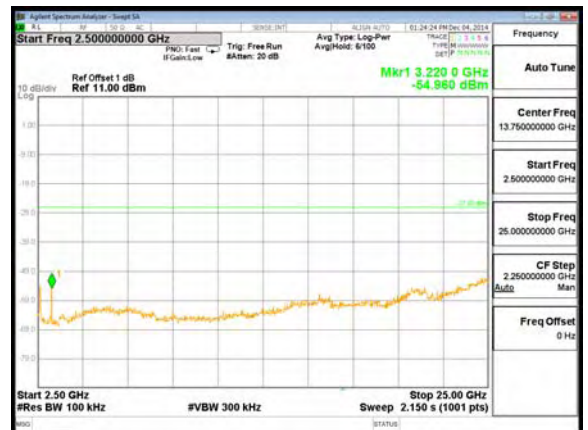
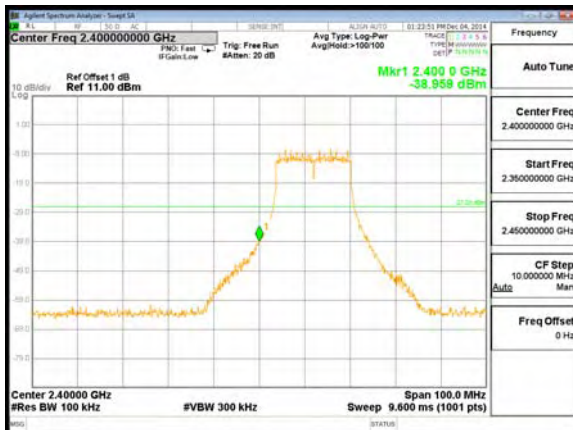



Modulation Type: 802.11g, CH11

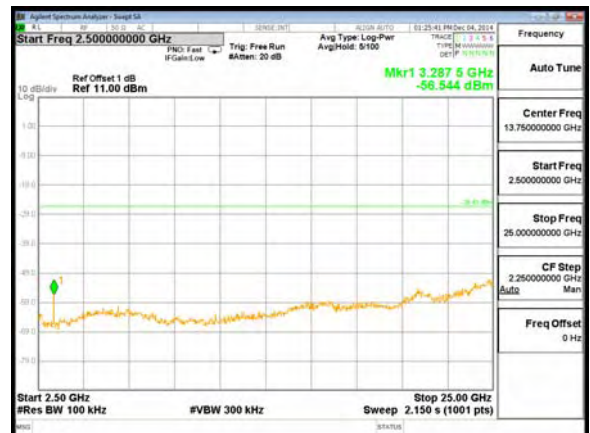

Modulation Type: 802.11n HT20, CH01

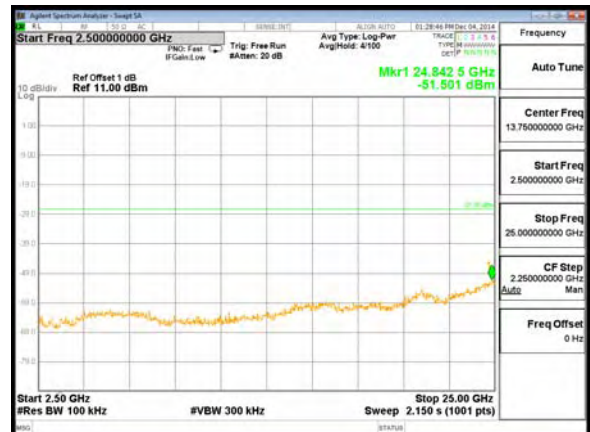
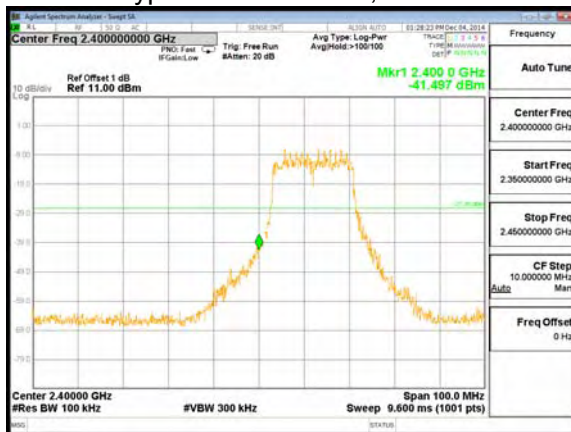

Modulation Type: 802.11n HT20, CH11

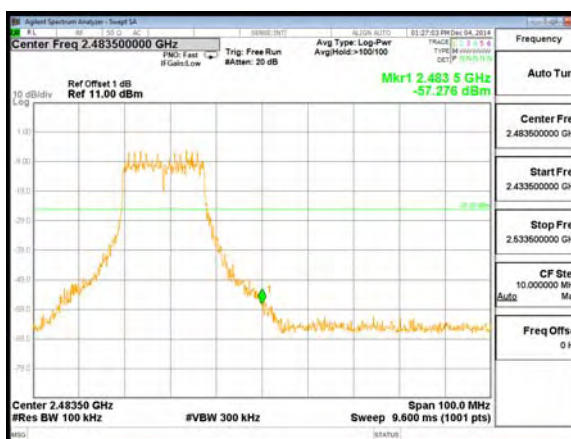



Modulation Type: 802.11n HT40, CH03

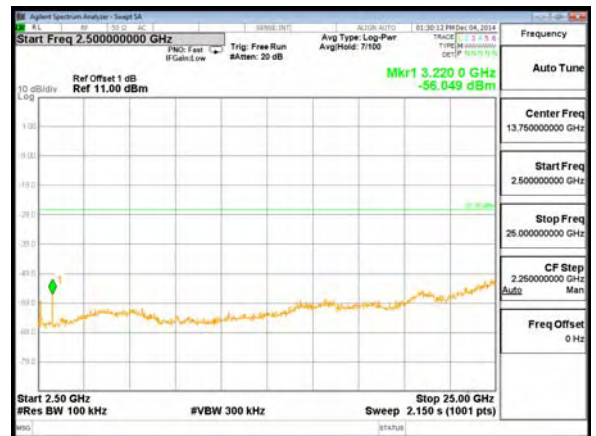
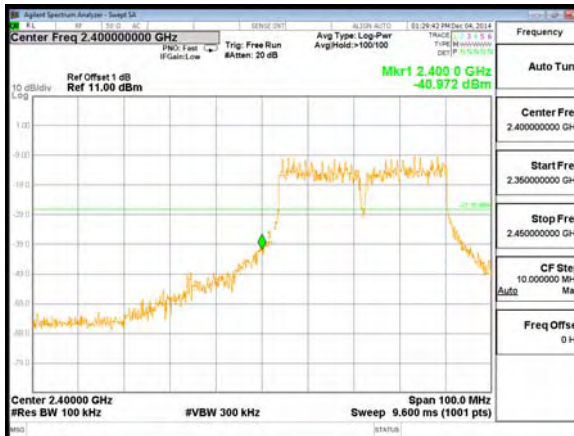

Modulation Type: 802.11n HT40, CH09

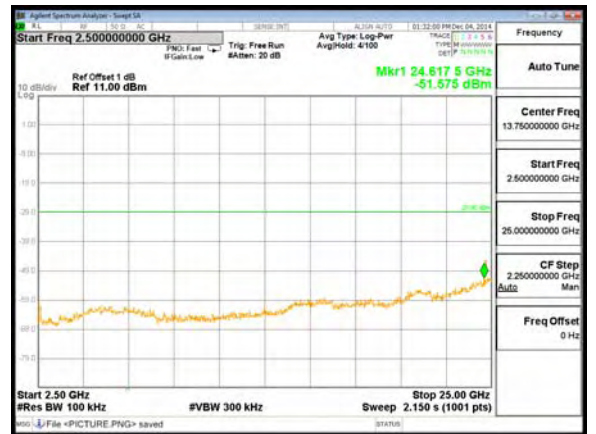
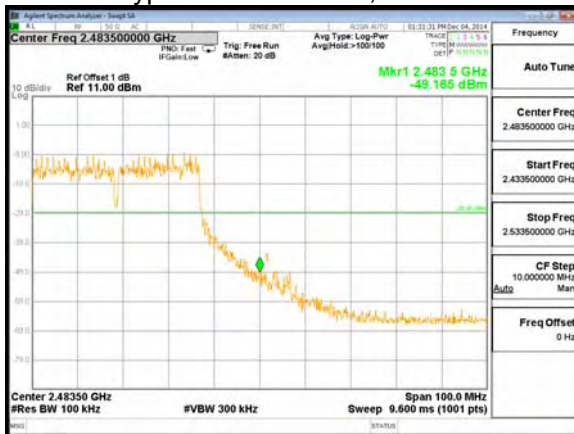

Modulation Type: 802.11a, CH149

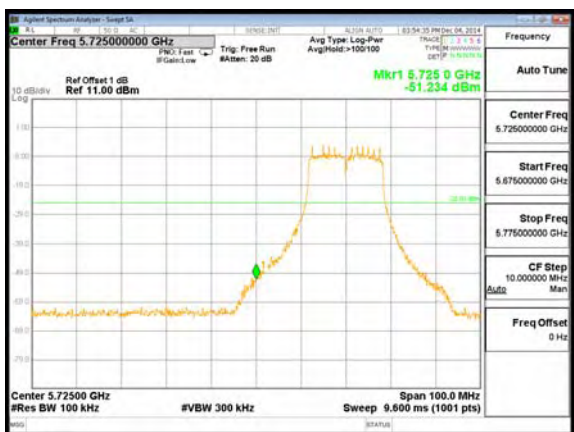



Modulation Type: 802.11a, CH165

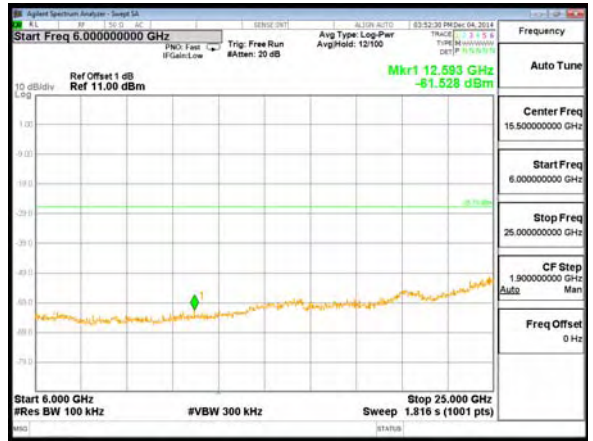

Modulation Type: 802.11n HT20, CH149

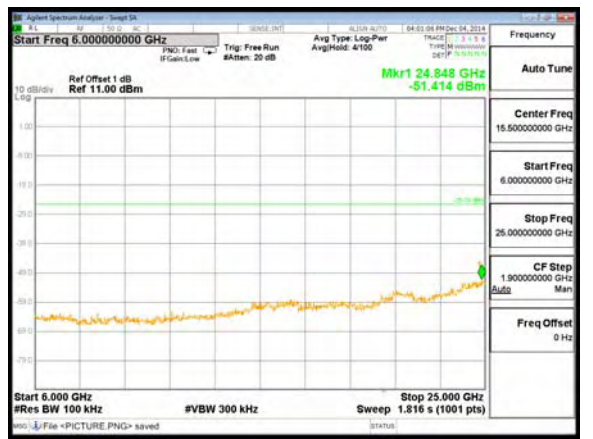
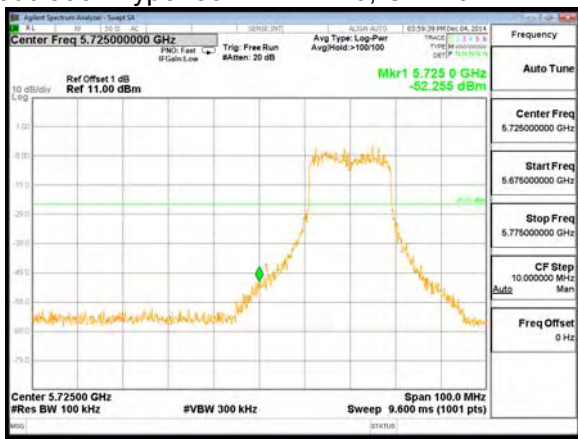

Modulation Type: 802.11n HT20, CH165

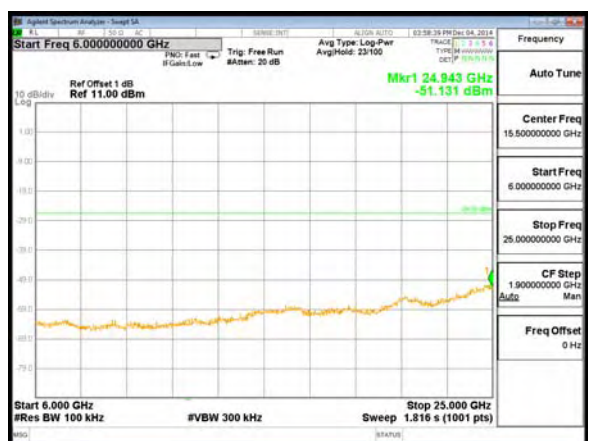
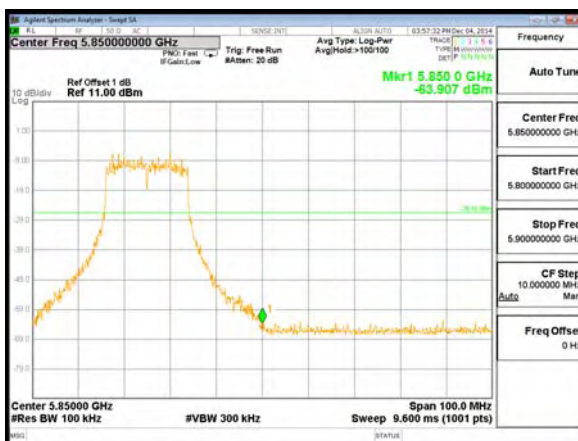



Modulation Type: 802.11n HT40, CH151

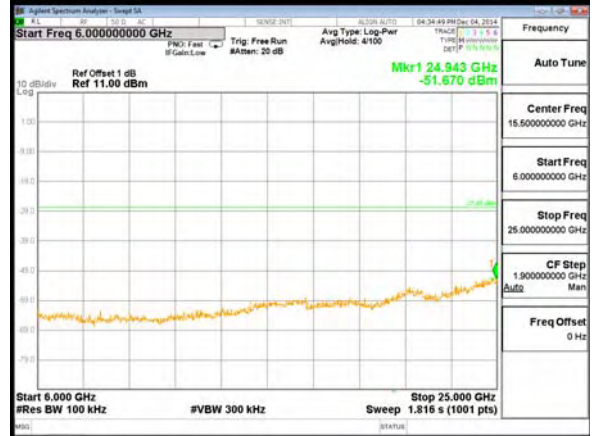
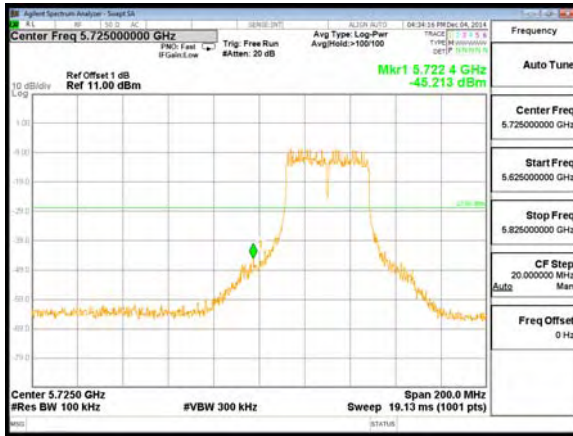

Modulation Type: 802.11n HT40, CH159

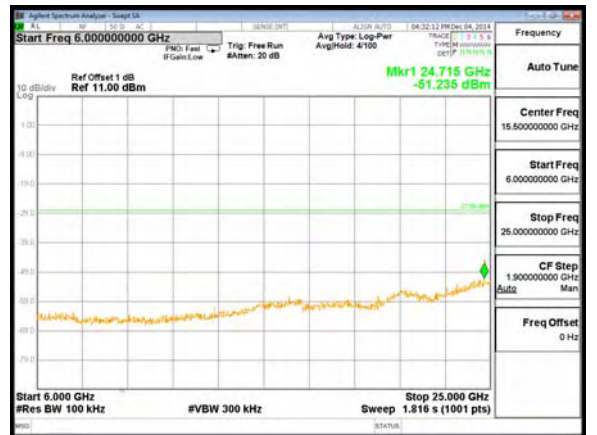
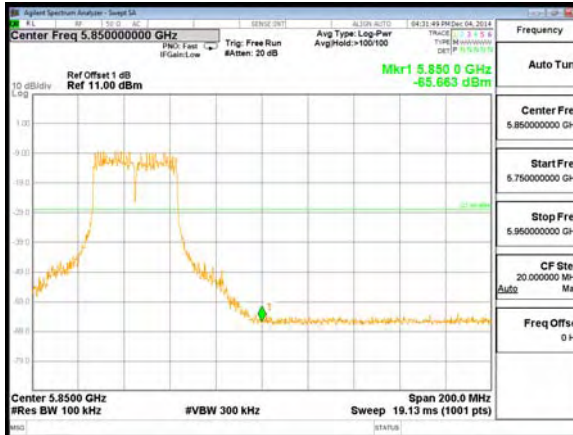



**10.5 Restrict Band Emission Measurement Data**

Test Date: Dec. 05, 2014

Temperature: 24 °C

Atmospheric pressure: 1027 hPa

Humidity: 52 %

Modulation Standard: IEEE 802.11b

Channel 1						Fundamental Frequency: 2412 MHz				
Frequency (MHz)	Ant-Pol H/V	Meter Reading (dBuV)	Corrected Factor (dB)	Result (dBuV/m)	Remark	Limit (dBuV/m)		Margin (dB)	Table Deg.	Ant High (m)
						Peak	Ave			
2384.868	V	53.09	-1.20	51.89	Peak	74	54	-22.11	168	1.02
---	V	---	---	---	Ave	74	54	---	---	---
2389.662	H	59.16	-1.18	57.98	Peak	74	54	-16.02	163	1.04
2389.662	H	36.52	-1.18	35.34	Ave	74	54	-18.66	163	1.04
Channel 11						Fundamental Frequency: 2462 MHz				
Frequency (MHz)	Ant-Pol H/V	Meter Reading (dBuV)	Corrected Factor (dB)	Result (dBuV/m)	Remark	Limit (dBuV/m)		Margin (dB)	Table Deg.	Ant High (m)
						Peak	Ave			
2483.666	V	51.36	-0.82	50.54	Peak	74	54	-23.46	175	1.02
---	V	---	---	---	Ave	74	54	---	---	---
2488.634	H	50.02	-0.81	49.21	Peak	74	54	-24.79	162	1.07
---	H	---	---	---	Ave	74	54	---	---	---

Modulation Standard: IEEE 802.11g

Channel 1						Fundamental Frequency: 2412 MHz				
Frequency (MHz)	Ant-Pol H/V	Meter Reading (dBuV)	Corrected Factor (dB)	Result (dBuV/m)	Remark	Limit (dBuV/m)		Margin (dB)	Table Deg.	Ant High (m)
						Peak	Ave			
2386.092	V	62.05	-1.19	60.86	Peak	74	54	-13.14	166	1.03
2386.092	V	35.63	-1.19	34.44	Ave	74	54	-19.56	166	1.03
2387.520	H	63.67	-1.19	62.48	Peak	74	54	-11.52	164	1.02
2387.520	H	41.36	-1.19	40.17	Ave	74	54	-13.83	164	1.02
Channel 11						Fundamental Frequency: 2462 MHz				
Frequency (MHz)	Ant-Pol H/V	Meter Reading (dBuV)	Corrected Factor (dB)	Result (dBuV/m)	Remark	Limit (dBuV/m)		Margin (dB)	Table Deg.	Ant High (m)
						Peak	Ave			
2485.874	V	58.83	-0.81	58.02	Peak	74	54	-15.98	175	1.07
2485.874	V	42.83	-0.81	42.02	Ave	74	54	-11.98	175	1.07
2487.392	H	60.17	-0.81	59.36	Peak	74	54	-14.64	169	1.02
2487.392	H	39.17	-0.81	38.36	Ave	74	54	-15.64	169	1.02



Modulation Standard: IEEE 802.11n HT20

Channel 1						Fundamental Frequency: 2412 MHz				
Frequency (MHz)	Ant-Pol H/V	Meter Reading (dBuV)	Corrected Factor (dB)	Result (dBuV/m)	Remark	Limit (dBuV/m)		Margin (dB)	Table Deg.	Ant High (m)
						Peak	Ave			
2389.152	V	62.13	-1.19	60.94	Peak	74	54	-13.06	176	1.05
2389.152	V	31.23	-1.19	30.04	Ave	74	54	-23.96	176	1.05
2383.950	H	61.98	-1.20	60.78	Peak	74	54	-13.22	161	1.04
2383.950	H	48.90	-1.20	47.70	Ave	74	54	-6.30	161	1.04
Channel 11						Fundamental Frequency: 2462 MHz				
Frequency (MHz)	Ant-Pol H/V	Meter Reading (dBuV)	Corrected Factor (dB)	Result (dBuV/m)	Remark	Limit (dBuV/m)		Margin (dB)	Table Deg.	Ant High (m)
						Peak	Ave			
2485.598	V	57.07	-0.81	56.26	Peak	74	54	-17.74	170	1.06
2485.598	V	42.45	-0.81	41.64	Ave	74	54	-12.36	170	1.06
2491.118	H	58.81	-0.79	58.02	Peak	74	54	-15.98	166	1.01
2491.118	H	40.20	-0.79	39.41	Ave	74	54	-14.59	166	1.01

Modulation Standard: IEEE 802.11n HT40

Channel 1						Fundamental Frequency: 2422 MHz				
Frequency (MHz)	Ant-Pol H/V	Meter Reading (dBuV)	Corrected Factor (dB)	Result (dBuV/m)	Remark	Limit (dBuV/m)		Margin (dB)	Table Deg.	Ant High (m)
						Peak	Ave			
2389.152	V	62.13	-1.19	60.94	Peak	74	54	-13.06	176	1.05
2389.152	V	31.23	-1.19	30.04	Ave	74	54	-23.96	176	1.05
2383.950	H	61.98	-1.20	60.78	Peak	74	54	-13.22	161	1.04
2383.950	H	48.90	-1.20	47.70	Ave	74	54	-6.30	161	1.04
Channel 11						Fundamental Frequency: 2452 MHz				
Frequency (MHz)	Ant-Pol H/V	Meter Reading (dBuV)	Corrected Factor (dB)	Result (dBuV/m)	Remark	Limit (dBuV/m)		Margin (dB)	Table Deg.	Ant High (m)
						Peak	Ave			
2485.598	V	57.07	-0.81	56.26	Peak	74	54	-17.74	170	1.06
2485.598	V	42.45	-0.81	41.64	Ave	74	54	-12.36	170	1.06
2491.118	H	58.81	-0.79	58.02	Peak	74	54	-15.98	166	1.01
2491.118	H	40.20	-0.79	39.41	Ave	74	54	-14.59	166	1.01

Notes:

1. Result = Meter Reading + Factor
2. Factor = Antenna Factor + Cable Loss – Amplifier
3. The resolution bandwidth of test receiver/spectrum analyzer is 1MHz and video bandwidth is 3 MHz (detector peak mode) for Peak detection at frequency above 1GHz.
4. The resolution bandwidth of test receiver/spectrum analyzer is 1MHz and video bandwidth is 3 MHz (detector sample mode) for Average detection at frequency above 1GHz.



### 11. Restricted Bands of Operation

Only spurious emissions are permitted in any of the frequency bands listed below:

MHz	MHz	MHz	GHz
0.09000 – 0.11000	16.42000 – 16.42300	399.9 – 410.0	4.500 – 5.250
0.49500 – 0.505**	16.69475 – 16.69525	608.0 – 614.0	5.350 – 5.460
2.17350 – 2.19050	16.80425 – 16.80475	960.0 – 1240.0	7.250 – 7.750
4.12500 – 4.12800	25.50000 – 25.67000	1300.0 – 1427.0	8.025 – 8.500
4.17725 – 4.17775	37.50000 – 38.25000	1435.0 – 1626.5	9.000 – 9.200
4.20725 – 4.20775	73.00000 – 74.60000	1645.5 – 1646.5	9.300 – 9.500
6.21500 – 6.21800	74.80000 – 75.20000	1660.0 – 1710.0	10.600 – 12.700
6.26775 – 6.26825	108.00000 – 121.94000	1718.8 – 1722.2	13.250 – 13.400
6.31175 – 6.31225	123.00000 – 138.00000	2200.0 – 2300.0	14.470 – 14.500
8.29100 – 8.29400	149.90000 – 150.05000	2310.0 – 2390.0	15.350 – 16.200
8.36200 – 8.36600	156.52475 – 156.52525	2483.5 – 2500.0	17.700 – 21.400
8.37625 – 8.38675	156.70000 – 156.90000	2655.0 – 2900.0	22.010 – 23.120
8.41425 – 8.41475	162.01250 – 167.17000	3260.0 – 3267.0	23.600 – 24.000
12.29000 – 12.29300	167.72000 – 173.20000	3332.0 – 3339.0	31.200 – 31.800
12.51975 – 12.52025	240.00000 – 285.00000	3345.8 – 3358.0	36.430 – 36.500
12.57675 – 12.57725	322.00000 – 335.40000	3600.0 – 4400.0	Above 38.6
13.36000 – 13.41000			

\*\* : Until February 1, 1999, this restricted band shall be 0.490-0.510 MHz

#### 11.1 Labeling Requirement

The device shall bear the following statement in a conspicuous location on the device:  
 This device complies with part 15 of the FCC Rules. Operation is subject to the following two conditions: (1) This device may not cause harmful interference, and (2) this device must accept any interference received, including interference that may cause undesired operation.