

VI. The Switch, Key and Indicator Light of Printer

6.1 Power Switch

The power switch controls the flow of power to the printer. The power switch is located on the front side of the printer. When the "I" switch is pressed, the printer is turned on; When the "O" of the switch is pressed, the printer is turned off.

 **Attention: Make sure the power supply is connected before turning on the printer.**

6.2 Keys and Indicators

RP410C Function description of buttons

Scenarios	Button operation	Corresponding functions
Switch off	Press and hold + turn on the printer	Print self-test page
Standby	Press and hold 3S	Enter label specification learning mode
Open the cover	Press and hold 10S	Restore factory settings
Standby	Press	Automatically feed one blank label sheet
Continuous printing process	Press	Pause printing
Pause printing	Press	Continue printing

RP410C Indicator description

Indicator status	Status description	Simple Troubleshooting
The green indicator is always on	Normal standby	/
The blue indicator flashes	RAM detection error	Contact the nearest service center
The pink indicator is always on	Print head is overheating	Automatically resume work after the printer cools down.
The red indicator is always on	Upper cover is not closed	Check whether the top cover is properly closed.
The red indicator flashes	No paper detected	Check whether paper has been loaded
The Yellow indicator is always on	Low input voltage	Replace the power adapter
The white indicator is always on	Pause printing	Press FEED button to print normally
The yellow indicator flashes	Paper jam	Open the cover to remove the jammed paper
The green indicator flashes slowly	Printer is working	/

❑ RP411 Function description of buttons

Scenarios	Button operation	Corresponding functions
Switch off	Press and hold + turn on the printer	Print self-test page
Standby	Press and hold 3S	Enter label specification learning mode
Open the cover	Press and hold 10S	Restore factory settings
Standby	Press	Automatically feed one blank label sheet
Continuous printing process	Press	Pause printing
Pause printing	Press	Continue printing

❑ RP411 Indicator description

Indicator status	Status description	Simple Troubleshooting
The green indicator is always on	Normal standby	/
The blue indicator flashes	RAM detection error	Contact the nearest service center
The pink indicator is always on	Print head is overheating	Automatically resume work after the printer cools down.
The red indicator is always on	Upper cover is not closed	Check whether the top cover is properly closed.
The red indicator flashes	No paper detected	Check whether paper has been loaded
The Yellow indicator is always on	Low input voltage	Replace the power adapter
The white indicator is always on	Pause printing	Press FEED button to print normally
The yellow indicator flashes	Paper jam	Open the cover to remove the jammed paper
The green indicator flashes slowly	Printer is working	/

❑ RP410Y Function description of buttons

Scenarios	Button operation	Corresponding functions
Switch off	Press and hold + turn on the printer	Print self-test page
Standby	Press and hold 3S	Enter label specification learning mode
Open the cover	Press and hold 10S	Restore factory settings
Standby	Press	Automatically feed one blank label sheet
Continuous printing process	Press	Pause printing
Pause printing	Press	Continue printing

❑ RP410Y Indicator description

Indicator status	Status description	
Indicator always lights up	Normal standby	
Indicator flashes	Buzzer alarm	
Buzzer alarm (common)	2 Sounds	Printer mechanism error
	3 Sounds	Paper shortage error
	5 Sounds	Overheating error
	6 Sounds	Cover opening error
	7 Sounds	Seam label error

❑ RP410 Function description of buttons

Scenarios	Button operation	Corresponding functions
Switch off	Press and hold + turn on the printer	Print self-test page
Standby	Press and hold 3S	Enter label specification learning mode
Open the cover	Press and hold 10S	Restore factory settings
Standby	Press	Automatically feed one blank label sheet
Continuous printing process	Press	Pause printing
Pause printing	Press	Continue printing

❑ RP410 Indicator description

Three-color light definition

Indicator status	Status description	Simple Troubleshooting
The green indicator is always on	Normal standby	/
The blue indicator flashes	RAM detection error	Contact the nearest service center
The pink indicator is always on	Print head is overheating	Automatically resume work after the printer cools down.
The red indicator is always on	Upper cover is not closed	Check whether the top cover is properly closed.
The red indicator flashes	No paper detected	Check whether paper has been loaded
The Yellow indicator is always on	Low input voltage	Replace the power adapter
The white indicator is always on	Pause printing	Press FEED button to print normally
The yellow indicator flashes	Paper jam	Open the cover to remove the jammed paper
The green indicator flashes slowly	Printer is working	/

Monochrome light definition

Indicator status	Status description	
Indicator always lights up	Normal standby	
Indicator flashes	Buzzer alarm	
Buzzer alarm (common)	2 Sounds	Printer mechanism error
	3 Sounds	Paper shortage error
	5 Sounds	Overheating error
	6 Sounds	Cover opening error
	7 Sounds	Seam label error

☺ Remarks: RP410 indicator has multiple version definitions, please refer to the actual product

VII. Printer Test

7.1 Print self-test page

When the printer is initially installed or there are any problems with the printer, you can run self-test program to confirm the following status: firmware version, printer parameter setting status, print quality, and related setting information of external devices, etc. After confirming that there is no problem with the printer after the self-test, please check other devices or software. This function runs independently of other devices or software.

The self-test method is as follows:

1. Confirm that the printer is connected to power supply and the paper roll is loaded correctly.
2. Confirm that the printer is turned off and the top cover is closed in place.
3. Press and hold the FEED button, then press the POWER button to turn on the printer; release the button after the printer is turned on.

7.2 Print with the Window driver

1. To install Windows driver, please refer to "Driver Installation Instruction".
2. Set the "port" of the Windows driver as the appropriate interface to use.
Print the test page with the "Print test page" function of Windows driver.

7.3 Label learning

 **Note: In the following cases, the user can perform label positioning learning so that the printer can better position the label:**

- Install and use the printer for the first time.
- First use of printer after sensor cleaning.
- Reuse the printer after it is not used for a long time.
- Replace with a new type of paper roll.
- The printer cannot recognize the mark effectively during printing.

When the printer is ready, press and hold the FEED button for 3s until the standby status indicator flashes twice, release the button, and the printer will start learning and feed paper. If the printer learns under continuous paper mode, the learning is invalid.

Users can also complete the learning through the printer tool software (refer to "Instruction for Printer Setting Tool").

 **Note: After learning, you can re-open the top cover and place the blank label paper just fed during learning back for printing to avoid paper waste.**

VIII. Cleaning the Printer

8.1 Cleaning the Printer Head

Clean the print head when one of the following conditions occurs to the printer:

- (1) Printing is not clear;
- (2) A vertical column of the printed page is not clear;
- (3) The paper feeding noise is high.

The print head cleaning steps are as follows:

- (1) Turn off the power supply of the printer, open the upper cover and remove the paper if exists.
- (2) If printing has just been completed, wait for the print head to cool completely;
- (3) Clean the printer head with a soft cotton moistened with ethyl alcohol.
- (4) After waiting for absolute ethyl alcohol to volatilize completely, close the upper cover and try printing again.

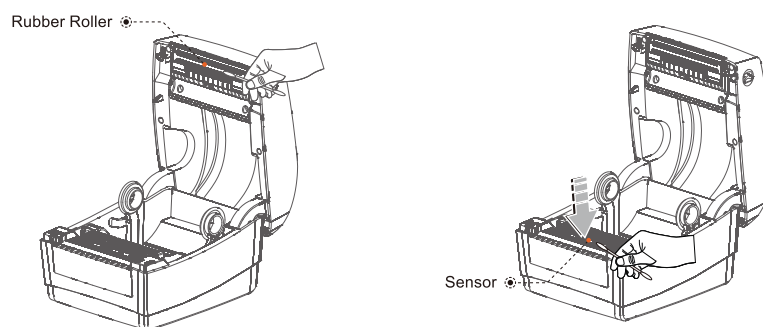

8.2 Cleaning the Sensor

Clean the paper shortage sensor when one of the following conditions occurs to the printer:

- (1) In the printing process, the printer occasionally stops printing and alarms for paper shortage;
- (2) No alarm for paper shortage.

The paper shortage sensor cleaning steps are as follows:

- (1) Turn off the power supply of the printer, open the upper cover, and remove the paper if there is any;
- (2) Wipe off the dust and stain on the sensor surface with soft cotton cloth (which should be dried) dipped in absolute ethyl alcohol.
- (3) After waiting for absolute ethyl alcohol to volatilize completely, close the upper cover and try to start the machine again.

8.3 Cleaning the Printing Rubber Roller

When one of the following conditions occurs to the printer, the printing rubber roller should be cleaned:

- (1) Printing is not clear;
- (2) A vertical column of the printed page is not clear;
- (3) The paper feeding noise is high.

The printing Rubber Rollers cleaning steps are as follows:

- (1) Turn off the power of the printer and open the upper cover;
- (2) Use a soft cotton cloth (which should be dried) dipped in a neutral detergent to wipe off dust and stains on the surface of the printing rubber roller;
- (3) Close the upper cover after the cleaning agent is completely volatilized.

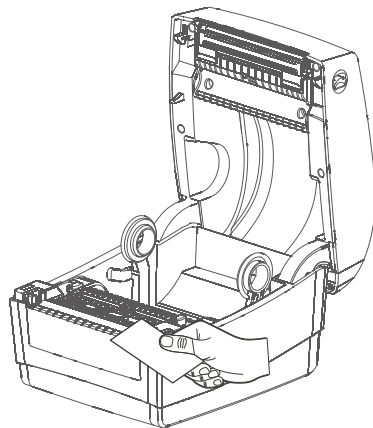

⚠ Attention:

- (1) The power supply must be turned off during the daily maintenance of the printer.
- (2) Do not touch the surface of the print head with hands and metal objects, and do not scratch the surface of the print head, printing rubber roller and sensor with tweezers and other tools.
- (3) The organic solvents such as gasoline and acetone shall not be used.
- (4) Wait until absolute ethyl alcohol is completely volatilized, then turn on the power supply to continue printing.

IX. Troubleshooting

The table below shows common problems and solutions for operators.

If you have followed the simple troubleshooting methods but the printer is still not functioning properly, please contact the customer service department of your dealer for assistance.

Fault Phenomenon	Cause	Solution
POWER indicator is off	a. The AC plug and the power supply plug are not properly connected to the printer socket.	a. Check the power connection and confirm that the AC plug and the power supply plug are properly connected to the printer socket. b. Turn on the printer.
Unable to print	a. The communication cable is not properly connected to the printer and PC host. b. Communication interface setting error. c. Print status error.	a. Reconnect the communication cable. b. Refer to 6.2 "Printer Indicator Information" of the Manual, and confirm whether the standby status indicator is always on.
Incomplete print content	a. The paper is not centered.	a. Adjust the paper position. b. Set the correct label size.
Incorrect positioning	a. Label learning is not performed. b. Seam label detection photocoupler is offset. c. Wrong mode selected.	a. Label learning is performed. b. Open the cover to confirm whether the seam label detection component is offset. For black label paper, move the seam label detection component according to the black label position so that the detection photocoupler can detect the black label. Label paper/continuous paper: The detection photocoupler must be in the paper range. c. Use the setting tool to open the printer information and confirm whether the paper type is the same as the paper loaded in the printer, which can be changed by using the setting tool.
Poor print result	a. Paper loading error. b. Print density/speed setting error. c. Print head/rubber roller has dust or adhesive accumulation. d. The print head is damaged.	a. Reload the paper. b. Readjust the print density/speed of printer by using the setting tool or the software. Printing density can be coarsely tuned with the setting tool and finely tuned with the driver. c. Clean the print head/rubber roller. (refer to 8.1 "Cleaning Print Head"/8.2 "Cleaning Sensor"/8.3 "Cleaning Printing Rubber Roller" of the Manual.) d. Use the setting tool to detect bad point of head piece. If the print head is damaged, please contact the customer service department of your dealer for repairs.

X. FCC WARNING

FCC Statement:

This device complies with part 15 of the FCC Rules. Operation is subject to the following two conditions: (1) This device may not cause harmful interference, and (2) this device must accept any interference received, including interference that may cause undesired operation.

This equipment has been tested and found to comply with the limits for a Class B digital device, pursuant to part 15 of the FCC Rules. These limits are designed to provide reasonable protection against harmful interference in a residential installation. This equipment generates, uses and can radiate radio frequency energy and, if not installed and used in accordance with the instructions, may cause harmful interference to radio communications. However, there is no guarantee that interference will not occur in a particular installation. If this equipment does cause harmful interference to radio or television reception, which can be determined by turning the equipment off and on, the

user is encouraged to try to correct the interference by one or more of the following measures:

- Reorient or relocate the receiving antenna.
- Increase the separation between the equipment and receiver.
- Connect the equipment into an outlet on a circuit different from that to which the receiver is connected.
- Consult the dealer or an experienced radio/TV technician for help.

Caution: Any changes or modifications not expressly approved by the party responsible for compliance could void the user's authority to operate the equipment.

This equipment complies with FCC radiation exposure limits set forth for an uncontrolled environment. This transmitter must not be co-located or operating in conjunction with any other antenna or transmitter.

RF exposure warning:

This equipment complies with radiation exposure limits set forth for an uncontrolled environment. This equipment should be installed and operated with Minimum distance 20cm between the radiator and your body.



Rongta Technology (Xiamen) Group Co., Ltd.

ADD: No.88, Tonghui South Road, Tongan, Xiamen, China.

WEB: www.rongtatech.com

TEL: 0086-592-5666129 FAX: 0086-592-5659169

