

Catalogue

1.	Description	3
2.	Features	3
3.	Application.....	3
4.	Typical application circuit.....	3
5.	Electrical Characteristics.....	4
6.	Pin Definition	4
7.	Accessories	
8.	Mechanical Dimension(mm):.....	5

Note: Revision History

Revision	Date	Comment
V1.0	2014-9-5	First release
V2.0	2016-5-5	Some parameters revised

1. Description

2.4G RF module with nRF2401+ is a high integrated wireless module, which worked in 2.4GHz of ISM band. 2.4G RF module with nRF2401+ adopts Nordic's RF chip nRF24L01+ and high efficiency RF amplifier. The feature of high data rate (maximum 2Mbps),

★ **This module got CE、FCC、ETSI approvals.**

2. Features

- Frequency Range: 2402-2482MHz
- Modulation: GFSK
- Sensitivity up to: -102dBm@250Kpbs
- Data rate: 250K, 1Mbps, 2Mbps
- GFSK Modulation, 126 Channel
- FIFO: 32bytes
- Ultra low power off mode
- Support functions of frequency hopping
- Timing wake-up function
- Internal integrated voltage regulator
- operating voltage range: 1.9-3.6 V
- Operating temperature range: -40~+85°C

3. Application

- Wireless remote control
- Smart Home
- Toy control
- Tire Pressure Monitoring
- health monitoring
- Tag reader

4. Typical application circuit

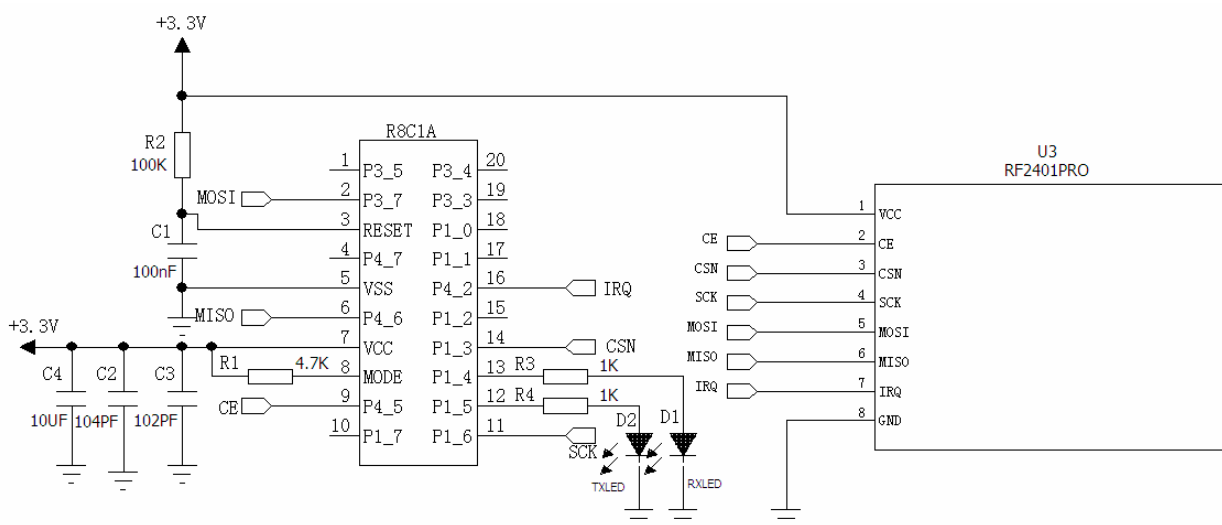

5. Electrical Characteristics

★Below parameters is measured at 3.0V

Parameter	Min.	Type.	Max.	Unit	Conditions
Operation conditions					
Operating voltage range	1.9	3.3	3.6	V	
Operating temperature range	-40		85	°C	
Current consumption					
RX Current		<14		mA	
TX Current		12		mA	@0dBm
Sleep Current		<1		uA	
RF Parameters					
Frequency range	2402		2482	MHz	
Modulation rate	250		2000	Kbps	GFSK
Output power		0		dBm	
RX sensitivity		-94		dBm	@data=250kbps

6. Pin Definition

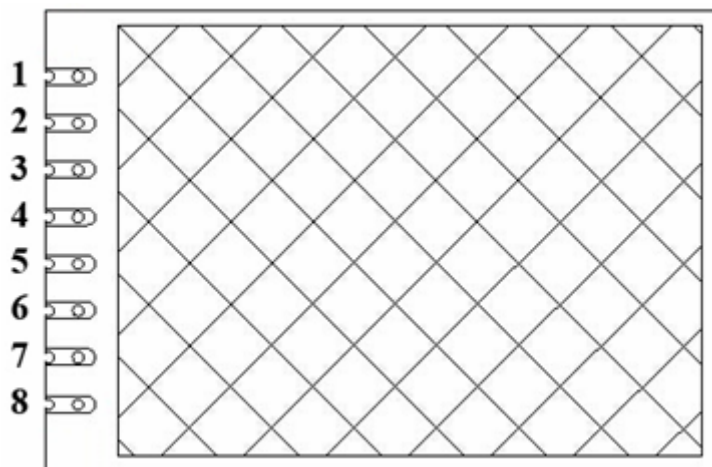

Pin No.	Pin Definitions	Description
1	VCC	Connect to VCC (1.9-3.6V)
2	CE	Chip enable
3	CSN	CSN of SPI interface
4	SCK	SCK or SPI interface
5	MOSI	MOSI of SPI interface
6	MISO	MISO of SPI interface
7	IRQ	Interrupt output, active low
8	GND	Connect to ground

7. Mechanical

Dimension(mm):

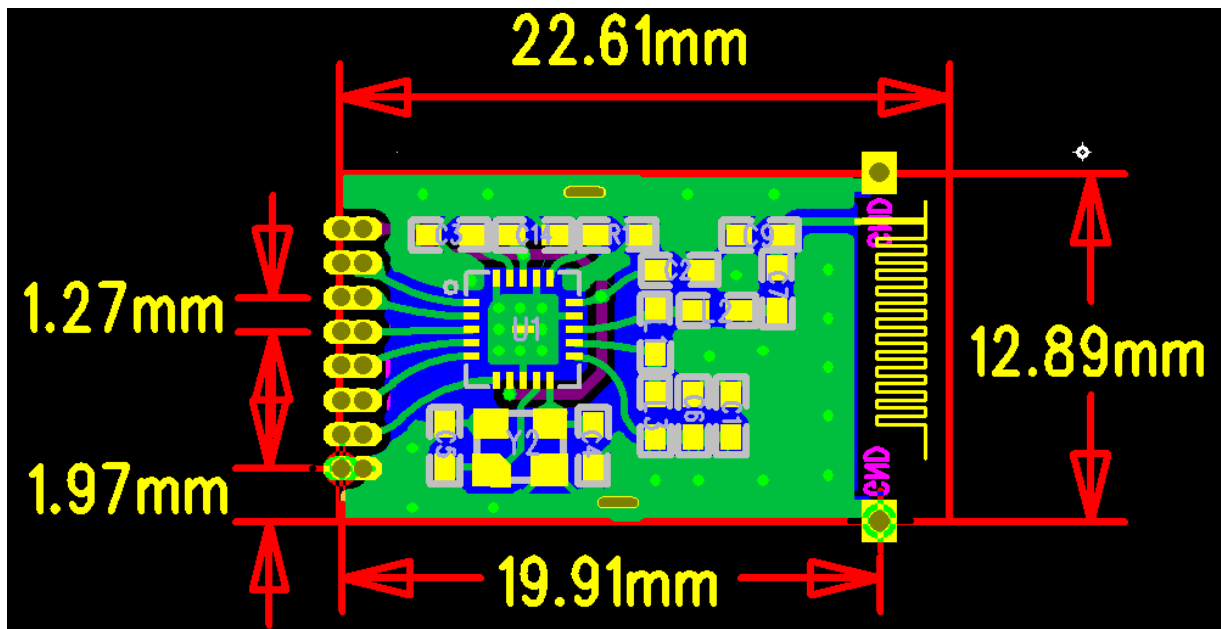

Appendix 1:

The module is equipped with a standard DEMO board for customer to debug the program and test distance. It shows as below:

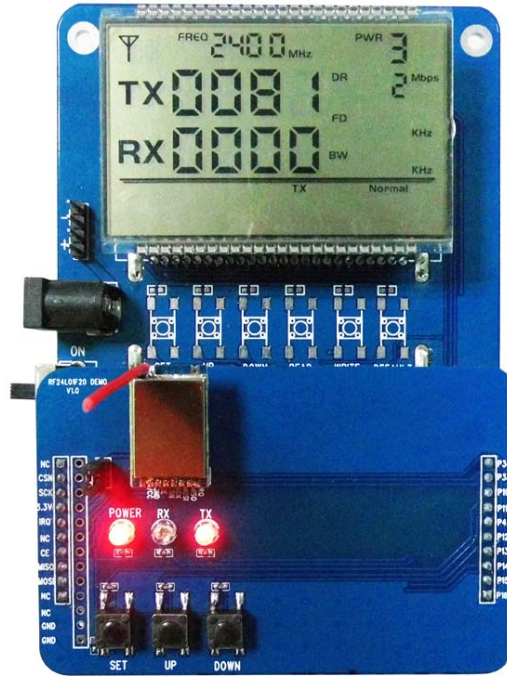

The LCD Full Segment is as below:

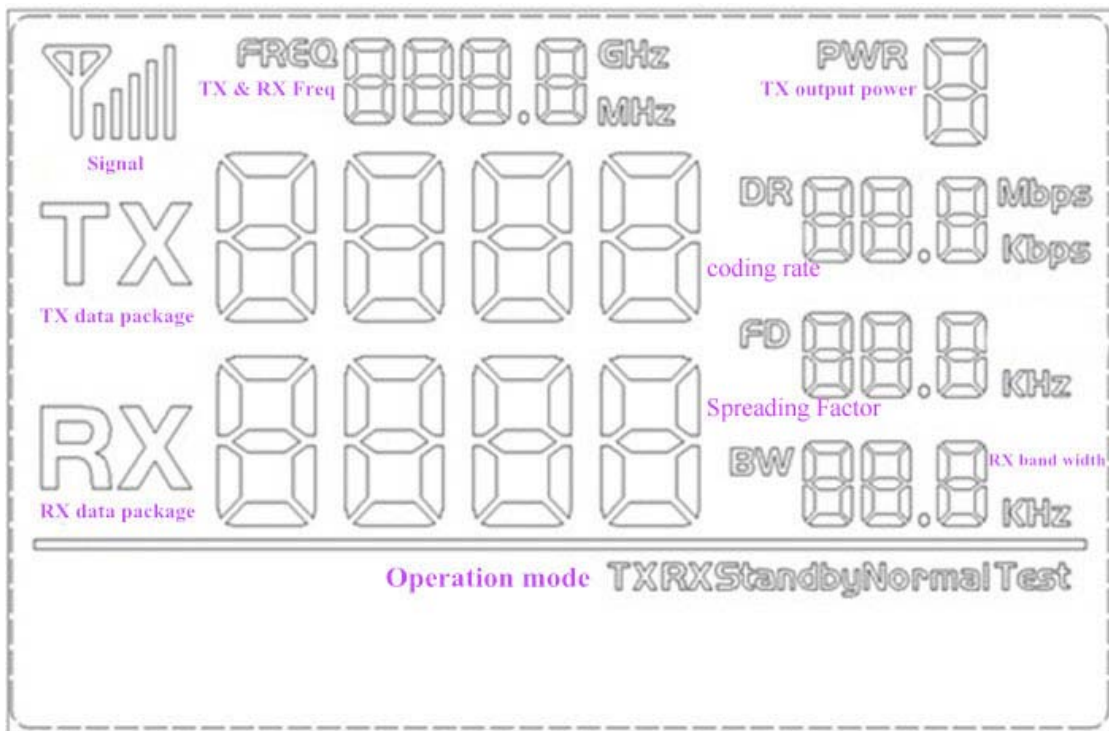

Users can set the parameters of the RF module such as working mode /frequency / transmitter power / transmission data rate through the buttons, and measure the wireless communication distance.

➤ **Working Mode:**

- 1) Master Mode: Send 1 packet per second, and waiting for the acknowledge;
- 2) Slave Mode: Stay in Rx mode to wait for the data from the master, it will send back the acknowledged signal after received the data from the master.
- 3) Tx Test Mode: RF module continuously transmit signal;

- 4) Rx Test Mode: RF module is always in Rx mode;
- 5) Standby Mode: RF module is always in standby state.

➤ **Button Operation:**

1) [SET] Button

Press the [SET] button to enter into setting mode; Or press the [SET] button to be out of the setting mode upon the last parameter is done.

2) [UP/Down] Button

In setting mode, press the [UP/Down] button to increase/decrease the value of flash icon.

Note: The DEMO board has FLASH memory inside, all the setting parameters will be saved automatically and keep unchanged even power-off.

Appendix 2: SMD Reflow Chart

We recommend you should obey the IPC related standards in setting the reflow profile:

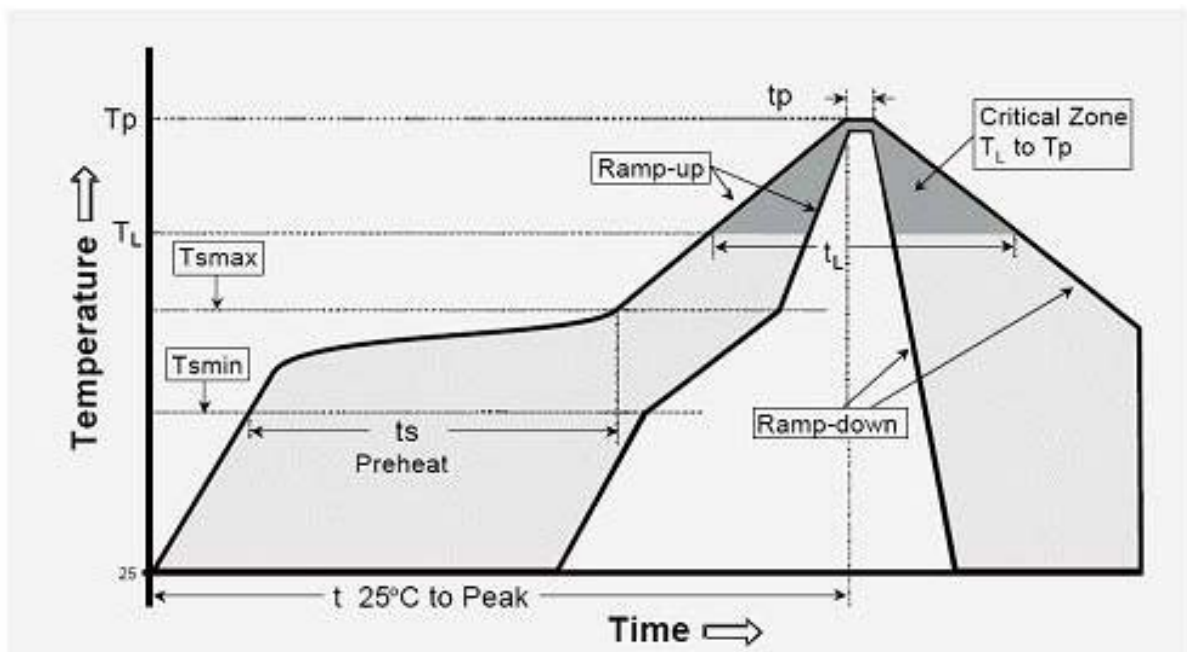

IPC/JEDEC J-STD-020B the condition for lead-free reflow soldering	big size components (thickness $\geq 2.5\text{mm}$)
The ramp-up rate (Tl to Tp)	3°C/s (max.)
preheat temperature	
- Temperature minimum (T _{min})	150°C
- Temperature maximum (T _{max})	200°C
- preheat time (t _s)	60~180s
Average ramp-up rate(T _{max} to Tp)	3°C/s (Max.)
- Liquidous temperature(T _L)	217°C
- Time at liquidous(t _L)	60~150 second
peak temperature(T _p)	245+/-5°C

FCC WARNING

This device complies with part 15 of the FCC Rules. Operation is subject to the condition that this device does not cause harmful interference (1) this device may not cause harmful interference, and (2) this device must accept any interference received, including interference that may cause undesired operation.

Changes or modifications not expressly approved by the party responsible for compliance could void the user's authority to operate the equipment.

NOTE: This equipment has been tested and found to comply with the limits for a Class B digital device, pursuant to Part 15 of the FCC Rules. These limits are designed to provide reasonable protection against harmful interference in a residential installation. This equipment generates, uses and can radiate radio frequency energy and, if not installed and used in accordance with the instructions, may cause harmful interference to radio communications. However, there is no guarantee that interference will not occur in a particular installation. If this equipment does cause harmful interference to radio or television reception, which can be determined by turning the equipment off and on, the user is encouraged to try to correct the interference by one or more of the following measures:

- Reorient or relocate the receiving antenna.
- Increase the separation between the equipment and receiver.
- Connect the equipment into an outlet on a circuit different from that to which the receiver is connected.
- Consult the dealer or an experienced radio/TV technician for help.

The device has been evaluated to meet general RF exposure requirement. The device can be used in portable exposure condition without restriction.

FCC ID: 2AD66-RF2401PRO

This device is intended only for OEM integrators under the following conditions:

- 1) The antenna must be installed such that 20 cm is maintained between the antenna and users, and
- 2) This device and its antenna(s) must not be co-located with any other transmitters except in accordance with FCC multi-transmitter product procedures. Referring to the multi-transmitter policy, multiple-transmitter(s) and module(s) can be operated simultaneously without C2P.
- 3) For all products market in US, OEM has to limit the operation channels in CH00 to CH80 for 2.4G band by supplied firmware programming tool. OEM shall not supply any tool or info to the end-user regarding to Regulatory Domain change.

USERS MANUAL OF THE END PRODUCT:

In the users manual of the end product, the end user has to be informed to keep at least 20cm separation with the antenna while this end product is installed and operated. The end user has to be informed that the FCC radio-frequency exposure guidelines for an uncontrolled environment can be satisfied. The end user has to also be informed that any changes or modifications not expressly approved by the manufacturer could void the user's authority to operate this equipment. If the size of the end product is smaller than 8x10cm, then additional FCC part 15.19 statement is required to be available in the users manual: This device complies with Part 15 of FCC rules. Operation is subject to the following two conditions: (1) this device may not cause harmful interference and (2) this device must accept any interference received, including interference that may cause undesired operation.

LABEL OF THE END PRODUCT:

The final end product must be labeled in a visible area with the following " Contains FCC ID: **2AD66-RF2401PRO** ". If the size of the end product is larger than 8x10cm, then the following FCC part 15.19 statement has to also be available on the label: This device complies with Part 15 of FCC rules. Operation is subject to the following two conditions: (1) this device may not cause harmful interference and (2) this device must accept any interference received, including interference that may cause undesired operation.