

LORA RF Transceiver Module

Product Specification

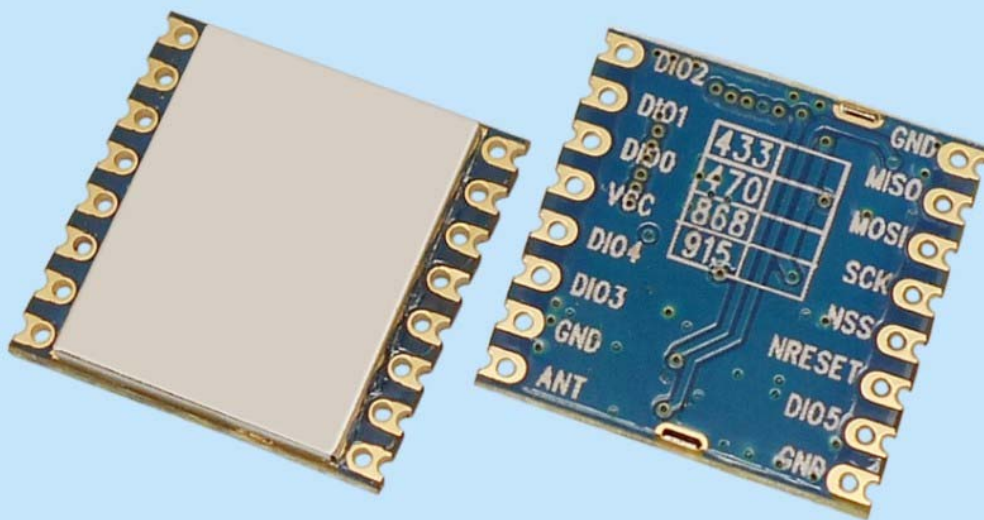

Catalogue

1. Overview.....	- 3 -
2. Features	- 3 -
3. Applications	- 3 -
4. Electrical Characteristics	- 4 -
5. Schematic.....	- 5 -
6. Speed rate correlation table.....	- 5 -
7. Pin definition.....	- 6 -
8. Accessories.....	- 7 -
9. Mechanical Dimensions (Unit:mm)	- 8 -
10. Order information	- 8 -
Appendix 1: SMD Reflow Chart	- 9 -

Note: Revision History

Revision	Date	Comment
V1.0	2017-3	First release
V1.1	2017-06	Logo updated

1. Overview

Lora1276-C1 integrates Semtech RF transceiver chip SX1276, which adopts LoRa TM Spread Spectrum modulation frequency hopping technique. The features of long distance and high sensitivity (-139 dBm) make this module perform better than FSK and GFSK module. Multi-signal won't affect each other even in crowd frequency environment; it comes with strong anti-interference performance. This module is 100mW and ultra small size, widely used in AMR,remote industrial control filed.

2. Features

- Frequency Range: 902-928MHz
(Customizable:137~1020MHz)
- Sensitivity up to -139dBm @Lora
- Maximum output power: 20 dBm
- 13mA@receiver mode
- Sleep current <200 nA
- Data transfer rate: @FSK,1.2-300 Kbps
- @Lora TM, 0.018-37.5 Kbps
- Lora TM, FSK, GFSK & OOK Modulation mode
- Built-in ESD Protection
- 127 dB Dynamic Range RSSI
- Packet engine up to 256 bytes with FIFO and CRC
- Hopping frequency
- Built-in temperature sensor and low battery indicator
- Excellent blocking immunity
- Operating Temperature Range: -40 ~ +85 °C

3. Applications

- Remote meter reading
- Industrial control
- Home automation remote sensing
- Toys control
- Sensor network
- Tire pressure monitoring
- Health monitoring
- Wireless PC peripherals

4. Electrical Characteristics

Parameter	Min	Typ.	Max.	Unit	Condition
Operation condition					
Working voltage	1.8	3.3	3.7	V	
Temperature range	-40		85	°C	
Current consumption					
RX current		10.8		mA	
TX current		120		mA	@20dBm
Sleep current		<0.2		uA	
RF parameter					
Frequency range	800	868	900	MHz	@868MHZ
	900	915	1000	MHz	@915MHZ
Modulation rate	1.2		300	Kbps	FSK
	0.018		37.5	Kbps	LoraTM
Output power range	-1		20	dBm	
Receiving sensitivity		-123		dBm	@FSK data=1.2kbps, Fdev=10kHz
		-139		dBm	@Lora BW=125KHz_SF = 12_CR=4/5

Note: According to the design of the module, the maximum bit of register 0x09 must be set as 1. PaSelect must be set 1;

RegPaConfig (0x09)	7	PaSelect	rw	0x00	Selects PA output pin 0 → RFO pin. Output power is limited to +14 dBm. 1 → PA_BOOST pin. Output power is limited to +20 dBm
	6-4	MaxPower	rw	0x04	Select max output power: $P_{max}=10.8+0.6*MaxPower$ [dBm]
	3-0	OutputPower	rw	0x0f	$P_{out}=P_{max}-(15-OutputPower)$ if PaSelect = 0 (RFO pin) $P_{out}=17-(15-OutputPower)$ if PaSelect = 1 (PA_BOOST pin)

5. Schematic

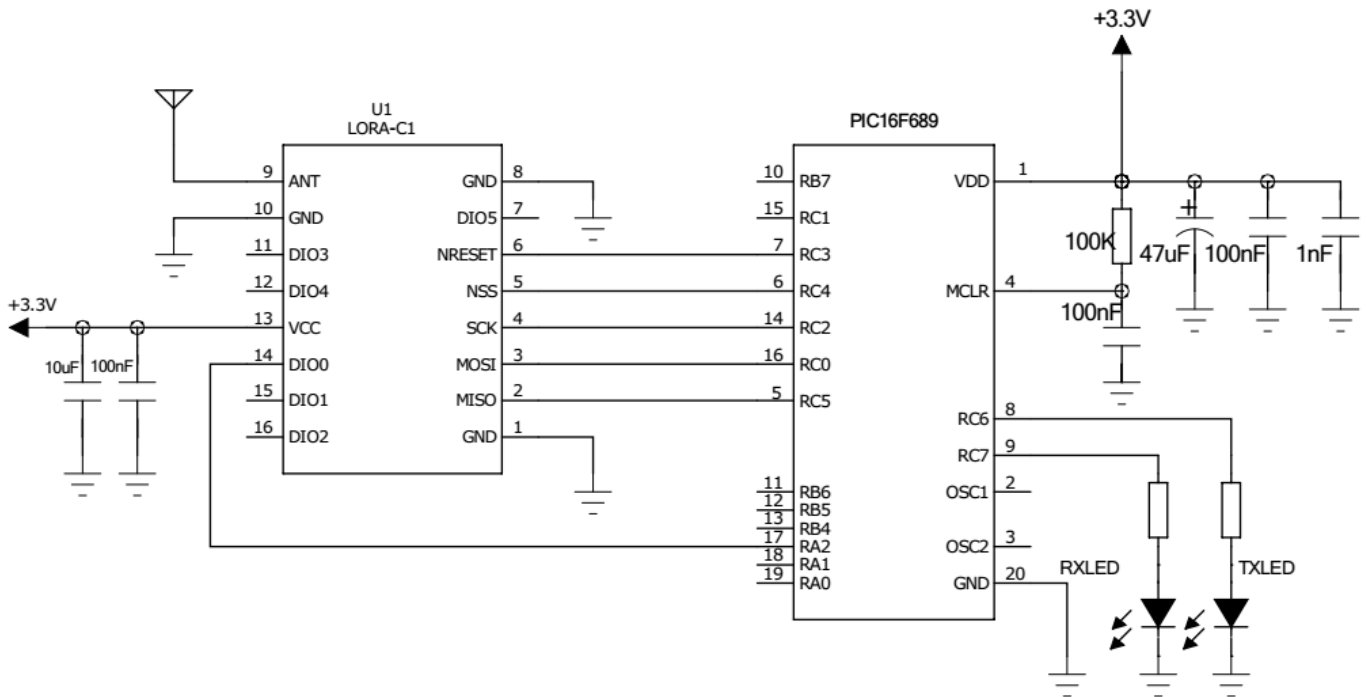

6. Speed rate correlation table

SignalBandWidth	SpreadingFactor	Sensitivity(dbm)	ActualBandRate(pbs)
62.5kHz	SF=7	-126	2169
62.5kHz	SF=8	-129	1187
62.5kHz	SF=9	-132	656
62.5kHz	SF=10	-135	296
62.5kHz	SF=11	-137	164
62.5kHz	SF=12	-139	91
125kHz	SF=7	-123	4338
125kHz	SF=8	-126	2375
125kHz	SF=9	-129	1312
125kHz	SF=10	-132	733
125kHz	SF=11	-133	328
125kHz	SF=12	-136	183
250kHz	SF=7	-120	8676
250kHz	SF=8	-123	4750
250kHz	SF=9	-125	2624
250kHz	SF=10	-128	1466
250kHz	SF=11	-130	778
250kHz	SF=12	-133	366
500kHz	SF=7	-118	17353
500kHz	SF=8	-121	9501
500kHz	SF=9	-124	5249
500kHz	SF=10	-127	2932
500kHz	SF=11	-129	1557
500kHz	SF=12	-130	830

7. Pin definition

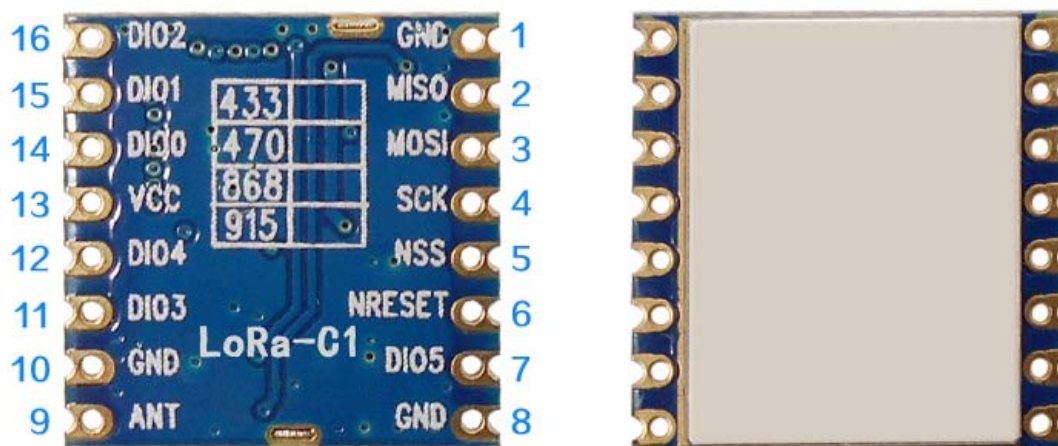

Pin NO.	Pin name	Description
1	GND	Power ground
2	MISO	SPI Output for SPI data
3	MOSI	SPI Input for SPI data
4	SCK	Serial clock for SPI interface
5	NSS	SPI enable
6	NRESET	Reset input
7	DIO5	Digital I/O
8	GND	Power ground
9	ANT	Connect with 50 ohm coaxial antenna
10	GND	Power ground
11	DIO3	Digital I/O
12	DIO4	Digital I/O
13	VCC	Power supply (default 3.3V)
14	DIO0	Digital I/O
15	DIO1	Digital I/O
16	DIO2	Digital I/O

8. Accessories

1)Antenna

antenna is very important for RF communication, its performance will affect the communication directly. Module needs antenna in 50ohm. Common antenna has rubber straight/ elbow/ foldable rod and sucker antenna and etc. Users can order accordingly. To ensure module in the best performance, we suggest to use the our antenna

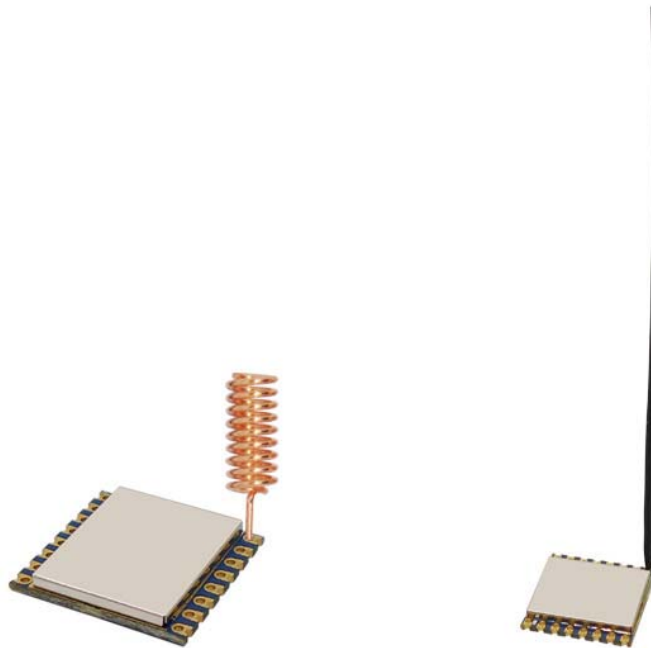

★To ensure modules get the best performance, user must obey the following principles when using the antennas:

- Put the antenna away from the ground and obstacles as possible as you could;
- If you choose the sucker antenna, pull straight the lead wire as possible as it can be, the sucker under arches should be attached on the metal object.

9. Mechanical Dimensions (Unit:mm)

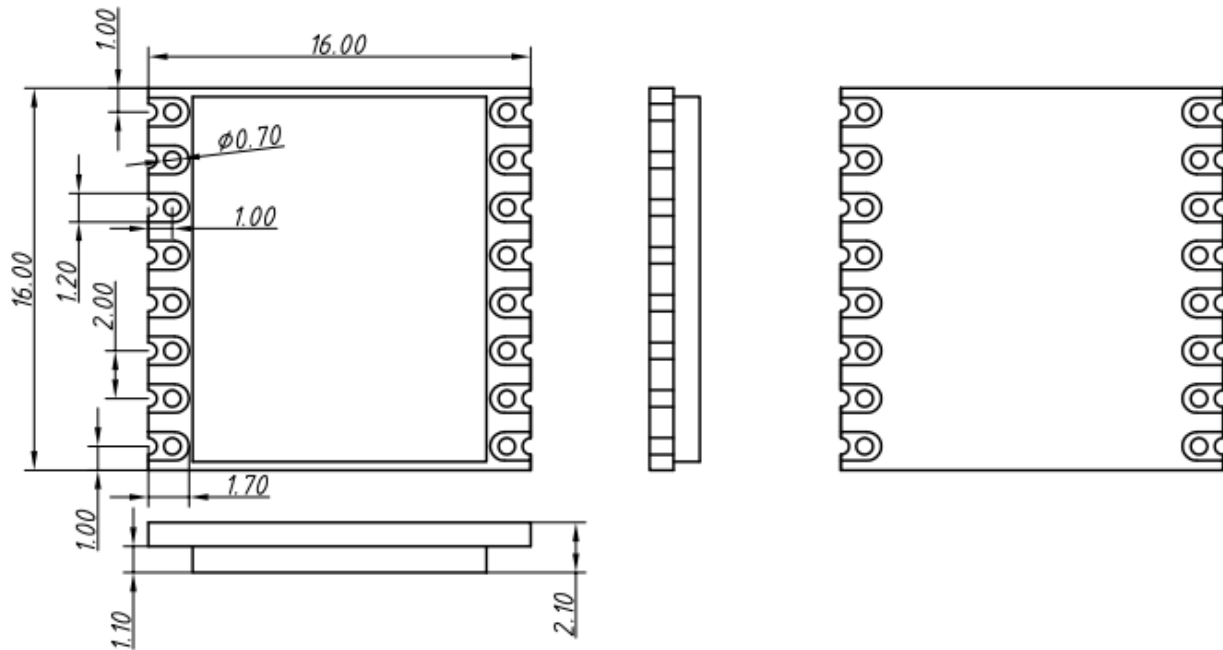

10. Order information

a) LoRa1276-C1-915

- 1) Power supply ripple is too large;
- 2) The antenna types do not match, or not properly installed;
- 3) The surrounding environment is harsh, strong interference sources;
- 4) Surrounding co-channel interference;

This device is intended only for OEM integrators under the following conditions:

- 1) The antenna must be installed such that 20 cm is maintained between the antenna and users, and
- 2) This device and its antenna(s) must not be co-located with any other transmitters except in accordance with FCC multi-transmitter product procedures. Referring to the multi-transmitter policy, multiple-transmitter(s) and module(s) can be operated simultaneously without C2P.
- 3) For all products market in US, **OEM has to limit the operation channels for 915MHz band by supplied firmware programming tool.** OEM shall not supply any tool or info to the end-user regarding to Regulatory Domain change.

USERS MANUAL OF THE END PRODUCT:

In the users manual of the end product, the end user has to be informed to keep at least 20cm separation with the antenna while this end product is installed and operated. The end user has to be informed that the FCC radio-frequency exposure guidelines for an

uncontrolled environment can be satisfied. The end user has to also be informed that any changes or modifications not expressly approved by the manufacturer could void the user's authority to operate this equipment. If the size of the end product is smaller than 8x10cm, then additional FCC part 15.19 statement is required to be available in the users manual: This device complies with Part 15 of FCC rules. Operation is subject to the following two conditions: (1) this device may not cause harmful interference and (2) this device must accept any interference received, including interference that may cause undesired operation.

LABEL OF THE END PRODUCT:

The final end product must be labeled in a visible area with the following "Contains FCC ID:2AD66-1276C1". If the size of the end product is larger than 16x16cm, then the following FCC part 15.19 statement has to also be available on the label: This device complies with Part 15 of FCC rules. Operation is subject to the following two conditions: (1) this device may not cause harmful interference and (2) this device must accept any interference received, including interference that may cause undesired operation.

Appendix 1: SMD Reflow Chart

We recommend you should obey the IPC related standards in setting the reflow profile:

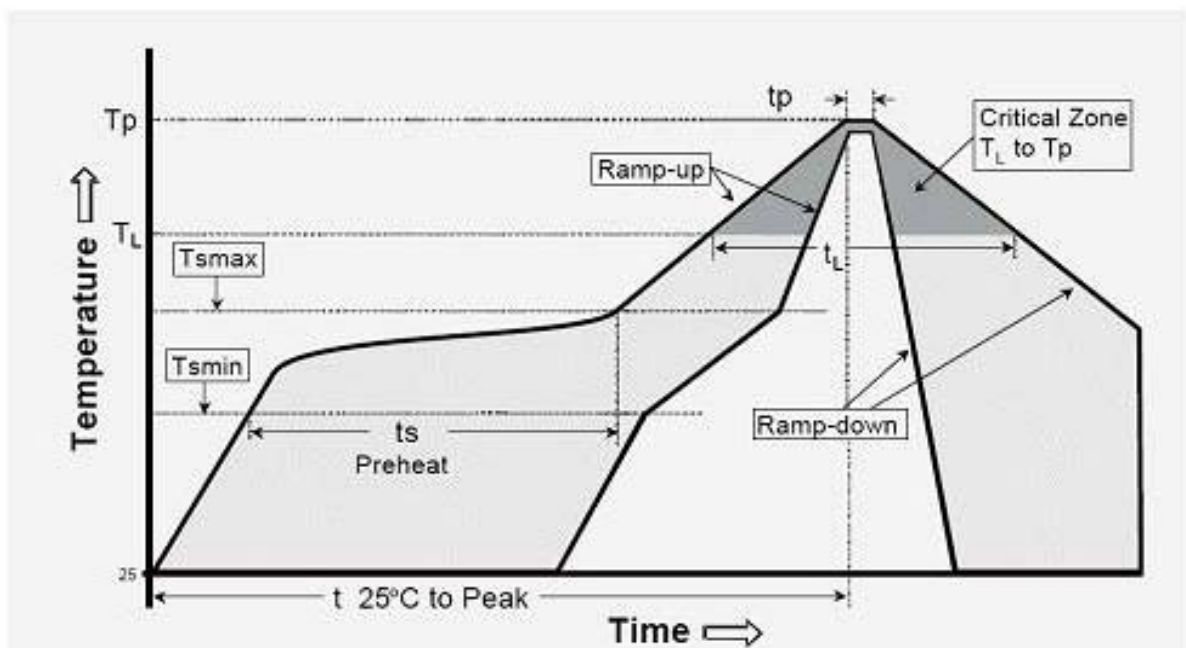

IPC/JEDEC J-STD-020B the condition for lead-free reflow soldering	big size components (thickness $\geq 2.5\text{mm}$)
The ramp-up rate (Tl to Tp)	3°C/s (max.)
preheat temperature	
- Temperature minimum (T _{min})	150°C
- Temperature maximum (T _{max})	200°C
- preheat time (t _s)	60~180s
Average ramp-up rate(T _{max} to Tp)	3°C/s (Max.)
- Liquidous temperature(T _L)	217°C
- Time at liquidous(t _L)	60~150 second
peak temperature(T _p)	245+/-5°C

FCC WARNING

This device complies with part 15 of the FCC Rules. Operation is subject to the following two conditions: (1) this device may not cause harmful interference, and (2) this device must accept any interference received, including interference that may cause undesired operation.

Any changes or modifications not expressly approved by the party responsible for compliance could void the user's authority to operate the equipment.

NOTE: This equipment has been tested and found to comply with the limits for a Class B digital device, pursuant to Part 15 of the FCC Rules. These limits are designed to provide reasonable protection against harmful interference in a residential installation. This equipment generates, uses and can radiate radio frequency energy and, if not installed and used in accordance with the instructions, may cause harmful interference to radio communications. However, there is no guarantee that interference will not occur in a particular installation. If this equipment does cause harmful interference to radio or television reception, which can be determined by turning the equipment off and on, the user is encouraged to try to correct the interference by one or more of the following measures:

- Reorient or relocate the receiving antenna.
- Increase the separation between the equipment and receiver.
- Connect the equipment into an outlet on a circuit different from that to which the receiver is connected.
- Consult the dealer or an experienced radio/TV technician for help.

To maintain compliance with FCC's RF Exposure guidelines, This equipment should be installed and operated with minimum distance between 20cm the radiator your body: Use only the supplied antenna.

FCC ID: 2AD66-1276C1