



# TEST REPORT

## FCC PART 15 SUBPART C 15.247

Test report  
On Behalf of  
Kanen Electronics Co., Ltd  
For  
Wireless Headphones

Model No.: M10, K22

FCC ID: 2AD5N-M10

Prepared for : Kanen Electronics Co., Ltd  
No.78,East Liuhua Rd, Xiakou Ind. Zone, Dongcheng District,523115,  
Dongguan,Guangdong, China

Prepared By : Shenzhen HUAKE Testing Technology Co., Ltd.  
1-2/F, Building 19, Junfeng Industrial Park, Chongqing Road, Heping  
Community, Fuhai Street, Bao'an District, Shenzhen, Guangdong, China

Date of Test: Jan. 16, 2019 ~ Jan. 22, 2019

Date of Report: Jan. 22, 2019

Report Number: HK1901210174E



### TEST RESULT CERTIFICATION

**Applicant's name**..... Kanen Electronics Co., Ltd  
 Address ..... No.78,East Liuhua Rd, Xiakou Ind. Zone, Dongcheng District,523115, Dongguan,Guangdong, China  
**Manufacture's Name** ..... Kanen Electronics Co., Ltd  
 Address ..... No.78,East Liuhua Rd, Xiakou Ind. Zone, Dongcheng District,523115, Dongguan,Guangdong, China  
**Factory** ..... Kanen Electronics Co., Ltd  
 Address ..... No.78,East Liuhua Rd, Xiakou Ind. Zone, Dongcheng District,523115, Dongguan,Guangdong, China

**Product description**

Trade Mark: N/A  
 Product name..... Wireless Headphones  
 Model and/or type reference ... M10, K22

**Difference description** All the same except for the model name

**Standards**..... 47 CFR FCC Part 15 Subpart C 15.247

This publication may be reproduced in whole or in part for non-commercial purposes as long as the Shenzhen HUAK Testing Technology Co., Ltd. is acknowledged as copyright owner and source of the material. Shenzhen HUAK Testing Technology Co., Ltd. takes no responsibility for and will not assume liability for damages resulting from the reader's interpretation of the reproduced material due to its placement and context.

**Date of Test**..... :  
 Date (s) of performance of tests ..... : Jan. 16, 2019 ~ Jan. 22, 2019  
 Date of Issue ..... : Jan. 22, 2019  
 Test Result ..... : **Pass**

Testing Engineer : Gary Qian  
 (Gary Qian)

Technical Manager : Eden Hu  
 (Eden Hu)

Authorized Signatory : Jason Zhou  
 (Jason Zhou)

**Table of Contents****Page**

|   |           |
|---|-----------|
| <b>1. SUMMARY .....</b>                                     | <b>4</b>  |
| 1.1. TEST STANDARDS.....                                    | 4         |
| 1.2. TEST DESCRIPTION .....                                 | 4         |
| TEST FACILITY .....   | 5         |
| 1.3. STATEMENT OF THE MEASUREMENT UNCERTAINTY .....         | 5         |
| <b>2. GENERAL INFORMATION .....</b>                         | <b>6</b>  |
| 2.1. ENVIRONMENTAL CONDITIONS .....                         | 6         |
| 2.2. GENERAL DESCRIPTION OF EUT .....                       | 6         |
| 2.3. DESCRIPTION OF TEST MODES AND TEST FREQUENCY .....     | 6         |
| 2.4. RELATED SUBMITTAL(S) / GRANT (S).....                  | 8         |
| 2.5. MODIFICATIONS.....                                     | 8         |
| 2.6. RECEIVER INPUT BANDWIDTH.....                          | 8         |
| 2.7. EXAMPLE OF A HOPPING SEQUENCE IN DATA MODE.....        | 8         |
| 2.8. EQUALLY AVERAGE USE OF FREQUENCIES AND BEHAVIOUR ..... | 8         |
| 2.9. EQUIPMENT USED .....                                   | 9         |
| <b>3. PEAK OUTPUT POWER.....</b>                            | <b>10</b> |
| 3.1. MEASUREMENT PROCEDURE.....                             | 10        |
| 3.2. TEST SET-UP (BLOCK DIAGRAM OF CONFIGURATION).....      | 10        |
| 3.3. LIMITS AND MEASUREMENT RESULT.....                     | 11        |
| <b>4. 20DB BANDWIDTH.....</b>                               | <b>17</b> |
| 4.1. MEASUREMENT PROCEDURE.....                             | 17        |
| 4.2. TEST SET-UP (BLOCK DIAGRAM OF CONFIGURATION).....      | 17        |
| 4.3. LIMITS AND MEASUREMENT RESULTS.....                    | 18        |
| <b>5. CONDUCTED SPURIOUS EMISSION.....</b>                  | <b>24</b> |
| 5.1. MEASUREMENT PROCEDURE.....                             | 24        |
| 5.2. TEST SET-UP (BLOCK DIAGRAM OF CONFIGURATION).....      | 24        |
| 5.3. LIMITS AND MEASUREMENT RESULT.....                     | 24        |
| <b>6. RADIATED EMISSION .....</b>                           | <b>34</b> |
| 6.1. MEASUREMENT PROCEDURE.....                             | 34        |
| 6.2. TEST SETUP.....  | 36        |
| 6.3. LIMITS AND MEASUREMENT RESULT.....                     | 37        |
| <b>7. NUMBER OF HOPPING FREQUENCY .....</b>                 | <b>47</b> |
| 7.1. MEASUREMENT PROCEDURE.....                             | 47        |
| 7.2. TEST SETUP (BLOCK DIAGRAM OF CONFIGURATION) .....      | 47        |
| 7.3. LIMITS AND MEASUREMENT RESULT.....                     | 47        |
| <b>8. TIME OF OCCUPANCY (DWELL TIME).....</b>               | <b>48</b> |
| 8.1. MEASUREMENT PROCEDURE.....                             | 48        |
| 8.2. TEST SETUP (BLOCK DIAGRAM OF CONFIGURATION) .....      | 48        |
| 8.3. LIMITS AND MEASUREMENT RESULT.....                     | 48        |
| <b>9. FREQUENCY SEPARATION .....</b>                        | <b>52</b> |
| 9.1. MEASUREMENT PROCEDURE.....                             | 52        |
| 9.2. TEST SETUP (BLOCK DIAGRAM OF CONFIGURATION) .....      | 52        |
| 9.3. LIMITS AND MEASUREMENT RESULT.....                     | 52        |
| <b>10. TEST SETUP PHOTOS OF THE EUT.....</b>                | <b>53</b> |
| <b>11. PHOTOGRAPH OF EUT .....</b>                          | <b>54</b> |



# 1. SUMMARY

## 1.1. TEST STANDARDS

The tests were performed according to following standards:

**FCC Rules Part 15.247:** Frequency Hopping, Direct Spread Spectrum and Hybrid Systems that are in operation within the bands of 902-928 MHz, 2400-2483.5 MHz, and 5725-5850 MHz

**ANSI C63.10:2013** : American National Standard for Testing Unlicensed Wireless Devices

## 1.2. Test Description

| FCC PART 15.247            |  |      |
|----------------------------|--|------|
| FCC Part 15.207            | AC Power Conducted Emission                    | N/A  |
| FCC Part 15.247(a)(1)(i)   | 20dB Bandwidth                                 | PASS |
| FCC Part 15.247(d)         | Spurious RF Conducted Emission                 | PASS |
| FCC Part 15.247(b)         | Maximum Peak Output Power                      | PASS |
| FCC Part 15.247(b)         | Pseudorandom Frequency Hopping Sequence        | PASS |
| FCC Part 15.247(a)(1)(iii) | Number of hopping frequency& Time of Occupancy | PASS |
| FCC Part 15.247(a)(1)      | Frequency Separation                           | PASS |
| FCC Part 15.205/15.209     | Radiated Emissions                             | PASS |
| FCC Part 15.247(d)         | Band Edge Compliance of RF Emission            | PASS |

NOTE: N/A stands for not applicable. The device can not use the BT function in charging mode.



## Test Facility

### 1.3.1 Address of the test laboratory

Shenzhen HUAKE Testing Technology Co., Ltd.  
Add.:1F, B2 Building, Junfeng Zhongcheng Zhizao Innovation Park,Heping Community, Fuhai Street, Bao'an District, Shenzhen, China

There is one 3m semi-anechoic chamber and two line conducted labs for final test. The Test Sites meet the requirements in documents ANSI C63.4 and CISPR 32/EN 55032 requirements.

### 1.3.2 Laboratory accreditation

The test facility is recognized, certified, or accredited by the following organizations:

#### IC Registration No.: 21210

The 3m alternate test site of Shenzhen HUAKE Testing Technology Co., Ltd. EMC Laboratory has been registered by Certification and Engineer Bureau of Industry Canada for the performance of with Registration No.: 21210 on May 24, 2016.

#### FCC Registration No.: CN1229

Test Firm Registration Number : 616276

## 1.3. Statement of the measurement uncertainty

The data and results referenced in this document are true and accurate. The reader is cautioned that there may be errors within the calibration limits of the equipment and facilities. The measurement uncertainty was calculated for all measurements listed in this test report acc. to CISPR 16 - 4 "Specification for radio disturbance and immunity measuring apparatus and methods – Part 4: Uncertainty in EMC Measurements" and is documented in the Shenzhen HUAKE Testing Technology Co., Ltd. quality system acc. to DIN EN ISO/IEC 17025. Furthermore, component and process variability of devices similar to that tested may result in additional deviation. The manufacturer has the sole responsibility of continued compliance of the device.

Hereafter the best measurement capability for HUAKE laboratory is reported:

| Test                                    | Measurement Uncertainty | Notes |
|---|-------------------------|-------|
| Transmitter power conducted             | ±0.57 dB                | (1)   |
| Transmitter power Radiated              | ±2.20 dB                | (1)   |
| Conducted spurious emission 9KHz-40 GHz | ±2.20 dB                | (1)   |
| Occupied Bandwidth                      | ±0.01ppm                | (1)   |
| Radiated Emission 30~1000MHz            | ±4.10dB                 | (1)   |
| Radiated Emission Above 1GHz            | ±4.32dB                 | (1)   |
| Conducted Disturbance0.15~30MHz         | ±3.20dB                 | (1)   |

(1) This uncertainty represents an expanded uncertainty expressed at approximately the 95% confidence level using a coverage factor of k=2.



## 2. GENERAL INFORMATION

### 2.1. Environmental conditions

During the measurement the environmental conditions were within the listed ranges:

|                     |         |
|---------------------|---------|
| Normal Temperature: | 25°C    |
| Relative Humidity:  | 55 %    |
| Air Pressure:       | 101 kPa |

### 2.2. General Description of EUT

|                       |                            |
|-----------------------|----------------------------|
| Product Name:         | Wireless Headphones        |
| Model/Type reference: | M10                        |
| Power supply:         | DC 3.7V, 300mAh by Battery |
| Version:              | V4.2                       |
| Modulation:           | GFSK, $\pi/4$ DQPSK, 8DPSK |
| Operation frequency:  | 2402MHz~2480MHz            |
| Channel number:       | 79                         |
| Channel separation:   | 1MHz                       |
| Antenna type:         | PCB Antenna                |
| Antenna gain:         | 0dBi                       |
| Hardware Version:     | 2.0                        |
| Software Version:     | 4.2                        |

Note:1. For more details, refer to the user's manual of the EUT.

2.The product only supports BR and EDR,but does not support BLE.

### 2.3. Description of Test Modes and Test Frequency

The Applicant provides communication tools software to control the EUT for staying in continuous transmitting and receiving mode for testing.

There are 79 channels provided to the EUT and Channel 00/39/78 was selected for testing.

#### Operation Frequency :

| Channel | Frequency (MHz) |
|---------|-----------------|
| 00      | 2402            |
| 01      | 2403            |
| :       | :               |
| 38      | 2440            |
| 39      | 2441            |
| 40      | 2442            |
| :       | :               |
| 77      | 2479            |
| 78      | 2480            |

Note: The line display in grey were the channel selected for testing



| NO. | TEST MODE DESCRIPTION |
|-----|-----------------------|
| 1   | Low channel TX        |
| 2   | Middle channel TX     |
| 3   | High channel TX       |
| 4   | Normal Operating (BT) |

Note:

1. Only the result of the worst case was recorded in the report, if no other cases.
2. For Radiated Emission, 3axis were chosen for testing for each applicable mode.



## 2.4. Related Submittal(s) / Grant (s)

This submittal(s) (test report) is intended to comply with Section 15.247 of the FCC Part 15, Subpart C Rules.

## 2.5. Modifications

No modifications were implemented to meet testing criteria.

## 2.6. Receiver Input Bandwidth

The input bandwidth of the receiver is 1.3MHz. In every connection one Bluetooth device is the master and the other one is slave. The master determines the hopping sequence. The slave follows this sequence. Both devices shift between RX and TX time slot according to the clock of the master. Additionally the type of connection (e.g. single or multislotted packet) is set up at the beginning of the connection. The master adapts its hopping frequency and its TX/RX timing according to the packet type of the connection. Also the slave of the connection will use these settings.

Repeating of a packet has no influence on the hopping sequence. The hopping sequence generated by the master of the connection will be followed in any case. That means, a repeated packet will not be sent on the same frequency, it is sent on the next frequency of the hopping sequence.

## 2.7. Example of a Hopping Sequence in Data Mode

Example of a 79 hopping sequence in data mode:

40,21,44,23,42,53,46,55,48,33,52,35,50,65,54,67  
56,37,60,39,58,69,62,71,64,25,68,27,66,57,70,59  
72,29,76,31,74,61,78,63,01,41,05,43,03,73,07,75  
09,45,13,47,11,77,15,00,64,49,66,53,68,02,70,06  
01, 51, 03, 55, 05, 04

## 2.8. Equally Average Use of Frequencies and Behaviour

The generation of the hopping sequence in connection mode depends essentially on two input values:

1. LAP/UAP of the master of the connection.
2. Internal master clock

The LAP (lower address part) are the 24 LSB's of the 48 BD\_ADDRESS. The BD\_ADDRESS is an unambiguous number of every Bluetooth unit. The UAP (upper address part) are the 24 MSB's of the 48 BD\_ADDRESS.

The internal clock of a Bluetooth unit is derived from a free running clock which is never adjusted and is never turned off. For synchronization with other units only offsets are used. It has no relation to the time of the day. Its resolution is at least half the RX/TX slot length of 312.5us. The clock has a cycle of about one day (23h30). In most cases it is implemented as a 28-bit counter. For the deriving of the hopping sequence the entire LAP (24 bits), 4 LSB's (4 bits) (Input 1) and the 27 MSB's of the clock (Input 2) are used. With these input values different mathematical procedures (permutations, additions, XOR-operations) are performed to generate the sequence. This will be done at the beginning of every new transmission.

Regarding short transmissions the Bluetooth system has the following behavior:

The first connection between the two devices is established, a hopping sequence was generated. For transmitting the wanted data the complete hopping sequence was not used. The connection ended.

The second connection will be established. A new hopping sequence is generated. Due to the fact the Bluetooth clock has a different value, because the period between the two transmissions is longer (and it cannot be shorter) than the minimum resolution of the clock (312.5us). The hopping sequence will always differ from the first one.





## 2.9. Equipment Used

| Item | Equipment                               | Manufacturer    | Model No.           | Serial No. | Last Cal.     | Cal. Interval |
|------|---|-----------------|---------------------|------------|---------------|---------------|
| 1.   | L.I.S.N.<br>Artificial Mains<br>Network | R&S             | ENV216              | HKE-002    | Dec. 27, 2018 | 1 Year        |
| 2.   | Receiver                                | R&S             | ESCI 7              | HKE-010    | Dec. 27, 2018 | 1 Year        |
| 3.   | RF automatic<br>control unit            | Tonscend        | JS0806-2            | HKE-060    | Dec. 27, 2018 | 1 Year        |
| 4.   | Horn Antenna                            | Schwarzbeck     | BBHA 9170           | HKE-090    | Dec. 27, 2018 | 1 Year        |
| 5.   | Spectrum analyzer                       | Agilent         | N9020A              | HKE-048    | Dec. 27, 2018 | 1 Year        |
| 6.   | Preamplifier                            | Schwarzbeck     | BBV 9743            | HKE-006    | Dec. 27, 2018 | 1 Year        |
| 7.   | EMI Test Receiver                       | Rohde & Schwarz | ESCI 7              | HKE-010    | Dec. 27, 2018 | 1 Year        |
| 8.   | Bilog Broadband<br>Antenna              | Schwarzbeck     | VULB9163            | HKE-012    | Dec. 27, 2018 | 1 Year        |
| 9.   | Loop Antenna                            | Schwarzbeck     | FMZB 1519<br>B      | HKE-014    | Dec. 27, 2018 | 1 Year        |
| 10.  | Horn Antenna                            | Schwarzbeck     | 9120D               | HKE-013    | Dec. 27, 2018 | 1 Year        |
| 11.  | Pre-amplifier                           | EMCI            | EMC051845<br>SE     | HKE-015    | Dec. 27, 2018 | 1 Year        |
| 12.  | Pre-amplifier                           | Agilent         | 83051A              | HKE-016    | Dec. 27, 2018 | 1 Year        |
| 13.  | EMI Test Software<br>EZ-EMC             | Tonscend        | JS1120-B<br>Version | HKE-083    | Dec. 27, 2018 | N/A           |
| 14.  | Shielded room                           | Shiel Hong      | 4*3*3               | HKE-039    | Dec. 27, 2018 | 3 Year        |

The calibration interval was one year



### 3. Peak Output Power

#### 3.1. Measurement Procedure

For peak power test:

1. Connect EUT RF output port to the Spectrum Analyzer through an RF attenuator
2. Span: Approximately five times the 20 dB bandwidth, centered on a hopping channel.
3. RBW > 20 dB bandwidth of the emission being measured.
4. VBW  $\geq$  RBW.
5. Sweep: Auto.
6. Detector function: Peak.
7. Trace: Max hold.

Allow trace to stabilize. Use the marker-to-peak function to set the marker to the peak of the emission. The indicated level is the peak output power, after any corrections for external attenuators and cables.

#### 3.2. Test Set-Up (Block Diagram of Configuration)

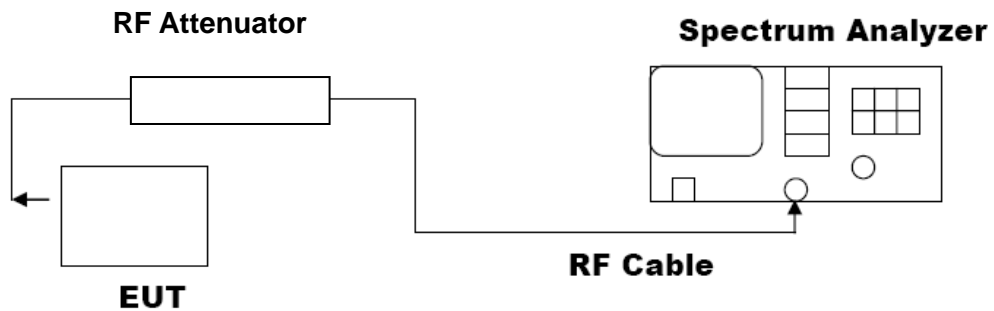



### 3.3. Limits and Measurement Result

| PEAK OUTPUT POWER MEASUREMENT RESULT<br>FOR GFSK MOUDULATION |                  |                         |              |
|--|------------------|-------------------------|--------------|
| Frequency (GHz)  | Peak Power (dBm) | Applicable Limits (dBm) | Pass or Fail |
| 2.402  | 1.208            | 30                      | Pass         |
| 2.441  | 1.206            | 30                      | Pass         |
| 2.480  | 0.555            | 30                      | Pass         |

CH0

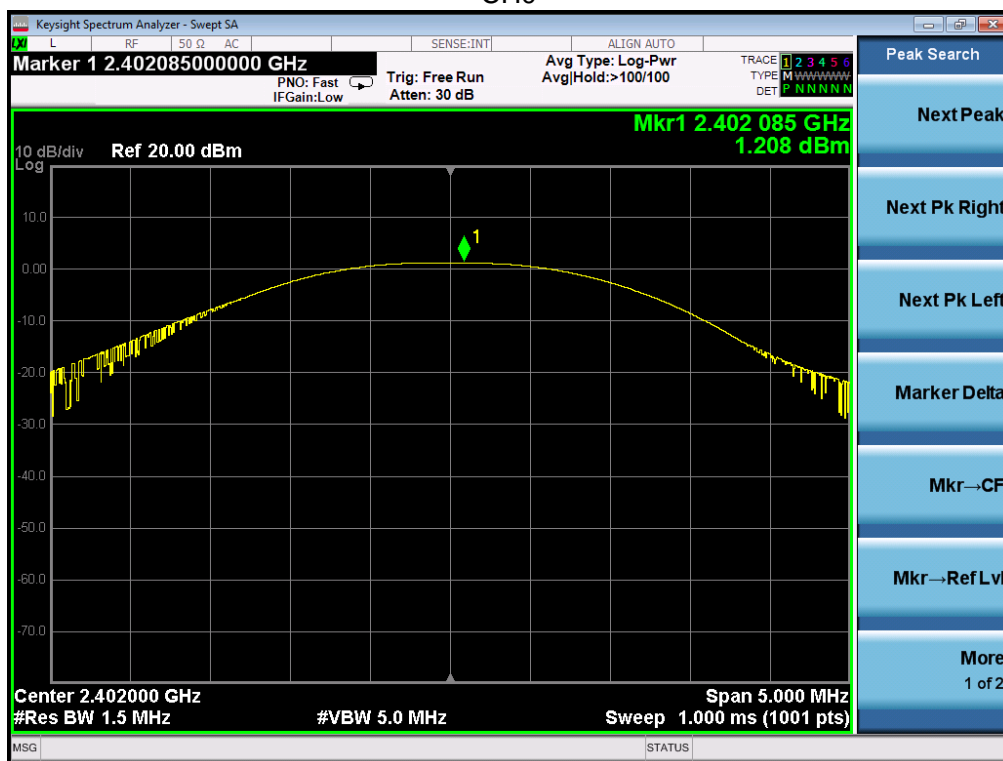



CH39



CH78

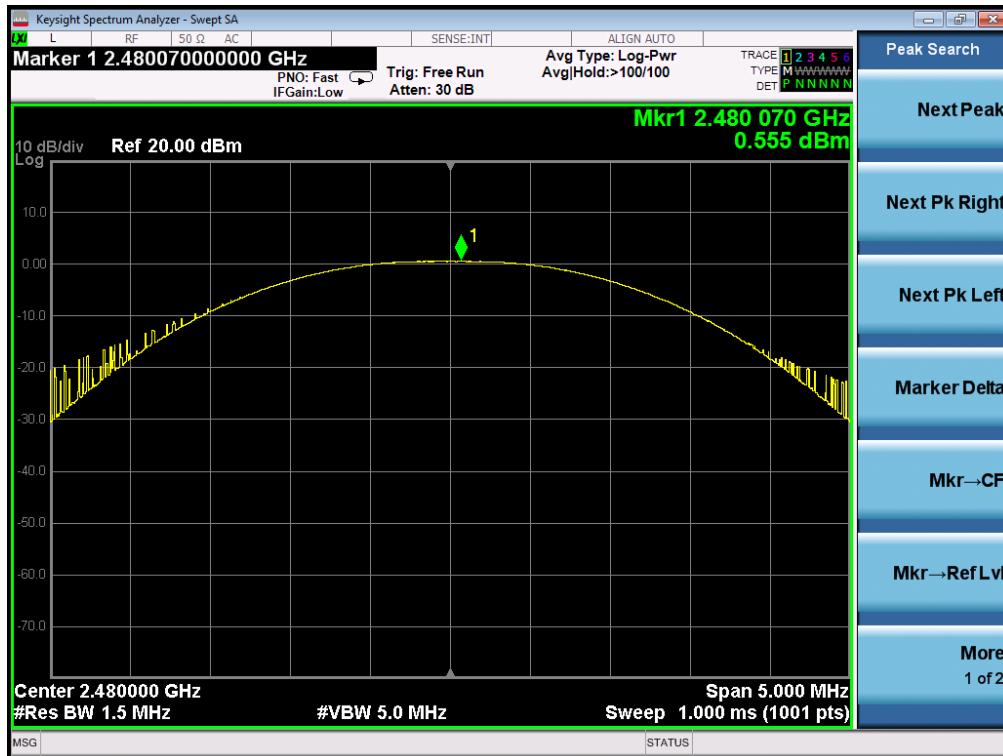



| PEAK OUTPUT POWER MEASUREMENT RESULT<br>FOR $\pi/4$ -DQPSK MODULATION |                  |                         |              |
|---|------------------|-------------------------|--------------|
| Frequency (GHz)   | Peak Power (dBm) | Applicable Limits (dBm) | Pass or Fail |
| 2.402   | 1.632            | 30                      | Pass         |
| 2.441   | 1.674            | 30                      | Pass         |
| 2.480   | 1.000            | 30                      | Pass         |

CH0

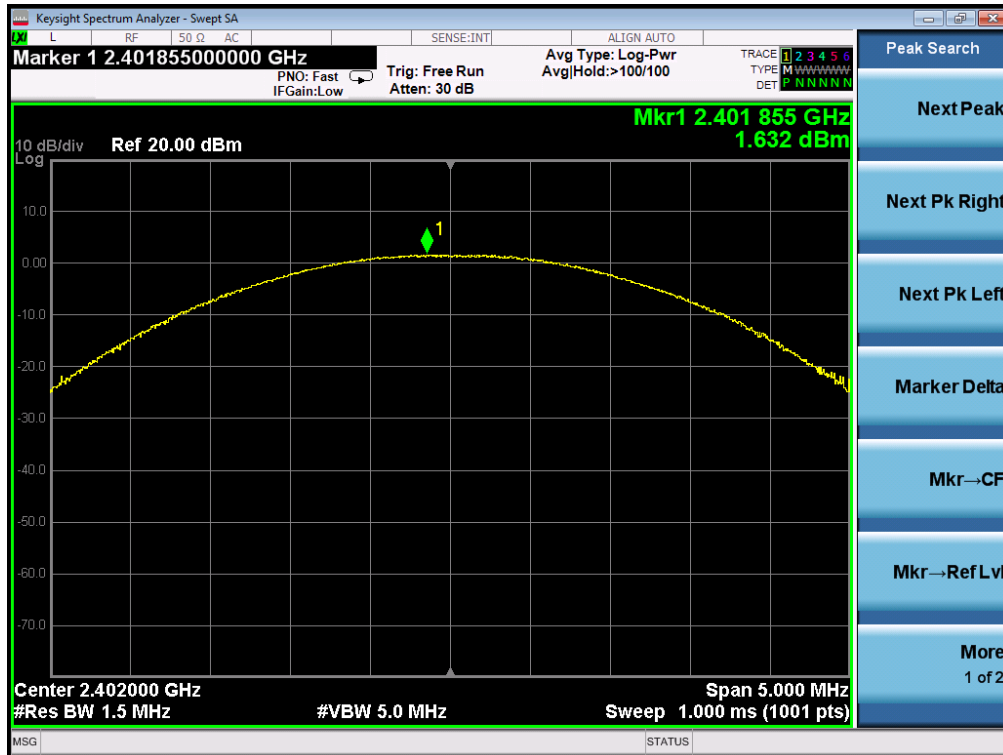



### CH39

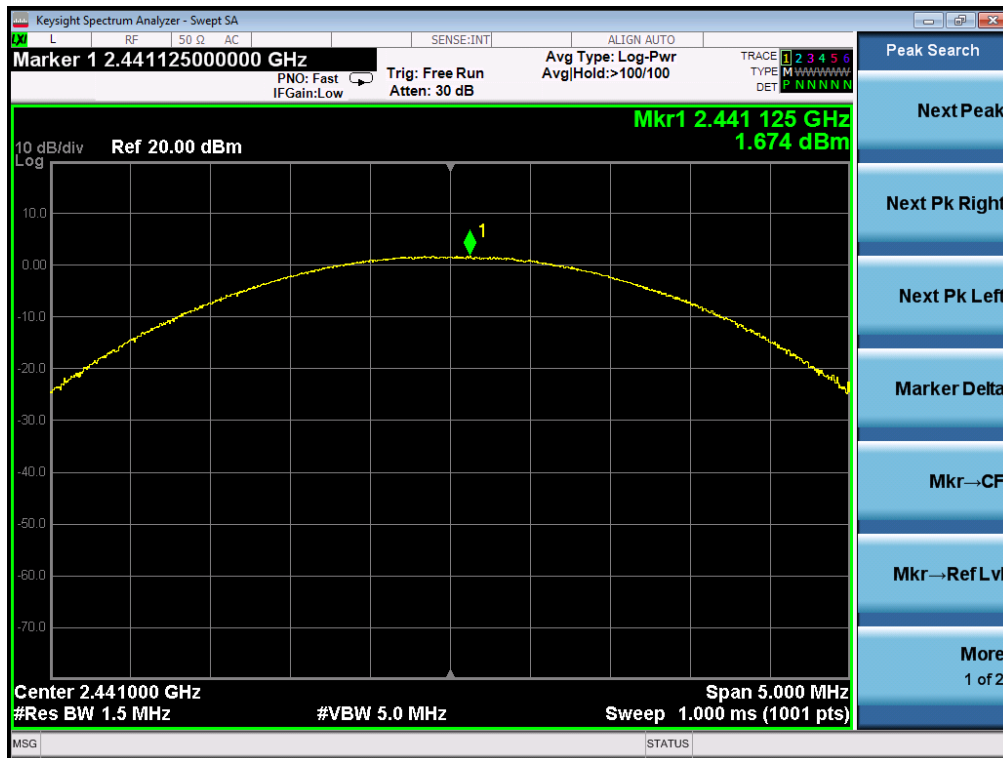

### CH78

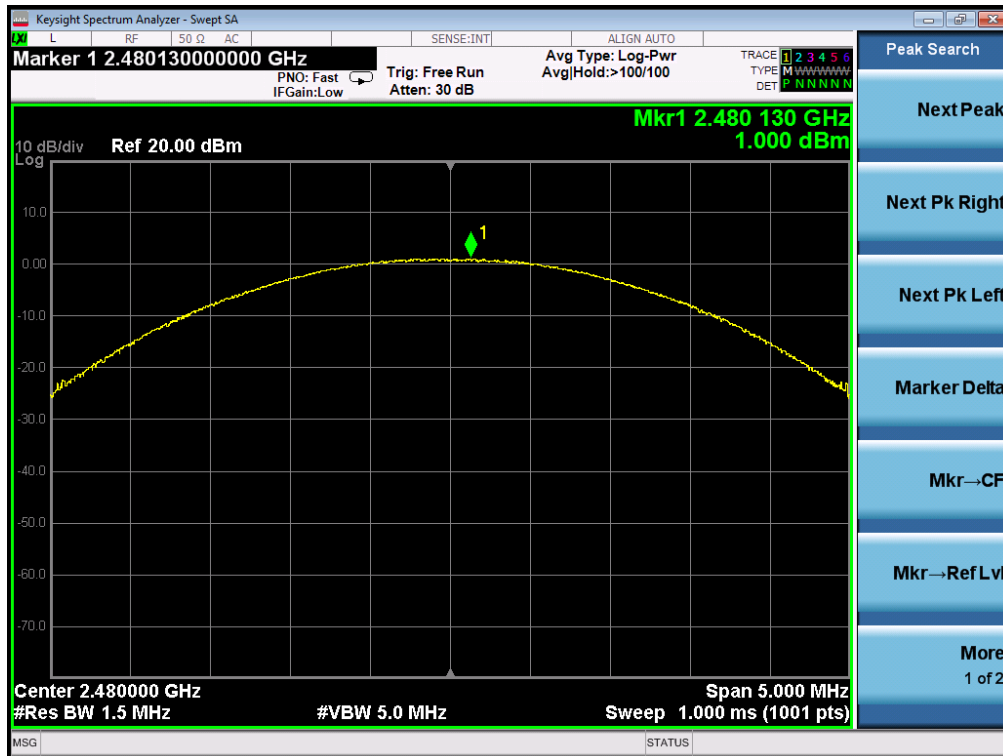



| PEAK OUTPUT POWER MEASUREMENT RESULT<br>FOR 8-DPSK MODULATION |                  |                         |              |
|---|------------------|-------------------------|--------------|
| Frequency (GHz)   | Peak Power (dBm) | Applicable Limits (dBm) | Pass or Fail |
| 2.402   | 1.949            | 30                      | Pass         |
| 2.441   | 1.983            | 30                      | Pass         |
| 2.480   | 1.328            | 30                      | Pass         |

CH0

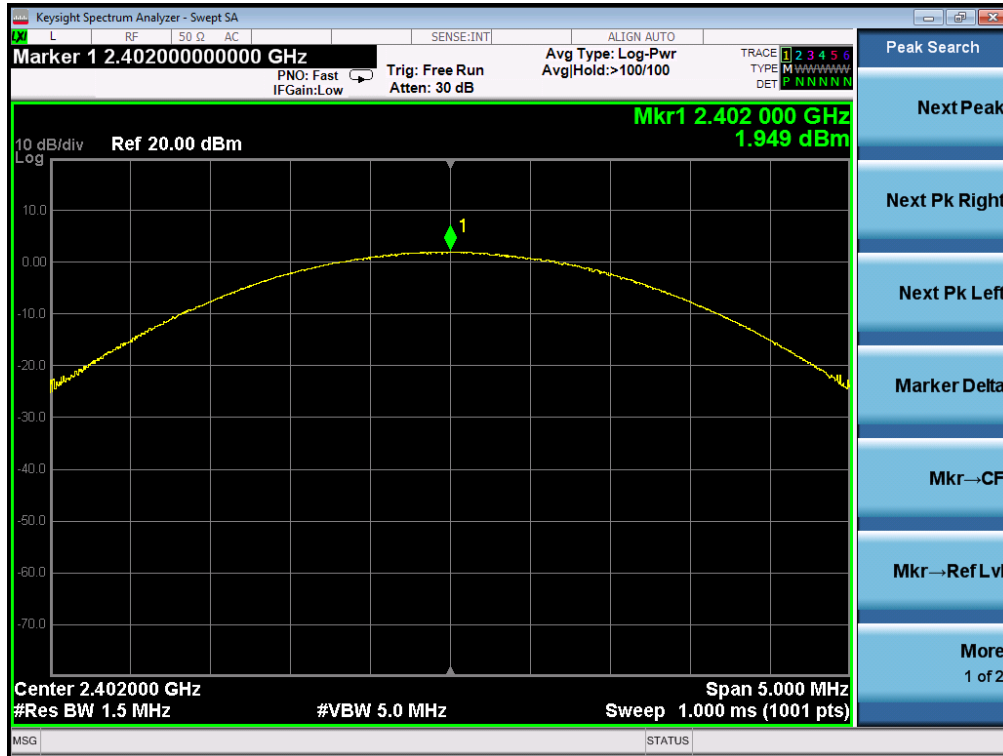



CH39

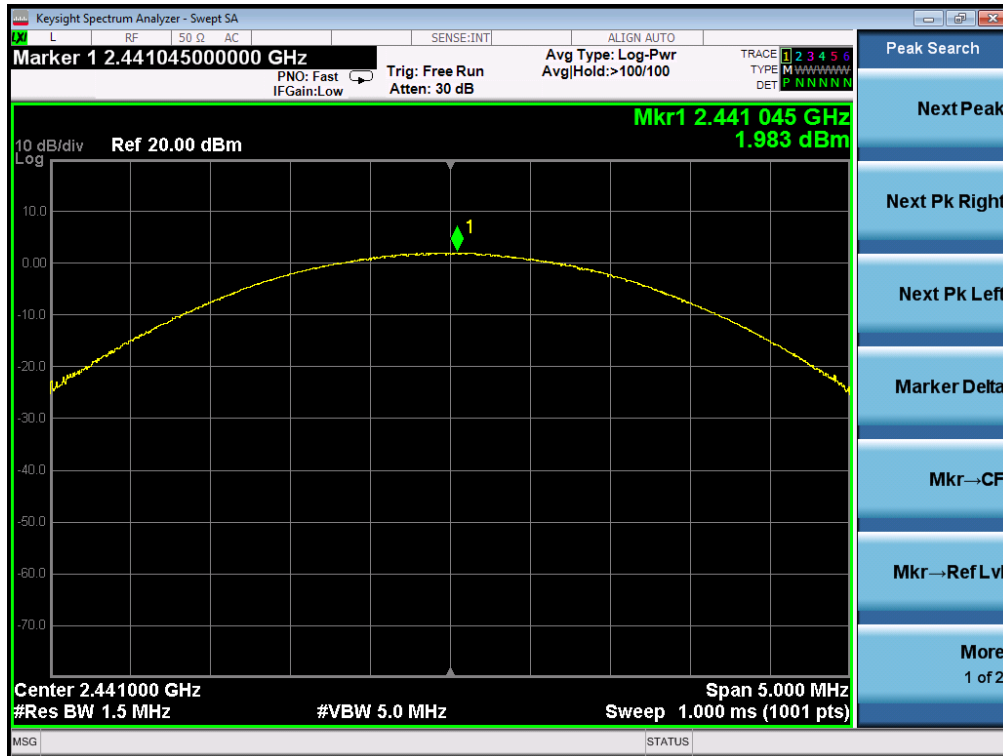

CH78

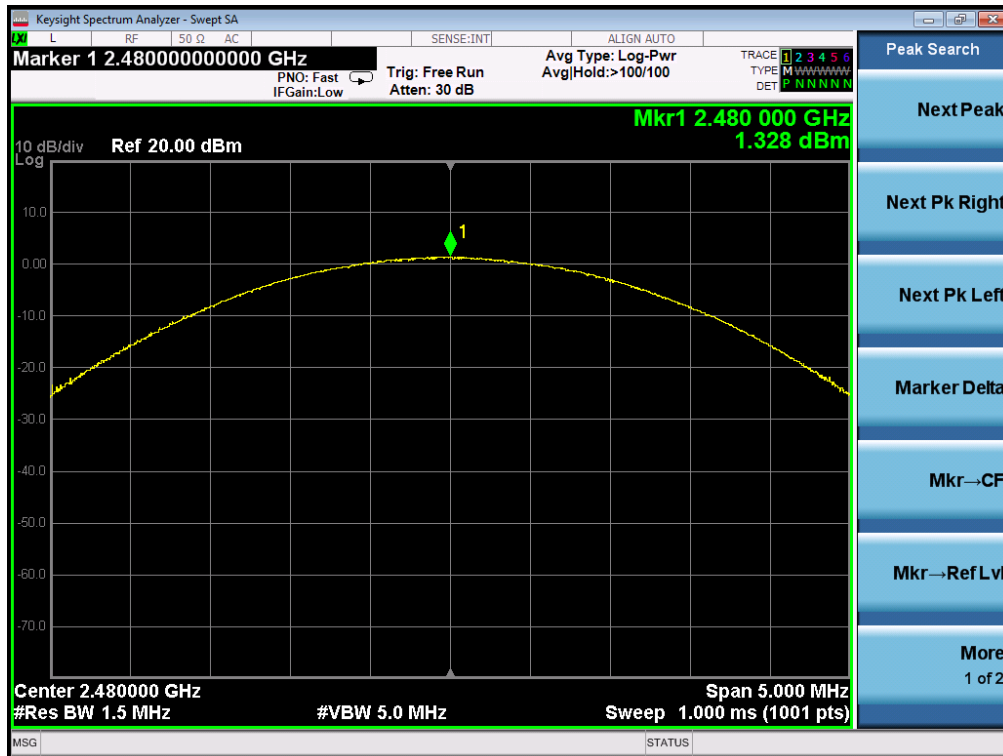



## 4. 20dB Bandwidth

### 4.1. Measurement Procedure

1. Connect EUT RF output port to the Spectrum Analyzer through an RF attenuator
2. Set the EUT Work on the top, the middle and the bottom operation frequency individually.
3. Set Span = approximately 2 to 5 times the 20 dB bandwidth, centered on a hopping channel  
The nominal IF filter bandwidth (3 dB RBW) shall be in the range of 1% to 5% of the OBW and video bandwidth (VBW) shall be approximately three times RBW; Sweep = auto; Detector function = peak
4. Set SPA Trace 1 Max hold, then View.

### 4.2. Test Set-Up (Block Diagram of Configuration)

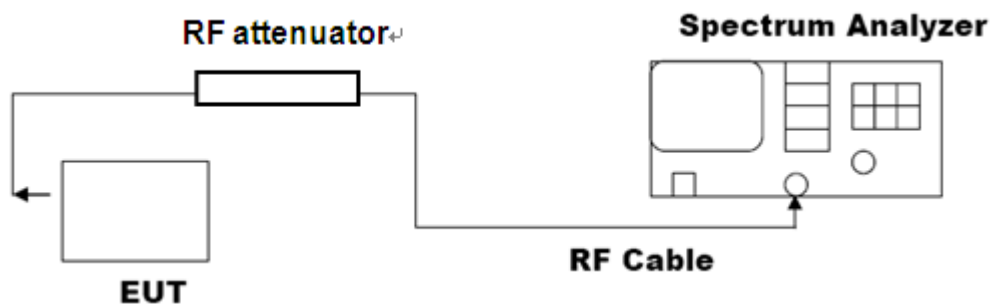



### 4.3. Limits and Measurement Results

| MEASUREMENT RESULT FOR GFSK MODULATION |                    |       |          |
|--|--------------------|-------|----------|
| Applicable Limits                      | Measurement Result |       |          |
|  | Test Data (MHz)    |       | Criteria |
| N/A                                    | Low Channel        | 1.037 | PASS     |
|  | Middle Channel     | 1.030 | PASS     |
|  | High Channel       | 1.037 | PASS     |

TEST PLOT OF BANDWIDTH FOR LOW CHANNEL

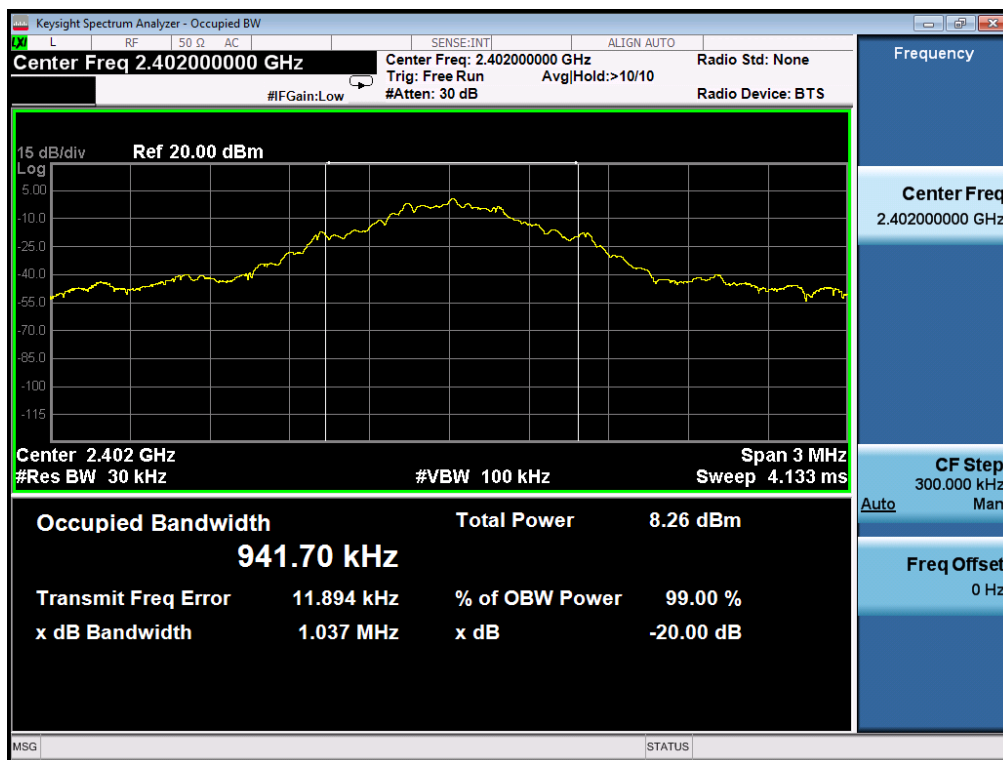



### TEST PLOT OF BANDWIDTH FOR MIDDLE CHANNEL

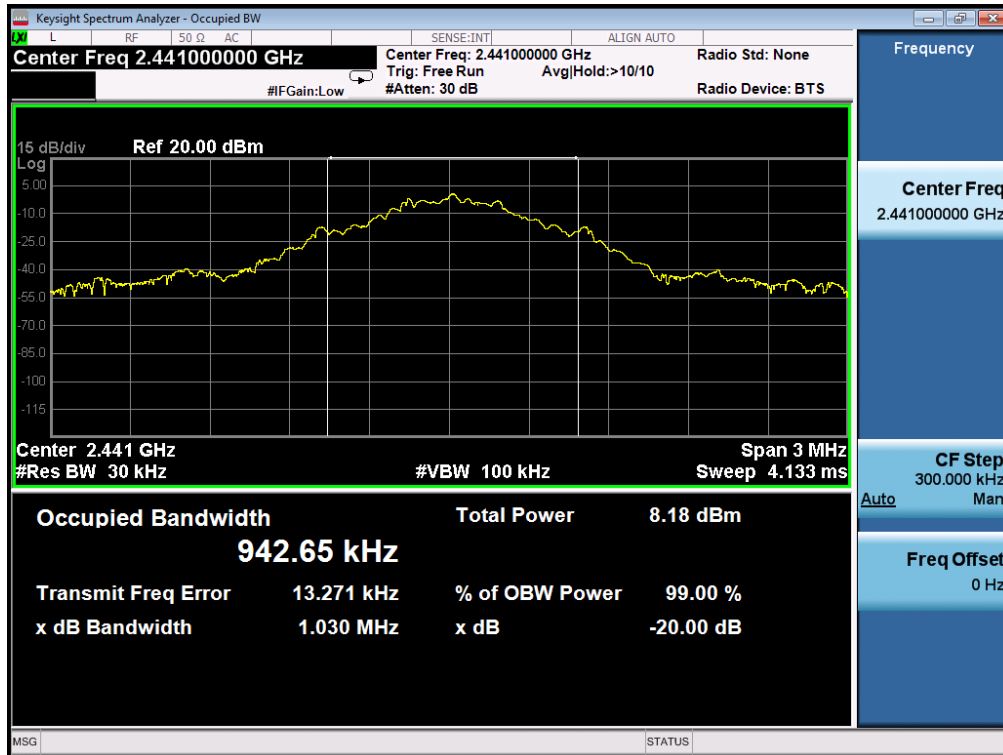

### TEST PLOT OF BANDWIDTH FOR HIGH CHANNEL

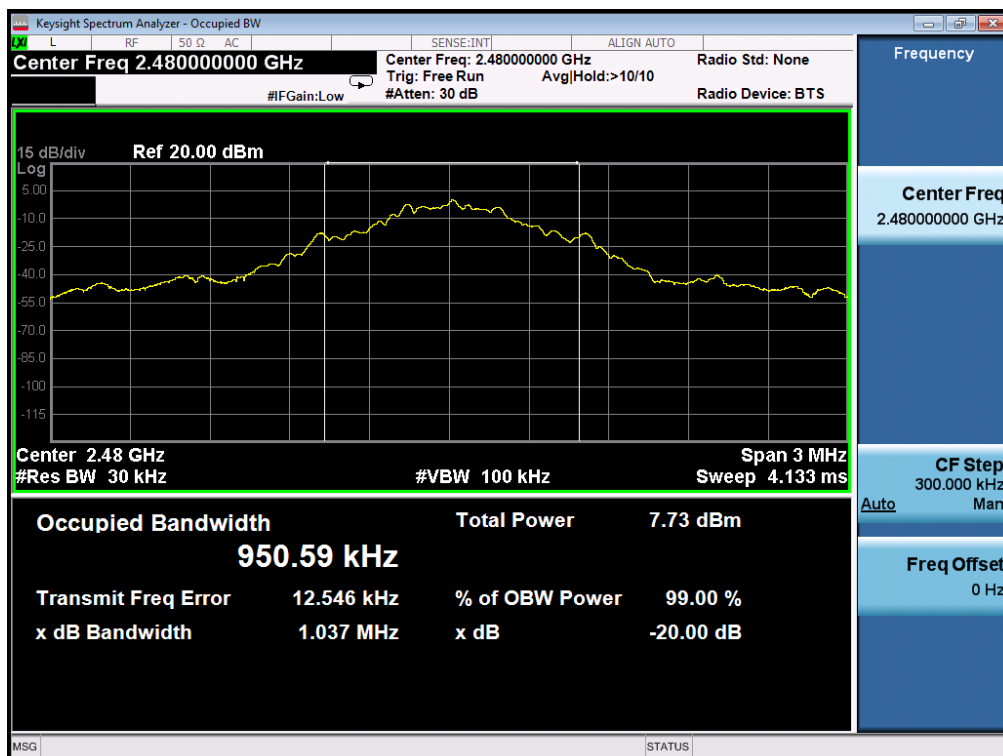



| MEASUREMENT RESULT FOR $\Pi$ /4-DQPSK MODULATION |                    |       |          |
|--|--------------------|-------|----------|
| Applicable Limits                                | Measurement Result |       |          |
|  | Test Data (MHz)    |       | Criteria |
| N/A  | Low Channel        | 1.182 | PASS     |
|  | Middle Channel     | 1.188 | PASS     |
|  | High Channel       | 1.183 | PASS     |

TEST PLOT OF BANDWIDTH FOR LOW CHANNEL

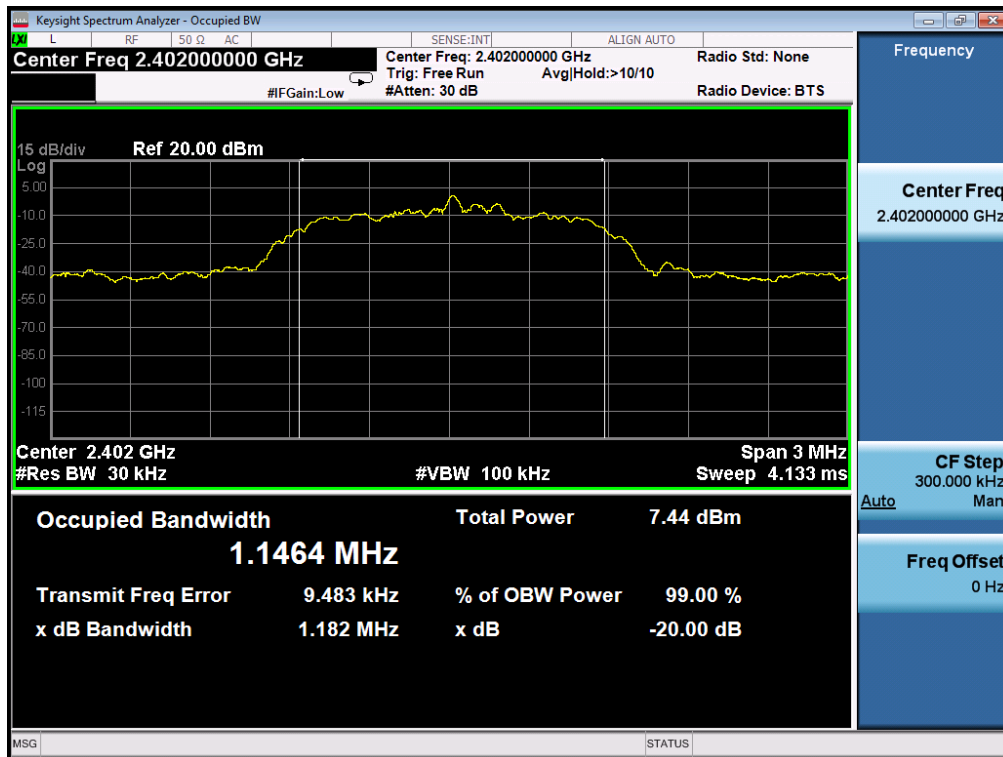



### TEST PLOT OF BANDWIDTH FOR MIDDLE CHANNEL

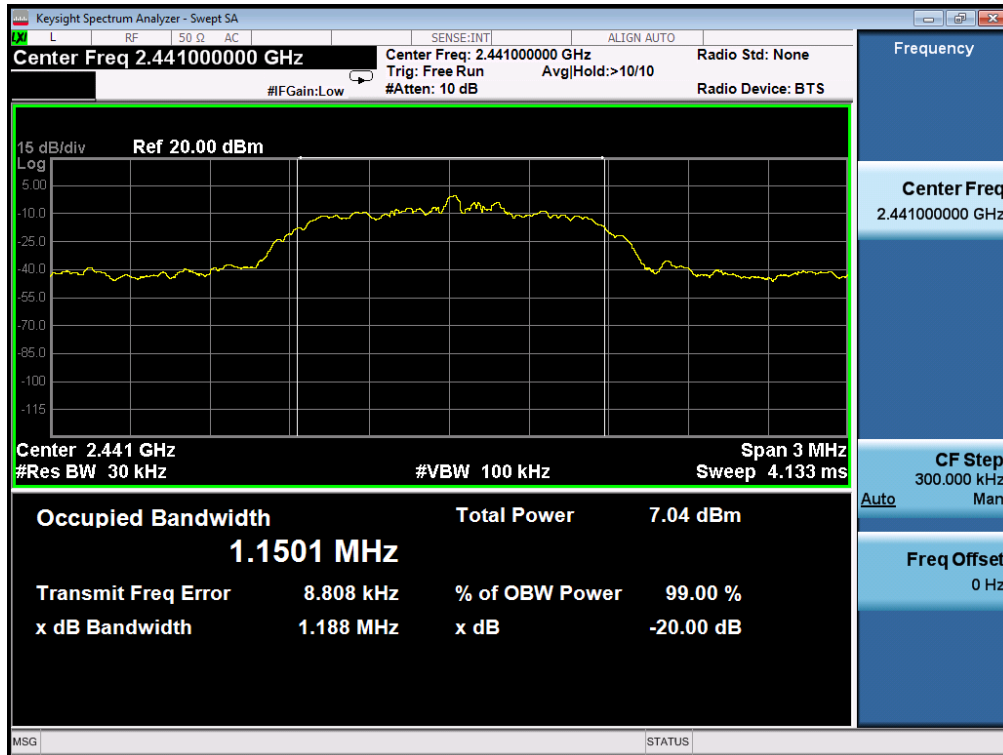

### TEST PLOT OF BANDWIDTH FOR HIGH CHANNEL





| MEASUREMENT RESULT FOR 8-DPSK MODULATION |                    |       |          |
|--|--------------------|-------|----------|
| Applicable Limits                        | Measurement Result |       |          |
|  | Test Data (MHz)    |       | Criteria |
| N/A                                      | Low Channel        | 1.193 | PASS     |
|  | Middle Channel     | 1.194 | PASS     |
|  | High Channel       | 1.191 | PASS     |

TEST PLOT OF BANDWIDTH FOR LOW CHANNEL

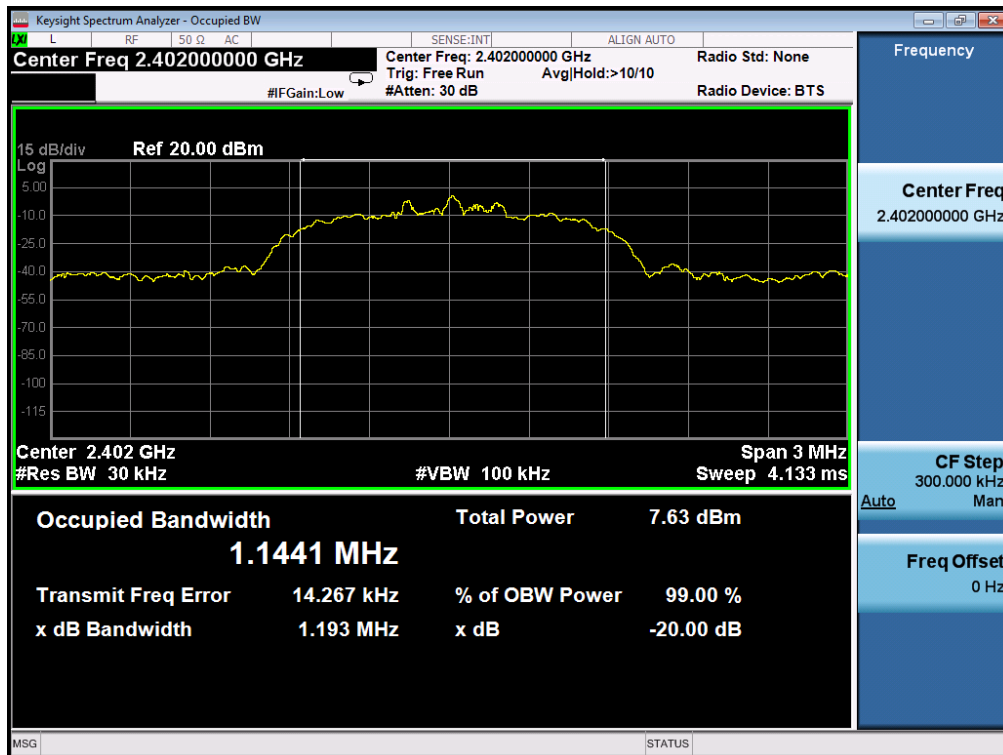



### TEST PLOT OF BANDWIDTH FOR MIDDLE CHANNEL

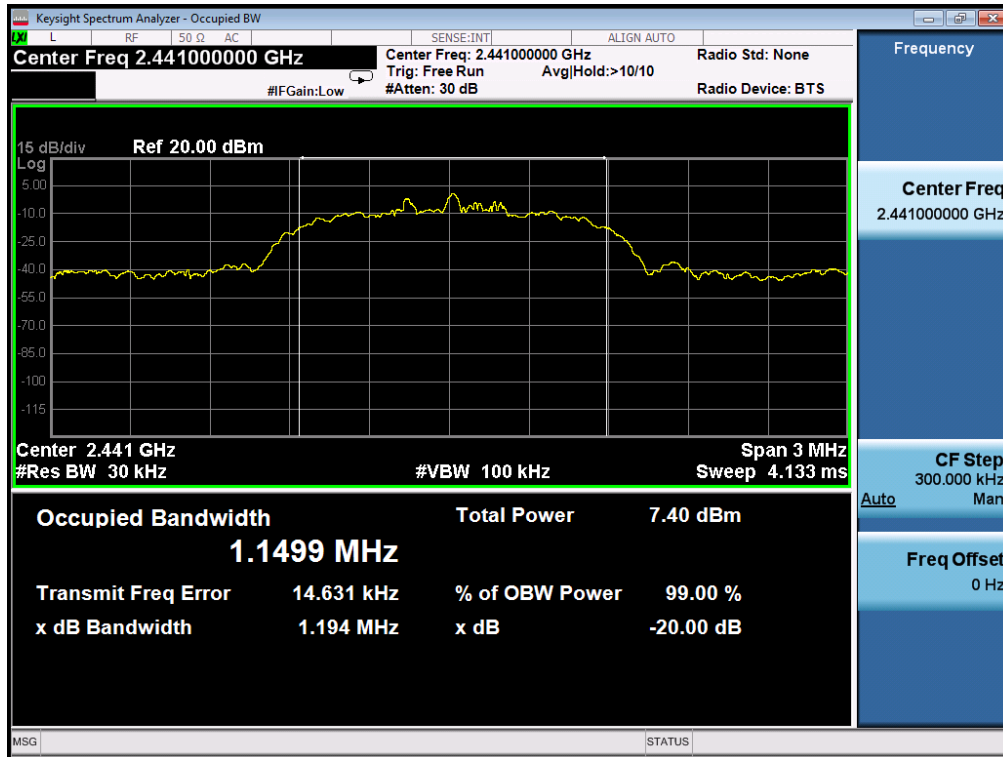

### TEST PLOT OF BANDWIDTH FOR HIGH CHANNEL

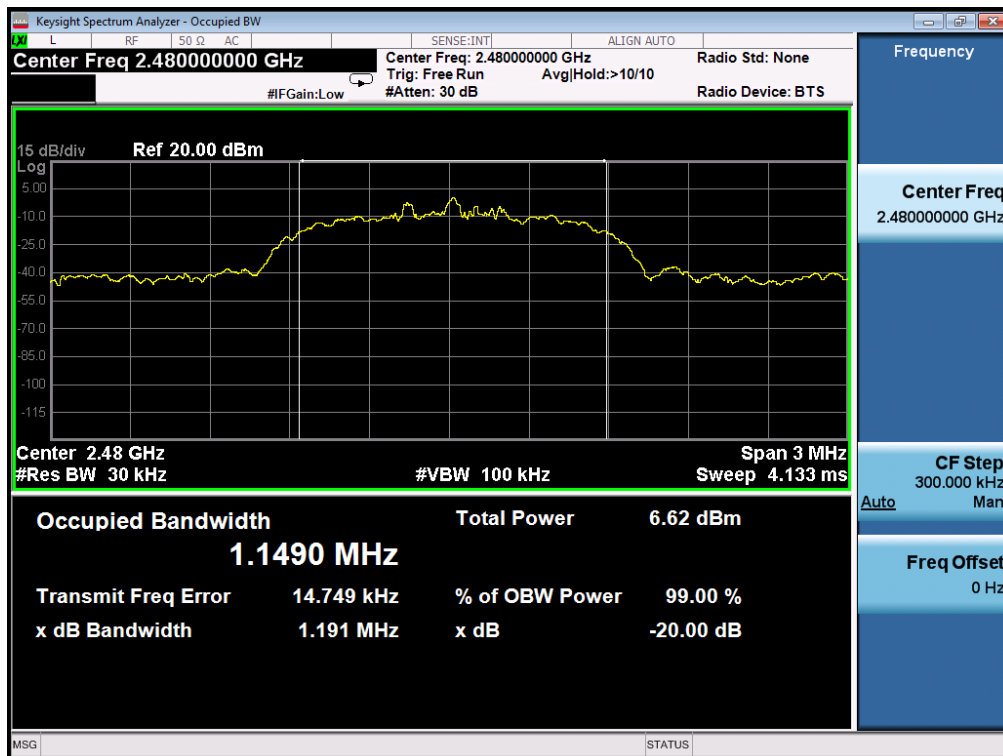



## 5. Conducted Spurious Emission

### 5.1. Measurement Procedure

1. Connect EUT RF output port to the Spectrum Analyzer through an RF attenuator
2. Set the EUT Work on the top, the Middle and the bottom operation frequency individually.
3. Set the Span = wide enough to capture the peak level of the in-band emission and all spurious emissions from the lowest frequency generated in the EUT up through the 10th harmonic.  
RBW = 100 kHz; VBW= 300 kHz; Sweep = auto; Detector function = peak.
4. Set SPA Trace 1 Max hold, then View.

### 5.2. Test Set-Up (Block Diagram of Configuration)

The same as described in section 4.2

### 5.3. Limits and Measurement Result

| LIMITS AND MEASUREMENT RESULT  |  |          |
|--|--|----------|
| Applicable Limits  | Measurement Result   |          |
|  | Test Data  | Criteria |
| In any 100 KHz Bandwidth Outside the frequency band in which the spread spectrum intentional radiator is operating, the radio frequency power that is produce by the intentional radiator shall be at least 20 dB below that in 100KHz bandwidth within the band that contains the highest level of the desired power.<br>In addition, radiation emissions which fall in the restricted bands, as defined in §15.205(a), must also comply with the radiated emission limits specified in§15.209(a) | At least -20dBc than the limit Specified on the BOTTOM Channel | PASS     |
|  | At least -20dBc than the limit Specified on the TOP Channel    | PASS     |









### TEST PLOT OF OUT OF BAND EMISSIONS OF GFSK MODULATION IN HIGH CHANNEL

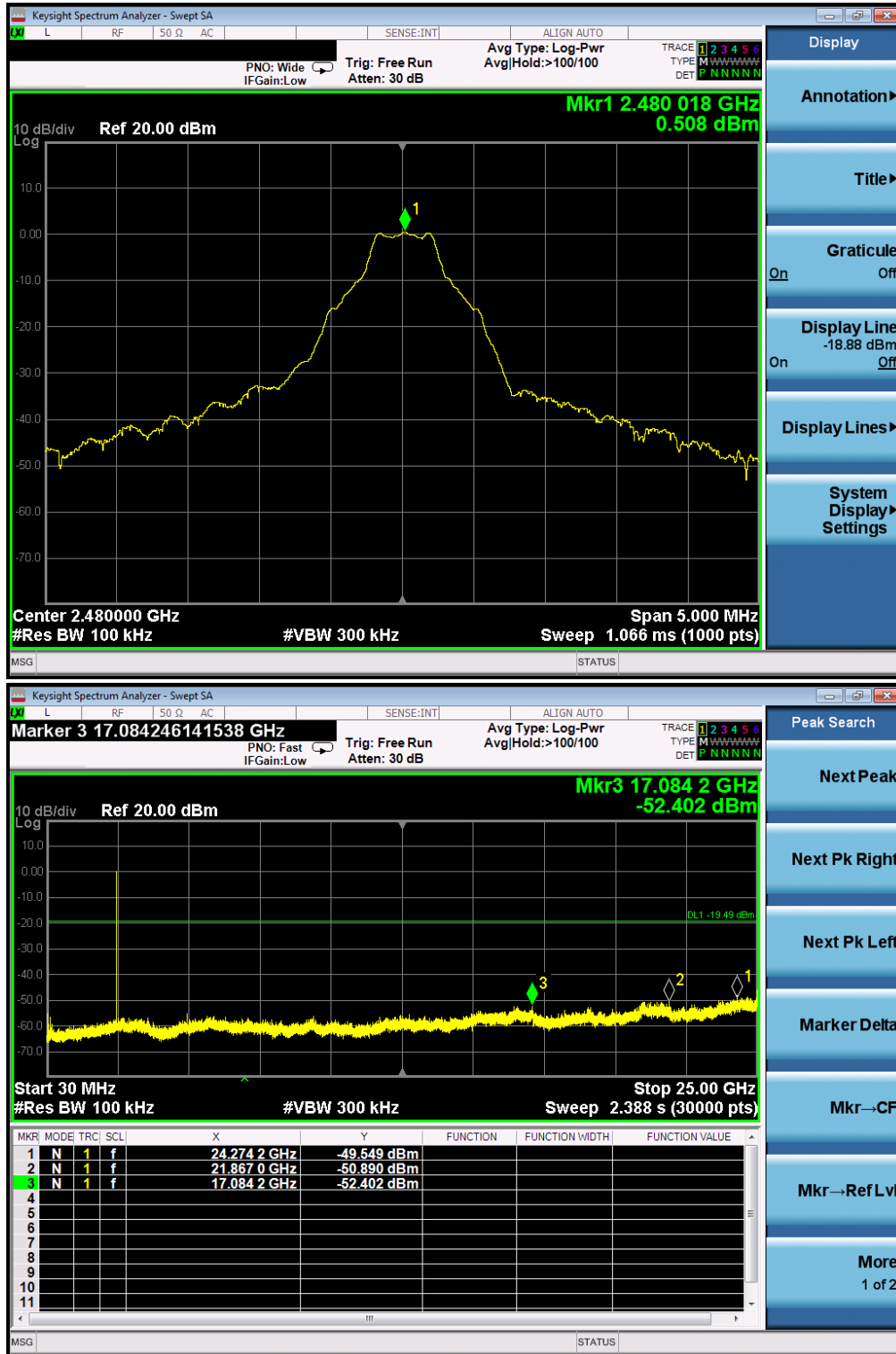

Note: The peak emissions without marker on the above plots are fundamental wave and need not to compare with the limit. The GFSK modulation is the worst case and only those data recorded in the report.





### GFSK MODULATION IN HIGH CHANNEL Hopping off

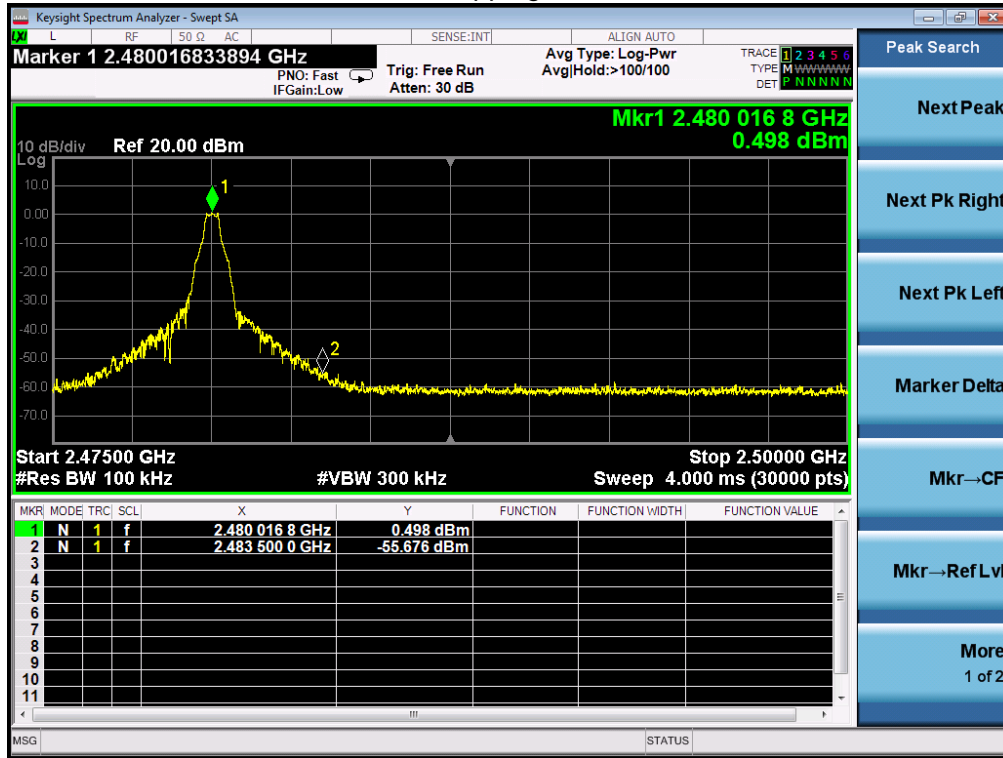

### Hopping on

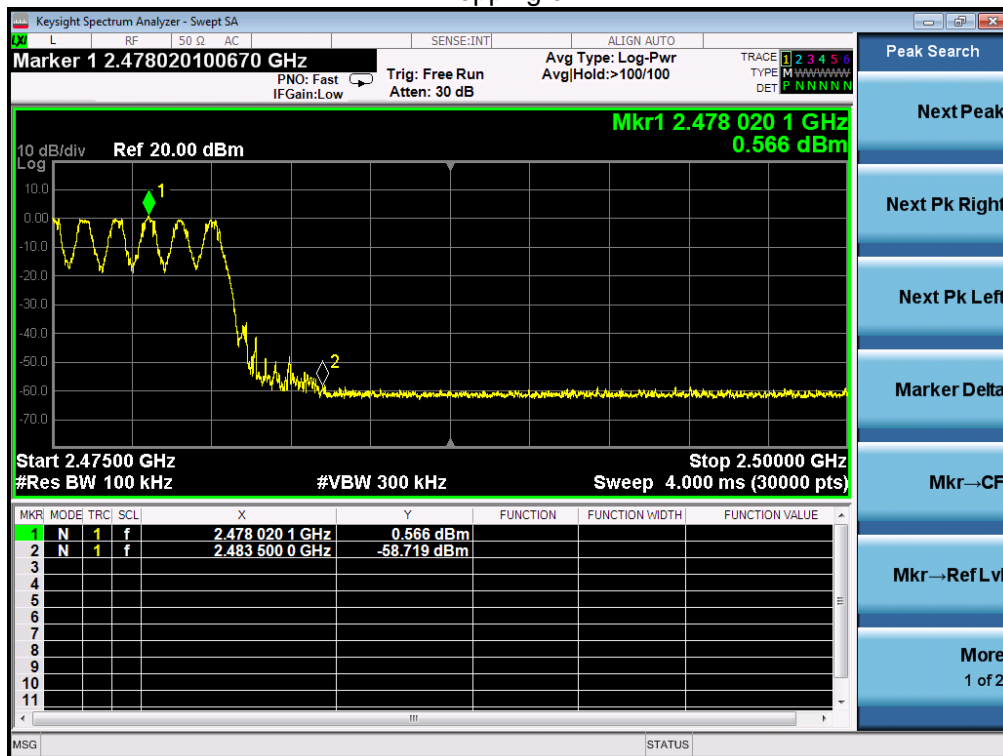



### $\pi$ /4-DQPSK MODULATION IN LOW CHANNEL Hopping off

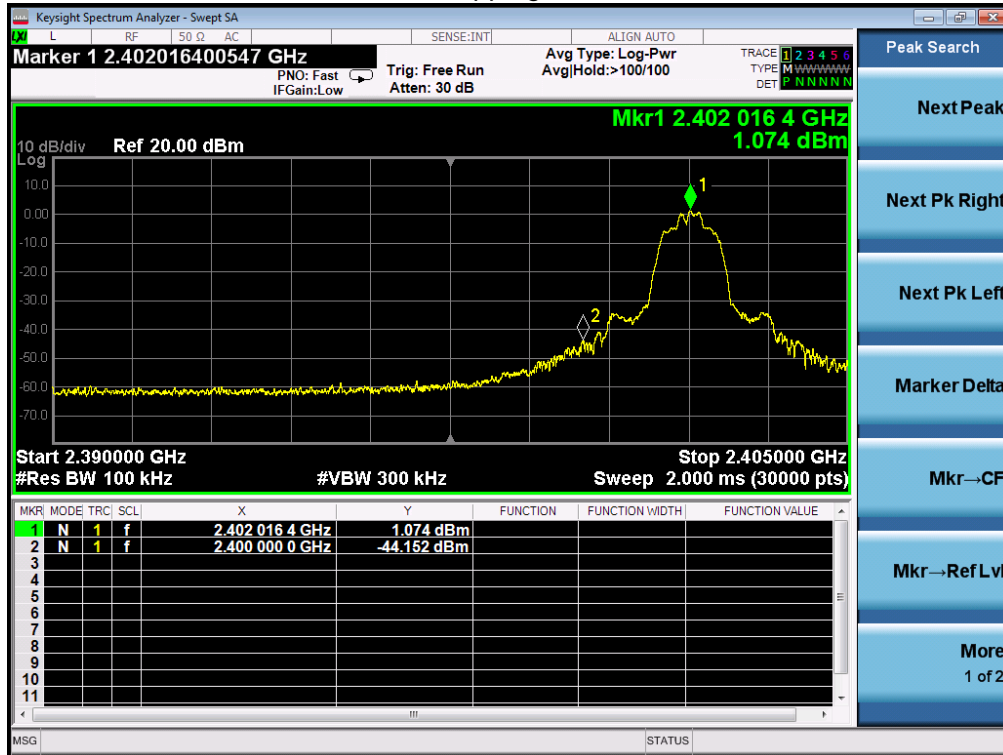

### Hopping on

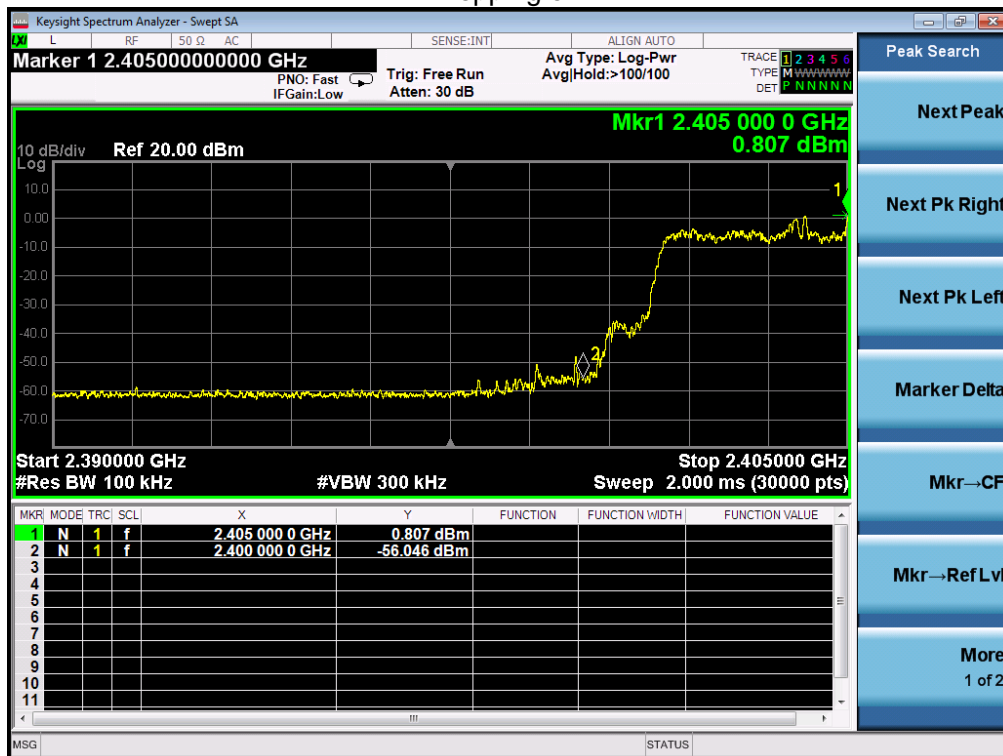



### $\pi$ /4-DQPSK MODULATION IN HIGH CHANNEL Hopping off

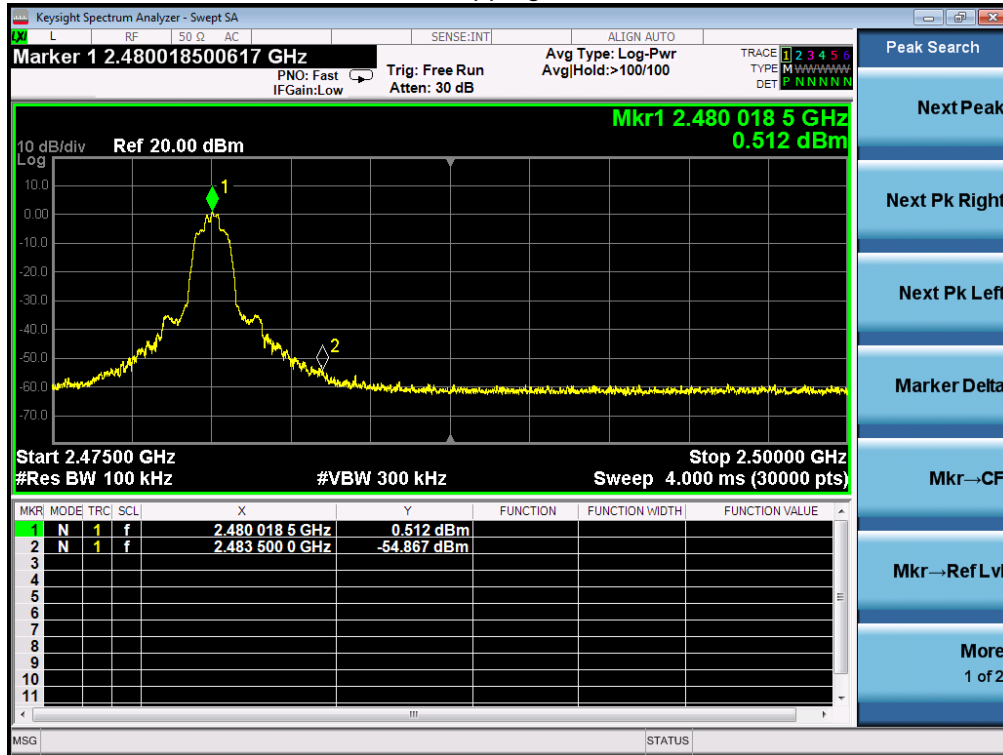

### Hopping on

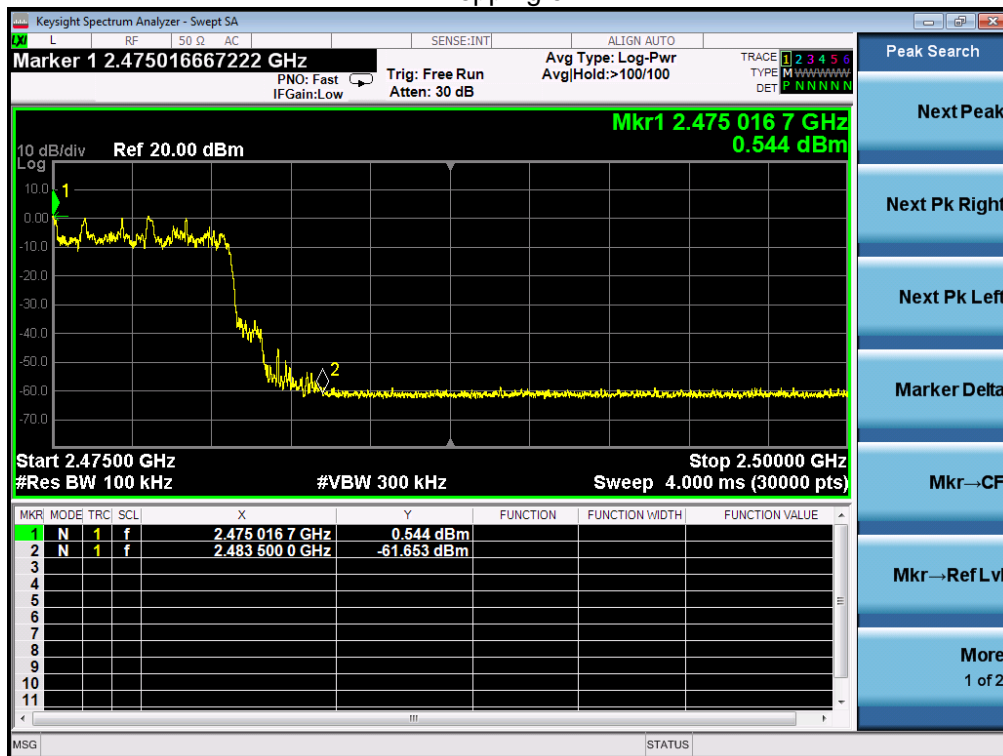









## 6. Radiated Emission

### 6.1. Measurement Procedure

1. The EUT was placed on the top of the turntable 0.8 or 1.5 meter above ground. The phase center of the receiving antenna mounted on the top of a height-variable antenna tower was placed 3 meters far away from the turntable.
2. Power on the EUT and all the supporting units. The turntable was rotated by 360 degrees to determine the position of the highest radiation.
3. The height of the broadband receiving antenna was varied between one meter and four meters above ground to find the maximum emissions field strength of both horizontal and vertical polarization.
4. For each suspected emissions, the antenna tower was scan (from 1 M to 4 M) and then the turntable was rotated (from 0 degree to 360 degrees) to find the maximum reading.
5. Set the test-receiver system to Peak or CISPR quasi-peak Detect Function with specified bandwidth under Maximum Hold Mode.
6. For emissions above 1GHz, use 1MHz RBW and 3MHz VBW for peak reading. Place the measurement antenna away from each area of the EUT determined to be a source of emissions at the specified measurement distance, while keeping the measurement antenna aimed at the source of emissions at each frequency of significant emissions, with polarization oriented for maximum response. The measurement antenna may have to be higher or lower than the EUT, depending on the radiation pattern of the emission and staying aimed at the emission source for receiving the maximum signal. The final measurement antenna elevation shall be that which maximizes the emissions. The measurement antenna elevation for maximum emissions shall be restricted to a range of heights of from 1 m to 4 m above the ground or reference ground plane.
7. When the radiated emissions limits are expressed in terms of the average value of the emissions, and pulsed operation is employed, the measurement field strength shall be determined by averaging over one complete pulse train, including blanking intervals, as long as the pulse train does not exceed 0.1 seconds. As an alternative (provided the transmitter operates for longer than 0.1 seconds) or in cases where the pulse train exceeds 0.1 seconds, the measured field strength shall be determined from the average absolute voltage during a 0.1 second interval during which the field strength is at its maximum values.
8. If the emissions level of the EUT in peak mode was 3 dB lower than the average limit specified, then testing will be stopped and peak values of EUT will be reported, otherwise, the emissions which do not have 3 dB margin will be repeated one by one using the quasi-peak method for below 1GHz.
9. For testing above 1GHz, the emissions level of the EUT in peak mode was lower than average limit (that means the emissions level in peak mode also complies with the limit in average mode), then testing will be stopped and peak values of EUT will be reported, otherwise, the emissions will be measured in average mode again and reported.
10. In case the emission is lower than 30MHz, loop antenna has to be used for measurement and the recorded data should be QP measured by receiver. High - Low scan is not required in this case.



The following table is the setting of spectrum analyzer and receiver.

| <b>Spectrum Parameter</b> | <b>Setting</b>  |
|---------------------------|---|
| Start ~Stop Frequency     | 9KHz~150KHz/RB 200Hz for QP                               |
| Start ~Stop Frequency     | 150KHz~30MHz/RB 9KHz for QP                               |
| Start ~Stop Frequency     | 30MHz~1000MHz/RB 120KHz for QP                            |
| Start ~Stop Frequency     | 1GHz~26.5GHz<br>1MHz/3MHz for Peak, 1MHz/10Hz for Average |

| <b>Receiver Parameter</b> | <b>Setting</b>                 |
|---------------------------|--------------------------------|
| Start ~Stop Frequency     | 9KHz~150KHz/RB 200Hz for QP    |
| Start ~Stop Frequency     | 150KHz~30MHz/RB 9KHz for QP    |
| Start ~Stop Frequency     | 30MHz~1000MHz/RB 120KHz for QP |

## 6.2. Test Setup

Radiated Emission Test-Setup Frequency Below 30MHz

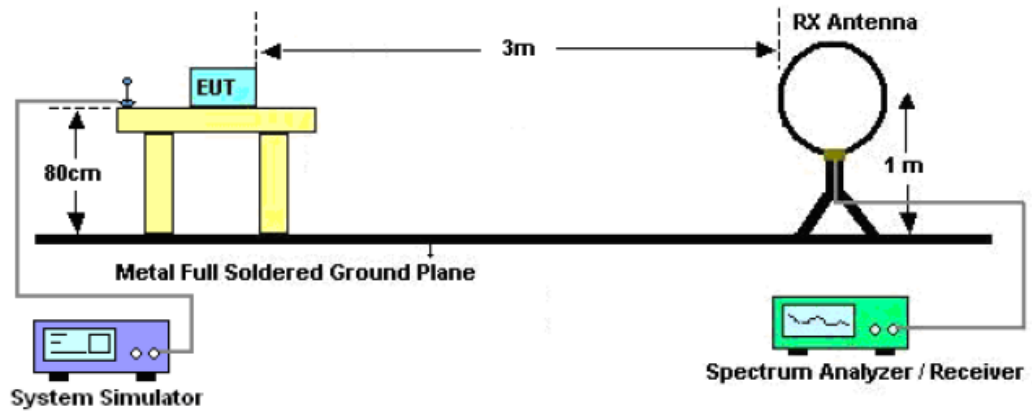

RADIATED EMISSION TEST SETUP 30MHz-1000MHz

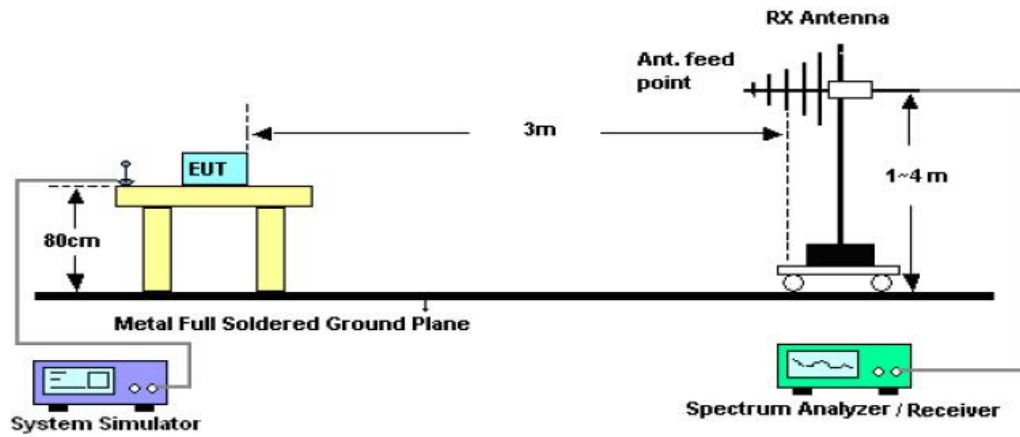

RADIATED EMISSION TEST SETUP ABOVE 1000MHz

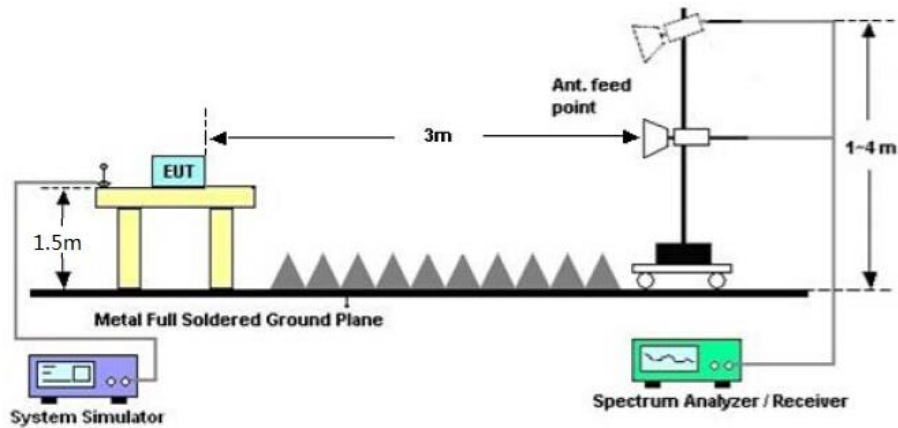



### 6.3. Limits and Measurement Result

15.209&RSS-GEN Limit in the below table has to be followed

| <b>Frequencies<br/>(MHz)</b> | <b>Field Strength<br/>(micровolts/meter)</b> | <b>Measurement Distance<br/>(meters)</b> |
|------------------------------|--|--|
| 0.009~0.490                  | 2400/F(KHz)                                  | 300                                      |
| 0.490~1.705                  | 24000/F(KHz)                                 | 30                                       |
| 1.705~30.0                   | 30   | 30                                       |
| 30~88                        | 100  | 3  |
| 88~216                       | 150  | 3  |
| 216~960                      | 200  | 3  |
| Above 960                    | 500  | 3  |

Note: All modes were tested For restricted band radiated emission,  
the test records reported below are the worst result compared to other modes.



**RADIATED EMISSION BELOW 30MHZ**

No emission found between lowest internal used/generated frequencies to 30MHz.

**RADIATED EMISSION BELOW 1GHZ**

|                    |                     |                          |                |
|--------------------|---------------------|--------------------------|----------------|
| <b>EUT</b>         | Wireless Headphones | <b>Model Name</b>        | M10            |
| <b>Temperature</b> | 25°C                | <b>Relative Humidity</b> | 55.4%          |
| <b>Pressure</b>    | 960hPa              | <b>Test Voltage</b>      | Normal Voltage |
| <b>Test Mode</b>   | Mode 4              | <b>Antenna</b>           | Horizontal     |

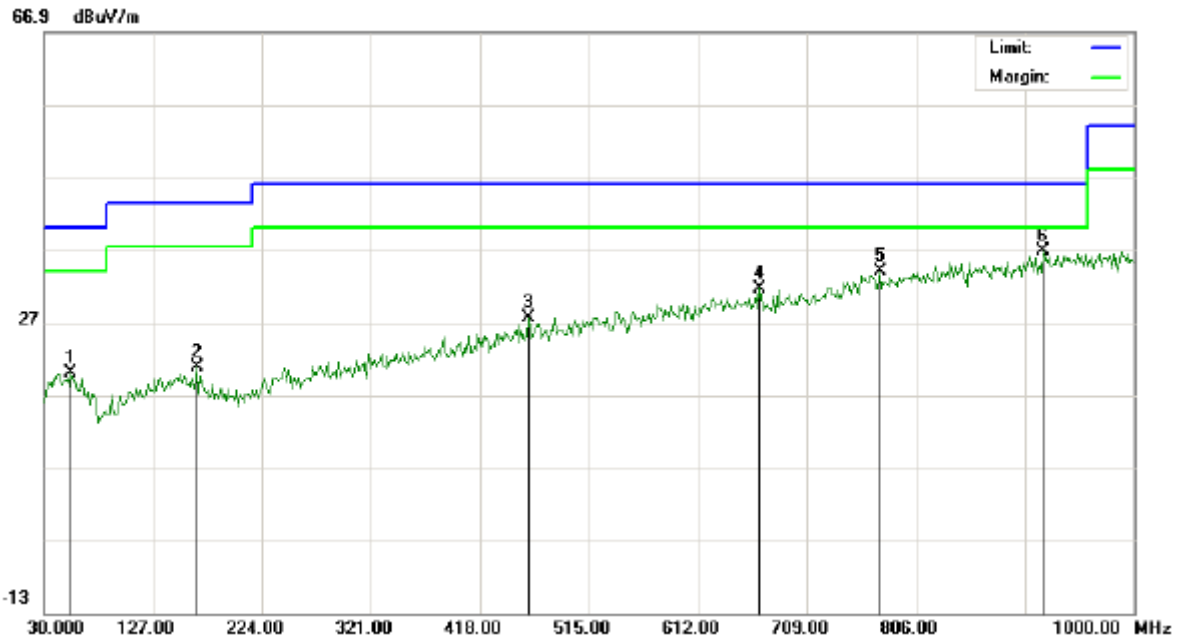

| No. | Mk | Freq.    | Reading | Factor | Measurement | Limit  | Over   | Detector | Antenna Height | Table Degree | Comment |
|-----|----|----------|---------|--------|-------------|--------|--------|----------|----------------|--------------|---------|
|     |    | MHz      | dBuV    | dB/m   | dBuV/m      | dBuV/m | dB     |          | cm             | degree       |         |
| 1   |    | 54.2500  | -0.08   | 20.01  | 19.93       | 40.00  | -20.07 | peak     |                |              |         |
| 2   |    | 165.8000 | 1.04    | 19.77  | 20.81       | 43.50  | -22.69 | peak     |                |              |         |
| 3   |    | 461.6500 | 1.40    | 26.26  | 27.66       | 46.00  | -18.34 | peak     |                |              |         |
| 4   |    | 666.9667 | 1.46    | 30.24  | 31.70       | 46.00  | -14.30 | peak     |                |              |         |
| 5   |    | 773.6667 | 1.56    | 32.53  | 34.09       | 46.00  | -11.91 | peak     |                |              |         |
| 6   | *  | 919.1667 | 2.00    | 34.86  | 36.86       | 46.00  | -9.14  | peak     |                |              |         |

**RESULT: PASS**



|                    |                     |                          |                |
|--------------------|---------------------|--------------------------|----------------|
| <b>EUT</b>         | Wireless Headphones | <b>Model Name</b>        | M10            |
| <b>Temperature</b> | 25°C                | <b>Relative Humidity</b> | 55.4%          |
| <b>Pressure</b>    | 960hPa              | <b>Test Voltage</b>      | Normal Voltage |
| <b>Test Mode</b>   | Mode 4              | <b>Antenna</b>           | Vertical       |

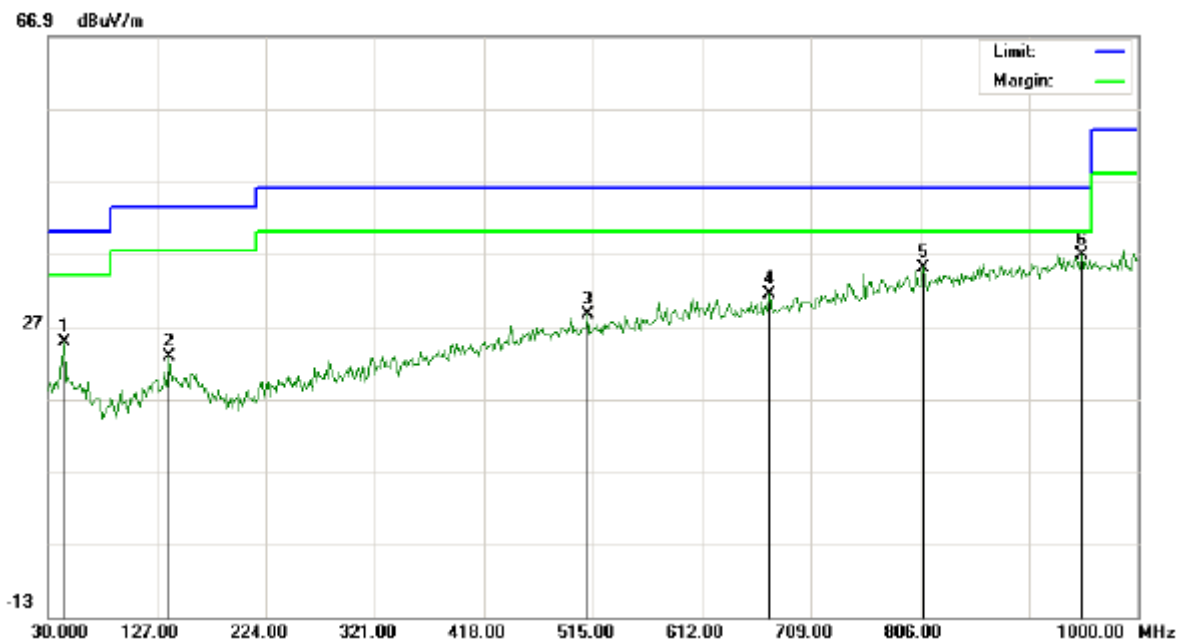

| No. | Mk | Freq.    | Reading | Factor | Measurement | Limit  | Over   | Detector | Antenna Height | Table Degree | Comment |
|-----|----|----------|---------|--------|-------------|--------|--------|----------|----------------|--------------|---------|
|     |    | MHz      | dBuV    | dB/m   | dBuV/m      | dBuV/m | dB     |          | cm             | degree       |         |
| 1   |    | 44.5500  | 4.36    | 20.51  | 24.87       | 40.00  | -15.13 | peak     |                |              |         |
| 2   |    | 138.3167 | 2.55    | 20.17  | 22.72       | 43.50  | -20.78 | peak     |                |              |         |
| 3   |    | 510.1500 | 1.24    | 27.35  | 28.59       | 46.00  | -17.41 | peak     |                |              |         |
| 4   |    | 671.8167 | 1.15    | 30.32  | 31.47       | 46.00  | -14.53 | peak     |                |              |         |
| 5   |    | 809.2333 | 1.79    | 33.31  | 35.10       | 46.00  | -10.90 | peak     |                |              |         |
| 6   | *  | 949.8833 | 1.57    | 35.17  | 36.74       | 46.00  | -9.26  | peak     |                |              |         |

**RESULT: PASS**

**Note:** 1. Factor=Antenna Factor + Cable loss, Margin=Measurement-Limit.

2. All test modes had been pre-tested. The mode 4 is the worst case and recorded in the report.

**RADIATED EMISSION ABOVE 1GHZ**

|                    |                     |                          |                |
|--------------------|---------------------|--------------------------|----------------|
| <b>EUT</b>         | Wireless Headphones | <b>Model Name</b>        | M10            |
| <b>Temperature</b> | 25°C                | <b>Relative Humidity</b> | 55.4%          |
| <b>Pressure</b>    | 960hPa              | <b>Test Voltage</b>      | Normal Voltage |
| <b>Test Mode</b>   | Mode 1              | <b>Antenna</b>           | Horizontal     |

| Frequency | Meter Reading | Factor | Emission Level | Limits         | Margin | Value Type |
|-----------|---------------|--------|----------------|----------------|--------|------------|
| (MHz)     | (dB $\mu$ V)  | (dB)   | (dB $\mu$ V/m) | (dB $\mu$ V/m) | (dB)   |            |
| 4804.062  | 46.69         | 3.76   | 50.45          | 74.00          | -23.55 | peak       |
| 4804.062  | 43.39         | 3.76   | 47.15          | 54.00          | -6.85  | AVG        |
| 7206.093  | 34.61         | 8.17   | 42.78          | 74.00          | -31.22 | peak       |
| 7206.093  | 32.71         | 8.17   | 40.88          | 54.00          | -13.12 | AVG        |

Remark:

Factor = Antenna Factor + Cable Loss – Pre-amplifier.

|                    |                     |                          |                |
|--------------------|---------------------|--------------------------|----------------|
| <b>EUT</b>         | Wireless Headphones | <b>Model Name</b>        | M10            |
| <b>Temperature</b> | 25°C                | <b>Relative Humidity</b> | 55.4%          |
| <b>Pressure</b>    | 960hPa              | <b>Test Voltage</b>      | Normal Voltage |
| <b>Test Mode</b>   | Mode 1              | <b>Antenna</b>           | Vertical       |

| Frequency | Meter Reading | Factor | Emission Level | Limits         | Margin | Value Type |
|-----------|---------------|--------|----------------|----------------|--------|------------|
| (MHz)     | (dB $\mu$ V)  | (dB)   | (dB $\mu$ V/m) | (dB $\mu$ V/m) | (dB)   |            |
| 4804.062  | 48.39         | 3.76   | 52.15          | 74.00          | -21.86 | peak       |
| 4804.062  | 43.45         | 3.76   | 47.21          | 54.00          | -6.79  | AVG        |
| 7206.093  | 38.64         | 8.17   | 46.81          | 74.00          | -27.19 | peak       |
| 7206.093  | 35.88         | 8.17   | 44.05          | 54.00          | -9.95  | AVG        |

Remark:

Factor = Antenna Factor + Cable Loss – Pre-amplifier.





|                    |                     |                          |                |
|--------------------|---------------------|--------------------------|----------------|
| <b>EUT</b>         | Wireless Headphones | <b>Model Name</b>        | M10            |
| <b>Temperature</b> | 25°C                | <b>Relative Humidity</b> | 55.4%          |
| <b>Pressure</b>    | 960hPa              | <b>Test Voltage</b>      | Normal Voltage |
| <b>Test Mode</b>   | Mode 2              | <b>Antenna</b>           | Horizontal     |

| Frequency | Meter Reading | Factor | Emission Level | Limits         | Margin | Value Type |
|-----------|---------------|--------|----------------|----------------|--------|------------|
| (MHz)     | (dB $\mu$ V)  | (dB)   | (dB $\mu$ V/m) | (dB $\mu$ V/m) | (dB)   |            |
| 4882.062  | 52.00         | 3.78   | 55.78          | 74.00          | -18.22 | peak       |
| 4882.062  | 43.76         | 3.78   | 47.54          | 54.00          | -6.46  | AVG        |
| 7323.093  | 42.48         | 8.23   | 50.71          | 74.00          | -23.29 | peak       |
| 7323.093  | 37.82         | 8.23   | 46.05          | 54.00          | -7.95  | AVG        |

Remark:

Factor = Antenna Factor + Cable Loss – Pre-amplifier.

|                    |                     |                          |                |
|--------------------|---------------------|--------------------------|----------------|
| <b>EUT</b>         | Wireless Headphones | <b>Model Name</b>        | M10            |
| <b>Temperature</b> | 25°C                | <b>Relative Humidity</b> | 55.4%          |
| <b>Pressure</b>    | 960hPa              | <b>Test Voltage</b>      | Normal Voltage |
| <b>Test Mode</b>   | Mode 2              | <b>Antenna</b>           | Vertical       |

| Frequency | Meter Reading | Factor | Emission Level | Limits         | Margin | Value Type |
|-----------|---------------|--------|----------------|----------------|--------|------------|
| (MHz)     | (dB $\mu$ V)  | (dB)   | (dB $\mu$ V/m) | (dB $\mu$ V/m) | (dB)   |            |
| 4882.062  | 48.03         | 3.78   | 51.81          | 74.00          | -22.19 | peak       |
| 4882.062  | 45.00         | 3.78   | 48.78          | 54.00          | -5.22  | AVG        |
| 7323.093  | 39.92         | 8.23   | 48.15          | 74.00          | -25.85 | peak       |
| 7323.093  | 38.15         | 8.23   | 46.38          | 54.00          | -7.62  | AVG        |

Remark:

Factor = Antenna Factor + Cable Loss – Pre-amplifier.



|                    |                     |                          |                |
|--------------------|---------------------|--------------------------|----------------|
| <b>EUT</b>         | Wireless Headphones | <b>Model Name</b>        | M10            |
| <b>Temperature</b> | 25°C                | <b>Relative Humidity</b> | 55.4%          |
| <b>Pressure</b>    | 960hPa              | <b>Test Voltage</b>      | Normal Voltage |
| <b>Test Mode</b>   | Mode 3              | <b>Antenna</b>           | Horizontal     |

| Frequency   | Meter Reading | Factor | Emission Level | Limits   | Margin | Value Type |
|---|---------------|--------|----------------|----------|--------|------------|
| (MHz)   | (dBμV)        | (dB)   | (dBμV/m)       | (dBμV/m) | (dB)   |            |
| 4960.062  | 49.23         | 3.81   | 53.04          | 74.00    | -20.96 | peak       |
| 4960.062  | 44.94         | 3.81   | 48.75          | 54.00    | -5.25  | AVG        |
| 7440.093  | 39.88         | 8.27   | 48.15          | 74.00    | -25.86 | peak       |
| 7440.093  | 36.51         | 8.27   | 44.78          | 54.00    | -9.22  | AVG        |
| Remark:   |               |        |                |          |        |            |
| Factor = Antenna Factor + Cable Loss – Pre-amplifier. |               |        |                |          |        |            |

|                    |                     |                          |                |
|--------------------|---------------------|--------------------------|----------------|
| <b>EUT</b>         | Wireless Headphones | <b>Model Name</b>        | M10            |
| <b>Temperature</b> | 25°C                | <b>Relative Humidity</b> | 55.4%          |
| <b>Pressure</b>    | 960hPa              | <b>Test Voltage</b>      | Normal Voltage |
| <b>Test Mode</b>   | Mode 3              | <b>Antenna</b>           | Vertical       |

| Frequency   | Meter Reading | Factor | Emission Level | Limits   | Margin | Value Type |
|---|---------------|--------|----------------|----------|--------|------------|
| (MHz)   | (dBμV)        | (dB)   | (dBμV/m)       | (dBμV/m) | (dB)   |            |
| 4960.062  | 47.90         | 3.81   | 51.71          | 74.00    | -22.29 | peak       |
| 4960.062  | 44.65         | 3.81   | 48.46          | 54.00    | -5.54  | AVG        |
| 7440.093  | 40.34         | 8.27   | 48.61          | 74.00    | -25.39 | peak       |
| 7440.093  | 36.95         | 8.27   | 45.22          | 54.00    | -8.78  | AVG        |
| Remark:   |               |        |                |          |        |            |
| Factor = Antenna Factor + Cable Loss – Pre-amplifier. |               |        |                |          |        |            |

**RESULT: PASS**

**Note:**

Other emissions from 1G to 25 GHz are considered as ambient noise. No recording in the test report.

Factor = Antenna Factor + Cable loss - Amplifier gain, Over=Measure-Limit.

The "Factor" value can be calculated automatically by software of measurement system.

All test modes had been tested. The GFSK modulation is the worst case and recorded in the report.



**TEST RESULT FOR RESTRICTED BANDS REQUIREMENTS**

|                    |                     |                          |                |
|--------------------|---------------------|--------------------------|----------------|
| <b>EUT</b>         | Wireless Headphones | <b>Model Name</b>        | M10            |
| <b>Temperature</b> | 25°C                | <b>Relative Humidity</b> | 55.4%          |
| <b>Pressure</b>    | 960hPa              | <b>Test Voltage</b>      | Normal Voltage |
| <b>Test Mode</b>   | Mode 1              | <b>Antenna</b>           | Horizontal     |

PK

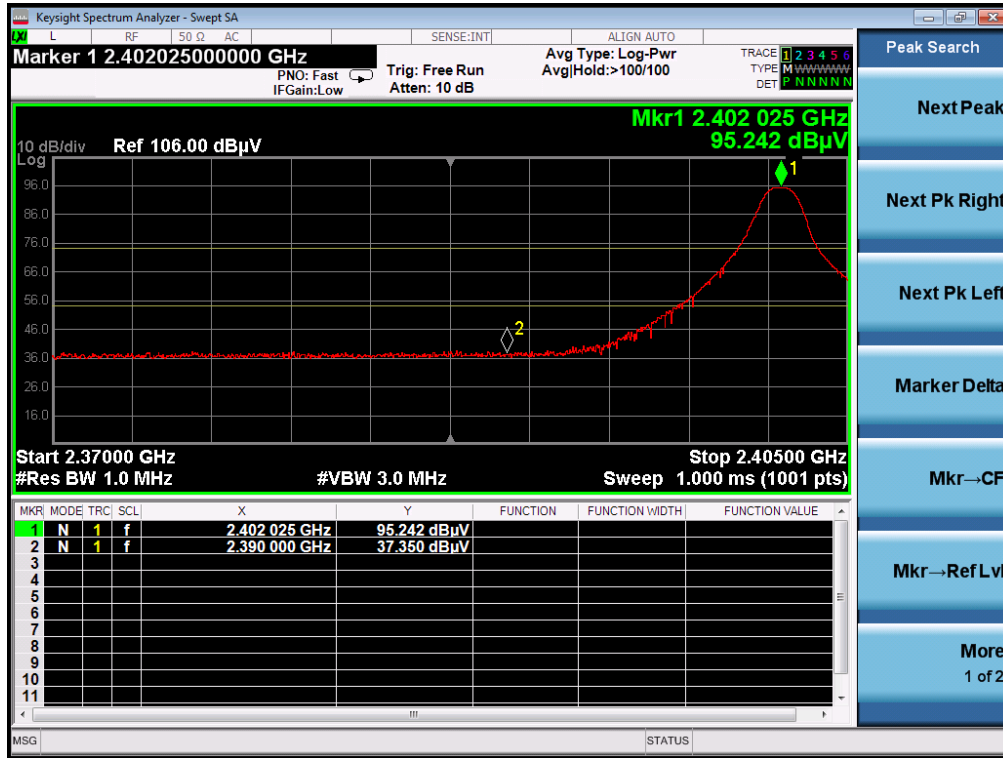

AV

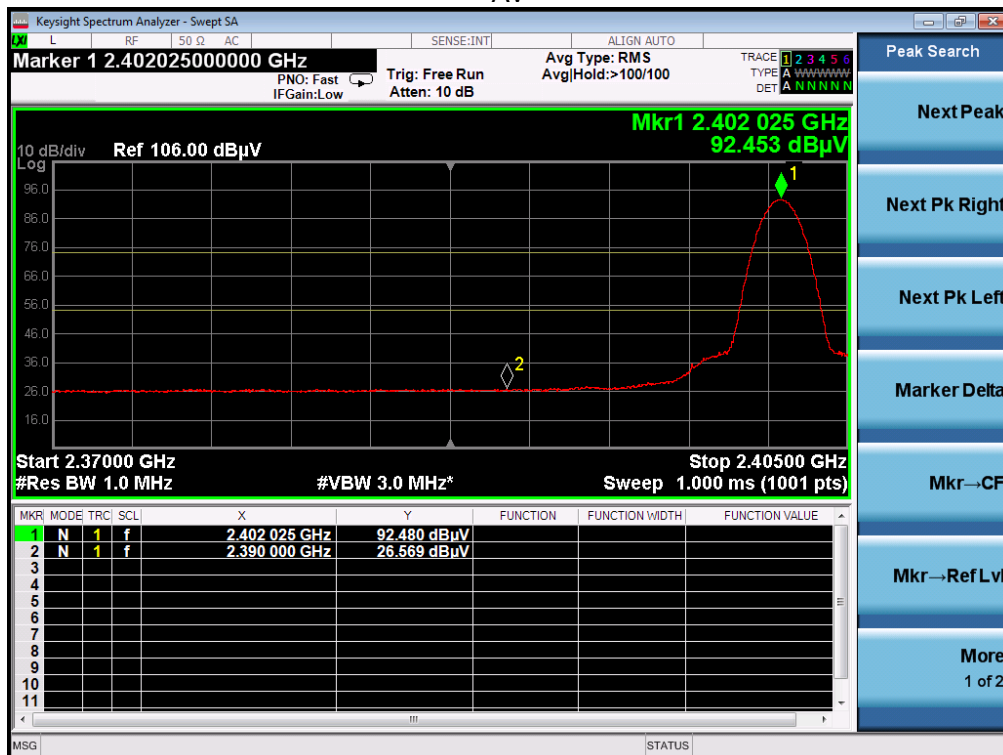

**RESULT: PASS**



|             |                     |                   |                |
|-------------|---------------------|-------------------|----------------|
| EUT         | Wireless Headphones | Model Name        | M10            |
| Temperature | 25°C                | Relative Humidity | 55.4%          |
| Pressure    | 960hPa              | Test Voltage      | Normal Voltage |
| Test Mode   | Mode 1              | Antenna           | Vertical       |

PK

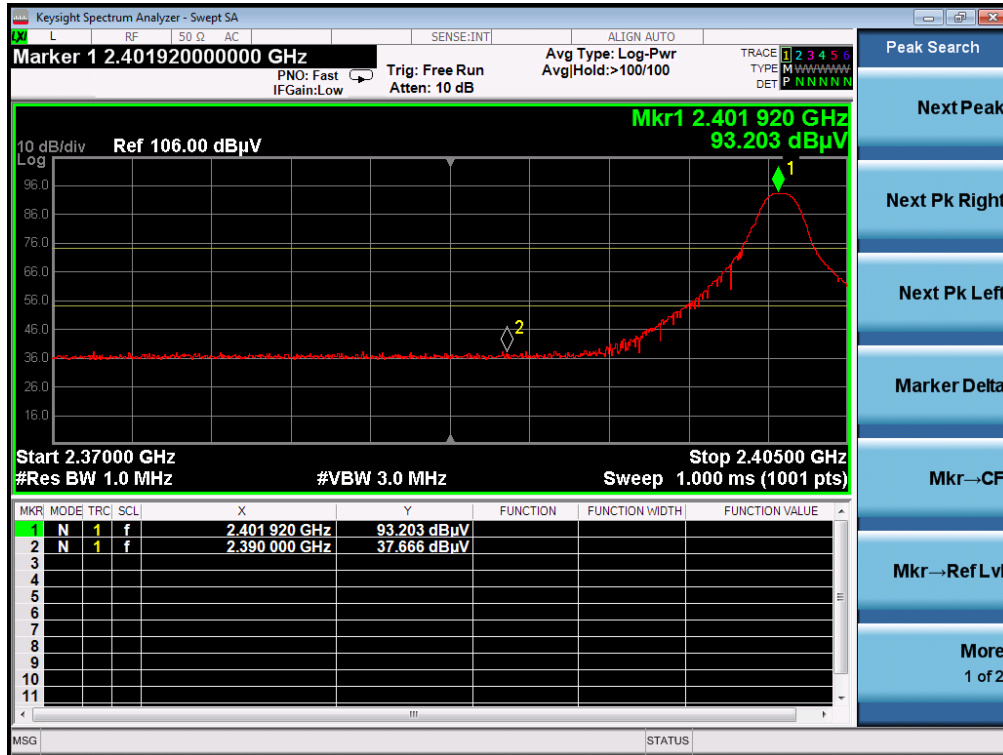

AV

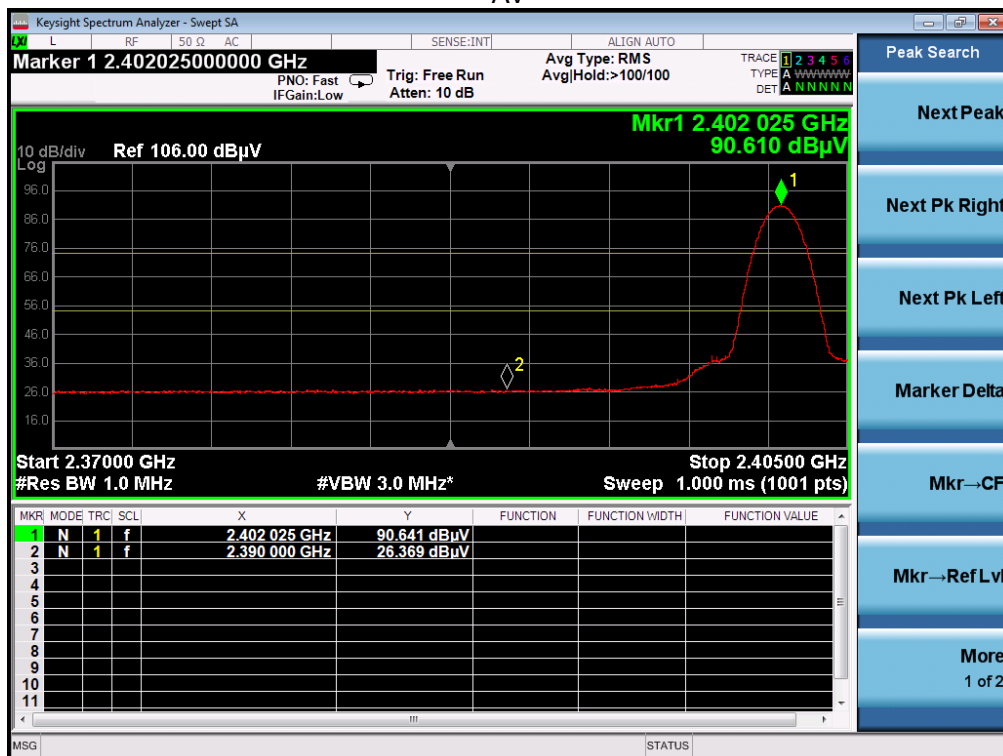

RESULT: PASS



|             |                     |                   |                |
|-------------|---------------------|-------------------|----------------|
| EUT         | Wireless Headphones | Model Name        | M10            |
| Temperature | 25°C                | Relative Humidity | 55.4%          |
| Pressure    | 960hPa              | Test Voltage      | Normal Voltage |
| Test Mode   | Mode 3              | Antenna           | Horizontal     |

PK

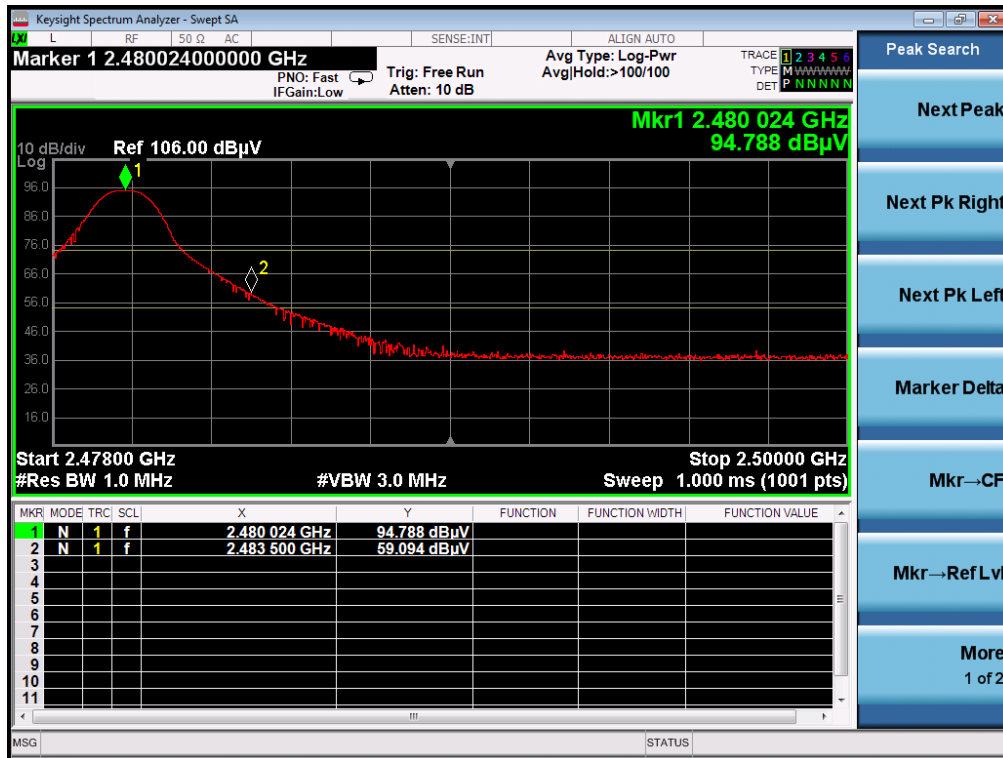

AV



RESULT: PASS



|             |                     |                   |                |
|-------------|---------------------|-------------------|----------------|
| EUT         | Wireless Headphones | Model Name        | M10            |
| Temperature | 25°C                | Relative Humidity | 55.4%          |
| Pressure    | 960hPa              | Test Voltage      | Normal Voltage |
| Test Mode   | Mode 3              | Antenna           | Vertical       |

PK

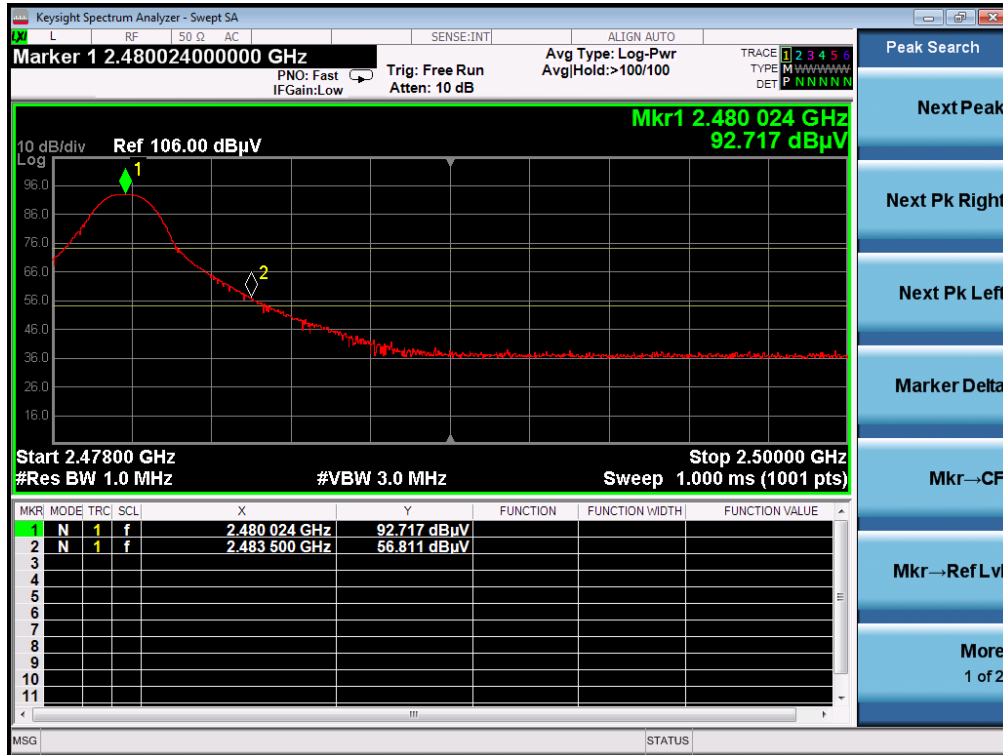

AV

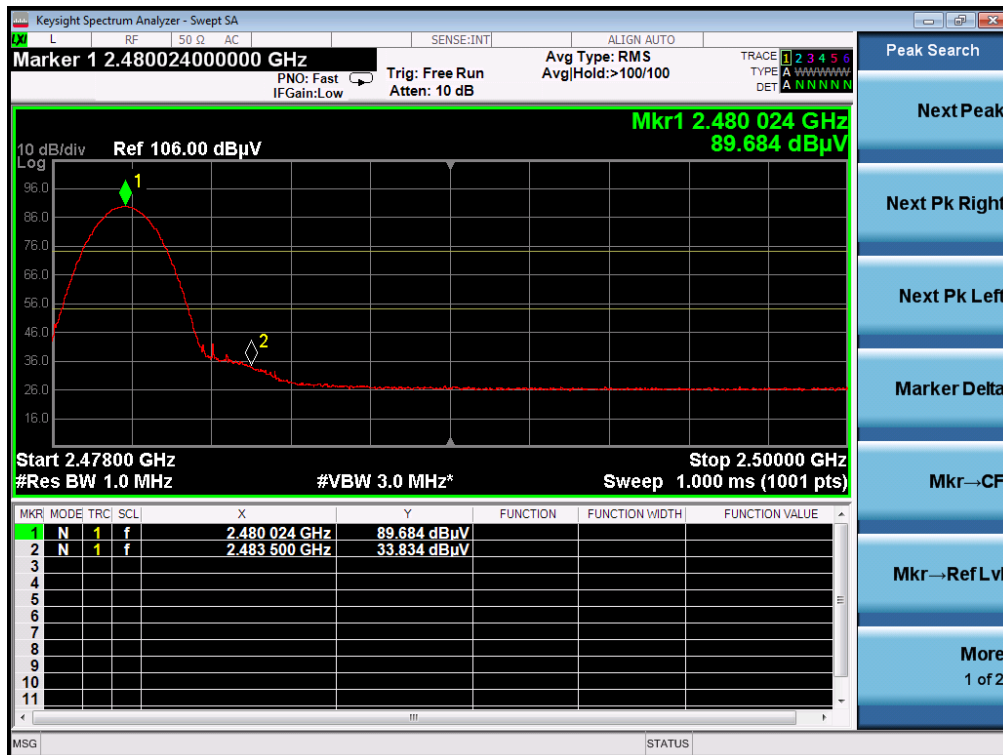

**RESULT: PASS**

**Note:** The factor had been edited in the "Input Correction" of the Spectrum Analyzer. So the Amplitude of test plots is equal to Reading level plus the Factor in dB. Use the A dB(µV) to represent the Amplitude. Use the F dB(µV/m) to represent the Field Strength. So A=F. All test modes had been pre-tested. The GFSK modulation is the worst case and recorded in the report.



## 7. Number of Hopping Frequency

### 7.1. Measurement Procedure

The EUT shall have its hopping function enabled. Use the following spectrum analyzer settings:

1. Span: The frequency band of operation. Depending on the number of channels the device supports, it may be necessary to divide the frequency range of operation across multiple spans, to allow the individual channels to be clearly seen.
2. RBW: To identify clearly the individual channels, set the RBW to less than 30% of the channel spacing or the 20 dB bandwidth, whichever is smaller.
3. VBW  $\geq$  RBW. Sweep: Auto. Detector function: Peak. Trace: Max hold.
4. Allow the trace to stabilize.

### 7.2. Test Setup (Block Diagram of Configuration)

Same as described in section 4.2

### 7.3. Limits and Measurement Result

| TOTAL NO. OF HOPPING CHANNEL | LIMIT (NO. OF CH) | MEASUREMENT (NO. OF CH) | RESULT |
|------------------------------|-------------------|-------------------------|--------|
|                              | $\geq 15$         | 79                      | PASS   |

TEST PLOT FOR NO. OF TOTAL CHANNELS

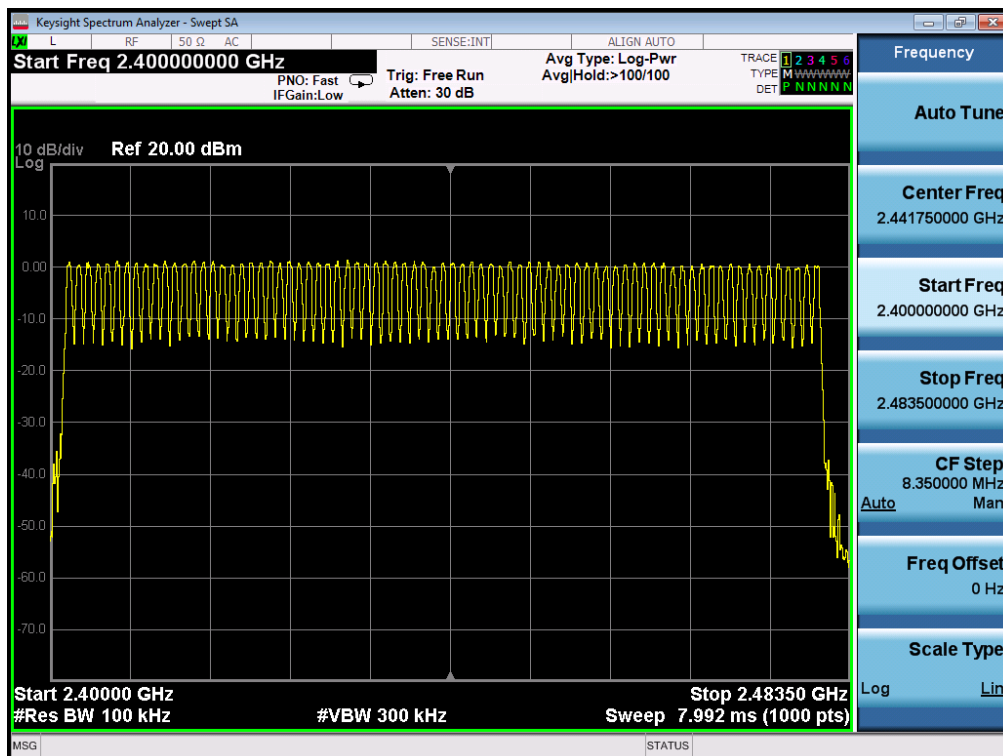

Note: The 8-DPSK modulation is the worst case and recorded in the report.



## 8. Time Of Occupancy (Dwell Time)

### 8.1. Measurement Procedure

The EUT shall have its hopping function enabled. Use the following spectrum analyzer settings:

1. Span: Zero span, centered on a hopping channel.
2. RBW shall be  $\leq$  channel spacing and where possible RBW should be set  $\gg 1 / T$ , where T is the expected dwell time per channel.
3. Sweep: As necessary to capture the entire dwell time per hopping channel; where possible use a video trigger and trigger delay so that the transmitted signal starts a little to the right of the start of the plot. The trigger level might need slight adjustment to prevent triggering when the system hops on an adjacent channel; a second plot might be needed with a longer sweep time to show two successive hops on a channel.
4. Detector function: Peak. Trace: Max hold.
5. Use the marker-delta function to determine the transmit time per hop.
6. Repeat the measurement using a longer sweep time to determine the number of hops over the period specified in the requirements. The sweep time shall be equal to, or less than, the period specified in the requirements. Determine the number of hops over the sweep time and calculate the total number of hops in the period specified in the requirements, using the following equation:  
 (Number of hops in the period specified in the requirements) = (number of hops on spectrum analyzer)  $\times$  (period specified in the requirements / analyzer sweep time)
7. The average time of occupancy is calculated from the transmit time per hop multiplied by the number of hops in the period specified in the requirements.

### 8.2. Test Setup (Block Diagram of Configuration)

Same as described in section 4.2

### 8.3. Limits and Measurement Result

| Channel | Time of Pulse for DH5 (ms) | Number of hops in the period specified in the requirements | Sweep Time (ms) | Limit (ms) |
|---------|----------------------------|--|-----------------|------------|
| Low     | 2.860                      | 24*4   | 274.560         | 400        |
| Middle  | 2.896                      | 22*4   | 254.848         | 400        |
| High    | 2.891                      | 22*4   | 254.408         | 400        |

Note: The 8-DPSK modulation is the worst case and recorded in the report.





### TEST PLOT OF LOW CHANNEL

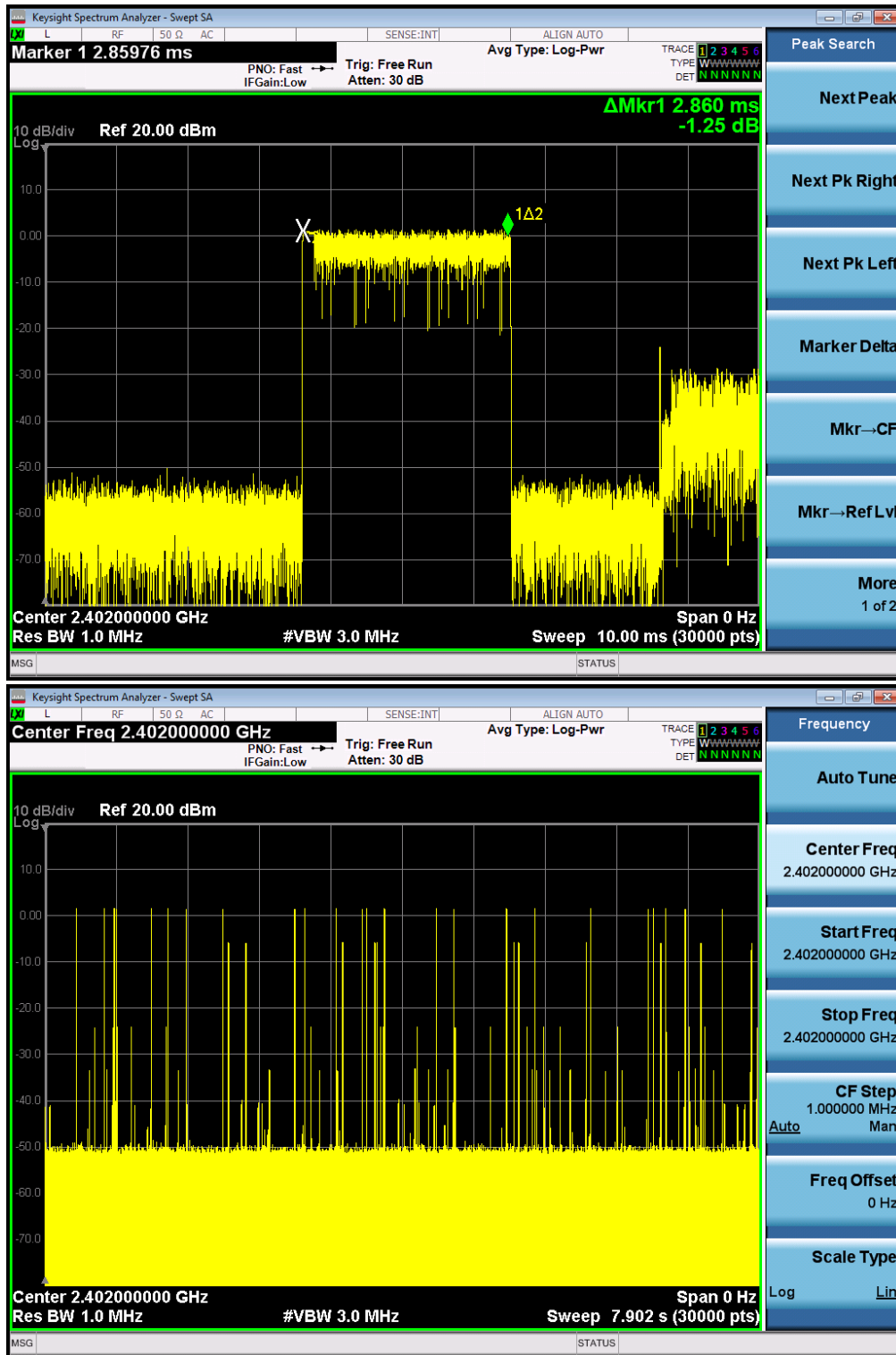



### TEST PLOT OF MIDDLE CHANNEL

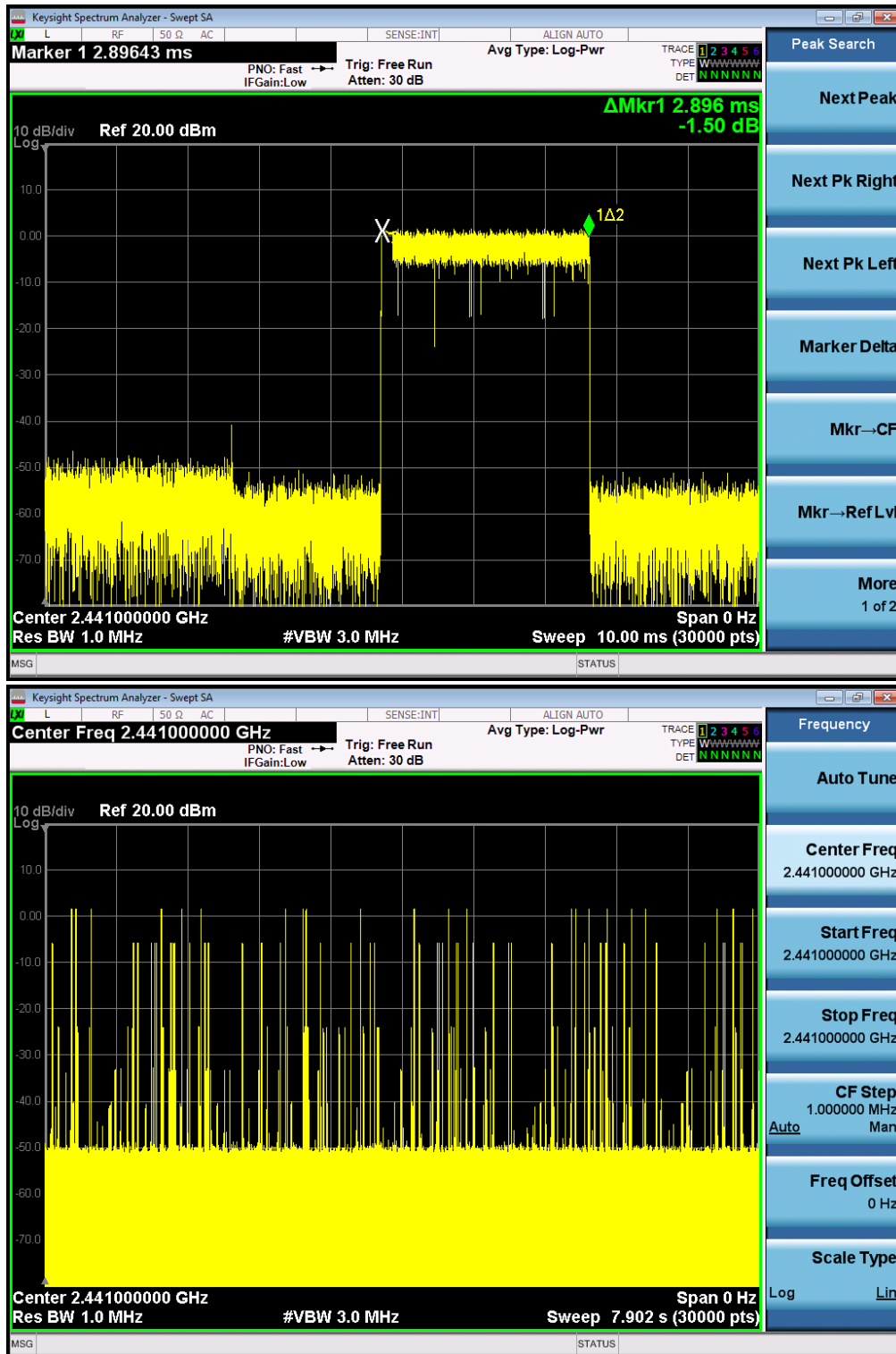



### TEST PLOT OF HIGH CHANNEL

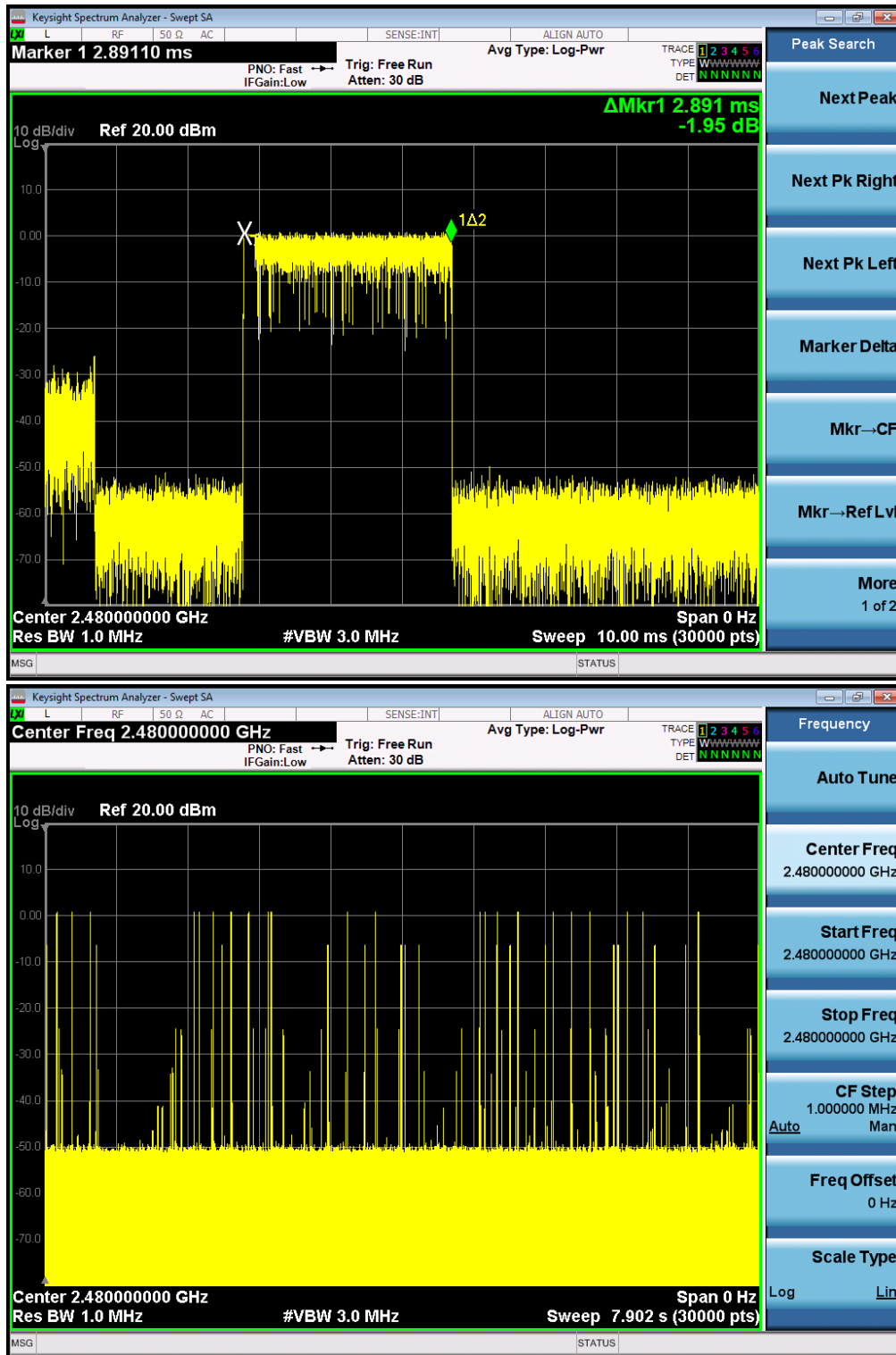



## 9. Frequency Separation

### 9.1. Measurement Procedure

The EUT shall have its hopping function enabled. Use the following spectrum analyzer settings:

1. Span: Wide enough to capture the peaks of two adjacent channels.
  2. RBW: Start with the RBW set to approximately 30% of the channel spacing; adjust as necessary to best identify the center of each individual channel.
  3. Video (or average) bandwidth (VBW)  $\geq$  RBW.
  4. Sweep: Auto. e) Detector function: Peak. f) Trace: Max hold. g) Allow the trace to stabilize.
- Use the marker-delta function to determine the separation between the peaks of the adjacent channels.

### 9.2. Test Setup (Block Diagram of Configuration)

Same as described in section 4.2

### 9.3. Limits and Measurement Result

| CHANNEL   | CHANNEL SEPARATION | LIMIT                         | RESULT |
|-----------|--------------------|-------------------------------|--------|
|           | KHz                | KHz                           |        |
| CH01-CH02 | 1000               | $\geq 25$ KHz or 2/3 20 dB BW | Pass   |

TEST PLOT FOR FREQUENCY SEPARATION



Note: The 8-DPSK modulation is the worst case and recorded in the report.

## 10. Test Setup Photos of the EUT

Radiated Emission





# 11. Photograph of EUT

ALL VIEW OF EUT







TOP VIEW OF EUT



BOTTOM VIEW OF EUT



FRONT VIEW OF EUT



BACK VIEW OF EUT





LEFT VIEW OF EUT



RIGHT VIEW OF EUT





OPEN VIEW OF EUT-1



OPEN VIEW OF EUT-2

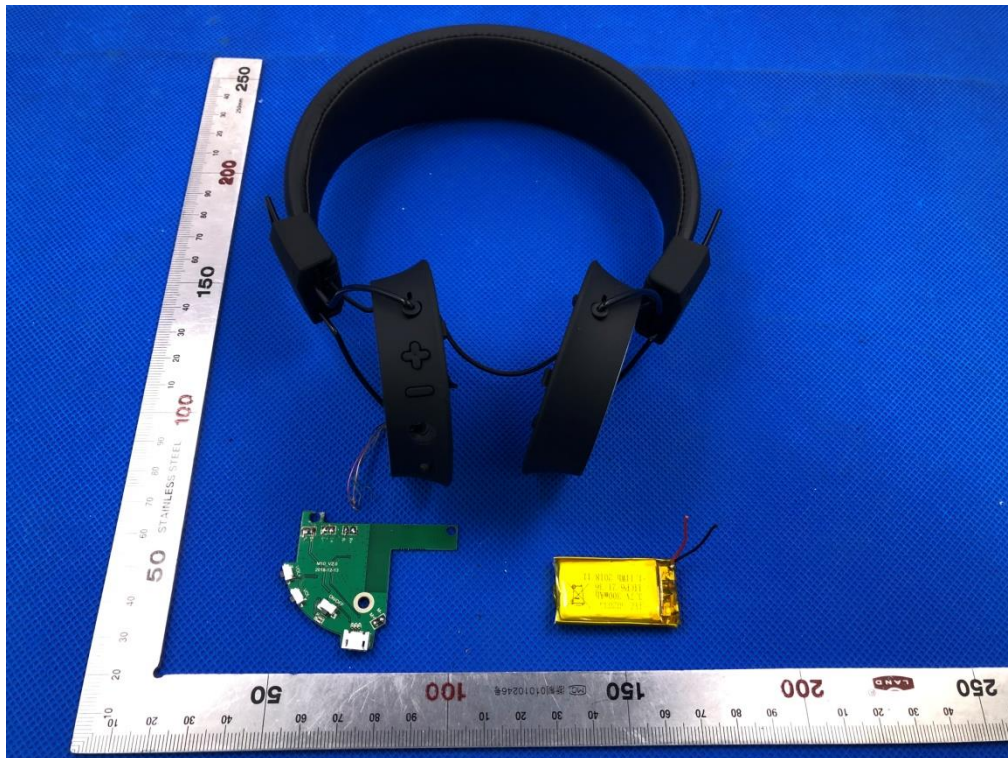



VIEW OF BATTERY

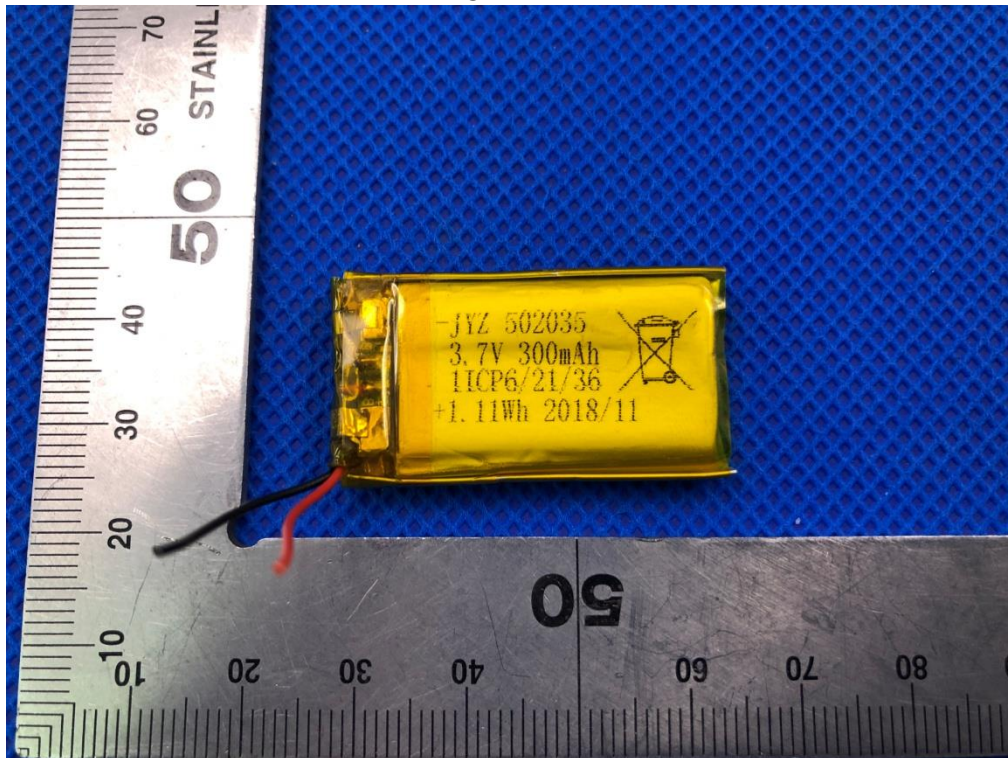

INTERNAL VIEW OF EUT-1

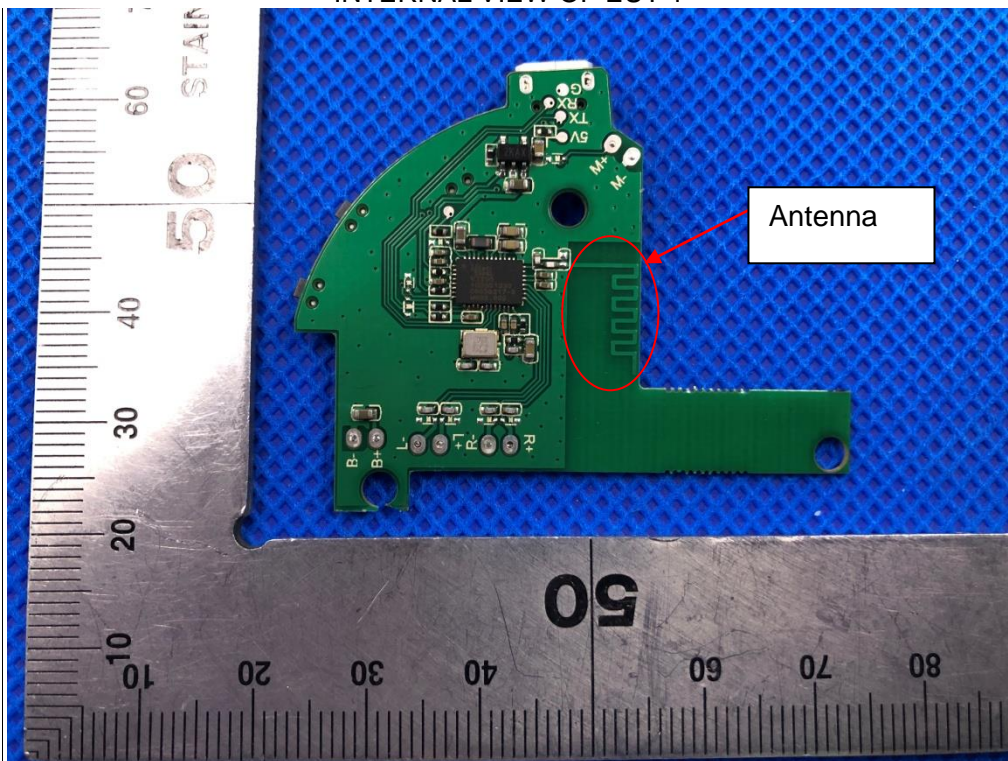



INTERNAL VIEW OF EUT-2

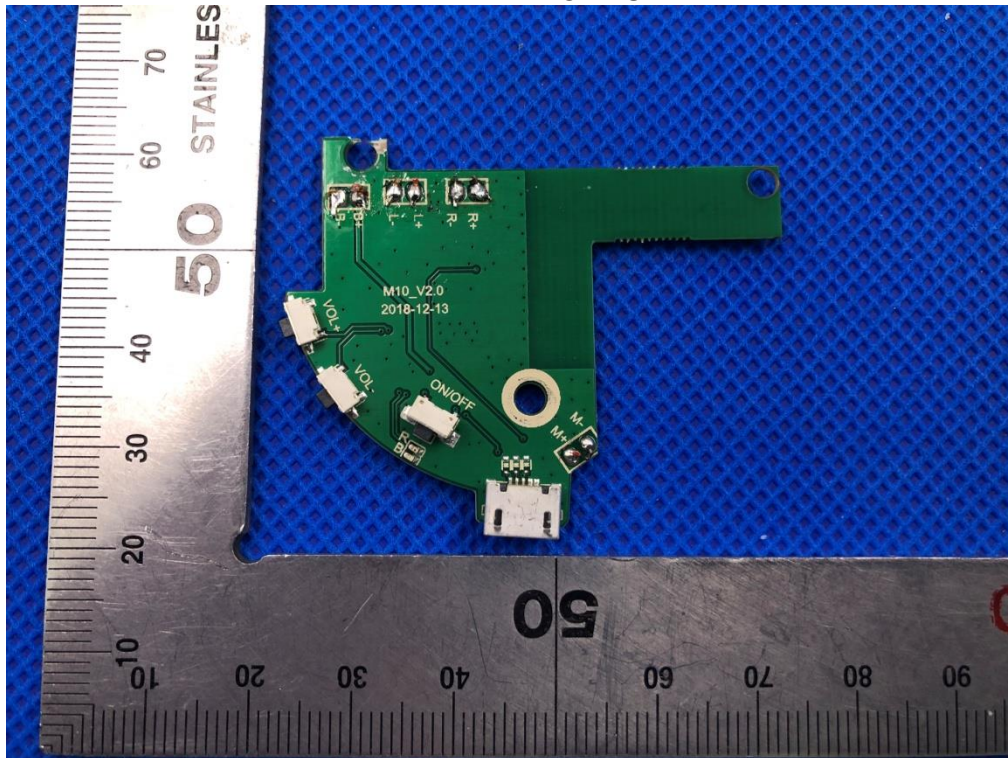

INTERNAL VIEW OF EUT-3

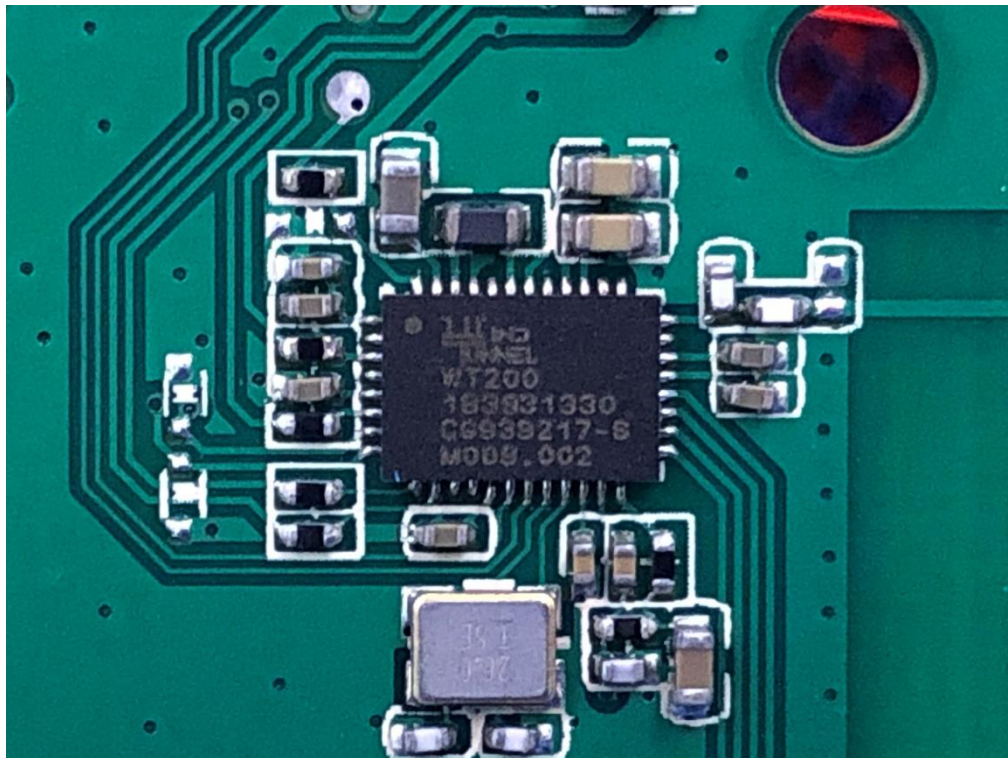

---END OF REPORT---