

TEST REPORT

OF

FCC Part 15 Subpart C §15.209

FCC ID: 2AD5K-PTC100

Equipment Under Test : Wireless Charging Pad
Model Name : PTC-100
Applicant : PARTRON Co., Ltd.
Manufacturer : PARTRON Co., Ltd.
Date of Test(s) : 2015.08.11 ~ 2015.08.20
Date of Issue : 2015.08.20

In the configuration tested, the EUT complied with the standards specified above.

Tested By:



Date:

2015.08.20

Jaeha Chung

Approved By:



Date:

2015.08.20

Hyunchae You

The results shown in this test report refer only to the sample(s) tested unless otherwise stated. This test report cannot be reproduced, except in full, without prior written permission of the Company.

INDEX

<u>TABLE OF CONTENTS</u>	Page
1. General Information -----	3
2. Field Strength of Fundamental and Spurious Emission -----	6
3. 20 dB Bandwidth -----	15
4. Transmitter AC Power Line Conducted Emission -----	17

The results shown in this test report refer only to the sample(s) tested unless otherwise stated. This test report cannot be reproduced, except in full, without prior written permission of the Company.

1. General Information

1.1. Testing laboratory

SGS Korea Co., Ltd. (Gunpo Laboratory)

- Wireless Div. 2FL, 10-2, LS-ro 182beon-gil, Gunpo-si, Gyeonggi-do, Korea, 435-837

All SGS services are rendered in accordance with the applicable SGS conditions of service available on request and accessible at <http://www.sgs.com/en/Terms-and-Conditions.aspx>.

Phone No. : +82 31 688 0901

Fax No. : +82 31 688 0921

1.2. Details of applicant

Applicant : PARTRON Co., Ltd.

Address : 22, Samsung 1-ro 2-gil, Hwaseong-Si, Gyeonggi-Do, Korea

Contact Person : Jeong, Hae-Young

Phone No. : + 82 31 201 7800

1.3. Description of EUT

Kind of Product	Wireless Charging Pad
Model Name	PTC-100
Power Supply	DC 5 V (AC 100 V ~ 240 V Travel Adaptor)
Frequency Range	115 kHz ~ 205 kHz
Operating Conditions	-20 °C ~ 60 °C
Antenna Type	Inductive loop coil antenna
H/W Version	Ver2.3
S/W Version	Ver P.1.0.6

The results shown in this test report refer only to the sample(s) tested unless otherwise stated. This test report cannot be reproduced, except in full, without prior written permission of the Company.

SGS Korea Co., Ltd. (Gunpo Laboratory) 4, LS-ro 182beon-gil, Gunpo-si, Gyeonggi-do, Korea, 435-040 <http://www.sgsgroup.kr>

1.4. Test Equipment List

Equipment	Manufacturer	Model	S/N	Cal Date	Cal Interval	Cal Due.
Spectrum Analyzer	R&S	FSV30	100768	Mar. 24, 2015	Annual	Mar. 24, 2016
Signal Generator	R&S	SMBV100A	255834	Jun. 22, 2015	Annual	Jun. 22, 2016
Signal Generator	R&S	E8257D	MY51501169	Jul. 13, 2015	Annual	Jul. 13, 2016
DC Power Supply	Agilent	U8002A	MY48490027	Dec. 22, 2014	Annual	Dec. 22, 2015
Preamplifier	H.P.	8447F	2944A03909	Aug. 27, 2014	Annual	Aug. 27, 2015
Test Receiver	R&S	ESU26	100109	Mar. 03, 2015	Annual	Mar. 03, 2016
Test Receiver	R&S	ESCI 7	100911	Dec. 24, 2014	Annual	Dec. 24, 2015
Loop Antenna	R&S	HFH2-Z2	100118	Jun. 04, 2015	Biennial	Jun. 04, 2017
Bilog Antenna	Schwarzbeck Mess-Elektronik	VULB9163	396	Jun. 18, 2015	Biennial	Jun. 18, 2017
Two-Line V-Network	R&S	ENV216	100190	Dec. 25, 2014	Annual	Dec. 25, 2015
Antenna Master	INN-CO	MM4000	N/A	N.C.R.	N/A	N.C.R.
Turn Table	INN-CO	DS 1200 S	N/A	N.C.R.	N/A	N.C.R.
Anechoic Chamber	SY Corporation	L × W × H (9.6 m × 6.4 m × 6.6 m)	N/A	N.C.R.	N/A	N.C.R.
Shield Room	SY Corporation	L × W × H (6.5 m × 3.5 m × 3.5 m)	N/A	N.C.R.	N/A	N.C.R.

1.5. Sample calculation

Where relevant, the following sample calculation is provided:

Field strength level (dB μ V/m) = Measured level (dB μ V) + Antenna factor (dB) + Cable loss (dB) – amplifier gain (dB)

The results shown in this test report refer only to the sample(s) tested unless otherwise stated. This test report cannot be reproduced, except in full, without prior written permission of the Company.

1.6. Worst case of test configurations

In order to check all kinds of possible configurations, EUT was evaluated with appropriate client and under each charging condition as below table.

EUT configuration	Description
Charging Mode with client device (Galaxy Note 4 : SM-N920U FCC ID : A3LSMN910U)	Less than 1 % of battery
	Less than 50 % of battery
	100 % full charging of battery

1.7. Summary of Test Results

The EUT has been tested according to the following specifications:

APPLIED STANDARD: FCC Part 15 Subpart C §15.209		
Section in FCC Part 15 Subpart C	Test Item	Result
15.209 15.209(a)	Radiated emission, Spurious Emission and Field Strength of Fundamental	Complied
2.1049	20 dB Bandwidth	Complied
15.207	Transmitter AC Power Line Conducted Emission	Complied

1.8. Test Report Revision

Revision	Report number	Date of Issue	Description
0	F690501/RF-RTL009017	2015.08.20	Initial

The results shown in this test report refer only to the sample(s) tested unless otherwise stated. This test report cannot be reproduced, except in full, without prior written permission of the Company.

2. Field Strength of Fundamental and Spurious Emission

2.1. Test Setup

The diagram below shows the test setup that is utilized to make the measurements for emission from 9 kHz to 30 MHz Emissions.

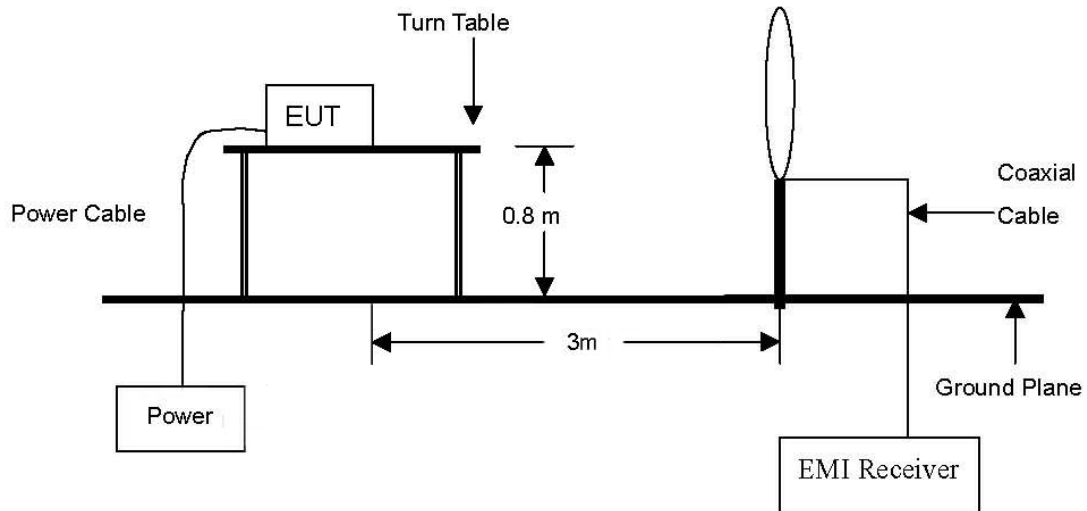

The diagram below shows the test setup that is utilized to make the measurements for emission from 30 MHz to 1 GHz Emissions.

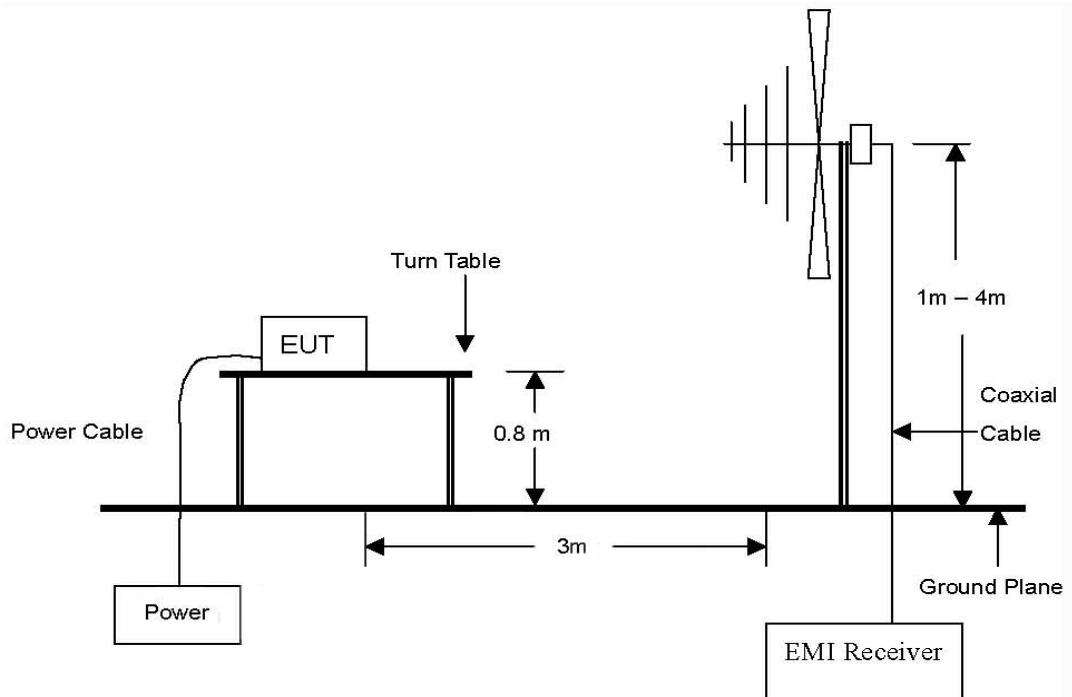

The results shown in this test report refer only to the sample(s) tested unless otherwise stated. This test report cannot be reproduced, except in full, without prior written permission of the Company.

2.2. Limit

2.2.1. Radiated emission limits, general requirements

According to §15.209 (a), Except as provided elsewhere in this Subpart, the emissions from an intentional radiator shall not exceed the field strength levels specified in the following table:

Frequency (MHz)	Field Strength (microvolts/meter)	Measurement Distance (meter)
0.009 - 0.490	2 400/F(kHz)	300
0.490 - 1.705	24 000/F(kHz)	30
1.705 - 30.0	30	30
30 - 88	100**	3
88 - 216	150**	3
216 - 960	200**	3
Above 960	500	3

** Except as provided in paragraph (g), fundamental emissions from intentional radiators operating under this Section shall not be located in the frequency bands 54-72 MHz, 76-88 MHz, 174-216 MHz or 470-806 MHz. However, operation within these frequency bands is permitted under other sections of this Part, e.g., Sections 15.231 and 15.241

The results shown in this test report refer only to the sample(s) tested unless otherwise stated. This test report cannot be reproduced, except in full, without prior written permission of the Company.

2.3. Test Procedures

Radiated emissions from the EUT were measured according to the dictates of ANSI C63.4:2009

2.3.1. Test Procedures for emission from 9 kHz to 30 MHz

- a. The EUT was placed on the top of a rotating table 0.8 meters above the ground at a 3 meter anechoic chamber test site. The table was rotated 360 degrees to determine the position of the highest radiation.
- b. Then antenna is a loop antenna is fixed at one meter above the ground to determine the maximum value of the field strength. Both parallel and perpendicular of the antenna are set to make the measurement.
- c. For each suspected emission, the EUT was arranged to its worst case and then the table was turned from 0 degrees to 360 degrees to find the maximum reading.
- d. The test-receiver system was set to Peak Detect Function and Specified Bandwidth with Maximum Hold Mode.

2.3.2. Test Procedures for emission from 30 MHz to 1 000 MHz

- a. The EUT was placed on the top of a rotating table 0.8 meters above the ground at a 3 meter anechoic chamber test site. The table was rotated 360 degrees to determine the position of the highest radiation.
- b. During performing radiated emission below 1 GHz, the EUT was set 3 meters away from the interference receiving antenna, which was mounted on the top of a variable-height antenna tower. During performing radiated emission above 1 GHz, the EUT was set 3 meter away from the interference-receiving antenna.
- c. The antenna is a broadband antenna, and its height is varied from one meter to four meters above the ground to determine the maximum value of the field strength. Both horizontal and vertical polarizations of the antenna are set to make the measurement.
- d. For each suspected emission, the EUT was arranged to its worst case and then the antenna was tuned to heights from 1 meter to 4 meters and the table was turned from 0 degrees to 360 degrees to find the maximum reading.
- e. The test-receiver system was set to Peak Detect Function and Specified Bandwidth with Maximum Hold Mode.
- f. If the emission level of the EUT in peak mode was 10 dB lower than the limit specified, then testing could be stopped and the peak values of the EUT would be reported. Otherwise the emissions that did not have 10 dB margin would be re-tested one by one using peak, quasi-peak or average method as specified and then reported in a data sheet.

The results shown in this test report refer only to the sample(s) tested unless otherwise stated. This test report cannot be reproduced, except in full, without prior written permission of the Company.

2.4. Field Strength of Fundamental Test Result

Ambient temperature : (24 ± 1) °C
 Relative humidity : 47 % R.H.

The following table shows the highest levels of radiated emissions on both polarizations of horizontal and vertical. The field strength of spurious emission was measured in all orthogonal EUT position and worst orthogonal position was x-axis.

Radiated Emissions			Ant.	Correction Factors		Total		FCC Limit	
Frequency (MHz)	Reading (dBμV)	Detect Mode	Pol.	Ant. (dB/m)	Cable (dB)	Actual (dBμV/m) at 3 m	Actual (dBμV/m) at 300 m	Limit (dBμV/m) at 300 m	Margin (dB)
Charging mode with client (less than 1 % battery status)									
0.135	51.60	Average	H	19.58	0.10	71.28	-8.72	25.00	33.72
Charging mode with client (less than 50 % battery status)									
0.161	50.50	Average	H	19.57	0.10	70.17	-9.83	23.47	33.30
Charging mode with client (100 % battery status)									
0.158	52.50	Average	H	19.57	0.10	72.17	-7.83	23.63	31.46

Note;

1. According to §15.31 (f)(2) 300 m Result(dBμV/m) = 3 m Result(dBμV/m) – 40log(300/3) (dBμV/m).
2. According to §15.209 (d), the measurements were tested by using Quasi peak detector except for the frequency bands 9 – 90 kHz, 110 – 490 kHz and above 1 GHz in these three bands on measurements employing an average detector.
3. The limit above was calculated based on table of §15.209 (a).

The results shown in this test report refer only to the sample(s) tested unless otherwise stated. This test report cannot be reproduced, except in full, without prior written permission of the Company.

2.5. Spurious Emission Test Result

Ambient temperature : (24 ± 1) °C
 Relative humidity : 47 % R.H.

The following table shows the highest levels of radiated emissions on both polarizations of horizontal and vertical.

Charging mode with client device (less than 1 % battery status)

-Below 30 MHz

Radiated Emissions			Ant.	Correction Factors		Total		FCC Limit	
Frequency (MHz)	Reading (dB μ V)	Detect Mode	Pol.	Ant. (dB/m)	Cable (dB)	Actual (dB μ V/m) at 3 m	Actual (dB μ V/m) at 300 m	Limit (dB μ V/m) at 300 m	Margin (dB)
0.038	33.80	Average	H	19.70	0.12	53.62	-26.38	36.01	62.39
0.076	26.90	Average	H	19.65	0.10	46.65	-33.35	29.99	63.34
0.084	16.10	Average	H	19.63	0.10	35.83	-44.17	29.12	73.29

Radiated Emissions			Ant.	Correction Factors		Total		FCC Limit	
Frequency (MHz)	Reading (dB μ V)	Detect Mode	Pol.	Ant. (dB/m)	Cable (dB)	Actual (dB μ V/m) at 3 m	Actual (dB μ V/m) at 30 m	Limit (dB μ V/m) at 30 m	Margin (dB)
1.059	39.00	Quasi Peak	H	19.40	0.31	58.71	18.71	27.11	8.40
2.364	44.60	Quasi Peak	H	19.33	0.37	64.30	24.30	29.54	5.24

The results shown in this test report refer only to the sample(s) tested unless otherwise stated. This test report cannot be reproduced, except in full, without prior written permission of the Company.

-Above 30 MHz

Radiated Emissions			Ant.	Correction Factors		Total	FCC Limit	
Frequency (MHz)	Reading (dB μ V)	Detect Mode	Pol.	AF (dB/m)	AMP + CL (dB)	Actual (dB μ V/m) at 3 m	Limit (dB μ V/m) at 3 m	Margin (dB)
37.80	49.00	Peak	V	13.65	-26.76	35.89	40.00	4.11
43.94	47.70	Peak	V	14.54	-26.67	35.57	40.00	4.43
54.90	38.70	Peak	H	15.20	-26.48	27.42	40.00	12.58
60.07	47.50	Peak	V	12.85	-26.39	33.96	40.00	6.04
232.08	40.60	Peak	V	13.18	-24.47	29.31	46.00	16.69
234.67	42.10	Peak	H	12.80	-24.45	30.45	46.00	15.55
Above 300.00	Not Detected	-	-	-	-	-	-	-

The results shown in this test report refer only to the sample(s) tested unless otherwise stated. This test report cannot be reproduced, except in full, without prior written permission of the Company.

Charging mode with client device (less than 50 % battery status)
-Below 30 MHz

Radiated Emissions			Ant.	Correction Factors		Total		FCC Limit	
Frequency (MHz)	Reading (dB μ V)	Detect Mode	Pol.	Ant. (dB/m)	Cable (dB)	Actual (dB μ V/m) at 3 m	Actual (dB μ V/m) at 300 m	Limit (dB μ V/m) at 300 m	Margin (dB)
0.028	26.60	Average	H	19.75	0.13	46.48	-33.52	38.66	72.18
0.056	22.70	Average	H	19.69	0.11	42.50	-37.50	32.64	70.14

Radiated Emissions			Ant.	Correction Factors		Total		FCC Limit	
Frequency (MHz)	Reading (dB μ V)	Detect Mode	Pol.	Ant. (dB/m)	Cable (dB)	Actual (dB μ V/m) at 3 m	Actual (dB μ V/m) at 30 m	Limit (dB μ V/m) at 30 m	Margin (dB)
0.772	37.30	Quasi Peak	H	19.40	0.25	56.95	16.95	29.85	12.90
2.397	45.10	Quasi Peak	H	19.33	0.37	64.80	24.80	29.54	4.74

-Above 30 MHz

Radiated Emissions			Ant.	Correction Factors		Total	FCC Limit	
Frequency (MHz)	Reading (dB μ V)	Detect Mode	Pol.	AF (dB/m)	AMP + CL (dB)	Actual (dB μ V/m) at 3 m	Limit (dB μ V/m) at 3 m	Margin (dB)
33.27	45.40	Peak	V	13.02	-26.81	31.61	40.00	8.39
42.09	48.30	Peak	V	14.27	-26.70	35.87	40.00	4.13
54.49	38.50	Peak	H	15.25	-26.49	27.26	40.00	12.74
59.55	47.30	Peak	V	12.94	-26.40	33.84	40.00	6.16
139.73	43.40	Peak	H	9.58	-25.54	27.44	43.50	16.06
234.75	41.10	Peak	V	13.30	-24.45	29.95	46.00	16.05
Above 300.00	Not Detected	-	-	-	-	-	-	-

The results shown in this test report refer only to the sample(s) tested unless otherwise stated. This test report cannot be reproduced, except in full, without prior written permission of the Company.

Charging mode with client device (100 % battery status)
-Below 30 MHz

Radiated Emissions			Ant.	Correction Factors		Total		FCC Limit	
Frequency (MHz)	Reading (dB μ V)	Detect Mode	Pol.	Ant. (dB/m)	Cable (dB)	Actual (dB μ V/m) at 3 m	Actual (dB μ V/m) at 300 m	Limit (dB μ V/m) at 300 m	Margin (dB)
0.035	29.40	Average	H	19.70	0.13	49.23	-30.77	36.72	67.49
0.071	22.20	Average	H	19.66	0.11	41.97	-38.03	30.58	68.61
0.107	23.00	Quasi Peak	H	19.60	0.09	42.69	-37.31	27.02	64.33

Radiated Emissions			Ant.	Correction Factors		Total		FCC Limit	
Frequency (MHz)	Reading (dB μ V)	Detect Mode	Pol.	Ant. (dB/m)	Cable (dB)	Actual (dB μ V/m) at 3 m	Actual (dB μ V/m) at 30 m	Limit (dB μ V/m) at 30 m	Margin (dB)
1.194	42.30	Quasi Peak	H	19.39	0.32	62.01	22.01	26.06	4.05
2.377	46.50	Quasi Peak	H	19.33	0.37	66.20	26.20	29.54	3.34

-Above 30 MHz

Radiated Emissions			Ant.	Correction Factors		Total	FCC Limit	
Frequency (MHz)	Reading (dB μ V)	Detect Mode	Pol.	AF (dB/m)	AMP + CL (dB)	Actual (dB μ V/m) at 3 m	Limit (dB μ V/m) at 3 m	Margin (dB)
33.07	44.90	Peak	V	12.99	-26.82	31.07	40.00	8.93
38.04	48.80	Peak	V	13.69	-26.76	35.73	40.00	4.27
60.31	47.60	Peak	V	12.79	-26.39	34.00	40.00	6.00
139.73	42.30	Peak	H	9.58	-25.54	26.34	43.50	17.16
233.94	40.00	Peak	V	13.26	-24.45	28.81	46.00	17.19
234.27	41.50	Peak	H	12.78	-24.45	29.83	46.00	16.17
Above 300.00	Not Detected	-	-	-	-	-	-	-

The results shown in this test report refer only to the sample(s) tested unless otherwise stated. This test report cannot be reproduced, except in full, without prior written permission of the Company.

Note;

1. According to §15.31 (f)(2),
 - 300 m Result(dB μ V/m) = 3 m Result(dB μ V/m) – 40log(300/3) (dB μ V/m)
 - 30 m Result(dB μ V/m) = 3 m Result(dB μ V/m) – 40log(30/3) (dB μ V/m)
2. According to field strength table of general requirement in §15.209 (a), field strength limits below 1.705 MHz were calculated as below.
 - 9 kHz to 490 kHz : 20log(2 400 / F (kHz)) at 300 m (dB μ V/m)
 - 490 kHz to 1 705 kHz : 20log(24 000 / F (kHz)) at 30 m (dB μ V/m)
3. According to §15.209 (d), the measurements were tested by using Quasi peak detector except for the frequency bands 9 – 90 kHz, 110 – 490 kHz and above 1 GHz in these three bands on measurements employing an average detector.
4. All results above 30 MHz are peak detector.

The results shown in this test report refer only to the sample(s) tested unless otherwise stated. This test report cannot be reproduced, except in full, without prior written permission of the Company.

3. 20 dB Bandwidth

3.1. Test Setup

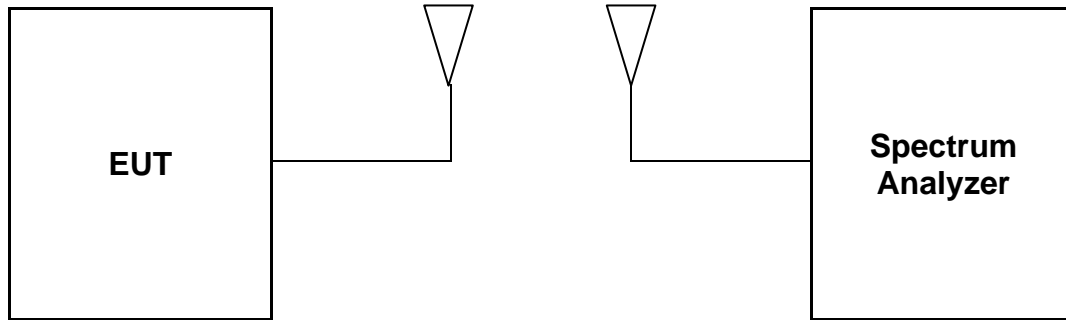

3.2. Limit

None; for reporting purposed only

3.3. Test Procedure

20 dB Bandwidth

- a. Span = approximately 2 to 3 times the 20 dB bandwidth, RBW = greater than 1 % of the 20 dB bandwidth, VBW = RBW, Sweep = auto, Detector = peak, Trace = max hold.
- b. The marker-to-peak function to set the mark to the peak of the emission. Use the marker-delta function to measure 20 dB down one side of the emission. Reset the function, and move the marker to the other side of the emission, until it is (as close as possible to) even with the reference marker level. The marker-delta reading at this point is 20 dB bandwidth of the emission.

The results shown in this test report refer only to the sample(s) tested unless otherwise stated. This test report cannot be reproduced, except in full, without prior written permission of the Company.

3.4. Test Result

Ambient temperature : (24 ± 1) °C
 Relative humidity : 47 % R.H.

EUT status	20 dB Bandwidth (kHz)	Limit
With client device (100 % of battery)	0.282	Reporting proposed only

20 dB Bandwidth

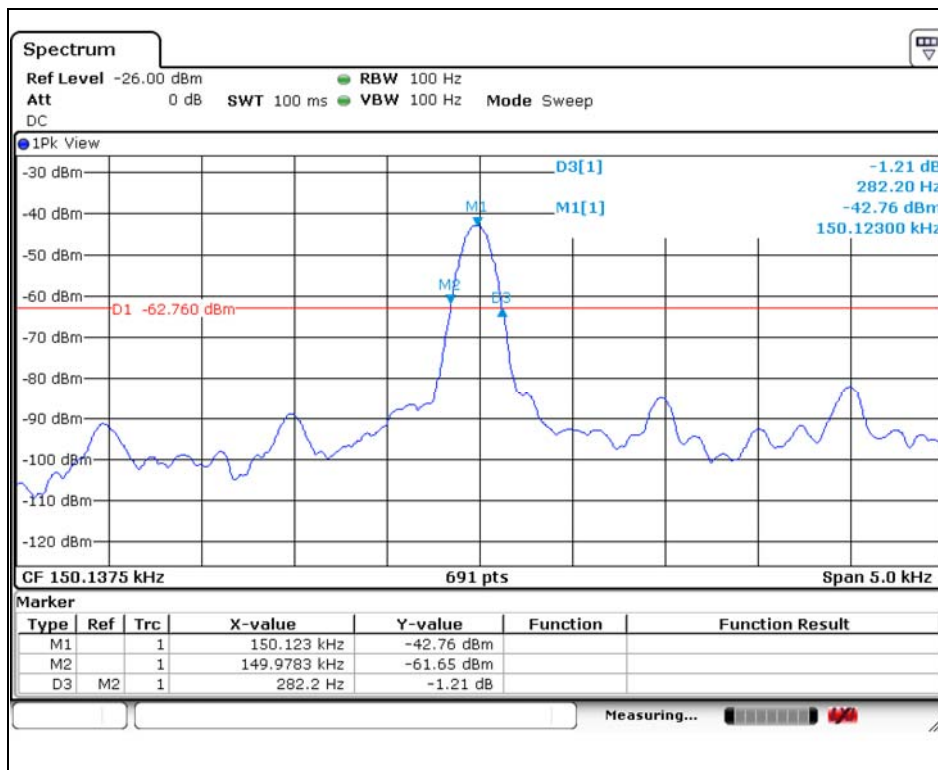

The results shown in this test report refer only to the sample(s) tested unless otherwise stated. This test report cannot be reproduced, except in full, without prior written permission of the Company.

4. Transmitter AC Power Line Conducted Emission

4.1. Test Setup

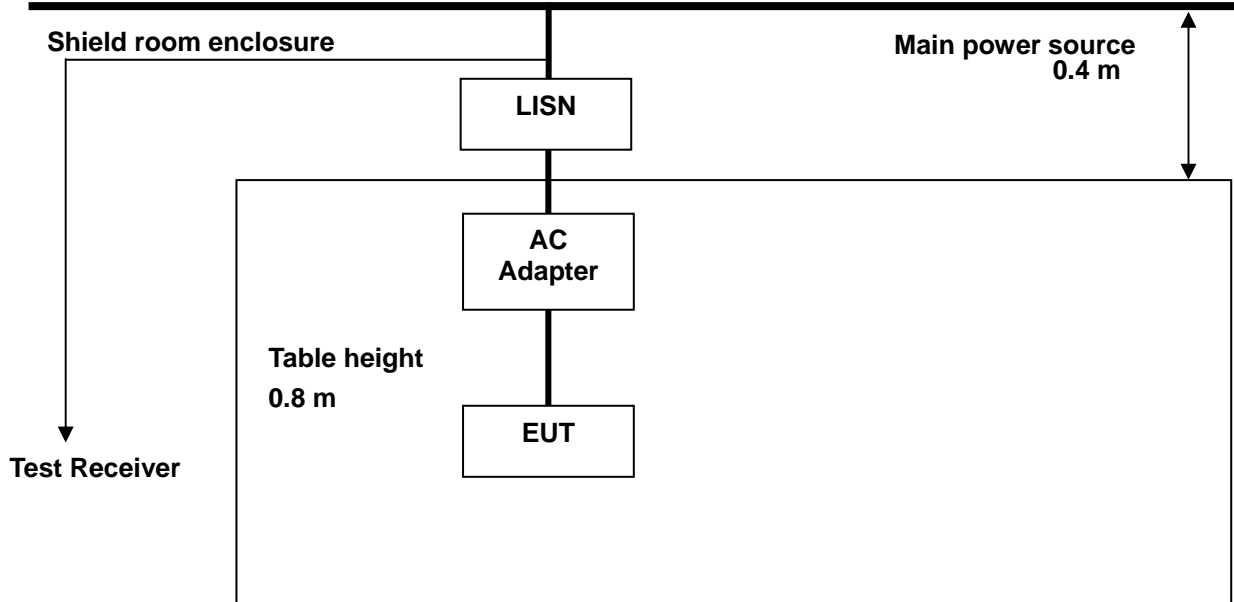

4.2. Limit

According to §15.207(a) for an intentional radiator that is designed to be connected to the public utility (AC) power line, the radio frequency voltage that is conducted back onto the AC power line on any frequency or frequencies, within the band 150 kHz to 30 MHz, shall not exceed the limits in the following table, as measured using a 50 μ H / 50 ohm line impedance stabilization network (LISN).

Compliance with the provision of this paragraph shall be on the measurement of the radio frequency voltage between each power line and ground at the power terminal. The lower value applies at the boundary between the frequency ranges.

Frequency of Emission (MHz)	Conducted limit (dB μ V)	
	Quasi-peak	Average
0.15 – 0.50	66 - 56*	56 - 46*
0.50 – 5.00	56	46
5.00 – 30.0	60	50

* Decreases with the logarithm of the frequency.

The results shown in this test report refer only to the sample(s) tested unless otherwise stated. This test report cannot be reproduced, except in full, without prior written permission of the Company.

4.3. Test Procedures

AC conducted emissions from the EUT were measured according to the dictates of ANSI C63.4:2009

1. The test procedure is performed in a 6.5 m × 3.6 m × 3.6 m (L × W × H) shielded room. The EUT along with its peripherals were placed on a 1.0 m (W) × 1.5 m (L) and 0.8 m in height wooden table and the EUT was adjusted to maintain a 0.4 meter space from a vertical reference plane.
2. The EUT was connected to power mains through a line impedance stabilization network (LISN) which provides 50 ohm coupling impedance for measuring instrument and the chassis ground was bounded to the horizontal ground plane of shielded room.
3. All peripherals were connected to the second LISN and the chassis ground also bounded to the horizontal ground plane of shielded room.
4. The excess power cable between the EUT and the LISN was bundled. The power cables of peripherals were unbundled. All connecting cables of EUT and peripherals were moved to find the maximum emission.

The results shown in this test report refer only to the sample(s) tested unless otherwise stated. This test report cannot be reproduced, except in full, without prior written permission of the Company.

4.4. Test Results

The following table shows the highest levels of conducted emissions on both phase of Hot and Neutral line.

Ambient temperature : (24 ± 1) °C
 Relative humidity : 47 % R.H.
 Frequency range : 0.15 MHz – 30 MHz
 Measured Bandwidth : 9 kHz

Charging mode with Client device (100 % status)

FREQ. (MHz)	LEVEL(dB μ V)		LINE	LIMIT(dB μ V)		MARGIN(dB)	
	Q-Peak	Average		Q-Peak	Average	Q-Peak	Average
0.18	49.30	35.40	N	64.49	54.49	15.19	19.09
0.80	33.20	25.60	N	56.00	46.00	22.80	20.40
1.69	27.30	24.10	N	56.00	46.00	28.70	21.90
1.99	27.20	23.90	N	56.00	46.00	28.80	22.10
18.20	32.20	27.80	N	60.00	50.00	27.80	22.20
26.55	37.80	33.30	N	60.00	50.00	22.20	16.70
0.18	49.50	35.70	H	64.49	54.49	14.99	18.79
0.80	49.50	36.00	H	56.00	46.00	6.50	10.00
1.69	35.70	27.20	H	56.00	46.00	20.30	18.80
1.99	29.00	24.00	H	56.00	46.00	27.00	22.00
8.29	33.40	27.50	H	60.00	50.00	26.60	22.50
27.78	42.00	33.30	H	60.00	50.00	18.00	16.70

Note ;

- Line (H): Hot, Line (N): Neutral
- Charging mode with client device (1 %, 50 %, and 100 % of battery) was tested.
As worst condition, Charging mode with client device (100 %) is reported.
- The limit for Class B device(s) from 150 kHz to 30 MHz are specified in Section of the Title 47 CFR.
- Traces shown in plot were made by using a peak detector and average detector.
- Deviations to the Specifications: None.

The results shown in this test report refer only to the sample(s) tested unless otherwise stated. This test report cannot be reproduced, except in full, without prior written permission of the Company.

Test mode: (Neutral)

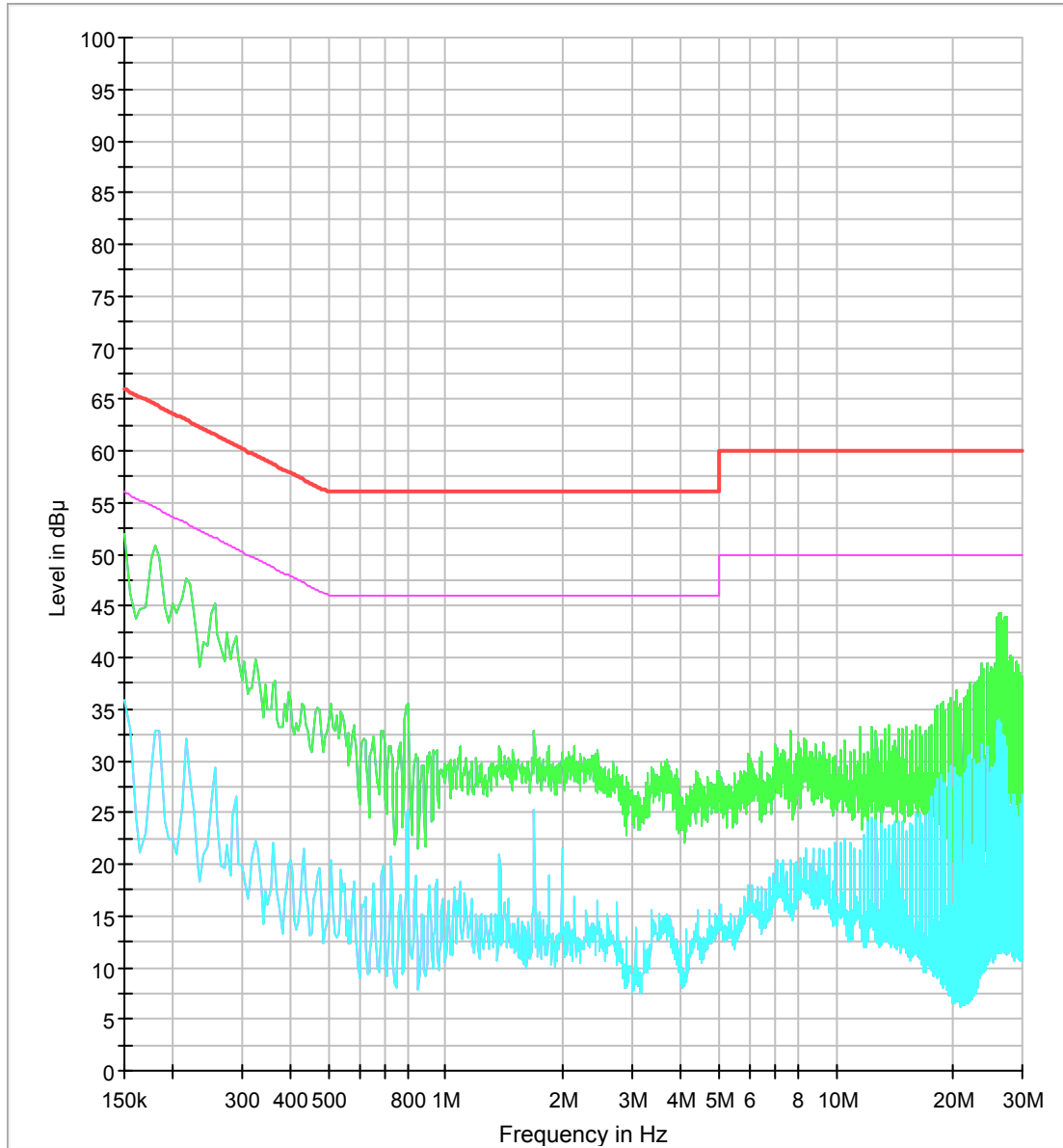

The results shown in this test report refer only to the sample(s) tested unless otherwise stated. This test report cannot be reproduced, except in full, without prior written permission of the Company.

Test mode: (Hot)

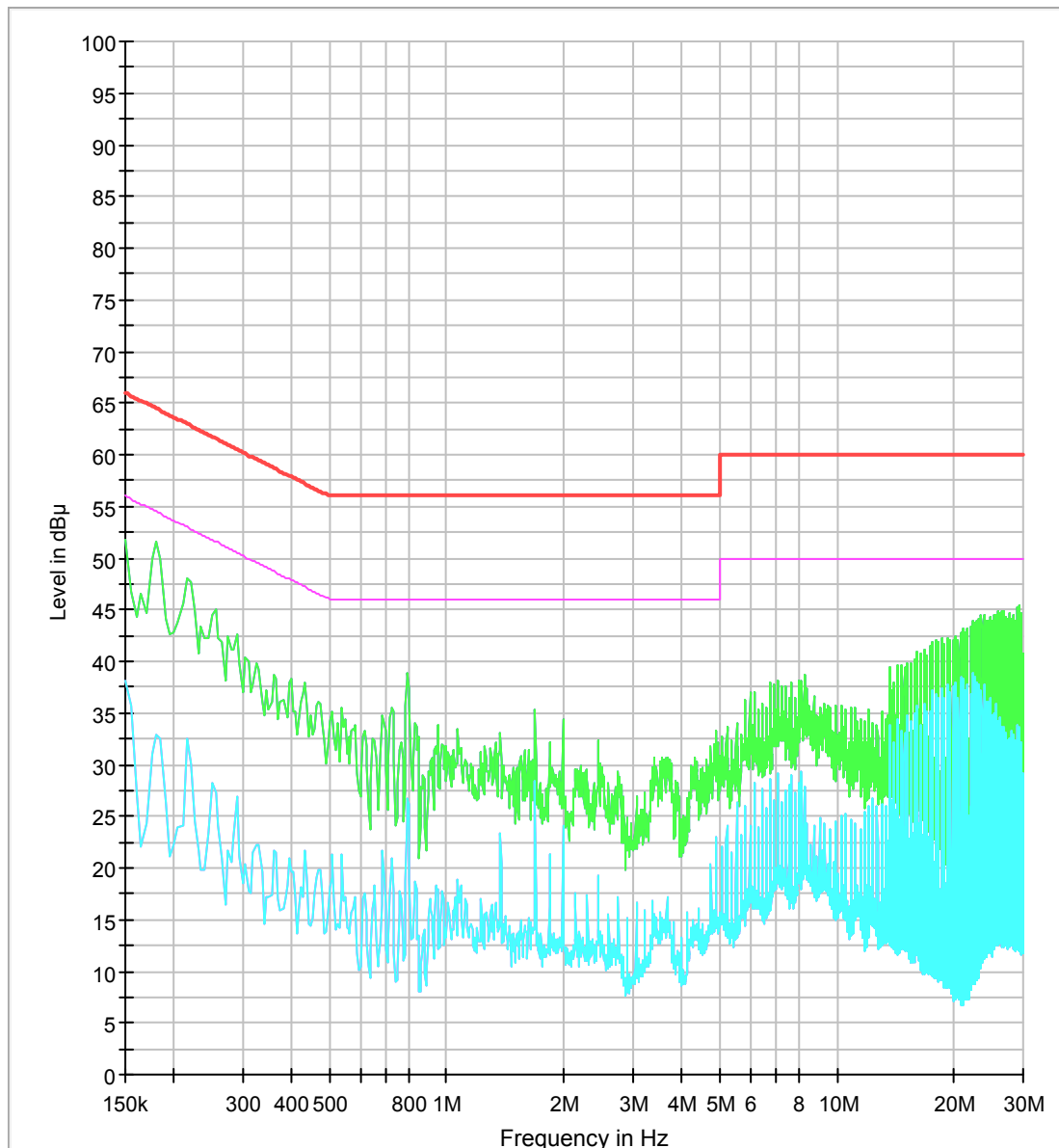

The results shown in this test report refer only to the sample(s) tested unless otherwise stated. This test report cannot be reproduced, except in full, without prior written permission of the Company.