

FCC/ISED Test Report

Product Name : Cycling computer
Trade Name : LEZYNE
Model No. : MEGA XL GPS
FCC ID. : 2AD4S-MEGAXLV104
IC ID. : 20084-MEGAXLV104

Applicant : Lezyne USA, Incorporated (FCC)
LEZYNE USA, INC. (ISED)
Address : 645 Tank Farm Road Unit F, San Luis Obispo,
California, 93401, United States (FCC)
645 Tank Farm Road, Unit F, San Luis Obispo,
CA 93401 United States Of America (ISED)

Date of Receipt : Nov. 07, 2018
Issued Date : Dec. 13, 2018
Report No. : 18B0081R-RFUSP01V00
Report Version : V1.0



The test results relate only to the samples tested.

The test report shall not be reproduced except in full without the written approval of DEKRA Testing and Certification Co., Ltd.

Test Report Certification

Issued Date : Dec. 13, 2018

Report No. : 18B0081R-RFUSP01V00



Product Name : Cycling computer
 Applicant/Manufacturer : Lezyne USA, Incorporated (FCC)
 LEZYNE USA, INC. (ISED)
 Applicant/Manufacturer Address : 645 Tank Farm Road Unit F, San Luis Obispo, California, 93401, United States (FCC)
 645 Tank Farm Road, Unit F, San Luis Obispo, CA 93401 United States Of America (ISED)

Trade Name : LEZYNE
 Model No. : MEGA XL GPS
 FCC ID. : 2AD4S-MEGAXLV104
 IC ID. : 20084-MEGAXLV104
 EUT Voltage : DC 3.7V
 Testing Voltage : AC 120V/60Hz (Power by PC)
 DC 3.7V (Power by Battery)

Applicable Standard : FCC CFR Title 47 Part 15 Subpart C Section 15.247: 2017
 RSS-GEN Issue 5 (Apr. 2018) / RSS-247 Issue 2 (Feb. 2017)
 KDB 558074 V05
 ANSI C63.10: 2013

Laboratory Name : Hsin Chu Laboratory
 Address : No.372-2, Sec. 4, Zhongxing Rd., Zhudong Township, Hsinchu County 310, Taiwan, R.O.C.
 TEL: +886-3-582-8001 / FAX: +886-3-582-8958

Test Result : Complied

Documented By : 

 (Carol Tsai / Senior Engineering Adm. Specialist)

Tested By : 

 (Mark Chang / Engineer)

Approved By : 

 (Roy Wang / Director)

Revision History

Report No.	Version	Description	Issued Date
18B0081R-RFUSP01V00	V1.0	Initial issue of report	Dec. 13, 2018

TABLE OF CONTENTS

Description	Page
1. General Information.....	6
1.1. EUT Description	6
1.2. Test Mode.....	7
1.3. Tested System Details.....	8
1.4. Configuration of tested System	8
1.5. EUT Exercise Software	9
1.6. Test Facility.....	10
1.7. List of Test Equipment.....	11
1.8. Duty cycle.....	14
1.9. Uncertainty	15
2. Conducted Emission	16
2.1. Test Setup	16
2.2. Limits	16
2.3. Test Procedure	17
2.4. Test Specification.....	17
2.5. Test Result.....	18
3. Maximum peak conducted output power.....	20
3.1. Test Setup	20
3.2. Test procedures.....	20
3.3. Limits	20
3.4. Test Specification.....	20
3.5. Test Result.....	21
4. Radiated Emission	22
4.1. Test Setup	22
4.2. Limits	23
4.3. Test Procedure	24
4.4. Test Specification.....	24
4.5. Test Result.....	25
5. RF antenna conducted test.....	35
5.1. Test Setup	35
5.2. Limits	35
5.3. Test Procedure	35
5.4. Test Specification.....	35
5.5. Test Result.....	36
6. Radiated Emission Band Edge.....	40
6.1. Test Setup	40
6.2. Limits	40
6.3. Test Procedure	40
6.4. Test Specification.....	40
6.5. Test Result.....	41
7. Occupied Bandwidth & DTS Bandwidth	53
7.1. Test Setup	53

7.2.	Limits	53
7.3.	Test Procedures	53
7.4.	Test Specification.....	53
7.5.	Test Result.....	54
8.	Power Density	58
8.1.	Test Setup	58
8.2.	Limits	58
8.3.	Test Procedures	58
8.4.	Test Specification.....	58
8.5.	Test Result.....	59
Attachment 1		61
	Test Setup Photograph.....	61
Attachment 2.....		65
	EUT External Photograph	65
Attachment 3.....		70
	EUT Internal Photograph.....	70

1. General Information

1.1. EUT Description

Product Name	Cycling computer
Trade Name	LEZYNE
Model No.	MEGA XL GPS
Frequency Range/Channel Number	2402~2480MHz / 40 Channels
Type of Modulation	GFSK

Antenna Information	
Antenna Type	PIFA Antenna
Antenna Gain	-2.4dBi

Accessories Information	
USB Cable	Shielded, 0.3m

Working Frequency of Each Channel							
Channel	Frequency	Channel	Frequency	Channel	Frequency	Channel	Frequency
Channel 00	2402 MHz	Channel 10	2422 MHz	Channel 20	2442 MHz	Channel 30	2462 MHz
Channel 01	2404 MHz	Channel 11	2424 MHz	Channel 21	2444 MHz	Channel 31	2464 MHz
Channel 02	2406 MHz	Channel 12	2426 MHz	Channel 22	2446 MHz	Channel 32	2466 MHz
Channel 03	2408 MHz	Channel 13	2428 MHz	Channel 23	2448 MHz	Channel 33	2468 MHz
Channel 04	2410 MHz	Channel 14	2430 MHz	Channel 24	2450 MHz	Channel 34	2470 MHz
Channel 05	2412 MHz	Channel 15	2432 MHz	Channel 25	2452 MHz	Channel 35	2472 MHz
Channel 06	2414 MHz	Channel 16	2434 MHz	Channel 26	2454 MHz	Channel 36	2474 MHz
Channel 07	2416MHz	Channel 17	2436 MHz	Channel 27	2456 MHz	Channel 37	2476 MHz
Channel 08	2418 MHz	Channel 18	2438 MHz	Channel 28	2458 MHz	Channel 38	2478 MHz
Channel 09	2420 MHz	Channel 19	2440 MHz	Channel 29	2460 MHz	Channel 39	2480 MHz

Note:

1. This device is a Cycling computer supports BT4.0 transmitting and BT4.0/Ant⁺/GPS receiving function..
2. Regards to the frequency band operation; the lowest 、 middle and highest frequency of channel were selected to perform the test, and then shown on this report.

1.2. Test Mode

DEKRA has verified the construction and function in typical operation. All the test modes were carried out with the EUT in transmitting operation, which was shown in this test report and defined as follows:

Test Mode	Mode 1: Transmit_Power by PC Mode 2: Transmit_Power by Battery
-----------	---

Test Items	Modulation	Channel	Result
Conducted Emission	GFSK	19	Complies
Maximum peak conducted output power	GFSK	00/19/39	Complies
Radiated Emission	GFSK	00/19/39	Complies
RF antenna conducted test	GFSK	00/19/39	Complies
Radiated Emission Radiated Emission Band Edge	GFSK	00/19/39	Complies
Occupied Bandwidth & DTS Bandwidth	GFSK	00/19/39	Complies
Power Density	GFSK	00/19/39	Complies

1.3. Tested System Details

The types for all equipment, plus descriptions of all cables used in the tested system (including inserted cards) are:

Product	Manufacturer	Model No.	Serial No.	FCC ID	Power Cord
1 Notebook PC	HP	NX6320	CNU62D1F5Y	DoC	Non-Shielded, 1.8m
2 Fixture	NA	NA	NA	DoC	--
3 Wideband Radio Communication Tester	R&S	CMW500	150246	DoC	--

1.4. Configuration of tested System

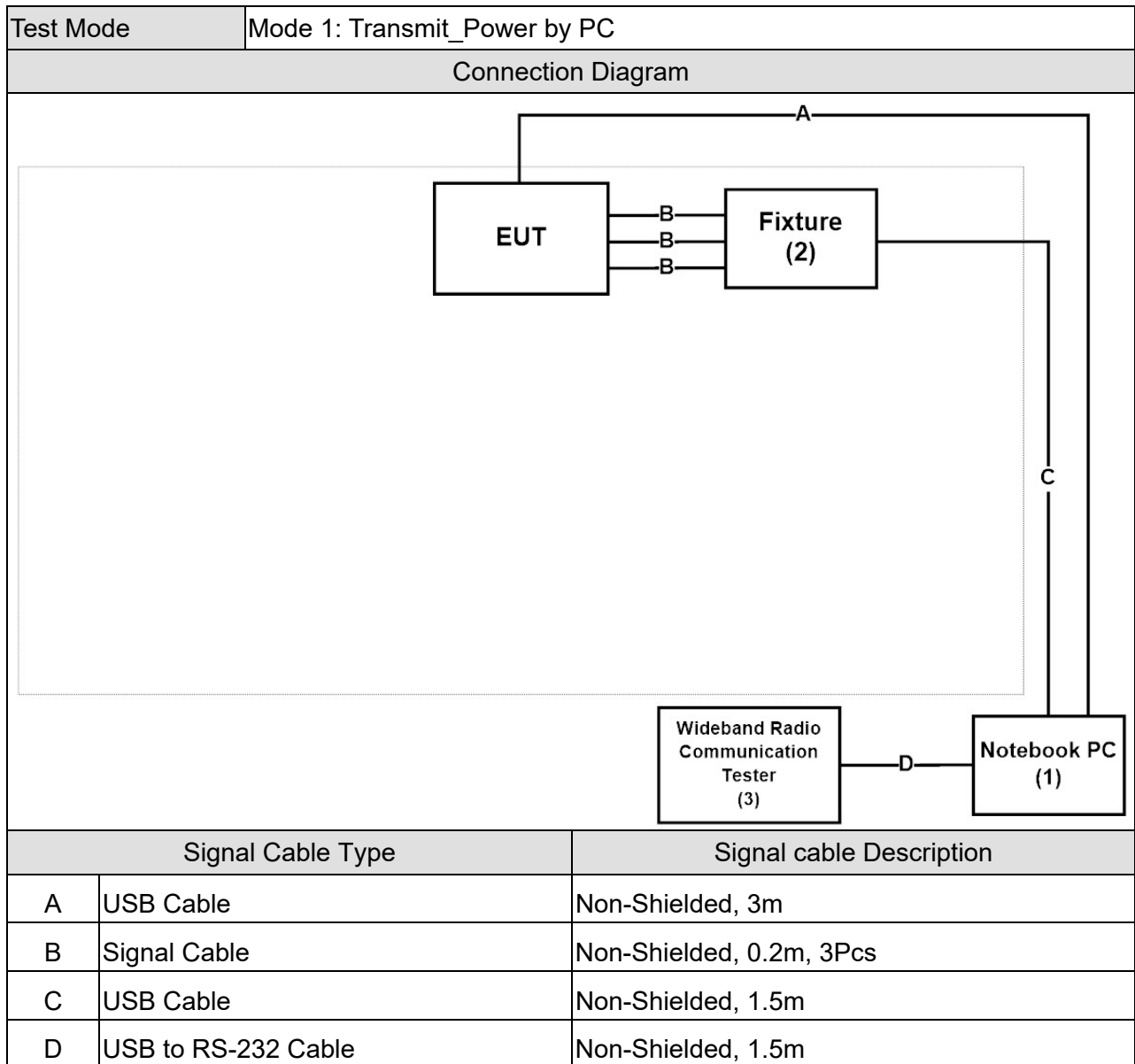

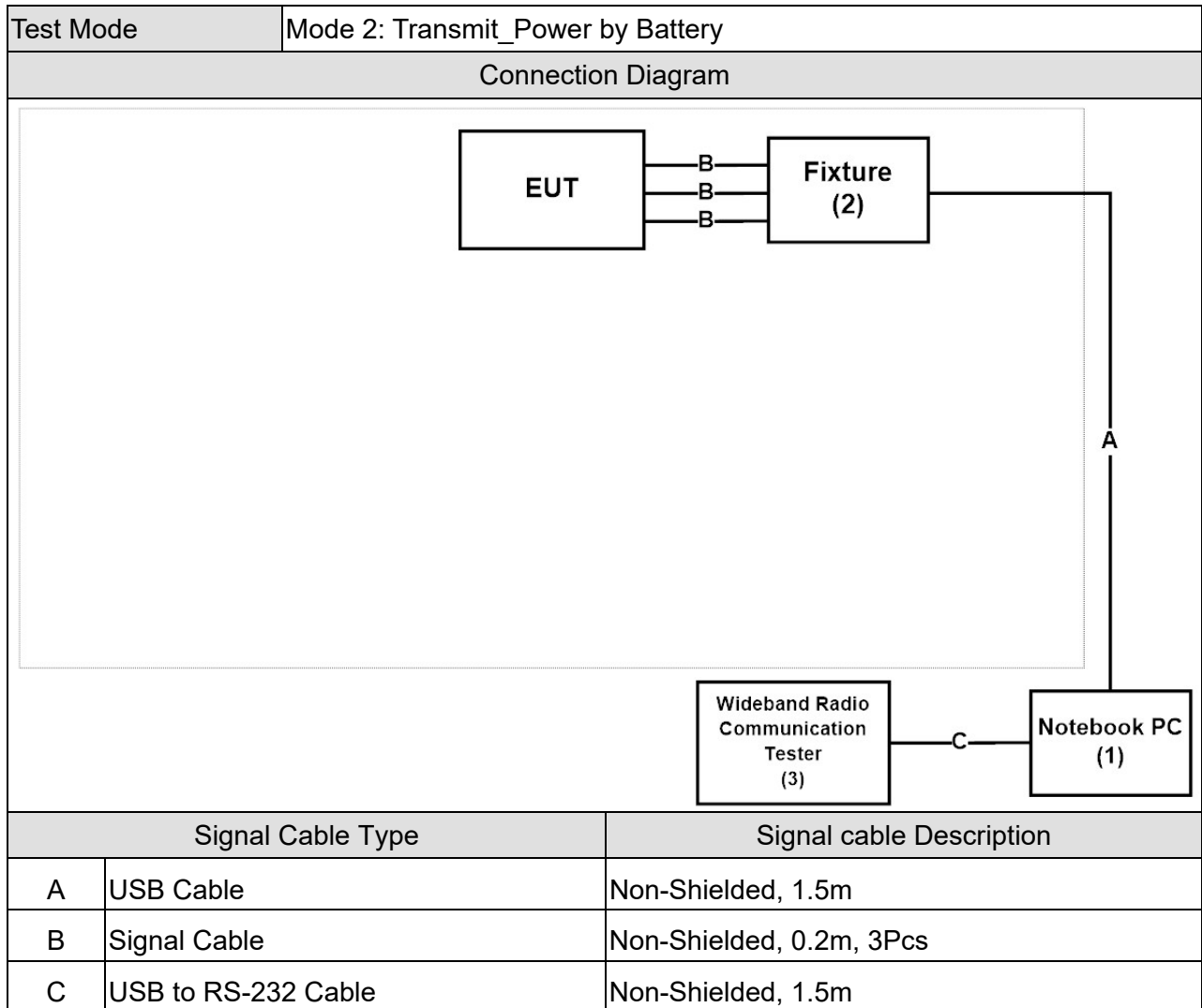

1.5. EUT Exercise Software

1	Setup the EUT as shown in Section 1.4.
2	Execute the “HCI command” on the laptop.
3	Configure the test mode, the test channel, and the data rate.
4	Press “Start TX” or “Start RX” to start the continuous transmitting or receiveing.
5	Verify that the EUT works properly.

1.6. Test Facility

Ambient conditions in the laboratory:

Items	Test Item	Required (IEC 68-1)	Actual	Test Site
Temperature (°C)	FCC PART 15 C 15.207 Conducted Emission	15 - 35	20	3
Humidity (%RH)		25 - 75	50	
Barometric pressure (mbar)		860 - 1060	950-1000	
Temperature (°C)	FCC PART 15 C 15.247 Maximum peak conducted output power	15 - 35	24	3
Humidity (%RH)		25 - 75	45	
Barometric pressure (mbar)		860 - 1060	950-1000	
Temperature (°C)	FCC PART 15 C 15.247 Radiated Emission	15 - 35	25	2
Humidity (%RH)		25 - 75	54	
Barometric pressure (mbar)		860 - 1060	950-1000	
Temperature (°C)	FCC PART 15 C 15.247 RF antenna conducted test	15 - 35	24	3
Humidity (%RH)		25 - 75	45	
Barometric pressure (mbar)		860 - 1060	950-1000	
Temperature (°C)	FCC PART 15 C 15.247 Radiated Emission Band Edge	15 - 35	25	2
Humidity (%RH)		25 - 75	50	
Barometric pressure (mbar)		860 - 1060	950-1000	
Temperature (°C)	FCC PART 15 C 15.247 Occupied Bandwidth & DTS Bandwidth	15 - 35	24	3
Humidity (%RH)		25 - 75	45	
Barometric pressure (mbar)		860 - 1060	950-1000	
Temperature (°C)	FCC PART 15 C 15.247 Power Density	15 - 35	24	3
Humidity (%RH)		25 - 75	45	
Barometric pressure (mbar)		860 - 1060	950-1000	

Note: Test site information refers to Laboratory Information.

USA : FCC Registration Number: TW3024
Canada : IC Registration Number: 22397-1 / 22397-2 / 22397-3

The related certificate for our laboratories about the test site and management system can be downloaded from DEKRA Testing and Certification Co., Ltd. Web Site:

<http://www.dekra.com.tw/english/about/certificates.aspx?bval=5>

The address and introduction of DEKRA Testing and Certification Co., Ltd. laboratories can be founded in our Web site: http://www.dekra.com.tw/index_en.aspx

If you have any comments, Please don't hesitate to contact us. Our test sites as below:

- No. 75-2, 3rd Lin, WangYe Keng, Yonghxing Tsuen, Qionglin Shiang, Hsinchu County 307, Taiwan (R.O.C.)
TEL: +886-3-592-8858 / FAX: +886-3-592-8859 E-Mail : info.tw@dekra.com
- No.372, Sec. 4, Zhongxing Rd., Zhudong Township, Hsinchu County 31061, Taiwan, R.O.C.
TEL: +886-3-582-8001 / FAX: +886-3-582-8958 E-Mail : info.tw@dekra.com
- No.372-2, Sec. 4, Zhongxing Rd., Zhudong Township, Hsinchu County 31061, Taiwan, R.O.C.
TEL: +886-3-582-8001 / FAX: +886-3-582-8958 E-Mail : info.tw@dekra.com

1.7. List of Test Equipment

Conducted Emission / SR2-H

Instrument	Manufacturer	Model No.	Serial No.	Cal. Date	Next Cal. Date
Artificial Mains Network	R&S	ENV4200	848411/010	2018/01/22	2019/01/21
Test Receiver	R&S	ESCS 30	836858/022	2018/03/30	2019/03/29
LISN	R&S	ENV216	100092	2018/07/23	2019/07/22

Maximum peak conducted output power / SR10-H

Instrument	Manufacturer	Model No.	Serial No.	Cal. Date	Next Cal. Date
High Speed Peak Power Meter Dual Input	Anritsu	ML2496A	1602004	2018/01/02	2019/01/01
Pulse Power Sensor	Anritsu	MA2411B	1531043	2018/01/02	2019/01/01
Pulse Power Sensor	Anritsu	MA2411B	1531044	2018/01/02	2019/01/01
Power Meter	Keysight	8990B	MY51000248	2018/06/07	2019/06/06
High Speed Peak Power Meter Dual Input	Anritsu	ML2496A	1602004	2018/01/02	2019/01/01

Radiated Emission / CB4-H

Instrument	Manufacturer	Model No.	Serial No.	Cal. Date	Next Cal. Date
Signal Analyzer	R&S	FSVA40	101455	2018/11/05	2019/11/04
Signal & Spectrum Analyzer	R&S	FSV40	101049	2018/01/10	2019/01/09
EXA Signal Analyzer	Keysight	N9010A	MY51440132	2018/03/05	2019/03/04
Bilog Antenna	Teseq	CBL6112D	23191	2018/06/26	2019/06/25
Horn Antenna	Schwarzbeck	BBHA 9120D	639	2018/06/01	2019/05/31
Horn Antenna	Schwarzbeck	BBHA 9170	202	2018/01/31	2019/01/30
Pre-Amplifier	Dekra	AP-025C	201801236	2018/02/26	2019/02/25
Pre-Amplifier	EMCI	EMC11830I	980366	2018/01/08	2019/01/07
Pre-Amplifier	Dekra	AP-400C	201801231	2018/12/05	2019/12/04
Horn Antenna	Schwarzbeck	BBHA 9120D	01656	2018/10/17	2019/10/16
Band Reject Filter	Micro-Tronics	BRM50702	G192	2018/04/11	2019/04/10
Signal Analyzer	R&S	FSV40	101435	2018/07/19	2019/07/18
Coaxial Cable	Suhner	SF104_SF106_SF104_SF102(23.5m)	CB4_1	2018/08/21	2019/08/20

RF antenna conducted test / SR10-H

Instrument	Manufacturer	Model No.	Serial No.	Cal. Date	Next Cal. Date
Spectrum Analyzer	Keysight	N9030B	MY57140404	2018/06/26	2019/06/25
Spectrum Analyzer	Keysight	N9010B	MY57110159	2018/05/25	2019/05/24
Spectrum Analyzer	Agilent	N9010A	US47140172	2018/07/18	2019/07/17
Signal & Spectrum Analyzer	R&S	FSV40	101049	2018/01/10	2019/01/09

Radiated Emission Band Edge / CB4-H

Instrument	Manufacturer	Model No.	Serial No.	Cal. Date	Next Cal. Date
Signal Analyzer	R&S	FSVA40	101455	2018/11/05	2019/11/04
Signal & Spectrum Analyzer	R&S	FSV40	101049	2018/01/10	2019/01/09
EXA Signal Analyzer	Keysight	N9010A	MY51440132	2018/03/05	2019/03/04
Bilog Antenna	Teseq	CBL6112D	23191	2018/06/26	2019/06/25
Horn Antenna	Schwarzbeck	BBHA 9120D	639	2018/06/01	2019/05/31
Horn Antenna	Schwarzbeck	BBHA 9170	202	2018/01/31	2019/01/30
Pre-Amplifier	Dekra	AP-025C	201801236	2018/02/26	2019/02/25
Pre-Amplifier	EMCI	EMC11830I	980366	2018/01/08	2019/01/07
Pre-Amplifier	Dekra	AP-400C	201801231	2018/12/05	2019/12/04
Horn Antenna	Schwarzbeck	BBHA 9120D	01656	2018/10/17	2019/10/16
Band Reject Filter	Micro-Tronics	BRM50702	G192	2018/04/11	2019/04/10
Signal Analyzer	R&S	FSV40	101435	2018/07/19	2019/07/18
Coaxial Cable	Suhner	SF104_SF106_SF104_SF102(23.5m)	CB4_1	2018/08/21	2019/08/20

Occupied Bandwidth & DTS Bandwidth / SR10-H

Instrument	Manufacturer	Model No.	Serial No.	Cal. Date	Next Cal. Date
Spectrum Analyzer	Keysight	N9030B	MY57140404	2018/06/26	2019/06/25
Spectrum Analyzer	Keysight	N9010B	MY57110159	2018/05/25	2019/05/24
Spectrum Analyzer	Agilent	N9010A	US47140172	2018/07/18	2019/07/17
Signal & Spectrum Analyzer	R&S	FSV40	101049	2018/01/10	2019/01/09

Power Density / SR10-H

Instrument	Manufacturer	Model No.	Serial No.	Cal. Date	Next Cal. Date
Spectrum Analyzer	Keysight	N9030B	MY57140404	2018/06/26	2019/06/25
Spectrum Analyzer	Keysight	N9010B	MY57110159	2018/05/25	2019/05/24
Spectrum Analyzer	Agilent	N9010A	US47140172	2018/07/18	2019/07/17
Signal & Spectrum Analyzer	R&S	FSV40	101049	2018/01/10	2019/01/09

Note: All equipment upon which need to calibrated are with calibration period of 1 year.

1.8. Duty cycle

Frequency	On Time (ms)	On+Off Time (ms)	Duty Cycle (%)	Duty Factor (dB)	1/T Minimum VBW (kHz)
2440	0.390	0.629	62.42%	2.05	2.560

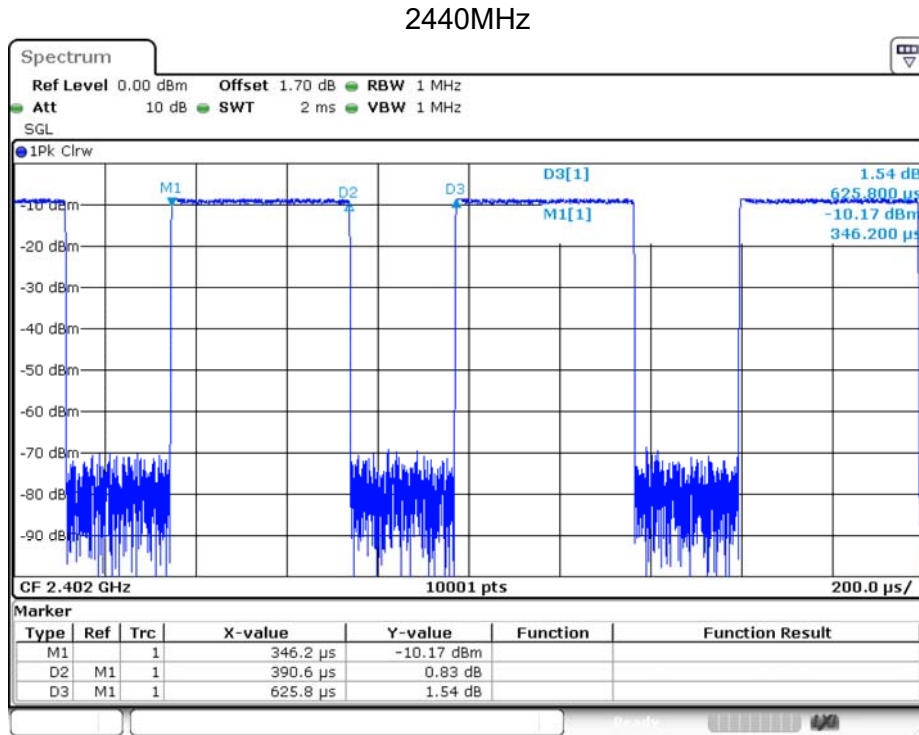

Date: 4.DEC.2018 15:05:55

1.9. Uncertainty

Test item	Uncertainty
Conducted Emission	± 2.26 dB
Maximum peak conducted output power	± 1.27 dB
Radiated Emission	30MHz~1GHz as ± 3.43 dB 1GHz~26.5GHz as ± 3.65 dB
RF antenna conducted test	± 1.27 dB
Radiated Emission Radiated Emission Band Edge	± 3.9 dB
Occupied Bandwidth & DTS Bandwidth	± 50 Hz
Power Density	± 1.27 dB

2. Conducted Emission

2.1. Test Setup

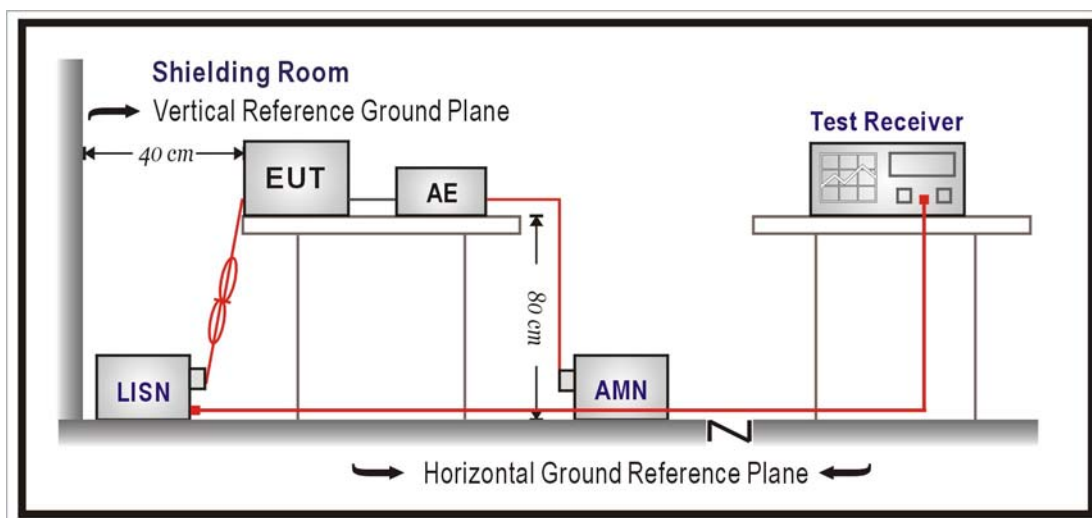

2.2. Limits

FCC Part 15 Subpart C Paragraph 15.207 Limits (dBuV)		
Frequency MHz	QP	AV
0.15 - 0.50	66 - 56	56 - 46
0.50 - 5.0	56	46
5.0 - 30	60	50

Remarks: In the above table, the tighter limit applies at the band edges.

2.3. Test Procedure

The EUT and simulators are connected to the main power through a line impedance stabilization network (L.I.S.N.). This provides a 50 ohm /50uH coupling impedance for the measuring equipment. The peripheral devices are also connected to the main power through a LISN that provides a 50ohm/50uH coupling impedance with 50ohm termination. (Please refer to the block diagram of the test setup and photographs.)

Both sides of A.C. line are checked for maximum conducted interference. In order to find the maximum emission, the relative positions of equipment and all of the interface cables must be changed according to ANSI C63.4: 2014 on conducted measurement. Conducted emissions were investigated over the frequency range from 0.15MHz to 30MHz using a receiver bandwidth of 9KHz.

2.4. Test Specification

According to FCC Part 15 Subpart C Paragraph 15.207 and ISED RSS-247.

2.5. Test Result

Site : SR2-H	Time : 2018/11/27
Limit : CISPR_B_00M_QP	Margin : 10
Probe : SR2-B127_LISN(16A)-8 - Line1	Power : AC 120V/60Hz
EUT : Cycling computer	Note : Mode 1: Transmit_Power by PC 802.15.1_BLE_2440MHz

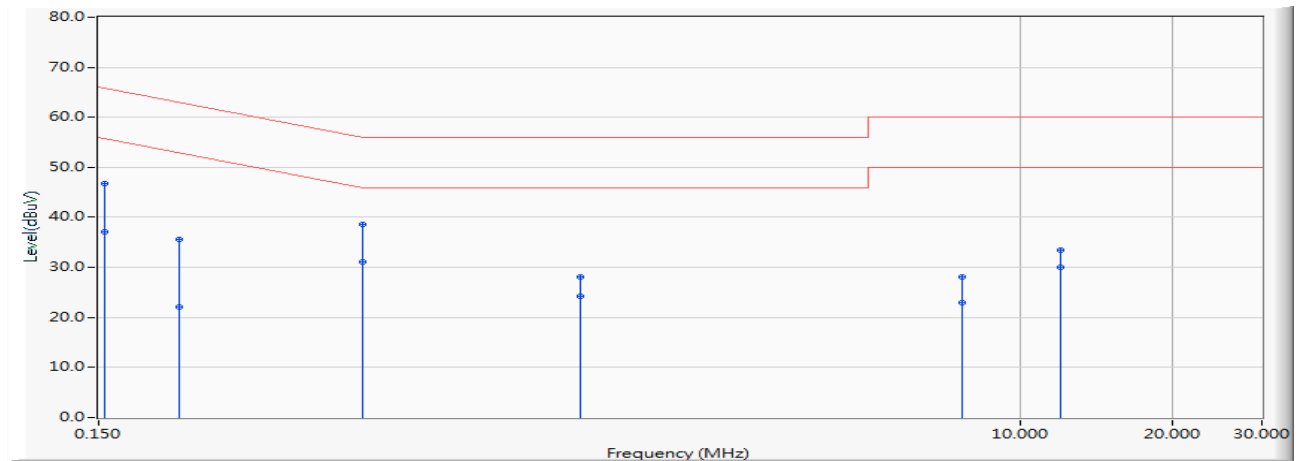

	Frequency (MHz)	Correct Factor (dB)	Reading Level (dBuV)	Measure Level (dBuV)	Margin (dB)	Limit (dBuV)	Detector Type
1	0.154	9.680	36.990	46.670	-19.116	65.786	QUASIPeAK
2	0.154	9.680	27.430	37.110	-18.676	55.786	AVERAGE
3	0.216	9.680	25.830	35.510	-27.446	62.956	QUASIPeAK
4	0.216	9.680	12.500	22.180	-30.776	52.956	AVERAGE
5	0.498	9.683	28.980	38.663	-17.376	56.039	QUASIPeAK
6	*	0.498	21.450	31.133	-14.906	46.039	AVERAGE
7	1.345	9.793	18.220	28.013	-27.987	56.000	QUASIPeAK
8	1.345	9.793	14.420	24.213	-21.787	46.000	AVERAGE
9	7.634	9.963	18.160	28.124	-31.876	60.000	QUASIPeAK
10	7.634	9.963	13.090	23.054	-26.946	50.000	AVERAGE
11	12.017	10.195	23.250	33.445	-26.555	60.000	QUASIPeAK
12	12.017	10.195	19.830	30.025	-19.975	50.000	AVERAGE

Note:

1. All Reading Levels are Quasi-Peak and average value.
2. " * ", means this data is the worst emission level.
3. Measure Level = Reading Level + Correct Factor.

Site : SR2-H	Time : 2018/11/27
Limit : CISPR_B_00M_QP	Margin : 10
Probe : SR2-B127_LISN(16A)-8 - Line2	Power : AC 120V/60Hz
EUT : Cycling computer	Note : Mode 1: Transmit_Power by PC 802.15.1_BLE_2440MHz

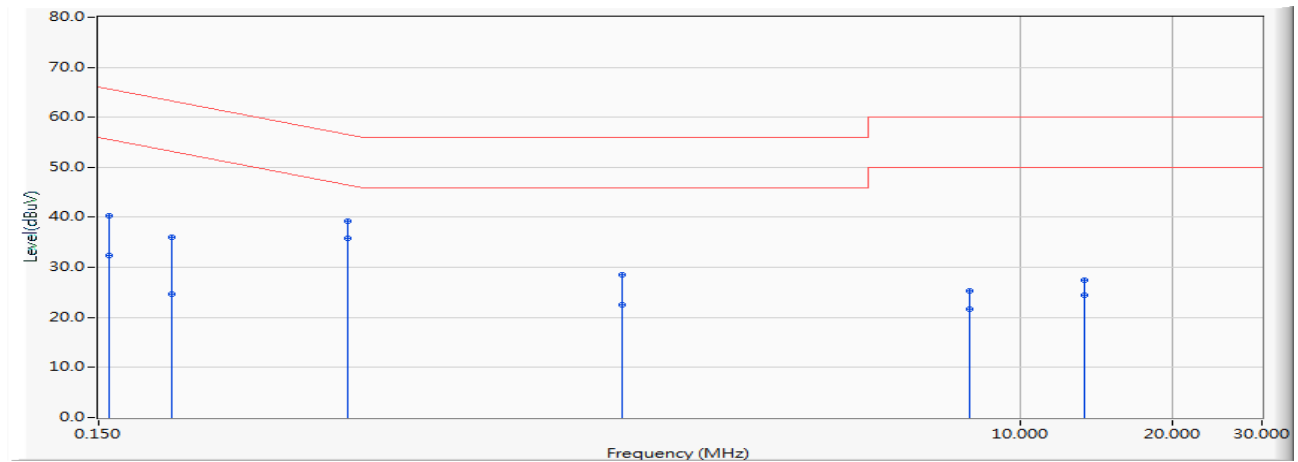

	Frequency (MHz)	Correct Factor (dB)	Reading Level (dBuV)	Measure Level (dBuV)	Margin (dB)	Limit (dBuV)	Detector Type
1	0.158	9.680	30.720	40.400	-25.178	65.578	QUASIPeAK
2	0.158	9.680	22.630	32.310	-23.268	55.578	AVERAGE
3	0.209	9.680	26.390	36.070	-27.191	63.261	QUASIPeAK
4	0.209	9.680	15.050	24.730	-28.531	53.261	AVERAGE
5	0.466	9.681	29.480	39.161	-17.417	56.578	QUASIPeAK
6	*	9.681	26.090	35.771	-10.807	46.578	AVERAGE
7	1.627	9.796	18.660	28.456	-27.544	56.000	QUASIPeAK
8	1.627	9.796	12.680	22.476	-23.524	46.000	AVERAGE
9	7.916	9.976	15.370	25.346	-34.654	60.000	QUASIPeAK
10	7.916	9.976	11.770	21.746	-28.254	50.000	AVERAGE
11	13.392	10.243	17.270	27.513	-32.487	60.000	QUASIPeAK
12	13.392	10.243	14.130	24.373	-25.627	50.000	AVERAGE

Note:

1. All Reading Levels are Quasi-Peak and average value.
2. " * ", means this data is the worst emission level.
3. Measure Level = Reading Level + Correct Factor.

3. Maximum peak conducted output power

3.1. Test Setup

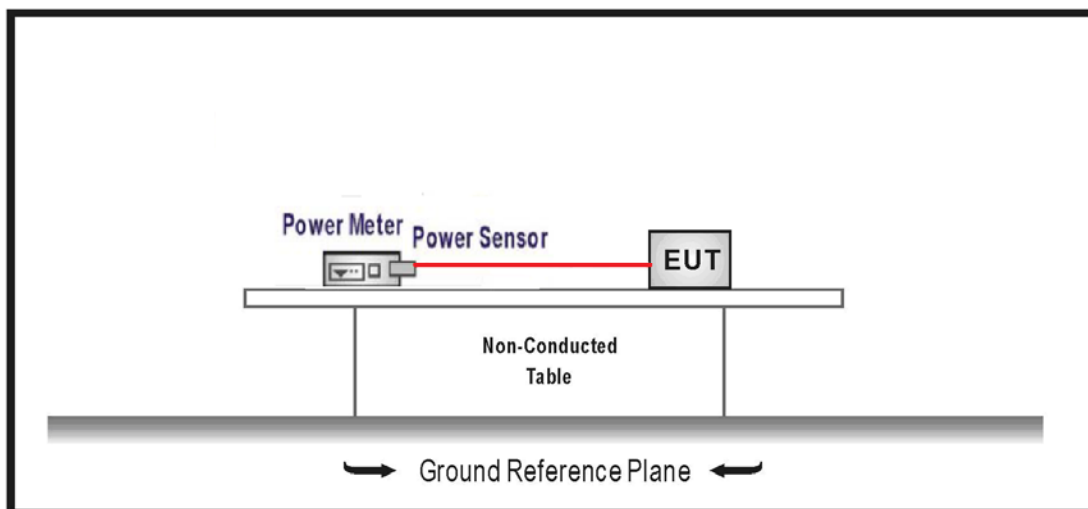

3.2. Test procedures

The EUT was setup according to ANSI C63.10: 2013; tested according to DTS test procedure of KDB558074 V05 for compliance to FCC 47CFR 15.247 requirements.

3.3. Limits

The maximum peak power shall be less 1 Watt.

3.4. Test Specification

According to FCC Part 15 Subpart C Paragraph 15.247 and ISSED RSS-247.

3.5. Test Result

Product	Cycling computer		
Test Item	Maximum peak conducted output power		
Test Mode	Mode 1: Transmit_Power by PC		
Date of Test	2018/12/04	Test Site	SR10-H

Channel No.	Frequency (MHz)	Measure Level (dBm)	Limit (dBm)
00	2402	-10.540	≤ 30
19	2440	-7.100	≤ 30
39	2480	-5.840	≤ 30

4. Radiated Emission

4.1. Test Setup

Under 30MHz Test Setup:

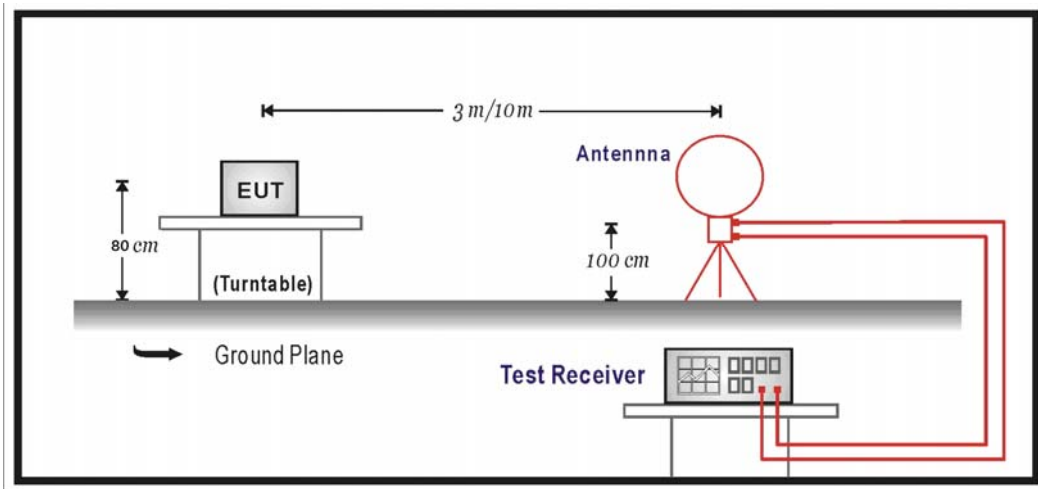

Under 1GHz Test Setup:

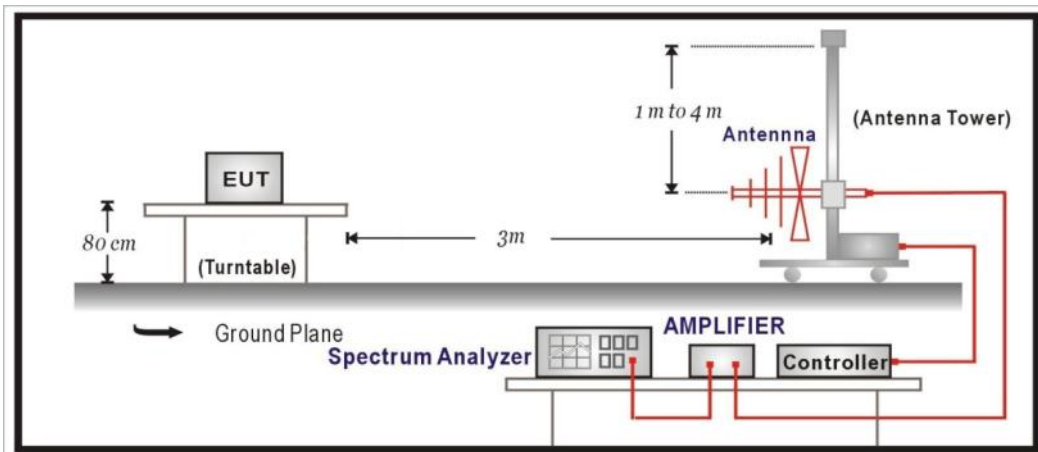

Above 1GHz Test Setup:

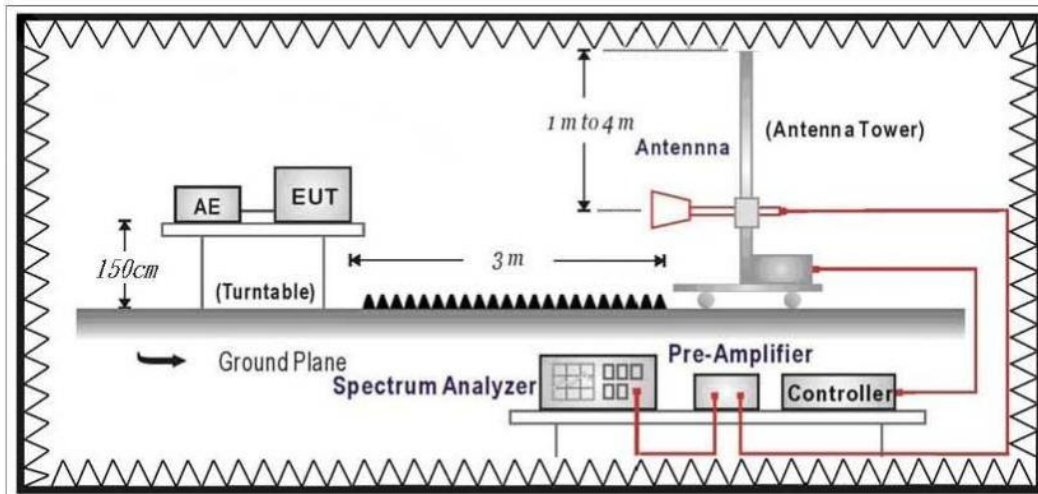

4.2. Limits

Emissions radiated outside of the specified frequency bands, except for harmonics, shall be attenuated by at least 20dB below the level of the fundamental or to the general radiated emission limits in paragraph 15.209, whichever is the lesser attenuation.

FCC Part 15 Subpart C Paragraph 15.209 Limits		
Frequency MHz	uV/m	dBuV/m
30 - 88	100	40
88 - 216	150	43.5
216 - 960	200	46
Above 960	500	54

- Remarks:
1. RF Voltage (dBuV) = 20 log RF Voltage (uV)
 2. In the Above Table, the tighter limit applies at the Radiated Emission Band Edges.
 3. Distance refers to the distance in meters between the measuring instrument antenna and the closed point of any part of the device or system.

4.3. Test Procedure

The EUT was setup according to ANSI C63.10: 2013 and tested according to DTS test procedure of KDB558074 V05 for compliance to FCC 47CFR 15.247 requirements.

The EUT and its simulators are placed on a turn table which is 0.8 or 1.5 meter above ground. The turn table can rotate 360 degrees to determine the position of the maximum emission level.

The antenna can move up and down between 1 meter and 4 meters to find out the maximum emission level.

Both horizontal and vertical polarization of the antenna are set on measurement. In order to find the maximum emission, all of the interface cables must be manipulated according to ANSI C63.10: 2013 on radiated measurement.

On any frequency or frequencies from 9KHz(include The the lowest oscillator frequency generated within the device up to the 10th harmonic) to 1000 MHz, the limits shown are based on measuring equipment employing a quasi-peak detector function and on any frequency or frequencies above 1000 MHz the radiated limits shown are based upon the use of measurement instrumentation employing an average detector function. When average radiated emission measurement are included emission measurement below 1000 MHz, there also is a limit on the radio frequency emissions, as measured using instrumentation with a peak detector function, corresponding to 20 dB above the maximum permitted average limit. The bandwidth below 1GHz setting on the field strength meter is 120 kHz and above 1GHz is 1MHz.

4.4. Test Specification

According to FCC Part 15 Subpart C Paragraph 15.247 and ISED RSS-247.

4.5. Test Result

30MHz-1GHz Spurious

Site :	CB4-H	Engineer :	Lion
Model No :	MEGA XL GPS	Test Date :	2018/12/1
Test Voltage :	AC 120V/60Hz	Polarity :	Horizontal
Test Mode :	Mode 1: Transmit Power by PC		
Note :	802.15.1_BLE_2440MHz		

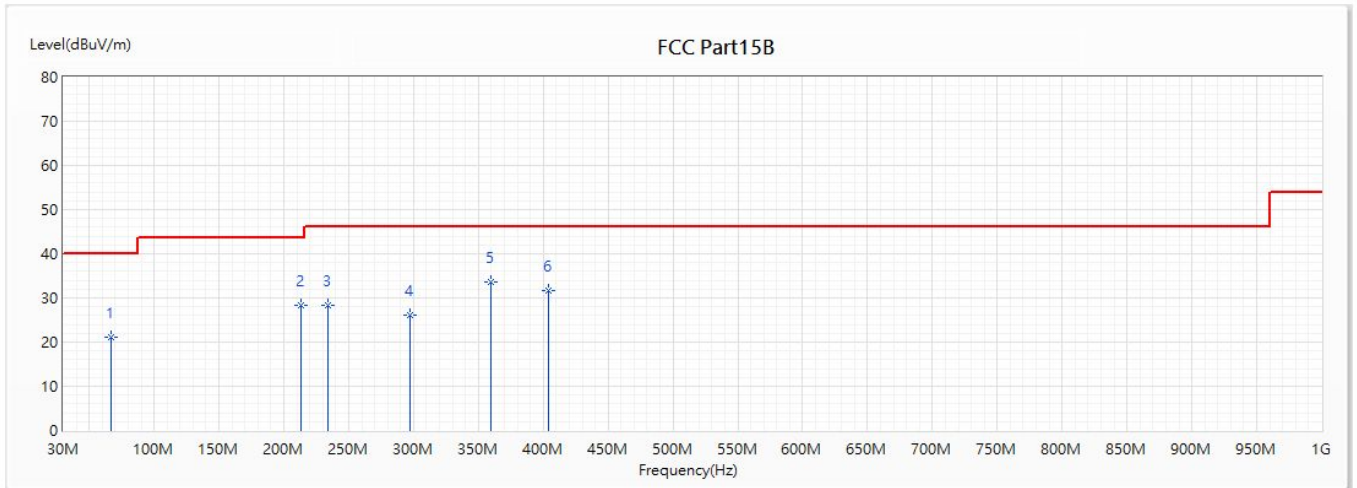

No	Frequency (MHz)	Emission Level (dBuV/m)	Limit (dBuV/m)	Margin (dB)	Reading Level (dBuV)	Correct Factor (dB)	Detector Type
1	66.618	21.10	40.00	-18.90	48.29	-27.19	QP
2	213.694	28.28	43.50	-15.22	50.85	-22.57	QP
3	233.821	28.24	46.00	-17.76	48.77	-20.53	QP
4	297.114	26.25	46.00	-19.75	45.08	-18.83	QP
* 5	359.436	33.62	46.00	-12.38	50.28	-16.66	QP
6	403.571	31.61	46.00	-14.39	47.63	-16.02	QP

Note:

1. All Reading Levels is Quasi-Peak value.
2. “ * ”, means this data is the worst emission level.
3. Measurement Level = Reading Level + Correct Factor
4. The Emission under 30MHz were not included is because their levels are too low.
5. The emission form 9KHz to 30MHz Radiated emission were not show in the test report, because Pre-scan lower than the limit line.

Site :	CB4-H	Engineer :	Lion
Model No :	MEGA XL GPS	Test Date :	2018/12/1
Test Voltage :	AC 120V/60Hz	Polarity :	Vertical
Test Mode :	Mode 1: Transmit Power by PC		
Note :	802.15.1_BLE_2440MHz		

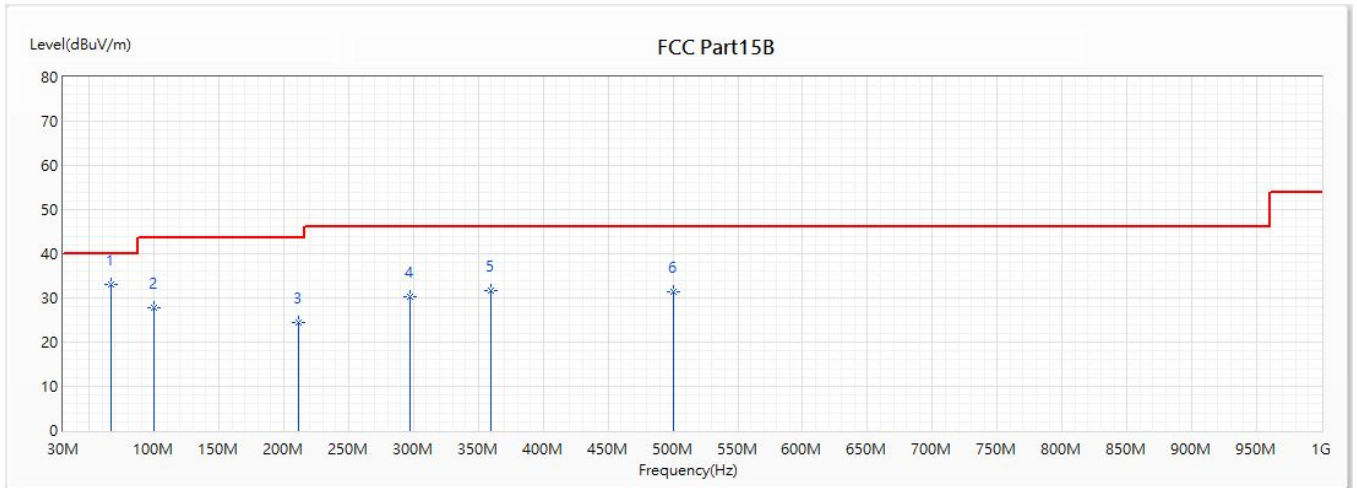

No	Frequency (MHz)	Emission Level (dBuV/m)	Limit (dBuV/m)	Margin (dB)	Reading Level (dBuV)	Correct Factor (dB)	Detector Type
* 1	66.618	32.96	40.00	-7.04	60.15	-27.19	QP
2	99.961	27.66	43.50	-15.84	50.29	-22.63	QP
3	210.905	24.57	43.50	-18.93	47.11	-22.54	QP
4	297.114	30.38	46.00	-15.62	49.21	-18.83	QP
5	359.436	31.60	46.00	-14.40	48.26	-16.66	QP
6	499.965	31.28	46.00	-14.72	45.49	-14.21	QP

Note:

1. All Reading Levels is Quasi-Peak value.
2. “ * ”, means this data is the worst emission level.
3. Measurement Level = Reading Level + Correct Factor
4. The Emission under 30MHz were not included is because their levels are too low.
5. The emission form 9KHz to 30MHz Radiated emission were not show in the test report, because Pre-scan lower than the limit line.

Site :	CB4-H	Engineer :	Lion
Model No :	MEGA XL GPS	Test Date :	2018/12/1
Test Voltage :	DC 3.7V	Polarity :	Horizontal
Test Mode :	Mode 2: Transmit Power by Battery		
Note :	802.15.1_BLE_2440MHz		

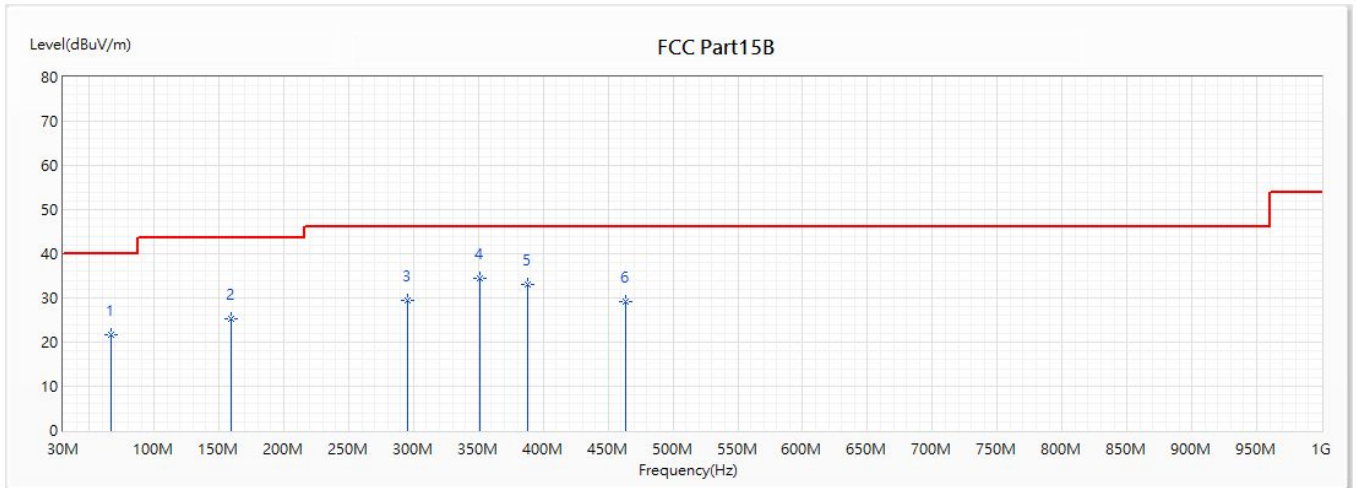

No	Frequency (MHz)	Emission Level (dBuV/m)	Limit (dBuV/m)	Margin (dB)	Reading Level (dBuV)	Correct Factor (dB)	Detector Type
1	66.618	21.72	40.00	-18.28	48.91	-27.19	QP
2	159.738	25.28	43.50	-18.22	47.30	-22.02	QP
3	295.053	29.36	46.00	-16.64	48.08	-18.72	QP
* 4	351.313	34.56	46.00	-11.44	51.51	-16.95	QP
5	387.566	32.96	46.00	-13.04	48.82	-15.86	QP
6	463.833	29.11	46.00	-16.89	44.03	-14.92	QP

Note:

1. All Reading Levels is Quasi-Peak value.
2. “ * ”, means this data is the worst emission level.
3. Measurement Level = Reading Level + Correct Factor
4. The Emission under 30MHz were not included is because their levels are too low.
5. The emission form 9KHz to 30MHz Radiated emission were not show in the test report, because Pre-scan lower than the limit line.

Site :	CB4-H	Engineer :	Lion
Model No :	MEGA XL GPS	Test Date :	2018/12/1
Test Voltage :	DC 3.7V	Polarity :	Vertical
Test Mode :	Mode 2: Transmit Power by Battery		
Note :	802.15.1_BLE_2440MHz		

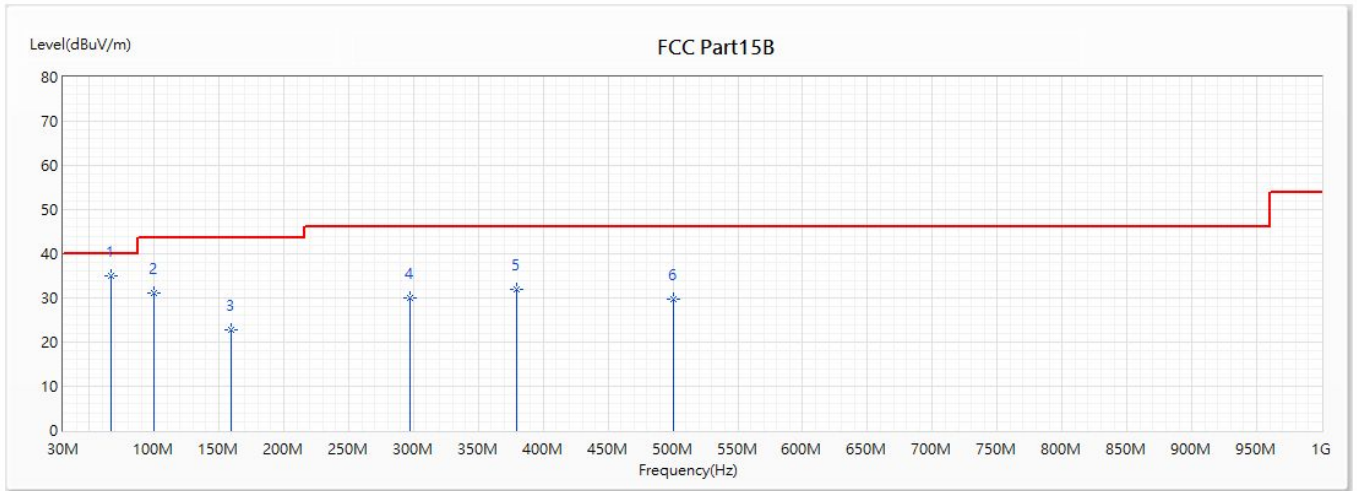

No	Frequency (MHz)	Emission Level (dBuV/m)	Limit (dBuV/m)	Margin (dB)	Reading Level (dBuV)	Correct Factor (dB)	Detector Type
* 1	66.618	34.97	40.00	-5.03	62.16	-27.19	QP
2	99.961	31.22	43.50	-12.28	53.85	-22.63	QP
3	159.738	22.69	43.50	-20.81	44.71	-22.02	QP
4	297.114	30.12	46.00	-15.88	48.95	-18.83	QP
5	379.564	31.87	46.00	-14.13	48.35	-16.48	QP
6	499.965	29.80	46.00	-16.20	44.01	-14.21	QP

Note:

1. All Reading Levels is Quasi-Peak value.
2. “ * ”, means this data is the worst emission level.
3. Measurement Level = Reading Level + Correct Factor
4. The Emission under 30MHz were not included is because their levels are too low.
5. The emission form 9KHz to 30MHz Radiated emission were not show in the test report, because Pre-scan lower than the limit line.

Harmonic & Spurious:

Site :	CB4-H	Engineer :	Lion
Model No :	MEGA XL GPS	Test Date :	2018/11/30
Test Voltage :	AC 120V/60Hz	Polarity :	Horizontal
Test Mode :	Mode 1: Transmit Power by PC		
Note :	802.15.1_BLE_2402MHz		

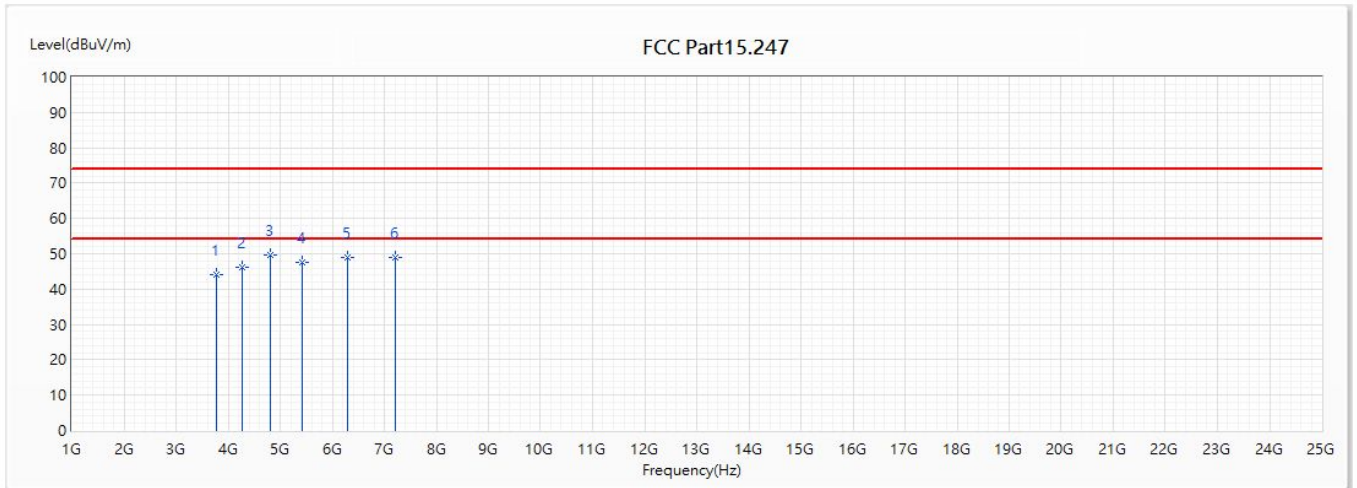

No	Frequency (MHz)	Emission Level (dBuV/m)	Limit (dBuV/m)	Margin (dB)	Reading Level (dBuV)	Correct Factor (dB)	Detector Type
1	3768	43.97	74.00	-30.03	40.24	3.73	PK
2	4266	46.05	74.00	-27.95	40.40	5.65	PK
* 3	4804	49.53	74.00	-24.47	42.34	7.19	PK
4	5414	47.61	74.00	-26.39	39.19	8.42	PK
5	6292	49.08	74.00	-24.92	37.25	11.83	PK
6	7206	49.06	74.00	-24.94	33.72	15.34	PK

Note:

1. All reading above 1GHz is performed with peak and/or average measurements as necessary.
2. “ * ”, means this data is the worst emission level.
3. Emission Level = Reading Level + Correct Factor.
4. The average measurement was not performed when the peak measured data under the limit of average detection.
5. The Emission above 13GHz were not included is because their levels are too low.

Site :	CB4-H	Engineer :	Lion
Model No :	MEGA XL GPS	Test Date :	2018/11/30
Test Voltage :	AC 120V/60Hz	Polarity :	Vertical
Test Mode :	Mode 1: Transmit Power by PC		
Note :	802.15.1_BLE_2402MHz		

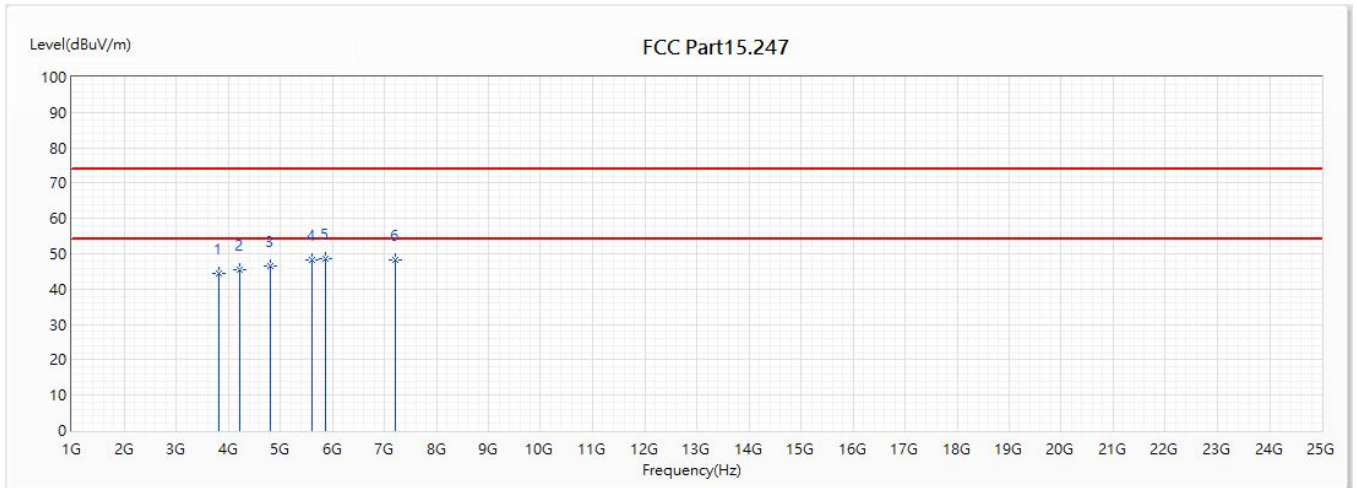

No	Frequency (MHz)	Emission Level (dBuV/m)	Limit (dBuV/m)	Margin (dB)	Reading Level (dBuV)	Correct Factor (dB)	Detector Type
1	3824	44.48	74.00	-29.52	40.44	4.04	PK
2	4232	45.61	74.00	-28.39	40.08	5.53	PK
3	4804	46.49	74.00	-27.51	39.30	7.19	PK
4	5616	48.11	74.00	-25.89	39.27	8.84	PK
* 5	5862	48.65	74.00	-25.35	39.08	9.57	PK
6	7206	48.37	74.00	-25.63	33.03	15.34	PK

Note:

1. All reading above 1GHz is performed with peak and/or average measurements as necessary.
2. “ * ”, means this data is the worst emission level.
3. Emission Level = Reading Level + Correct Factor.
4. The average measurement was not performed when the peak measured data under the limit of average detection.
5. The Emission above 13GHz were not included is because their levels are too low.

Site :	CB4-H	Engineer :	Lion
Model No :	MEGA XL GPS	Test Date :	2018/11/30
Test Voltage :	AC 120V/60Hz	Polarity :	Horizontal
Test Mode :	Mode 1: Transmit Power by PC		
Note :	802.15.1_BLE_2440MHz		

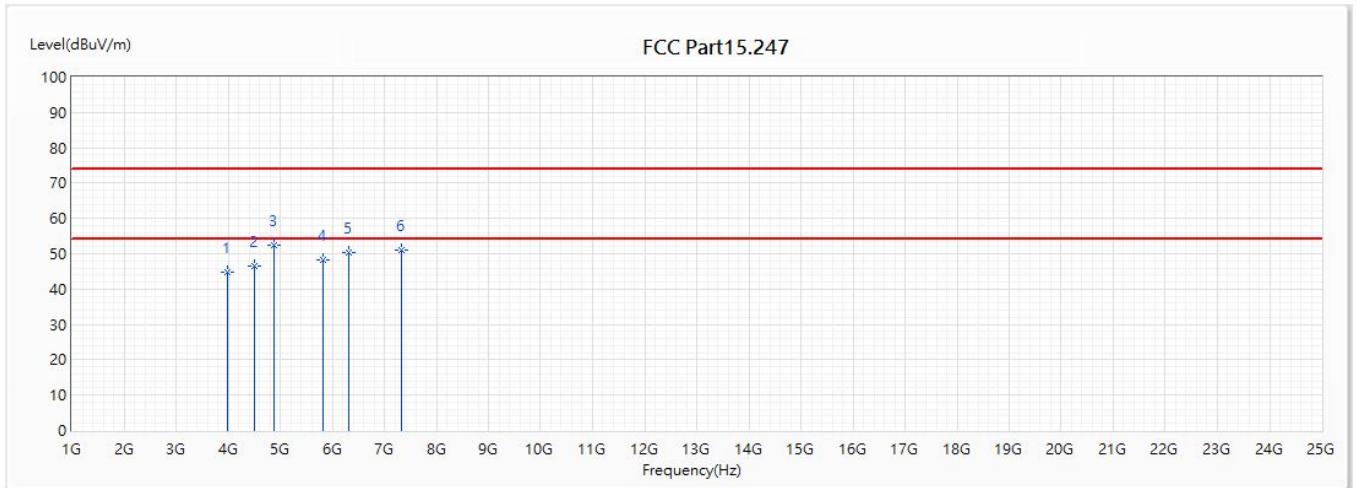

No	Frequency (MHz)	Emission Level (dBuV/m)	Limit (dBuV/m)	Margin (dB)	Reading Level (dBuV)	Correct Factor (dB)	Detector Type
1	3984	44.68	74.00	-29.32	39.85	4.83	PK
2	4500	46.52	74.00	-27.48	40.18	6.34	PK
* 3	4880	52.47	74.00	-21.53	44.85	7.62	PK
4	5826	48.19	74.00	-25.81	38.72	9.47	PK
5	6312	50.21	74.00	-23.79	38.33	11.88	PK
6	7320	51.15	74.00	-22.85	35.41	15.74	PK

Note:

1. All reading above 1GHz is performed with peak and/or average measurements as necessary.
2. “ * ”, means this data is the worst emission level.
3. Emission Level = Reading Level + Correct Factor.
4. The average measurement was not performed when the peak measured data under the limit of average detection.
5. The Emission above 13GHz were not included is because their levels are too low.

Site :	CB4-H	Engineer :	Lion
Model No :	MEGA XL GPS	Test Date :	2018/11/30
Test Voltage :	AC 120V/60Hz	Polarity :	Vertical
Test Mode :	Mode 1: Transmit Power by PC		
Note :	802.15.1_BLE_2440MHz		

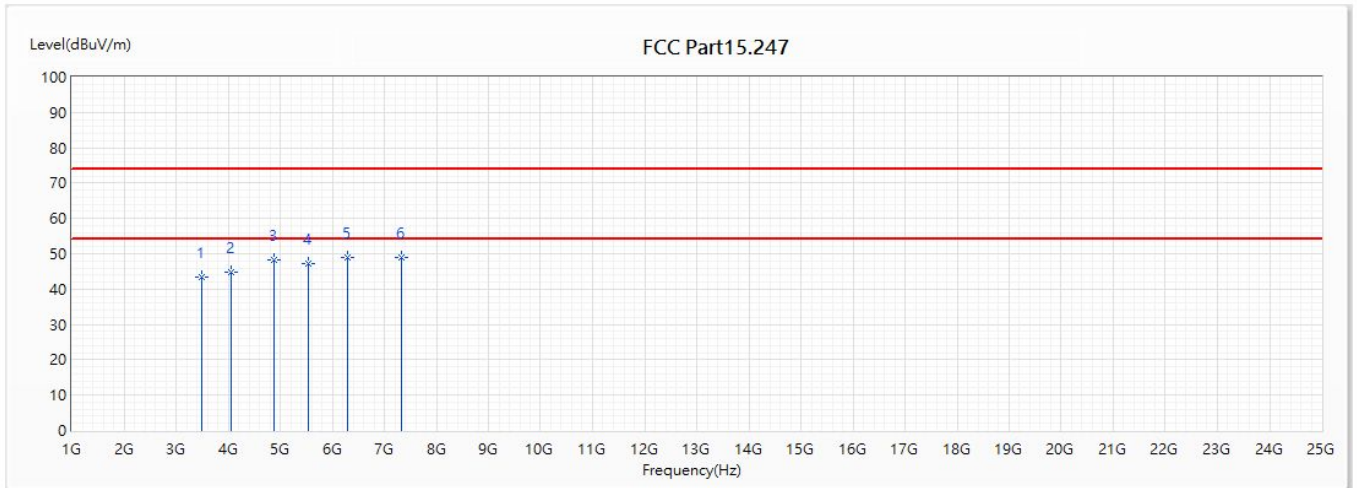

No	Frequency (MHz)	Emission Level (dBuV/m)	Limit (dBuV/m)	Margin (dB)	Reading Level (dBuV)	Correct Factor (dB)	Detector Type
1	3498	43.27	74.00	-30.73	40.91	2.36	PK
2	4054	44.78	74.00	-29.22	39.53	5.25	PK
3	4880	48.19	74.00	-25.81	40.57	7.62	PK
4	5534	47.37	74.00	-26.63	38.67	8.70	PK
* 5	6290	49.13	74.00	-24.87	37.72	11.41	PK
6	7320	48.97	74.00	-25.03	33.23	15.74	PK

Note:

1. All reading above 1GHz is performed with peak and/or average measurements as necessary.
2. “ * ”, means this data is the worst emission level.
3. Emission Level = Reading Level + Correct Factor.
4. The average measurement was not performed when the peak measured data under the limit of average detection.
5. The Emission above 13GHz were not included is because their levels are too low.

Site :	CB4-H	Engineer :	Lion
Model No :	MEGA XL GPS	Test Date :	2018/11/30
Test Voltage :	AC 120V/60Hz	Polarity :	Horizontal
Test Mode :	Mode 1: Transmit Power by PC		
Note :	802.15.1_BLE_2480MHz		

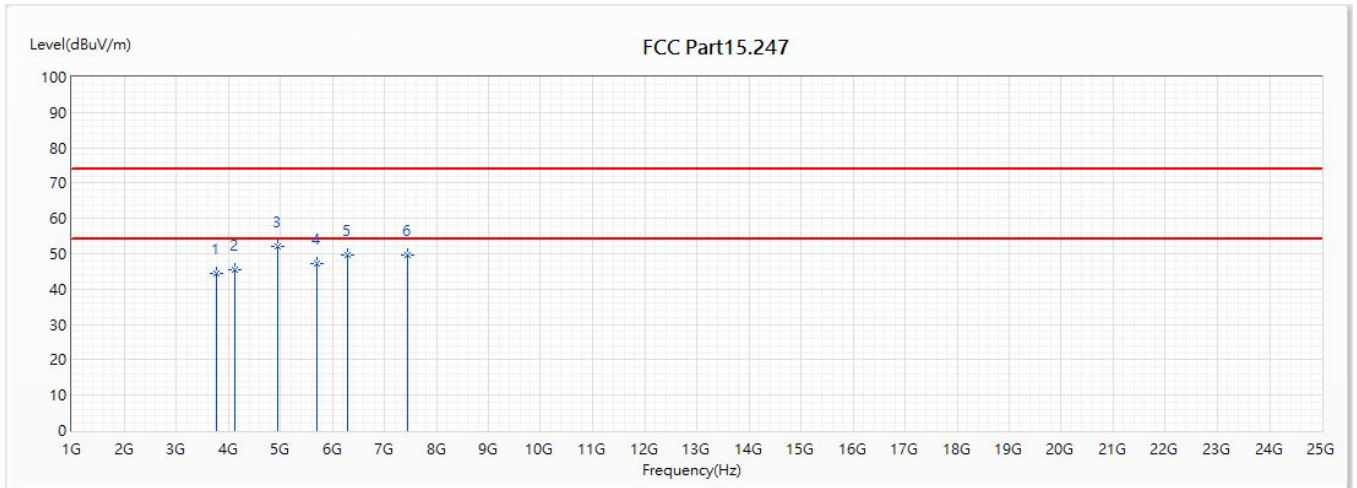

No	Frequency (MHz)	Emission Level (dBuV/m)	Limit (dBuV/m)	Margin (dB)	Reading Level (dBuV)	Correct Factor (dB)	Detector Type
1	3780	44.38	74.00	-29.62	40.58	3.80	PK
2	4122	45.63	74.00	-28.37	40.27	5.36	PK
* 3	4960	52.03	74.00	-21.97	43.90	8.13	PK
4	5698	47.25	74.00	-26.75	38.16	9.09	PK
5	6296	49.76	74.00	-24.24	37.92	11.84	PK
6	7440	49.79	74.00	-24.21	33.41	16.38	PK

Note:

1. All reading above 1GHz is performed with peak and/or average measurements as necessary.
2. “ * ”, means this data is the worst emission level.
3. Emission Level = Reading Level + Correct Factor.
4. The average measurement was not performed when the peak measured data under the limit of average detection.
5. The Emission above 13GHz were not included is because their levels are too low.

Site :	CB4-H	Engineer :	Lion
Model No :	MEGA XL GPS	Test Date :	2018/11/30
Test Voltage :	AC 120V/60Hz	Polarity :	Vertical
Test Mode :	Mode 1: Transmit Power by PC		
Note :	802.15.1_BLE_2480MHz		

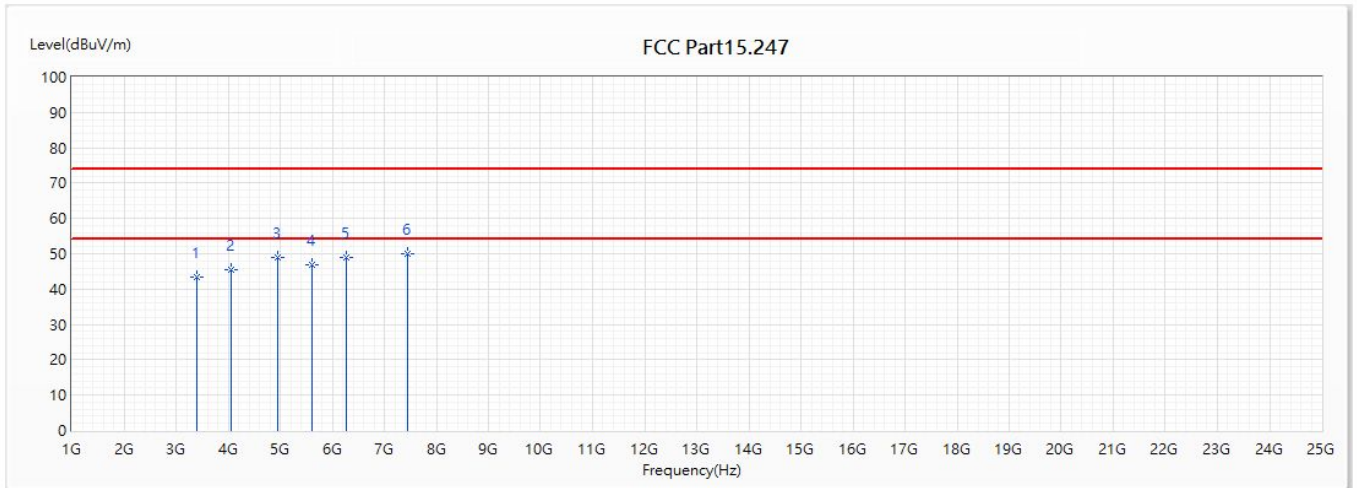

No	Frequency (MHz)	Emission Level (dBuV/m)	Limit (dBuV/m)	Margin (dB)	Reading Level (dBuV)	Correct Factor (dB)	Detector Type
1	3396	43.25	74.00	-30.75	41.06	2.19	PK
2	4060	45.64	74.00	-28.36	40.36	5.28	PK
3	4960	49.05	74.00	-24.95	40.91	8.14	PK
4	5618	46.96	74.00	-27.04	38.11	8.85	PK
5	6262	48.99	74.00	-25.01	37.65	11.34	PK
* 6	7440	50.07	74.00	-23.93	33.69	16.38	PK

Note:

1. All reading above 1GHz is performed with peak and/or average measurements as necessary.
2. “ * ”, means this data is the worst emission level.
3. Emission Level = Reading Level + Correct Factor.
4. The average measurement was not performed when the peak measured data under the limit of average detection.
5. The Emission above 13GHz were not included is because their levels are too low.

5. RF antenna conducted test

5.1. Test Setup

RF Conducted Measurement:

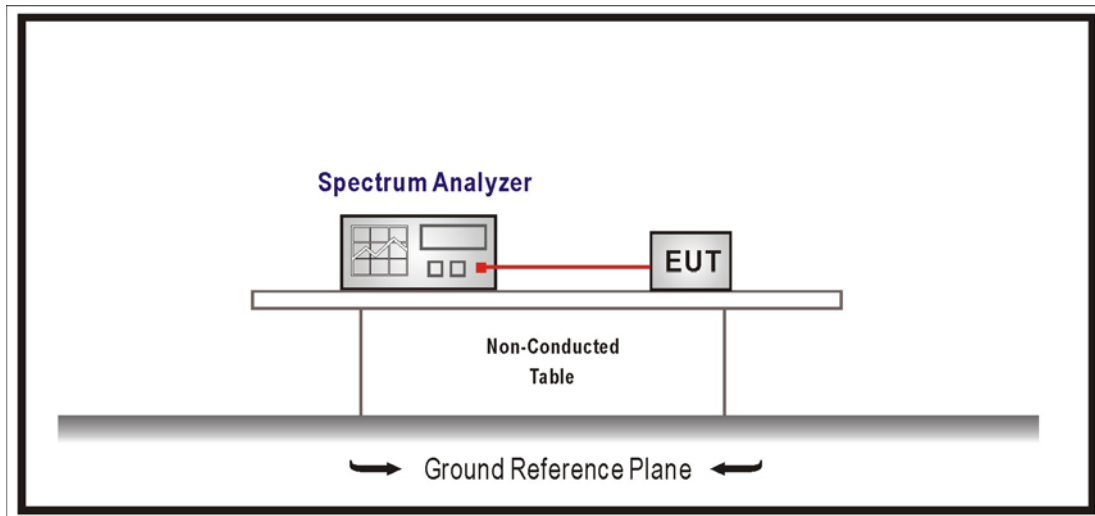

5.2. Limits

In any 100 kHz bandwidth outside the frequency band in which the spread spectrum or digitally modulated intentional radiator is operating, the radio frequency power that is produced by the intentional radiator shall be at least 20 dB below that in the 100 kHz bandwidth within the band that contains the highest level of the desired power, based on either an RF conducted or a radiated measurement, provided the transmitter demonstrates compliance with the peak conducted power limits. If the transmitter complies with the conducted power limits based on the use of RMS averaging over a time interval, the attenuation required under this paragraph shall be 30 dB instead of 20 dB. Attenuation below the general limits specified in §15.209(a) is not required. In addition, radiated emissions which fall in the restricted bands, as defined in §15.205(a), must also comply with the radiated emission limits specified in §15.209(a) (see §15.205(c)).

5.3. Test Procedure

The EUT was setup according to ANSI C63.10: 2013 and tested according to DTS test procedure of KDB558074 V05 for compliance to FCC 47CFR 15.247 requirements. Set RBW = 100 kHz, Set VBW > RBW, scan up through 10th harmonic.

5.4. Test Specification

According to FCC Part 15 Subpart C Paragraph 15.247 and ISSED RSS-247.

5.5. Test Result

Product	Cycling computer		
Test Item	RF antenna conducted test		
Test Mode	Mode 1: Transmit_Power by PC		
Date of Test	2018/12/04	Test Site	SR10-H

Channel	Frequency (MHz)	Measure Level (dBc)	Limit (dBc)
0	2402	48.610	≥ 20
19	2440	50.460	≥ 20
39	2480	49.180	≥ 20

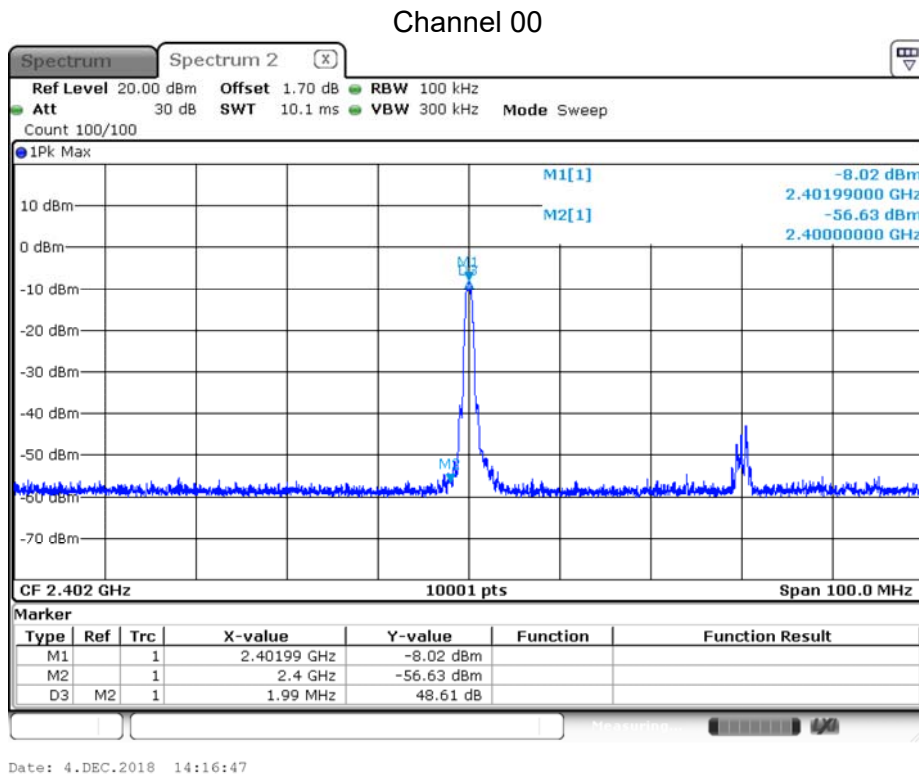

Channel 19

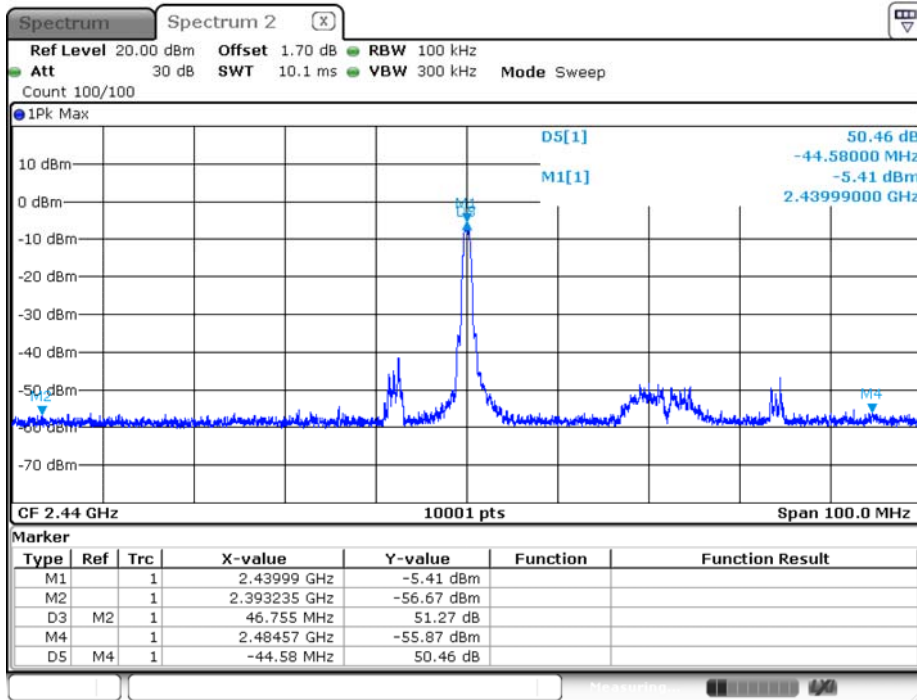

Date: 4.DEC.2018 14:31:11

Channel 39

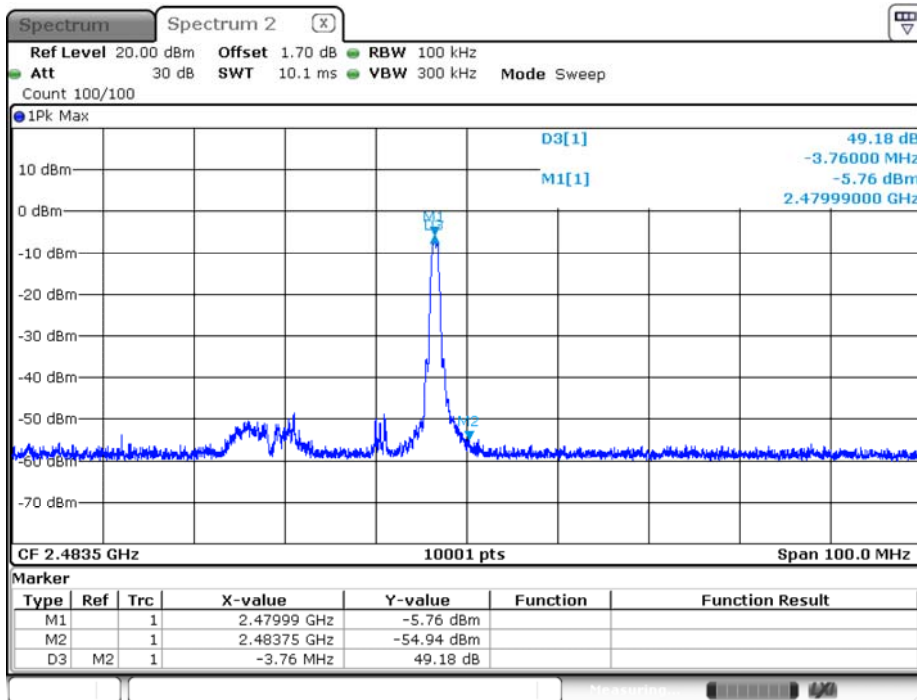

Date: 4.DEC.2018 14:25:45

Product	Cycling computer		
Test Item	RF antenna conducted test		
Test Mode	Mode 1: Transmit_Power by PC		
Date of Test	2018/12/04	Test Site	SR10-H

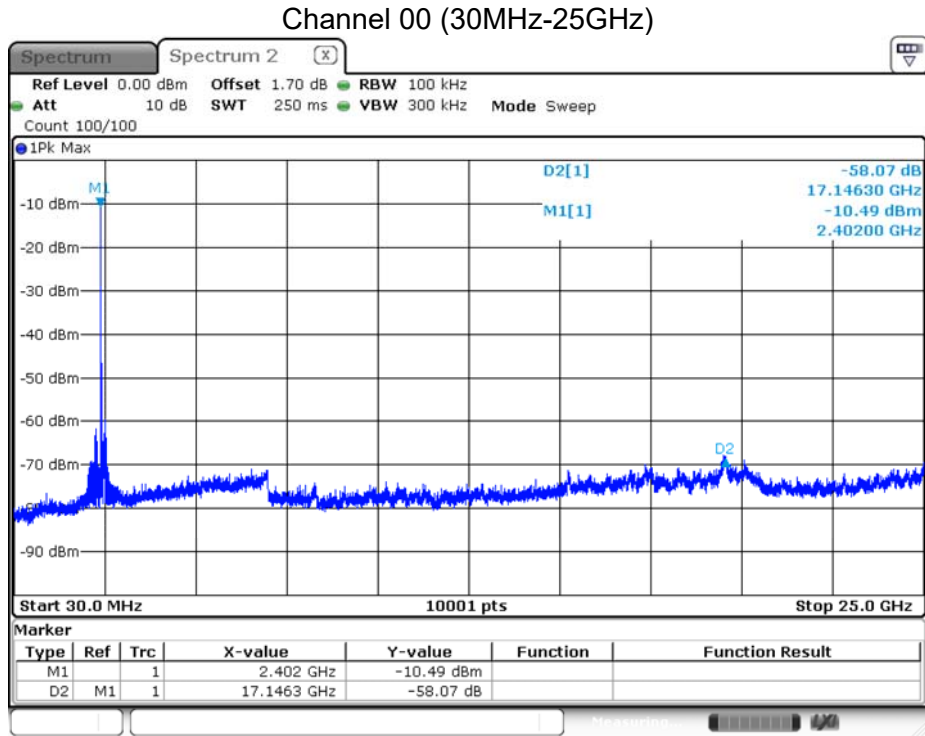

Date: 4.DEC.2018 13:57:31

Channel 19 (30MHz-25GHz)

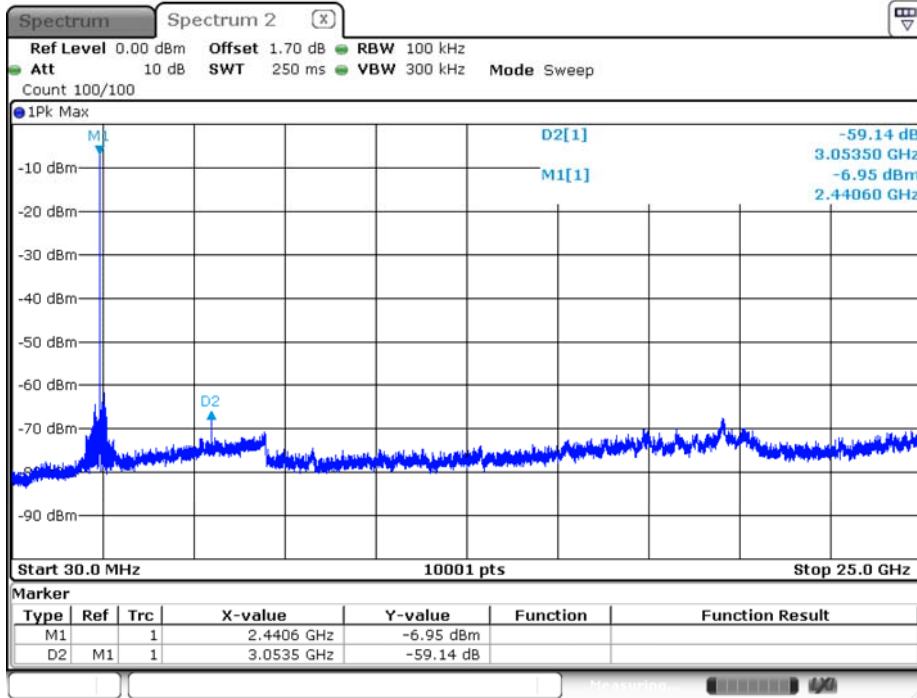

Date: 4.DEC.2018 13:51:58

Channel 39 (30MHz-25GHz)

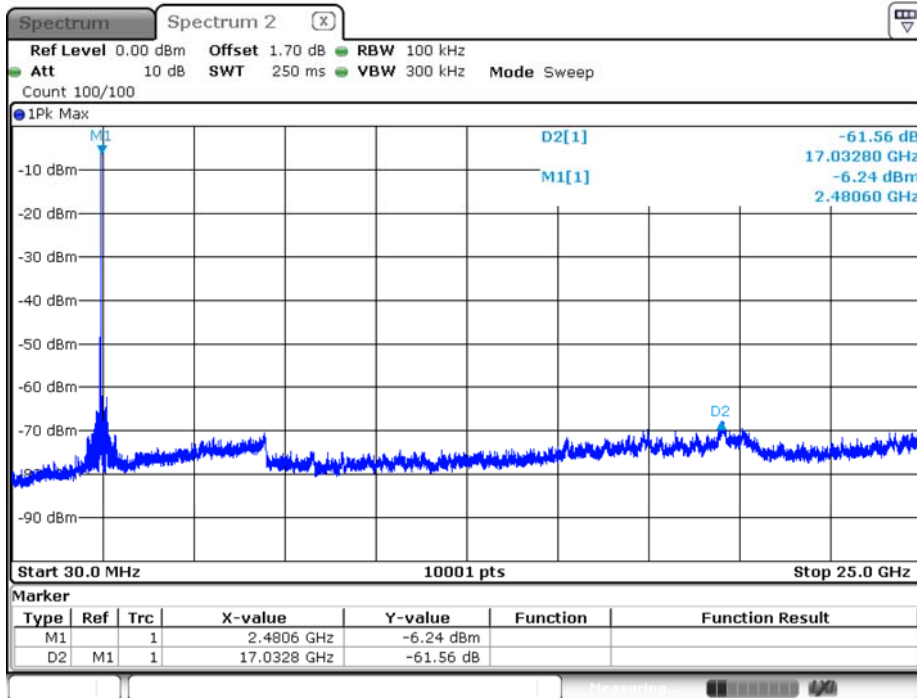

Date: 4.DEC.2018 13:48:46

6. Radiated Emission Band Edge

6.1. Test Setup

RF Radiated Measurement:

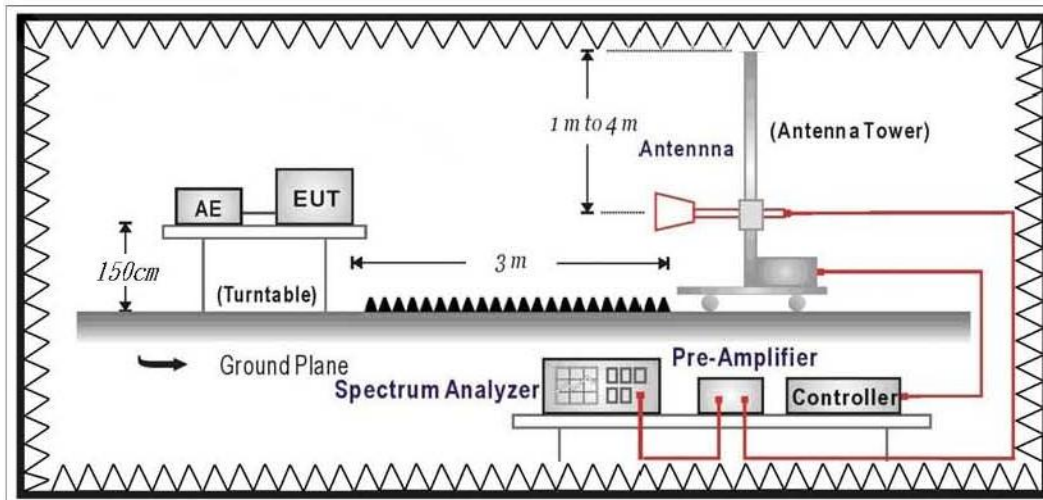

6.2. Limits

Emissions radiated outside of the specified frequency bands, except for harmonics, shall be attenuated by at least 20dB below the level of the fundamental or to the general radiated emission limits in paragraph 15.209, whichever is the lesser attenuation.

6.3. Test Procedure

The EUT was setup according to ANSI C63.10: 2013 and tested according to DTS test procedure of KDB558074 V05 for compliance to FCC 47CFR 15.247 requirements. The EUT and its simulators are placed on a turn table which is 1.5 meter above ground. The turn table can rotate 360 degrees to determine the position of the maximum emission level. The EUT was positioned such that the distance from antenna to the EUT was 3 meters.

The antenna can move up and down between 1 meter and 4 meters to find out the maximum emission level.

Both horizontal and vertical polarization of the antenna are set on measurement. In order to find the maximum emission, all of the interface cables must be manipulated according to ANSI C63.10: 2013 on radiated measurement.

6.4. Test Specification

According to FCC Part 15 Subpart C Paragraph 15.247 and ISED RSS-247.

6.5. Test Result

Site :	CB4-H	Engineer :	Andy Tsai
Model No :	MEGA XL GPS	Test Date :	2018/11/29
Test Voltage :	AC 120V/60Hz	Polarity :	Horizontal
Test Mode :	Mode 1: Transmit Power by PC		
Note :	802.15.1_BLE_2402MHz		

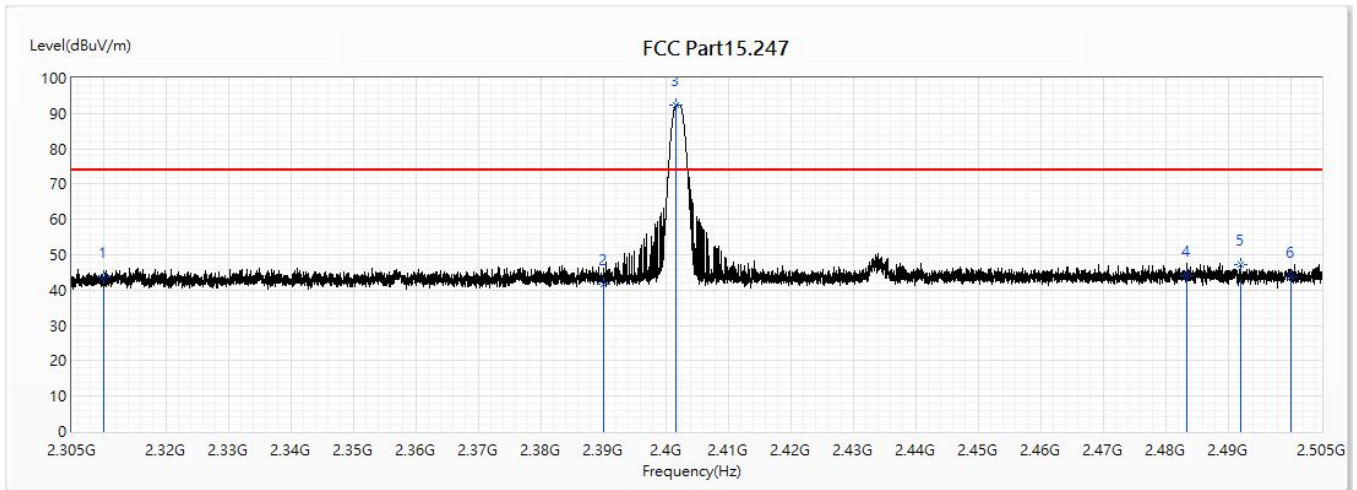

No	Frequency (MHz)	Emission Level (dBuV/m)	Limit (dBuV/m)	Margin (dB)	Reading Level (dBuV)	Correct Factor (dB)	Detector Type
1	2310	43.79	74.00	-30.21	29.56	14.23	PK
2	2390	41.74	74.00	-32.26	27.04	14.70	PK
! 3	2401.74	92.51	74.00	18.51	77.73	14.78	PK
4	2483.5	44.17	74.00	-29.83	28.89	15.28	PK
5	2492.12	47.23	74.00	-26.77	31.90	15.33	PK
6	2500	43.77	74.00	-30.23	28.39	15.38	PK

Note:

1. All reading above 1GHz is performed with peak and/or average measurements as necessary.
2. “ * ”, means this data is the worst emission level.
3. Emission Level = Reading Level + Correct Factor.
4. The average measurement was not performed when the peak measured data under the limit of average detection. If the readings given are average, peak measurement should also be supplied.
5. The fundamental for reference only, it’s not restricted by unwanted emission limit.

Site :	CB4-H	Engineer :	Andy Tsai
Model No :	MEGA XL GPS	Test Date :	2018/11/29
Test Voltage :	AC 120V/60Hz	Polarity :	Horizontal
Test Mode :	Mode 1: Transmit Power by PC		
Note :	802.15.1_BLE_2402MHz		

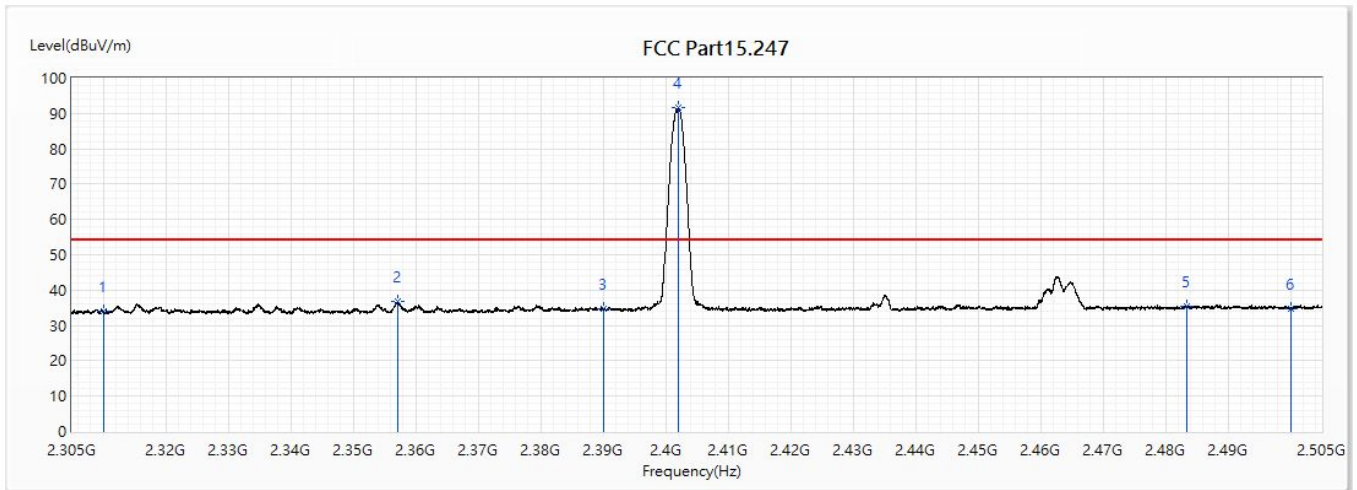

No	Frequency (MHz)	Emission Level (dBuV/m)	Limit (dBuV/m)	Margin (dB)	Reading Level (dBuV)	Correct Factor (dB)	Detector Type
1	2310	34.05	54.00	-19.95	19.82	14.23	AV
2	2357.08	36.80	54.00	-17.20	22.29	14.51	AV
3	2390	34.57	54.00	-19.43	19.87	14.70	AV
! 4	2402.08	91.52	54.00	37.52	76.74	14.78	AV
5	2483.5	35.33	54.00	-18.67	20.05	15.28	AV
6	2500	34.71	54.00	-19.29	19.33	15.38	AV

Note:

1. All reading above 1GHz is performed with peak and/or average measurements as necessary.
2. “ * ”, means this data is the worst emission level.
3. Emission Level = Reading Level + Correct Factor.
4. The average measurement was not performed when the peak measured data under the limit of average detection. If the readings given are average, peak measurement should also be supplied.
5. The fundamental for reference only, it's not restricted by unwanted emission limit.

Site :	CB4-H	Engineer :	Andy Tsai
Model No :	MEGA XL GPS	Test Date :	2018/11/29
Test Voltage :	AC 120V/60Hz	Polarity :	Vertical
Test Mode :	Mode 1: Transmit Power by PC		
Note :	802.15.1_BLE_2402MHz		

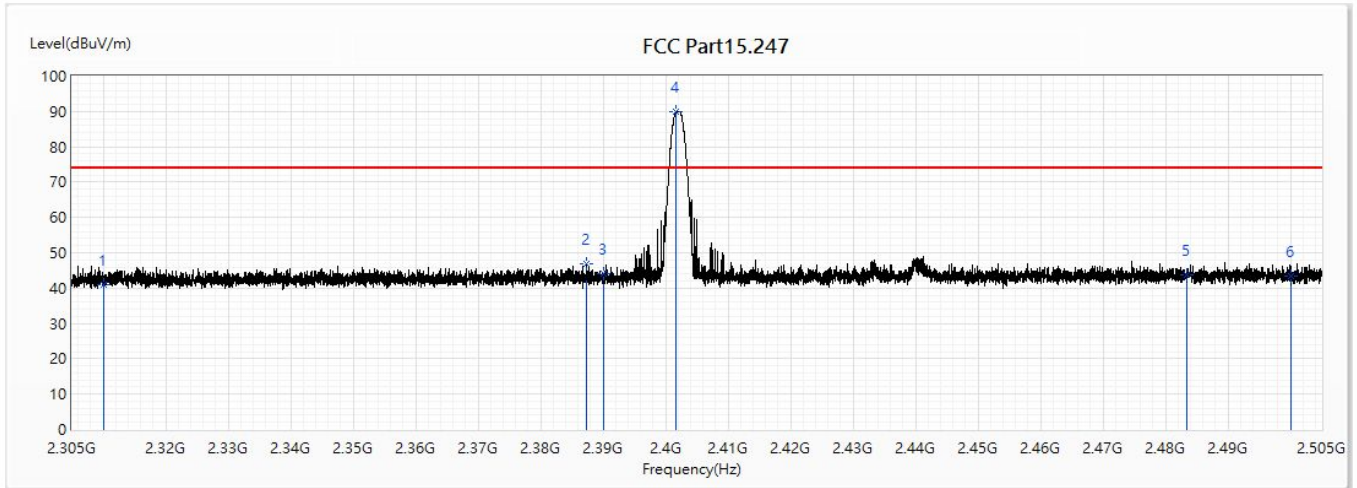

No	Frequency (MHz)	Emission Level (dBuV/m)	Limit (dBuV/m)	Margin (dB)	Reading Level (dBuV)	Correct Factor (dB)	Detector Type
1	2310	40.87	74.00	-33.13	26.64	14.23	PK
2	2387.4	46.98	74.00	-27.02	32.29	14.69	PK
3	2390	44.08	74.00	-29.92	29.38	14.70	PK
! 4	2401.76	89.94	74.00	15.94	75.16	14.78	PK
5	2483.5	43.80	74.00	-30.20	28.52	15.28	PK
6	2500	43.27	74.00	-30.73	27.89	15.38	PK

Note:

1. All reading above 1GHz is performed with peak and/or average measurements as necessary.
2. “ * ”, means this data is the worst emission level.
3. Emission Level = Reading Level + Correct Factor.
4. The average measurement was not performed when the peak measured data under the limit of average detection. If the readings given are average, peak measurement should also be supplied.
5. The fundamental for reference only, it's not restricted by unwanted emission limit.

Site :	CB4-H	Engineer :	Andy Tsai
Model No :	MEGA XL GPS	Test Date :	2018/11/29
Test Voltage :	AC 120V/60Hz	Polarity :	Vertical
Test Mode :	Mode 1: Transmit Power by PC		
Note :	802.15.1_BLE_2402MHz		

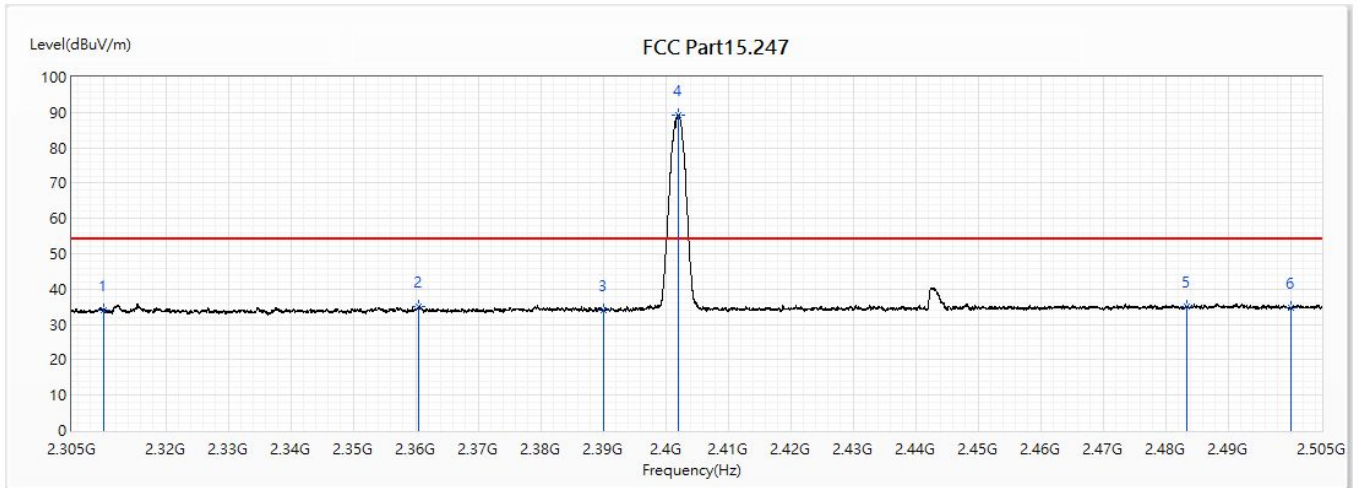

No	Frequency (MHz)	Emission Level (dBuV/m)	Limit (dBuV/m)	Margin (dB)	Reading Level (dBuV)	Correct Factor (dB)	Detector Type
1	2310	33.96	54.00	-20.04	19.73	14.23	AV
2	2360.48	35.10	54.00	-18.90	20.59	14.51	AV
3	2390	34.13	54.00	-19.87	19.43	14.70	AV
! 4	2402.08	89.27	54.00	35.27	74.49	14.78	AV
5	2483.5	34.95	54.00	-19.05	19.67	15.28	AV
6	2500	34.68	54.00	-19.32	19.30	15.38	AV

Note:

1. All reading above 1GHz is performed with peak and/or average measurements as necessary.
2. “ * ”, means this data is the worst emission level.
3. Emission Level = Reading Level + Correct Factor.
4. The average measurement was not performed when the peak measured data under the limit of average detection. If the readings given are average, peak measurement should also be supplied.
5. The fundamental for reference only, it's not restricted by unwanted emission limit.

Site :	CB4-H	Engineer :	Andy Tsai
Model No :	MEGA XL GPS	Test Date :	2018/11/29
Test Voltage :	AC 120V/60Hz	Polarity :	Horizontal
Test Mode :	Mode 1: Transmit Power by PC		
Note :	802.15.1_BLE_2440MHz		

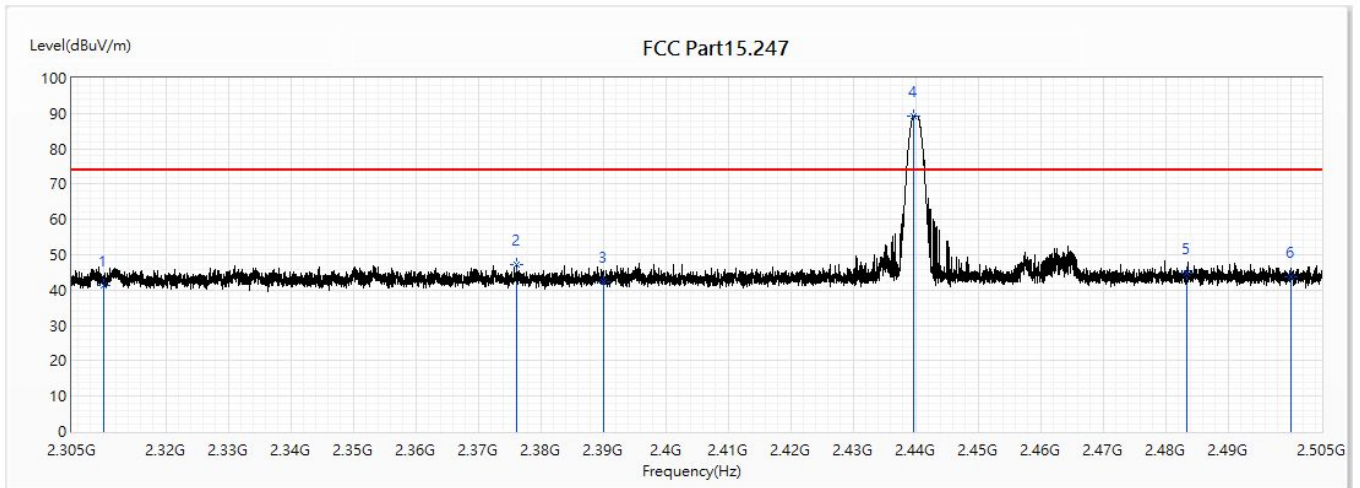

No	Frequency (MHz)	Emission Level (dBuV/m)	Limit (dBuV/m)	Margin (dB)	Reading Level (dBuV)	Correct Factor (dB)	Detector Type
1	2310	41.27	74.00	-32.73	27.04	14.23	PK
2	2376.18	47.36	74.00	-26.64	32.75	14.61	PK
3	2390	42.19	74.00	-31.81	27.49	14.70	PK
! 4	2439.74	89.36	74.00	15.36	74.35	15.01	PK
5	2483.5	44.84	74.00	-29.16	29.56	15.28	PK
6	2500	43.89	74.00	-30.11	28.51	15.38	PK

Note:

1. All reading above 1GHz is performed with peak and/or average measurements as necessary.
2. “ * ”, means this data is the worst emission level.
3. Emission Level = Reading Level + Correct Factor.
4. The average measurement was not performed when the peak measured data under the limit of average detection. If the readings given are average, peak measurement should also be supplied.
5. The fundamental for reference only, it's not restricted by unwanted emission limit.

Site :	CB4-H	Engineer :	Andy Tsai
Model No :	MEGA XL GPS	Test Date :	2018/11/29
Test Voltage :	AC 120V/60Hz	Polarity :	Horizontal
Test Mode :	Mode 1: Transmit Power by PC		
Note :	802.15.1_BLE_2440MHz		

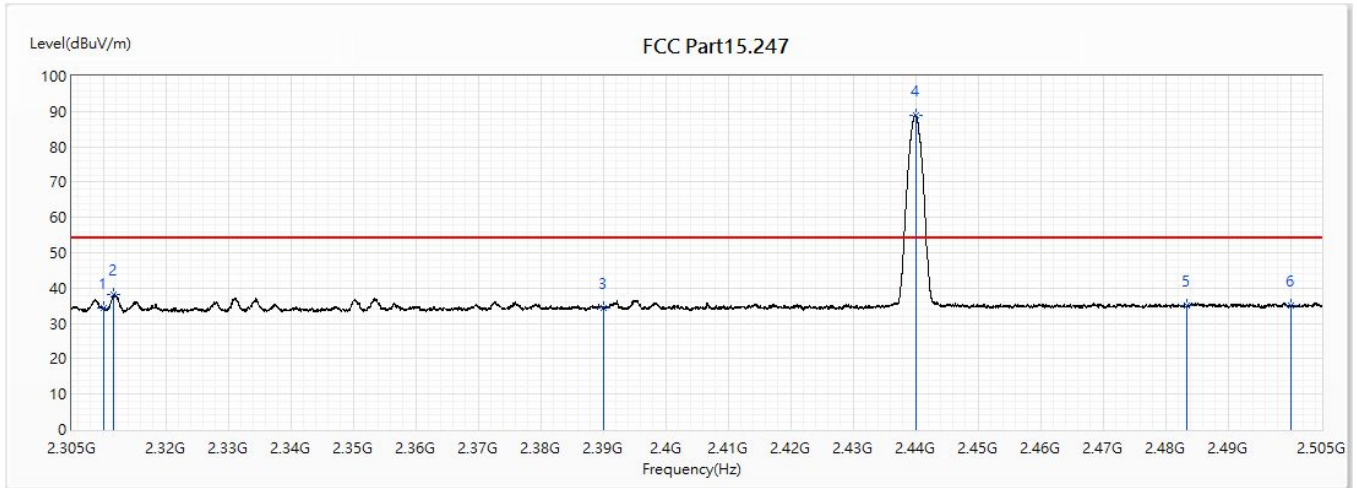

No	Frequency (MHz)	Emission Level (dBuV/m)	Limit (dBuV/m)	Margin (dB)	Reading Level (dBuV)	Correct Factor (dB)	Detector Type
1	2310	34.28	54.00	-19.72	20.05	14.23	AV
2	2311.72	38.15	54.00	-15.85	23.89	14.26	AV
3	2390	34.54	54.00	-19.46	19.84	14.70	AV
! 4	2440.02	88.88	54.00	34.88	73.87	15.01	AV
5	2483.5	35.05	54.00	-18.95	19.77	15.28	AV
6	2500	35.02	54.00	-18.98	19.64	15.38	AV

Note:

1. All reading above 1GHz is performed with peak and/or average measurements as necessary.
2. “ * ”, means this data is the worst emission level.
3. Emission Level = Reading Level + Correct Factor.
4. The average measurement was not performed when the peak measured data under the limit of average detection. If the readings given are average, peak measurement should also be supplied.
5. The fundamental for reference only, it's not restricted by unwanted emission limit.

Site :	CB4-H	Engineer :	Andy Tsai
Model No :	MEGA XL GPS	Test Date :	2018/11/29
Test Voltage :	AC 120V/60Hz	Polarity :	Vertical
Test Mode :	Mode 1: Transmit Power by PC		
Note :	802.15.1_BLE_2440MHz		

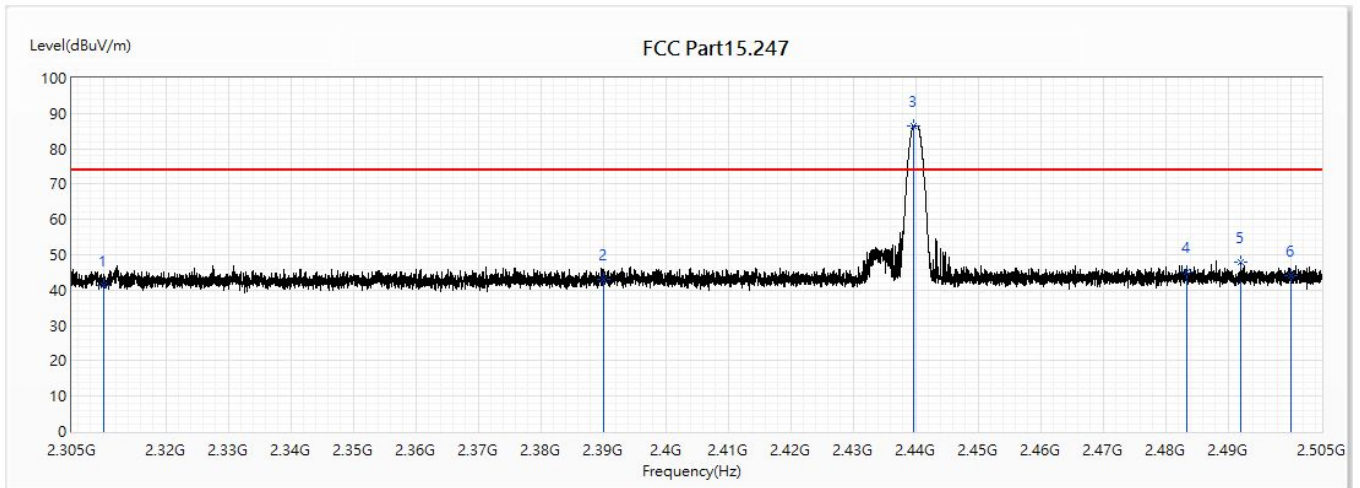

No	Frequency (MHz)	Emission Level (dBuV/m)	Limit (dBuV/m)	Margin (dB)	Reading Level (dBuV)	Correct Factor (dB)	Detector Type
1	2310	41.24	74.00	-32.76	27.01	14.23	PK
2	2390	42.95	74.00	-31.05	28.25	14.70	PK
! 3	2439.72	86.59	74.00	12.59	71.58	15.01	PK
4	2483.5	45.03	74.00	-28.97	29.75	15.28	PK
5	2492.08	48.06	74.00	-25.94	32.73	15.33	PK
6	2500	44.11	74.00	-29.89	28.73	15.38	PK

Note:

1. All reading above 1GHz is performed with peak and/or average measurements as necessary.
2. “ * ”, means this data is the worst emission level.
3. Emission Level = Reading Level + Correct Factor.
4. The average measurement was not performed when the peak measured data under the limit of average detection. If the readings given are average, peak measurement should also be supplied.
5. The fundamental for reference only, it's not restricted by unwanted emission limit.

Site :	CB4-H	Engineer :	Andy Tsai
Model No :	MEGA XL GPS	Test Date :	2018/11/29
Test Voltage :	AC 120V/60Hz	Polarity :	Vertical
Test Mode :	Mode 1: Transmit Power by PC		
Note :	802.15.1_BLE_2440MHz		

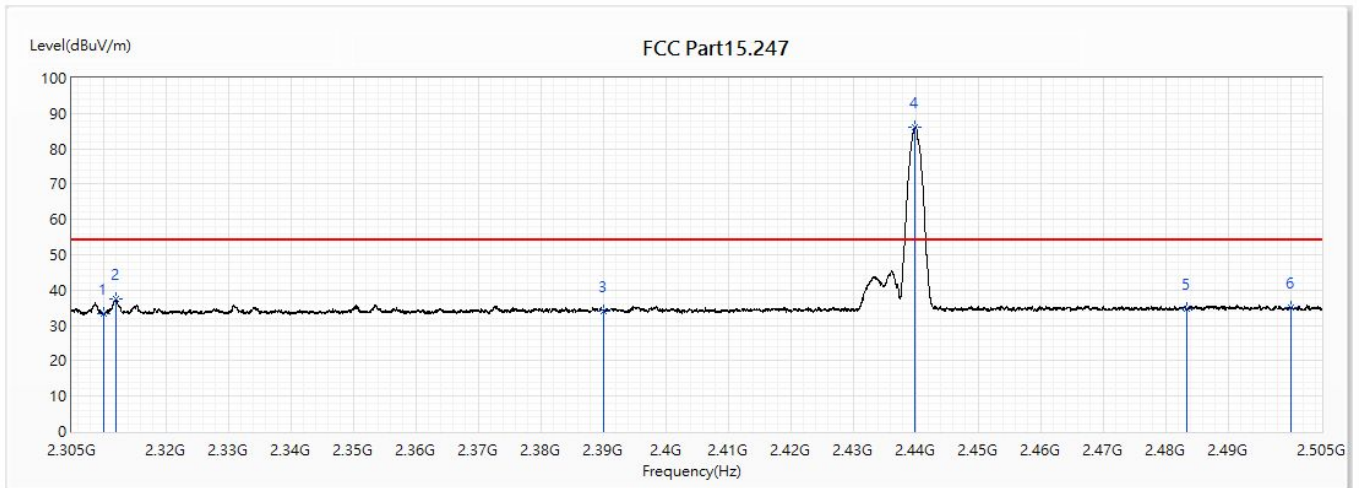

No	Frequency (MHz)	Emission Level (dBuV/m)	Limit (dBuV/m)	Margin (dB)	Reading Level (dBuV)	Correct Factor (dB)	Detector Type
1	2310	33.41	54.00	-20.59	19.18	14.23	AV
2	2312	37.58	54.00	-16.42	23.32	14.26	AV
3	2390	34.14	54.00	-19.86	19.44	14.70	AV
! 4	2439.98	86.07	54.00	32.07	71.06	15.01	AV
5	2483.5	34.63	54.00	-19.37	19.35	15.28	AV
6	2500	34.94	54.00	-19.06	19.56	15.38	AV

Note:

1. All reading above 1GHz is performed with peak and/or average measurements as necessary.
2. “ * ”, means this data is the worst emission level.
3. Emission Level = Reading Level + Correct Factor.
4. The average measurement was not performed when the peak measured data under the limit of average detection. If the readings given are average, peak measurement should also be supplied.
5. The fundamental for reference only, it's not restricted by unwanted emission limit.

Site :	CB4-H	Engineer :	Andy Tsai
Model No :	MEGA XL GPS	Test Date :	2018/11/29
Test Voltage :	AC 120V/60Hz	Polarity :	Horizontal
Test Mode :	Mode 1: Transmit Power by PC		
Note :	802.15.1_BLE_2480MHz		

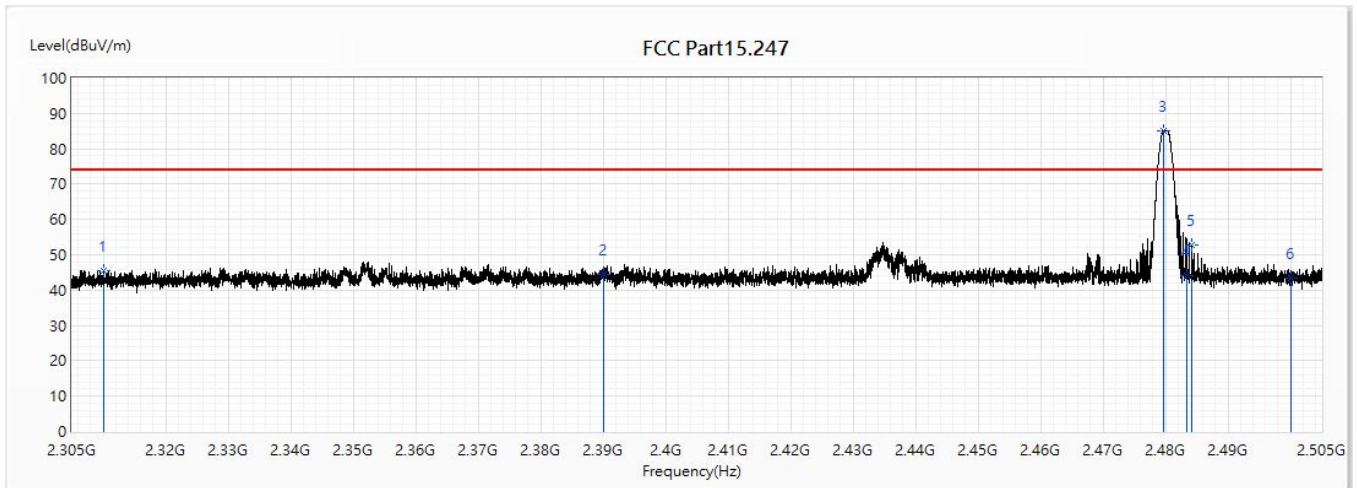

No	Frequency (MHz)	Emission Level (dBuV/m)	Limit (dBuV/m)	Margin (dB)	Reading Level (dBuV)	Correct Factor (dB)	Detector Type
1	2310	45.63	74.00	-28.37	31.40	14.23	PK
2	2390	44.40	74.00	-29.60	29.70	14.70	PK
! 3	2479.76	85.22	74.00	11.22	69.96	15.26	PK
4	2483.5	44.26	74.00	-29.74	28.98	15.28	PK
5	2484.2	52.61	74.00	-21.39	37.33	15.28	PK
6	2500	43.42	74.00	-30.58	28.04	15.38	PK

Note:

1. All reading above 1GHz is performed with peak and/or average measurements as necessary.
2. “ * ”, means this data is the worst emission level.
3. Emission Level = Reading Level + Correct Factor.
4. The average measurement was not performed when the peak measured data under the limit of average detection. If the readings given are average, peak measurement should also be supplied.
5. The fundamental for reference only, it's not restricted by unwanted emission limit.

Site :	CB4-H	Engineer :	Andy Tsai
Model No :	MEGA XL GPS	Test Date :	2018/11/29
Test Voltage :	AC 120V/60Hz	Polarity :	Horizontal
Test Mode :	Mode 1: Transmit Power by PC		
Note :	802.15.1_BLE_2480MHz		

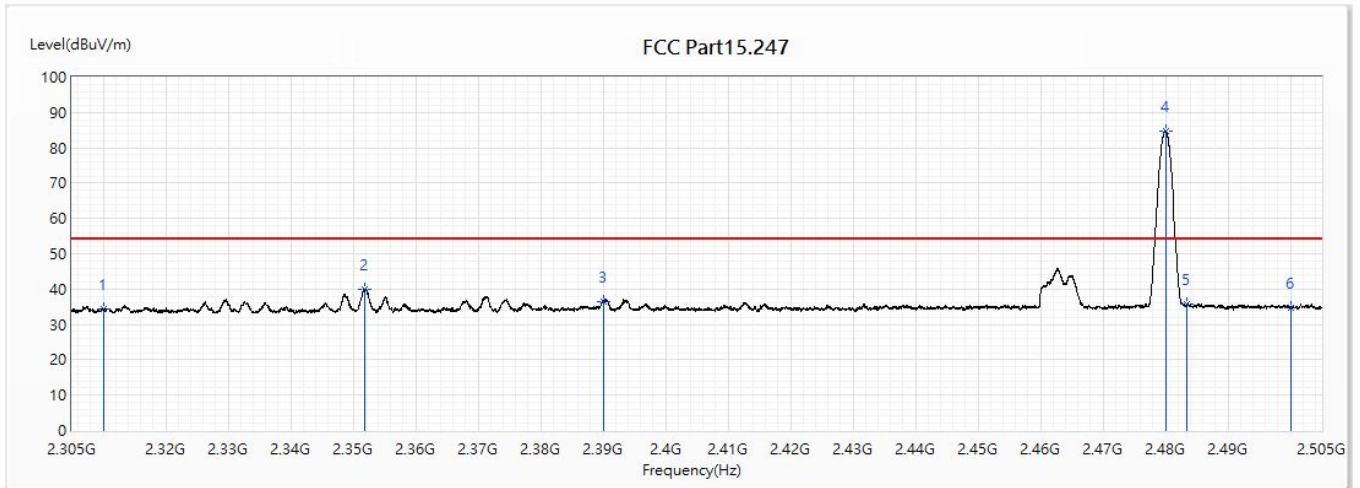

No	Frequency (MHz)	Emission Level (dBuV/m)	Limit (dBuV/m)	Margin (dB)	Reading Level (dBuV)	Correct Factor (dB)	Detector Type
1	2310	34.27	54.00	-19.73	20.04	14.23	AV
2	2351.96	39.95	54.00	-14.05	25.48	14.47	AV
3	2390	36.56	54.00	-17.44	21.86	14.70	AV
! 4	2480.06	84.69	54.00	30.69	69.43	15.26	AV
5	2483.5	35.65	54.00	-18.35	20.37	15.28	AV
6	2500	34.89	54.00	-19.11	19.51	15.38	AV

Note:

1. All reading above 1GHz is performed with peak and/or average measurements as necessary.
2. “ * ”, means this data is the worst emission level.
3. Emission Level = Reading Level + Correct Factor.
4. The average measurement was not performed when the peak measured data under the limit of average detection. If the readings given are average, peak measurement should also be supplied.
5. The fundamental for reference only, it's not restricted by unwanted emission limit.

Site :	CB4-H	Engineer :	Andy Tsai
Model No :	MEGA XL GPS	Test Date :	2018/11/29
Test Voltage :	AC 120V/60Hz	Polarity :	Vertical
Test Mode :	Mode 1: Transmit Power by PC		
Note :	802.15.1_BLE_2480MHz		

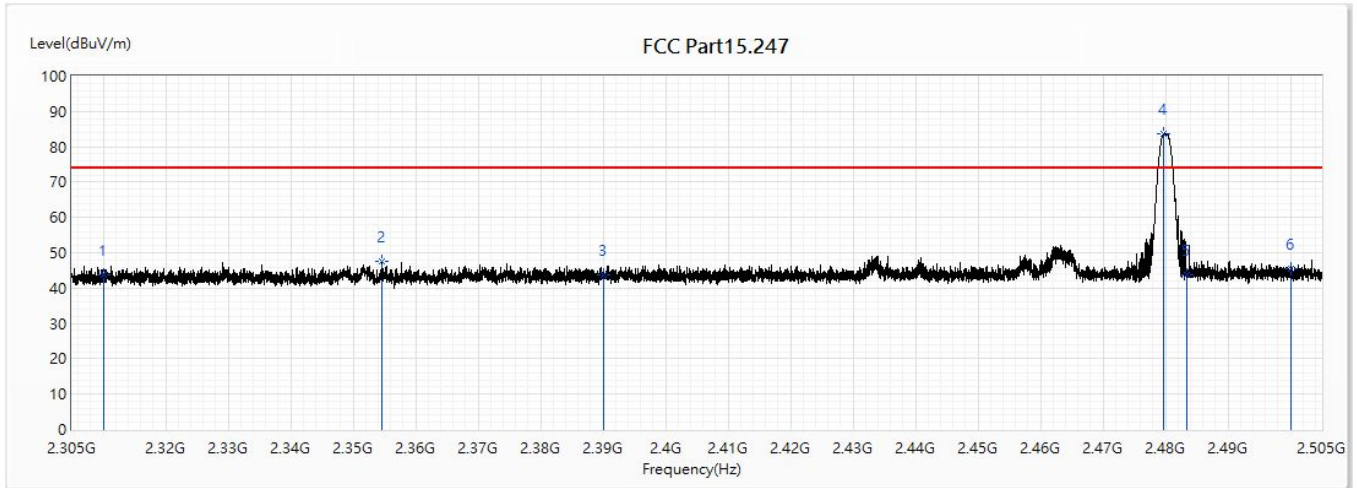

No	Frequency (MHz)	Emission Level (dBuV/m)	Limit (dBuV/m)	Margin (dB)	Reading Level (dBuV)	Correct Factor (dB)	Detector Type
1	2310	43.87	74.00	-30.13	29.64	14.23	PK
2	2354.68	47.54	74.00	-26.46	33.05	14.49	PK
3	2390	43.81	74.00	-30.19	29.11	14.70	PK
! 4	2479.76	83.70	74.00	9.70	68.44	15.26	PK
5	2483.5	43.78	74.00	-30.22	28.50	15.28	PK
6	2500	45.61	74.00	-28.39	30.23	15.38	PK

Note:

1. All reading above 1GHz is performed with peak and/or average measurements as necessary.
2. “ * ”, means this data is the worst emission level.
3. Emission Level = Reading Level + Correct Factor.
4. The average measurement was not performed when the peak measured data under the limit of average detection. If the readings given are average, peak measurement should also be supplied.
5. The fundamental for reference only, it's not restricted by unwanted emission limit.

Site :	CB4-H	Engineer :	Andy Tsai
Model No :	MEGA XL GPS	Test Date :	2018/11/29
Test Voltage :	AC 120V/60Hz	Polarity :	Vertical
Test Mode :	Mode 1: Transmit Power by PC		
Note :	802.15.1_BLE_2480MHz		

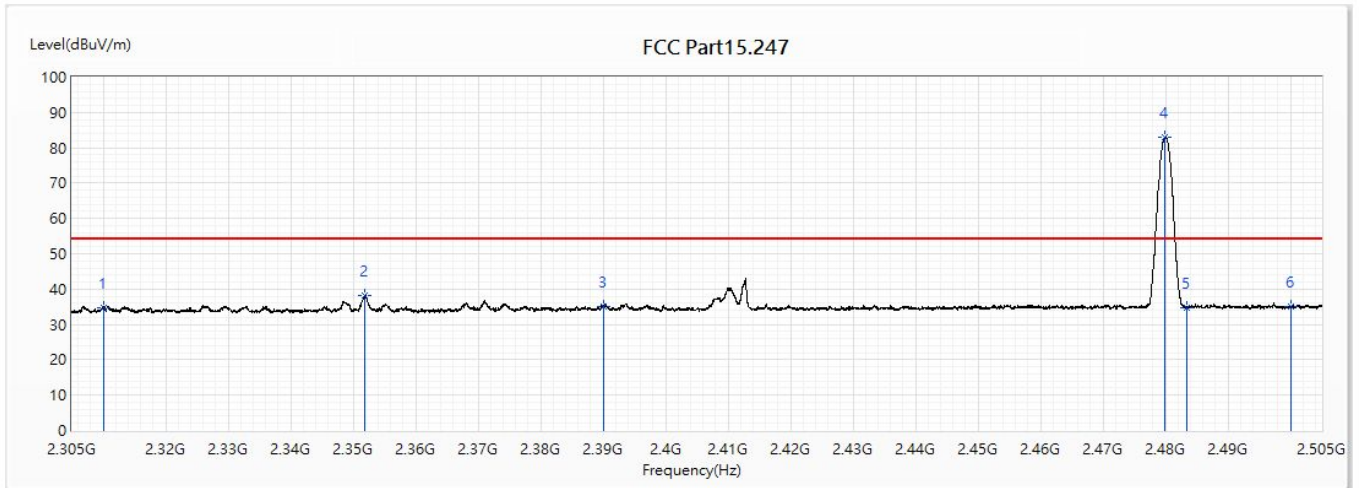

No	Frequency (MHz)	Emission Level (dBuV/m)	Limit (dBuV/m)	Margin (dB)	Reading Level (dBuV)	Correct Factor (dB)	Detector Type
1	2310	34.69	54.00	-19.31	20.46	14.23	AV
2	2351.9	38.16	54.00	-15.84	23.69	14.47	AV
3	2390	35.13	54.00	-18.87	20.43	14.70	AV
! 4	2479.96	83.14	54.00	29.14	67.88	15.26	AV
5	2483.5	34.67	54.00	-19.33	19.39	15.28	AV
6	2500	34.97	54.00	-19.03	19.59	15.38	AV

Note:

1. All reading above 1GHz is performed with peak and/or average measurements as necessary.
2. “ * ”, means this data is the worst emission level.
3. Emission Level = Reading Level + Correct Factor.
4. The average measurement was not performed when the peak measured data under the limit of average detection. If the readings given are average, peak measurement should also be supplied.
5. The fundamental for reference only, it's not restricted by unwanted emission limit.

7. Occupied Bandwidth & DTS Bandwidth

7.1. Test Setup

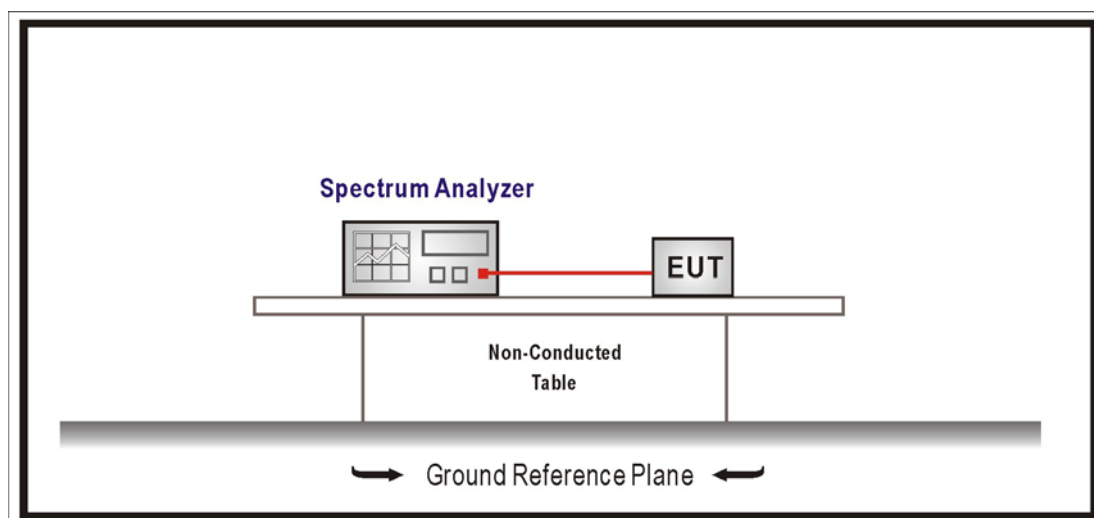

7.2. Limits

The 6 dB bandwidth: ≥ 500 kHz.

Occupied Bandwidth: NA

7.3. Test Procedures

The EUT was setup according to ANSI C63.10: 2013; tested according to DTS test procedure of KDB558074 V05 for compliance to FCC 47CFR 15.247 requirements.

7.4. Test Specification

According to FCC Part 15 Subpart C Paragraph 15.247 and ISSED RSS-247.

7.5. Test Result

Product	Cycling computer		
Test Item	Occupied Bandwidth		
Test Mode	Mode 1: Transmit_Power by PC		
Date of Test	2018/12/04	Test Site	SR10-H

Channel No.	Frequency (MHz)	Measure Level (MHz)	Limit (MHz)
0	2402	1.071	--
19	2440	1.077	--
39	2480	1.079	--

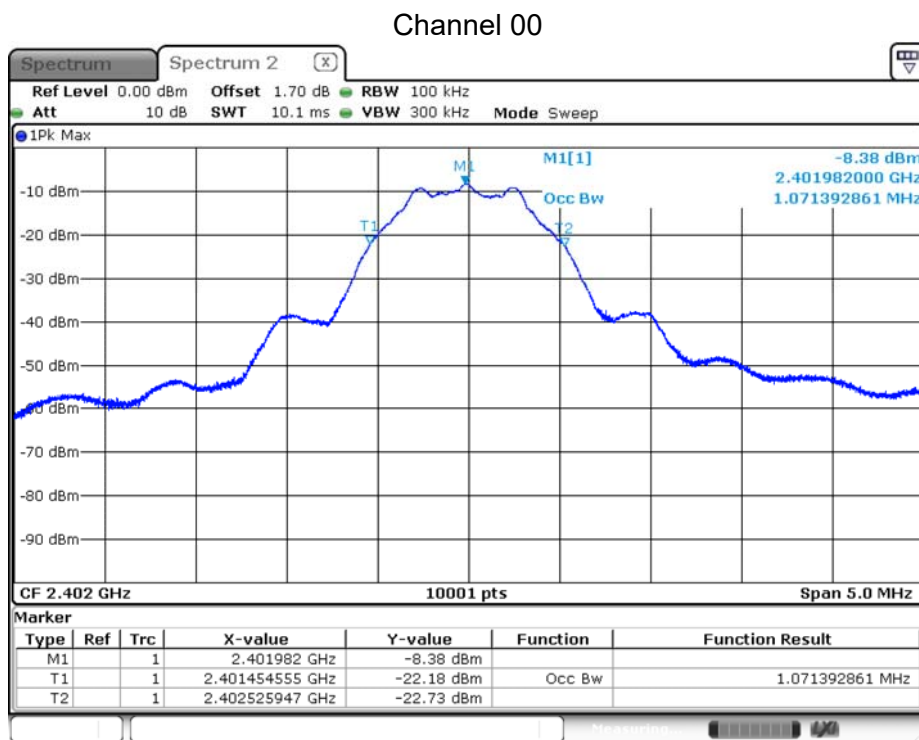

Date: 4.DEC.2018 14:37:26

Channel 19

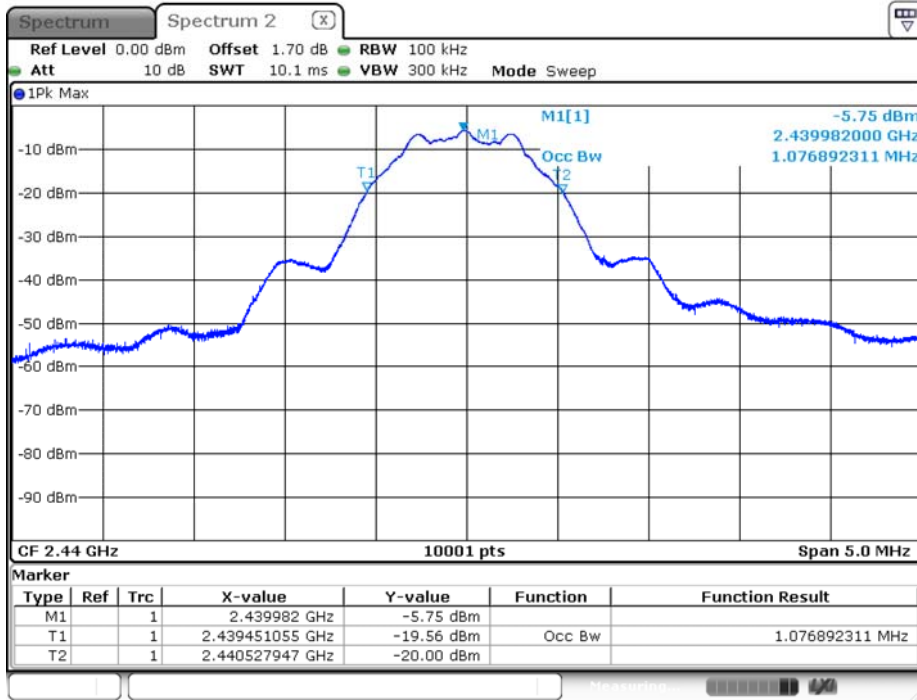

Date: 4.DEC.2018 14:34:50

Channel 39

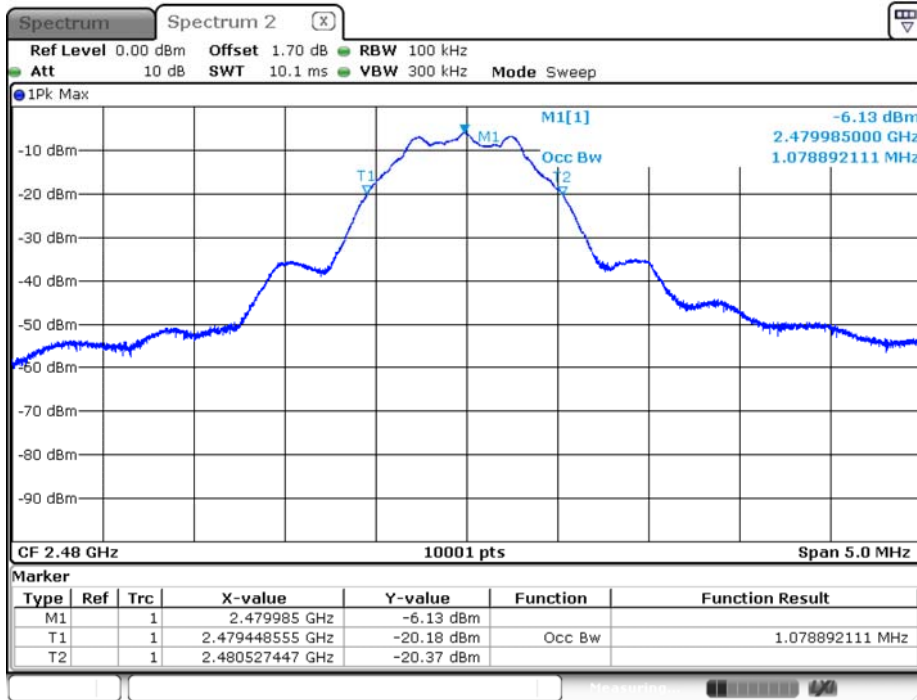

Date: 4.DEC.2018 14:36:28

Product	Cycling computer		
Test Item	DTS Bandwidth		
Test Mode	Mode 1: Transmit_Power by PC		
Date of Test	2018/12/04	Test Site	SR10-H

Channel No.	Frequency (MHz)	Measure Value (MHz)	Limit (MHz)
0	2402	0.685	≥ 0.500
19	2440	0.687	≥ 0.500
39	2480	0.719	≥ 0.500

Channel 00

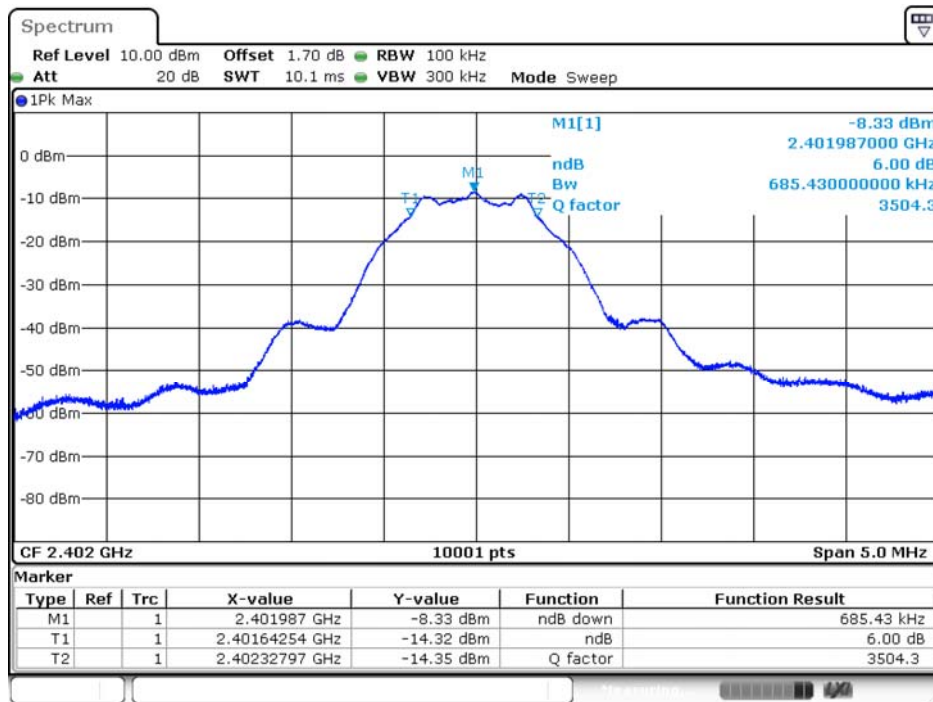

Date: 4.DEC.2018 20:25:01

Channel 19

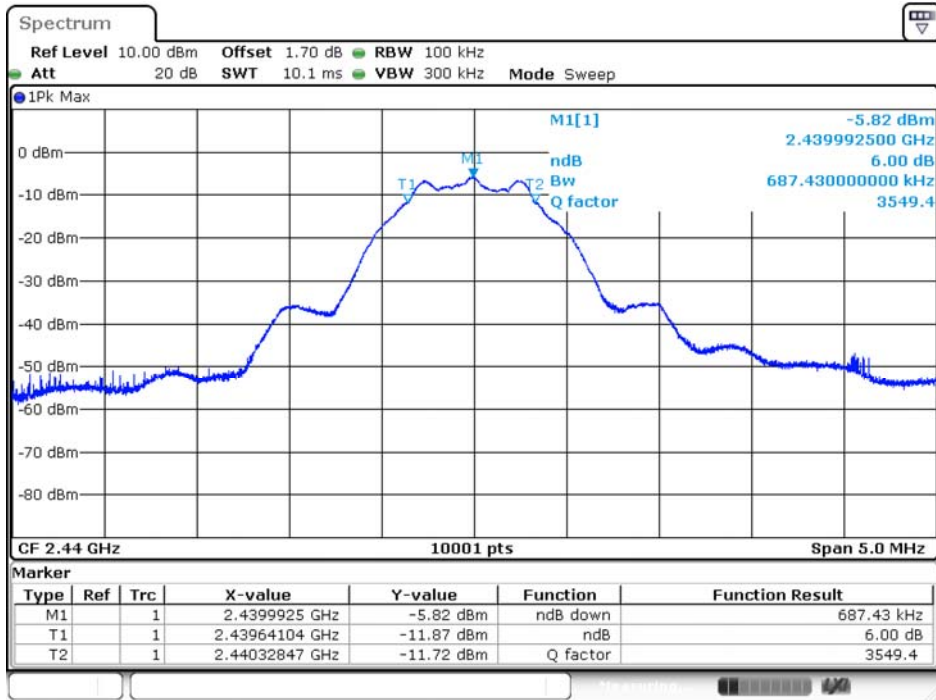

Date: 4.DEC.2018 20:23:47

Channel 39

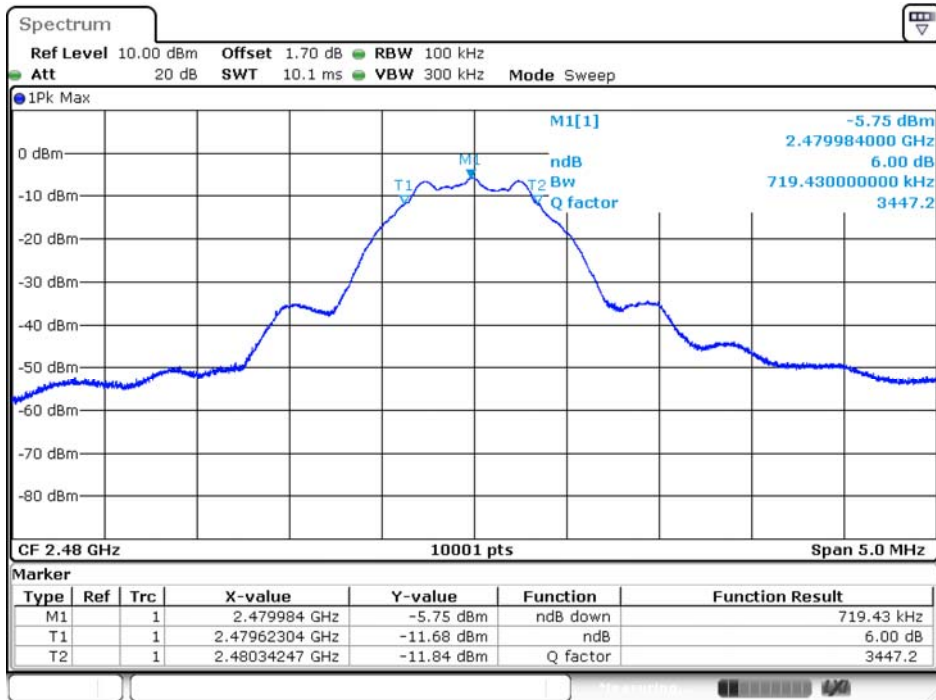

Date: 4.DEC.2018 20:21:58

8. Power Density

8.1. Test Setup

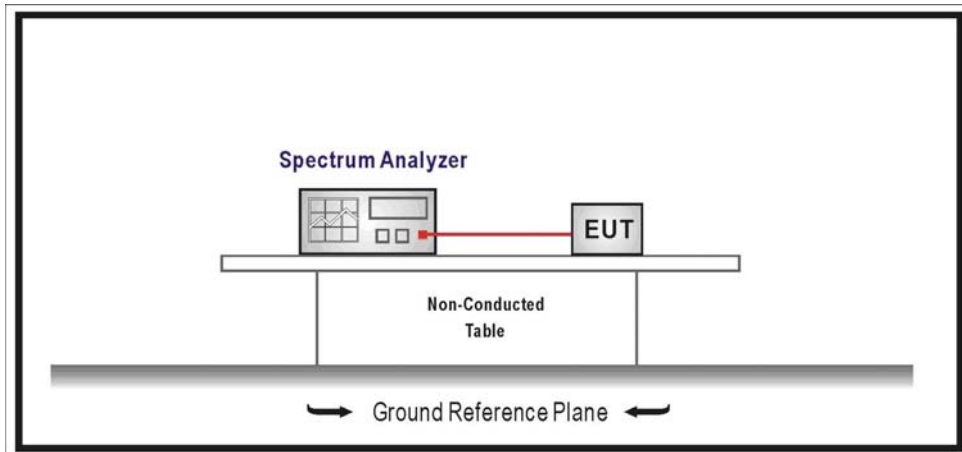

8.2. Limits

The peak power spectral density conducted from the intentional radiated to the antenna shall not be greater than +8dBm in any 3kHz band during any time interval of continuous transmission.

8.3. Test Procedures

The EUT was setup according to ANSI C63.10: 2013; tested according to DTS test procedure of KDB558074 V05 for compliance to FCC 47CFR 15.247 requirements.

8.4. Test Specification

According to FCC Part 15 Subpart C Paragraph 15.247 and ISED RSS-247.

8.5. Test Result

Product	Cycling computer		
Test Item	Power Density		
Test Mode	Mode 1: Transmit_Power by PC		
Date of Test	2018/12/04	Test Site	SR10-H

Channel No.	Frequency (MHz)	Measure Vaule (dBm/3kHz)	Limit (dBm/3kHz)
0	2402	-23.220	≤ 8
19	2440	-20.790	≤ 8
39	2480	-21.200	≤ 8

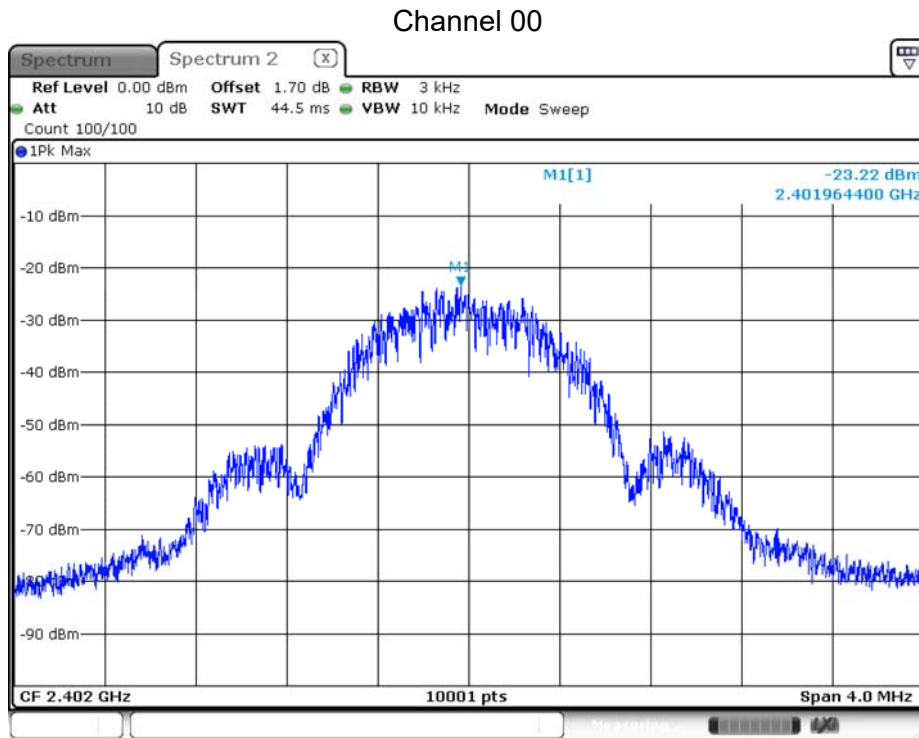

Date: 4.DEC.2018 13:36:53

Channel 19

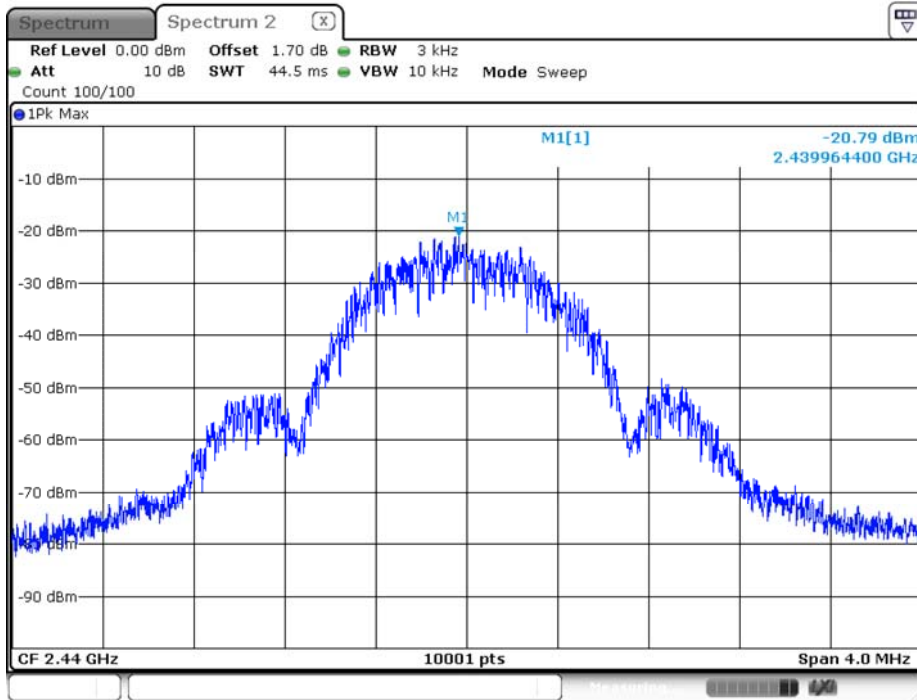

Date: 4.DEC.2018 13:40:51

Channel 39

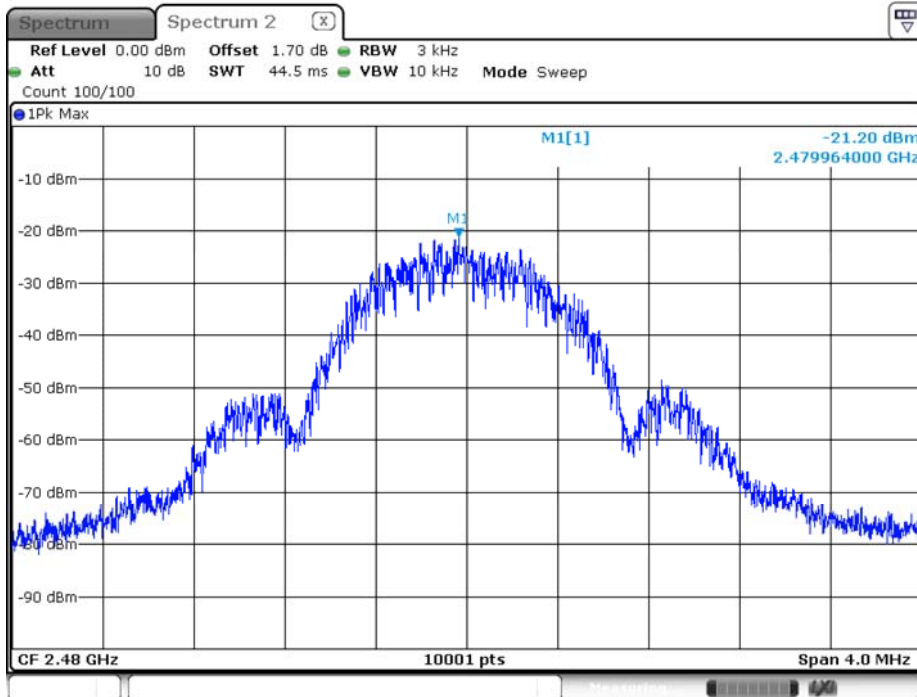

Date: 4.DEC.2018 13:41:39