

FCC/ISED Test Report

Product Name : Bicycle Light
Trade Name : LEZYNE
Model No. : SUPER DRIVE, MEGA DRIVE
FCC ID : 2AD4S-1LED7V3
IC : 20084-1LED7V3

Applicant : Lezyne USA, Incorporated (FCC)
LEZYNE USA, INC. (ISED)
Address : 645 Tank Farm Road Unit F, San Luis Obispo,
California, 93401, United States (FCC)
645 Tank Farm Road, Unit F, San Luis Obispo, CA
93401 United States Of America (ISED)

Date of Receipt : Nov. 19, 2019
Issued Date : Feb. 11, 2020
Report No. : 19B0252R-RFUSP01V00
Report Version : V1.0



The test results relate only to the samples tested.
The test report shall not be reproduced except in full without the written approval of DEKRA Testing and Certification Co., Ltd.

Test Report Certification

Issued Date : Feb. 11, 2020

Report No. : 19B0252R-RFUSP01V00



Product Name : Bicycle Light
 Applicant/Manufacturer : Lezyne USA, Incorporated (FCC)
 LEZYNE USA, INC. (ISED)
 Applicant/Manufacturer : 645 Tank Farm Road Unit F, San Luis Obispo, California, 93401,
 United States (FCC)
 Address : 645 Tank Farm Road, Unit F, San Luis Obispo, CA 93401 United States Of America (ISED)

Trade Name : LEZYNE
 Model No. : SUPER DRIVE, MEGA DRIVE
 FCC ID : 2AD4S-1LED7V3
 IC : 20084-1LED7V3
 EUT Voltage : DC 3.7V(Power by Battery)
 Testing Voltage : AC 120V/60Hz (Power by Adapter & PC)
 DC 3.7V (Power by Battery) & DC 5V (Power Bank)

Applicable Standard : FCC CFR Title 47 Part 15 Subpart C Section 15.247: 2018
 RSS-GEN Issue 5 (Amendment 1, March 2019)
 RSS-247 Issue 2 (Feb. 2017)
 ANSI C63.10: 2013

Laboratory Name : Hsin Chu Laboratory
 Address : No.372-2, Sec. 4, Zhongxing Rd., Zhudong Township, Hsinchu County 310, Taiwan, R.O.C.
 TEL: +886-3-582-8001 / FAX: +886-3-582-8958

Test Result : Complied

Documented By : 

 (Demi Chang / Senior Engineering Adm. Specialist)

Tested By : 

 (Scott Chang / Engineer)

Approved By : 

 (Louis Hsu / Deputy Manager)

Revision History

Report No.	Version	Description	Issued Date
19B0252R-RFUSP01V00	V1.0	Initial issue of report	Feb. 11, 2020

TABLE OF CONTENTS

Description	Page
1. General Information.....	6
1.1. EUT Description	6
1.2. Test Mode	7
1.3. Tested System Details	8
1.4. Configuration of tested System	9
1.5. EUT Exercise Software	12
1.6. Test Facility.....	13
1.7. List of Test Equipment	15
1.8. Duty cycle	17
1.9. Uncertainty	18
2. Conducted Emission	19
2.1. Test Setup.....	19
2.2. Limits	19
2.3. Test Procedure	20
2.4. Test Specification.....	20
2.5. Test Result.....	21
3. Maximum peak conducted output power.....	25
3.1. Test Setup.....	25
3.2. Test procedures	25
3.3. Limits	25
3.4. Test Specification.....	25
3.5. Test Result.....	26
4. Radiated Emission	27
4.1. Test Setup.....	27
4.2. Limits	28
4.3. Test Procedure	29
4.4. Test Specification.....	29
4.5. Test Result.....	30
5. RF antenna conducted test	44
5.1. Test Setup.....	44
5.2. Limits	44
5.3. Test Procedure	44
5.4. Test Specification.....	44
5.5. Test Result.....	45
6. Radiated Emission Band Edge.....	49
6.1. Test Setup.....	49
6.2. Limits	49
6.3. Test Procedure	49
6.4. Test Specification.....	49
6.5. Test Result.....	50
7. Occupied Bandwidth & DTS Bandwidth	56
7.1. Test Setup.....	56

7.2.	Limits	56
7.3.	Test Procedures.....	56
7.4.	Test Specification.....	56
7.5.	Test Result.....	57
8.	Power Density	61
8.1.	Test Setup.....	61
8.2.	Limits	61
8.3.	Test Procedures.....	61
8.4.	Test Specification.....	61
8.5.	Test Result.....	62
Attachment 1	64
	Test Setup Photograph.....	64
Attachment 2	71
	EUT External Photograph.....	71
Attachment 3	75
	EUT Internal Photograph.....	75

1. General Information

1.1. EUT Description

Product Name	Bicycle Light
Trade Name	LEZYNE
Model No.	SUPER DRIVE, MEGA DRIVE
Frequency Range/Channel Number	2402~2480MHz / 40 Channels
Type of Modulation	GFSK

Antenna Information	
Antenna Type	PCB Antenna
Antenna Gain	-2.4 dBi

Working Frequency of Each Channel							
Channel	Frequency	Channel	Frequency	Channel	Frequency	Channel	Frequency
Channel 00	2402 MHz	Channel 10	2422 MHz	Channel 20	2442 MHz	Channel 30	2462 MHz
Channel 01	2404 MHz	Channel 11	2424 MHz	Channel 21	2444 MHz	Channel 31	2464 MHz
Channel 02	2406 MHz	Channel 12	2426 MHz	Channel 22	2446 MHz	Channel 32	2466 MHz
Channel 03	2408 MHz	Channel 13	2428 MHz	Channel 23	2448 MHz	Channel 33	2468 MHz
Channel 04	2410 MHz	Channel 14	2430 MHz	Channel 24	2450 MHz	Channel 34	2470 MHz
Channel 05	2412 MHz	Channel 15	2432 MHz	Channel 25	2452 MHz	Channel 35	2472 MHz
Channel 06	2414 MHz	Channel 16	2434 MHz	Channel 26	2454 MHz	Channel 36	2474 MHz
Channel 07	2416MHz	Channel 17	2436 MHz	Channel 27	2456 MHz	Channel 37	2476 MHz
Channel 08	2418 MHz	Channel 18	2438 MHz	Channel 28	2458 MHz	Channel 38	2478 MHz
Channel 09	2420 MHz	Channel 19	2440 MHz	Channel 29	2460 MHz	Channel 39	2480 MHz

Note:

1. This device is a Bicycle Light supports BT 5.0 (1Mbps only) transmitting and receiving function.
2. The difference of models is only on brightness, based on SW to control. The HW, Layout, Component, and Material all the same.
3. The EUT description is from the customer declaration.
4. Regards to the frequency band operation; the lowest 、 middle and highest frequency of channel were selected to perform the test, and then shown on this report.

1.2. Test Mode

DEKRA has verified the construction and function in typical operation. All the test modes were carried out with the EUT in transmitting operation, which was shown in this test report and defined as follows:

Test Mode	Mode 1 : Transmit Mode_Power by Adapter Mode 2 : Transmit Mode_Power by PC Mode 3 : Transmit Mode_Power by Power Bank Mode 4 : Transmit Mode_Power by Battery
-----------	--

Test Items	Modulation	Channel	Result
Conducted Emission	GFSK	19	Complies
Maximum peak conducted output power	GFSK	00/19/39	Complies
Radiated Emission	GFSK	00/19/39	Complies
RF antenna conducted test	GFSK	00/19/39	Complies
Radiated Emission Radiated Emission Band Edge	GFSK	00/19/39	Complies
Occupied Bandwidth & DTS Bandwidth	GFSK	00/19/39	Complies
Power Density	GFSK	00/19/39	Complies

Note: Determining compliance shall be based on the results of the compliance measurement, not taking into account measurement instrumentation uncertainty.

1.3. Tested System Details

The types for all equipment, plus descriptions of all cables used in the tested system (including inserted cards) are:

Product	Manufacturer	Model No.	Serial No.	FCC ID	Power Cord	
1	Notebook PC	Lenovo	80T7	PF0MEEB0	DoC	Shielded, 1.8m, one ferrite core bonded
2	Fixture	PU-YANG	0800A	K2812	DoC	--
3	Wideband Radio Communication Tester	R&S	CMW500	150246	DoC	Non-Shielded, 1.8m
4	Adapter	PRO Power	TM-K018VA-00 502100PH-Z	N/A	DoC	--
5	Power Bank	LEZYNE	INFINITE LIGHT POWER PACK	N/A	DoC	--

1.4. Configuration of tested System

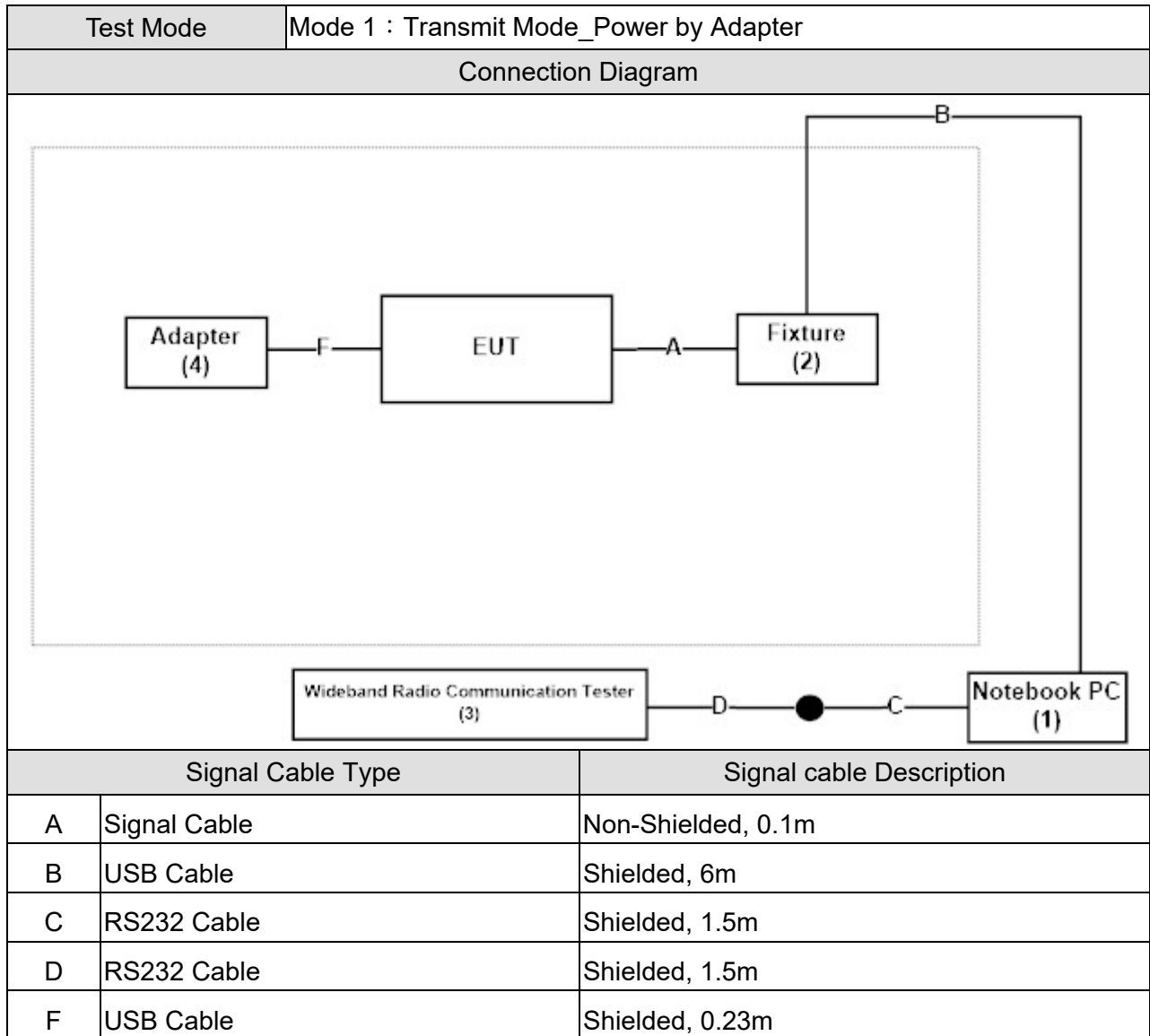

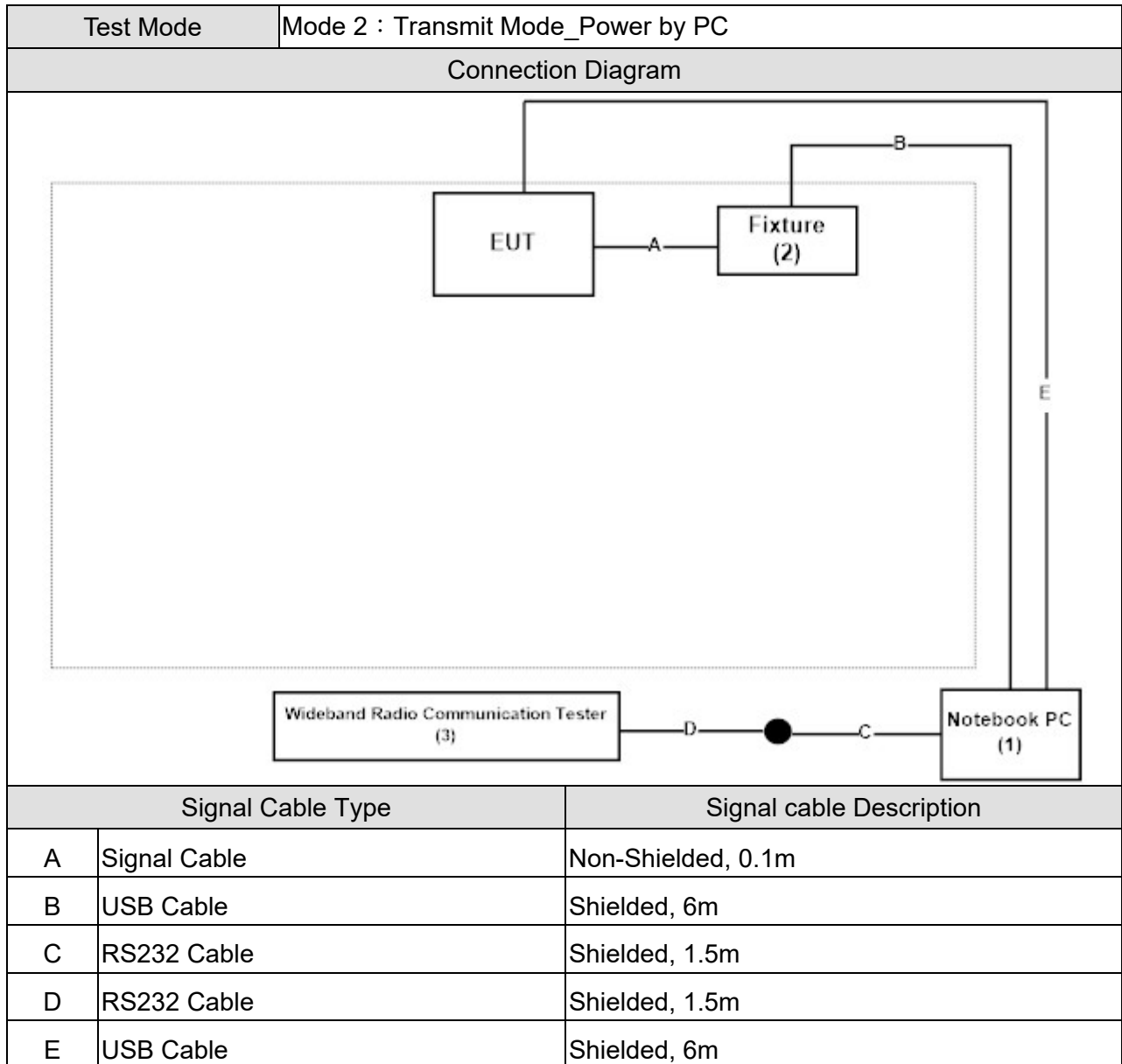

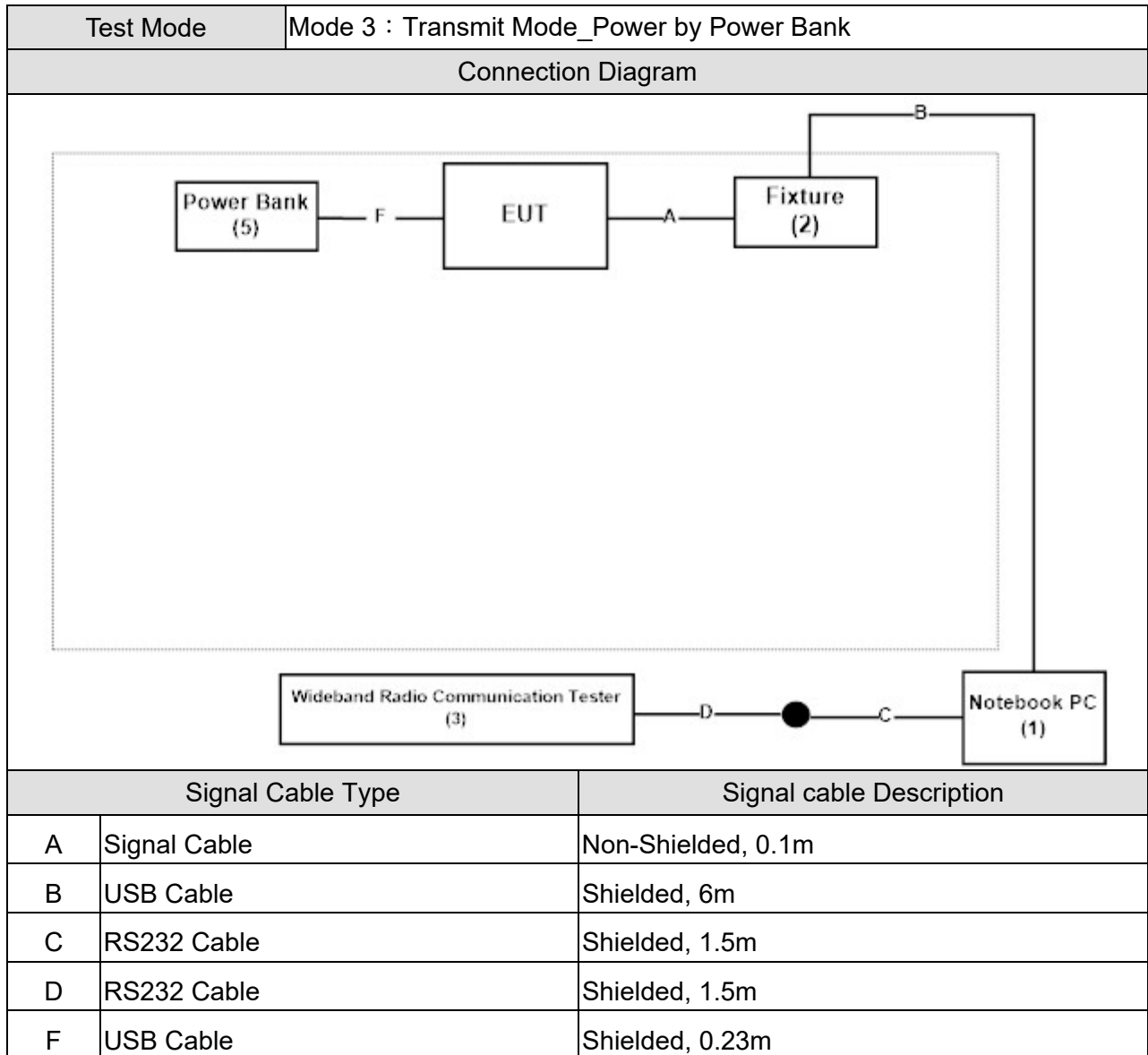

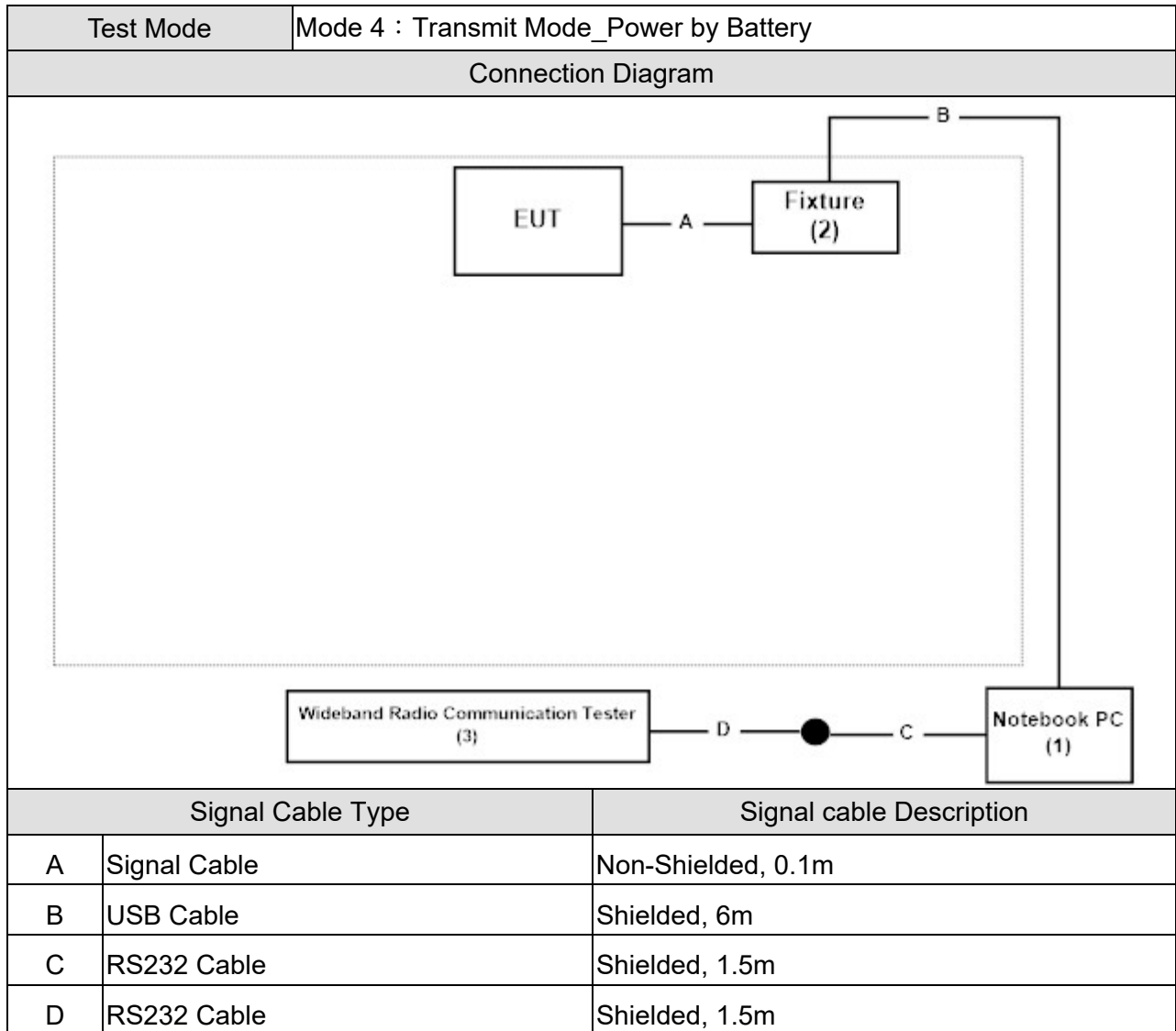

1.5. EUT Exercise Software

1	Setup the EUT as shown in Section 1.4.
2	Execute the “ComTransfer” on the laptop.
3	Configure the test mode, the test channel, and the data rate.
4	Press “Start TX” to start the continuous transmitting.
5	Verify that the EUT works properly.

1.6. Test Facility

Ambient conditions in the laboratory:

Items	Test Item	Required	Test Site
Temperature (°C)	FCC PART 15 C 15.207	15 - 35	3
Humidity (%RH)	Conducted Emission	25 - 75	
Temperature (°C)	FCC PART 15 C 15.247	15 - 35	3
Humidity (%RH)	Maximum peak conducted output power	25 - 75	
Temperature (°C)	FCC PART 15 C 15.247	15 - 35	2
Humidity (%RH)	Radiated Emission	25 - 75	
Temperature (°C)	FCC PART 15 C 15.247	15 - 35	3
Humidity (%RH)	RF antenna conducted test	25 - 75	
Temperature (°C)	FCC PART 15 C 15.247	15 - 35	2
Humidity (%RH)	Radiated Emission Band Edge	25 - 75	
Temperature (°C)	FCC PART 15 C 15.247	15 - 35	3
Humidity (%RH)	Occupied Bandwidth & DTS Bandwidth	25 - 75	
Temperature (°C)	FCC PART 15 C 15.247	15 - 35	3
Humidity (%RH)	Power Density	25 - 75	

Note: Test site information refers to Laboratory Information.

Laboratory Information

USA : **FCC Registration Number: TW3024**
Canada : **IC Registration Number: 22397-1 / 22397-2 / 22397-3**

The address and introduction of DEKRA Testing and Certification Co., Ltd. laboratories can be founded in our Web site : <http://www.dekra.com.tw>

If you have any comments, please don't hesitate to contact us. Our test sites as below:

Test Laboratory	DEKRA Testing and Certification Co., Ltd.
Address	<ol style="list-style-type: none"> 1. No. 75-2, 3rd Lin, WangYe Keng, Yonghxing Tsuen, Qionglin Shiang, Hsinchu County 307, Taiwan, R.O.C. 2. No.372, Sec. 4, Zhongxing Rd., Zhudong Township, Hsinchu County 31061, Taiwan, R.O.C. 3. No.372-2, Sec. 4, Zhongxing Rd., Zhudong Township, Hsinchu County 31061, Taiwan, R.O.C.
Phone number	<ol style="list-style-type: none"> 1. +886-3-592-8858 2. +886-3-582-8001 3. +886-3-582-8001
Fax number	<ol style="list-style-type: none"> 1. +886-3-592-8859 2. +886-3-582-8958 3. +886-3-582-8958
E mail address	info.tw@dekra.com
Website	http://www.dekra.com.tw

1.7. List of Test Equipment

Conducted Emission / SR2-H

Instrument	Manufacturer	Model No.	Serial No.	Cal. Date	Next Cal. Date
Artificial Mains Network	R&S	ENV4200	848411/010	2019/01/11	2020/01/10
Test Receiver	R&S	ESCS 30	836858/022	2019/03/12	2020/03/11
LISN	R&S	ENV216	100092	2019/07/09	2020/07/08

Maximum peak conducted output power / SR12-H

Instrument	Manufacturer	Model No.	Serial No.	Cal. Date	Next Cal. Date
High Speed Peak Power Meter Dual Input	Anritsu	ML2496A	1602004	2019/12/02	2020/12/01
Pulse Power Sensor	Anritsu	MA2411B	1531043	2019/12/02	2020/12/01
Pulse Power Sensor	Anritsu	MA2411B	1531044	2019/12/02	2020/12/01
Power Meter	Keysight	8990B	MY51000248	2019/05/21	2020/05/20
Power Sensor	Keysight	N1923A	MY57240005	2019/05/21	2020/05/20

Radiated Emission / CB4-H

Instrument	Manufacturer	Model No.	Serial No.	Cal. Date	Next Cal. Date
Signal Analyzer	R&S	FSVA40	101455	2019/10/21	2020/10/20
Signal & Spectrum Analyzer	R&S	FSV40	101049	2019/09/11	2020/09/10
EXA Signal Analyzer	Keysight	N9010A	MY51440132	2019/03/15	2020/03/14
Bilog Antenna	Teseq	CBL6112D	23191	2019/06/17	2020/06/16
Horn Antenna	Schwarzbeck	BBHA 9120D	639	2019/05/28	2020/05/27
Horn Antenna	Schwarzbeck	BBHA 9170	202	2019/12/27	2020/12/26
Pre-Amplifier	DEKRA	AP-025C	12183122	2019/09/24	2020/09/23
Pre-Amplifier	EMCI	EMC11830I	980366	2019/12/03	2020/12/02
Pre-Amplifier	DEKRA	AP-400C	201801231	2019/12/03	2020/12/02
Horn Antenna	Schwarzbeck	BBHA 9120D	01656	2019/10/25	2020/10/24
Band Reject Filter	Micro-Tronics	BRM50702	G192	2019/03/27	2020/03/26
Signal Analyzer	R&S	FSV40	101435	2019/07/08	2020/07/07
Coaxial Cable(19m)	Suhner	SF102_SF104_SF106	CB4_2	2019/07/25	2020/07/24
EMI system	DEKRA	Version 1.0	CB4-H	NA	NA

RF antenna conducted test / SR12-H

Instrument	Manufacturer	Model No.	Serial No.	Cal. Date	Next Cal. Date
Spectrum Analyzer	Keysight	N9030B	MY57140404	2019/06/18	2020/06/17
Spectrum Analyzer	Keysight	N9010B	MY57110159	2019/05/03	2020/05/02
Spectrum Analyzer	Agilent	N9010A	US47140172	2019/06/28	2020/06/27
Signal & Spectrum Analyzer	R&S	FSV40	101049	2019/09/11	2020/09/10

Radiated Emission Band Edge / CB4-H

Instrument	Manufacturer	Model No.	Serial No.	Cal. Date	Next Cal. Date
Signal Analyzer	R&S	FSVA40	101455	2019/10/21	2020/10/20
Signal & Spectrum Analyzer	R&S	FSV40	101049	2019/09/11	2020/09/10
EXA Signal Analyzer	Keysight	N9010A	MY51440132	2019/03/15	2020/03/14
Bilog Antenna	Teseq	CBL6112D	23191	2019/06/17	2020/06/16
Horn Antenna	Schwarzbeck	BBHA 9120D	639	2019/05/28	2020/05/27
Horn Antenna	Schwarzbeck	BBHA 9170	202	2019/12/27	2020/12/26
Pre-Amplifier	DEKRA	AP-025C	12183122	2019/09/24	2020/09/23
Pre-Amplifier	EMCI	EMC11830I	980366	2019/12/03	2020/12/02
Pre-Amplifier	DEKRA	AP-400C	201801231	2019/12/03	2020/12/02
Horn Antenna	Schwarzbeck	BBHA 9120D	01656	2019/10/25	2020/10/24
Band Reject Filter	Micro-Tronics	BRM50702	G192	2019/03/27	2020/03/26
Signal Analyzer	R&S	FSV40	101435	2019/07/08	2020/07/07
Coaxial Cable(19m)	Suhner	SF102_SF104_ SF106	CB4_2	2019/07/25	2020/07/24
EMI system	DEKRA	Version 1.0	CB4-H	NA	NA

Occupied Bandwidth & DTS Bandwidth / SR12-H

Instrument	Manufacturer	Model No.	Serial No.	Cal. Date	Next Cal. Date
Spectrum Analyzer	Keysight	N9030B	MY57140404	2019/06/18	2020/06/17
Spectrum Analyzer	Keysight	N9010B	MY57110159	2019/05/03	2020/05/02
Spectrum Analyzer	Agilent	N9010A	US47140172	2019/06/28	2020/06/27
Signal & Spectrum Analyzer	R&S	FSV40	101049	2019/09/11	2020/09/10

Power Density / SR12-H

Instrument	Manufacturer	Model No.	Serial No.	Cal. Date	Next Cal. Date
Spectrum Analyzer	Keysight	N9030B	MY57140404	2019/06/18	2020/06/17
Spectrum Analyzer	Keysight	N9010B	MY57110159	2019/05/03	2020/05/02
Spectrum Analyzer	Agilent	N9010A	US47140172	2019/06/28	2020/06/27
Signal & Spectrum Analyzer	R&S	FSV40	101049	2019/09/11	2020/09/10

Note: All equipment upon which need to calibrated are with calibration period of 1 year.

1.8. Duty cycle

Frequency	On Time (ms)	On+Off Time (ms)	Duty Cycle (%)	Duty Factor (dB) linear voltage	Power	1/T Minimum VBW (kHz)
2402	0.392	0.627	62.46%	4.087593	2.044	2.55

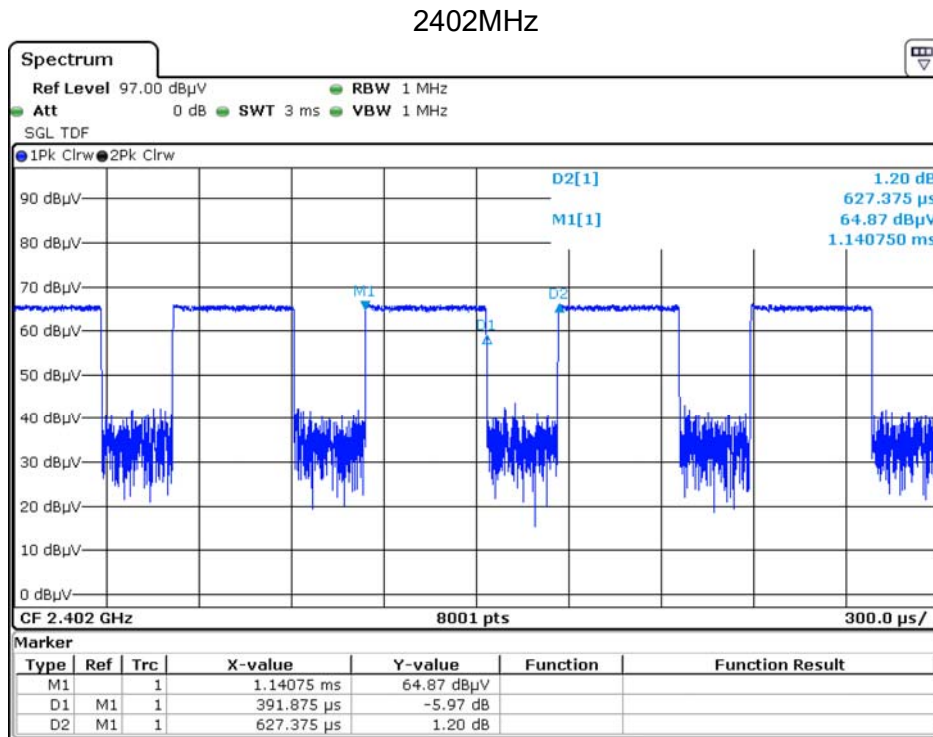

Date: 2.DEC.2019 16:37:32

1.9. Uncertainty

Test item	Uncertainty
Conducted Emission	± 2.26 dB
Maximum peak conducted output power	± 1.27 dB
Radiated Emission	30MHz~1GHz as ± 3.43 dB 1GHz~26.5GHz as ± 3.65 dB
RF antenna conducted test	± 1.27 dB
Radiated Emission Radiated Emission Band Edge	± 3.9 dB
Occupied Bandwidth & DTS Bandwidth	± 50 Hz
Power Density	± 1.27 dB

2. Conducted Emission

2.1. Test Setup

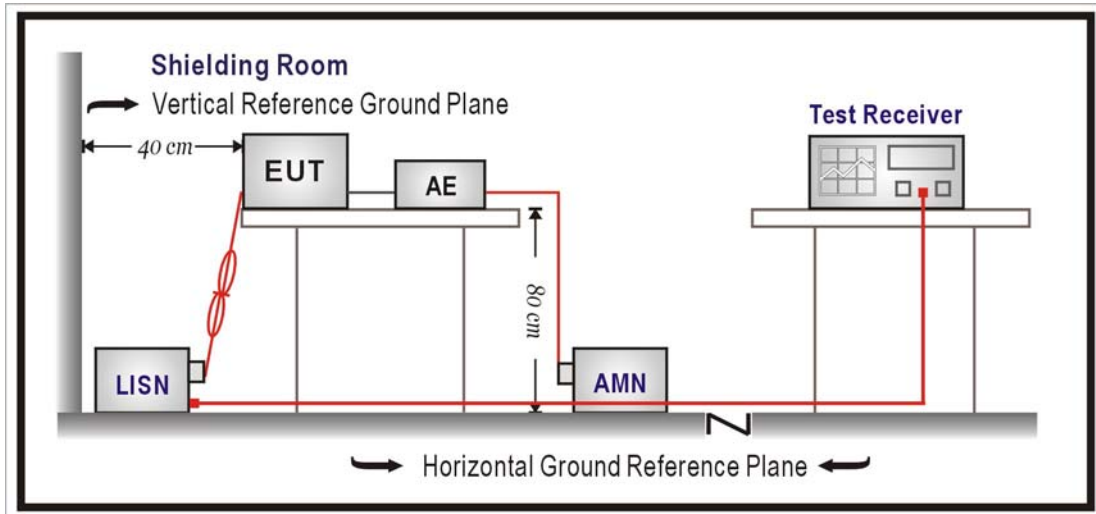

2.2. Limits

FCC Part 15 Subpart C Paragraph 15.207 Limits (dBuV)		
Frequency MHz	QP	AV
0.15 - 0.50	66 - 56	56 - 46
0.50 - 5.0	56	46
5.0 - 30	60	50

Remarks: In the above table, the tighter limit applies at the band edges.

2.3. Test Procedure

The EUT and simulators are connected to the main power through a line impedance stabilization network (L.I.S.N.). This provides a 50 ohm /50uH coupling impedance for the measuring equipment. The peripheral devices are also connected to the main power through a LISN that provides a 50ohm/50uH coupling impedance with 50ohm termination. (Please refer to the block diagram of the test setup and photographs.)

Both sides of A.C. line are checked for maximum conducted interference. In order to find the maximum emission, the relative positions of equipment and all of the interface cables must be changed according to ANSI C63.4: 2014 on conducted measurement.

Conducted emissions were investigated over the frequency range from 0.15MHz to 30MHz using a receiver bandwidth of 9KHz.

2.4. Test Specification

According to FCC Part 15 Subpart C Paragraph 15.207 and ISED RSS-247.

2.5. Test Result

Model No	SUPRE DEIVE,POWER DRIVE	Site	SR2-H
Test Voltage	AC 120V/60Hz	Test Date	2019/12/26
Test Mode	Mode 1 : Transmit Mode_Power by Adapter	Engineer	Scott
Phase	L1	Temperature (°C)	21.3
Test Condition	802.15.1_BLE	Humidity (%RH)	57
Note	CE-TX		

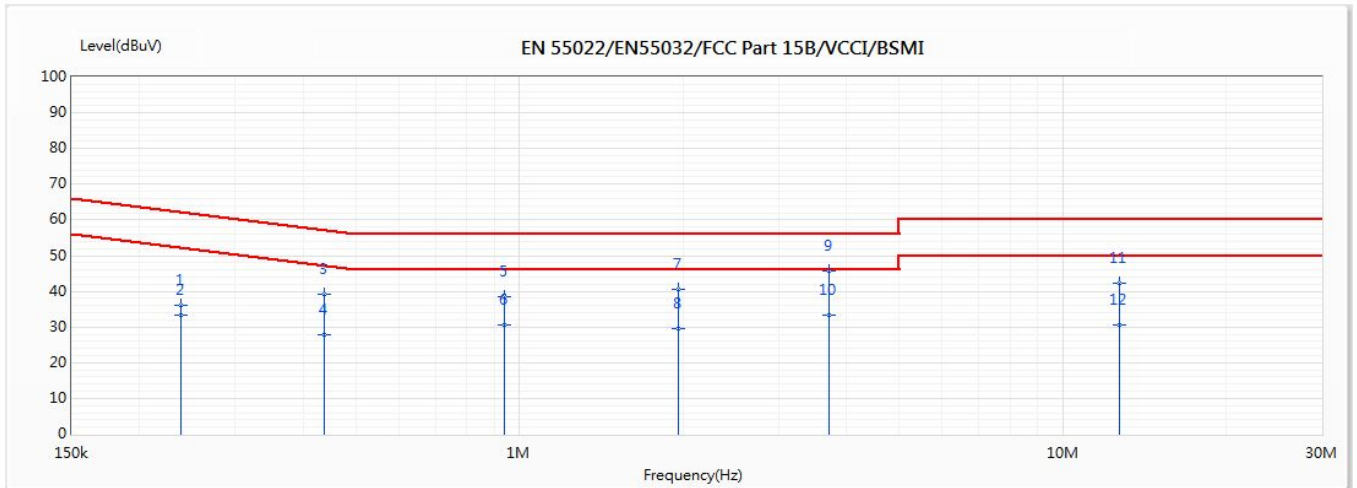

No	Frequency (MHz)	Emission Level (dBuV)	Limit (dBuV)	Margin (dB)	Reading Level (dBuV)	Correct Factor (dB)	Detector Type
1	0.238	36.11	63.47	-27.36	26.44	9.68	QP
2	0.238	33.19	53.47	-20.29	23.51	9.68	AV
3	0.437	39.30	57.80	-18.51	29.58	9.72	QP
4	0.437	27.96	47.80	-19.84	18.24	9.72	AV
5	0.94	38.53	56.00	-17.47	28.72	9.81	QP
6	0.94	30.42	46.00	-15.58	20.61	9.81	AV
7	1.965	40.55	56.00	-15.45	30.72	9.84	QP
8	1.965	29.56	46.00	-16.44	19.72	9.84	AV
*9	3.717	45.76	56.00	-10.24	35.87	9.89	QP
10	3.717	33.35	46.00	-12.65	23.47	9.89	AV
11	12.723	42.26	60.00	-17.74	32.11	10.15	QP
12	12.723	30.49	50.00	-19.51	20.34	10.15	AV

Note:

1. All Reading Levels are Quasi-Peak and average value.
2. " * ", means this data is the worst emission level.
3. Measurement Level = Reading Level + Correct Factor.

Model No	SUPRE DEIVE,POWER DRIVE	Site	SR2-H
Test Voltage	AC 120V/60Hz	Test Date	2019/12/26
Test Mode	Mode 1 : Transmit Mode_Power by Adapter	Engineer	Scott
Phase	L2	Temperature (°C)	21.3
Test Condition	802.15.1_BLE	Humidity (%RH)	57
Note	CE-TX		

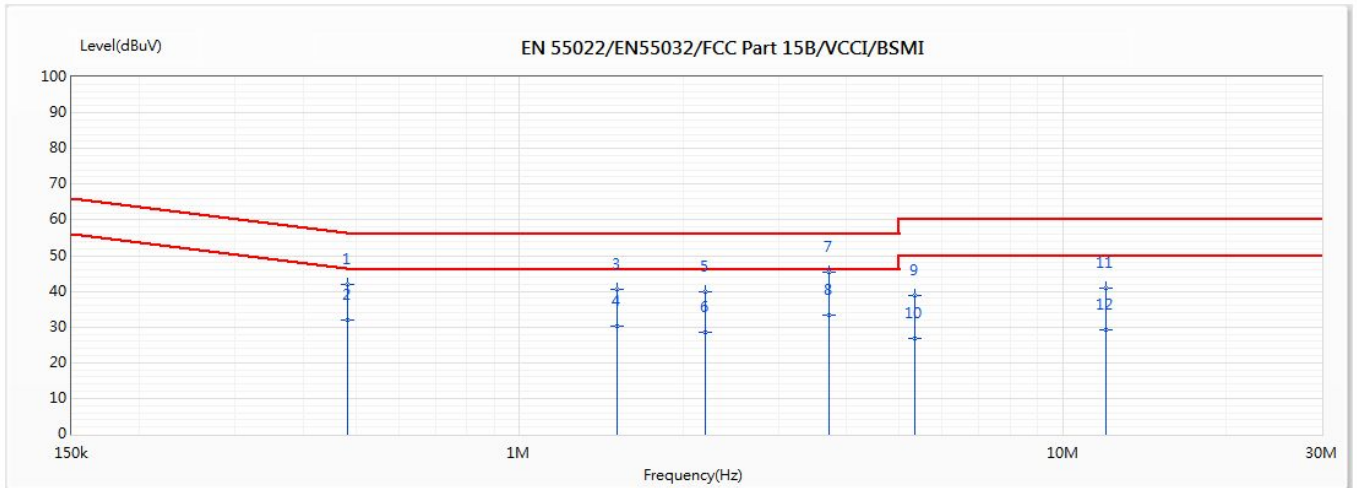

No	Frequency (MHz)	Emission Level (dBuV)	Limit (dBuV)	Margin (dB)	Reading Level (dBuV)	Correct Factor (dB)	Detector Type
1	0.482	41.98	56.51	-14.52	32.25	9.74	QP
2	0.482	31.93	46.51	-14.58	22.19	9.74	AV
3	1.515	40.66	56.00	-15.34	30.82	9.84	QP
4	1.515	30.16	46.00	-15.84	20.32	9.84	AV
5	2.204	39.86	56.00	-16.14	30.01	9.85	QP
6	2.204	28.53	46.00	-17.47	18.67	9.85	AV
*7	3.709	45.49	56.00	-10.51	35.60	9.90	QP
8	3.709	33.24	46.00	-12.76	23.34	9.90	AV
9	5.345	38.69	60.00	-21.31	28.74	9.95	QP
10	5.345	26.84	50.00	-23.16	16.89	9.95	AV
11	12.015	40.91	60.00	-19.09	30.70	10.21	QP
12	12.015	29.35	50.00	-20.65	19.14	10.21	AV

Note:

1. All Reading Levels are Quasi-Peak and average value.
2. " * ", means this data is the worst emission level.
3. Measurement Level = Reading Level + Correct Factor.

Model No	SUPRE DEIVE,POWER DRIVE	Site	SR2-H
Test Voltage	AC 120V/60Hz	Test Date	2019/12/26
Test Mode	Mode 2 : Transmit Mode_Power by PC	Engineer	Scott
Phase	L1	Temperature (°C)	21.3
Test Condition	802.15.1_BLE	Humidity (%RH)	57
Note	CE-TX		

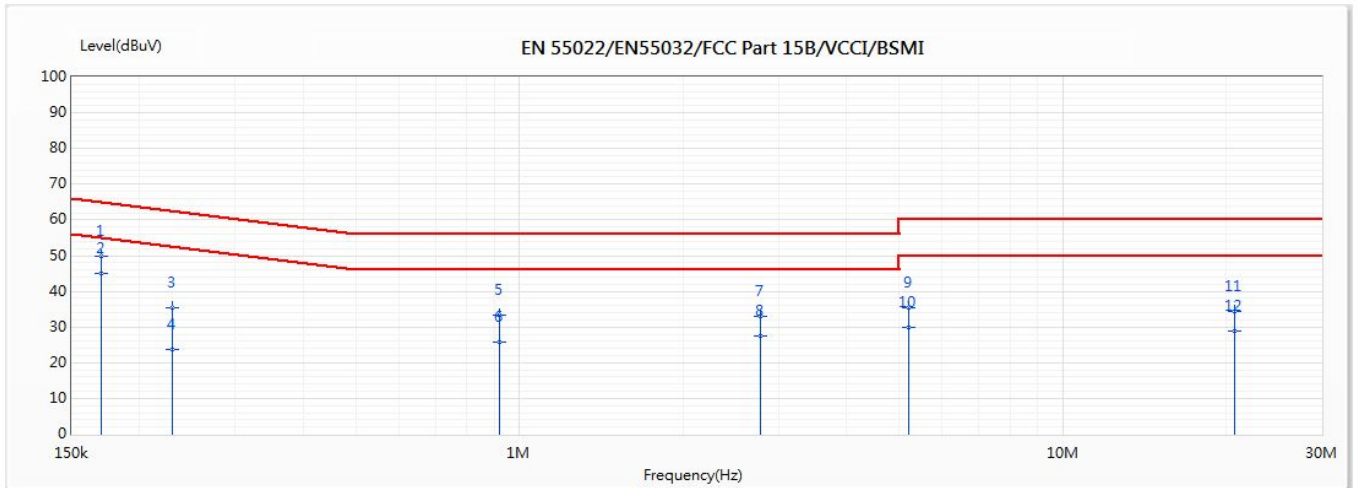

No	Frequency (MHz)	Emission Level (dBuV)	Limit (dBuV)	Margin (dB)	Reading Level (dBuV)	Correct Factor (dB)	Detector Type
1	0.17	49.81	65.43	-15.61	40.15	9.66	QP
*2	0.17	44.97	55.43	-10.46	35.30	9.66	AV
3	0.23	35.41	63.72	-28.31	25.73	9.68	QP
4	0.23	23.55	53.72	-30.16	13.88	9.68	AV
5	0.919	33.26	56.00	-22.74	23.46	9.81	QP
6	0.919	25.85	46.00	-20.15	16.05	9.81	AV
7	2.782	32.97	56.00	-23.03	23.11	9.86	QP
8	2.782	27.39	46.00	-18.61	17.53	9.86	AV
9	5.219	35.28	60.00	-24.72	25.35	9.93	QP
10	5.219	29.84	50.00	-20.16	19.92	9.93	AV
11	20.767	34.42	60.00	-25.58	24.15	10.28	QP
12	20.767	28.87	50.00	-21.13	18.59	10.28	AV

Note:

1. All Reading Levels are Quasi-Peak and average value.
2. " * ", means this data is the worst emission level.
3. Measurement Level = Reading Level + Correct Factor.

Model No	SUPRE DEIVE,POWER DRIVE	Site	SR2-H
Test Voltage	AC 120V/60Hz	Test Date	2019/12/26
Test Mode	Mode 2 : Transmit Mode_Power by PC	Engineer	Scott
Phase	L2	Temperature (°C)	21.3
Test Condition	802.15.1_BLE	Humidity (%RH)	57
Note	CE-TX		

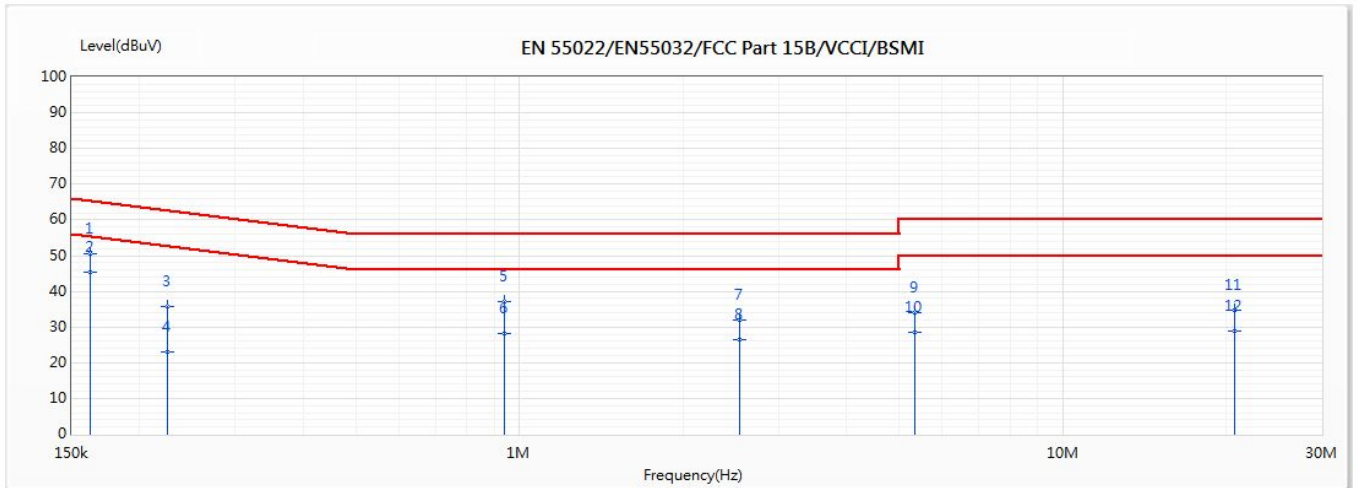

No	Frequency (MHz)	Emission Level (dBuV)	Limit (dBuV)	Margin (dB)	Reading Level (dBuV)	Correct Factor (dB)	Detector Type
1	0.162	50.50	65.65	-15.15	40.82	9.68	QP
*2	0.162	45.42	55.65	-10.23	35.74	9.68	AV
3	0.225	35.79	63.85	-28.06	26.10	9.69	QP
4	0.225	23.07	53.85	-30.78	13.38	9.69	AV
5	0.937	36.95	56.00	-19.05	27.14	9.81	QP
6	0.937	28.10	46.00	-17.90	18.29	9.81	AV
7	2.544	31.92	56.00	-24.08	22.06	9.87	QP
8	2.544	26.36	46.00	-19.64	16.49	9.87	AV
9	5.339	33.97	60.00	-26.03	24.02	9.95	QP
10	5.339	28.61	50.00	-21.39	18.66	9.95	AV
11	20.8	34.68	60.00	-25.32	24.22	10.47	QP
12	20.8	28.72	50.00	-21.28	18.26	10.47	AV

Note:

1. All Reading Levels are Quasi-Peak and average value.
2. " * ", means this data is the worst emission level.
3. Measurement Level = Reading Level + Correct Factor.

3. Maximum peak conducted output power

3.1. Test Setup

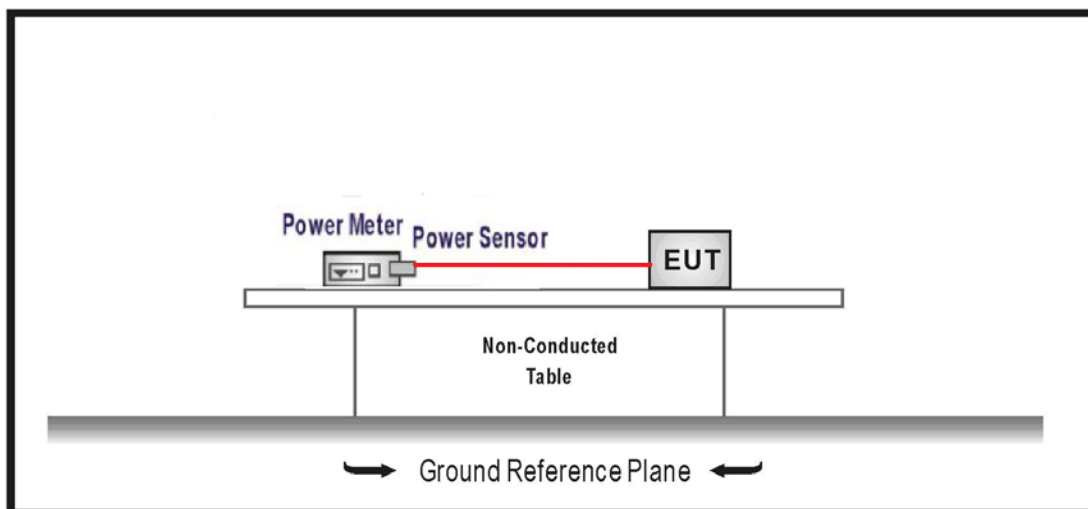

3.2. Test procedures

The EUT was setup according to ANSI C63.10: 2013; tested according to DTS test procedure of KDB558074 V05 r02 for compliance to FCC 47CFR 15.247 requirements.

3.3. Limits

The maximum peak power shall be less 1 Watt.

3.4. Test Specification

According to FCC Part 15 Subpart C Paragraph 15.247 and ISSED RSS-247.

3.5. Test Result

Product	Bicycle Light		
Test Item	Maximum peak conducted output power		
Test Mode	Mode 1 : Transmit Mode_Power by Adapter		
Date of Test	2019/12/25	Test Site	SR12-H
Temperature (°C)	21.5	Humidity (%RH)	55.0

Channel No.	Frequency (MHz)	Measure Level (dBm)	Limit (dBm)
00	2402	0.130	≤ 30
19	2440	-0.250	≤ 30
39	2480	-0.550	≤ 30

4. Radiated Emission

4.1. Test Setup

Under 30MHz Test Setup:

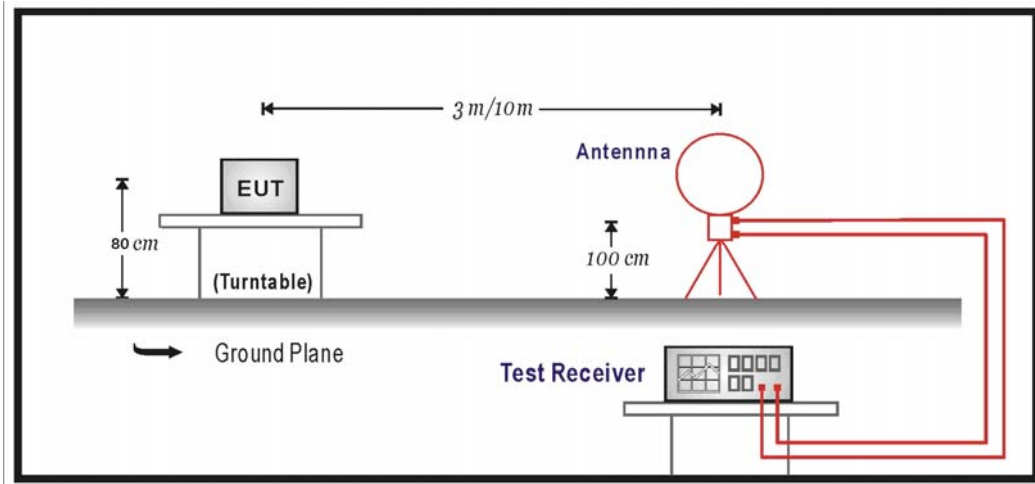

Under 1GHz Test Setup:

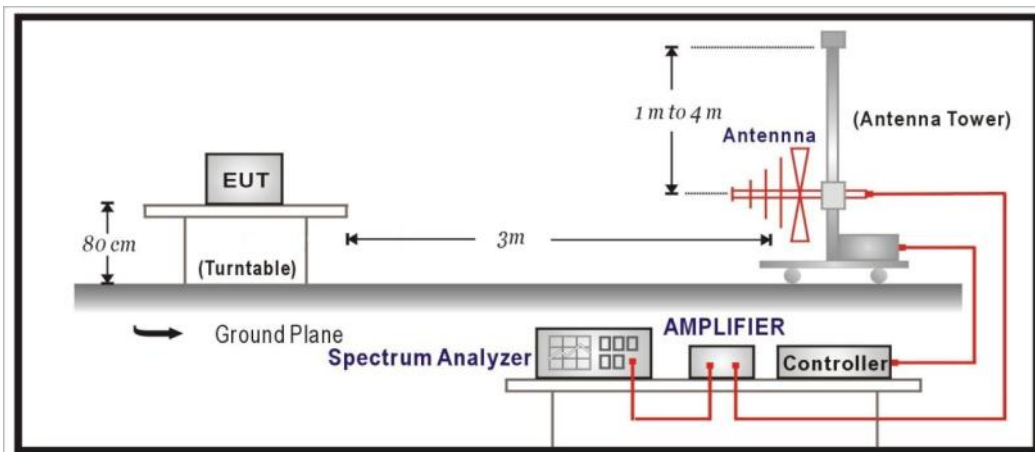

Above 1GHz Test Setup:

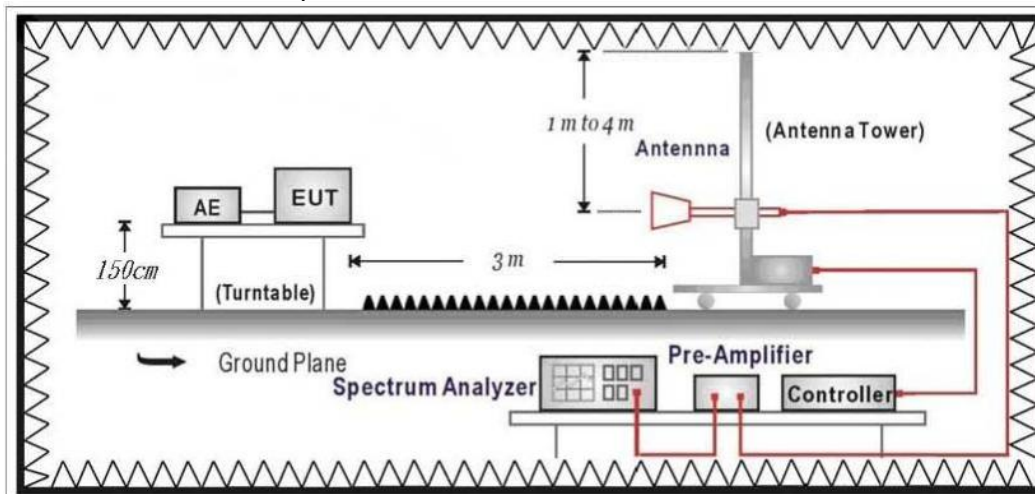

4.2. Limits

Emissions radiated outside of the specified frequency bands, except for harmonics, shall be attenuated by at least 20dB below the level of the fundamental or to the general radiated emission limits in paragraph 15.209, whichever is the lesser attenuation.

FCC Part 15 Subpart C Paragraph 15.209 Limits		
Frequency MHz	uV/m	dBuV/m
30 - 88	100	40
88 - 216	150	43.5
216 - 960	200	46
Above 960	500	54

- Remarks:
1. RF Voltage (dBuV) = 20 log RF Voltage (uV)
 2. In the Above Table, the tighter limit applies at the Radiated Emission Band Edges.
 3. Distance refers to the distance in meters between the measuring instrument antenna and the closed point of any part of the device or system.

4.3. Test Procedure

The EUT was setup according to ANSI C63.10: 2013 and tested according to DTS test procedure of KDB558074 V05 r02 for compliance to FCC 47CFR 15.247 requirements. The EUT and its simulators are placed on a turn table which is 0.8 or 1.5 meter above ground. The turn table can rotate 360 degrees to determine the position of the maximum emission level.

The antenna can move up and down between 1 meter and 4 meters to find out the maximum emission level.

Both horizontal and vertical polarization of the antenna are set on measurement. In order to find the maximum emission, all of the interface cables must be manipulated according to ANSI C63.10: 2013 on radiated measurement.

On any frequency or frequencies from 9KHz (include The the lowest oscillator frequency generated within the device up to the 10th harmonic) to 1000 MHz, the limits shown are based on measuring equipment employing a quasi-peak detector function and on any frequency or frequencies above 1000 MHz the radiated limits shown are based upon the use of measurement instrumentation employing an average detector function. When average radiated emission measurement are included emission measurement below 1000 MHz, there also is a limit on the radio frequency emissions, as measured using instrumentation with a peak detector function, corresponding to 20 dB above the maximum permitted average limit. The bandwidth below 1GHz setting on the field strength meter is 120 kHz and above 1GHz is 1MHz.

4.4. Test Specification

According to FCC Part 15 Subpart C Paragraph 15.247 and ISED RSS-247.

4.5. Test Result

30MHz-1GHz Spurious

Site :	CB4-H	Engineer :	Scott
Model No :	SUPER DRIVE, MEGA DRIVE	Test Date :	2019/12/25
Test Voltage :	AC 120V/60Hz	Polarity :	Horizontal
Test Mode :	Mode 1 : Transmit Mode_Power by Adapter		
Note :	802.15.1_BLE_2440MHz		
Environmental Condition:	Temperature (°C) : 21.3 ; Relative Humidity (%RH) : 51.0		

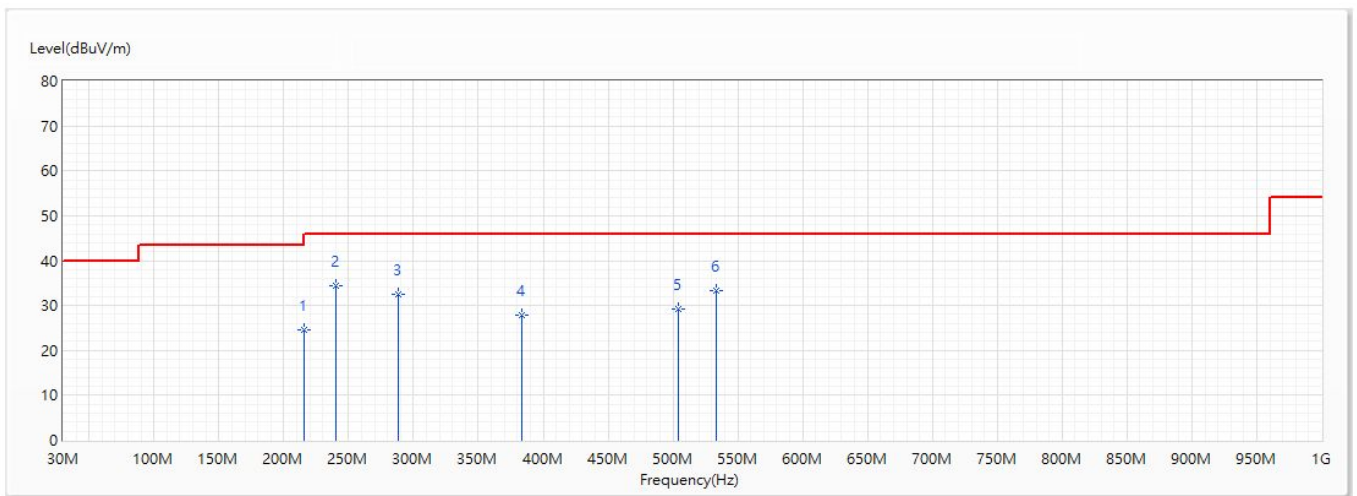

No	Frequency (MHz)	Emission Level (dBuV/m)	Limit (dBuV/m)	Margin (dB)	Reading Level (dBuV)	Correct Factor (dB/m)	Detector Type
1	215.998	24.64	43.50	-18.86	47.53	-22.89	QP
* 2	240.005	34.46	46.00	-11.54	55.95	-21.49	QP
3	287.899	32.48	46.00	-13.52	52.70	-20.22	QP
4	383.929	27.88	46.00	-18.12	45.08	-17.20	QP
5	503.966	29.27	46.00	-16.73	44.05	-14.78	QP
6	533.309	33.23	46.00	-12.77	47.61	-14.38	QP

Note:

1. All Reading Levels is Quasi-Peak value.
2. “ * ”, means this data is the worst emission level.
3. Emission Level = Reading Level + Correct Factor
4. The Emission under 30MHz were not included is because their levels are too low.

Site :	CB4-H	Engineer :	Scott
Model No :	SUPER DRIVE, MEGA DRIVE	Test Date :	2019/12/25
Test Voltage :	AC 120V/60Hz	Polarity :	Vertical
Test Mode :	Mode 1 : Transmit Mode_Power by Adapter		
Note :	802.15.1_BLE_2440MHz		
Environmental Condition:	Temperature (°C) : 22.0 ; Relative Humidity (%RH) : 52.0		

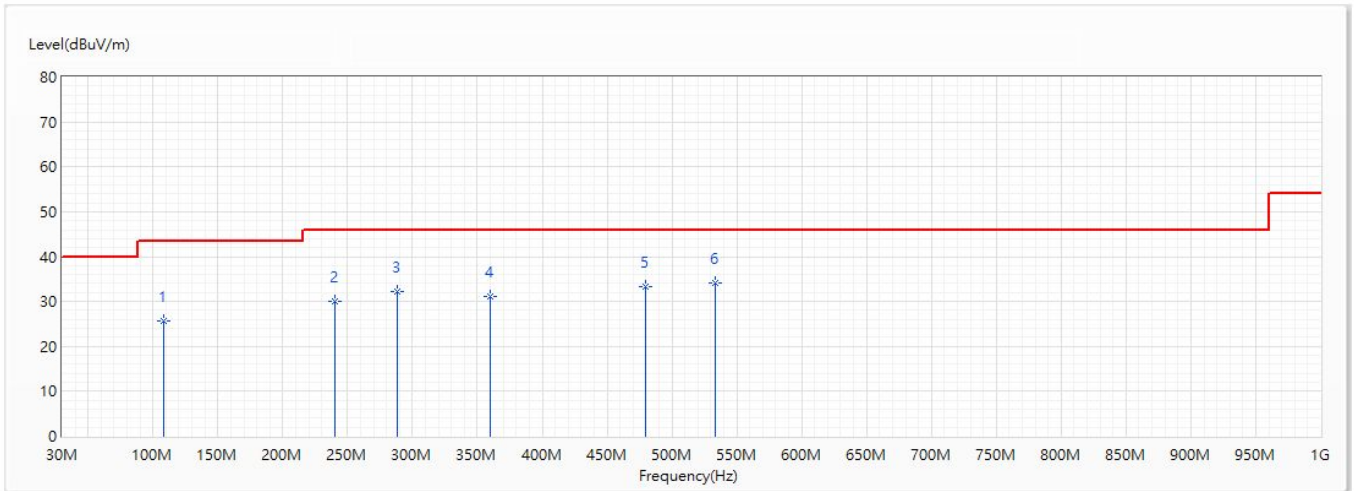

No	Frequency (MHz)	Emission Level (dBuV/m)	Limit (dBuV/m)	Margin (dB)	Reading Level (dBuV)	Correct Factor (dB/m)	Detector Type
1	107.964	25.54	43.50	-17.96	48.88	-23.34	QP
2	240.005	29.96	46.00	-16.04	51.45	-21.49	QP
3	288.02	32.13	46.00	-13.87	52.35	-20.22	QP
4	360.043	31.22	46.00	-14.78	49.21	-17.99	QP
5	479.959	33.30	46.00	-12.70	48.50	-15.20	QP
* 6	533.43	34.11	46.00	-11.89	48.49	-14.38	QP

Note:

1. All Reading Levels is Quasi-Peak value.
2. “ * ”, means this data is the worst emission level.
3. Emission Level = Reading Level + Correct Factor
4. The Emission under 30MHz were not included is because their levels are too low.

Model No	SUPER DRIVE, MEGA DRIVE	Site	CB4-H
Test Voltage	AC 120V/60Hz	Test Date	2019/12/25
Test Mode	Mode 2 : Transmit Mode_Power by PC	Engineer	Scott
Polarity	Horizontal	Temperature (°C)	21.3
Test Condition	802.15.1_BLE_2440MHz	Humidity (%RH)	51.0
Note	RE-TX		

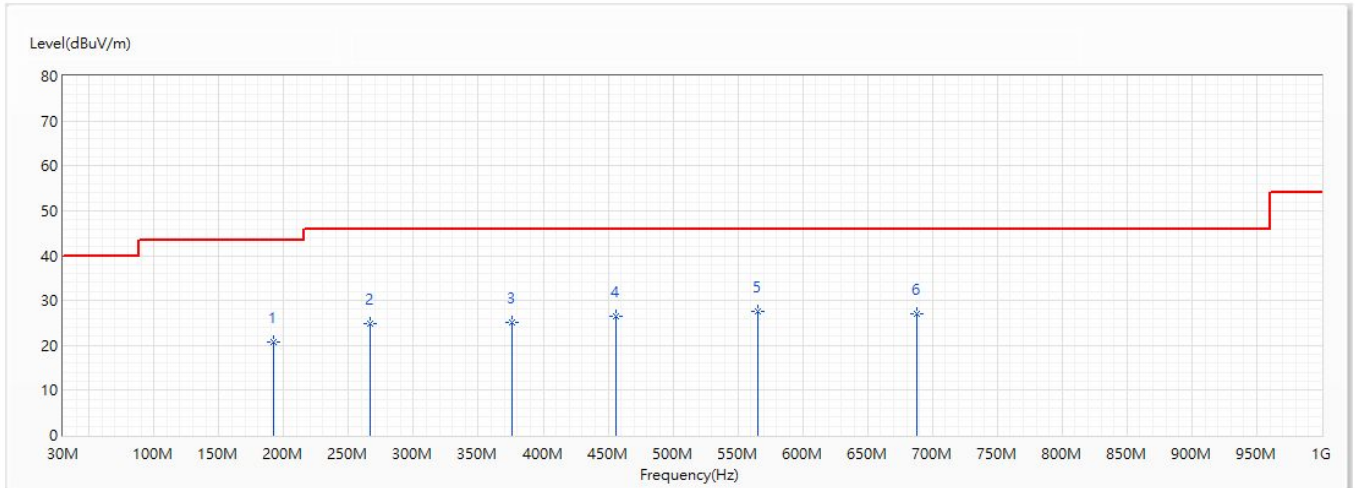

No	Frequency (MHz)	Emission Level (dBuV/m)	Limit (dBuV/m)	Margin (dB)	Reading Level (dBuV)	Correct Factor (dB/m)	Detector Type
1	192.354	20.69	43.50	-22.81	44.26	-23.57	QP
2	266.68	24.75	46.00	-21.25	45.34	-20.59	QP
3	375.563	25.04	46.00	-20.96	42.50	-17.46	QP
4	455.951	26.43	46.00	-19.57	42.07	-15.64	QP
* 5	565.198	27.55	46.00	-18.45	41.48	-13.93	QP
6	687.66	27.04	46.00	-18.96	39.79	-12.75	QP

Note:

1. All Reading Levels is Quasi-Peak value.
2. “ * ”, means this data is the worst emission level.
3. Emission Level = Reading Level + Correct Factor
4. The Emission under 30MHz were not included is because their levels are too low.

Model No :	SUPER DRIVE, MEGA DRIVE	Site	CB4-H
Test Voltage :	AC 120V/60Hz	Test Date	2019/12/25
Test Mode	Mode 2 : Transmit Mode_Power by PC	Engineer	Scott
Polarity	Vertical	Temperature (°C)	21.3
Test Condition	802.15.1_BLE_2440MHz	Humidity (%RH)	51.0
Note	RE-TX		

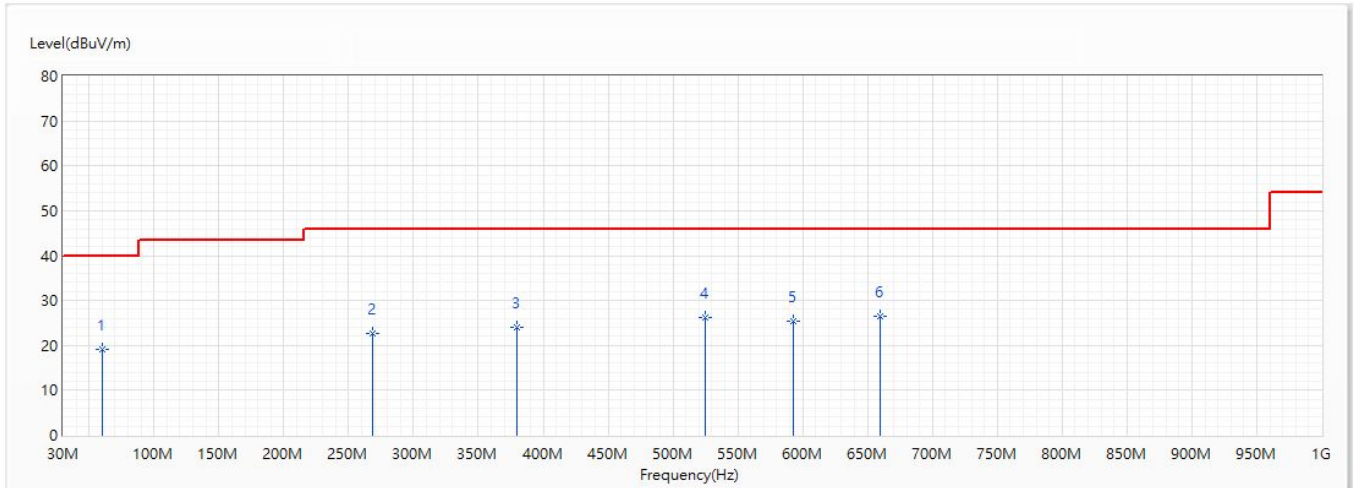

No	Frequency (MHz)	Emission Level (dBuV/m)	Limit (dBuV/m)	Margin (dB)	Reading Level (dBuV)	Correct Factor (dB/m)	Detector Type
1	60.07	19.13	40.00	-20.87	47.35	-28.22	QP
2	268.256	22.55	46.00	-23.45	43.12	-20.57	QP
3	379.443	24.08	46.00	-21.92	41.42	-17.34	QP
4	524.458	26.21	46.00	-19.79	40.72	-14.51	QP
5	593.206	25.44	46.00	-20.56	38.98	-13.54	QP
* 6	659.773	26.56	46.00	-19.44	39.52	-12.96	QP

Note:

1. All Reading Levels is Quasi-Peak value.
2. “ * ”, means this data is the worst emission level.
3. Emission Level = Reading Level + Correct Factor
4. The Emission under 30MHz were not included is because their levels are too low.

Site :	CB4-H	Engineer :	Scott
Model No :	SUPER DRIVE, MEGA DRIVE	Test Date :	2019/12/25
Test Voltage :	DC 5 V	Polarity :	Horizontal
Test Mode :	Mode 3 : Transmit Mode_Power by Power Bank		
Note :	802.15.1_BLE_2440MHz		
Environmental Condition:	Temperature (°C) : 21.3 ; Relative Humidity (%RH) : 51.0		

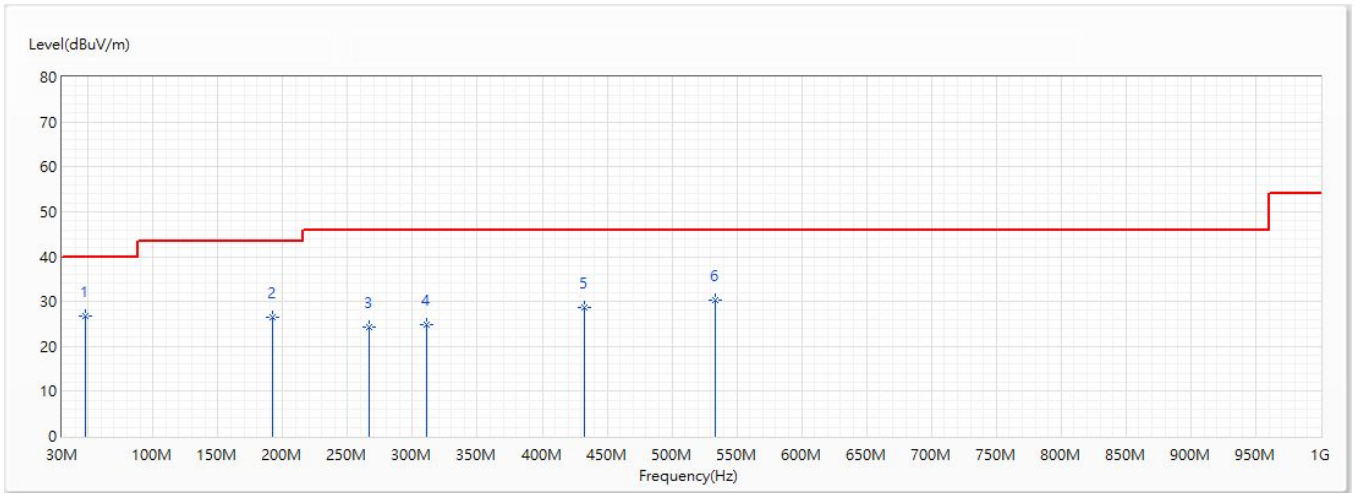

No	Frequency (MHz)	Emission Level (dBuV/m)	Limit (dBuV/m)	Margin (dB)	Reading Level (dBuV)	Correct Factor (dB/m)	Detector Type
* 1	48.066	26.77	40.00	-13.23	50.50	-23.73	QP
2	191.99	26.52	43.50	-16.98	50.08	-23.56	QP
3	266.559	24.19	46.00	-21.81	44.79	-20.60	QP
4	311.179	24.92	46.00	-21.08	44.56	-19.64	QP
5	432.065	28.80	46.00	-17.20	44.87	-16.07	QP
6	533.188	30.32	46.00	-15.68	44.70	-14.38	QP

Note:

1. All Reading Levels is Quasi-Peak value.
2. “ * ”, means this data is the worst emission level.
3. Emission Level = Reading Level + Correct Factor
4. The Emission under 30MHz were not included is because their levels are too low.

Site :	CB4-H	Engineer :	Scott
Model No :	SUPER DRIVE, MEGA DRIVE	Test Date :	2019/12/25
Test Voltage :	DC 5 V	Polarity :	Vertical
Test Mode :	Mode 3 : Transmit Mode_Power by Power Bank		
Note :	802.15.1_BLE_2440MHz		
Environmental Condition:	Temperature (°C) : 21.3 ; Relative Humidity (%RH) : 51.0		

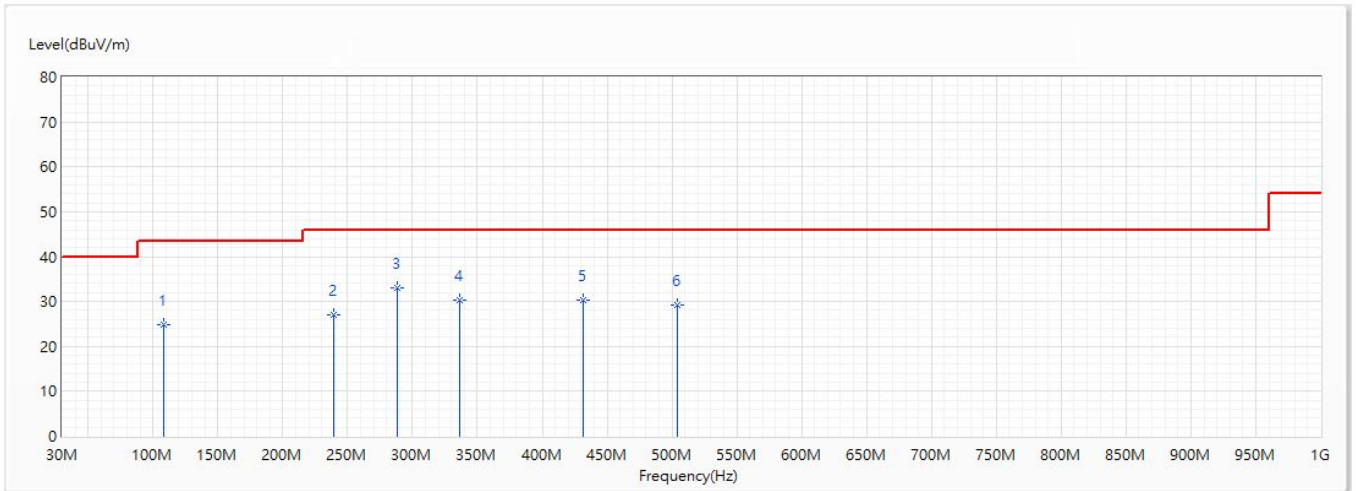

No	Frequency (MHz)	Emission Level (dBuV/m)	Limit (dBuV/m)	Margin (dB)	Reading Level (dBuV)	Correct Factor (dB/m)	Detector Type
1	107.843	24.71	43.50	-18.79	48.05	-23.34	QP
2	239.52	26.95	46.00	-19.05	48.46	-21.51	QP
* 3	288.02	33.11	46.00	-12.89	53.33	-20.22	QP
4	335.914	30.42	46.00	-15.58	49.21	-18.79	QP
5	431.944	30.37	46.00	-15.63	46.44	-16.07	QP
6	503.966	29.18	46.00	-16.82	43.96	-14.78	QP

Note:

1. All Reading Levels is Quasi-Peak value.
2. “ * ”, means this data is the worst emission level.
3. Emission Level = Reading Level + Correct Factor
4. The Emission under 30MHz were not included is because their levels are too low.

Site :	CB4-H	Engineer :	Scott
Model No :	SUPER DRIVE, MEGA DRIVE	Test Date :	2019/12/16
Test Voltage :	DC 3.7V	Polarity :	Horizontal
Test Mode :	Mode 4 : Transmit Mode_Power by Battery		
Note :	802.15.1_BLE_2440MHz		
Environmental Condition:	Temperature (°C) : 22.0 ; Relative Humidity (%RH) : 52.0		

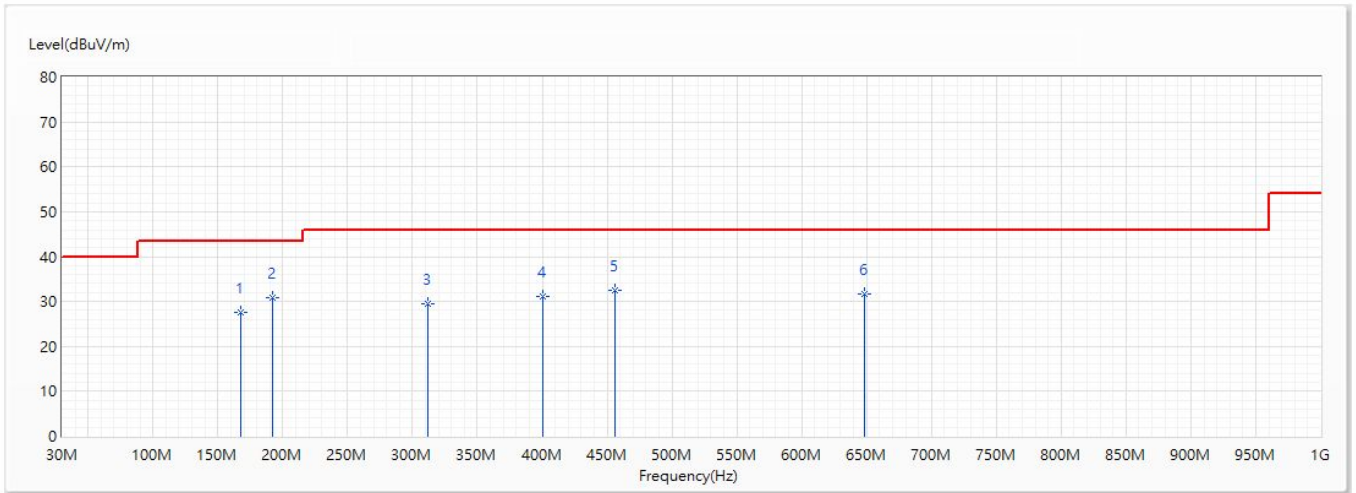

No	Frequency (MHz)	Emission Level (dBuV/m)	Limit (dBuV/m)	Margin (dB)	Reading Level (dBuV)	Correct Factor (dB/m)	Detector Type
1	167.983	27.59	43.50	-15.91	50.55	-22.96	QP
* 2	191.99	30.96	43.50	-12.54	54.52	-23.56	QP
3	312.028	29.53	46.00	-16.47	49.13	-19.60	QP
4	400.055	31.24	46.00	-14.76	47.89	-16.65	QP
5	456.073	32.46	46.00	-13.54	48.10	-15.64	QP
6	648.496	31.76	46.00	-14.24	44.82	-13.06	QP

Note:

1. All Reading Levels is Quasi-Peak value.
2. “ * ”, means this data is the worst emission level.
3. Emission Level = Reading Level + Correct Factor
4. The Emission under 30MHz were not included is because their levels are too low.

Site :	CB4-H	Engineer :	Scott
Model No :	SUPER DRIVE, MEGA DRIVE	Test Date :	2019/12/16
Test Voltage :	DC 3.7V	Polarity :	Vertical
Test Mode :	Mode 4 : Transmit Mode_Power by Battery		
Note :	802.15.1_BLE_2440MHz		
Environmental Condition:	Temperature (°C) : 22.0 ; Relative Humidity (%RH) : 52.0		

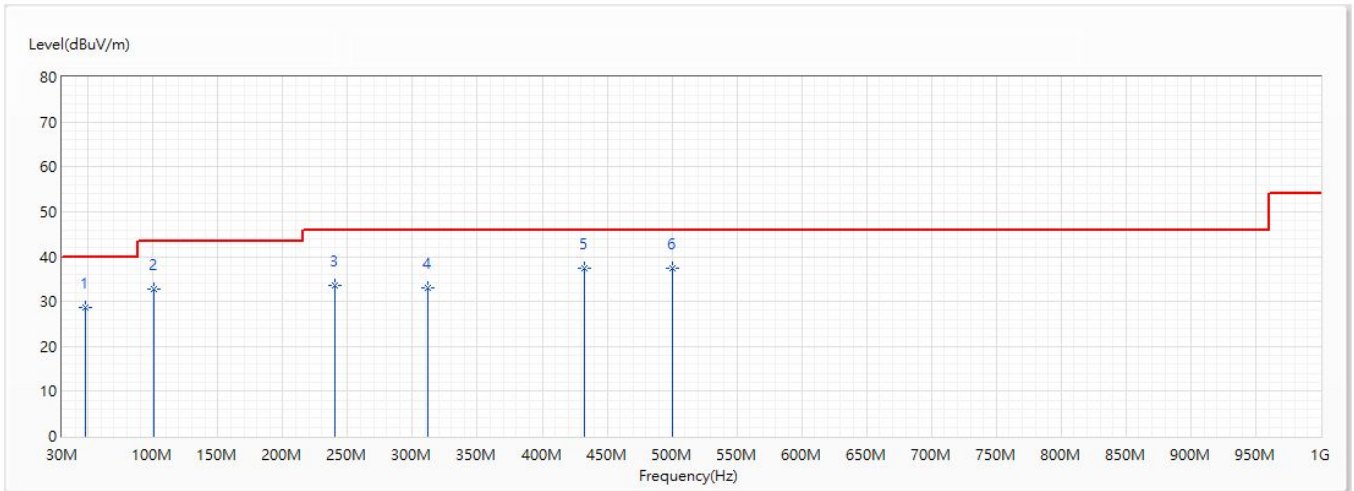

No	Frequency (MHz)	Emission Level (dBuV/m)	Limit (dBuV/m)	Margin (dB)	Reading Level (dBuV)	Correct Factor (dB/m)	Detector Type
1	48.066	28.76	40.00	-11.24	52.49	-23.73	QP
2	100.81	32.65	43.50	-10.85	56.13	-23.48	QP
3	240.005	33.67	46.00	-12.33	55.16	-21.49	QP
4	312.028	32.92	46.00	-13.08	52.52	-19.60	QP
5	432.065	37.29	46.00	-8.71	53.36	-16.07	QP
* 6	499.965	37.35	46.00	-8.65	52.20	-14.85	QP

Note:

1. All Reading Levels is Quasi-Peak value.
2. “ * ”, means this data is the worst emission level.
3. Emission Level = Reading Level + Correct Factor
4. The Emission under 30MHz were not included is because their levels are too low.

Harmonic & Spurious:

Site :	CB4-H	Engineer :	Scott
Model No :	SUPER DRIVE, MEGA DRIVE	Test Date :	2019/12/16
Test Voltage :	AC 120V/60Hz	Polarity :	Horizontal
Test Mode :	Mode 1 : Transmit Mode_Power by Adapter		
Note :	802.15.1_BLE_2402MHz		
Environmental Condition:	Temperature (°C) : 22.0 ; Relative Humidity (%RH) : 52.0		

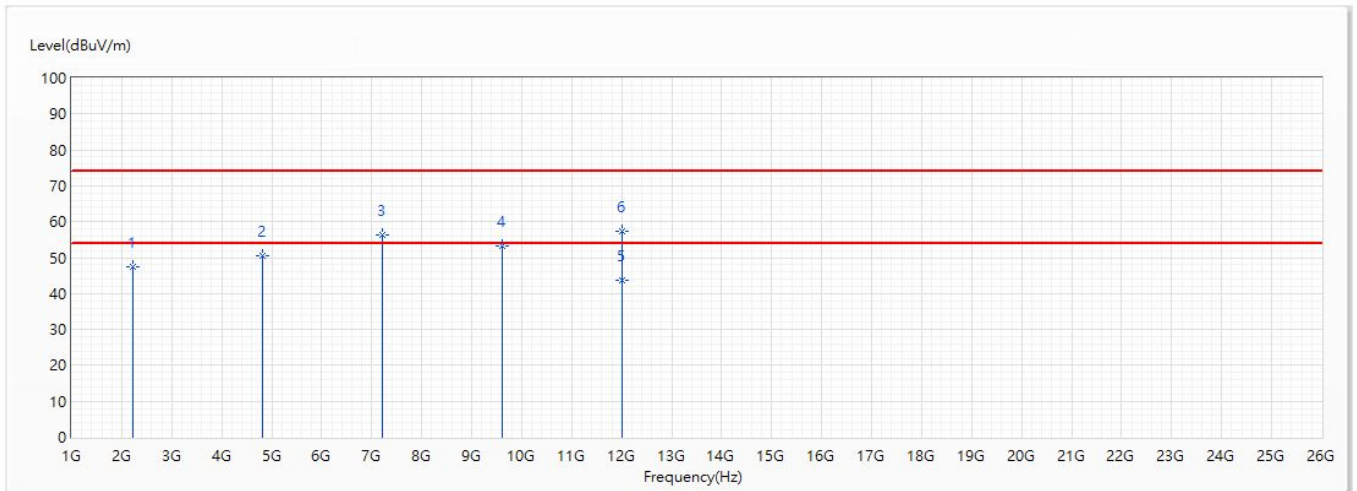

No	Frequency (MHz)	Emission Level (dBuV/m)	Limit (dBuV/m)	Margin (dB)	Reading Level (dBuV)	Correct Factor (dB/m)	Detector Type
1	2219.2	47.39	74.00	-26.61	54.93	-7.54	PK
2	4804	50.42	74.00	-23.58	47.43	2.99	PK
3	7206	56.18	74.00	-17.82	45.04	11.14	PK
4	9608	53.30	74.00	-20.70	36.79	16.51	PK
* 5	12010	43.85	54.00	-10.15	23.79	20.06	AV
6	12010	57.39	74.00	-16.61	37.33	20.06	PK

Note:

1. All reading above 1GHz is performed with peak and/or average measurements as necessary.
2. “ * ”, means this data is the worst emission level.
3. Emission Level = Reading Level + Correct Factor.
4. The average measurement was not performed when the peak measured data under the limit of average detection.
5. The Emission above 13GHz were not included is because their levels are too low.

Site :	CB4-H	Engineer :	Scott
Model No :	SUPER DRIVE, MEGA DRIVE	Test Date :	2019/12/16
Test Voltage :	AC 120V/60Hz	Polarity :	Vertical
Test Mode :	Mode 1 : Transmit Mode_Power by Adapter		
Note :	802.15.1_BLE_2402MHz		
Environmental Condition:	Temperature (°C) : 22.0 ; Relative Humidity (%RH) : 52.0		

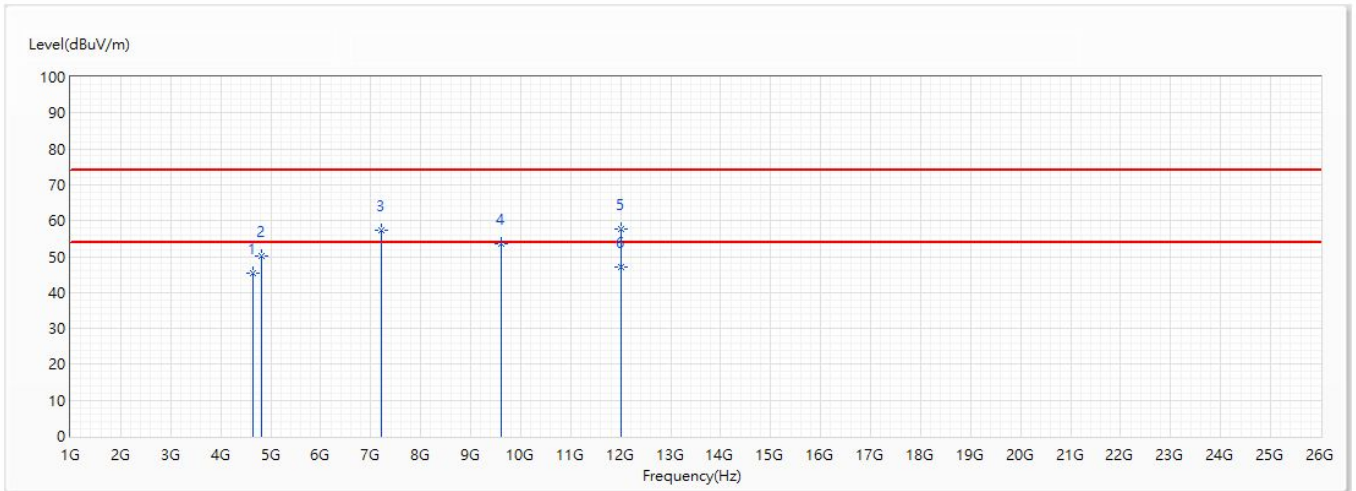

No	Frequency (MHz)	Emission Level (dBuV/m)	Limit (dBuV/m)	Margin (dB)	Reading Level (dBuV)	Correct Factor (dB/m)	Detector Type
1	4642.92	45.52	74.00	-28.48	43.34	2.18	PK
2	4804	50.15	74.00	-23.85	47.16	2.99	PK
3	7206	57.45	74.00	-16.55	46.31	11.14	PK
4	9608	53.65	74.00	-20.35	37.14	16.51	PK
5	12010	57.79	74.00	-16.21	37.73	20.06	PK
* 6	12010	47.14	54.00	-6.86	27.08	20.06	AV

Note:

1. All reading above 1GHz is performed with peak and/or average measurements as necessary.
2. “ * ”, means this data is the worst emission level.
3. Emission Level = Reading Level + Correct Factor.
4. The average measurement was not performed when the peak measured data under the limit of average detection.
5. The Emission above 13GHz were not included is because their levels are too low.

Site :	CB4-H	Engineer :	Scott
Model No :	SUPER DRIVE, MEGA DRIVE	Test Date :	2019/12/16
Test Voltage :	AC 120V/60Hz	Polarity :	Horizontal
Test Mode :	Mode 1 : Transmit Mode_Power by Adapter		
Note :	802.15.1_BLE_2440MHz		
Environmental Condition:	Temperature (°C) : 22.0 ; Relative Humidity (%RH) : 52.0		

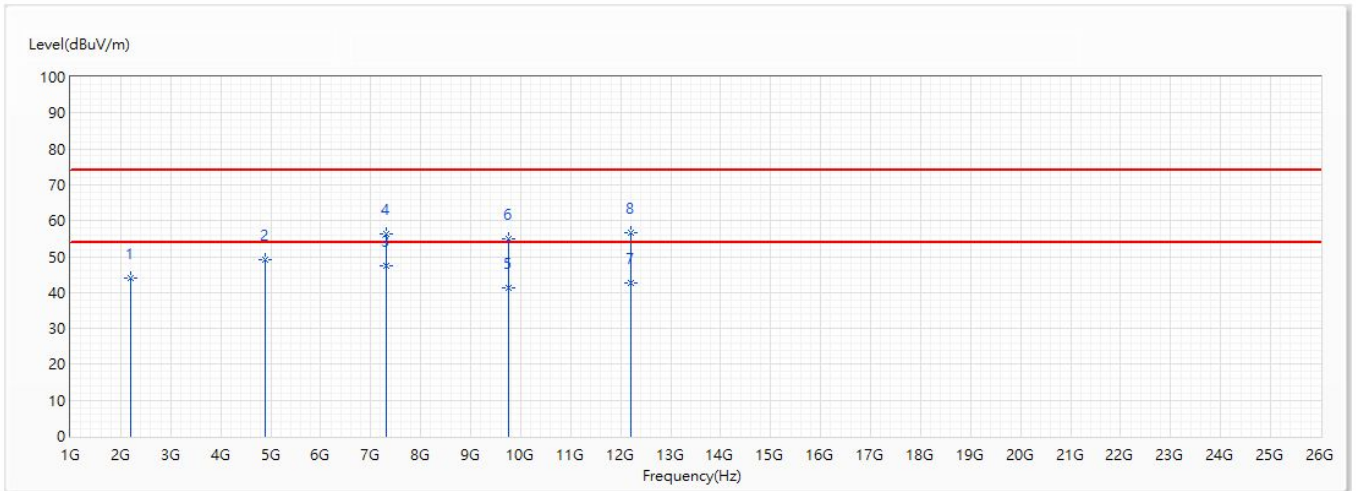

No	Frequency (MHz)	Emission Level (dBuV/m)	Limit (dBuV/m)	Margin (dB)	Reading Level (dBuV)	Correct Factor (dB/m)	Detector Type
1	2198.7	43.90	74.00	-30.10	51.53	-7.63	PK
2	4880	49.05	74.00	-24.95	45.67	3.38	PK
* 3	7320	47.33	54.00	-6.67	35.90	11.43	AV
4	7320	56.40	74.00	-17.60	44.97	11.43	PK
5	9760	41.15	54.00	-12.85	24.30	16.85	AV
6	9760	54.85	74.00	-19.15	38.00	16.85	PK
7	12200	42.79	54.00	-11.21	22.86	19.93	AV
8	12200	56.57	74.00	-17.43	36.64	19.93	PK

Note:

1. All reading above 1GHz is performed with peak and/or average measurements as necessary.
2. “ * ”, means this data is the worst emission level.
3. Emission Level = Reading Level + Correct Factor.
4. The average measurement was not performed when the peak measured data under the limit of average detection.
5. The Emission above 13GHz were not included is because their levels are too low.

Site :	CB4-H	Engineer :	Scott
Model No :	SUPER DRIVE, MEGA DRIVE	Test Date :	2019/12/16
Test Voltage :	AC 120V/60Hz	Polarity :	Vertical
Test Mode :	Mode 1 : Transmit Mode_Power by Adapter		
Note :	802.15.1_BLE_2440MHz		
Environmental Condition:	Temperature (°C) : 22.0 ; Relative Humidity (%RH) : 52.0		

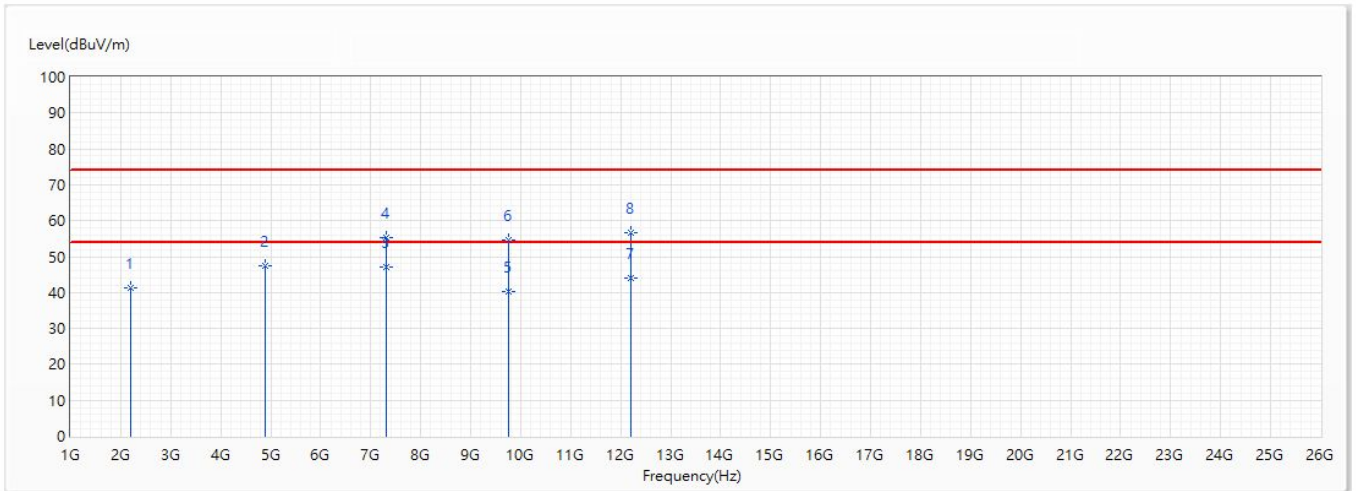

No	Frequency (MHz)	Emission Level (dBuV/m)	Limit (dBuV/m)	Margin (dB)	Reading Level (dBuV)	Correct Factor (dB/m)	Detector Type
1	2209.7	41.33	74.00	-32.67	48.92	-7.59	PK
2	4880	47.33	74.00	-26.67	43.95	3.38	PK
* 3	7320	46.93	54.00	-7.07	35.50	11.43	AV
4	7320	55.46	74.00	-18.54	44.03	11.43	PK
5	9760	40.25	54.00	-13.75	23.40	16.85	AV
6	9760	54.59	74.00	-19.41	37.74	16.85	PK
7	12200	44.05	54.00	-9.95	24.12	19.93	AV
8	12200	56.67	74.00	-17.33	36.74	19.93	PK

Note:

1. All reading above 1GHz is performed with peak and/or average measurements as necessary.
2. “ * ”, means this data is the worst emission level.
3. Emission Level = Reading Level + Correct Factor.
4. The average measurement was not performed when the peak measured data under the limit of average detection.
5. The Emission above 13GHz were not included is because their levels are too low.

Site :	CB4-H	Engineer :	Scott
Model No :	SUPER DRIVE, MEGA DRIVE	Test Date :	2019/12/16
Test Voltage :	AC 120V/60Hz	Polarity :	Horizontal
Test Mode :	Mode 1 : Transmit Mode_Power by Adapter		
Note :	802.15.1_BLE_2480MHz		
Environmental Condition:	Temperature (°C) : 22.0 ; Relative Humidity (%RH) : 52.0		

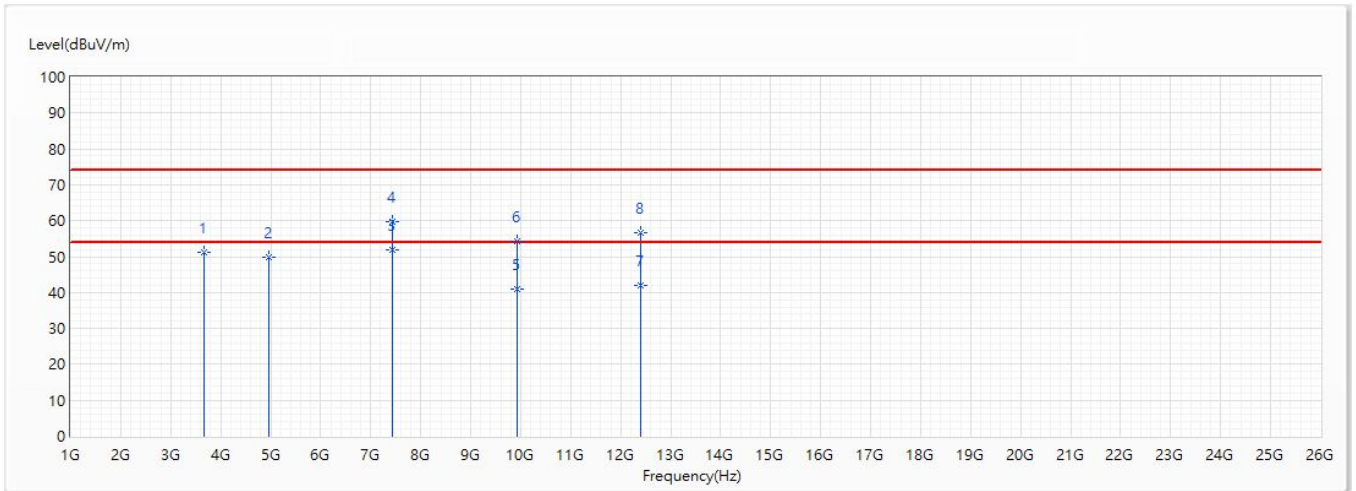

No	Frequency (MHz)	Emission Level (dBuV/m)	Limit (dBuV/m)	Margin (dB)	Reading Level (dBuV)	Correct Factor (dB/m)	Detector Type
1	3673	51.19	74.00	-22.81	53.27	-2.08	PK
2	4960	49.79	74.00	-24.21	46.02	3.77	PK
* 3	7440	51.85	54.00	-2.15	40.13	11.72	AV
4	7440	59.61	74.00	-14.39	47.89	11.72	PK
5	9920	40.85	54.00	-13.15	23.67	17.18	AV
6	9920	54.14	74.00	-19.86	36.96	17.18	PK
7	12400	41.91	54.00	-12.09	22.10	19.81	AV
8	12400	56.50	74.00	-17.50	36.69	19.81	PK

Note:

1. All reading above 1GHz is performed with peak and/or average measurements as necessary.
2. “ * ”, means this data is the worst emission level.
3. Emission Level = Reading Level + Correct Factor.
4. The average measurement was not performed when the peak measured data under the limit of average detection.
5. The Emission above 13GHz were not included is because their levels are too low.

Site :	CB4-H	Engineer :	Scott
Model No :	SUPER DRIVE, MEGA DRIVE	Test Date :	2019/12/16
Test Voltage :	AC 120V/60Hz	Polarity :	Vertical
Test Mode :	Mode 1 : Transmit Mode_Power by Adapter		
Note :	802.15.1_BLE_2480MHz		
Environmental Condition:	Temperature (°C) : 22.0 ; Relative Humidity (%RH) : 52.0		

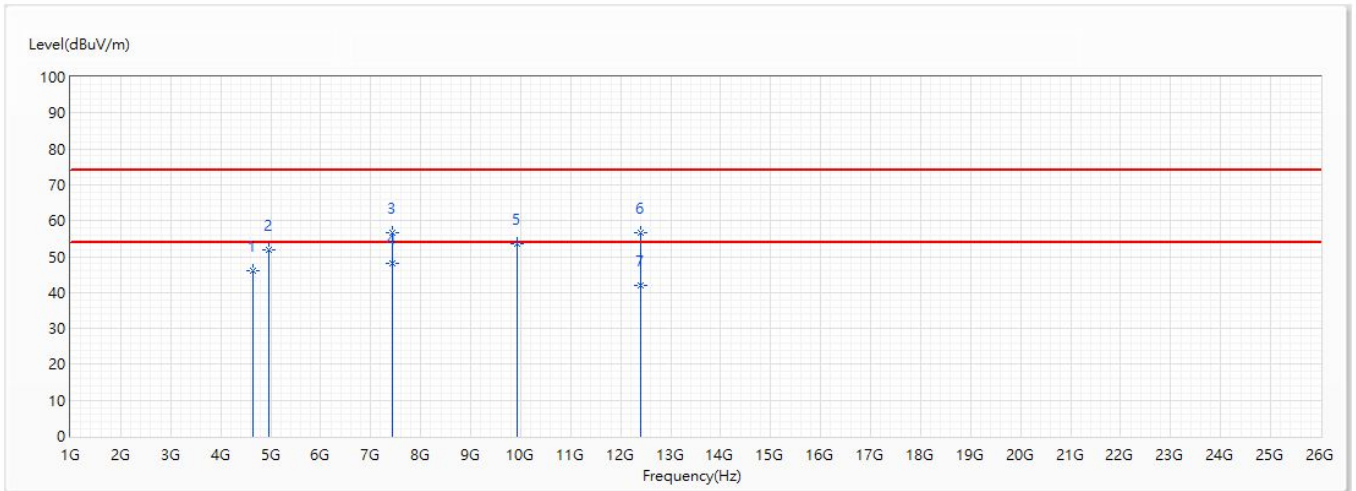

No	Frequency (MHz)	Emission Level (dBuV/m)	Limit (dBuV/m)	Margin (dB)	Reading Level (dBuV)	Correct Factor (dB/m)	Detector Type
1	4642.92	46.16	74.00	-27.84	43.98	2.18	PK
2	4960	51.76	74.00	-22.24	47.99	3.77	PK
3	7440	56.59	74.00	-17.41	44.87	11.72	PK
* 4	7440	48.17	54.00	-5.83	36.45	11.72	AV
5	9920	53.71	74.00	-20.29	36.53	17.18	PK
6	12400	56.53	74.00	-17.47	36.72	19.81	PK
7	12400	41.81	54.00	-12.19	22.00	19.81	AV

Note:

1. All reading above 1GHz is performed with peak and/or average measurements as necessary.
2. “ * ”, means this data is the worst emission level.
3. Emission Level = Reading Level + Correct Factor.
4. The average measurement was not performed when the peak measured data under the limit of average detection.
5. The Emission above 13GHz were not included is because their levels are too low.

5. RF antenna conducted test

5.1. Test Setup

RF Conducted Measurement:

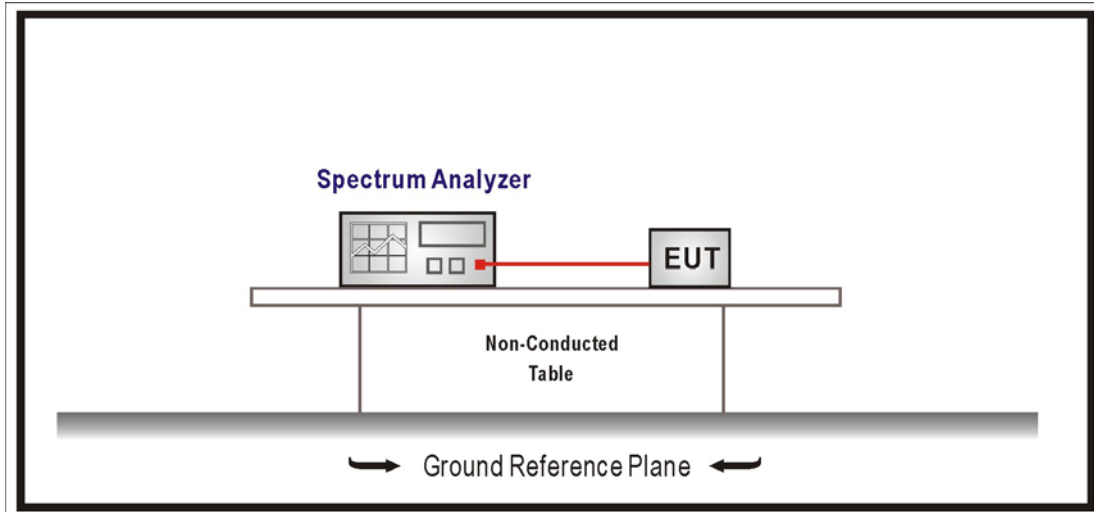

5.2. Limits

In any 100 kHz bandwidth outside the frequency band in which the spread spectrum or digitally modulated intentional radiator is operating, the radio frequency power that is produced by the intentional radiator shall be at least 20 dB below that in the 100 kHz bandwidth within the band that contains the highest level of the desired power, based on either an RF conducted or a radiated measurement, provided the transmitter demonstrates compliance with the peak conducted power limits. If the transmitter complies with the conducted power limits based on the use of RMS averaging over a time interval, the attenuation required under this paragraph shall be 30 dB instead of 20 dB. Attenuation below the general limits specified in §15.209(a) is not required. In addition, radiated emissions which fall in the restricted bands, as defined in §15.205(a), must also comply with the radiated emission limits specified in §15.209(a) (see §15.205(c)).

5.3. Test Procedure

The EUT was setup according to ANSI C63.10: 2013 and tested according to DTS test procedure of KDB558074 V05 r02 for compliance to FCC 47CFR 15.247 requirements. Set RBW = 100 kHz, Set VBW > RBW, scan up through 10th harmonic.

5.4. Test Specification

According to FCC Part 15 Subpart C Paragraph 15.247 and ISSED RSS-247.

5.5. Test Result

Product	Bicycle Light		
Test Item	RF antenna conducted test		
Test Mode	Mode 1 : Transmit Mode_Power by Adapter		
Date of Test	2019/12/25	Test Site	SR12-H
Temperature (°C)	21.5	Humidity (%RH)	55.0

Channel	Frequency (MHz)	Measure Level (dBc)	Limit (dBc)
00	2402	51.695	≥20
19	2440	54.888	≥20
39	2480	53.590	≥20

Channel 00

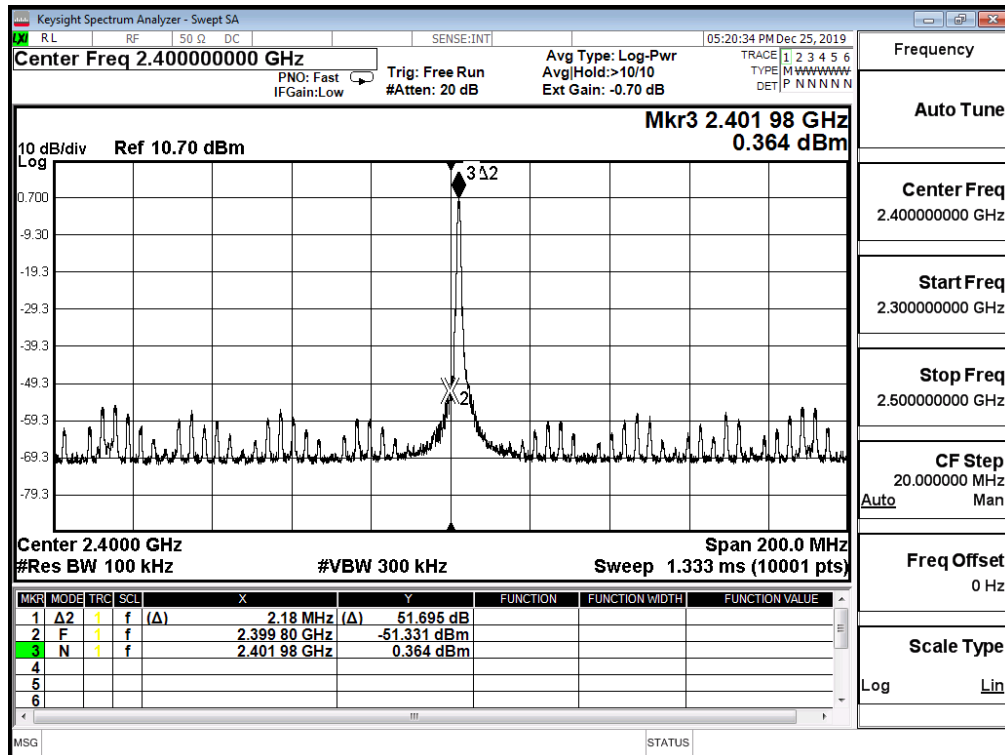

Channel 19

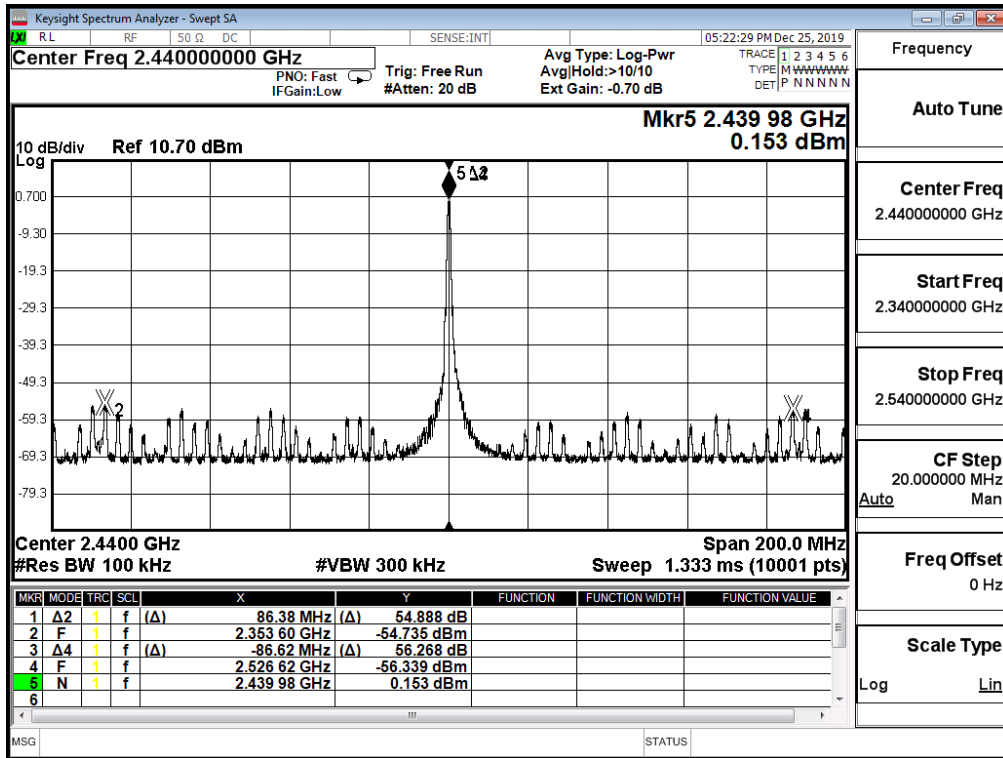

Channel 39

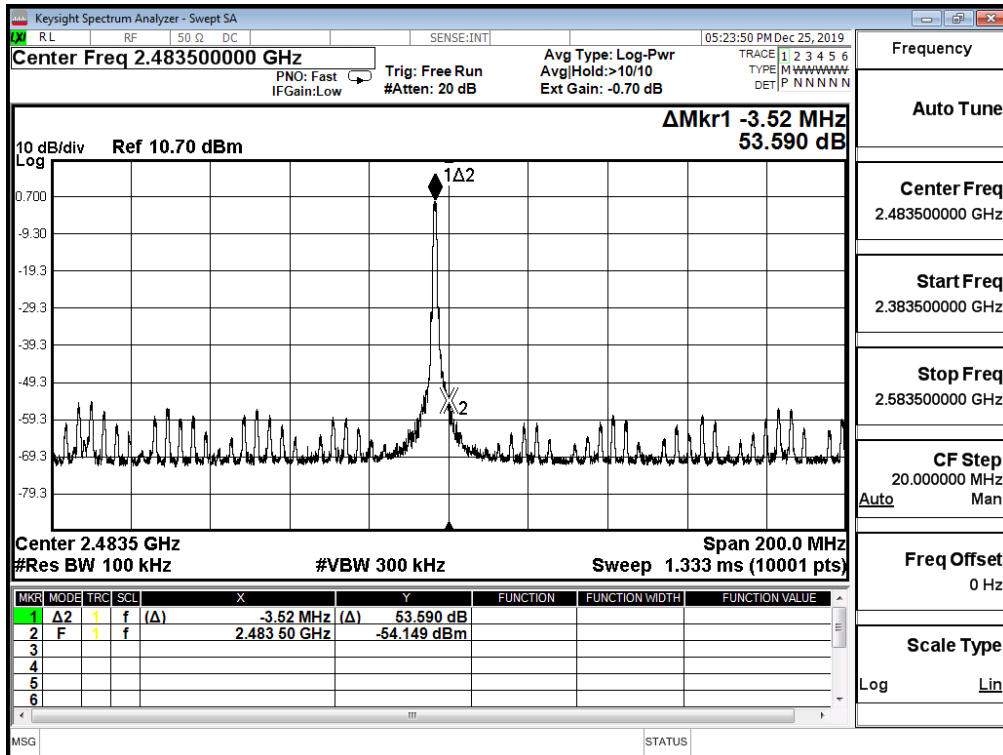

Product	Bicycle Light		
Test Item	RF antenna conducted test		
Test Mode	Mode 1 : Transmit Mode_Power by Adapter		
Date of Test	2019/12/25	Test Site	SR12-H
Temperature (°C)	21.5	Humidity (%RH)	55.0

Channel 00 (30MHz-25GHz)

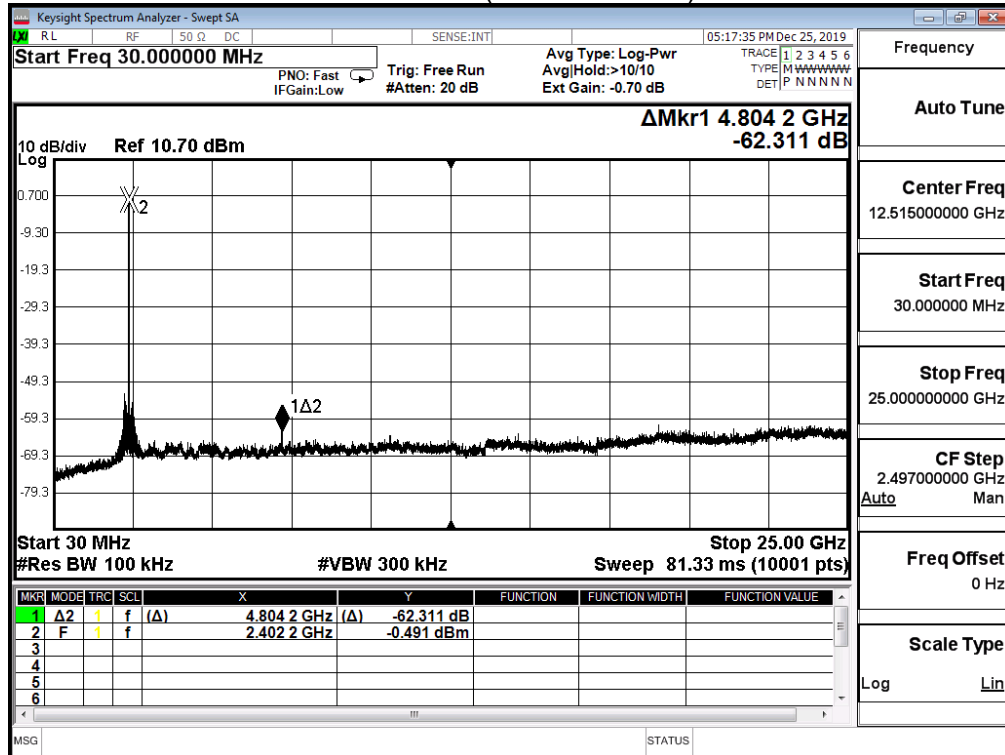

Channel 19 (30MHz-25GHz)

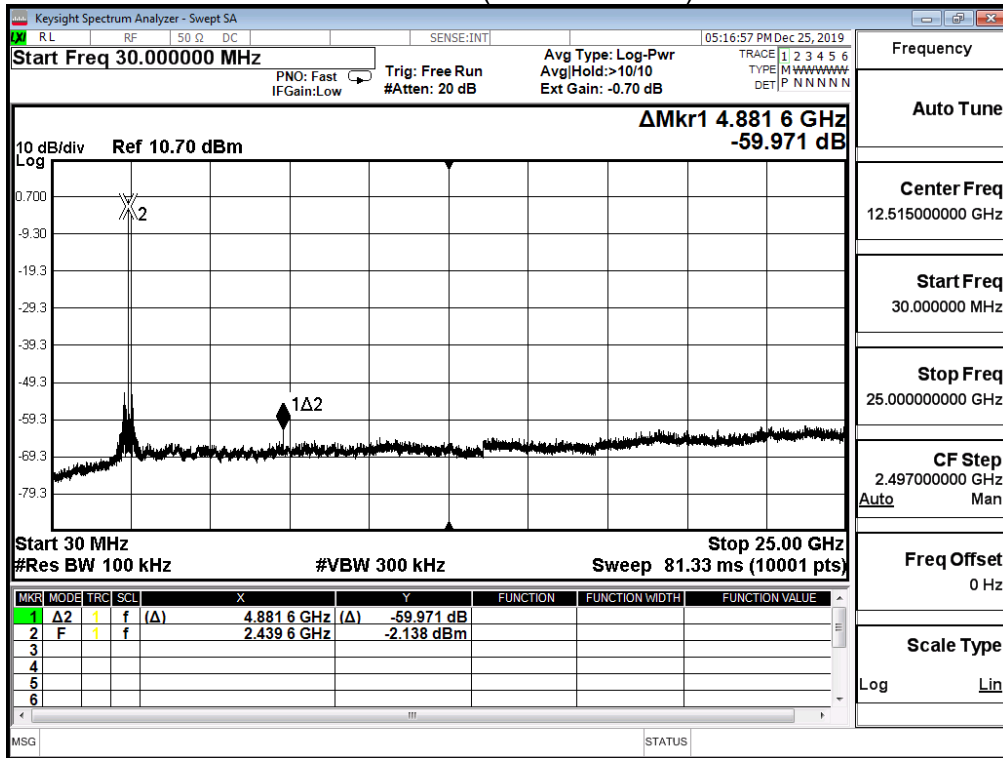

Channel 39 (30MHz-25GHz)

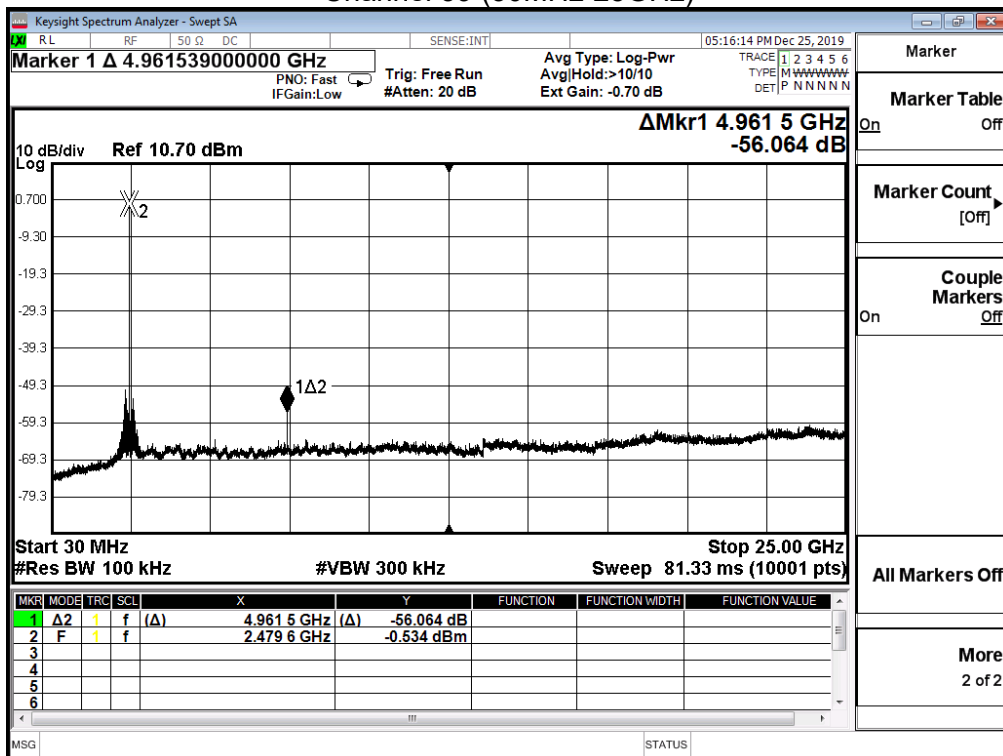

6. Radiated Emission Band Edge

6.1. Test Setup

RF Radiated Measurement:

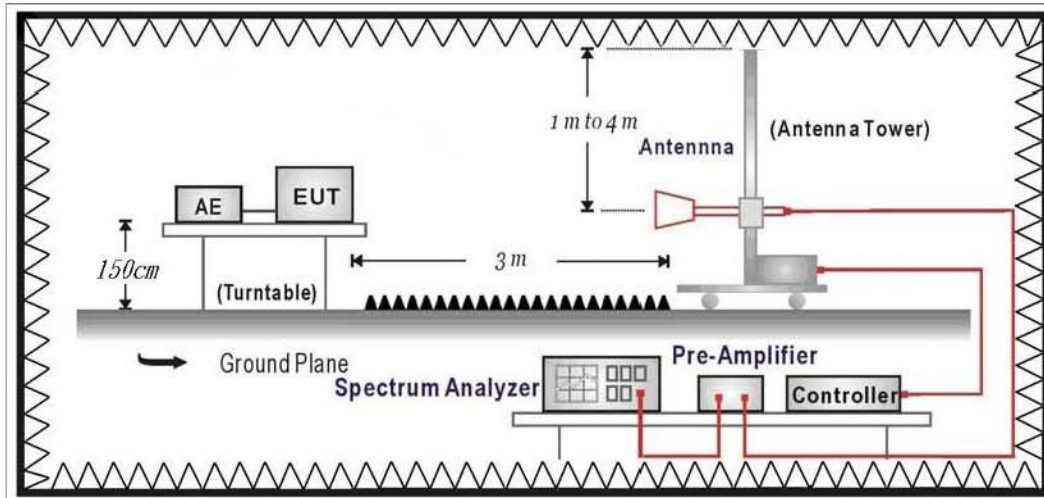

6.2. Limits

Emissions radiated outside of the specified frequency bands, except for harmonics, shall be attenuated by at least 20dB below the level of the fundamental or to the general radiated emission limits in paragraph 15.209, whichever is the lesser attenuation.

6.3. Test Procedure

The EUT was setup according to ANSI C63.10: 2013 and tested according to DTS test procedure of KDB558074 V05 r02 for compliance to FCC 47CFR 15.247 requirements. The EUT and its simulators are placed on a turn table which is 0.8 meter above ground. The turn table can rotate 360 degrees to determine the position of the maximum emission level. The EUT was positioned such that the distance from antenna to the EUT was 3 meters.

The antenna can move up and down between 1 meter and 4 meters to find out the maximum emission level.

Both horizontal and vertical polarization of the antenna are set on measurement. In order to find the maximum emission, all of the interface cables must be manipulated according to ANSI C63.10: 2013 on radiated measurement.

6.4. Test Specification

According to FCC Part 15 Subpart C Paragraph 15.247 and ISSED RSS-247.

6.5. Test Result

Site :	CB4-H	Engineer :	Scott
Model No :	SUPER DRIVE, MEGA DRIVE	Test Date :	2019/12/2
Test Voltage :	AC 120V/60Hz	Polarity :	Horizontal
Test Mode :	Mode 1 : Transmit Mode_Power by Adapter		
Note :	802.15.1_BLE_2402MHz		
Environmental Condition:	Temperature (°C) : 23.0 ; Relative Humidity (%RH) : 53.0		

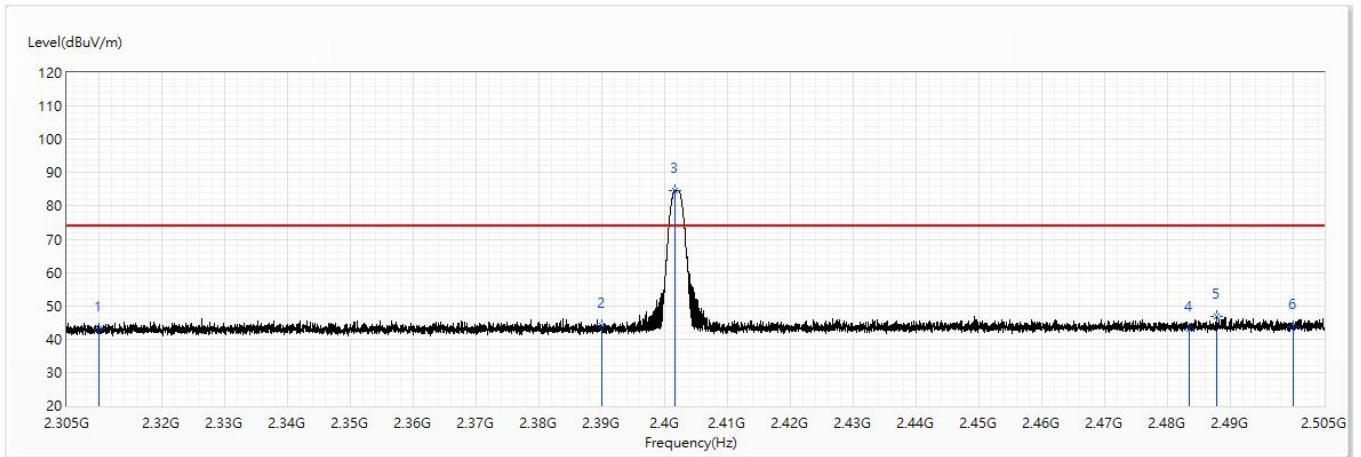

No	Frequency (MHz)	Emission Level (dBuV/m)	Limit (dBuV/m)	Margin (dB)	Reading Level (dBuV)	Correct Factor (dB/m)	Detector Type
1	2310	43.05	74.00	-30.95	29.32	13.73	PK
2	2390	44.08	74.00	-29.92	29.91	14.17	PK
! 3	2401.725	84.68	74.00	10.68	70.46	14.22	PK
4	2483.5	43.07	74.00	-30.93	28.41	14.66	PK
5	2487.925	46.97	74.00	-27.03	32.29	14.68	PK
6	2500	43.55	74.00	-30.45	28.80	14.75	PK

Note:

1. All reading above 1GHz is performed with peak and/or average measurements as necessary.
2. “ * ”, means this data is the worst emission level.
3. Emission Level = Reading Level + Correct Factor.
4. The average measurement was not performed when the peak measured data under the limit of average detection. If the readings given are average, peak measurement should also be supplied.
5. The fundamental for reference only, it’s not restricted by unwanted emission limit.

Site :	CB4-H	Engineer :	Scott
Model No :	SUPER DRIVE, MEGA DRIVE	Test Date :	2019/12/2
Test Voltage :	AC 120V/60Hz	Polarity :	Vertical
Test Mode :	Mode 1 : Transmit Mode_Power by Adapter		
Note :	802.15.1_BLE_2402MHz		
Environmental Condition:	Temperature (°C) : 23.0 ; Relative Humidity (%RH) : 53.0		

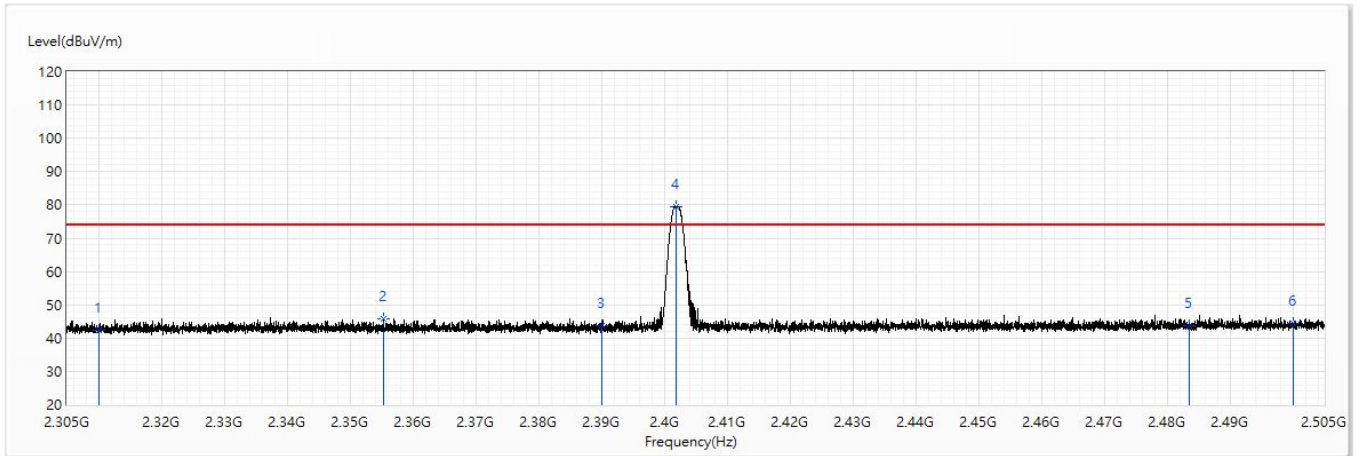

No	Frequency (MHz)	Emission Level (dBuV/m)	Limit (dBuV/m)	Margin (dB)	Reading Level (dBuV)	Correct Factor (dB/m)	Detector Type
1	2310	42.42	74.00	-31.58	28.69	13.73	PK
2	2355.3	45.89	74.00	-28.11	31.91	13.98	PK
3	2390	43.67	74.00	-30.33	29.50	14.17	PK
! 4	2401.95	79.42	74.00	5.42	65.20	14.22	PK
5	2483.5	43.84	74.00	-30.16	29.18	14.66	PK
6	2500	44.32	74.00	-29.68	29.57	14.75	PK

Note:

1. All reading above 1GHz is performed with peak and/or average measurements as necessary.
2. “ * ”, means this data is the worst emission level.
3. Emission Level = Reading Level + Correct Factor.
4. The average measurement was not performed when the peak measured data under the limit of average detection. If the readings given are average, peak measurement should also be supplied.
5. The fundamental for reference only, it's not restricted by unwanted emission limit.

Site :	CB4-H	Engineer :	Scott
Model No :	SUPER DRIVE, MEGA DRIVE	Test Date :	2019/12/2
Test Voltage :	AC 120V/60Hz	Polarity :	Horizontal
Test Mode :	Mode 1 : Transmit Mode_Power by Adapter		
Note :	802.15.1_BLE_2440MHz		
Environmental Condition:	Temperature (°C) : 23.0 ; Relative Humidity (%RH) : 53.0		

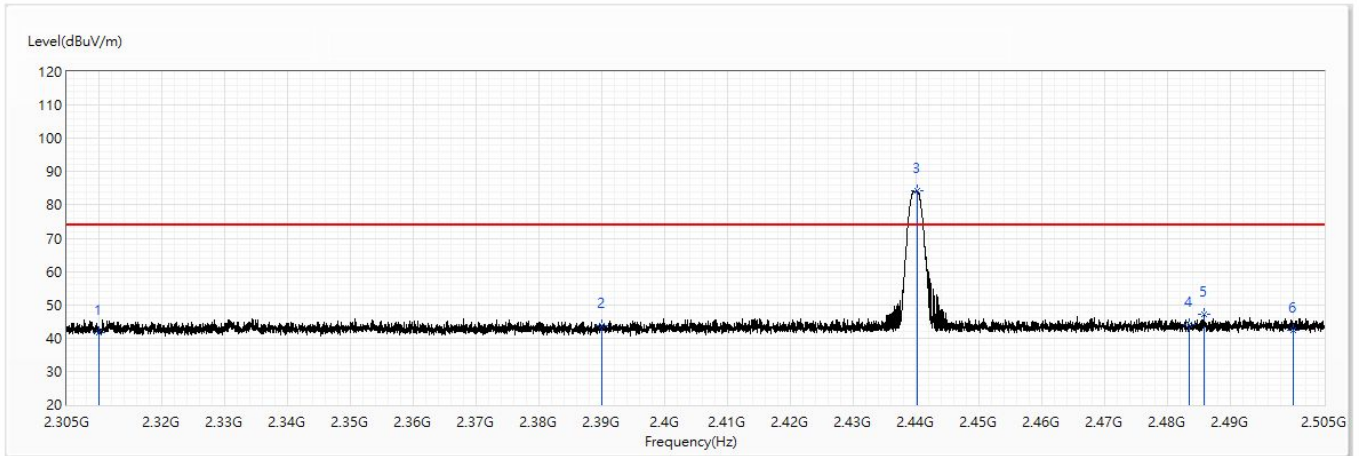

No	Frequency (MHz)	Emission Level (dBuV/m)	Limit (dBuV/m)	Margin (dB)	Reading Level (dBuV)	Correct Factor (dB/m)	Detector Type
1	2310	41.63	74.00	-32.37	27.90	13.73	PK
2	2390	43.71	74.00	-30.29	29.54	14.17	PK
! 3	2440.225	84.14	74.00	10.14	69.71	14.43	PK
4	2483.5	44.16	74.00	-29.84	29.50	14.66	PK
5	2485.95	47.07	74.00	-26.93	32.39	14.68	PK
6	2500	42.39	74.00	-31.61	27.64	14.75	PK

Note:

1. All reading above 1GHz is performed with peak and/or average measurements as necessary.
2. “ * ”, means this data is the worst emission level.
3. Emission Level = Reading Level + Correct Factor.
4. The average measurement was not performed when the peak measured data under the limit of average detection. If the readings given are average, peak measurement should also be supplied.
5. The fundamental for reference only, it's not restricted by unwanted emission limit.

Site :	CB4-H	Engineer :	Scott
Model No :	SUPER DRIVE, MEGA DRIVE	Test Date :	2019/12/2
Test Voltage :	AC 120V/60Hz	Polarity :	Vertical
Test Mode :	Mode 1 : Transmit Mode_Power by Adapter		
Note :	802.15.1_BLE_2440MHz		
Environmental Condition:	Temperature (°C) : 23.0 ; Relative Humidity (%RH) : 53.0		

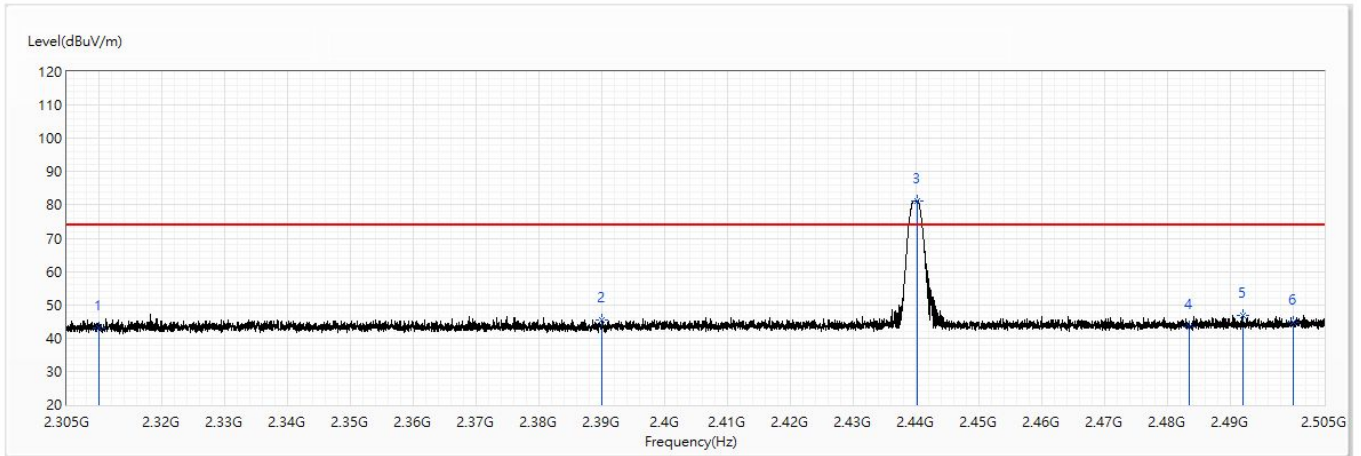

No	Frequency (MHz)	Emission Level (dBuV/m)	Limit (dBuV/m)	Margin (dB)	Reading Level (dBuV)	Correct Factor (dB/m)	Detector Type
1	2310	43.07	74.00	-30.93	29.34	13.73	PK
2	2390	45.42	74.00	-28.58	31.25	14.17	PK
! 3	2440.3	81.25	74.00	7.25	66.82	14.43	PK
4	2483.5	43.39	74.00	-30.61	28.73	14.66	PK
5	2492.1	46.91	74.00	-27.09	32.20	14.71	PK
6	2500	44.68	74.00	-29.32	29.93	14.75	PK

Note:

1. All reading above 1GHz is performed with peak and/or average measurements as necessary.
2. “ * ”, means this data is the worst emission level.
3. Emission Level = Reading Level + Correct Factor.
4. The average measurement was not performed when the peak measured data under the limit of average detection. If the readings given are average, peak measurement should also be supplied.
5. The fundamental for reference only, it's not restricted by unwanted emission limit.

Site :	CB4-H	Engineer :	Scott
Model No :	SUPER DRIVE, MEGA DRIVE	Test Date :	2019/12/2
Test Voltage :	AC 120V/60Hz	Polarity :	Horizontal
Test Mode :	Mode 1 : Transmit Mode_Power by Adapter		
Note :	802.15.1_BLE_2480MHz		
Environmental Condition:	Temperature (°C) : 23.0 ; Relative Humidity (%RH) : 53.0		

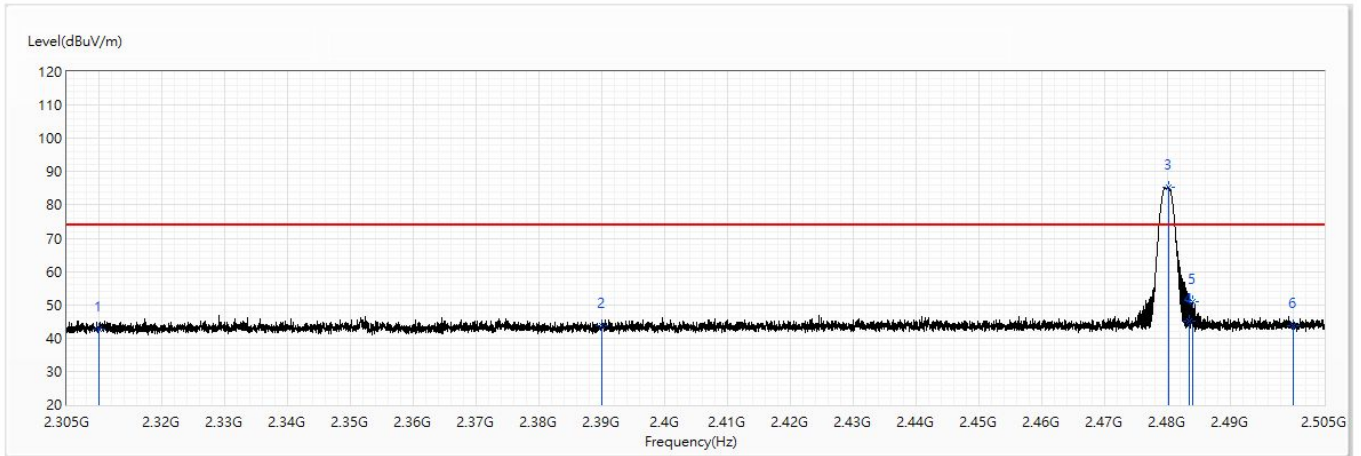

No	Frequency (MHz)	Emission Level (dBuV/m)	Limit (dBuV/m)	Margin (dB)	Reading Level (dBuV)	Correct Factor (dB/m)	Detector Type
1	2310	42.67	74.00	-31.33	28.94	13.73	PK
2	2390	43.60	74.00	-30.40	29.43	14.17	PK
! 3	2480.275	85.19	74.00	11.19	70.55	14.64	PK
4	2483.5	44.92	74.00	-29.08	30.26	14.66	PK
5	2484.05	50.85	74.00	-23.15	36.19	14.66	PK
6	2500	43.87	74.00	-30.13	29.12	14.75	PK

Note:

1. All reading above 1GHz is performed with peak and/or average measurements as necessary.
2. “ * ”, means this data is the worst emission level.
3. Emission Level = Reading Level + Correct Factor.
4. The average measurement was not performed when the peak measured data under the limit of average detection. If the readings given are average, peak measurement should also be supplied.
5. The fundamental for reference only, it's not restricted by unwanted emission limit.

Site :	CB4-H	Engineer :	Scott
Model No :	SUPER DRIVE, MEGA DRIVE	Test Date :	2019/12/2
Test Voltage :	AC 120V/60Hz	Polarity :	Vertical
Test Mode :	Mode 1 : Transmit Mode_Power by Adapter		
Note :	802.15.1_BLE_2480MHz		
Environmental Condition:	Temperature (°C) : 23.0 ; Relative Humidity (%RH) : 53.0		

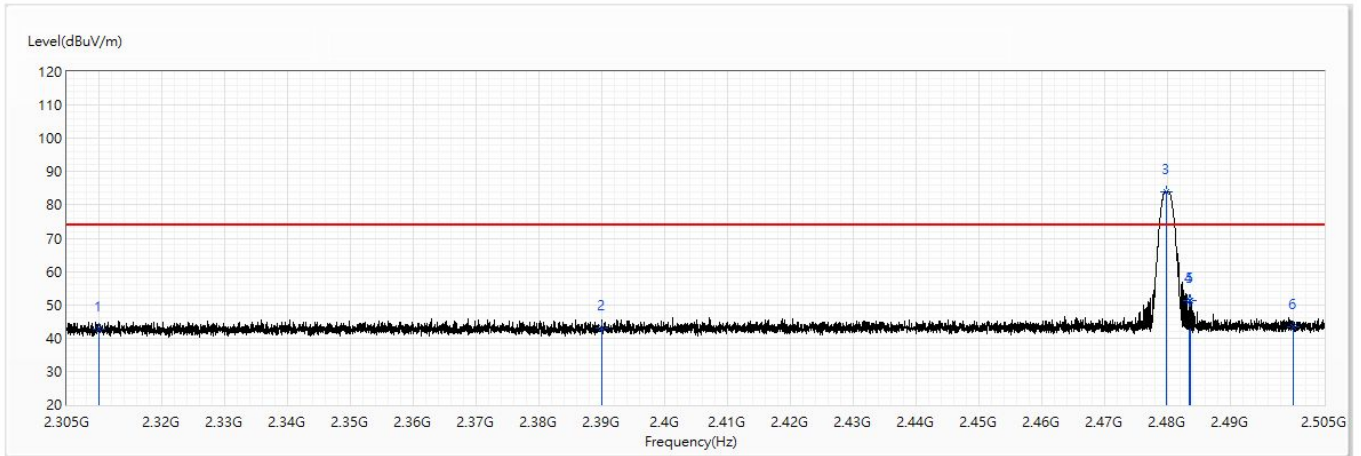

No	Frequency (MHz)	Emission Level (dBuV/m)	Limit (dBuV/m)	Margin (dB)	Reading Level (dBuV)	Correct Factor (dB/m)	Detector Type
1	2310	42.60	74.00	-31.40	28.87	13.73	PK
2	2390	42.97	74.00	-31.03	28.80	14.17	PK
! 3	2479.975	83.97	74.00	9.97	69.33	14.64	PK
4	2483.5	51.24	74.00	-22.76	36.58	14.66	PK
5	2483.775	51.36	74.00	-22.64	36.70	14.66	PK
6	2500	43.49	74.00	-30.51	28.74	14.75	PK

Note:

1. All reading above 1GHz is performed with peak and/or average measurements as necessary.
2. “ * ”, means this data is the worst emission level.
3. Emission Level = Reading Level + Correct Factor.
4. The average measurement was not performed when the peak measured data under the limit of average detection. If the readings given are average, peak measurement should also be supplied.
5. The fundamental for reference only, it's not restricted by unwanted emission limit.

7. Occupied Bandwidth & DTS Bandwidth

7.1. Test Setup

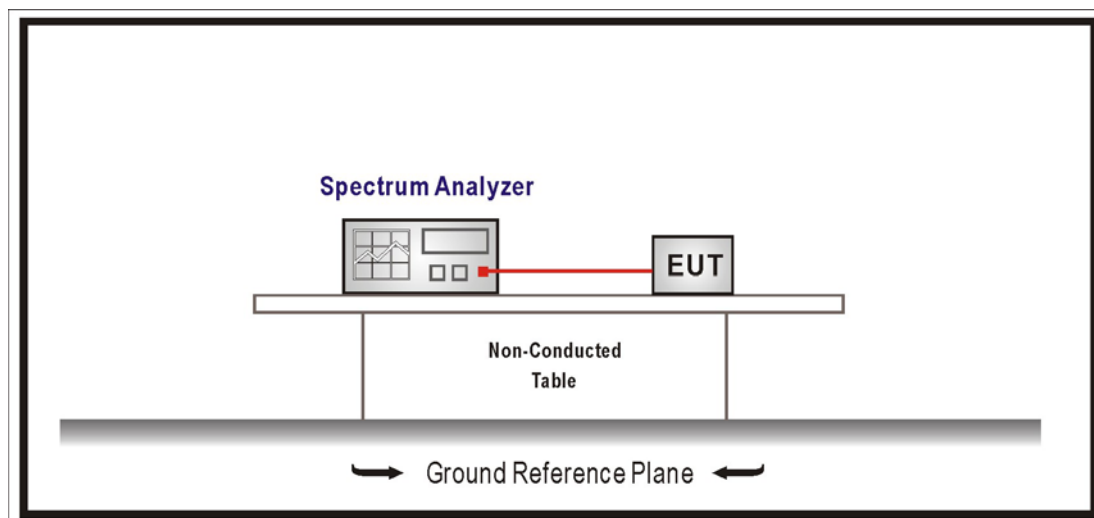

7.2. Limits

The 6 dB bandwidth: ≥ 500 kHz.

Occupied Bandwidth: NA

7.3. Test Procedures

The EUT was setup according to ANSI C63.10: 2013; tested according to DTS test procedure of KDB558074 V05 r02 for compliance to FCC 47CFR 15.247 requirements.

7.4. Test Specification

According to FCC Part 15 Subpart C Paragraph 15.247 and ISED RSS-247.

7.5. Test Result

Product	Bicycle Light		
Test Item	Occupied Bandwidth		
Test Mode	Mode 1 : Transmit Mode_Power by Adapter		
Date of Test	2019/12/25	Test Site	SR12-H
Temperature (°C)	21.5	Humidity (%RH)	55.0

Channel No.	Frequency (MHz)	Measure Level (MHz)	Limit (MHz)
00	2402	1.044	--
19	2440	1.045	--
39	2480	1.047	--

Channel 00

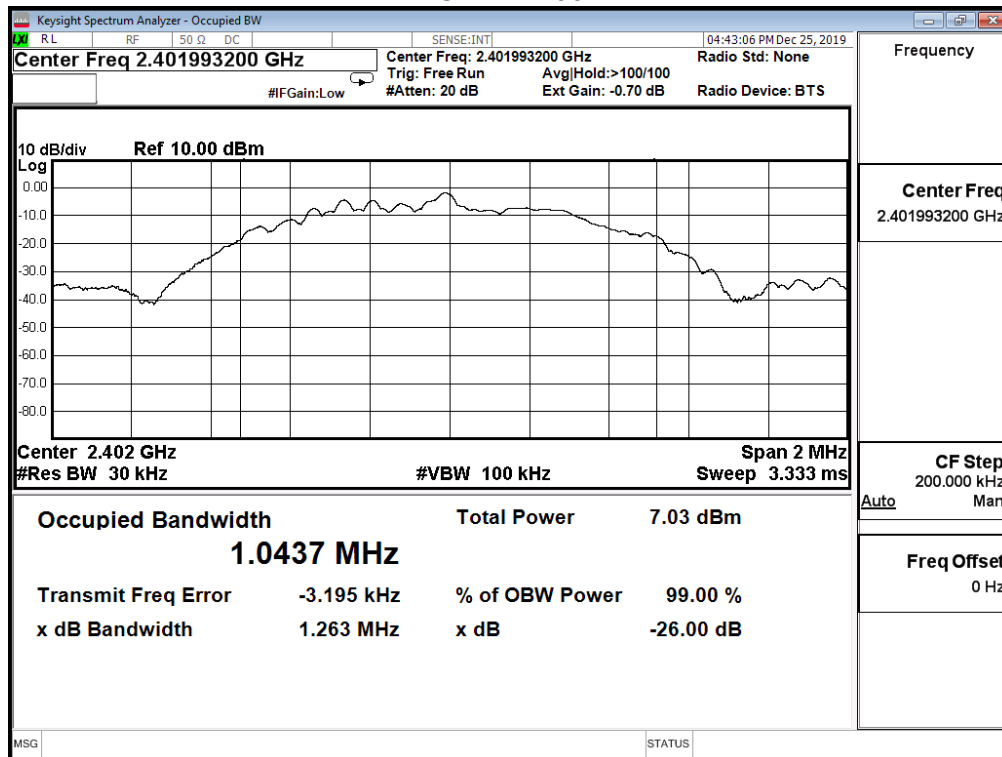

Channel 19

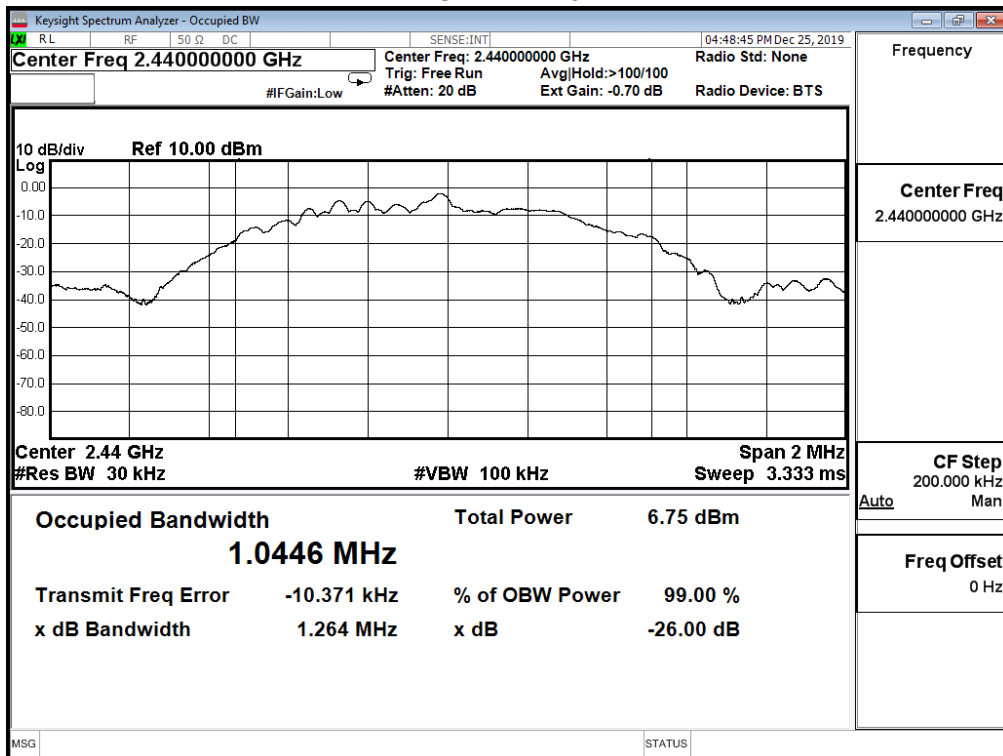

Channel 39

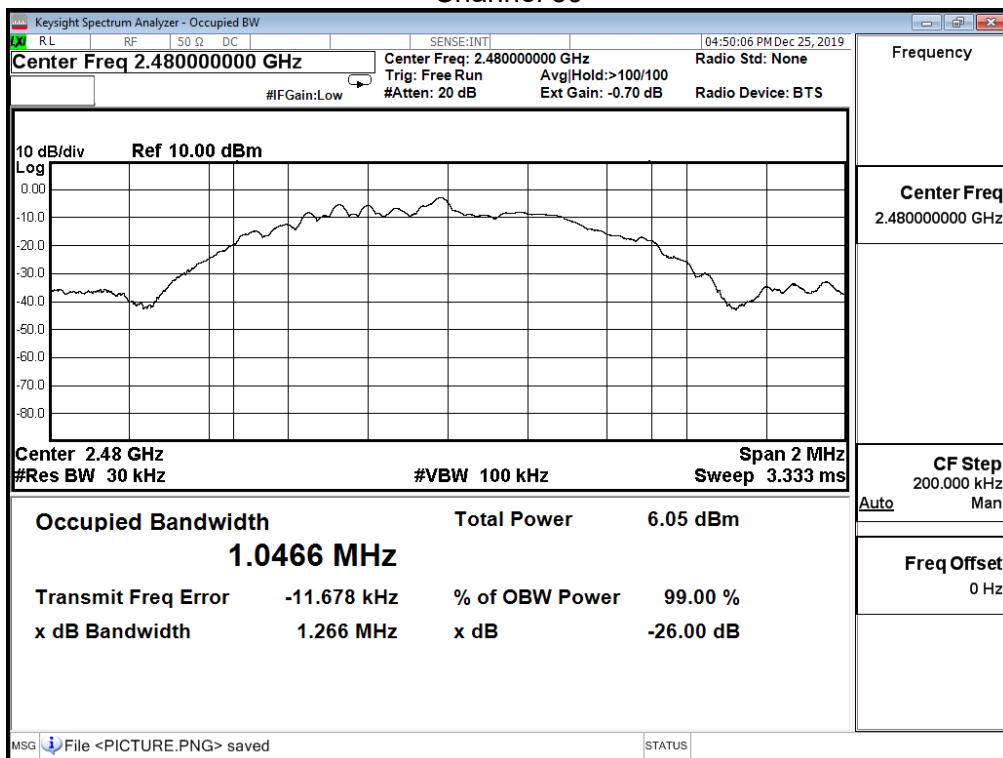

Product	Bicycle Light		
Test Item	DTS Bandwidth		
Test Mode	Mode 1 : Transmit Mode_Power by Adapter		
Date of Test	2019/12/25	Test Site	SR12-H
Temperature (°C)	21.5	Humidity (%RH)	55.0

Channel No.	Frequency (MHz)	Measure Value (MHz)	Limit (MHz)
00	2402	0.721	≥0.500
19	2440	0.719	≥0.500
39	2480	0.714	≥0.500

Channel 00

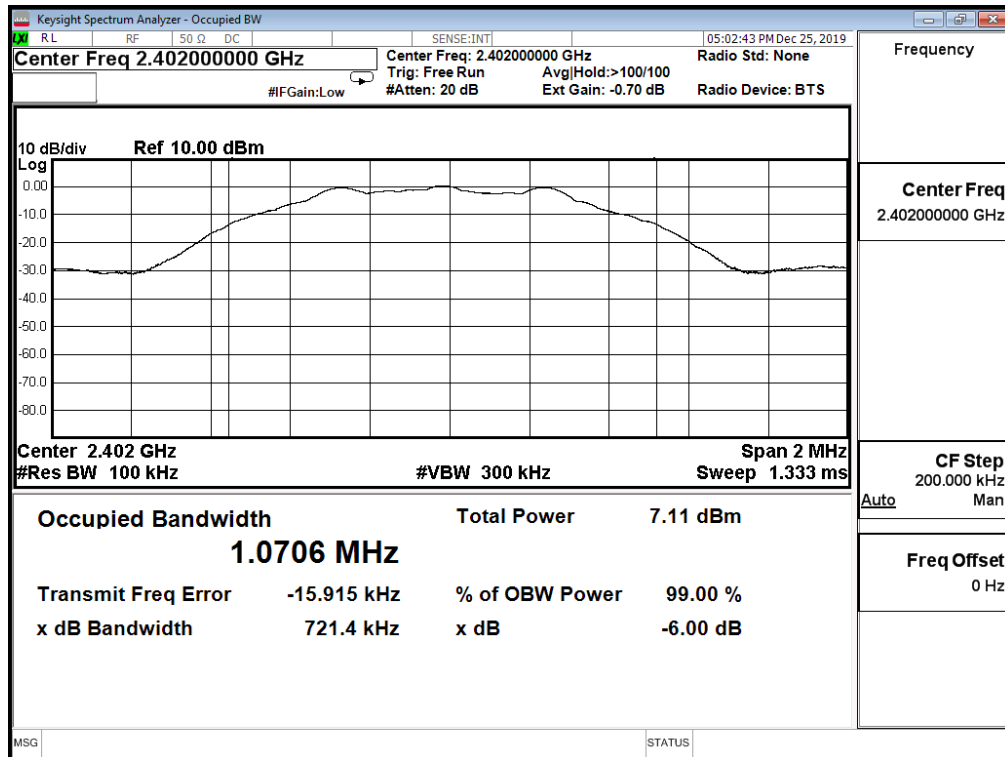

Channel 19

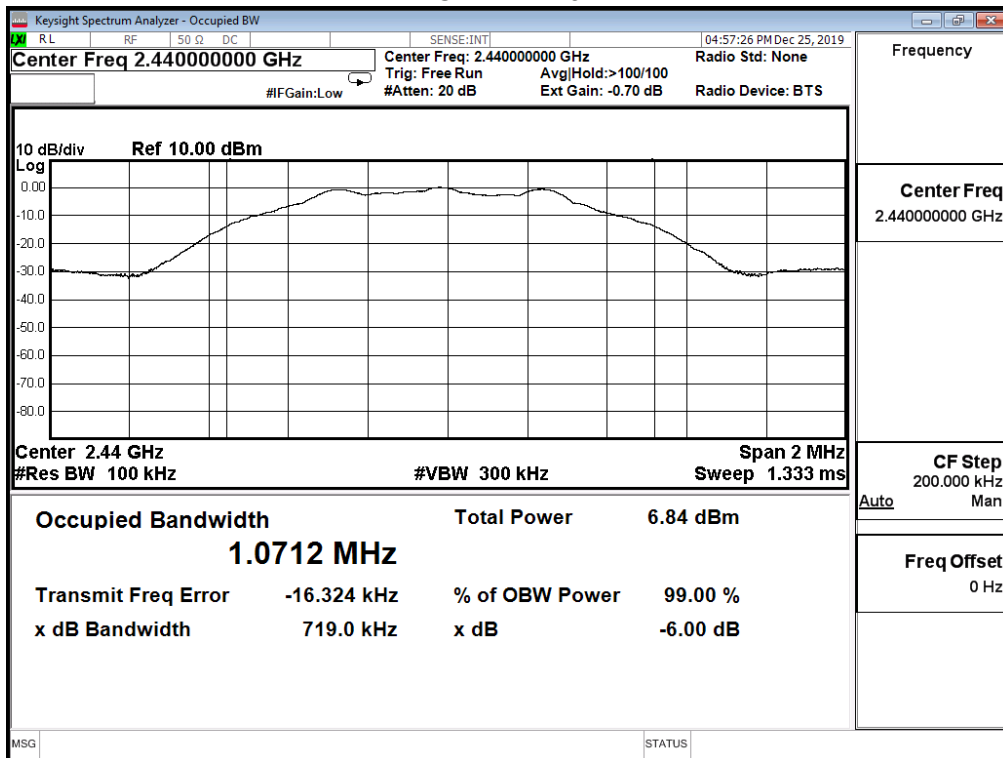

Channel 39

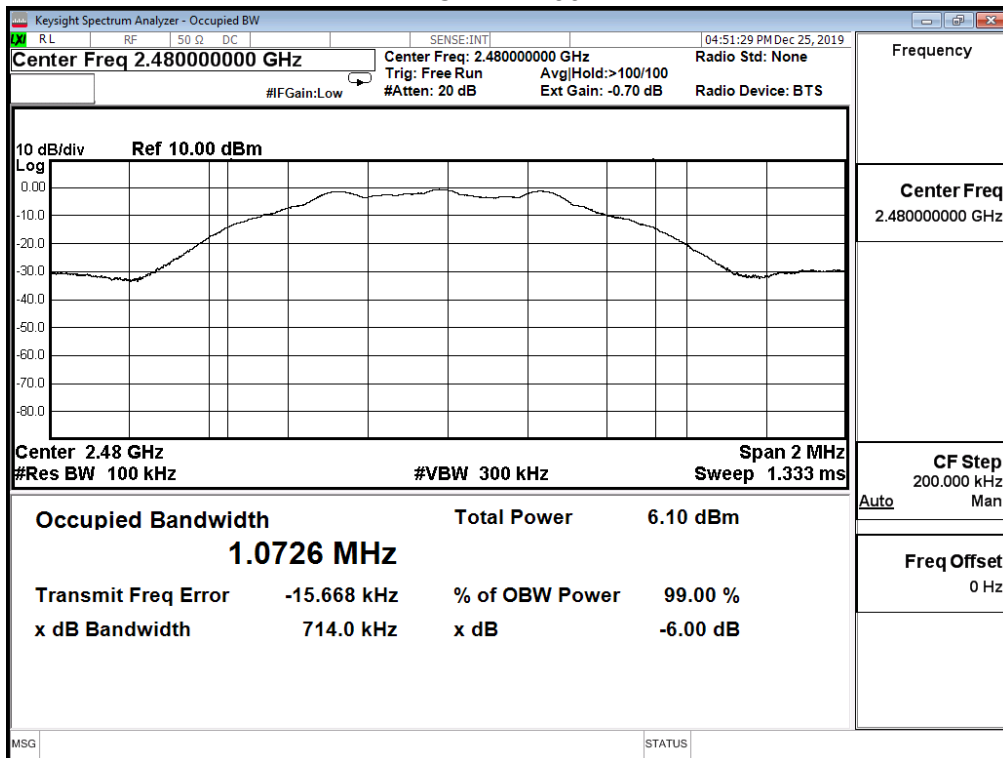

8. Power Density

8.1. Test Setup

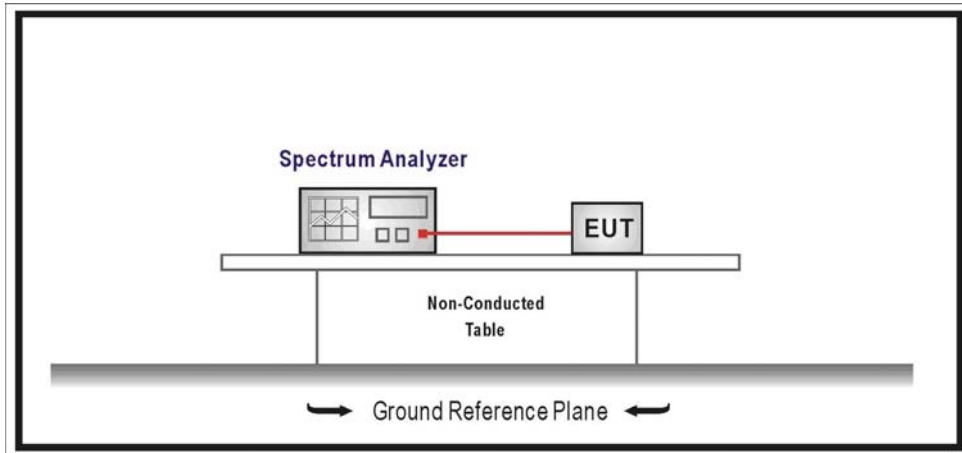

8.2. Limits

The peak power spectral density conducted from the intentional radiated to the antenna shall not be greater than +8dBm in any 3kHz band during any time interval of continuous transmission.

8.3. Test Procedures

The EUT was setup according to ANSI C63.10: 2013; tested according to DTS test procedure of KDB558074 V05 r02 for compliance to FCC 47CFR 15.247 requirements.

8.4. Test Specification

According to FCC Part 15 Subpart C Paragraph 15.247 and ISED RSS-247.

8.5. Test Result

Product	Bicycle Light		
Test Item	Power Density		
Test Mode	Mode 1 : Transmit Mode_Power by Adapter		
Date of Test	2019/12/25	Test Site	SR12-H
Temperature (°C)	21.5	Humidity (%RH)	55.0

Channel No.	Frequency (MHz)	Measure Vaule (dBm/RBW)	Limit (dBm/3kHz)
00	2402	-9.323	≤8
19	2440	-9.624	≤8
39	2480	-10.114	≤8

Channel 00

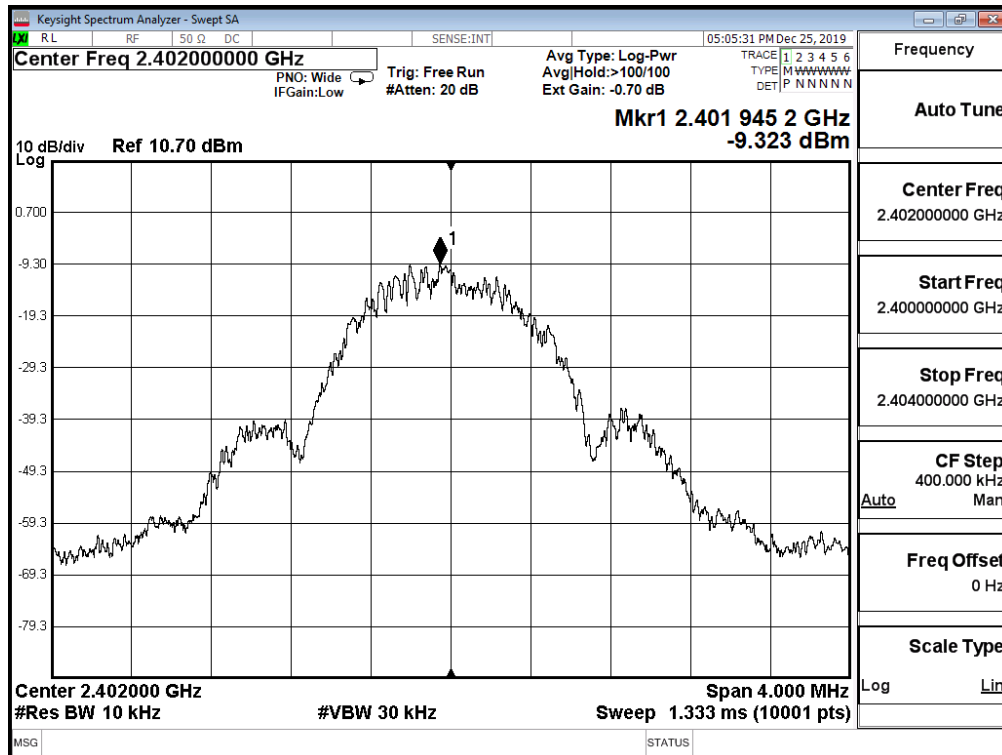

Channel 19

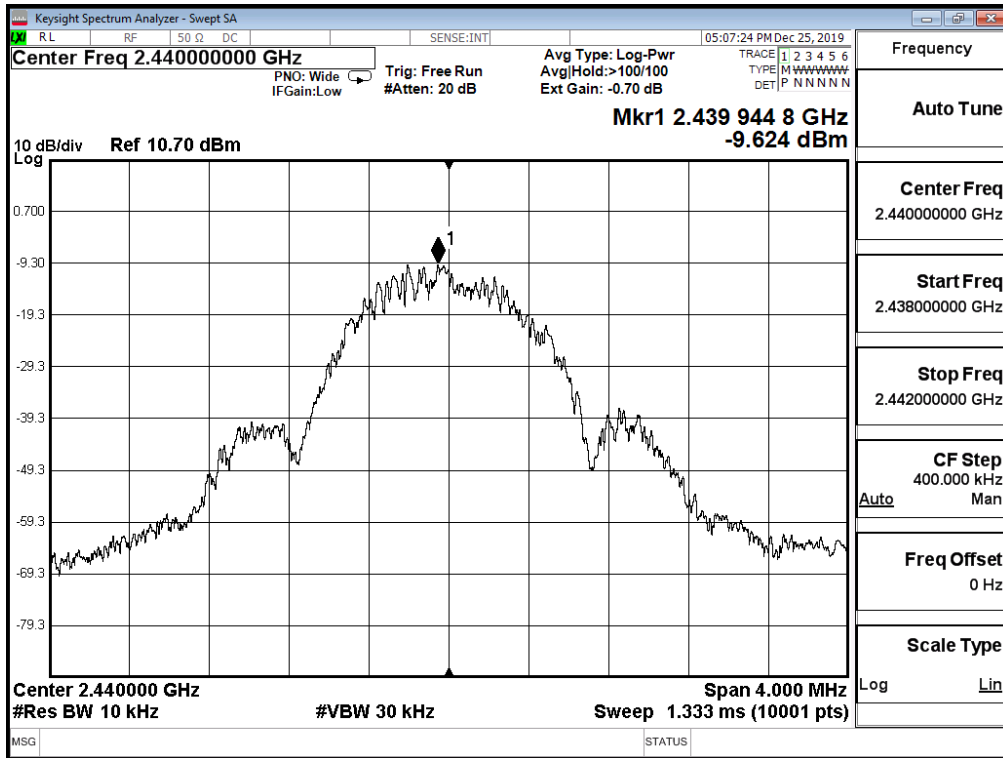

Channel 39

