



FCC Report

Application Purpose : Original grant
Applicant Name: : METEC ELECTRONICS CO., LTD.
FCC ID : 2AD38SPME51
Equipment Type : MULTIMEDIA SPEAKER
Model Name : SPME51, EM-3628FT, EM-36XXFT (XX instead of 01-99)
Report Number : FCC15080101
Standard(S) : FCC Part 15 Subpart C
Date Of Receipt : August 11, 2015
Date Of Issue : August 18, 2015

Test By :

(Fall Ma)

Reviewed By :

(Robie Chen)

Authorized by :

(Michal Ling)

Prepared by :
Shenzhen WST Testing Technology Co., Ltd.
1F, No.9 Building, TGK Science & Technology Park Yangtian Rd., NO.72 Bao'an Dist., GuangDong, China

REPORT REVISE RECORD

Report Version	Revise Time	Issued Date	Valid Version	Notes
V1.0	/	August 18, 2015	Valid	Original Report

Table of Contents	Page
1. GENERAL INFORMATION	5
2. TEST DESCRIPTION	7
2.1 MEASUREMENT UNCERTAINTY	7
2.2 DESCRIPTION OF TEST MODES	8
2.3 TABLE OF PARAMETERS OF TEXT SOFTWARE SETTING	9
2.4 CONFIGURATION OF SYSTEM UNDER TEST	9
2.5 PERIPHERALS EQUIPMENT LIST	9
2.6 DESCRIPTION OF SUPPORT UNITS (CONDUCTED MODE)	10
3. SUMMARY OF TEST RESULTS	11
4. MEASUREMENT INSTRUMENTS	12
5. EMC EMISSION TEST	13
5.1 CONDUCTED EMISSION MEASUREMENT	13
5.1.1 POWER LINE CONDUCTED EMISSION LIMITS	13
5.1.2 TEST PROCEDURE	14
5.1.3 DEVIATION FROM TEST STANDARD	14
5.1.4 TEST SETUP	14
5.1.5 EUT OPERATING CONDITIONS	14
5.1.6 TEST RESULTS	15
5.2 RADIATED EMISSION MEASUREMENT	17
5.2.1 RADIATED EMISSION LIMITS	17
5.2.2 TEST PROCEDURE	17
5.2.3 DEVIATION FROM TEST STANDARD	18
5.2.4 TEST SETUP	19
5.2.5 EUT OPERATING CONDITIONS	20
5.2.5.1 RESULTS (BELOW 30 MHZ)	21
5.2.5.2 TEST RESULTS (BETWEEN 30M – 1000 MHZ)	22
5.2.5.3 TEST RESULTS(1GHZ TO 25GHZ)	24
5.3 CONDUCTED SPURIOUS EMISSION MEASUREMENT	32
5.3.1 CONDUCTED SPURIOUS EMISSION LIMITS	32
5.3.2 TEST PROCEDURE	32
5.3.3 DEVIATION FROM STANDARD	32
5.3.4 TEST SETUP	32
5.3.5 EUT OPERATION CONDITIONS	32
5.3.6 TEST RESULTS	33
6. NUMBER OF HOPPING CHANNEL	
6.1 APPLIED PROCEDURES / LIMIT	41

Table of Contents	Page
6.2 TEST PROCEDURE	41
6.3 DEVIATION FROM STANDARD	41
6.4 TEST SETUP	41
6.5 EUT OPERATION CONDITIONS	41
6.6 TEST RESULTS	42
7. AVERAGE TIME OF OCCUPANCY	
7.1 APPLIED PROCEDURES / LIMIT	43
7.2 TEST PROCEDURE	43
7.3 DEVIATION FROM STANDARD	43
7.4 TEST SETUP	44
7.5 EUT OPERATION CONDITIONS	44
7.6 TEST RESULTS	45
8. HOPPING CHANNEL SEPARATION MEASUREMENT	
8.1 APPLIED PROCEDURES / LIMIT	47
8.2 TEST PROCEDURE	47
8.3 DEVIATION FROM STANDARD	47
8.4 TEST SETUP	47
8.5 EUT OPERATION CONDITIONS	47
8.6 TEST RESULTS	48
9. BANDWIDTH TEST	
9.1 APPLIED PROCEDURES / LIMIT	54
9.2 TEST PROCEDURE	54
9.3 DEVIATION FROM STANDARD	54
9.4 TEST SETUP	54
9.5 EUT OPERATION CONDITIONS	54
9.6 TEST RESULTS	55
10. PEAK OUTPUT POWER TEST	
10.1 APPLIED PROCEDURES / LIMIT	61
10.2 TEST PROCEDURE	61
10.3 DEVIATION FROM STANDARD	61
10.4 TEST SETUP	61
10.5 EUT OPERATION CONDITIONS	61
10.6 TEST RESULTS	62
11. ANTENNA APPLICATION	63
12. EUT TEST PHOTO	64
13. PHOTOGRAPHS OF EUT	66

1. GENERAL INFORMATION

GENERAL DESCRIPTION OF EUT

Test Model	SPME51
Derivative Model Name	EM-3628FT, EM-36XXFT(XX instead of 01-99)
Model difference	All models are identical in circuitry and electrical, mechanical and physical construction, only different on model name, color and size. All tests are carried out on SPME51.
Applicant	METEC ELECTRONICS CO., LTD.
Address	Building D, No. 4 Industrial Zone of Shasan Village, Shajing Town, Bao'an District, Shenzhen, China
Manufacturer	SHENZHEN BEYEAR APPLIANCE CO., LTD.
Address	Building D, No. 4 Industrial Zone of Shasan Village, Shajing Town, Bao'an District, Shenzhen, China
Equipment Type	MULTIMEDIA SPEAKER
Brand Name	
Hardware version:	EM-5028-CON-DATE120728 VER1.0
Software version:	VER1.0.0
Extreme Temp. Tolerance	-10°C to +50°C
Operating Voltage	Input: AC 120V 60Hz
Operating Frequency	2402-2480MHz
Channels	79
Channel Spacing	1MHz
Modulation Type	GFSK, $\pi/4$ -DQPSK, 8-DPSK
Version	2.1+EDR
Antenna Type:	PCB Antenna
Antenna gain:	1.0dBi
Data of receipt	August 11, 2015
Date of test	August 11, 2015 to August 18, 2015
Deviation	None
Condition of Test Sample	Normal

We hereby certify that:

The above equipment was tested by Shenzhen WST Testing Technology Co., Ltd.

Registration Number: 939433

The data evaluation, test procedures, and equipment configurations shown in this report were made in accordance with the procedures given in ANSI C 63.4:2009. The sample tested as described in this report is in compliance with the FCC Rules Part15 Subpart C.

The test results of this report relate only to the tested sample identified in this report.

2. TEST DESCRIPTION

2.1 MEASUREMENT UNCERTAINTY

The reported uncertainty of measurement $y \pm U$, where expanded uncertainty U is based on a standard uncertainty multiplied by a coverage factor of $k=2$, providing a level of confidence of approximately **95 %**.

No.	Item	Uncertainty
1	Conducted Emission Test	± 3.2 dB
2	RF power, conducted	± 0.16 dB
3	Spurious emissions, conducted	± 0.21 dB
4	All emissions, radiated(<1G)	± 4.7 dB
5	All emissions, radiated(>1G)	± 4.7 dB
6	Temperature	± 0.5 °C
7	Humidity	± 2 %

2.2 DESCRIPTION OF TEST MODES

To investigate the maximum EMI emission characteristics generates from EUT, the test system was pre-scanning tested base on the consideration of following EUT operation mode or test configuration mode which possible have effect on EMI emission level. Each of these EUT operation mode(s) or test configuration mode(s) mentioned above was evaluated respectively.

Pretest Mode	Description
Mode 1	CH00
Mode 2	CH39
Mode 3	CH78
Mode 4	Normal Hopping

For Conducted Emission	
Final Test Mode	Description
Mode 4	Normal Hopping

For Radiated Emission	
Final Test Mode	Description
Mode 1	CH00
Mode 2	CH39
Mode 3	CH78

Note:

- (1) The measurements are performed at the highest, middle, lowest available channels.**
- (2)The data rate was set in 1Mbps, 2 Mbps, 3 Mbps for radiated emission due to the highest RF output power.**
- (3) Record the worst case of each test item in this report.**

2.3 TABLE OF PARAMETERS OF TEXT SOFTWARE SETTING

During testing channel & power controlling software provided by the customer was used to control the operating channel as well as the output power level. The RF output power selection is for the setting of RF output power expected by the customer and is going to be fixed on the firmware of the final end product power parameters of FHSS

Test software Version	N/A		
Frequency	2402 MHz	2441 MHz	2480 MHz
Parameters(1Mbps)	DEF	DEF	DEF
Parameters(2Mbps)	DEF	DEF	DEF
Parameters(3Mbps)	DEF	DEF	DEF

2.4 CONFIGURATION OF SYSTEM UNDER TEST

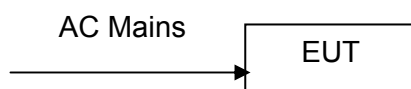

(EUT: MULTIMEDIA SPEAKER)

2.5 PERIPHERALS EQUIPMENT LIST

Item	Equipment	Model No.	ID or Specification	Remark
1	N/A	N/A	N/A	N/A

2.6 DESCRIPTION OF SUPPORT UNITS (CONDUCTED MODE)

The EUT has been tested as an independent unit together with other necessary accessories or support units. The following support units or accessories were used to form a representative test configuration during the tests.

Item	Equipment	Mfr/Brand	Model/Type No.	Series No.	Note
1	/	/	/	/	/

Note:

- (1) The support equipment was authorized by Declaration of Confirmation.
- (2) For detachable type I/O cable should be specified the length in cm in 『Length』 column.
- (3) “YES” is means “shielded” “with core”; “NO” is means “unshielded” “without core”.
- (4) The adapter supply by the applicant.

3. SUMMARY OF TEST RESULTS

Test procedures according to the technical standards:

FCC Part15 (15.247) , Subpart C			
Standard Section	Test Item	Judgment	Remark
15.207	Conducted Emission	PASS	
15.247(a)(1)	Hopping Channel Separation	PASS	
15.247(b)(1)	Peak Output Power	PASS	
15.247(c)	Radiated Spurious Emission	PASS	
15.247(d)	Conducted Spurious Emission	PASS	
15.247(a)(iii)	Number of Hopping Frequency	PASS	
15.247(a)(iii)	Dwell Time	PASS	
15.247(a)(1)	Bandwidth	PASS	
15.205	Band Edge Emission	PASS	
15.203	Antenna Requirement	PASS	

NOTE:

(1) "N/A" denotes test is not applicable in this test report.

4. MEASUREMENT INSTRUMENTS

Kind of Equipment	Manufacturer	Type No.	Serial No.	Last Calibrated	Calibrated until
ESPI Test Receiver	R&S	ESPI	100379	2014-08-19	2015-08-18
EMI Test Receiver	R&S	ESCI	100005	2014-08-19	2015-08-18
LISN	Mestec	AN3016	04/10040	2014-08-19	2015-08-18
Coaxial cable	Megalon	LMR400	C001	2014-08-19	2015-08-18
System Controller	CT	SC100	011208	2014-08-19	2015-08-18
Bi-log Antenna	Chase	CBL6111C	2576	2014-08-19	2015-08-18
Spectrum analyzer	R&S	FSU26	200409	2014-08-19	2015-08-18
Horn Antenna	SCHWARZBECK	9120D	1141	2014-08-19	2015-08-18
Bi-log Antenna	Schwarebeck	VULB9163	9163/340	2014-08-19	2015-08-18
Loop Antenna	EMCO	6502	00042960	2014-08-22	2015-08-21
Pre Amplifier	H.P.	HP8447E	2945A02715	2014-10-13	2015-10-12
Pre-Amplifier	CDSI	PAP-1G18-38	7621	2014-10-13	2015-10-12
8*4*3 Anechoic	SAEMC	L×W×H 8×4×3	A001	2014-08-21	2015-08-20
9*6*6 Anechoic	SAEMC	L×W×H 9×6×6	A002	2014-08-21	2015-08-20
Power meter	Anritsu	ML2487A	6K00003613	2014-08-23	2015-08-22
H & T Chamber	Guangzhou gongwen	GDJS-500-40	0329	2014-08-19	2015-08-18
MXA Signal Analyzer	Aglient	N9020A	54123254	2014-08-19	2015-08-18
Power sensor	Anritsu	MX248XD	95327410	2014-08-19	2015-08-18
RF cable	H+S	SUCOFLEX 102	R002	2014-08-19	2015-08-18
Horn Antenna	SCHWARZBECK	BBHA 9170	1123	2014-08-19	2015-08-18

5. EMC EMISSION TEST

5.1 CONDUCTED EMISSION MEASUREMENT

5.1.1 POWER LINE CONDUCTED EMISSION Limits (Frequency Range 150KHz-30MHz)

FREQUENCY (MHz)	Class A (dBuV)		Class B (dBuV)		Standard
	Quasi-peak	Average	Quasi-peak	Average	
0.15 -0.5	79.00	66.00	66 - 56 *	56 - 46 *	FCC
0.50 -5.0	73.00	60.00	56.00	46.00	FCC
5.0 -30.0	73.00	60.00	60.00	50.00	FCC

Note:

- (1) The tighter limit applies at the band edges.
- (2) The limit of " * " marked band means the limitation decreases linearly with the logarithm of the frequency in the range.

The following table is the setting of the receiver

Receiver Parameters	Setting
Attenuation	10 dB
Start Frequency	0.15 MHz
Stop Frequency	30 MHz
IF Bandwidth	9 kHz

5.1.2 TEST PROCEDURE

- The EUT was placed 0.4 meters from the horizontal ground plane with EUT being connected to the power mains through a line impedance stabilization network (LISN). All other support equipments powered from additional LISN(s). The LISN provide 50 Ohm/ 50uH of coupling impedance for the measuring instrument.
- Interconnecting cables that hang closer than 40 cm to the ground plane shall be folded back and forth in the center forming a bundle 30 to 40 cm long.
- I/O cables that are not connected to a peripheral shall be bundled in the center. The end of the cable may be terminated, if required, using the correct terminating impedance. The overall length shall not exceed 1 m.
- LISN at least 80 cm from nearest part of EUT chassis.
- For the actual test configuration, please refer to the related Item –EUT Test Photos.

5.1.3 DEVIATION FROM TEST STANDARD

No deviation

5.1.4 TEST SETUP

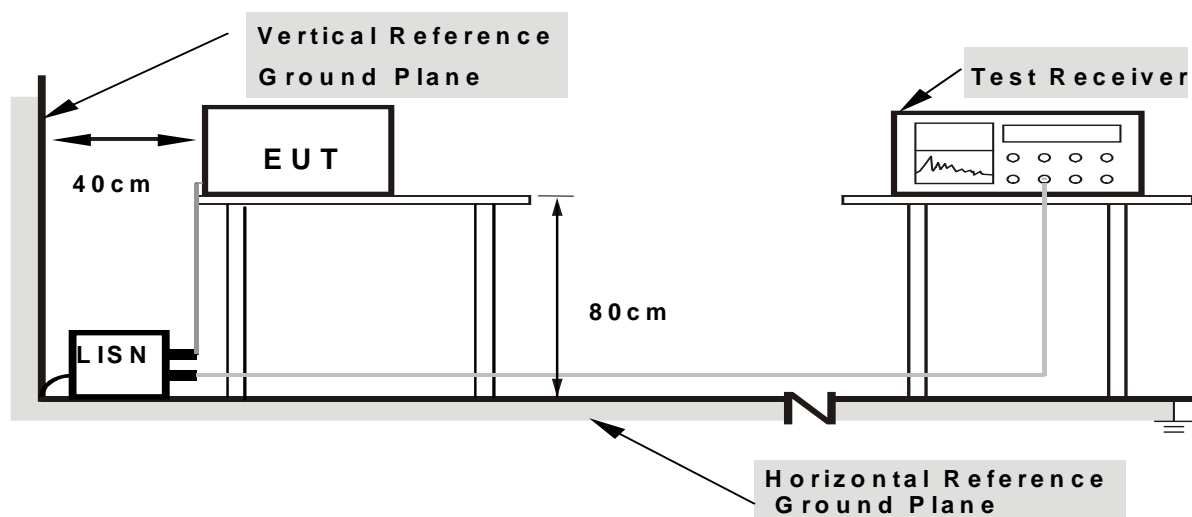

- Note:** 1. Support units were connected to second LISN.
 2. Both of LISNs (AMN) are 80 cm from EUT and at least 80 cm from other units and other metal planes

5.1.5 EUT OPERATING CONDITIONS

The EUT was configured for testing in a typical fashion (as a customer would normally use it). The EUT has been programmed to continuously transmit during test. This operating condition was tested and used to collect the included data.

5.1.6 TEST RESULTS

EUT	MULTIMEDIA SPEAKER	Model Name	SPME51
Temperature	24 °C	Relative Humidity	54%
Pressure	1010hPa	Phase	L
Test Date	August 15, 2015	Test Mode	Mode 4
Test Voltage	AC120V/60Hz:		

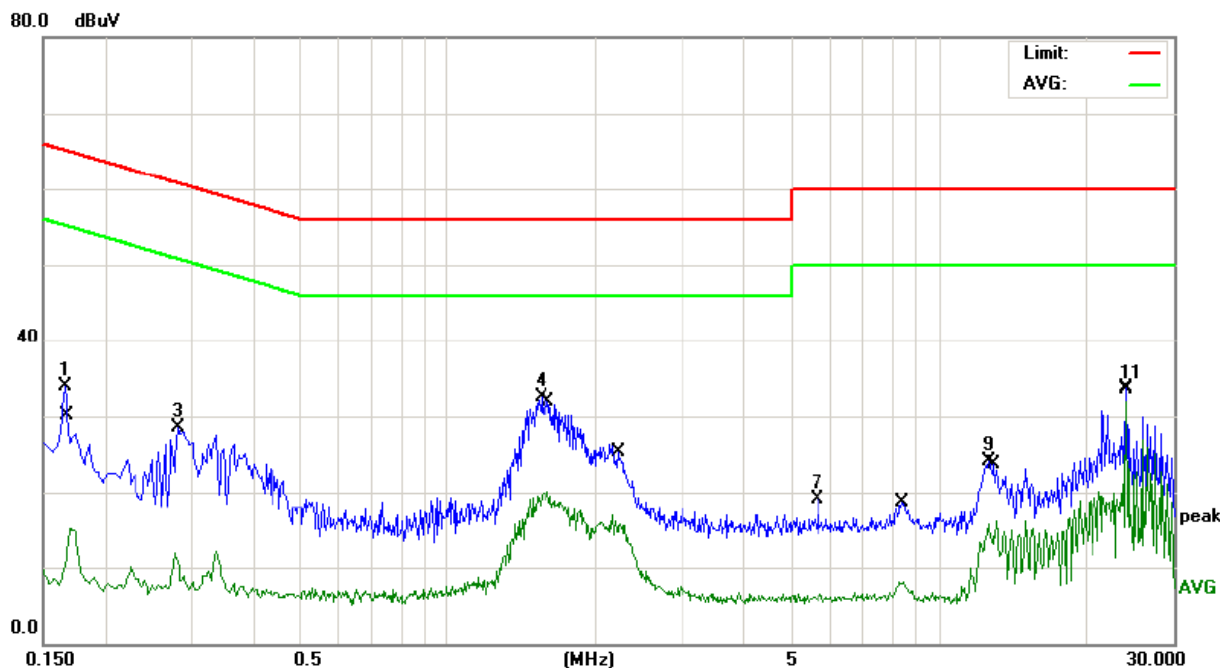

No.	Mk.	Freq. MHz	Reading Level dBuV	Correct Factor dB	Measure- ment dBuV	Limit dBuV	Over dB	Detector
1		0.1660	23.53	10.40	33.93	65.15	-31.22	peak
2		0.1700	4.64	10.39	15.03	54.96	-39.93	AVG
3		0.2819	17.93	10.59	28.52	60.76	-32.24	peak
4		1.5460	21.81	10.73	32.54	56.00	-23.46	peak
5		1.5940	9.33	10.73	20.06	46.00	-25.94	AVG
6		2.1900	5.40	10.71	16.11	46.00	-29.89	AVG
7		5.6740	8.47	10.57	19.04	60.00	-40.96	peak
8		8.4340	-2.37	10.46	8.09	50.00	-41.91	AVG
9		12.6300	13.75	10.43	24.18	60.00	-35.82	peak
10		13.1140	5.65	10.43	16.08	50.00	-33.92	AVG
11		24.0340	23.06	10.54	33.60	60.00	-26.40	peak
12	*	24.0340	21.30	10.54	31.84	50.00	-18.16	AVG

Remark: All the modes have been investigated, and only worst mode is presented in this report.

EUT	MULTIMEDIA SPEAKER	Model Name	SPME51
Temperature	24 °C	Relative Humidity	54%
Pressure	1010hPa	Phase	N
Test Date	August 15, 2015	Test Mode	Mode 4
Test Voltage	AC120V/60Hz		

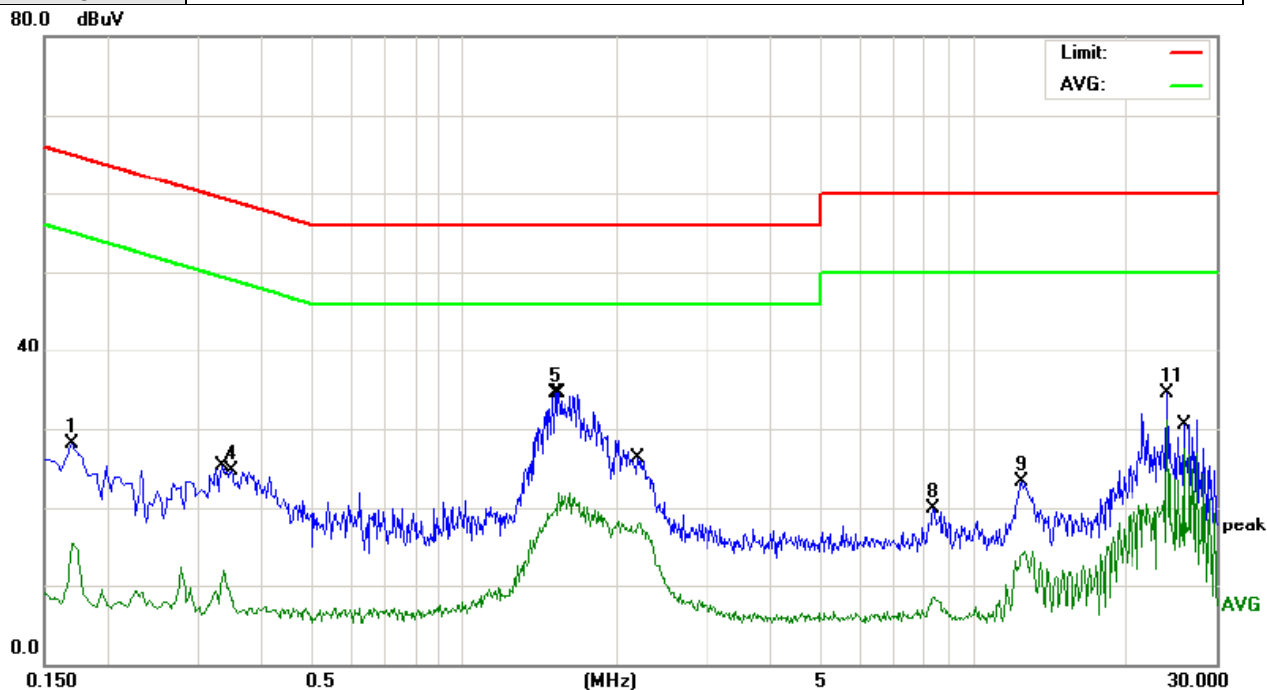

No.	Mk.	Freq. MHz	Reading Level dBuV	Correct Factor dB	Measure- ment dBuV	Limit dBuV	Over dB	Detector
1		0.1700	17.64	10.39	28.03	64.96	-36.93	peak
2		0.1700	4.86	10.39	15.25	54.96	-39.71	AVG
3		0.3379	1.24	10.59	11.83	49.25	-37.42	AVG
4		0.3500	14.13	10.57	24.70	58.96	-34.26	peak
5	*	1.5060	23.86	10.73	34.59	56.00	-21.41	peak
6		1.5300	11.11	10.73	21.84	46.00	-24.16	AVG
7		2.2020	7.49	10.70	18.19	46.00	-27.81	AVG
8		8.3260	9.43	10.47	19.90	60.00	-40.10	peak
9		12.4940	12.86	10.42	23.28	60.00	-36.72	peak
10		12.5860	3.87	10.43	14.30	50.00	-35.70	AVG
11		24.0340	23.95	10.54	34.49	60.00	-25.51	peak
12		25.9140	16.92	10.56	27.48	50.00	-22.52	AVG

Remark: All the modes have been investigated, and only worst mode is presented in this report.

Report No.: FCC15080101

5.2 RADIATED EMISSION MEASUREMENT

5.2.1 RADIATED EMISSION LIMITS (Frequency Range 9kHz-1000MHz)

20dBc in any 100 kHz bandwidth outside the operating frequency band. In case the emission fall within the restricted band specified on 15.205(a), then the 15.209(a) limit in the table below has to be followed.

Frequencies (MHz)	Field Strength (micorvolts/meter)	Measurement Distance (meters)
0.009~0.490	2400/F(KHz)	300
0.490~1.705	24000/F(KHz)	30
1.705~30.0	30	30
30~88	100	3
88~216	150	3
216~960	200	3
Above 960	500	3

LIMITS OF RADIATED EMISSION MEASUREMENT (Above 1000MHz)

FREQUENCY (MHz)	Limit (dBuV/m) (at 3M)	
	PEAK	AVERAGE
Above 1000	74	54

Notes:

- (1) The limit for radiated test was performed according to FCC PART 15C.
- (2) The tighter limit applies at the band edges.
- (3) Emission level (dBuV/m)=20log Emission level (uV/m).

Spectrum Parameter	Setting
Attenuation	Auto
Start Frequency	1000 MHz
Stop Frequency	10th carrier harmonic
RB / VB (emission in restricted band)	1 MHz / 1 MHz for Peak, 1 MHz / 10Hz for Average

Receiver Parameter	Setting
Attenuation	Auto
Start ~ Stop Frequency	9kHz~150kHz / RB 200Hz for QP
Start ~ Stop Frequency	150kHz~30MHz / RB 9kHz for QP
Start ~ Stop Frequency	30MHz~1000MHz / RB 120kHz for QP

5.2.2 TEST PROCEDURE

- a. The measuring distance of at 3 m shall be used for measurements at frequency up to 1GHz. For frequencies above 1GHz, any suitable measuring distance may be used.

- b. The EUT was placed on the top of a rotating table 0.8 meters above the ground at a 3 meter open area test site. The table was rotated 360 degrees to determine the position of the highest radiation.
- c. The height of the equipment or of the substitution antenna shall be 0.8 m; the height of the test antenna shall vary between 1 m to 4 m. Both horizontal and vertical polarizations of the antenna are set to make the measurement.
- d. The initial step in collecting conducted emission data is a spectrum analyzer peak detector mode pre-scanning the measurement frequency range. Significant peaks are then marked and then Quasi Peak detector mode re-measured.
- e. If the Peak Mode measured value compliance with and lower than Quasi Peak Mode Limit, the EUT shall be deemed to meet QP Limits and then no additional QP Mode measurement performed.
- f. For the actual test configuration, please refer to the related Item –EUT Test Photos.

Note:

***Both horizontal and vertical antenna polarities were tested.
The worst case emissions were reported***

5.2.3 DEVIATION FROM TEST STANDARD

No deviation

5.2.4 TEST SETUP

(A) Radiated Emission Test-Up Frequency Below 30MHz

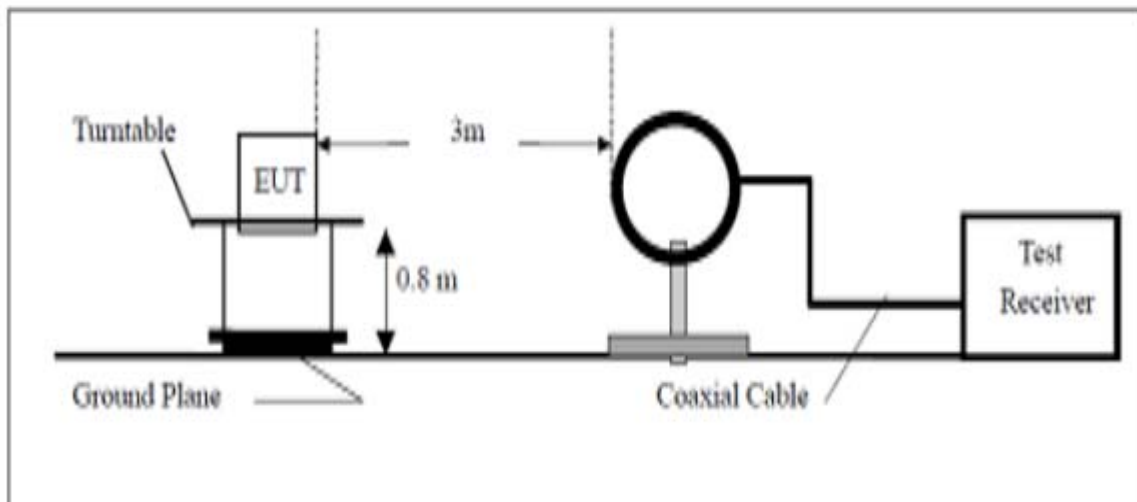

(B) Radiated Emission Test-Up Frequency 30MHz~1GHz

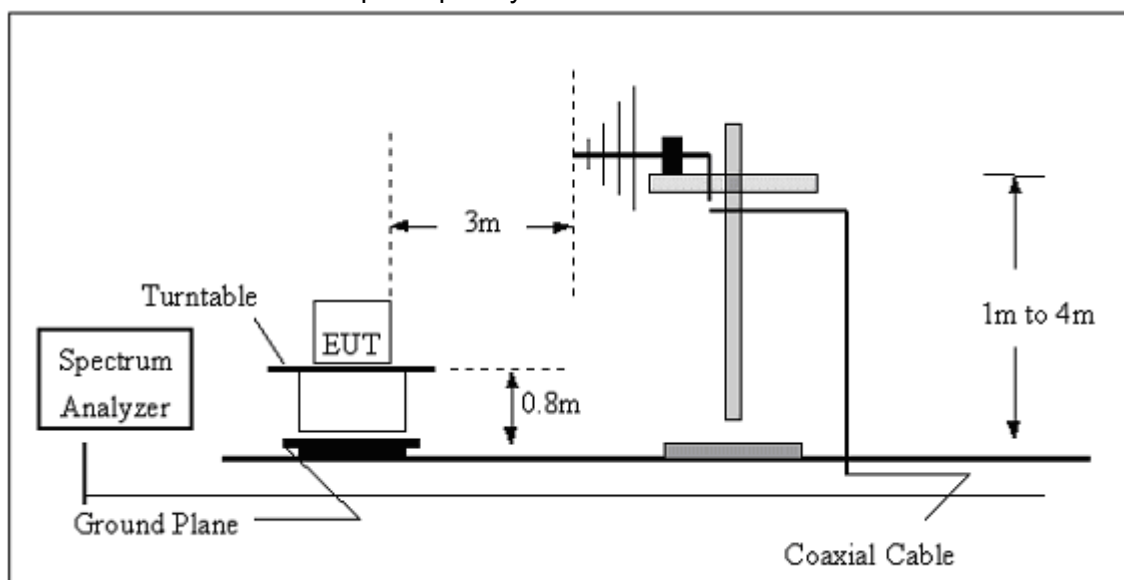

(C) Radiated Emission Test-Up Frequency Above 1GHz

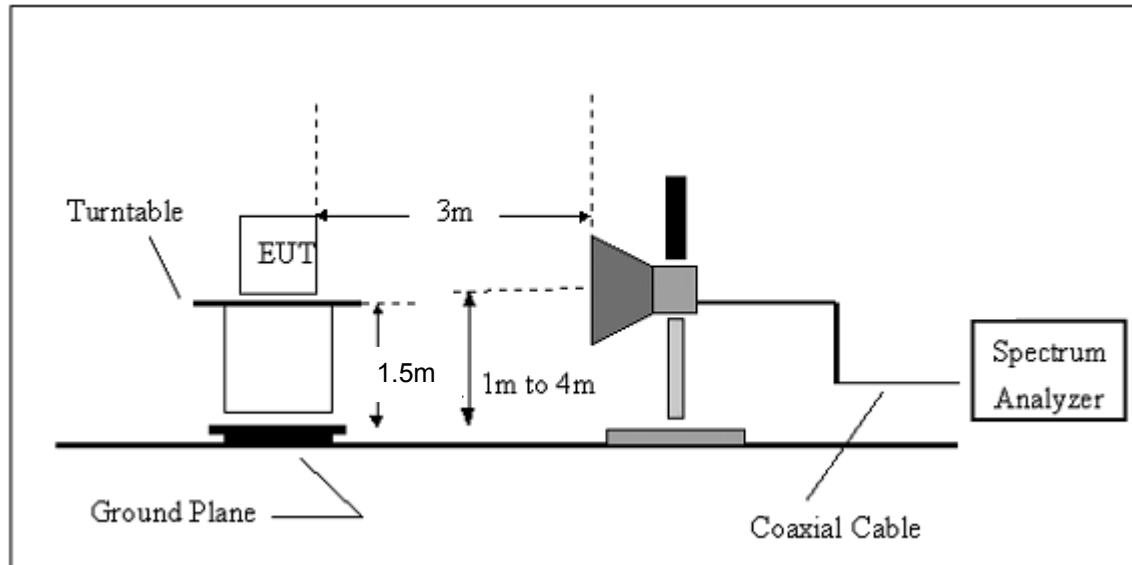
**5.2.5 EUT OPERATING CONDITIONS**

The EUT tested system was configured as the statements of 2.4 Unless otherwise a special operating condition is specified in the follows during the testing.

5.2.5.1 RESULTS (BELOW 30 MHZ)

EUT	MULTIMEDIA SPEAKER	Model Name	SPME51
Temperature	20 °C	Relative Humidity	48%
Pressure	1010 hPa	Polarization	---
Test Mode	Mode 1/ Mode 2/ Mode 3/ Mode 4	Test Date	August 15, 2015

Freq.	Reading	Limit	Margin	State
(MHz)	(dBuV/m)	(dBuV/m)	(dB)	P/F
--	--	--	--	P
--	--	--	--	P

NOTE:

No result in this part for margin above 20dB.

Distance extrapolation factor =20 log (specific distance/test distance)(dB);

Limit line = specific limits (dBuV) + distance extrapolation factor.

5.2.5.2 TEST RESULTS (BETWEEN 30M – 1000 MHZ)

EUT	MULTIMEDIA SPEAKER	Model Name	SPME51
Temperature	20 °C	Relative Humidity	48%
Pressure	1010 hPa	Polarization :	Horizontal
Test Mode	Mode 1 with 1Mbps(GFSK)	Test Date	August 15, 2015

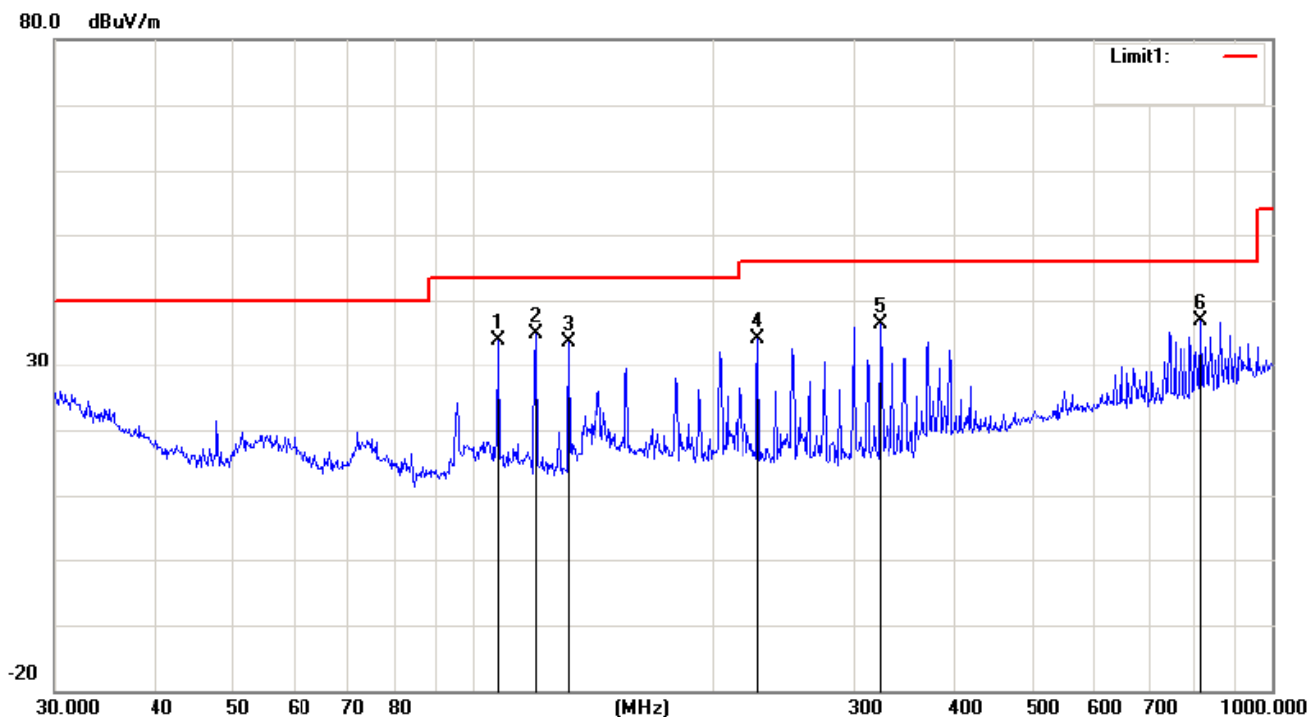

No.	Mk.	Freq. MHz	Reading Level dBuV	Correct Factor dB	Measure- ment dBuV/m	Limit dBuV/m	Over dB	Detector
1		107.8876	38.00	-4.16	33.84	43.50	-9.66	peak
2	*	119.8555	37.24	-2.33	34.91	43.50	-8.59	peak
3		131.7576	36.15	-2.49	33.66	43.50	-9.84	peak
4		227.6905	39.84	-5.80	34.04	46.00	-11.96	peak
5		323.3204	40.87	-4.59	36.28	46.00	-9.72	peak
6		815.9678	32.03	4.94	36.97	46.00	-9.03	peak

Remark: All the modes have been investigated, and only worst mode is presented in this report.

EUT	MULTIMEDIA SPEAKER	Model Name	SPME51
Temperature	20 °C	Relative Humidity	48%
Pressure	1010 hPa	Polarization :	Vertical
Test Mode	Mode 1 with 1Mbps(GFSK)	Test Date	August 15, 2015

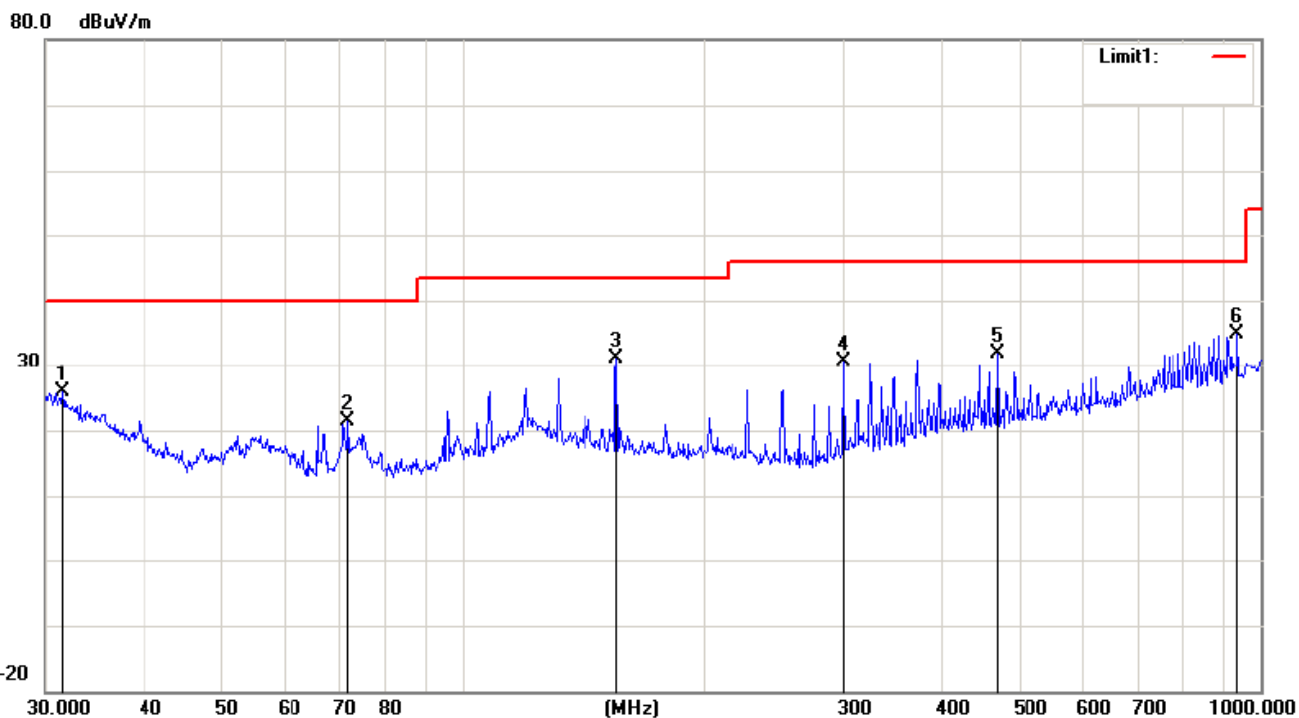

No.	Mk.	Freq. MHz	Reading Level dBuV	Correct Factor dB	Measure- ment dBuV/m	Limit dBuV/m	Over dB	Detector
1		31.5095	23.44	2.47	25.91	40.00	-14.09	peak
2		71.8320	29.13	-7.71	21.42	40.00	-18.58	peak
3		155.9101	35.40	-4.24	31.16	43.50	-12.34	peak
4		299.3158	36.33	-5.75	30.58	46.00	-15.42	peak
5		467.2349	33.34	-1.47	31.87	46.00	-14.13	peak
6	*	935.5463	28.42	6.53	34.95	46.00	-11.05	peak

Remark: All the modes have been investigated, and only worst mode is presented in this report.

5.2.5.3 TEST RESULTS(1GHZ TO 25GHZ)

Note: *the worst case is 1Mbps(GFSK)mode as result in this part.*

EUT	MULTIMEDIA SPEAKER	Model Name	SPME51
Temperature	20 °C	Relative Humidity	48%
Pressure	1010 hPa	Test Mode	Mode 1 TX(1Mbps)
Test Date	August 15, 2015		

Freq. (MHz)	Ant. Pol.	Emission Level(dBuV)		Limit 3m(dBuV/m)		Over(dB)	
		PK	AV	PK	AV	PK	AV
4804	V	60.48	40.03	74	54	-13.52	-13.97
7206	V	59.53	40.59	74	54	-14.47	-13.41
4804	H	59.38	39.06	74	54	-14.62	-14.94
7206	H	59.53	40.53	74	54	-14.47	-13.47

Remark:

All emissions not reported were more than 20dB below the specified limit or in the noise floor.
Only worst case is presented in this report.

EUT	MULTIMEDIA SPEAKER	Model Name	SPME51
Temperature	20 °C	Relative Humidity	48%
Pressure	1010 hPa	Test Mode	Mode 2 TX(1Mbps)
Test Date	August 15, 2015		

Freq. (MHz)	Ant.Pol.	Emission Level(dBuV)		Limit 3m(dBuV/m)		Over(dB)	
		PK	AV	PK	AV	PK	AV
4882	V	59.10	40.74	74	54	-14.90	-13.26
7323	V	58.44	40.60	74	54	-15.56	-13.40
4882	H	58.71	40.60	74	54	-15.29	-13.40
7323	H	58.50	39.50	74	54	-15.50	-14.50

Remark:

All emissions not reported were more than 20dB below the specified limit or in the noise floor.
Only worst case is presented in this report.

EUT	MULTIMEDIA SPEAKER	Model Name	SPME51
Temperature	20 °C	Relative Humidity	48%
Pressure	1010 hPa	Test Mode	Mode 3 TX(1Mbps)
Test Date	August 15, 2015		

Freq. (MHz)	Ant.Pol.	Emission Level(dBuV)		Limit 3m(dBuV/m)		Over(dB)	
		PK	AV	PK	AV	PK	AV
4960	V	60.09	40.43	74	54	-13.91	-13.57
7440	V	58.72	40.91	74	54	-15.28	-13.09
4960	H	59.91	39.86	74	54	-14.09	-14.14
7440	H	58.15	39.15	74	54	-15.85	-14.85

Remark:

All emissions not reported were more than 20dB below the specified limit or in the noise floor.
Only worst case is presented in this report.

5.2.5.4 TEST RESULTS (Restricted Bands Requirements)

Test result for 1Mbps Mode:

EUT	MULTIMEDIA SPEAKER	Model Name	SPME51
Temperature	20 °C	Relative Humidity	48%
Pressure	1010 hPa	Test Date	August 15, 2015
Test Mode	TX /2402MHz -1Mbps	Polarization	Vertical

Frequency	Meter Reading	Factor	Emission Level	Limits	Margin	Detector Type
(MHz)	(dB μ V)	(dB)	(dB μ V/m)	(dB μ V/m)	(dB)	
2382	61.28	-8.76	52.52	74	21.48	peak
2382	54.92	-8.76	46.16	54	7.84	AVG
2390	62.07	-8.73	53.34	74	20.66	peak
2390	57.60	-8.73	48.87	54	5.13	AVG

Remark:

Factor = Antenna Factor + Cable Loss – Pre-amplifier.
Only worst case is presented in this report.

EUT	MULTIMEDIA SPEAKER	Model Name	SPME51
Temperature	20 °C	Relative Humidity	48%
Pressure	1010 hPa	Test Date	August 15, 2015
Test Mode	TX /2402MHz-1Mbps	Polarization	Horizontal

Frequency	Meter Reading	Factor	Emission Level	Limits	Margin	Detector Type
(MHz)	(dB μ V)	(dB)	(dB μ V/m)	(dB μ V/m)	(dB)	
2376	63.16	-8.78	54.38	74	19.62	peak
2376	53.05	-8.78	44.27	54	9.73	AVG
2390	60.92	-8.73	52.19	74	21.81	peak
2390	54.56	-8.73	45.83	54	8.17	AVG

Remark:

Factor = Antenna Factor + Cable Loss – Pre-amplifier.
Only worst case is presented in this report.

EUT	MULTIMEDIA SPEAKER	Model Name	SPME51
Temperature	20 °C	Relative Humidity	48%
Pressure	1010 hPa	Test Date	August 15, 2015
Test Mode	TX /2480MHz-1Mbps	Polarization	Vertical

Frequency	Meter Reading	Factor	Emission Level	Limits	Margin	Detector Type
(MHz)	(dBμV)	(dB)	(dBμV/m)	(dBμV/m)	(dB)	
2483.5	62.81	-8.17	54.64	74	19.36	peak
2483.5	53.99	-8.17	45.82	54	8.18	AVG

Remark:
Factor = Antenna Factor + Cable Loss – Pre-amplifier.
Only worst case is presented in this report.

EUT	MULTIMEDIA SPEAKER	Model Name	SPME51
Temperature	20 °C	Relative Humidity	48%
Pressure	1010 hPa	Test Date	August 15, 2015
Test Mode	TX /2480MHz-1Mbps	Polarization	Horizontal

Frequency	Meter Reading	Factor	Emission Level	Limits	Margin	Detector Type
(MHz)	(dBμV)	(dB)	(dBμV/m)	(dBμV/m)	(dB)	
2483.5	64.99	-8.17	56.82	74	17.18	peak
2483.5	53.39	-8.17	45.22	54	8.78	AVG

Remark:
Factor = Antenna Factor + Cable Loss – Pre-amplifier.
Only worst case is presented in this report.

Test result for 3Mbps Mode:

EUT	MULTIMEDIA SPEAKER	Model Name	SPME51
Temperature	20 °C	Relative Humidity	48%
Pressure	1010 hPa	Test Date	August 15, 2015
Test Mode	TX /2402MHz-3Mbps	Polarization	Vertical

Frequency	Meter Reading	Factor	Emission Level	Limits	Margin	Detector Type
(MHz)	(dB μ V)	(dB)	(dB μ V/m)	(dB μ V/m)	(dB)	
2387	64.92	-8.74	56.18	74	17.82	peak
2387	53.71	-8.74	44.97	54	9.03	AVG
2390	61.98	-8.73	53.25	74	20.75	peak
2390	55.88	-8.73	47.15	54	6.85	AVG

Remark:

Factor = Antenna Factor + Cable Loss – Pre-amplifier.

Only worst case is presented in this report.

EUT	MULTIMEDIA SPEAKER	Model Name	SPME51
Temperature	20 °C	Relative Humidity	48%
Pressure	1010 hPa	Test Date	August 15, 2015
Test Mode	TX /2402MHz-3Mbps	Polarization	Horizontal

Frequency	Meter Reading	Factor	Emission Level	Limits	Margin	Detector Type
(MHz)	(dB μ V)	(dB)	(dB μ V/m)	(dB μ V/m)	(dB)	
2384	64.47	-8.75	55.72	74	18.28	peak
2384	56.18	-8.75	47.43	54	6.57	AVG
2390	59.30	-8.73	50.57	74	23.43	peak
2390	55.73	-8.73	47.00	54	7.00	AVG

Remark:

Factor = Antenna Factor + Cable Loss – Pre-amplifier.

Only worst case is presented in this report.

EUT	MULTIMEDIA SPEAKER	Model Name	SPME51
Temperature	20 °C	Relative Humidity	48%
Pressure	1010 hPa	Test Date	August 15, 2015
Test Mode	TX /2480MHz-3Mbps	Polarization	Vertical

Frequency	Meter Reading	Factor	Emission Level	Limits	Margin	Detector Type
(MHz)	(dBμV)	(dB)	(dBμV/m)	(dBμV/m)	(dB)	
2483.5	63.25	-8.17	55.08	74	18.92	peak
2483.5	53.27	-8.17	45.10	54	8.90	AVG

Remark:

Factor = Antenna Factor + Cable Loss – Pre-amplifier.

Only worst case is presented in this report.

EUT	MULTIMEDIA SPEAKER	Model Name	SPME51
Temperature	20 °C	Relative Humidity	48%
Pressure	1010 hPa	Test Date	August 15, 2015
Test Mode	TX /2480MHz-3Mbps	Polarization	Horizontal

Frequency	Meter Reading	Factor	Emission Level	Limits	Margin	Detector Type
(MHz)	(dBμV)	(dB)	(dBμV/m)	(dBμV/m)	(dB)	
2483.5	63.43	-8.17	55.26	74	18.74	peak
2483.5	54.42	-8.17	46.25	54	7.75	AVG

Remark:

Factor = Antenna Factor + Cable Loss – Pre-amplifier.

Only worst case is presented in this report.

Test result for hopping mode:

EUT	MULTIMEDIA SPEAKER	Model Name	SPME51
Temperature	20 °C	Relative Humidity	48%
Pressure	1010 hPa	Test Date	August 15, 2015
Test Mode	hopping mode	Polarization	Vertical

Frequency	Meter Reading	Factor	Emission Level	Limits	Margin	Detector Type
(MHz)	(dB μ V)	(dB)	(dB μ V/m)	(dB μ V/m)	(dB)	
2381	61.40	-8.76	52.64	74	21.36	peak
2381	53.61	-8.76	44.85	54	9.15	AVG
2390	59.54	-8.73	50.81	74	23.19	peak
2390	57.32	-8.73	48.59	54	5.41	AVG

Remark:

Factor = Antenna Factor + Cable Loss – Pre-amplifier.

Only worst case is presented in this report.

EUT	MULTIMEDIA SPEAKER	Model Name	SPME51
Temperature	20 °C	Relative Humidity	48%
Pressure	1010 hPa	Test Date	August 15, 2015
Test Mode	Hopping mode	Polarization :	Horizontal

Frequency	Meter Reading	Factor	Emission Level	Limits	Margin	Detector Type
(MHz)	(dB μ V)	(dB)	(dB μ V/m)	(dB μ V/m)	(dB)	
2378	61.71	-8.77	52.94	74	21.06	peak
2378	54.56	-8.77	45.79	54	8.21	AVG
2390	61.24	-8.73	52.51	74	21.49	peak
2390	54.65	-8.73	45.92	54	8.08	AVG

Remark:

Factor = Antenna Factor + Cable Loss – Pre-amplifier.

Only worst case is presented in this report.

EUT	MULTIMEDIA SPEAKER	Model Name	SPME51
Temperature	20 °C	Relative Humidity	48%
Pressure	1010 hPa	Test Date	August 15, 2015
Test Mode	Hopping mode	Polarization	Vertical

Frequency	Meter Reading	Factor	Emission Level	Limits	Margin	Detector Type
(MHz)	(dBμV)	(dB)	(dBμV/m)	(dBμV/m)	(dB)	
2483.5	64.63	-8.17	56.46	74	17.54	peak
2483.5	53.87	-8.17	45.70	54	8.30	AVG

Remark:
Factor = Antenna Factor + Cable Loss – Pre-amplifier.
Only worst case is presented in this report.

EUT	MULTIMEDIA SPEAKER	Model Name	SPME51
Temperature	20 °C	Relative Humidity	48%
Pressure	1010 hPa	Test Date	August 15, 2015
Test Mode	Hopping mode	Polarization	Horizontal

Frequency	Meter Reading	Factor	Emission Level	Limits	Margin	Detector Type
(MHz)	(dBμV)	(dB)	(dBμV/m)	(dBμV/m)	(dB)	
2483.5	64.39	-8.17	56.22	74	17.78	peak
2483.5	54.09	-8.17	45.92	54	8.08	AVG

Remark:
Factor = Antenna Factor + Cable Loss – Pre-amplifier.
Only worst case is presented in this report.

5.3 CONDUCTED SPURIOUS EMISSION MEASUREMENT

5.3.1 CONDUCTED SPURIOUS EMISSION LIMITS

FCC §15.247 (d)

Limit = -20 dBc

5.3.2 TEST PROCEDURE

According to the dictates of DA-000705

- a. The transmitter output is connected to a spectrum analyzer. The resolution bandwidth is set to 100 kHz. The video bandwidth is set to 300 kHz.
- b. The spectrum from 30 MHz to 25 GHz is investigated with the transmitter set to the lowest, middle, and highest channels.
- c. The band edges at 2.4 and 2.4835 GHz are investigated with the transmitter set to the normal hopping mode.

Note: The correction factor has been added to the spectrum analyzer.

5.3.3 DEVIATION FROM STANDARD

No deviation.

5.3.4 TEST SETUP

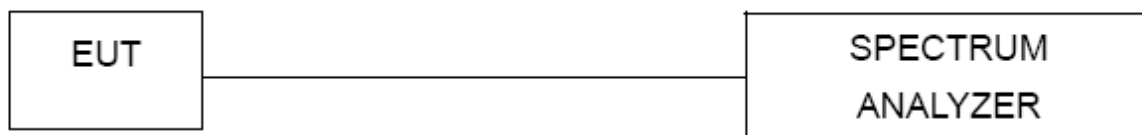

5.3.5 EUT OPERATION CONDITIONS

The EUT tested system was configured as the statements of 2.4 Unless otherwise a special operating condition is specified in the follows during the testing.

5.3.6 TEST RESULTS

Operating Mode: GFSK (1 Mbps)

Low Channel

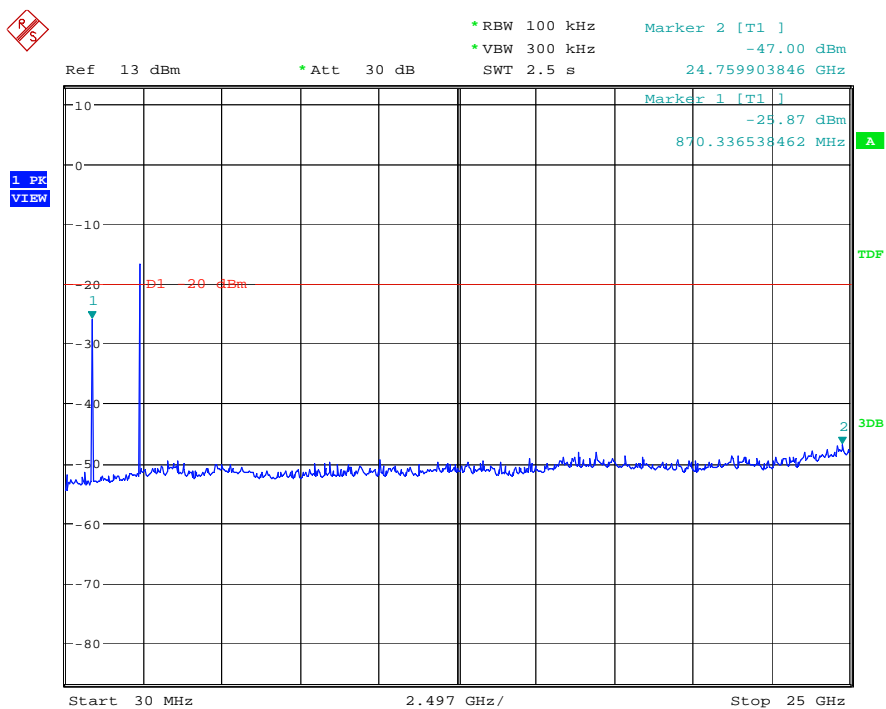
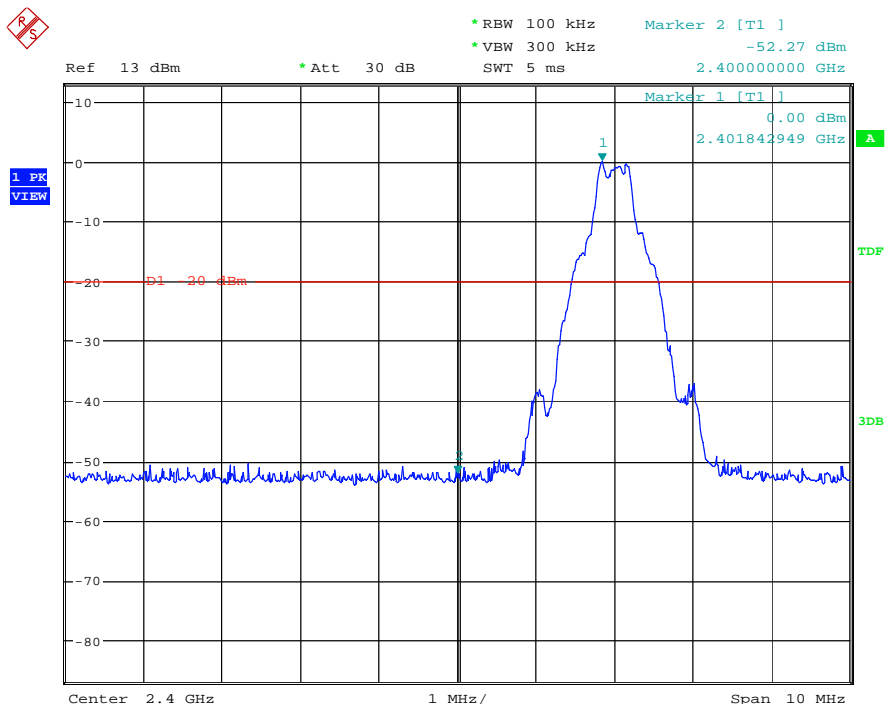

Middle Channel

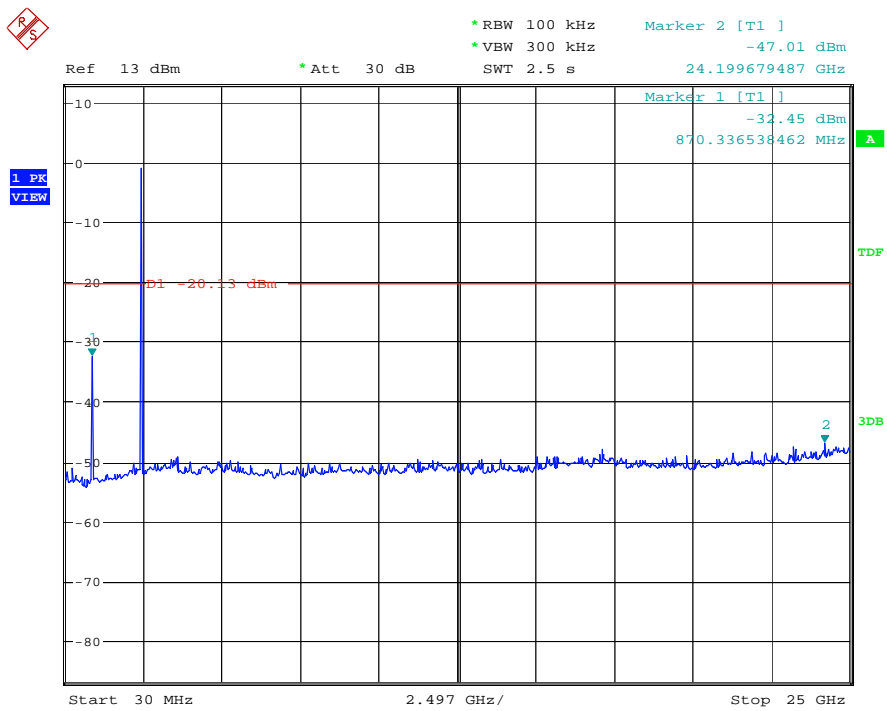
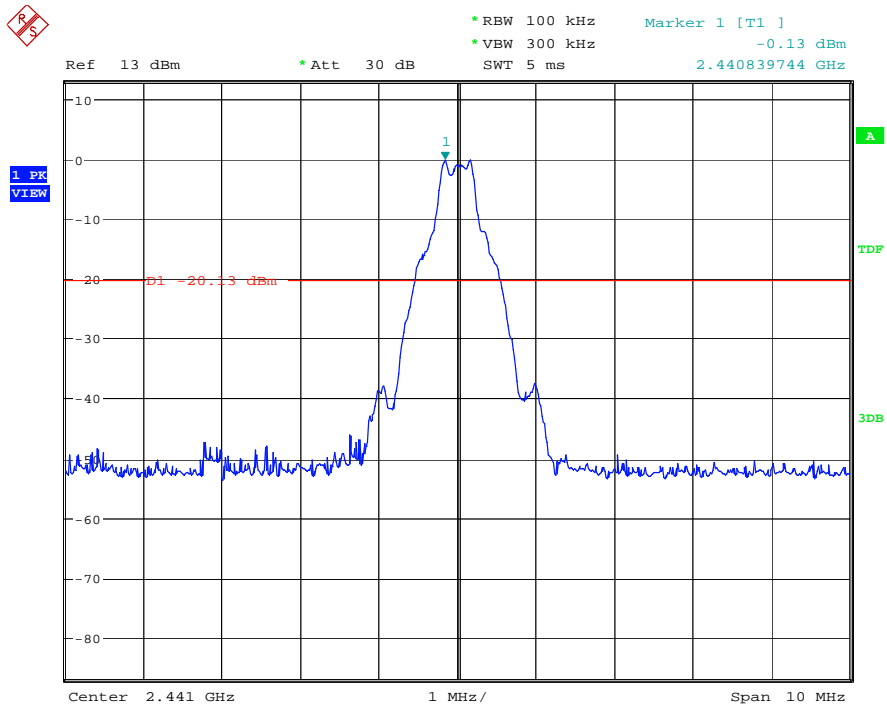

High Channel



*RBW 100 kHz Marker 2 [T1]
 *VBW 300 kHz -50.62 dBm
 SWT 5 ms 2.483500000 GHz

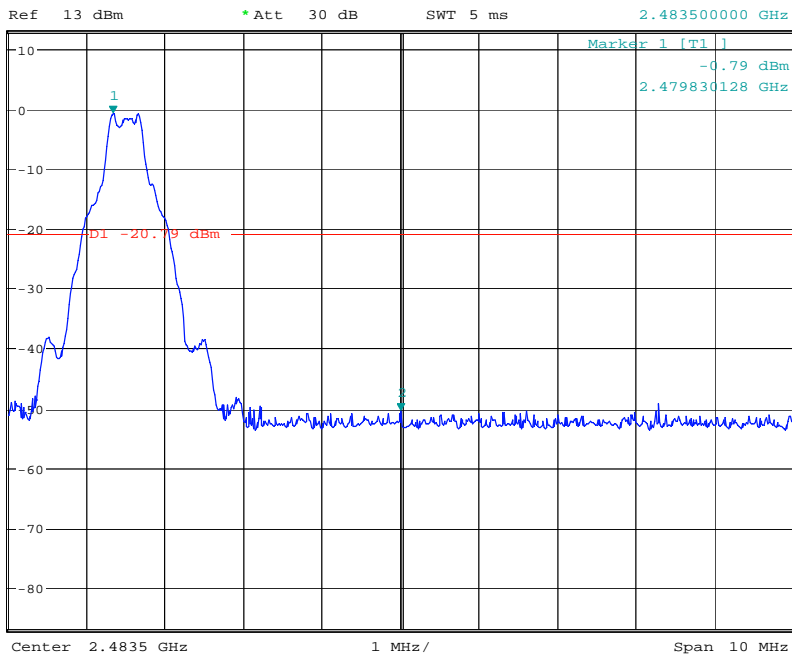

*RBW 100 kHz Marker 2 [T1]
 *VBW 300 kHz -46.89 dBm
 SWT 2.5 s 24.399759615 GHz

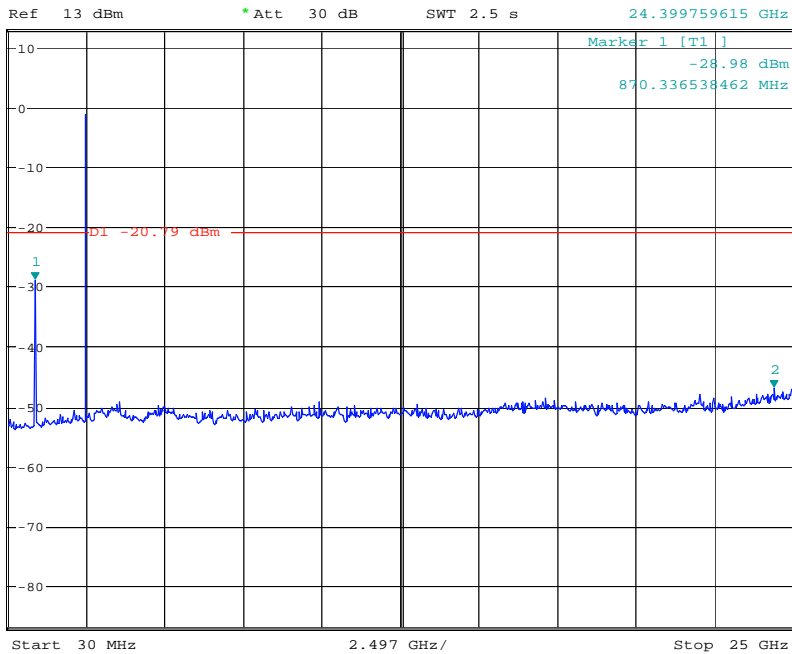

Bandedge at Hopping

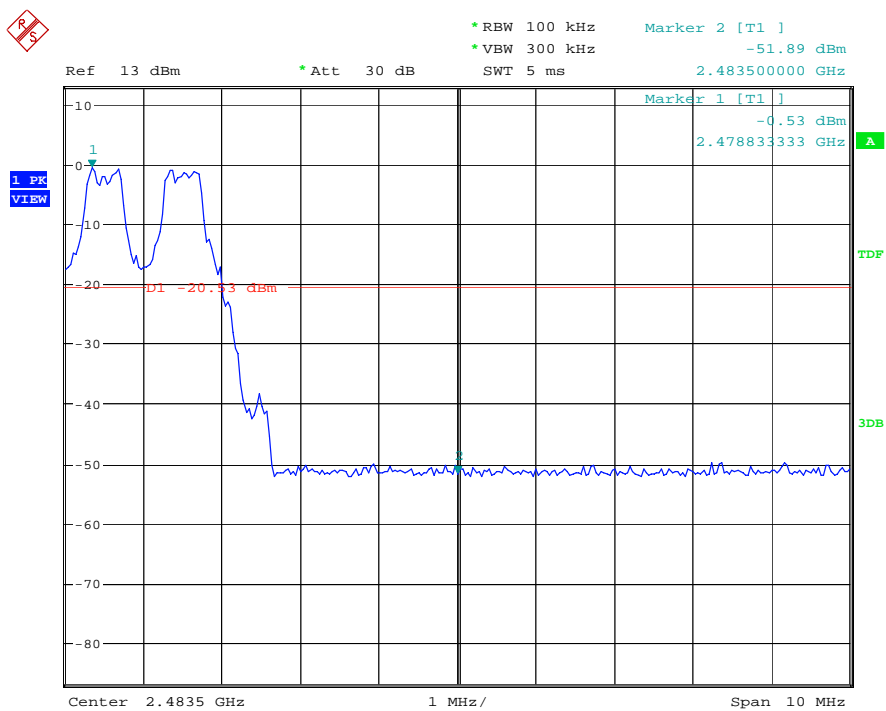
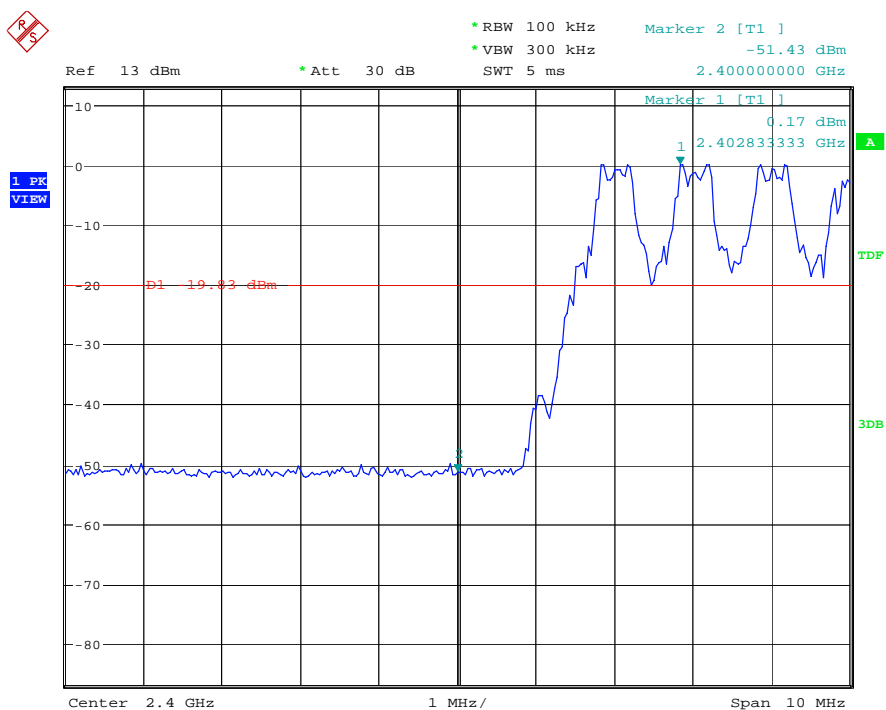

Operating Mode: 8DPSK(3 Mbps)

Low Channel

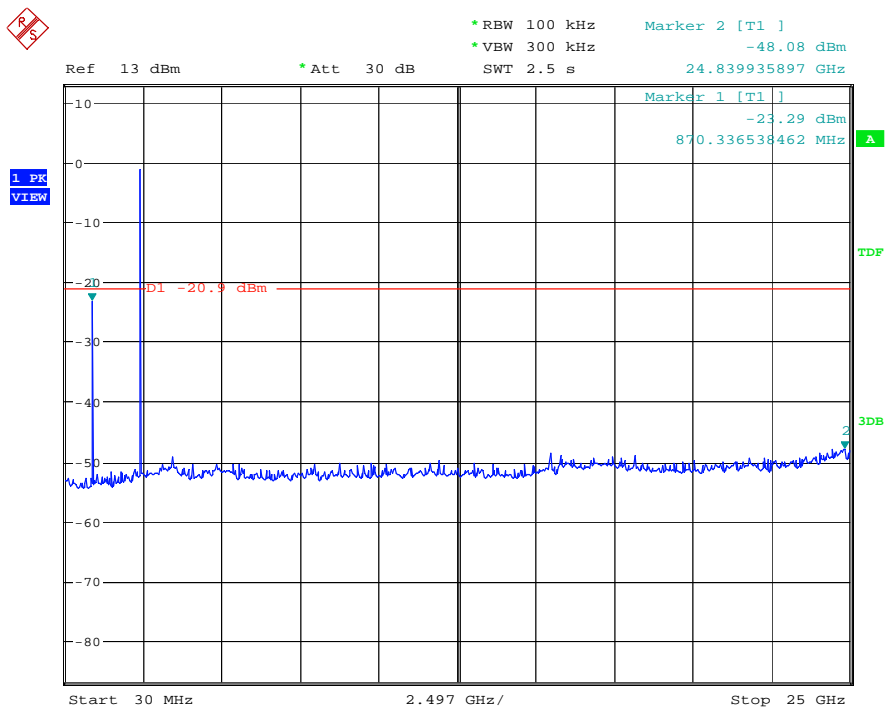
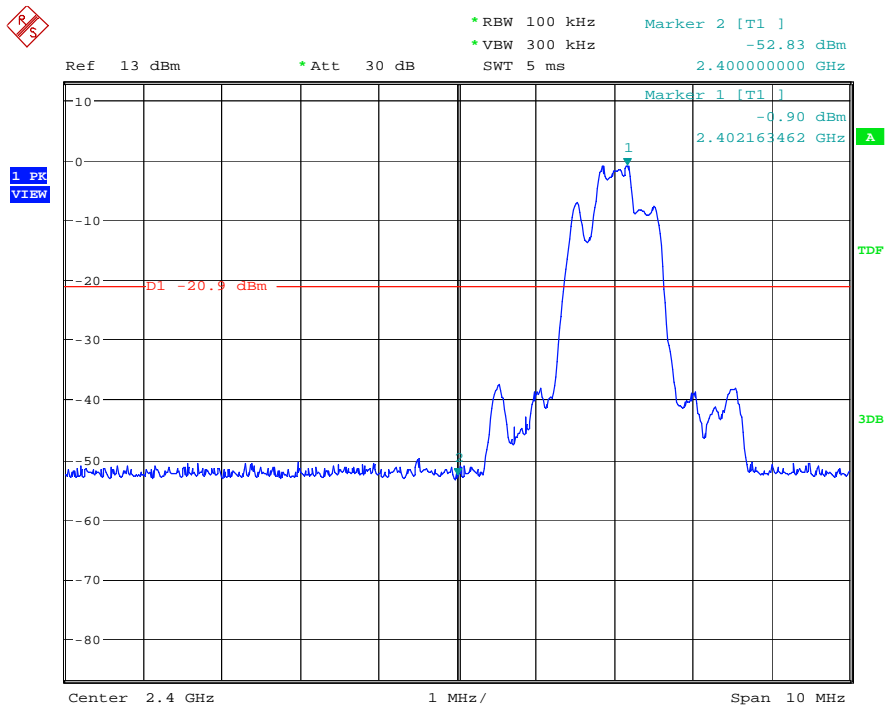

Middle Channel

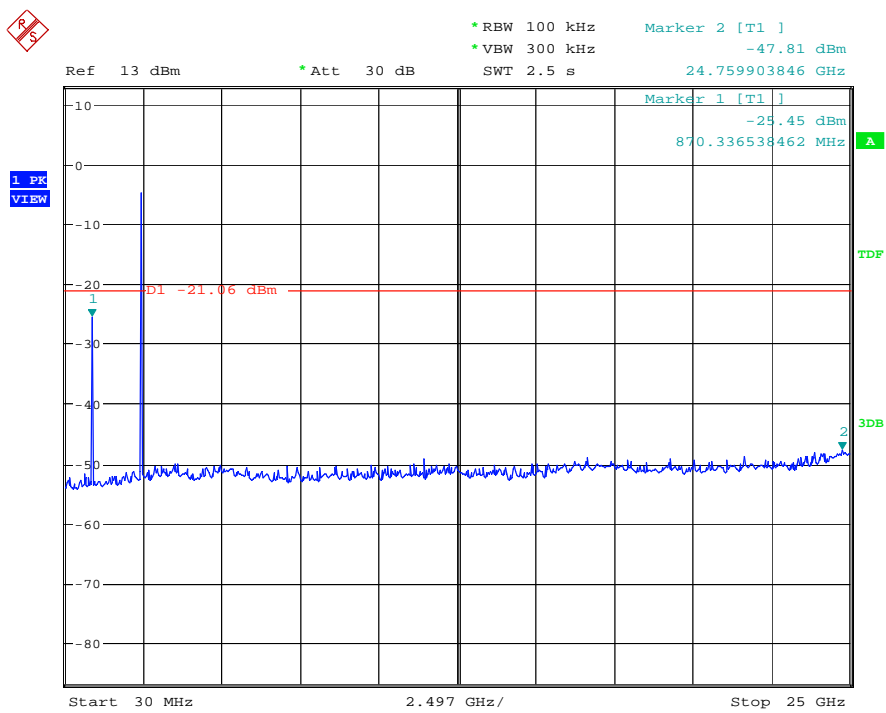
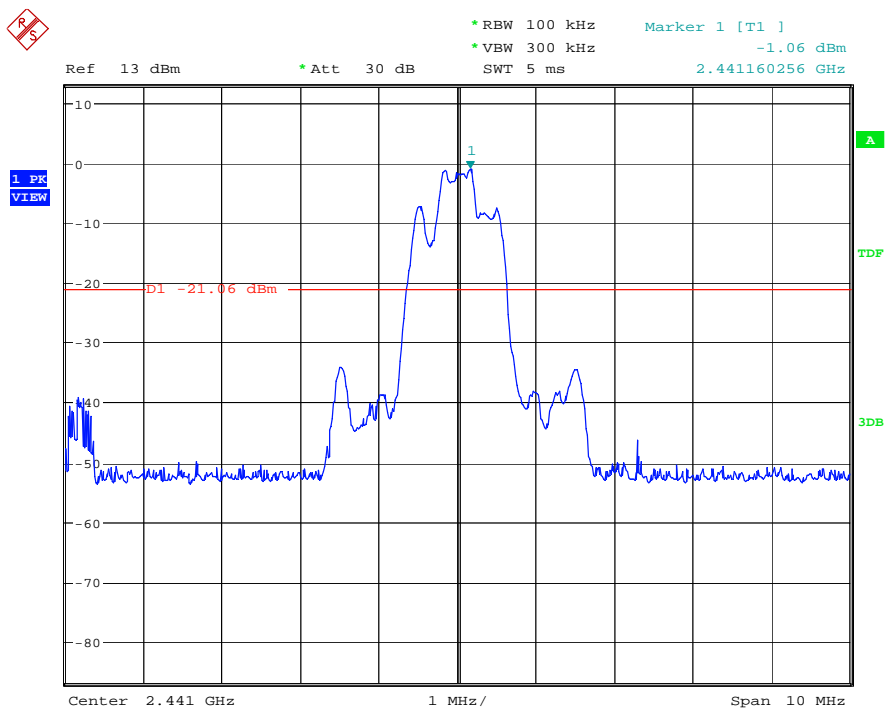

High Channel



*RBW 100 kHz Marker 2 [T1]
 *VBW 300 kHz -52.69 dBm
 SWT 5 ms 2.483500000 GHz

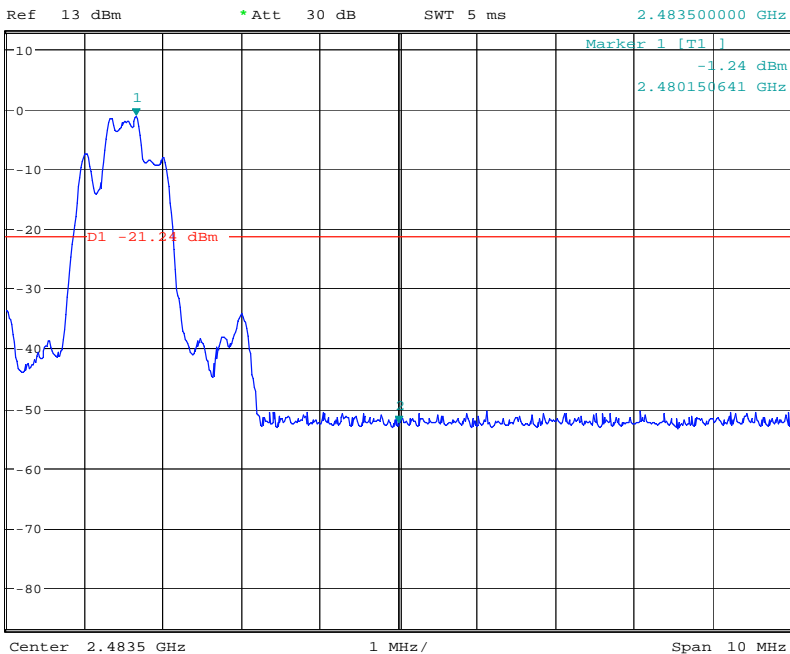

*RBW 100 kHz Marker 2 [T1]
 *VBW 300 kHz -47.59 dBm
 SWT 2.5 s 24.679871795 GHz

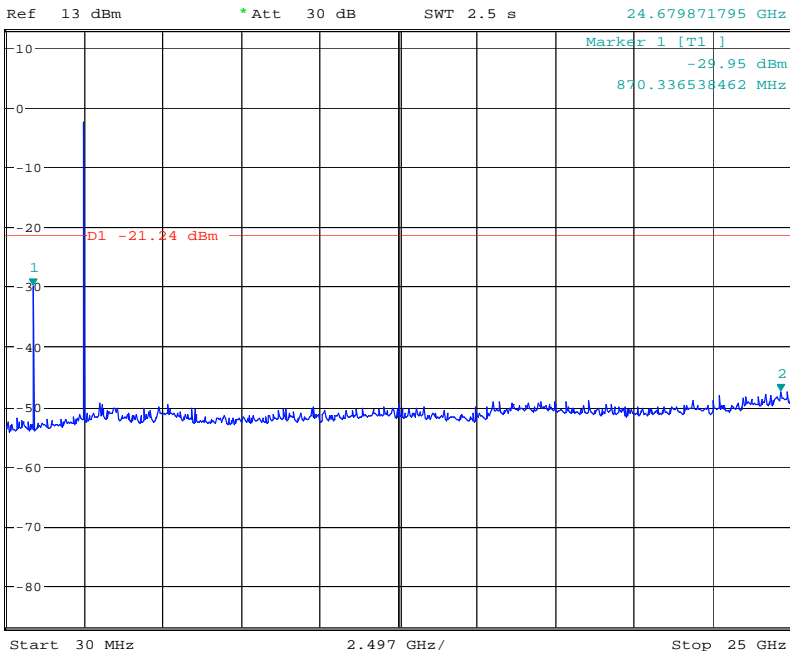

Bandedge at Hopping

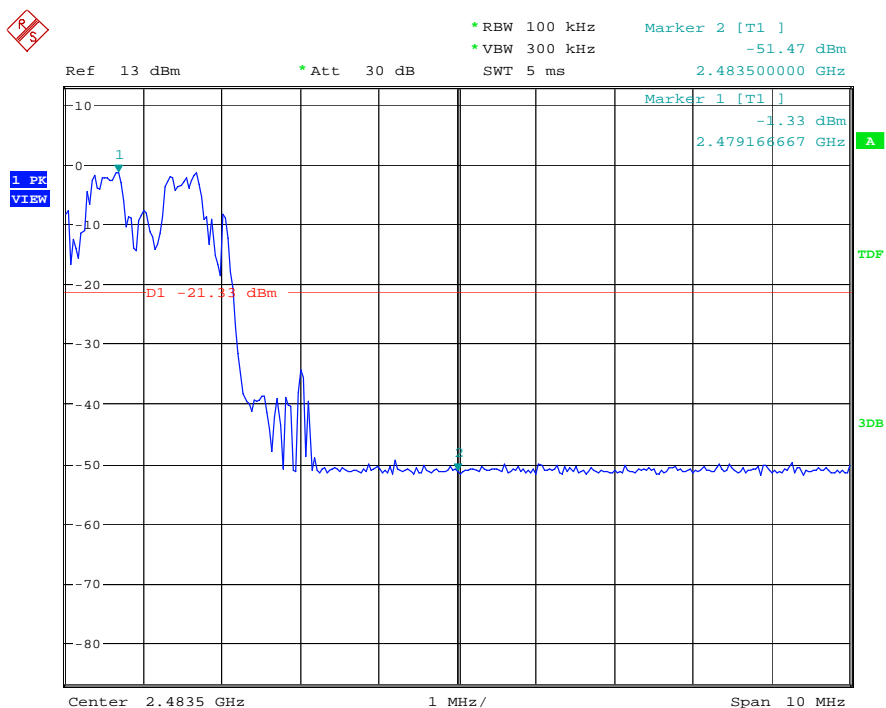
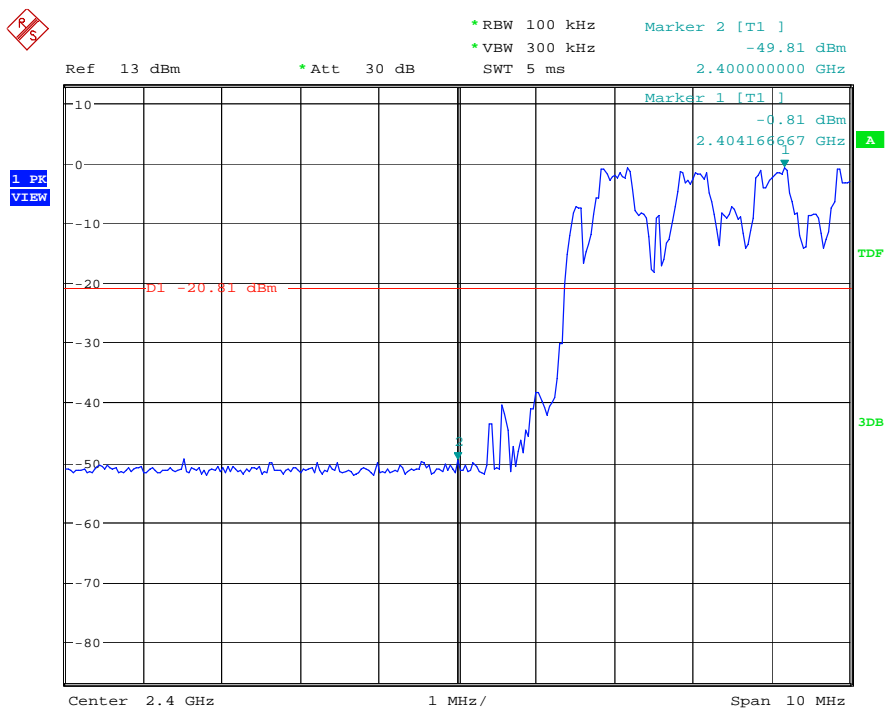

6. NUMBER OF HOPPING CHANNEL**6.1 APPLIED PROCEDURES / LIMIT**

FCC Part15 (15.247) , Subpart C				
Section	Test Item	Limit	Frequency Range (MHz)	Result
15.247 (a)(1)(iii)	Number of Hopping Channel	≥15	2400-2483.5	PASS

Spectrum Parameters	Setting
Attenuation	Auto
Span Frequency	> Operating Frequency Range
RB	1MHz
VB	3MHz
Detector	Peak
Trace	Max Hold
Sweep Time	Auto

6.2 TEST PROCEDURE

- a. Remove the antenna from the EUT and then connect a low loss RF cable from the antenna port to the spectrum analyzer.
- b. Spectrum Setting: RBW= 1MHz, VBW=3MHz, Sweep time = Auto.

6.3 DEVIATION FROM STANDARD

No deviation.

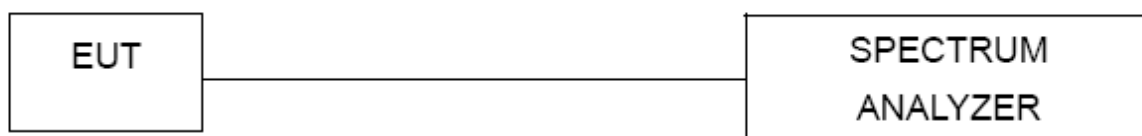
6.4 TEST SETUP**6.5 EUT OPERATION CONDITIONS**

The EUT tested system was configured as the statements of 2.4 Unless otherwise a special operating condition is specified in the follows during the testing.

6.6 TEST RESULTS

EUT	multimedia speaker	Model Name	SPME51
Temperature	25 °C	Relative Humidity	60%
Pressure	1015 hPa	Test Date	August 15, 2015
Test Mode	Hopping Mode	Number of Hopping Channel	79

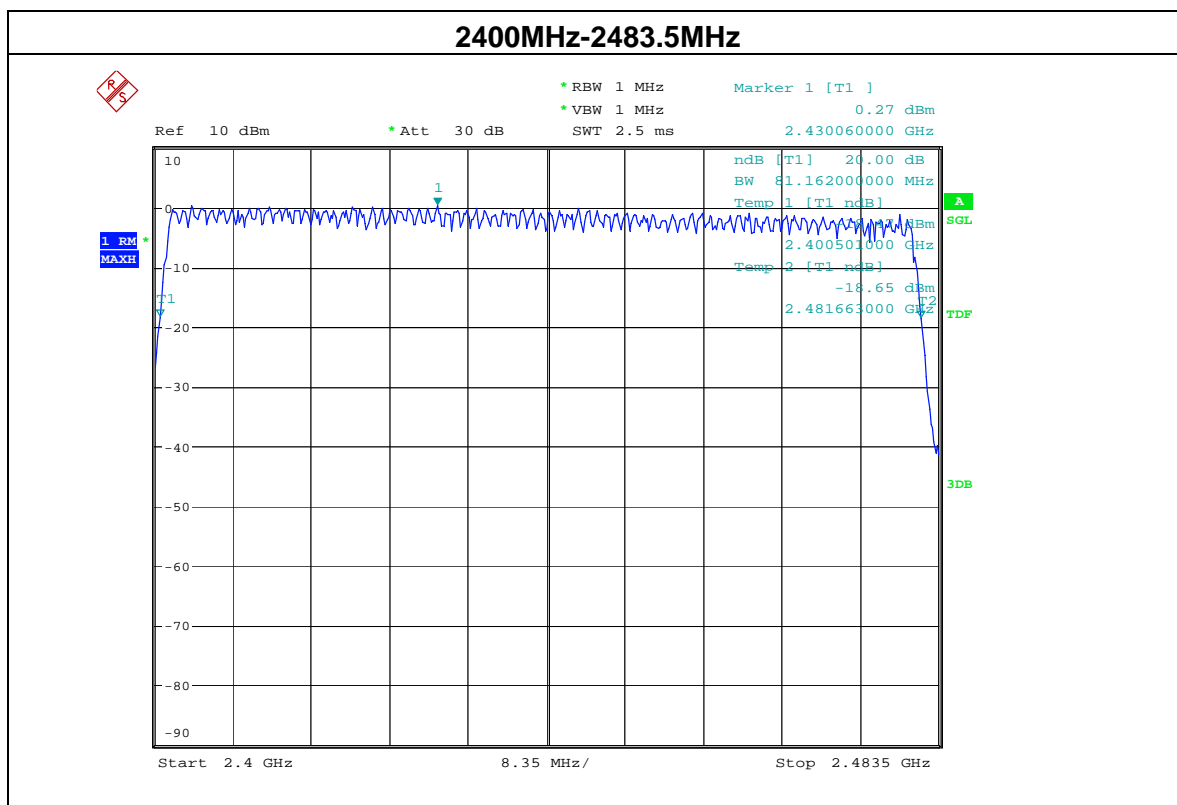

7. AVERAGE TIME OF OCCUPANCY**7.1 APPLIED PROCEDURES / LIMIT**

FCC Part15 (15.247) , Subpart C				
Section	Test Item	Limit	Frequency Range (MHz)	Result
15.247 (a)(1)(iii)	Average Time of Occupancy	0.4sec	2400-2483.5	PASS

7.2 TEST PROCEDURE

- a. Remove the antenna from the EUT and then connect a low loss RF cable from the antenna port to the spectrum analyzer.
- b. Set RBW of spectrum analyzer to 1MHz and VBW to 3MHz.
- c. Use a video trigger with the trigger level set to enable triggering only on full pulses.
- d. Sweep Time is more than once pulse time.
- e. Set the center frequency on any frequency would be measure and set the frequency span to zero span.
- f. Measure the maximum time duration of one single pulse.
- g. Set the EUT for DH5, DH3 and DH1 packet transmitting.
- h. Measure the maximum time duration of one single pulse.
- i. DH1 Dwell time = Pulse time*(1600/2/79)*31.6S
DH3 Dwell time = Pulse time*(1600/4/79)*31.6S
DH5 Dwell time = Pulse time*(1600/6/79)*31.6S

7.3 DEVIATION FROM STANDARD

No deviation.

7.4 TEST SETUP



7.5 EUT OPERATION CONDITIONS

The EUT tested system was configured as the statements of 2.4 Unless otherwise a special operating condition is specified in the follows during the testing.

7.6 TEST RESULTS

Note: *the worst case is DH5-3Mbps as result in this part.*

EUT	multimedia speaker	Model Name	SPME51
Temperature	25 °C	Relative Humidity	60%
Pressure	1012 hPa	Test Date	August 15, 2015
Test Mode	DH5-3Mbps		

Data Packet	Frequency	Pulse time(ms)	Dwell Time(S)	Limits (S)
DH5	2402MHz	3.0023	0.320	0.4
DH5	2441MHz	3.0025	0.320	0.4
DH5	2480MHz	3.0025	0.320	0.4

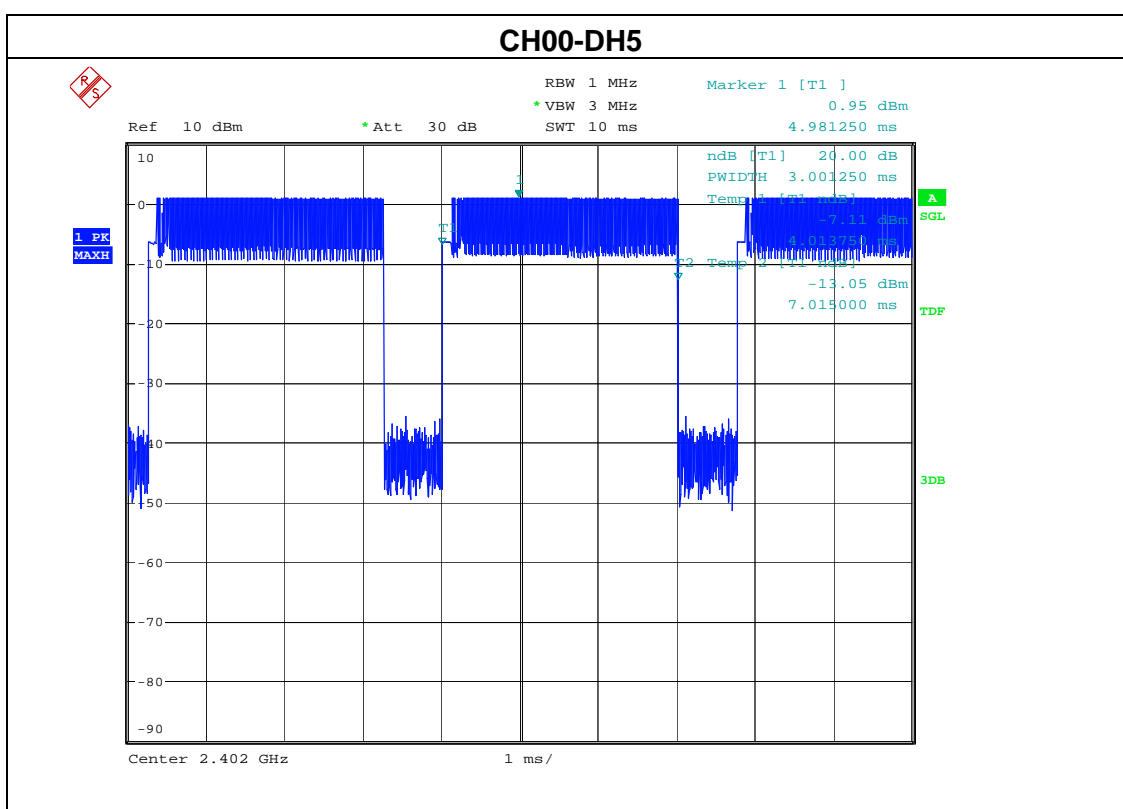

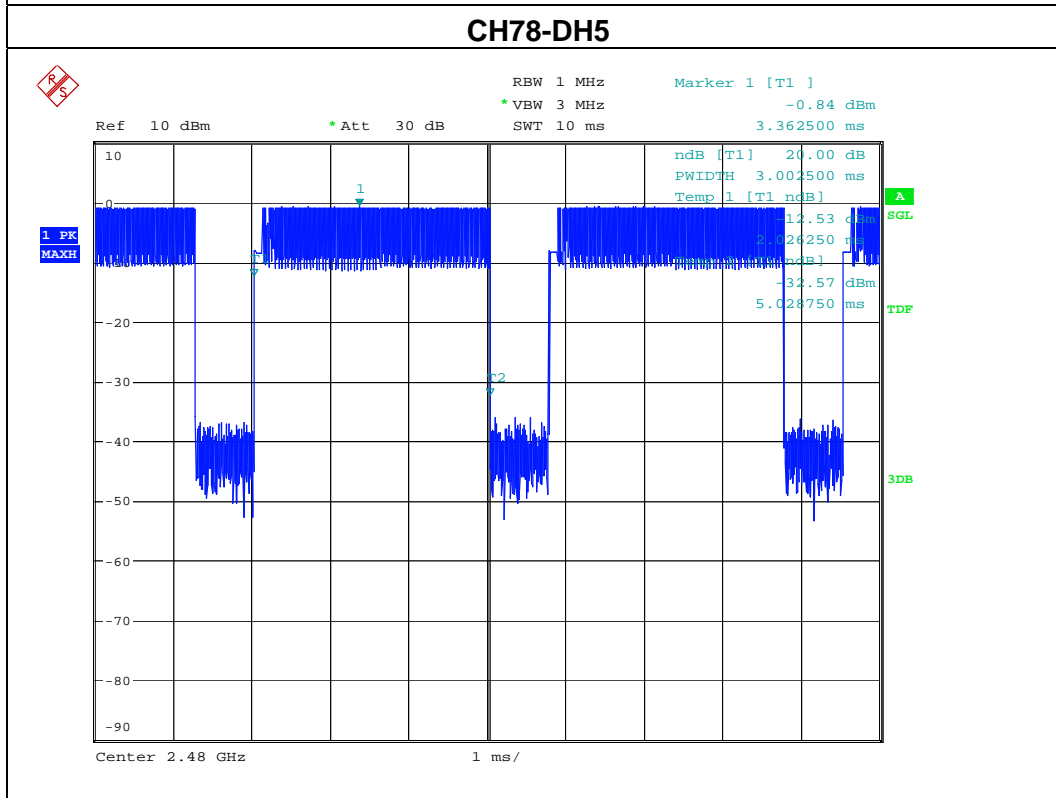
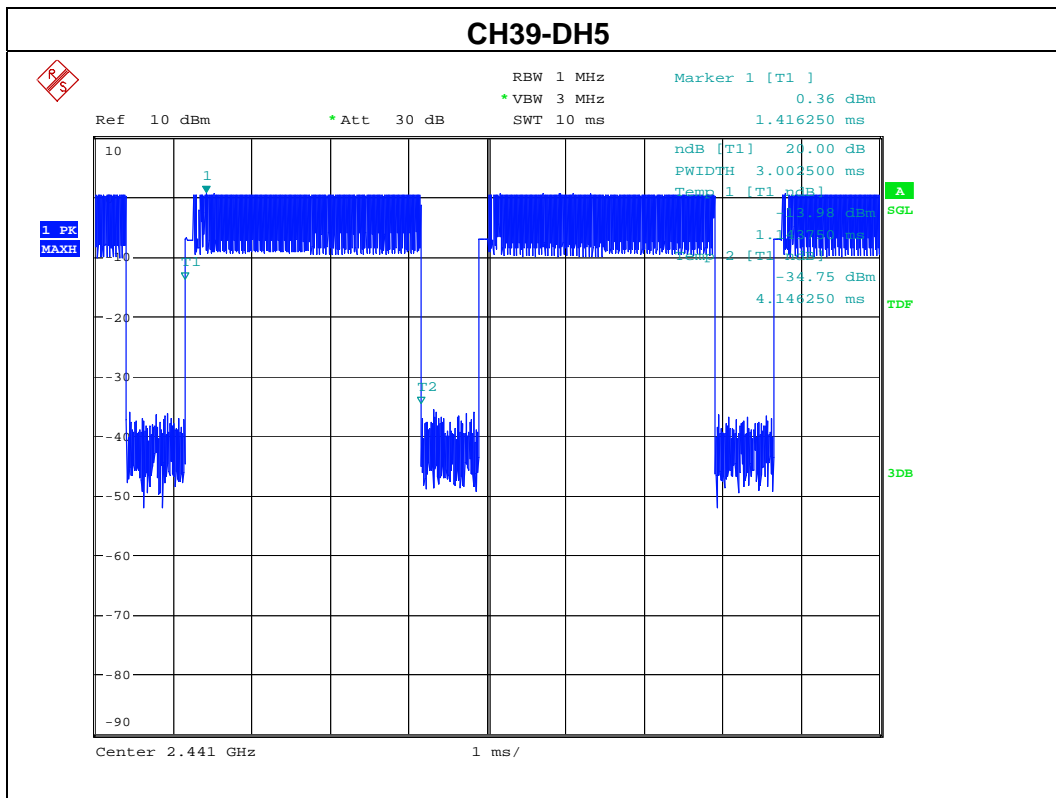

8. HOPPING CHANNEL SEPARATION MEASUREMENT

8.1 APPLIED PROCEDURES / LIMIT

Frequency hopping systems operating in the 2400-2483.5 MHz band may have hopping channel carrier frequencies that are separated by 25 kHz or two-thirds of the 20 dB bandwidth of the hopping channel, whichever is greater.

Spectrum Parameter	Setting
Attenuation	Auto
Span Frequency	> Measurement Bandwidth or Channel Separation
RB	Resolution (or IF) Bandwidth (RBW) \geq 1% of the span
VB	Video (or Average) Bandwidth (VBW) \geq RBW
Detector	Peak
Trace	Max hold
Sweep Time	Auto

8.2 TEST PROCEDURE

1. Check the calibration of the measuring instrument using either an internal calibrator or a known signal from an external generator.
3. Remove the antenna from the EUT and then connect a low loss RF cable from the antenna port to the spectrum analyzer.
4. Set the spectrum analyzer as follows: Span = wide enough to capture the peaks of two adjacent channels: Resolution (or IF) Bandwidth (RBW) \geq 1% of the span; Video (or Average) Bandwidth (VBW) \geq RBW; Sweep = auto; Detector function = peak; Trace = max hold
5. Measure the separation between the peaks of the adjacent channels using the marker-delta function.
6. Repeat above procedures until all frequencies measured were complete.

8.3 DEVIATION FROM STANDARD

No deviation.

8.4 TEST SETUP

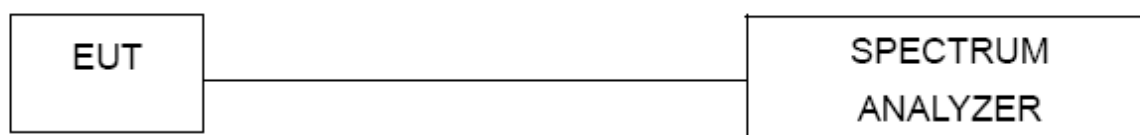

8.5 EUT OPERATION CONDITIONS

The EUT was programmed to be in continuously transmitting mode.

8.6 TEST RESULTS

EUT	MULTIMEDIA SPEAKER	Model Name	SPME51
Temperature	25 °C	Relative Humidity	60%
Pressure	1012 hPa	Test Result	Pass
Test Mode	CH00 / CH39 /CH78 (1Mbps Mode)	Test Date	August 15, 2015

Channel number	Channel frequency (MHz)	Separation Read value (KHz)	Separation limit 2/3 20db down BW(KHz)
00	2402	1005	>696.00
39	2441	990	>700.00
78	2480	1005	>700.00

Note: 20db bandwidth refer to section 6.1.5

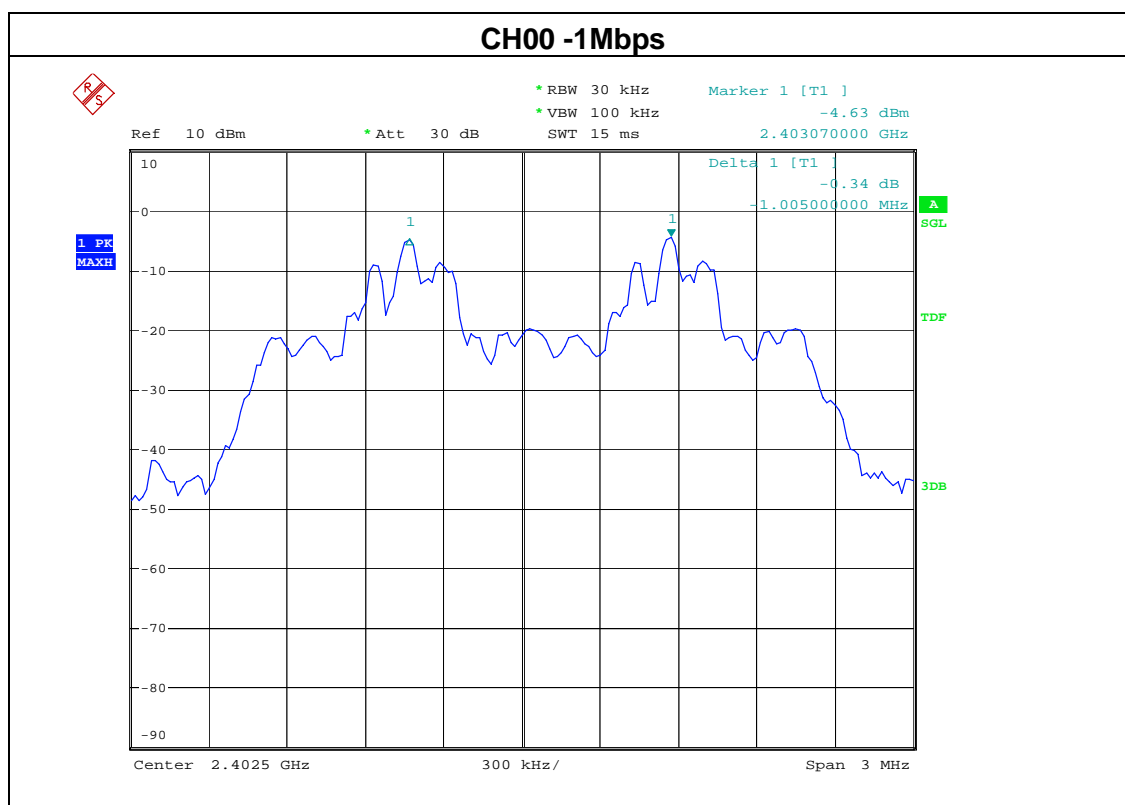

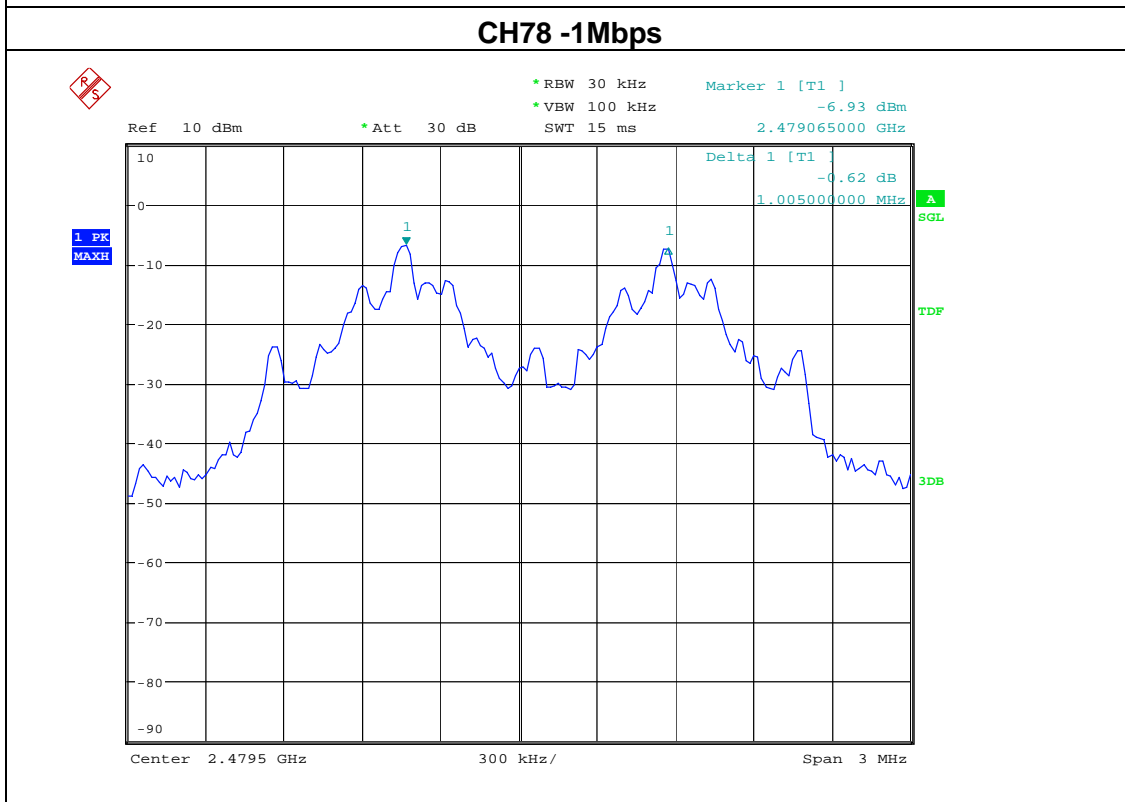
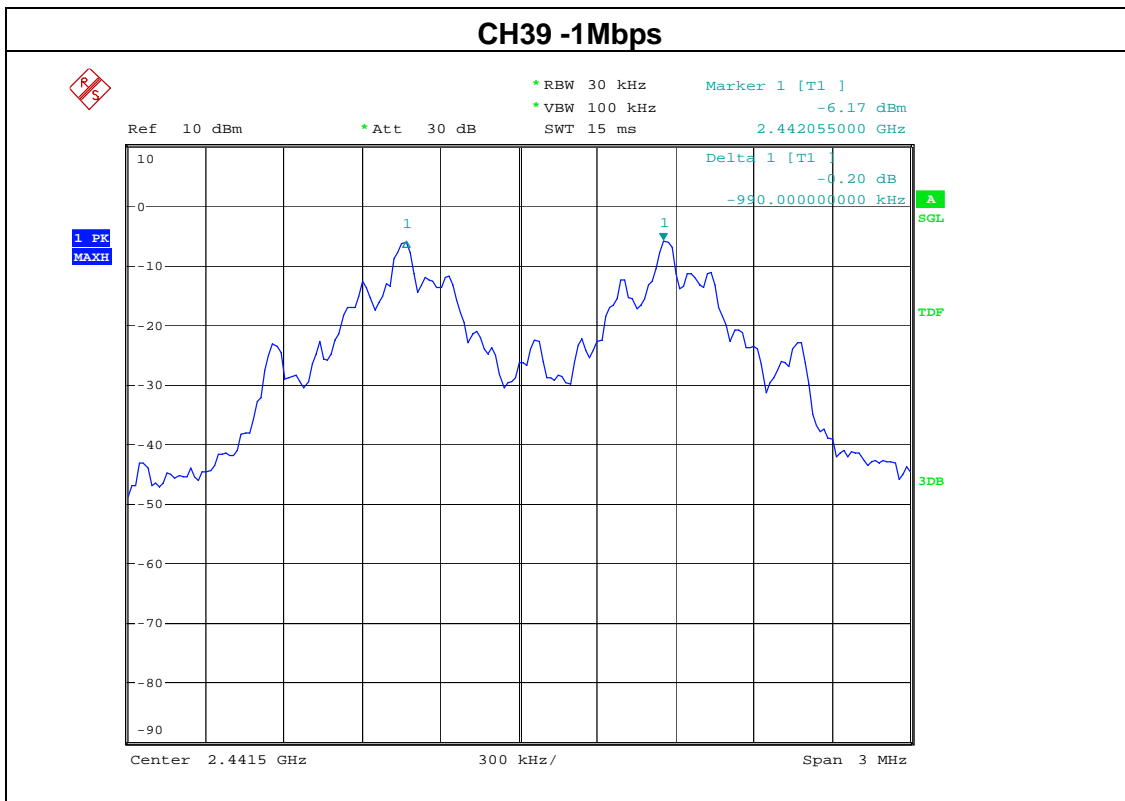

EUT	multimedia speaker	Model Name	SPME51
Temperature	25 °C	Relative Humidity	60%
Pressure	1012 hPa	Test Result	Pass
Test Mode	CH00 / CH39 /CH78 (2Mbps Mode)	Test Date	August 15, 2015

Channel number	Channel frequency (MHz)	Separation Read value (KHz)	Separation limit 2/3 20db down BW(KHz)
00	2402	1005	>732.00
39	2441	1005	>732.00
78	2480	1005	>732.00

Note: 20db bandwidth refer to section 6.1.5

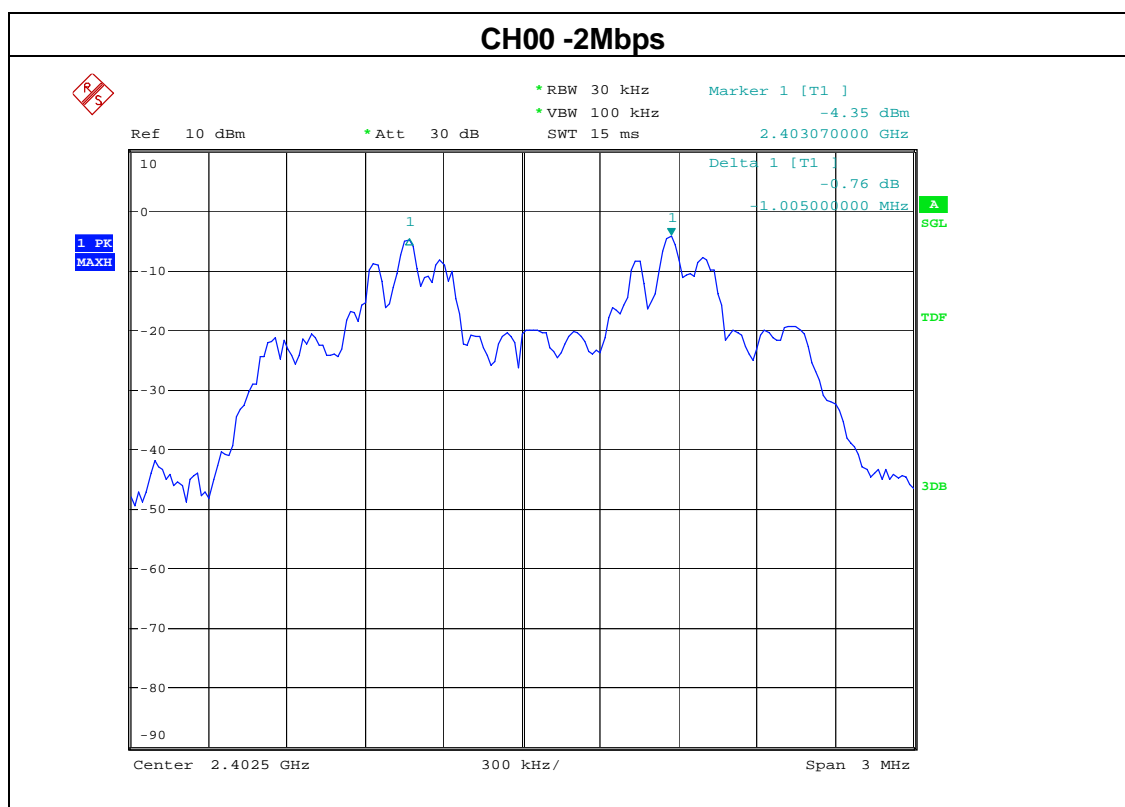

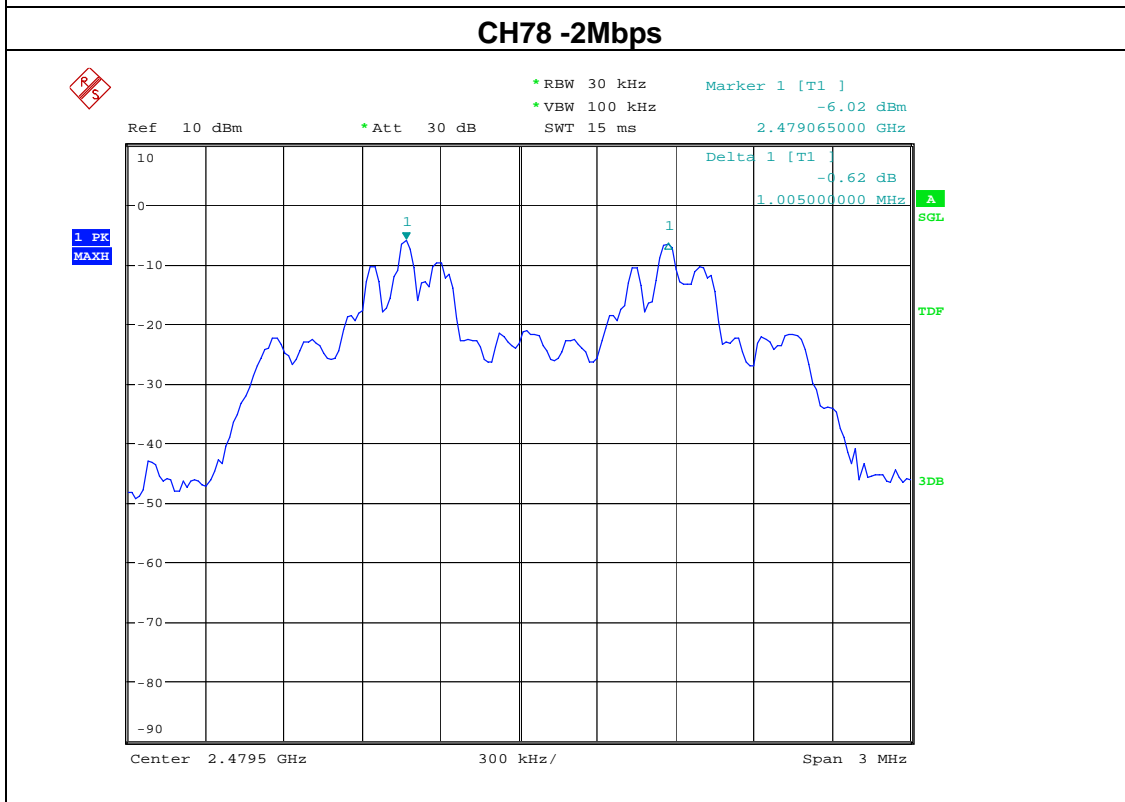
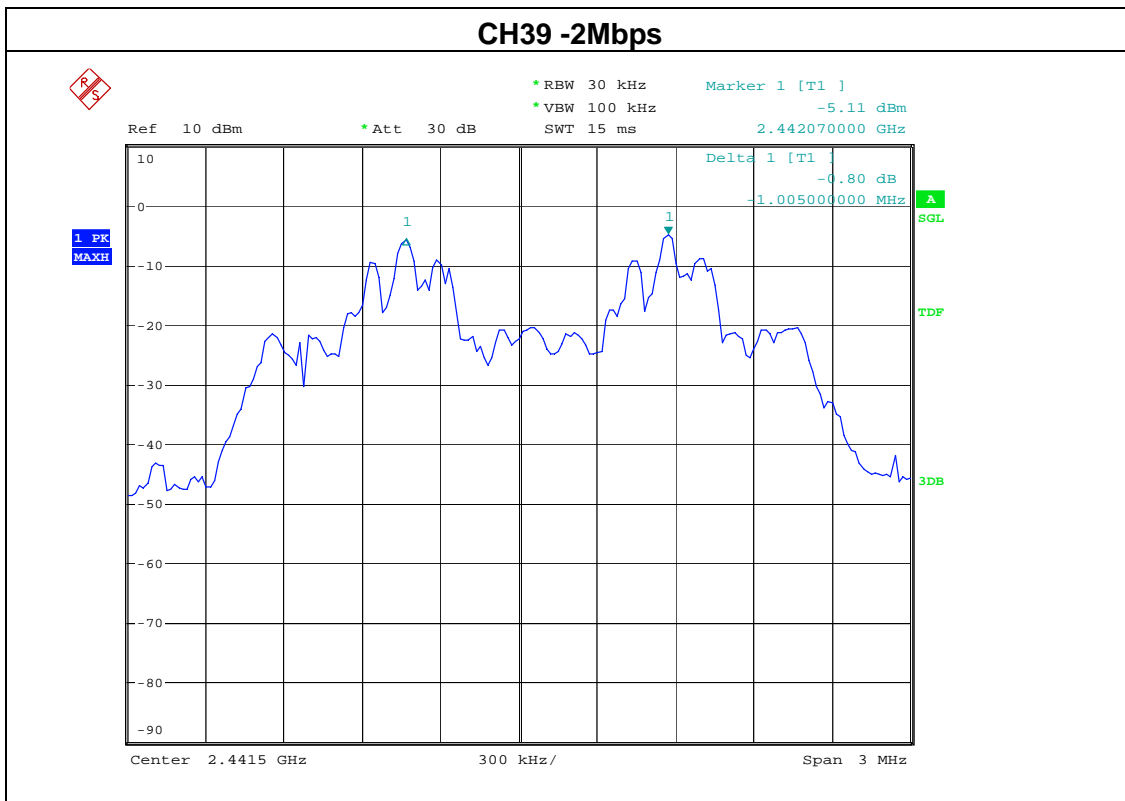

EUT	multimedia speaker	Model Name	SPME51
Temperature	25 °C	Relative Humidity	60%
Pressure	1012 hPa	Test Result	Pass
Test Mode	CH00 / CH39 /CH78 (3Mbps Mode)	Test Date	August 15, 2015

Channel number	Channel frequency (MHz)	Separation Read value (KHz)	Separation limit 2/3 20db down BW(KHz)
00	2402	1005	>756.00
39	2441	1005	>752.00
78	2480	990	>756.00

Note: 20db bandwidth refer to section 6.1.5

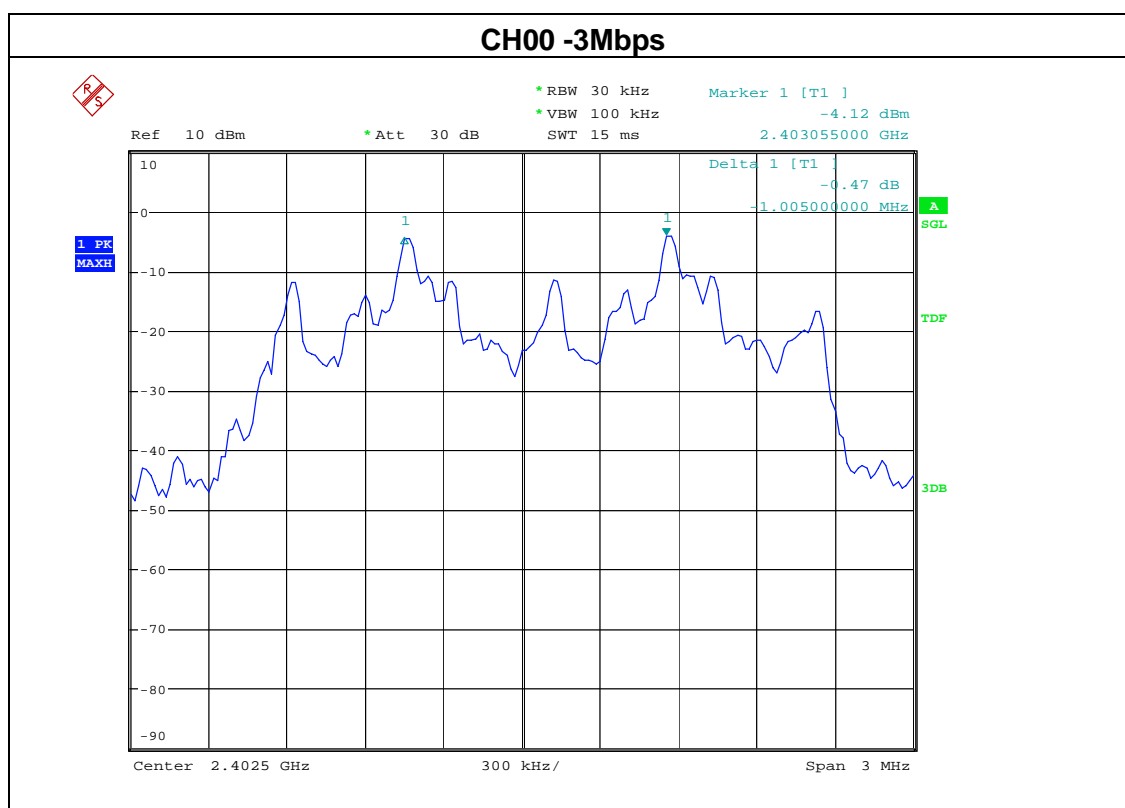

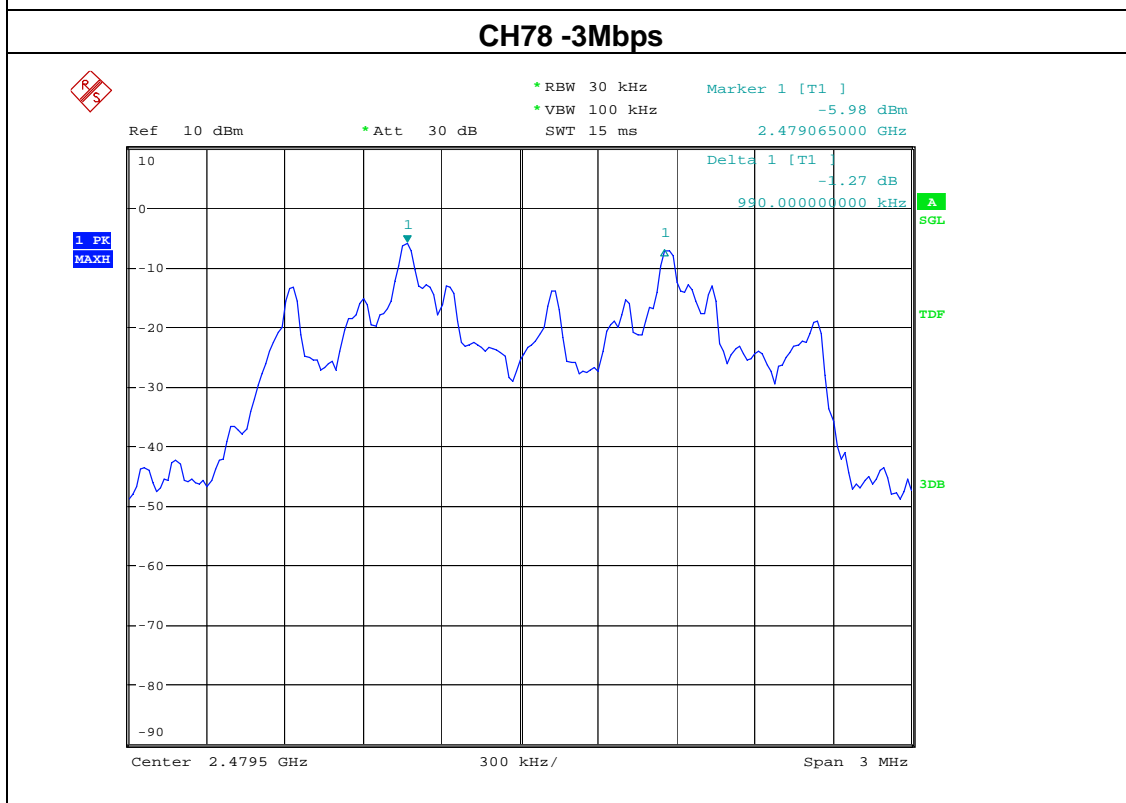
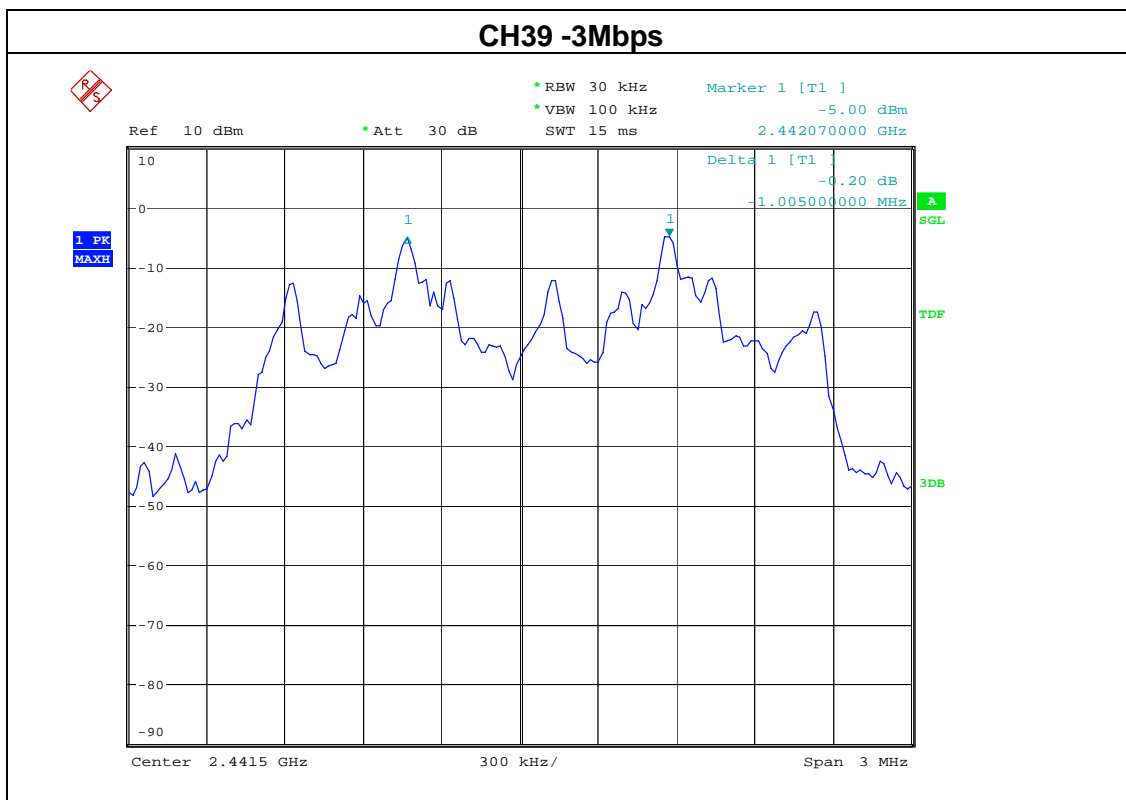

9. BANDWIDTH TEST**9.1 APPLIED PROCEDURES / LIMIT**

FCC Part15 (15.247) , Subpart C				
Section	Test Item	Limit	Frequency Range (MHz)	Result
15.247 (a)(1)	Bandwidth	(20dB bandwidth)	2400-2483.5	PASS

Spectrum Parameter	Setting
Attenuation	Auto
Span Frequency	> Measurement Bandwidth or Channel Separation
RB	30kHz
VB	100 kHz
Detector	Peak
Trace	Max hold
Sweep Time	Auto

9.2 TEST PROCEDURE

1. Check the calibration of the measuring instrument (spectrum analyzer) using either an internal calibrator or a known signal from an external generator.
2. Remove the antenna from the EUT and then connect a low loss RF cable from the antenna port to the spectrum analyzer.
3. Set the spectrum analyzer as follows: VBW =30kHz, RBW=100kHz, Sweep = auto Detector function = peak ,Trace = max hold
4. Measure the highest amplitude appearing on spectral display and record the level to calculate results.
5. Repeat above procedures until all frequencies measured were complete.

9.3 DEVIATION FROM STANDARD

No deviation.

9.4 TEST SETUP**9.5 EUT OPERATION CONDITIONS**

The EUT tested system was configured as the statements of 2.4 Unless otherwise a special operating condition is specified in the follows during the testing.

9.6 TEST RESULTS

EUT	MULTIMEDIA SPEAKER	Model Name	SPME51
Temperature	25 °C	Relative Humidity	60%
Pressure	1012 hPa	Test Mode	CH00/CH39/C78(1Mbps)
Test Date	August 15, 2015		

Frequency	20dB Bandwidth (kHz)	Result
2402 MHz	1044	PASS
2441 MHz	1050	PASS
2480 MHz	1050	PASS

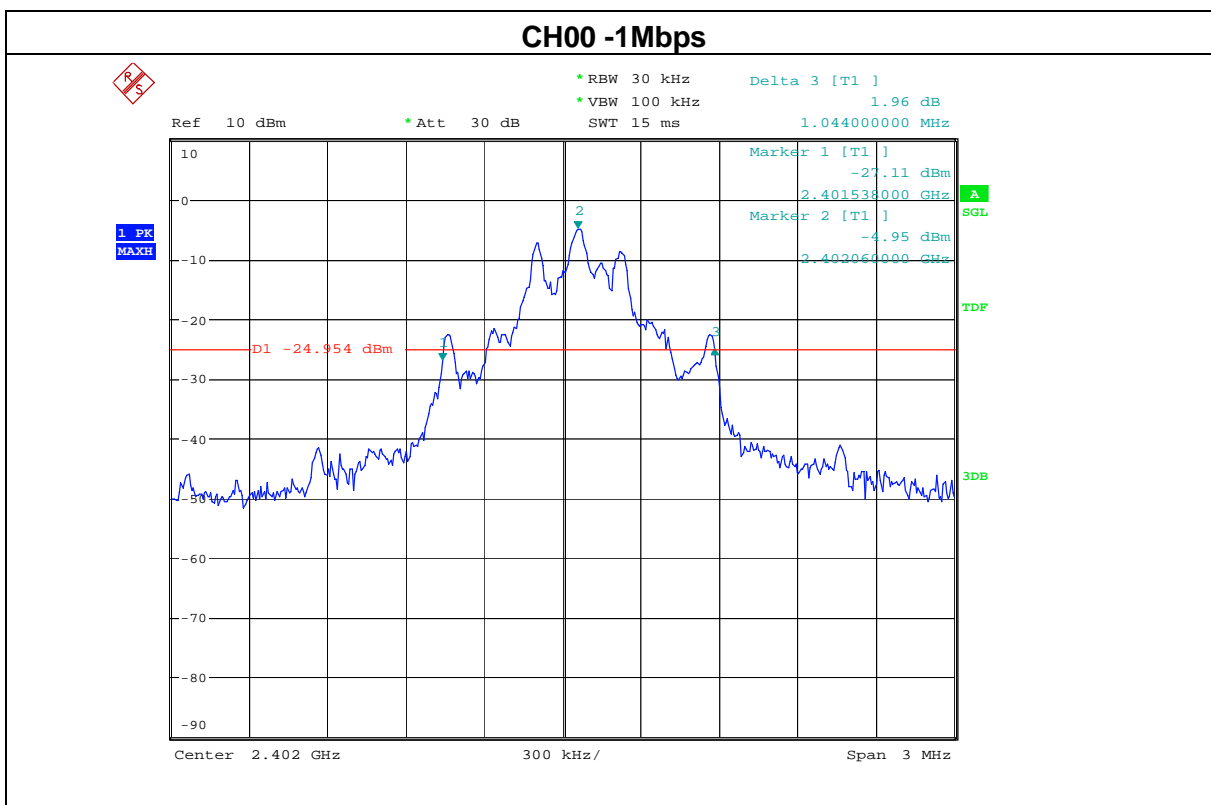

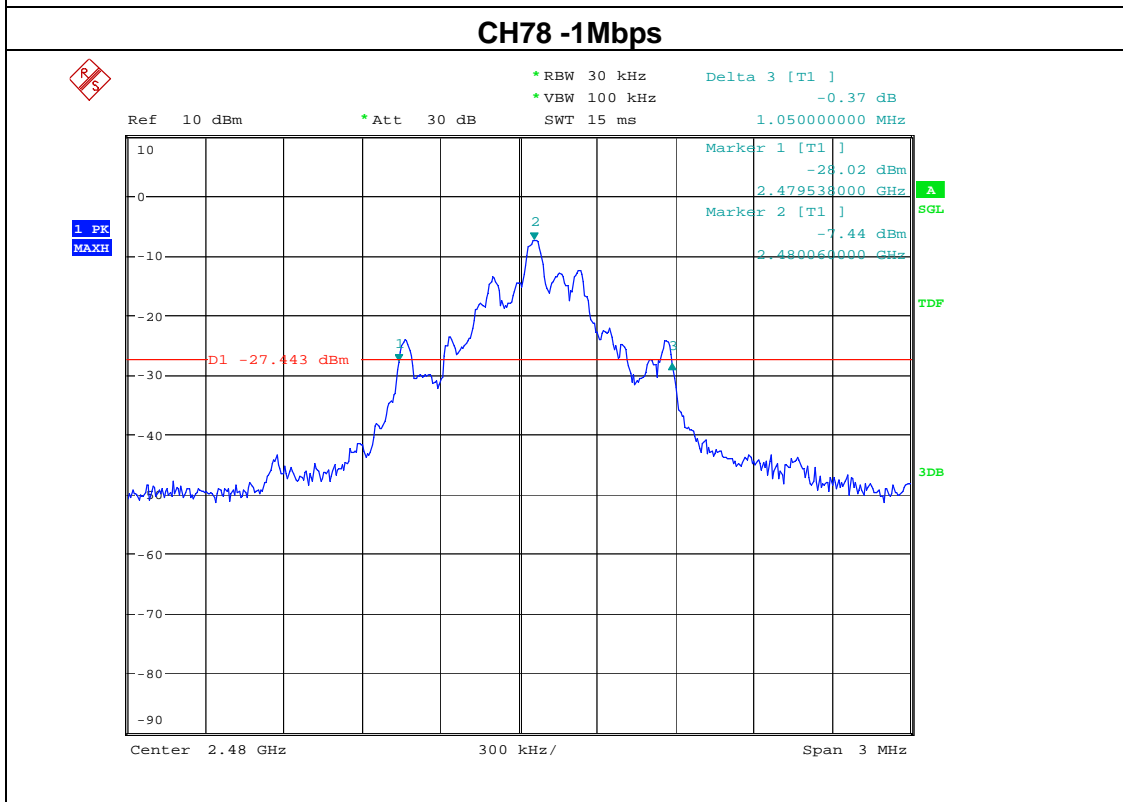
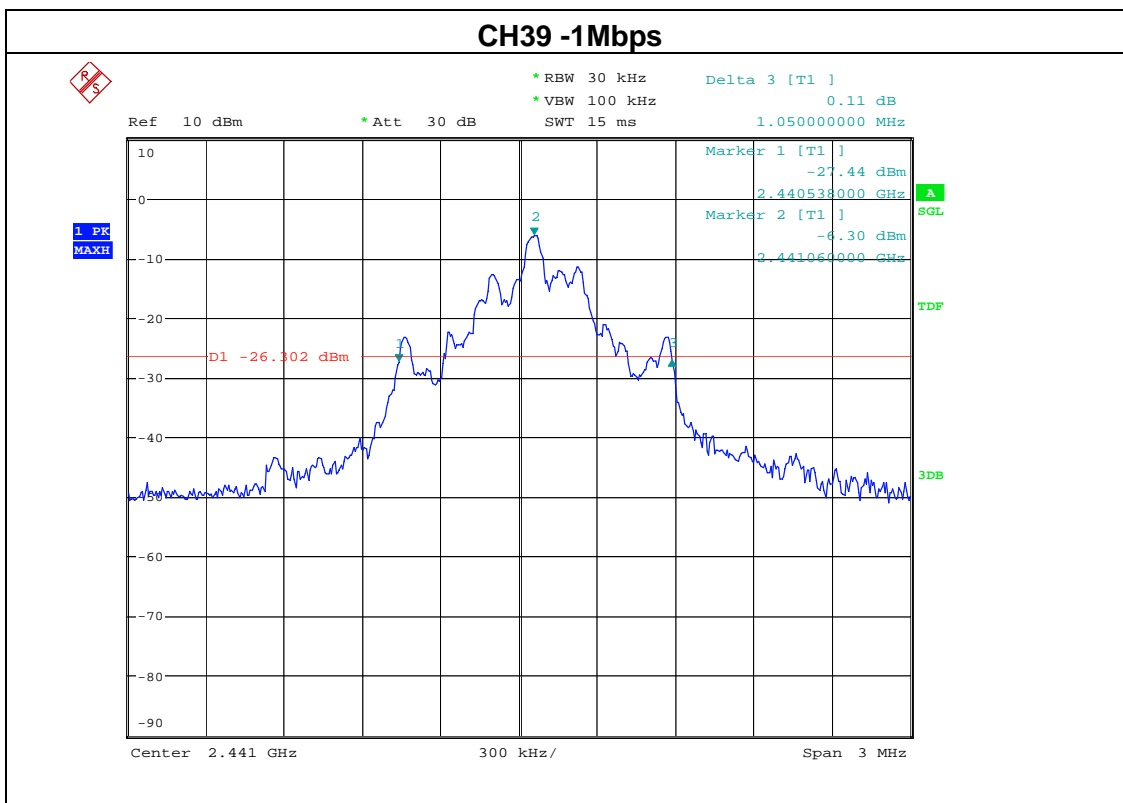

EUT	MULTIMEDIA SPEAKER	Model Name	SPME51
Temperature	25 °C	Relative Humidity	60%
Pressure	1012 hPa	Test Mode	CH00/CH39/C78(2Mbps)
Test Date	August 15, 2015		

Frequency	20dB Bandwidth (kHz)	Result
2402 MHz	1098	PASS
2441 MHz	1098	PASS
2480 MHz	1104	PASS

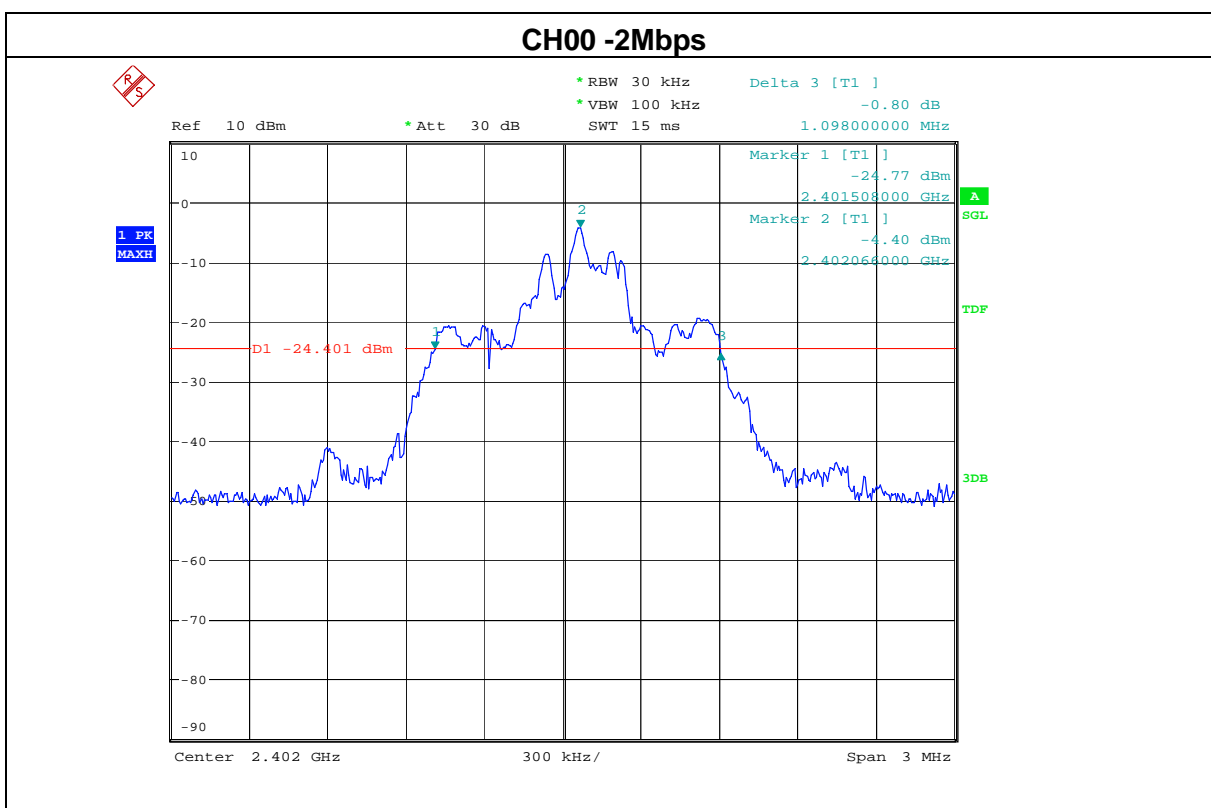

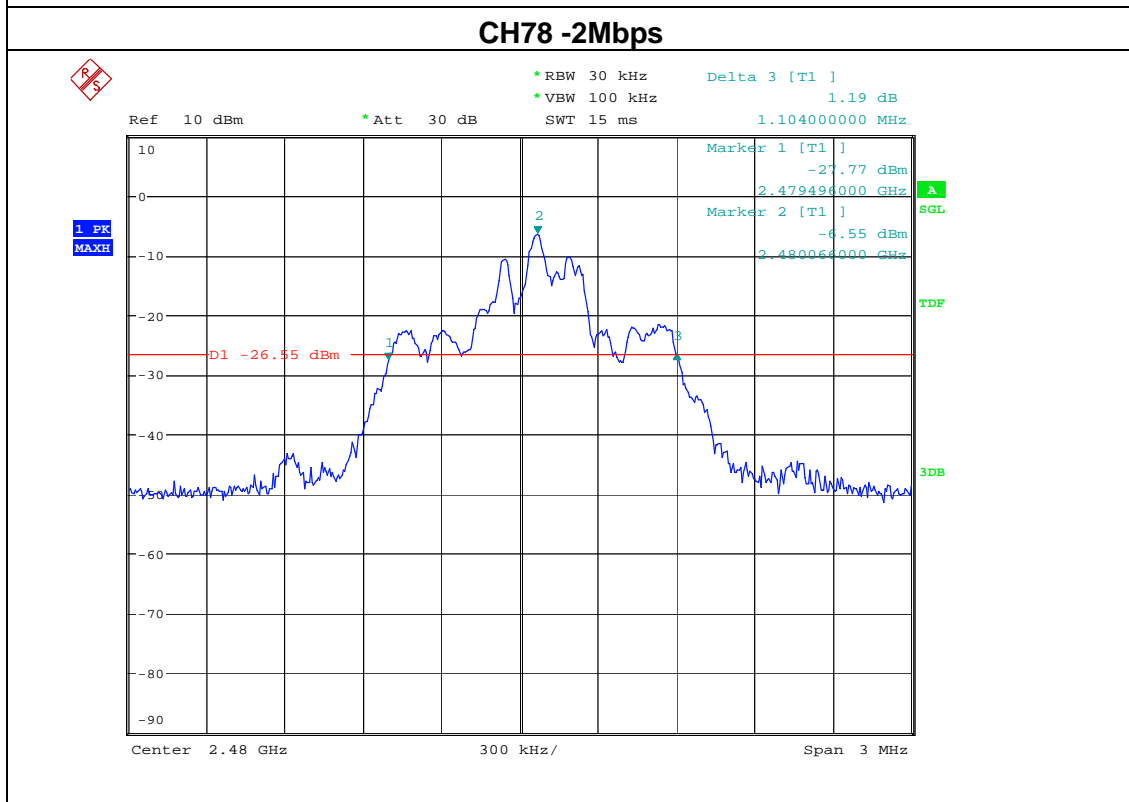
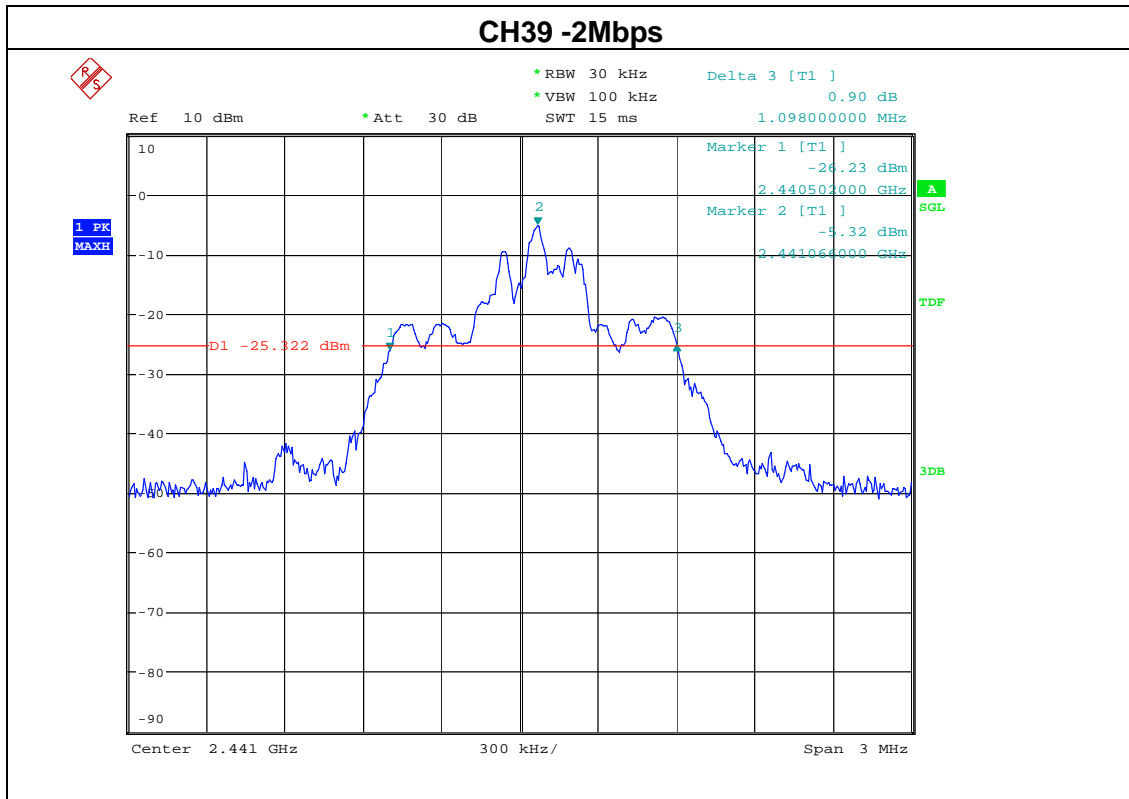

EUT	MULTIMEDIA SPEAKER	Model Name	SPME51
Temperature	25 °C	Relative Humidity	60%
Pressure	1012 hPa	Test Mode	CH00/CH39/C78(3Mbps)
Test Date	August 15, 2015		

Frequency	20dB Bandwidth (kHz)	Result
2402 MHz	1134	PASS
2441 MHz	1128	PASS
2480 MHz	1134	PASS

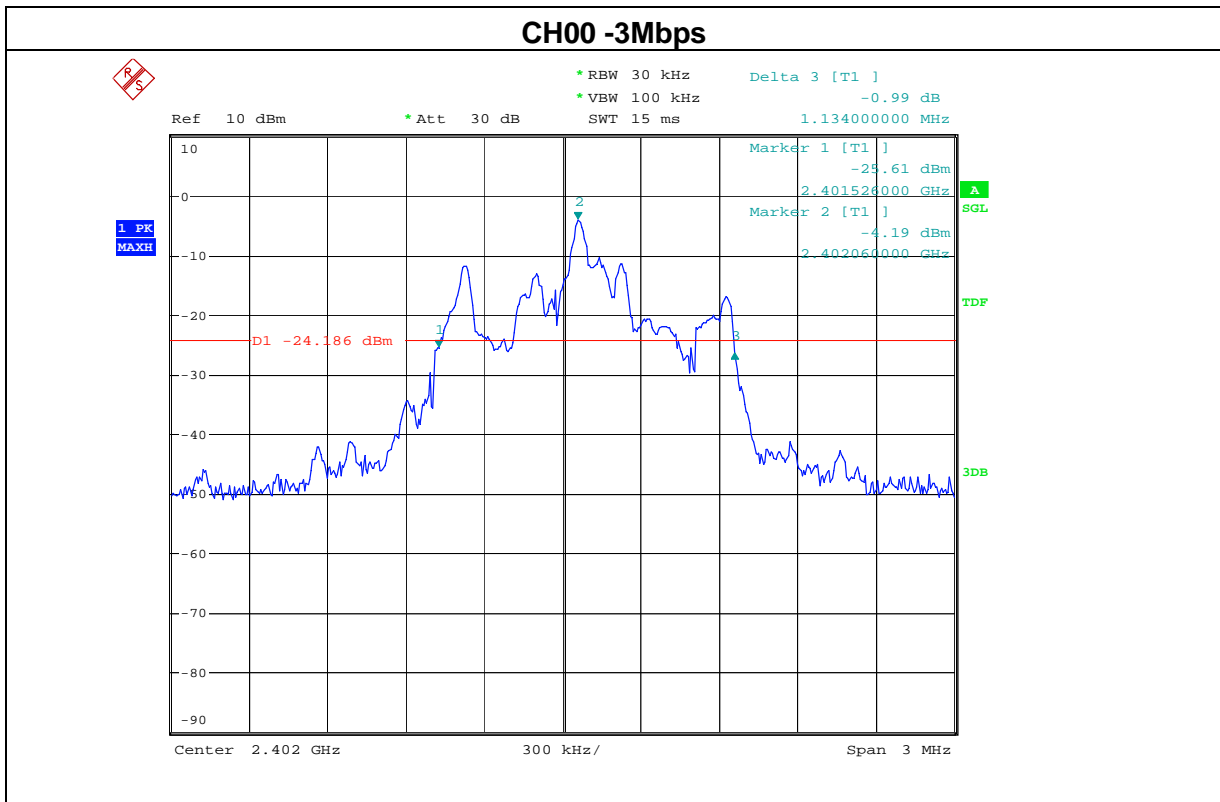

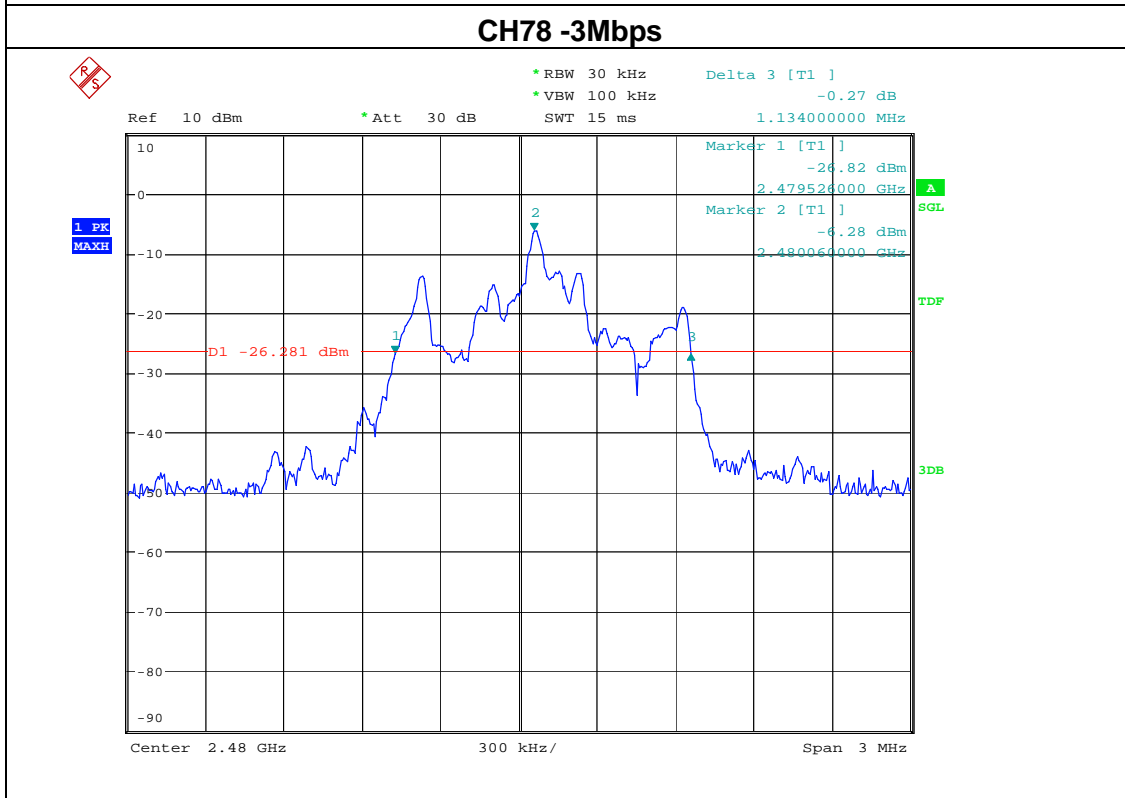
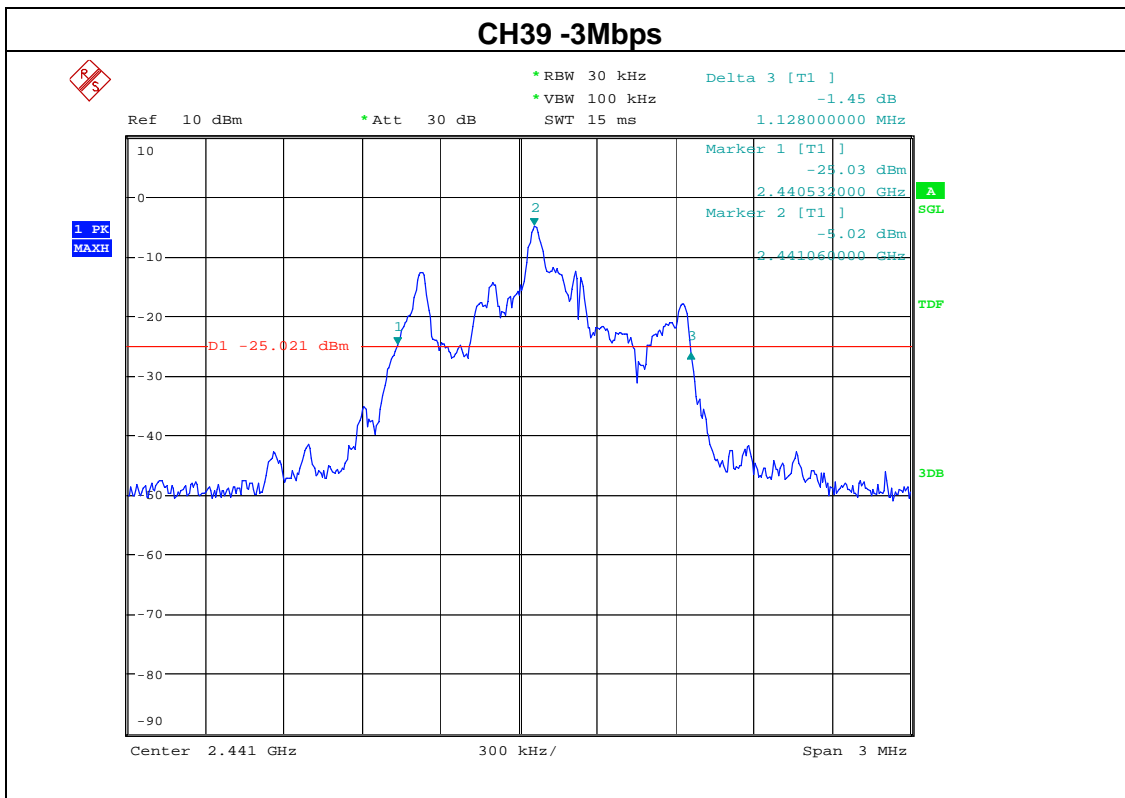

10. PEAK OUTPUT POWER TEST**10.1 APPLIED PROCEDURES / LIMIT**

FCC Part15 (15.247) , Subpart C				
Section	Test Item	Limit	Frequency Range (MHz)	Result
15.247 (b)(i)	Peak Output Power	0.125 w or 20.96dBm	2400-2483.5	PASS

10.2 TEST PROCEDURE

- a. Remove the antenna from the EUT and then connect a low loss RF cable from the antenna port to the power meter though a power sensor and antenna output port as show in the block diagram below,
- b. Record the result

10.3 DEVIATION FROM STANDARD

No deviation.

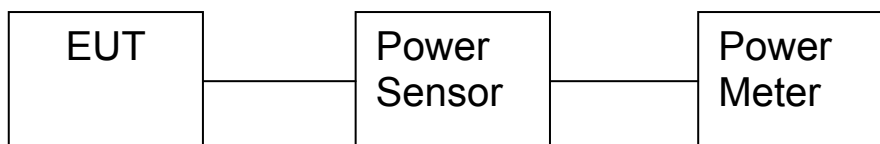
10.4 TEST SETUP**10.5 EUT OPERATION CONDITIONS**

The EUT tested system was configured as the statements of 2.4 Unless otherwise a special operating condition is specified in the follows during the testing.

10.6 TEST RESULTS

EUT	MULTIMEDIA SPEAKER	Model Name	SPME51
Temperature	25 °C	Relative Humidity	60%
Pressure	1012 hPa	Test Mode	CH00/ CH39 /CH78 (1M/2M/3Mbps Mode)
Test Date	August 15, 2015		

1Mbps				
Test Channel	Frequency (MHz)	Peak Output Power (dBm)	LIMIT(dBm)	Result
CH00	2402	0.21	20.96	Pass
CH39	2441	0.18	20.96	Pass
CH78	2480	0.20	20.96	Pass
2Mbps				
CH00	2402	0.51	20.96	Pass
CH39	2441	0.47	20.96	Pass
CH78	2480	0.48	20.96	Pass
3Mbps				
CH00	2402	0.57	20.96	Pass
CH39	2441	0.53	20.96	Pass
CH78	2480	0.51	20.96	Pass

11. ANTENNA APPLICATION

11.1 Antenna requirement

The EUT'S antenna is met the requirement of FCC part 15C section 15.203 and 15.247

11.2 Result

The EUT's antenna integrated on PCB, The antenna's gain is 1.0dBi and meets the requirement.

12. EUT TEST PHOTO

CONDUCTED EMISSION TEST



RADIATED EMISSION TEST

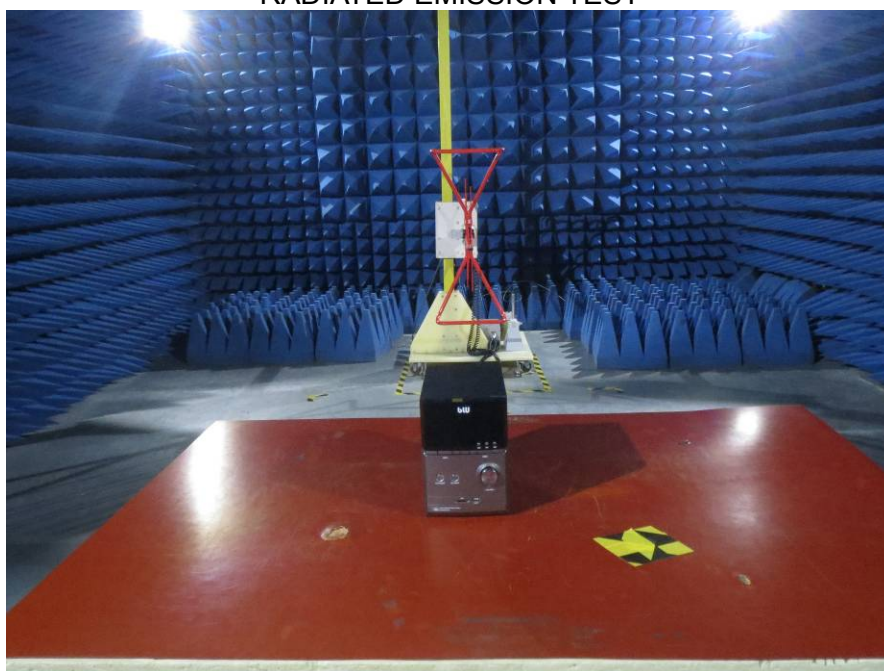

RADIATED EMISSION TEST



RF TEST



13. PHOTOGRAPHS OF EUT

Appearance photograph of EUT



Appearance photograph of EUT

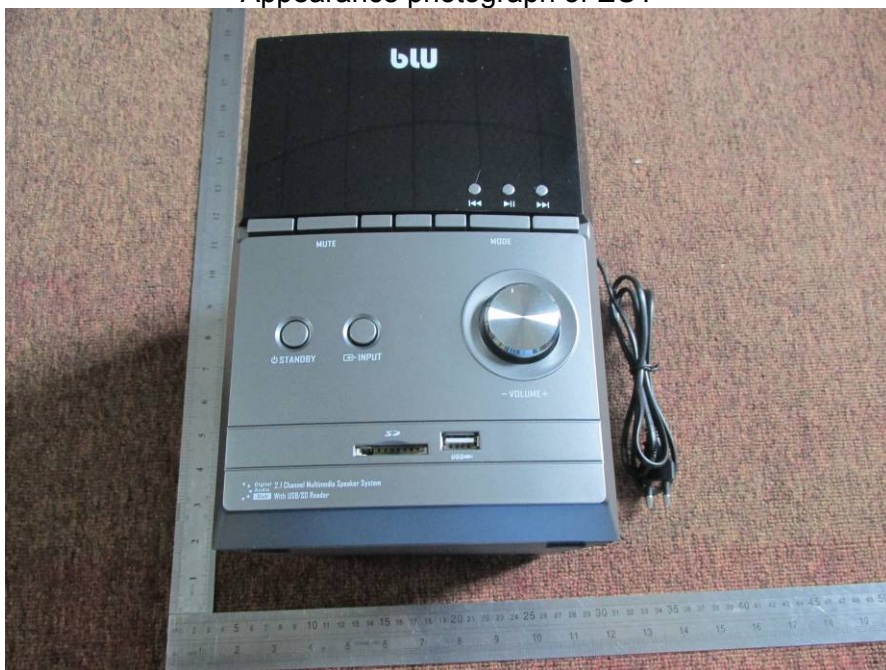

Appearance photograph of EUT



Appearance photograph of EUT



Appearance photograph of EUT



Appearance photograph of EUT

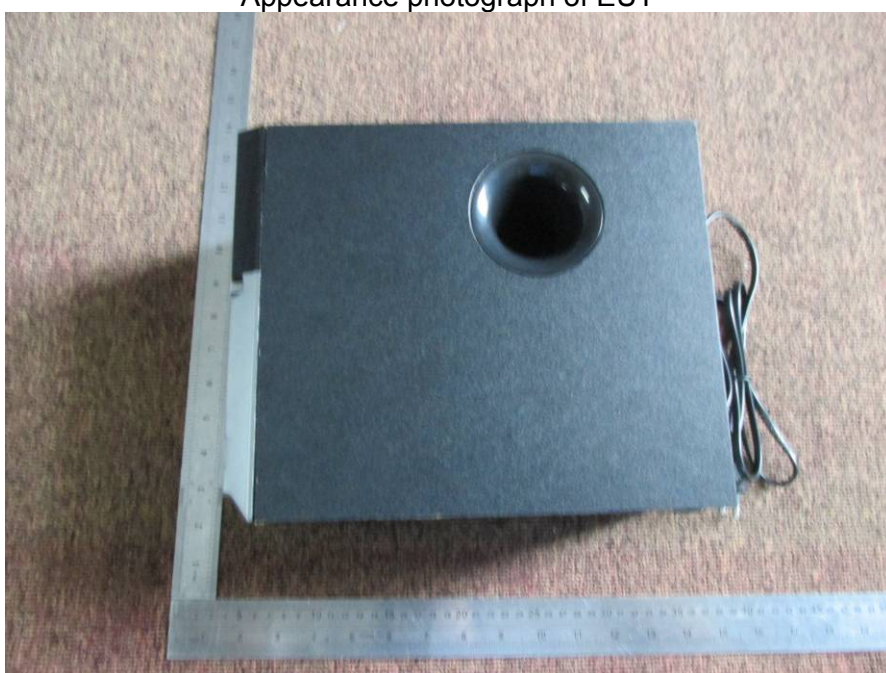

Appearance photograph of EUT



Internal photograph of EUT



Internal photograph of EUT

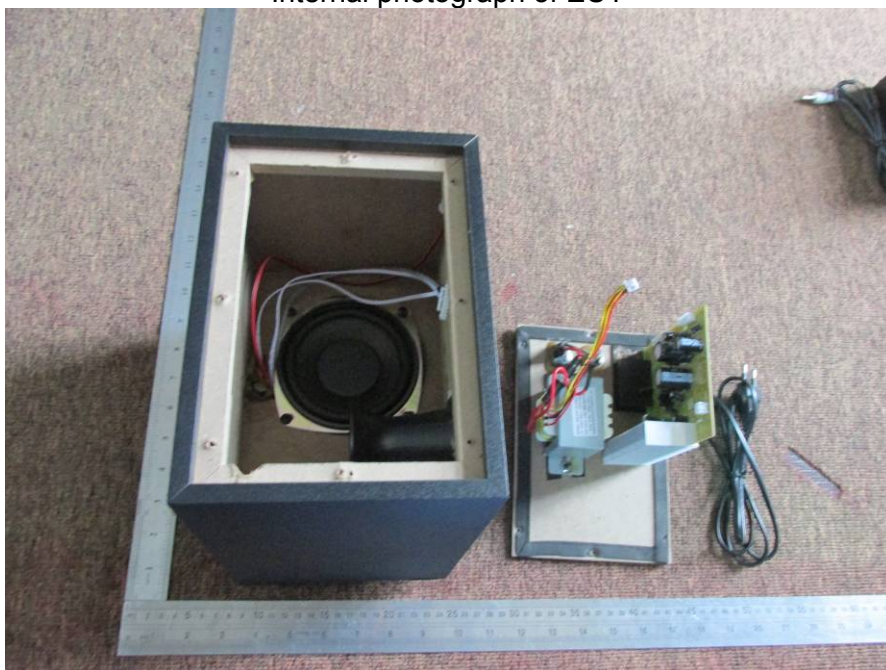

PCB photograph of EUT

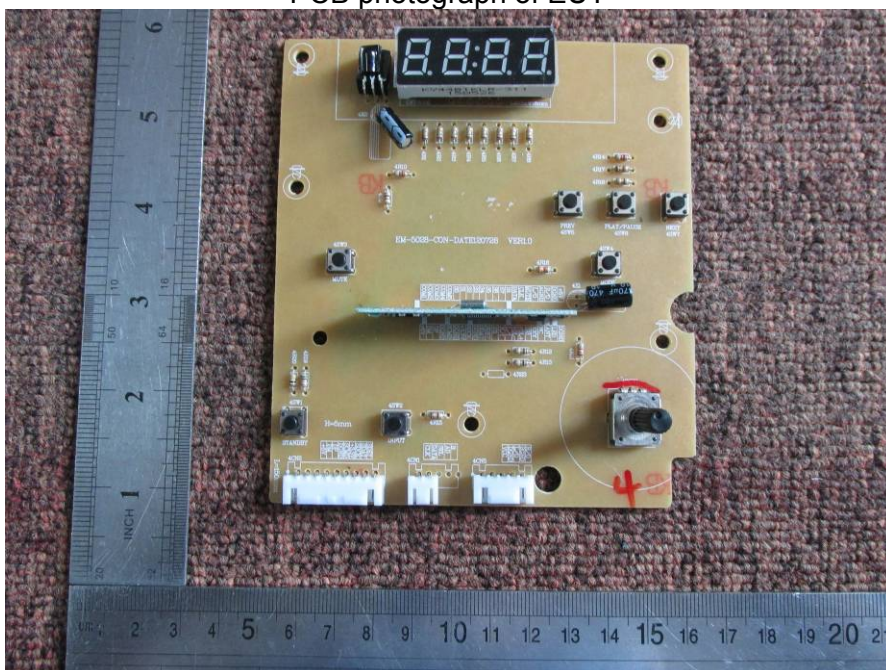

PCB photograph of EUT

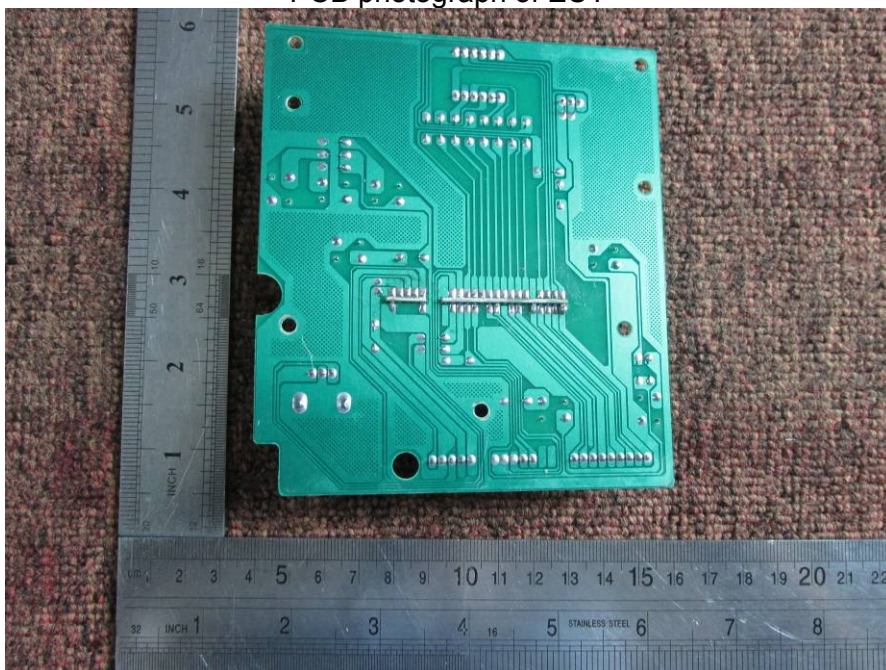

PCB photograph of EUT

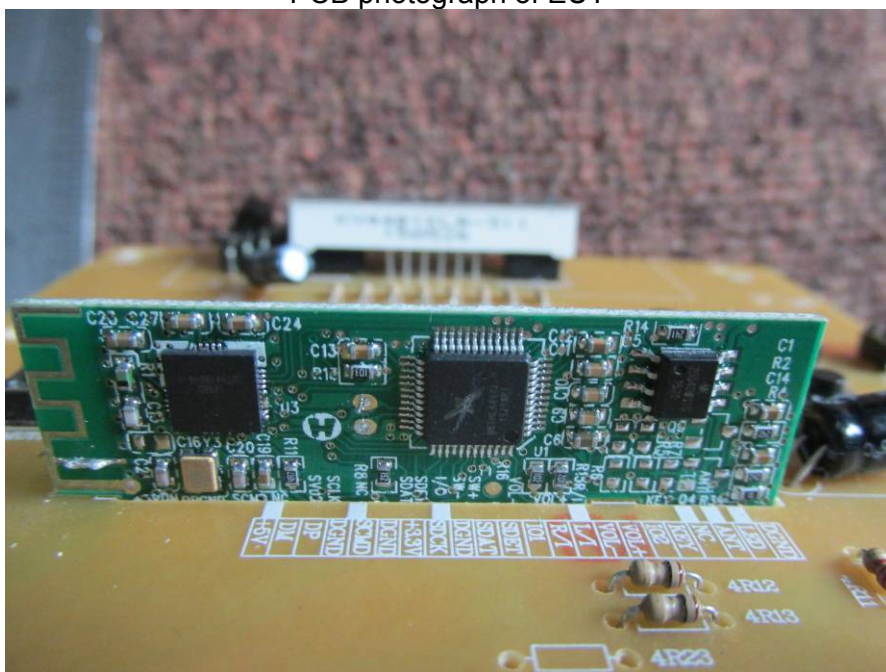

PCB photograph of EUT

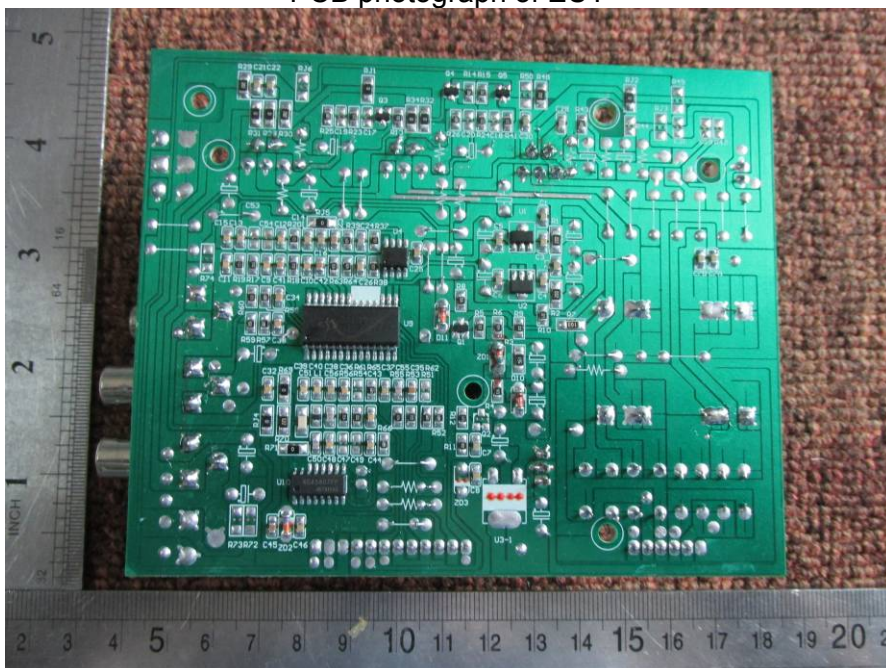

PCB photograph of EUT

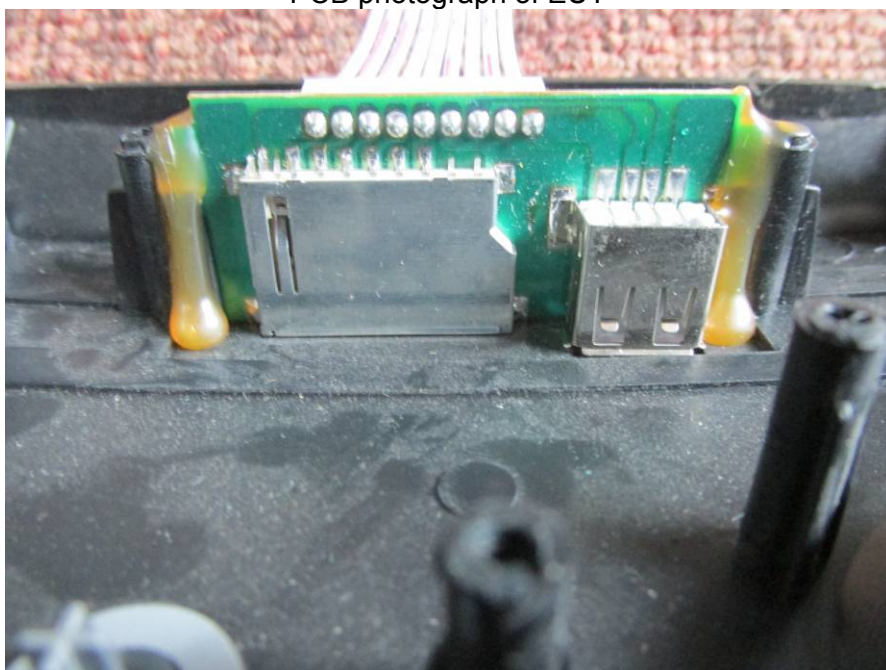

PCB photograph of EUT

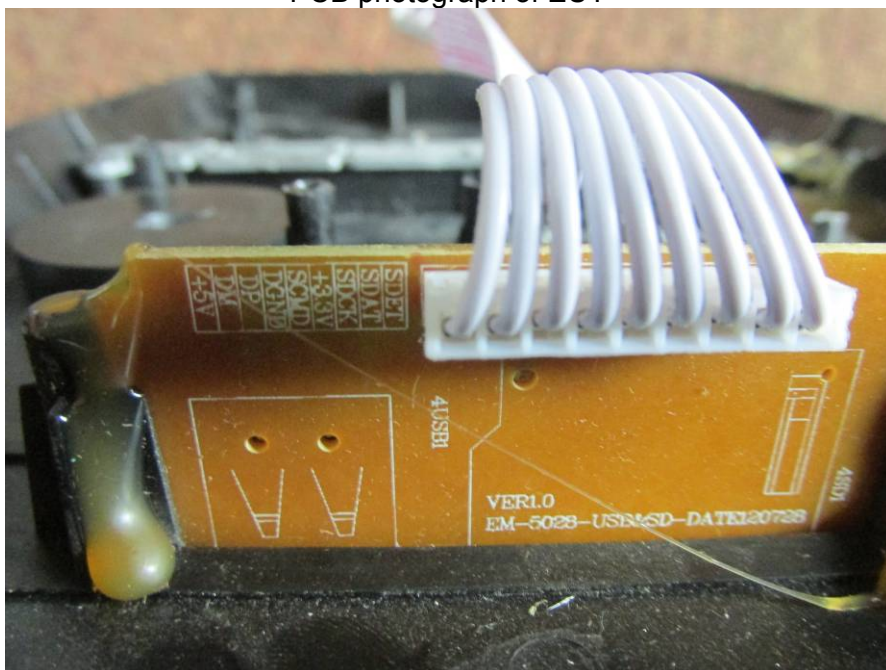

—END OF REPORT—