

TEST REPORT

CERTIFICATE OF CONFORMITY

Standard: 47 CFR FCC Part 15, Subpart C (Section 15.247)
Report No.: RFBGWF-WTW-P23030941
FCC ID: 2AD37JVU300TX
Product: 2K AI-Powered Webcam with Wireless Microphone and Auto-Focus
Brand: j5create
Model No.: JVU300TX
Received Date: 2023/3/30
Test Date: 2023/11/30 ~ 2023/12/12
Issued Date: 2024/1/9

Applicant: KAIJET TECHNOLOGY INTERNATIONAL CORPORATION
Address: 8F., No109, Zhongcheng Rd., Tucheng Dist., New Taipei City, 236 Taiwan
Issued By: Bureau Veritas Consumer Products Services (H.K.) Ltd., Taoyuan Branch
Lin Kou Laboratories
Lab Address: No. 47-2, 14th Ling, Chia Pau Vil., Lin Kou Dist., New Taipei City, Taiwan
Test Location: No. 47-2, 14th Ling, Chia Pau Vil., Lin Kou Dist., New Taipei City, Taiwan
FCC Registration / 198487 / TW2021
Designation Number:

Approved by: _____

Jeremy Lin

, Date: _____

2024/1/9

Jeremy Lin / Project Engineer

This test report consists of 66 pages in total. It may be duplicated completely for legal use with the approval of the applicant. It should not be reproduced except in full, without the written approval of our laboratory. The test results in the report only apply to the tested sample. The test results in this report are traceable to the national or international standards.



Prepared by : Jessica Cheng / Senior Specialist

This report is governed by, and incorporates by reference, the Conditions of Testing as posted at the date of issuance of this report at <http://www.bureauveritas.com/home/about-us/our-business/cps/about-us/terms-conditions/> and is intended for your exclusive use. Any copying or replication of this report to or for any other person or entity, or use of our name or trademark, is permitted only with our prior written permission. This report sets forth our findings solely with respect to the test samples identified herein. The results set forth in this report are not indicative or representative of the quality or characteristics of the lot from which a test sample was taken or any similar or identical product unless specifically and expressly noted. Our report includes all of the tests requested by you and the results thereof based upon the information that you provided to us. Measurement uncertainty is only provided upon request for accredited tests. Statements of conformity are based on simple acceptance criteria without taking measurement uncertainty into account, unless otherwise requested in writing. You have 60 days from date of issuance of this report to notify us of any material error or omission caused by our negligence or if you require measurement uncertainty; provided, however, that such notice shall be in writing and shall specifically address the issue you wish to raise. A failure to raise such issue within the prescribed time shall constitute your unqualified acceptance of the completeness of this report, the tests conducted and the correctness of the report contents.

Table of Contents

| | |
|---------------------------------------------------------------------|-----------|
| Release Control Record | 4 |
| 1 Certificate | 5 |
| 2 Summary of Test Results | 6 |
| 2.1 Measurement Uncertainty | 6 |
| 2.2 Supplementary Information | 6 |
| 3 General Information | 7 |
| 3.1 General Description | 7 |
| 3.2 Antenna Description of EUT | 8 |
| 3.3 Channel List | 9 |
| 3.4 Test Mode Applicability and Tested Channel Detail | 10 |
| 3.5 Duty Cycle of Test Signal | 11 |
| 3.6 Test Program Used and Operation Descriptions | 13 |
| 3.7 Connection Diagram of EUT and Peripheral Devices | 13 |
| 3.8 Configuration of Peripheral Devices and Cable Connections | 14 |
| 4 Test Instruments | 15 |
| 4.1 RF Output Power | 15 |
| 4.2 Power Spectral Density | 15 |
| 4.3 6 dB Bandwidth | 15 |
| 4.4 Conducted Out of Band Emissions | 15 |
| 4.5 AC Power Conducted Emissions | 16 |
| 4.6 Unwanted Emissions below 1 GHz | 17 |
| 4.7 Unwanted Emissions above 1 GHz | 18 |
| 5 Limits of Test Items | 19 |
| 5.1 RF Output Power | 19 |
| 5.2 Power Spectral Density | 19 |
| 5.3 6 dB Bandwidth | 19 |
| 5.4 Conducted Out of Band Emissions | 19 |
| 5.5 AC Power Conducted Emissions | 19 |
| 5.6 Unwanted Emissions below 1 GHz | 19 |
| 5.7 Unwanted Emissions above 1 GHz | 20 |
| 6 Test Arrangements | 21 |
| 6.1 RF Output Power | 21 |
| 6.1.1 Test Setup | 21 |
| 6.1.2 Test Procedure | 21 |
| 6.2 Power Spectral Density | 21 |
| 6.2.1 Test Setup | 21 |
| 6.2.2 Test Procedure | 21 |
| 6.3 6 dB Bandwidth | 22 |
| 6.3.1 Test Setup | 22 |
| 6.3.2 Test Procedure | 22 |
| 6.4 Conducted Out of Band Emissions | 22 |
| 6.4.1 Test Setup | 22 |
| 6.4.2 Test Procedure | 22 |
| 6.5 AC Power Conducted Emissions | 23 |
| 6.5.1 Test Setup | 23 |
| 6.5.2 Test Procedure | 23 |
| 6.6 Unwanted Emissions below 1 GHz | 24 |
| 6.6.1 Test Setup | 24 |
| 6.6.2 Test Procedure | 25 |
| 6.7 Unwanted Emissions above 1 GHz | 26 |
| 6.7.1 Test Setup | 26 |
| 6.7.2 Test Procedure | 26 |
| 7 Test Results of Test Item | 27 |



| | | |
|----------|------------------------------------------------------|-----------|
| 7.1 | RF Output Power | 27 |
| 7.2 | Power Spectral Density | 29 |
| 7.3 | 6 dB Bandwidth | 31 |
| 7.4 | Conducted Out of Band Emissions | 33 |
| 7.5 | AC Power Conducted Emissions | 37 |
| 7.6 | Unwanted Emissions below 1 GHz | 41 |
| 7.7 | Unwanted Emissions above 1 GHz | 45 |
| 8 | Pictures of Test Arrangements | 65 |
| 9 | Information of the Testing Laboratories | 66 |



Release Control Record

| Issue No. | Description | Date Issued |
|----------------------|-------------------|-------------|
| RFBGWF-WTW-P23030941 | Original release. | 2024/1/9 |

1 Certificate

Product: 2K AI-Powered Webcam with Wireless Microphone and Auto-Focus

Brand: j5create

Test Model: JVU300TX

Sample Status: Engineering sample

Applicant: KAIJET TECHNOLOGY INTERNATIONAL CORPORATION

Test Date: 2023/11/30 ~ 2023/12/12

Standard: 47 CFR FCC Part 15, Subpart C (Section 15.247)

Measurement ANSI C63.10-2013

procedure: KDB 558074 D01 15.247 Meas Guidance v05r02

The above equipment has been tested by **Bureau Veritas Consumer Products Services (H.K.) Ltd., Taoyuan Branch**, and found compliance with the requirement of the above standards. The test record, data evaluation & Equipment Under Test (EUT) configurations represented herein are true and accurate accounts of the measurements of the sample's RF characteristics under the conditions specified in this report.

2 Summary of Test Results

| 47 CFR FCC Part 15, Subpart C (Section 15.247) | | | |
|------------------------------------------------|---------------------------------|--------|---------------------------------------------------------|
| Standard / Clause | Test Item | Result | Remark |
| 15.247(b) | RF Output Power | Pass | Meet the requirement of limit. |
| 15.247(e) | Power Spectral Density | Pass | Meet the requirement of limit. |
| 15.247(a)(2) | 6 dB Bandwidth | Pass | Meet the requirement of limit. |
| 15.247(d) | Conducted Out of Band Emissions | Pass | Meet the requirement of limit. |
| 15.207 | AC Power Conducted Emissions | Pass | Minimum passing margin is -10.92 dB at 0.54397 MHz |
| 15.205 / 15.209 / 15.247(d) | Unwanted Emissions below 1 GHz | Pass | Minimum passing margin is -10.4 dB at 32.89 MHz |
| 15.205 / 15.209 / 15.247(d) | Unwanted Emissions above 1 GHz | Pass | Minimum passing margin is -2.7 dB at 4960.00 MHz |
| 15.203 | Antenna Requirement | Pass | Antenna connector is ipex(MHF) not a standard connector |

Note: Determining compliance based on the results of the compliance measurement, not taking into account measurement instrumentation uncertainty.

2.1 Measurement Uncertainty

Where relevant, the following measurement uncertainty levels have been estimated for tests performed on the EUT as specified in CISPR 16-4-2:

| Measurement | Specification | Expanded Uncertainty (k=2) (±) |
|---------------------------------|-----------------|-----------------------------------|
| RF Output Power | - | 1.1 dB |
| Power Spectral Density | - | 1.2 dB |
| 6 dB Bandwidth | - | 960 Hz |
| Conducted Out of Band Emissions | 9 kHz ~ 40 GHz | 2.63 dB |
| AC Power Conducted Emissions | 9 kHz ~ 30 MHz | 2.88 dB |
| Unwanted Emissions below 1 GHz | 9 kHz ~ 30 MHz | 2.38 dB |
| | 30 MHz ~ 1 GHz | 5.7 dB |
| Unwanted Emissions above 1 GHz | 1 GHz ~ 6 GHz | 4.83 dB |
| | 6 GHz ~ 18 GHz | 5.37 dB |
| | 18 GHz ~ 40 GHz | 5.24 dB |

The other instruments specified are routine verified to remain within the calibrated levels, no measurement uncertainty is required to be calculated.

2.2 Supplementary Information

There is not any deviation from the test standards for the test method, and no modifications required for compliance.

3 General Information

3.1 General Description

| | |
|-----------------------|--------------------------------------------------------------|
| Product | 2K AI-Powered Webcam with Wireless Microphone and Auto-Focus |
| Brand | j5create |
| Test Model | JVU300TX |
| Status of EUT | Engineering sample |
| Power Supply Rating | 3.7Vdc from Battery or 5Vdc from DC input |
| Modulation Type | GFSK |
| Modulation Technology | DTS |
| Transfer Rate | 125k, 500k, 1M, 2M |
| Operating Frequency | 2.402 GHz ~ 2.48 GHz |
| Number of Channel | 40 |
| Output Power | 4.92 mW (6.92 dBm) |

Note:

1. The EUT must be supplied with a battery as the following table:

| Item | Brand | Model | Specification |
|---------|-----------------------|----------|-------------------------------------|
| Battery | Taiwan Senko Co.,Ltd. | GN451225 | Power Rating : 3.7V, 100mAh, 0.37Wh |

2. The EUT could be supplied with Charger IC as below table:

| Item | Brand | Model | Specification |
|------------|-------|---------|---------------------|
| Charger IC | ETA | ETA4054 | Power Rating : 4.2V |

3. The above EUT information is declared by manufacturer and for more detailed features description, please refer to the manufacturer's specifications or User's Manual.

3.2 Antenna Description of EUT

1. The antenna information is listed as below.

| Gain (dBi) | Antenna Type | Connector Type |
|------------|--------------|----------------|
| 2.19 | PCB | ipex(MHF) |

* Detail antenna specification please refer to antenna datasheet and/or antenna measurement report.

3.3 Channel List

40 channels are provided for BT-LE:

| Channel | Frequency (MHz) | Channel | Frequency (MHz) | Channel | Frequency (MHz) | Channel | Frequency (MHz) |
|---------|-----------------|---------|-----------------|---------|-----------------|---------|-----------------|
| 0 | 2402 | 10 | 2422 | 20 | 2442 | 30 | 2462 |
| 1 | 2404 | 11 | 2424 | 21 | 2444 | 31 | 2464 |
| 2 | 2406 | 12 | 2426 | 22 | 2446 | 32 | 2466 |
| 3 | 2408 | 13 | 2428 | 23 | 2448 | 33 | 2468 |
| 4 | 2410 | 14 | 2430 | 24 | 2450 | 34 | 2470 |
| 5 | 2412 | 15 | 2432 | 25 | 2452 | 35 | 2472 |
| 6 | 2414 | 16 | 2434 | 26 | 2454 | 36 | 2474 |
| 7 | 2416 | 17 | 2436 | 27 | 2456 | 37 | 2476 |
| 8 | 2418 | 18 | 2438 | 28 | 2458 | 38 | 2478 |
| 9 | 2420 | 19 | 2440 | 29 | 2460 | 39 | 2480 |

3.4 Test Mode Applicability and Tested Channel Detail

| | |
|-------------|----------------------------------------------------------------------------------------------------------------------------------------------------------------------------------------------------------------------------------------------------------------------------------------------------------------------------------------------------------------------------------------|
| Pre-Scan: | 1. EUT can be used in the following ways: XYZ 3-axis. Pre-scan in these ways and find the worst case as a representative test condition. 2. For Unwanted Emission below 1 GHz has Charging with 2K AI-Powered Webcam and Laptop/ Charging with 2K AI-Powered Webcam and Adapter mode of power supply. Pre-scan and find the worst charging case as a representative test condition. |
| Worst Case: | 1. X/ Y/ Z Worst Condition: Z Axis for Unwanted Emission above 1GHz and Unwanted Emission below 1GHz. 2. For Unwanted Emission below 1 GHz Charging with 2K AI-Powered Webcam and Laptop mode is the worst charging case of power supply. |

Following channel(s) was (were) selected for the final test as listed below:

| Test Item | EUT Configure Mode | Mode | Tested Channel | Modulation | Data Rate Parameter |
|--------------------------------------------------|--------------------|------------------------------------------------|----------------|------------|---------------------|
| RF Output Power / Power Spectral Density | A | BT-LE 1M | 0, 19, 39 | GFSK | 1Mb/s |
| | | BT-LE 2M | 0, 19, 39 | GFSK | 2Mb/s |
| | | BT-LE 125k | 0, 19, 39 | GFSK | 125kb/s |
| | | BT-LE 500k | 0, 19, 39 | GFSK | 500kb/s |
| 6 dB Bandwidth / Conducted Out of Band Emissions | A | BT-LE 1M | 0, 19, 39 | GFSK | 1Mb/s |
| | | BT-LE 2M | 0, 19, 39 | GFSK | 2Mb/s |
| | | BT-LE 125k | 0, 19, 39 | GFSK | 125kb/s |
| | | BT-LE 500k | 0, 19, 39 | GFSK | 500kb/s |
| AC Power Conducted Emissions | B | - | - | - | - |
| | C | - | - | - | - |
| Unwanted Emissions below 1 GHz | A | BT-LE 2M | 0 | GFSK | 2Mb/s |
| | B | - | - | - | - |
| Unwanted Emissions above 1 GHz | A | BT-LE 1M | 0, 19, 39 | GFSK | 1Mb/s |
| | | BT-LE 2M | 0, 19, 39 | GFSK | 2Mb/s |
| | | BT-LE 125k | 0, 19, 39 | GFSK | 125kb/s |
| | | BT-LE 500k | 0, 19, 39 | GFSK | 500kb/s |
| EUT Configure Mode: | A | EUT only | | | |
| | B | Charging with 2K AI-Powered Webcam and Laptop | | | |
| | C | Charging with 2K AI-Powered Webcam and Adapter | | | |

3.5 Duty Cycle of Test Signal

BT-LE 1M: Duty cycle = 0.419 ms / 2.777 ms x 100% = 15.1%, duty factor = 10 * log (1/Duty cycle) = 8.21 dB

BT-LE 2M: Duty cycle = 0.209 ms / 2.569 ms x 100% = 8.1%, duty factor = 10 * log (1/Duty cycle) = 10.90 dB

BT-LE 125k: Duty cycle = 3.091 ms / 5.447 ms x 100% = 56.8%, duty factor = 10 * log (1/Duty cycle) = 2.46 dB

BT-LE 500k: Duty cycle = 1.075 ms / 3.433 ms x 100% = 31.3%, duty factor = 10 * log (1/Duty cycle) = 5.04 dB

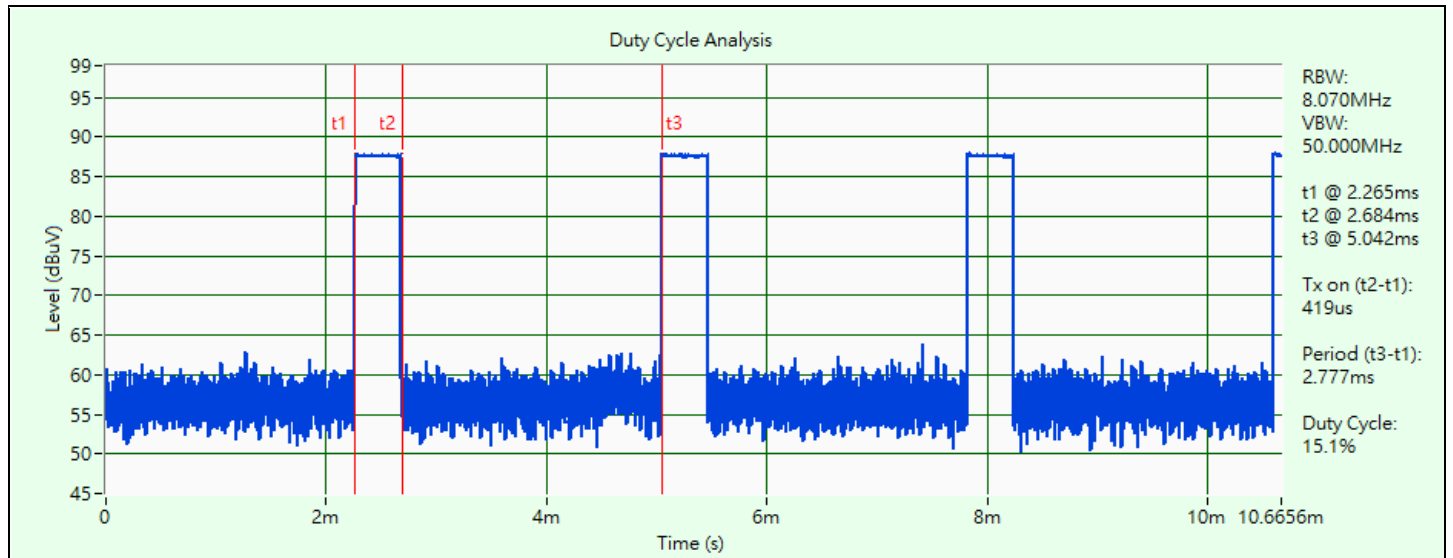

BT-LE 1M

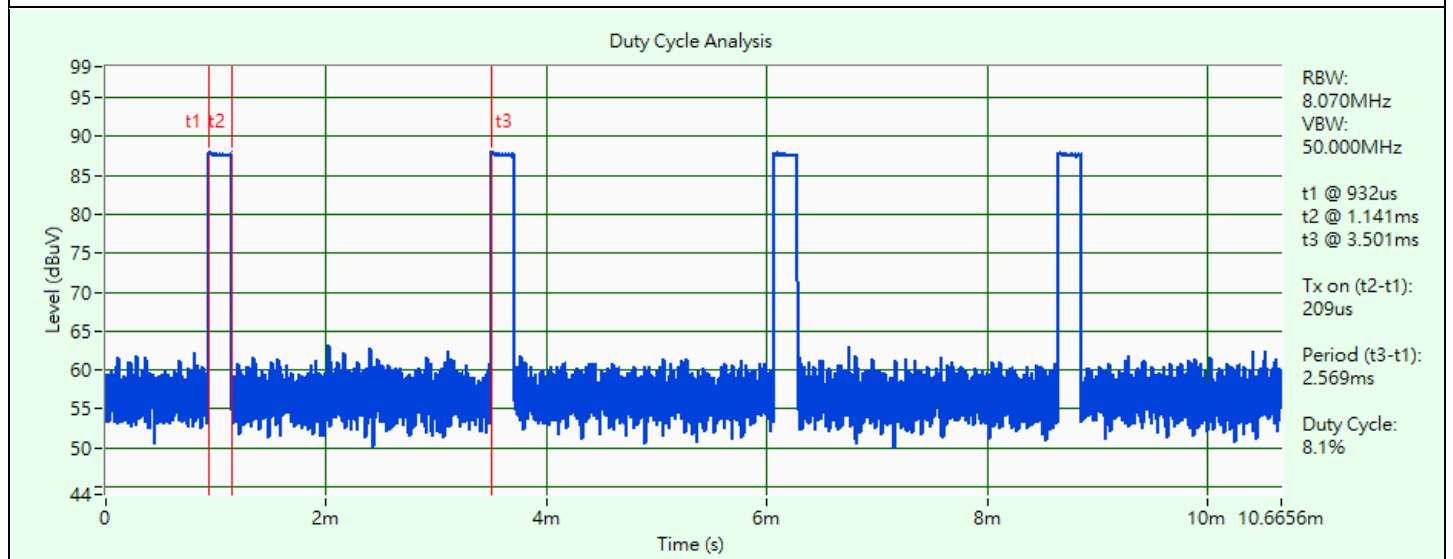

BT-LE 2M

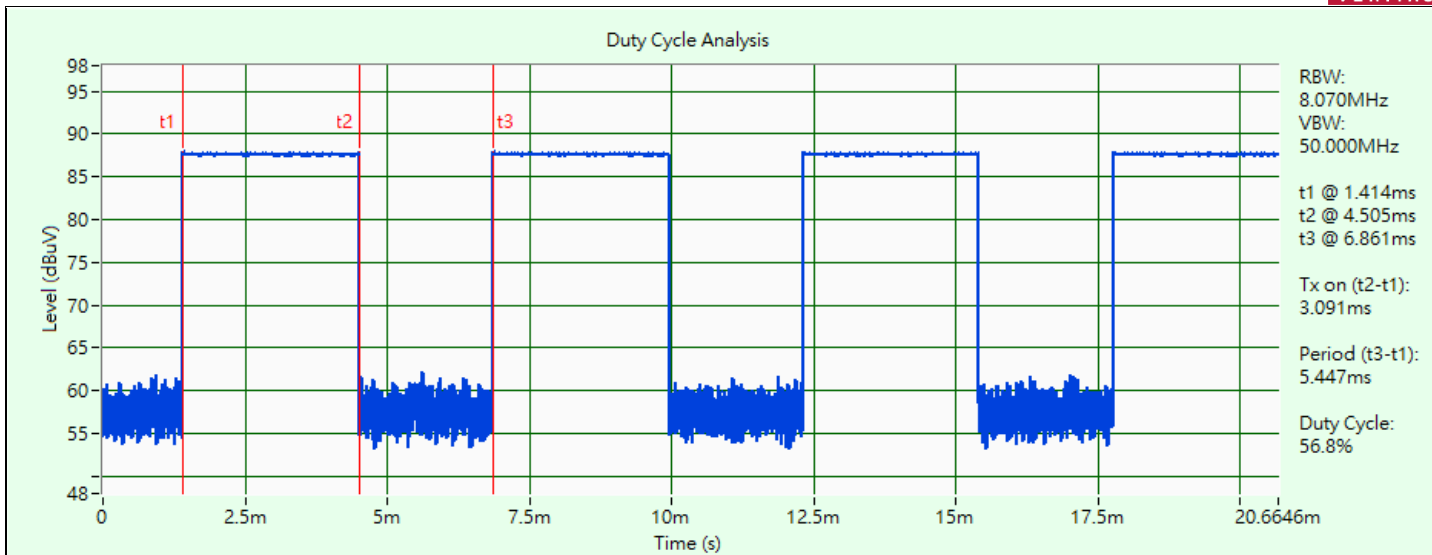

BT-LE 125k

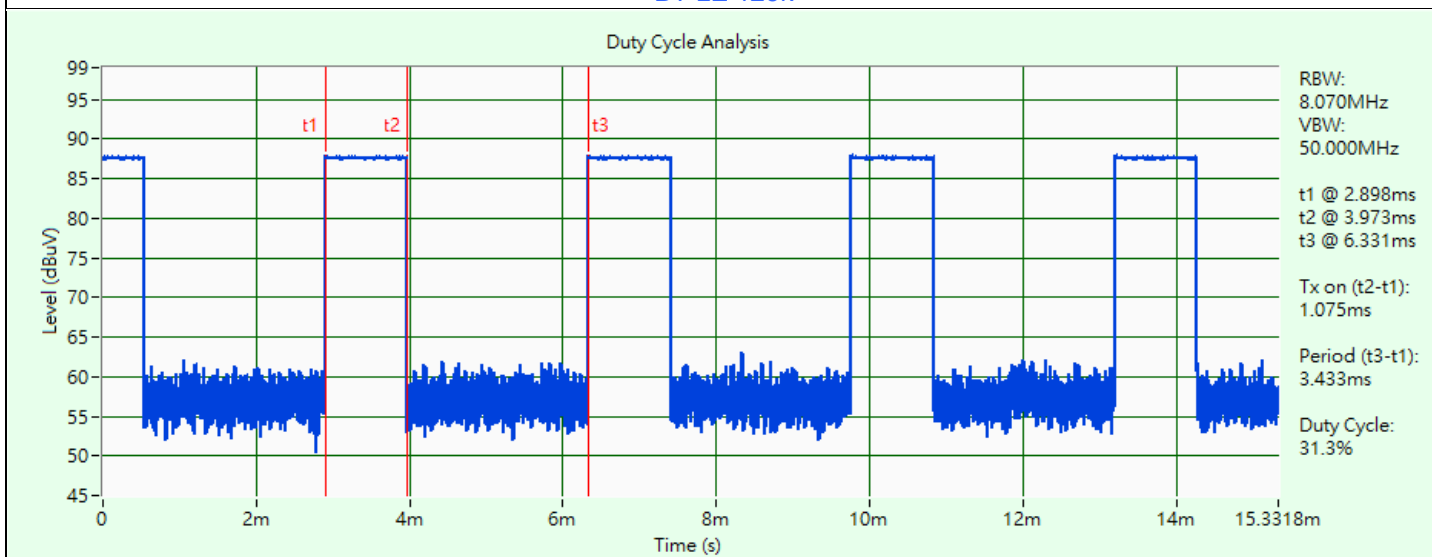

BT-LE 500k

3.6 Test Program Used and Operation Descriptions

Controlling software (Non_Signaling_Test_Tool V2.1) has been activated to set the EUT under transmission condition continuously at specific channel frequency.

3.7 Connection Diagram of EUT and Peripheral Devices

Mode A



Mode B

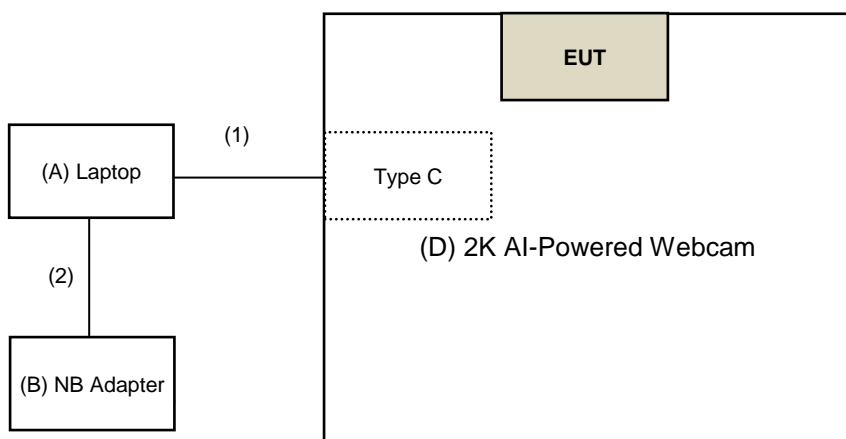

Mode C

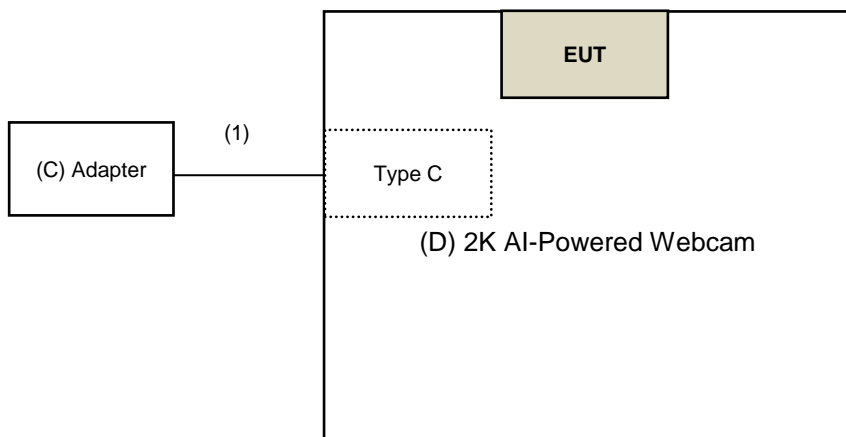

3.8 Configuration of Peripheral Devices and Cable Connections

| ID | Product | Brand | Model No. | Serial No. | FCC ID | Remarks |
|----|----------------------|----------|--------------|------------|---------------|-----------------------|
| A | Laptop | Lenovo | 80WG | YD01YRC9 | N/A | Provided by Lab |
| B | NB Adapter | Lenovo | ADLX65CLGC2A | N/A | N/A | Provided by Lab |
| C | Adapter | Belkin | WCB007dq | N/A | N/A | Provided by Lab |
| D | 2K AI-Powered Webcam | j5create | JVU300RX | N/A | 2AD37JVU300RX | Supplied by applicant |

| ID | Cable Descriptions | Qty. | Length (m) | Shielding (Yes/No) | Cores (Qty.) | Remarks |
|----|--------------------|------|------------|--------------------|--------------|-----------------------|
| 1 | USB Cable | 1 | 1.8 | Y | 0 | Supplied by applicant |
| 2 | DC Cable | 1 | 1.8 | N | 0 | Provided by Lab |

4 Test Instruments

The calibration interval of the all test instruments are 12 months and the calibrations are traceable to NML/ROC and NIST/USA.

4.1 RF Output Power

| Description Manufacturer | Model No. | Serial No. | Calibrated Date | Calibrated Until |
|---------------------------------------|-----------|-------------|--------------------|---------------------|
| Power Meter Anritsu | ML2495A | 0842014 | 2023/5/5 | 2024/5/4 |
| Pulse Power Sensor Anritsu | MA2411B | 0738404 | 2023/5/5 | 2024/5/4 |
| USB Wideband Power Sensor Keysight | U2021XA | U2021XA_001 | 2023/6/6 | 2024/6/5 |

Notes:

1. The test was performed in LK - Oven
2. Tested Date: 2023/12/12

4.2 Power Spectral Density

| Description Manufacturer | Model No. | Serial No. | Calibrated Date | Calibrated Until |
|---------------------------------|----------------------------------|------------|--------------------|---------------------|
| PXA Signal Analyzer Keysight | N9030A | MY54490260 | 2023/7/13 | 2024/7/12 |
| Signal Analyzer R&S | FSV40 | 101042 | 2023/9/5 | 2024/9/4 |
| | | 101544 | 2023/5/9 | 2024/5/8 |
| Software | ADT_RF Test Software V6.6.5.4 | N/A | N/A | N/A |

Notes:

1. The test was performed in LK - Oven
2. Tested Date: 2023/12/12

4.3 6 dB Bandwidth

Refer to section 4.2 to get information of the instruments.

4.4 Conducted Out of Band Emissions

Refer to section 4.2 to get information of the instruments.

4.5 AC Power Conducted Emissions

| Description Manufacturer | Model No. | Serial No. | Calibrated Date | Calibrated Until |
|--------------------------------------|---------------|--------------|--------------------|---------------------|
| 50 ohm terminal resistance LYNICS | 0900510 | E1-01-305 | 2023/2/13 | 2024/2/12 |
| | | E1-011285 | 2023/9/21 | 2024/9/20 |
| | | E1-011286 | 2023/9/21 | 2024/9/20 |
| EMI Test Receiver R&S | ESCS 30 | 100276 | 2023/4/20 | 2024/4/19 |
| | ESR3 | 102412 | 2022/12/21 | 2023/12/20 |
| Fixed Attenuator STI | STI02-2200-10 | NO.4 | 2023/9/1 | 2024/8/31 |
| High Voltage Probe Schwarzbeck | TK9420 | 00982 | 2022/12/14 | 2023/12/13 |
| LISN R&S | ENV216 | 101197 | 2023/7/12 | 2024/7/11 |
| LISN Schwarzbeck | NNLK 8121 | 8121-731 | 2023/6/9 | 2024/6/8 |
| | | 8121-808 | 2023/5/2 | 2024/5/1 |
| | NNLK 8129 | 8129229 | 2023/6/27 | 2024/6/26 |
| | NSLK 8128 | 8128-244 | 2023/11/10 | 2024/11/9 |
| RF Coaxial Cable PEWC | 5D-FB | Cable-CO5-01 | 2023/1/19 | 2024/1/18 |
| Software BVADT | Cond_V7.3.7.4 | N/A | N/A | N/A |

Notes:

1. The test was performed in Linkou Conduction 5.
2. Tested Date: 2023/11/30

4.6 Unwanted Emissions below 1 GHz

| Description Manufacturer | Model No. | Serial No. | Calibrated Date | Calibrated Until |
|----------------------------------------------|------------------|--------------|--------------------|---------------------|
| Bi_Log Antenna Schwarzbeck | VULB 9168 | 137 | 2023/10/13 | 2024/10/12 |
| Coupling / Decoupling Network Schwarzbeck | CDNE-M2 | 00097 | 2023/5/25 | 2024/5/24 |
| | CDNE-M3 | 00091 | 2023/5/25 | 2024/5/24 |
| Loop Antenna EMCI | LPA600 | 270 | 2023/9/4 | 2024/9/3 |
| MXE EMI Receiver Agilent | N9038A | MY51210129 | 2023/3/24 | 2024/3/23 |
| | | MY51210137 | 2023/6/5 | 2024/6/4 |
| Preamplifier EMCI | EMC001340 | 980269 | 2023/6/27 | 2024/6/26 |
| Preamplifier HP | 8447D | 2432A03504 | 2023/2/16 | 2024/2/15 |
| RF Coaxial Cable Pacific | 8D-FB | Cable-CH6-02 | 2023/6/27 | 2024/6/26 |
| Signal Analyzer R&S | FSV40 | 101544 | 2023/5/9 | 2024/5/8 |
| Software BVADT | Radiated_V8.7.08 | N/A | N/A | N/A |
| Tower ADT | AT100 | 0306 | N/A | N/A |
| Turn Table ADT | TT100 | 0306 | N/A | N/A |

Notes:

1. The test was performed in Linkou 966 Chamber 6 (CH 6).
2. Tested Date: 2023/11/30

4.7 Unwanted Emissions above 1 GHz

| Description Manufacturer | Model No. | Serial No. | Calibrated Date | Calibrated Until |
|---------------------------------------|---------------------|--------------|--------------------|---------------------|
| Band Pass Filter Micro-Tronics | BRM17690 | 005 | 2023/5/25 | 2024/5/24 |
| Boresight antenna tower fixture BV | BAF-02 | 6 | N/A | N/A |
| High Pass Filter Wainwright | WHK 3.1/18G-10SS | SN 8 | 2023/5/25 | 2024/5/24 |
| Horn Antenna EMCO | 3115 | 00028257 | 2023/11/12 | 2024/11/11 |
| Horn Antenna ETS-Lindgren | 3117-PA | 00215857 | 2023/11/12 | 2024/11/11 |
| Horn Antenna Schwarzbeck | BBHA 9170 | 212 | 2023/10/16 | 2024/10/15 |
| | | BBHA9170241 | 2023/10/16 | 2024/10/15 |
| MXE EMI Receiver Agilent | N9038A | MY51210129 | 2023/3/24 | 2024/3/23 |
| | | MY51210137 | 2023/6/5 | 2024/6/4 |
| Notch Filter Micro-Tronics | BRC50703-01 | 010 | 2023/5/25 | 2024/5/24 |
| Preamplifier EMCI | EMC0126545 | 980076 | 2023/2/16 | 2024/2/15 |
| | EMC184045B | 980175 | 2023/9/2 | 2024/9/1 |
| | | | 980235 | 2023/2/16 |
| Preamplifier HP | 8449B | 3008A01201 | 2023/2/16 | 2024/2/15 |
| RF Coaxial Cable EMCI | EMC102-KM-KM-1000 | 200310 | 2023/3/12 | 2024/3/11 |
| | EMC104 | 190801 | 2023/9/13 | 2024/9/12 |
| | | 190804 | 2023/9/13 | 2024/9/12 |
| RF Coaxial Cable HUBER+SUHNER | SF-104 | Cable-CH6-01 | 2023/9/13 | 2024/9/12 |
| Signal Analyzer R&S | FSV40 | 101042 | 2023/9/5 | 2024/9/4 |
| | | 101544 | 2023/5/9 | 2024/5/8 |
| Software BVADT | Radiated_V7.7.1.1.1 | N/A | N/A | N/A |
| Tower ADT | AT100 | 0306 | N/A | N/A |
| Turn Table ADT | TT100 | 0306 | N/A | N/A |

Notes:

1. The test was performed in Linkou 966 Chamber 6 (CH 6).
2. Tested Date: 2023/12/4

5 Limits of Test Items

5.1 RF Output Power

For systems using digital modulation in the 2400–2483.5 MHz bands: 1 Watt (30 dBm)

5.2 Power Spectral Density

The Maximum of Power Spectral Density Measurement is 8 dBm in any 3 kHz.

5.3 6 dB Bandwidth

The minimum of 6 dB Bandwidth Measurement is 0.5 MHz.

5.4 Conducted Out of Band Emissions

Below 20 dB of the highest emission level of operating band (in 100 kHz Resolution Bandwidth).

5.5 AC Power Conducted Emissions

| Frequency (MHz) | Conducted Limit (dBuV) | |
|-----------------|------------------------|---------|
| | Quasi-peak | Average |
| 0.15 - 0.5 | 66 - 56 | 56 - 46 |
| 0.50 - 5.0 | 56 | 46 |
| 5.0 - 30.0 | 60 | 50 |

Notes:

1. The lower limit shall apply at the transition frequencies.
2. The limit decreases in line with the logarithm of the frequency in the range of 0.15 to 0.50 MHz.

5.6 Unwanted Emissions below 1 GHz

Radiated emissions up to 1 GHz which fall in the restricted bands must comply with the radiated emission limits specified as below table. Other emissions shall be at least 20 dB below the highest level of the desired power:

| Frequencies (MHz) | Field Strength (microvolts/meter) | Measurement Distance (meters) |
|-------------------|-----------------------------------|-------------------------------|
| 0.009 ~ 0.490 | 2400/F(kHz) | 300 |
| 0.490 ~ 1.705 | 24000/F(kHz) | 30 |
| 1.705 ~ 30.0 | 30 | 30 |
| 30 ~ 88 | 100 | 3 |
| 88 ~ 216 | 150 | 3 |
| 216 ~ 960 | 200 | 3 |
| Above 960 | 500 | 3 |

Notes:

1. The lower limit shall apply at the transition frequencies.
2. Emission level (dBuV/m) = 20 log Emission level (uV/m).

5.7 Unwanted Emissions above 1 GHz

Radiated emissions above 1 GHz which fall in the restricted bands must comply with the radiated emission limits specified as below table. Other emissions shall be at least 20 dB below the highest level of the desired power:

| Frequencies (MHz) | Field Strength (microvolts/meter) | Measurement Distance (meters) |
|-------------------|-----------------------------------|-------------------------------|
| Above 960 | 500 | 3 |

Notes:

1. The lower limit shall apply at the transition frequencies.
2. Emission level (dBuV/m) = 20 log Emission level (uV/m).
3. For frequencies above 1000 MHz, the field strength limits are based on average detector, however, the peak field strength of any emission shall not exceed the maximum permitted average limits, specified above by more than 20 dB under any condition of modulation.

6 Test Arrangements

6.1 RF Output Power

6.1.1 Test Setup

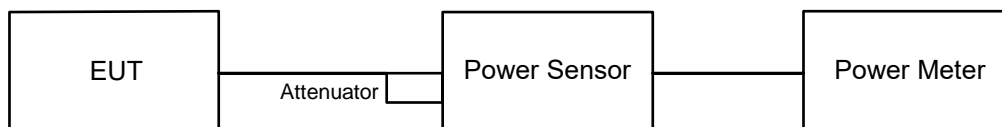

6.1.2 Test Procedure

Peak Power:

A peak power sensor was used on the output port of the EUT. A power meter was used to read the response of the peak power sensor. Record the power level.

Average Power:

Average power sensor was used to perform output power measurement, trigger and gating function of wide band power meter is enabled to measure max output power of TX on burst. Duty factor is not added to measured value.

6.2 Power Spectral Density

6.2.1 Test Setup

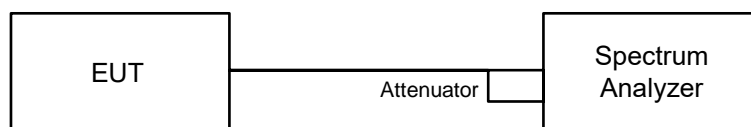

6.2.2 Test Procedure

- a. Set analyzer center frequency to DTS channel center frequency.
- b. Set the span to 1.5 times the DTS bandwidth.
- c. Set the RBW to: 3 kHz.
- d. Set the VBW $\geq 3 \times$ RBW.
- e. Detector = peak.
- f. Sweep time = auto couple.
- g. Trace mode = max hold.
- h. Allow trace to fully stabilize.
- i. Use the peak marker function to determine the maximum amplitude level within the RBW.

6.3 6 dB Bandwidth

6.3.1 Test Setup

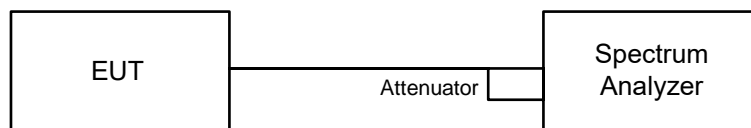

6.3.2 Test Procedure

- Set resolution bandwidth (RBW) = 100 kHz.
- Set the video bandwidth (VBW) $\geq 3 \times$ RBW, Detector = Peak.
- Trace mode = max hold.
- Sweep = auto couple.
- Measure the maximum width of the emission that is constrained by the frequencies associated with the two amplitude points (upper and lower) that are attenuated by 6 dB relative to the maximum level measured in the fundamental emission.

6.4 Conducted Out of Band Emissions

6.4.1 Test Setup

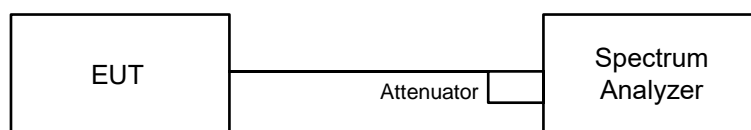

6.4.2 Test Procedure

MEASUREMENT PROCEDURE REF

- Set the RBW = 100 kHz.
- Set the VBW ≥ 300 kHz.
- Detector = peak.
- Sweep time = auto couple.
- Trace mode = max hold.
- Allow trace to fully stabilize.
- Use the peak marker function to determine the maximum power level in any 100 kHz band segment within the fundamental EBW.

MEASUREMENT PROCEDURE OOB

- Set RBW = 100 kHz.
- Set VBW ≥ 300 kHz.
- Detector = peak.
- Sweep = auto couple.
- Trace Mode = max hold.
- Allow trace to fully stabilize.
- Use the peak marker function to determine the maximum amplitude level.

6.5 AC Power Conducted Emissions

6.5.1 Test Setup

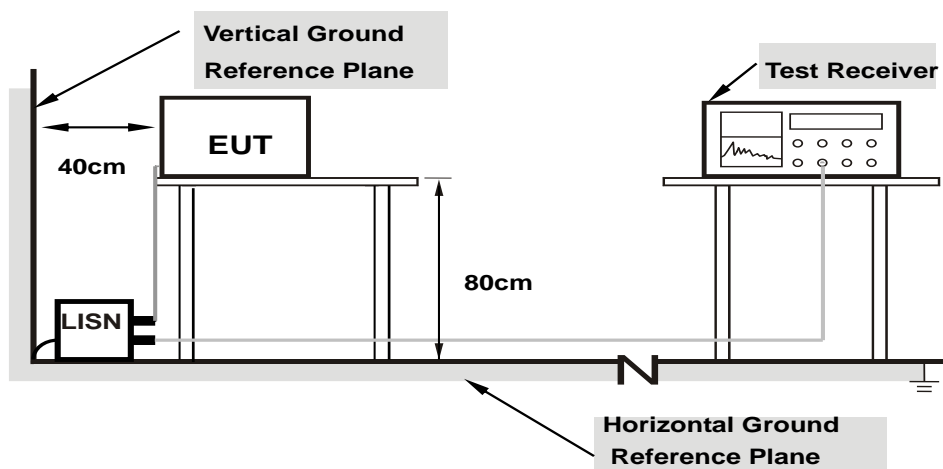

Note: 1.Support units were connected to second LISN.

For the actual test configuration, please refer to the attached file (Test Setup Photo).

6.5.2 Test Procedure

- The EUT was placed on a 0.8 meter to the top of table and placed 0.4 meters from the conducting wall of the shielded room with EUT being connected to the power mains through a line impedance stabilization network (LISN). Other support units were connected to the power mains through another LISN. The two LISNs provide 50 ohm/ 50 uH of coupling impedance for the measuring instrument.
- Both lines of the power mains connected to the EUT were checked for maximum conducted interference.
- The frequency range from 150 kHz to 30 MHz was searched. Emission levels under (Limit – 20 dB) was not recorded.

Note: The resolution bandwidth and video bandwidth of test receiver is 9 kHz for quasi-peak detection (QP) and average detection (AV) at frequency 0.15 MHz-30 MHz.

6.6 Unwanted Emissions below 1 GHz

6.6.1 Test Setup

For Radiated emission below 30 MHz

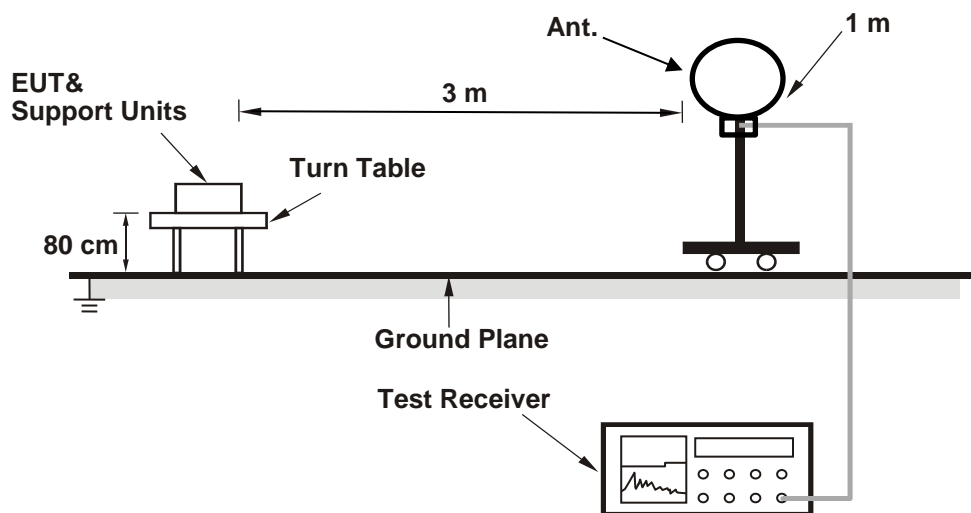

For Radiated emission above 30 MHz

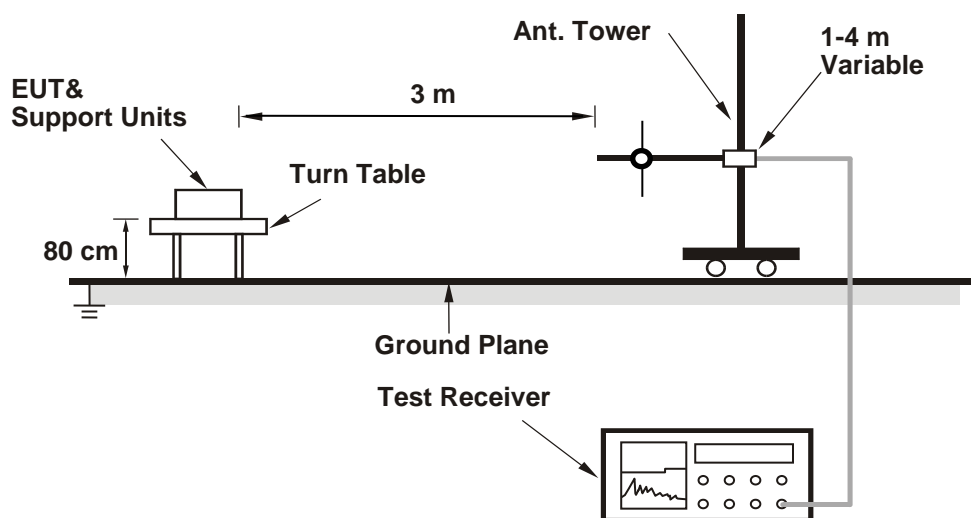

For the actual test configuration, please refer to the attached file (Test Setup Photo).

6.6.2 Test Procedure

For Radiated emission below 30 MHz

- a. The EUT was placed on the top of a rotating table 0.8 meters above the ground at 3 meter chamber room for test. The table was rotated 360 degrees to determine the position of the highest radiation.
- b. The EUT was set 3 meters away from the interference-receiving antenna, which was mounted on the top of a variable-height antenna tower.
- c. Parallel, perpendicular, and ground-parallel orientations of the antenna are set to make the measurement.
- d. For each suspected emission, the EUT was arranged to its worst case and the rotatable table was turned from 0 degrees to 360 degrees to find the maximum reading.
- e. The test-receiver system was set to Quasi-Peak Detect Function and Specified Bandwidth with Maximum Hold Mode, except for the frequency band (9 kHz to 90 kHz and 110 kHz to 490 kHz) set to average detect function and peak detect function.

Notes:

1. The resolution bandwidth and video bandwidth of test receiver/spectrum analyzer is 200 Hz at frequency below 150 kHz.
2. The resolution bandwidth and video bandwidth of test receiver/spectrum analyzer is 9 kHz or 10 kHz at frequency (150 kHz to 30 MHz).
3. All modes of operation were investigated and the worst-case emissions are reported.

For Radiated emission above 30 MHz

- a. The EUT was placed on the top of a rotating table 0.8 meters above the ground at 3 meter chamber room for test. The table was rotated 360 degrees to determine the position of the highest radiation.
- b. The EUT was set 3 meters away from the interference-receiving antenna, which was mounted on the top of a variable-height antenna tower.
- c. The height of antenna is varied from one meter to four meters above the ground to determine the maximum value of the field strength. Both horizontal and vertical polarizations of the antenna are set to make the measurement.
- d. For each suspected emission, the EUT was arranged to its worst case and then the antenna was tuned to heights from 1 meter to 4 meters and the rotatable table was turned from 0 degrees to 360 degrees to find the maximum reading.
- e. The test-receiver system was set to quasi-peak detect function and specified bandwidth with maximum hold mode when the test frequency is below 1 GHz.

Notes:

1. The resolution bandwidth and video bandwidth of test receiver/spectrum analyzer is 120 kHz for Quasi-peak detection (QP) at frequency below 1 GHz.
2. All modes of operation were investigated and the worst-case emissions are reported.

6.7 Unwanted Emissions above 1 GHz

6.7.1 Test Setup

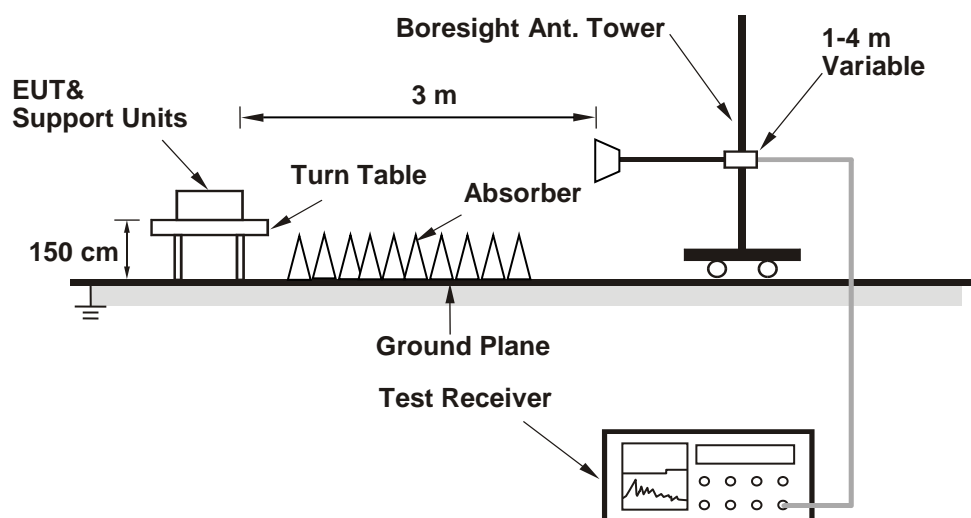

For the actual test configuration, please refer to the attached file (Test Setup Photo).

6.7.2 Test Procedure

- The EUT was placed on the top of a rotating table 1.5 meters above the ground at 3 meter chamber room for test. The table was rotated 360 degrees to determine the position of the highest radiation.
- The EUT was set 3 meters away from the interference-receiving antenna, which was mounted on the top of a variable-height antenna tower.
- The height of antenna is varied from one meter to four meters above the ground to determine the maximum value of the field strength. Both horizontal and vertical polarizations of the antenna are set to make the measurement.
- For each suspected emission, the EUT was arranged to its worst case and then the antenna was tuned to heights from 1 meter to 4 meters and the rotatable table was turned from 0 degrees to 360 degrees to find the maximum reading.
- The test-receiver/spectrum analyzer was set to peak and average detects function and specified bandwidth with maximum hold mode when the test frequency is above 1 GHz. If the peak reading value also meets average limit, measurement with the average detector is unnecessary.

Notes:

- The resolution bandwidth of test receiver/spectrum analyzer is 1 MHz and the video bandwidth is 3 MHz for Peak detection (PK) and Average detection (AV) at frequency above 1 GHz.
- For harmonic signal measurement, the resolution bandwidth of test receiver/spectrum analyzer is 1 MHz and the video bandwidth is $\geq 1/T$ (Duty cycle $< 98\%$) or 10 Hz (Duty cycle $\geq 98\%$) for Average detection (AV) at frequency above 1 GHz.
- All modes of operation were investigated and the worst-case emissions are reported.

7 Test Results of Test Item

7.1 RF Output Power

| | | | | | |
|--------------|---------|---------------------------|--------------|------------|-----------|
| Input Power: | 3.7 Vdc | Environmental Conditions: | 25°C, 76% RH | Tested By: | Dalen Dai |
|--------------|---------|---------------------------|--------------|------------|-----------|

For Peak Power

BT-LE 1M

| Chan. | Chan. Freq. (MHz) | Peak Power (mW) | Peak Power (dBm) | Power Limit (dBm) | Test Result |
|-------|-------------------|-----------------|------------------|-------------------|-------------|
| 0 | 2402 | 4.909 | 6.91 | 30 | Pass |
| 19 | 2440 | 4.831 | 6.84 | 30 | Pass |
| 39 | 2480 | 4.786 | 6.80 | 30 | Pass |

Note: The antenna gain is 2.19 dBi < 6 dBi, so the output power limit shall not be reduced.

BT-LE 2M

| Chan. | Chan. Freq. (MHz) | Peak Power (mW) | Peak Power (dBm) | Power Limit (dBm) | Test Result |
|-------|-------------------|-----------------|------------------|-------------------|-------------|
| 0 | 2402 | 4.92 | 6.92 | 30 | Pass |
| 19 | 2440 | 4.819 | 6.83 | 30 | Pass |
| 39 | 2480 | 4.775 | 6.79 | 30 | Pass |

Note: The antenna gain is 2.19 dBi < 6 dBi, so the output power limit shall not be reduced.

BT-LE 125k

| Chan. | Chan. Freq. (MHz) | Peak Power (mW) | Peak Power (dBm) | Power Limit (dBm) | Test Result |
|-------|-------------------|-----------------|------------------|-------------------|-------------|
| 0 | 2402 | 4.898 | 6.90 | 30 | Pass |
| 19 | 2440 | 4.831 | 6.84 | 30 | Pass |
| 39 | 2480 | 4.775 | 6.79 | 30 | Pass |

Note: The antenna gain is 2.19 dBi < 6 dBi, so the output power limit shall not be reduced.

BT-LE 500k

| Chan. | Chan. Freq. (MHz) | Peak Power (mW) | Peak Power (dBm) | Power Limit (dBm) | Test Result |
|-------|-------------------|-----------------|------------------|-------------------|-------------|
| 0 | 2402 | 4.898 | 6.90 | 30 | Pass |
| 19 | 2440 | 4.819 | 6.83 | 30 | Pass |
| 39 | 2480 | 4.764 | 6.78 | 30 | Pass |

Note: The antenna gain is 2.19 dBi < 6 dBi, so the output power limit shall not be reduced.

For Average Power

BT-LE 1M

| Chan. | Chan. Freq. (MHz) | Average Power (mW) | Average Power (dBm) |
|-------|-------------------|--------------------|---------------------|
| 0 | 2402 | 4.775 | 6.79 |
| 19 | 2440 | 4.688 | 6.71 |
| 39 | 2480 | 4.656 | 6.68 |

BT-LE 2M

| Chan. | Chan. Freq. (MHz) | Average Power (mW) | Average Power (dBm) |
|-------|-------------------|--------------------|---------------------|
| 0 | 2402 | 4.764 | 6.78 |
| 19 | 2440 | 4.677 | 6.70 |
| 39 | 2480 | 4.634 | 6.66 |

BT-LE 125k

| Chan. | Chan. Freq. (MHz) | Average Power (mW) | Average Power (dBm) |
|-------|-------------------|--------------------|---------------------|
| 0 | 2402 | 4.753 | 6.77 |
| 19 | 2440 | 4.667 | 6.69 |
| 39 | 2480 | 4.645 | 6.67 |

BT-LE 500k

| Chan. | Chan. Freq. (MHz) | Average Power (mW) | Average Power (dBm) |
|-------|-------------------|--------------------|---------------------|
| 0 | 2402 | 4.764 | 6.78 |
| 19 | 2440 | 4.677 | 6.70 |
| 39 | 2480 | 4.634 | 6.66 |

7.2 Power Spectral Density

| | | | | | |
|--------------|---------|---------------------------|--------------|------------|-----------|
| Input Power: | 3.7 Vdc | Environmental Conditions: | 25°C, 76% RH | Tested By: | Dalen Dai |
|--------------|---------|---------------------------|--------------|------------|-----------|

BT-LE 1M

| Channel | Freq. (MHz) | PSD (dBm/3kHz) | PSD Limit (dBm/3kHz) | Pass / Fail |
|---------|-------------|----------------|----------------------|-------------|
| 0 | 2402 | -6.7 | 8 | Pass |
| 19 | 2440 | -6.63 | 8 | Pass |
| 39 | 2480 | -6.62 | 8 | Pass |

Note: The antenna gain is 2.19 dBi < 6 dBi, so the power density limit shall not be reduced.

BT-LE 2M

| Channel | Freq. (MHz) | PSD (dBm/3kHz) | PSD Limit (dBm/3kHz) | Pass / Fail |
|---------|-------------|----------------|----------------------|-------------|
| 0 | 2402 | -10.88 | 8 | Pass |
| 19 | 2440 | -10.88 | 8 | Pass |
| 39 | 2480 | -10.89 | 8 | Pass |

Note: The antenna gain is 2.19 dBi < 6 dBi, so the power density limit shall not be reduced.

BT-LE 125k

| Channel | Freq. (MHz) | PSD (dBm/3kHz) | PSD Limit (dBm/3kHz) | Pass / Fail |
|---------|-------------|----------------|----------------------|-------------|
| 0 | 2402 | -0.09 | 8 | Pass |
| 19 | 2440 | 0 | 8 | Pass |
| 39 | 2480 | -0.04 | 8 | Pass |

Note: The antenna gain is 2.19 dBi < 6 dBi, so the power density limit shall not be reduced.

BT-LE 500k

| Channel | Freq. (MHz) | PSD (dBm/3kHz) | PSD Limit (dBm/3kHz) | Pass / Fail |
|---------|-------------|----------------|----------------------|-------------|
| 0 | 2402 | -0.27 | 8 | Pass |
| 19 | 2440 | -0.37 | 8 | Pass |
| 39 | 2480 | -0.33 | 8 | Pass |

Note: The antenna gain is 2.19 dBi < 6 dBi, so the power density limit shall not be reduced.

Spectrum Plot of Maximum Value

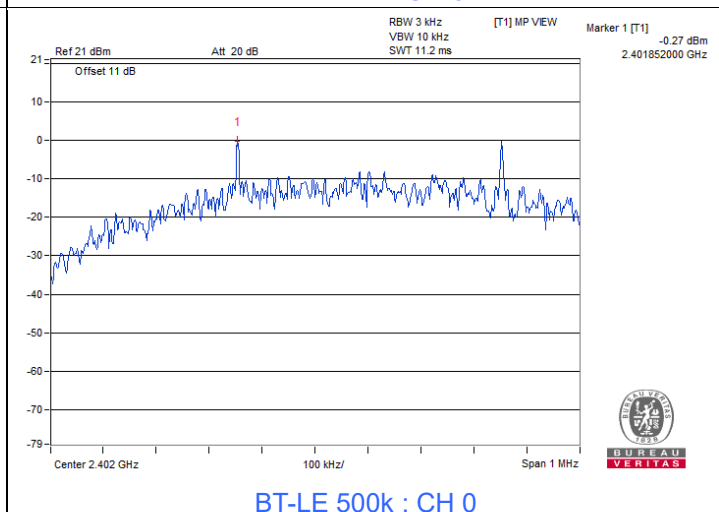
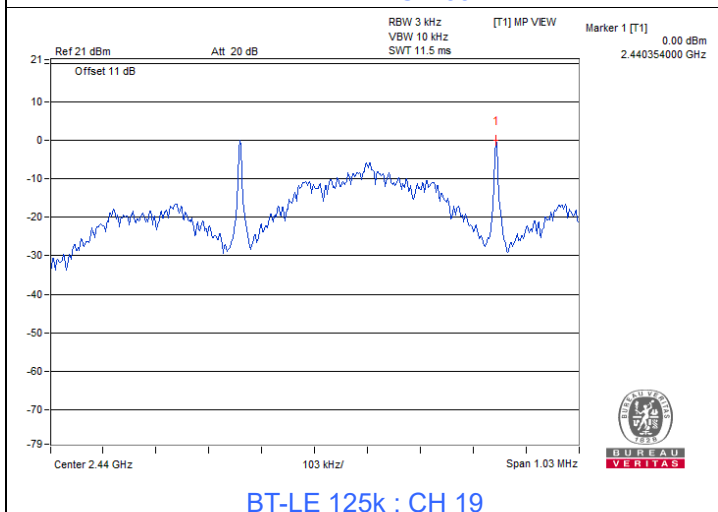
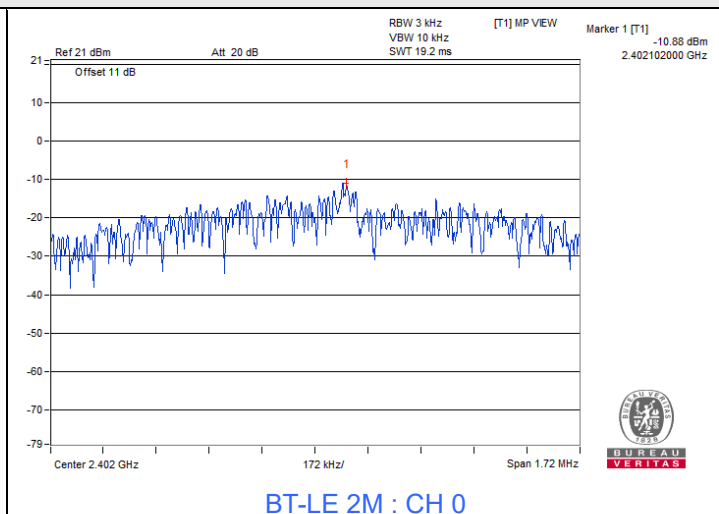
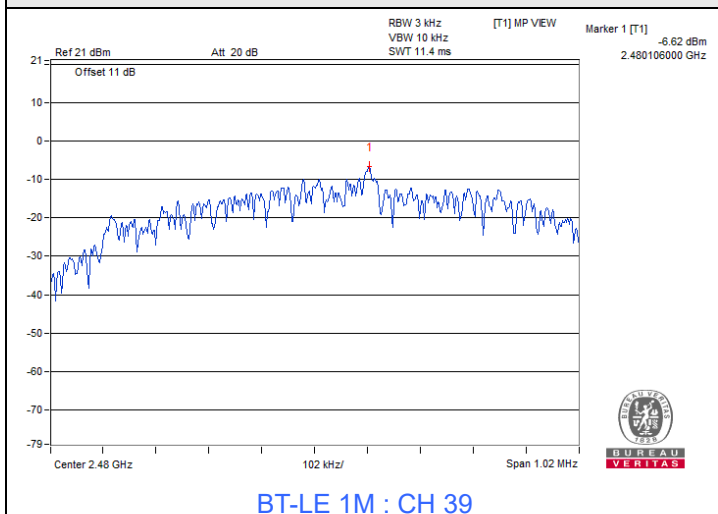

7.3 6 dB Bandwidth

| | | | | | |
|--------------|---------|---------------------------|--------------|------------|-----------|
| Input Power: | 3.7 Vdc | Environmental Conditions: | 25°C, 76% RH | Tested By: | Dalen Dai |
|--------------|---------|---------------------------|--------------|------------|-----------|

BT-LE 1M

| Channel | Frequency (MHz) | 6 dB Bandwidth (MHz) | Minimum Limit (MHz) | Test Result |
|---------|-----------------|----------------------|---------------------|-------------|
| 0 | 2402 | 0.68 | 0.5 | Pass |
| 19 | 2440 | 0.68 | 0.5 | Pass |
| 39 | 2480 | 0.68 | 0.5 | Pass |

BT-LE 2M

| Channel | Frequency (MHz) | 6 dB Bandwidth (MHz) | Minimum Limit (MHz) | Test Result |
|---------|-----------------|----------------------|---------------------|-------------|
| 0 | 2402 | 1.15 | 0.5 | Pass |
| 19 | 2440 | 1.15 | 0.5 | Pass |
| 39 | 2480 | 1.14 | 0.5 | Pass |

BT-LE 125k

| Channel | Frequency (MHz) | 6 dB Bandwidth (MHz) | Minimum Limit (MHz) | Test Result |
|---------|-----------------|----------------------|---------------------|-------------|
| 0 | 2402 | 0.7 | 0.5 | Pass |
| 19 | 2440 | 0.69 | 0.5 | Pass |
| 39 | 2480 | 0.68 | 0.5 | Pass |

BT-LE 500k

| Channel | Frequency (MHz) | 6 dB Bandwidth (MHz) | Minimum Limit (MHz) | Test Result |
|---------|-----------------|----------------------|---------------------|-------------|
| 0 | 2402 | 0.67 | 0.5 | Pass |
| 19 | 2440 | 0.68 | 0.5 | Pass |
| 39 | 2480 | 0.67 | 0.5 | Pass |

Spectrum Plot of Minimum Value

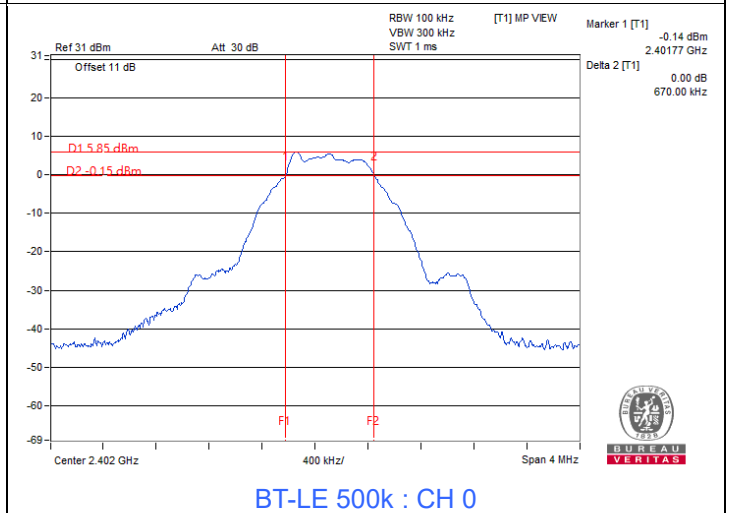
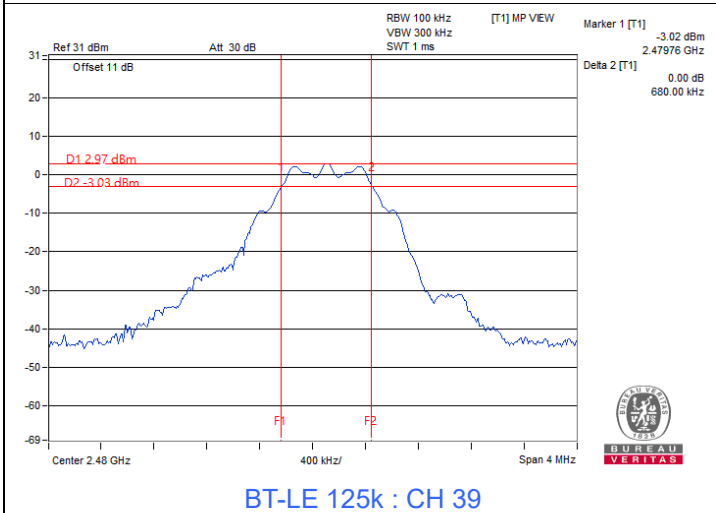
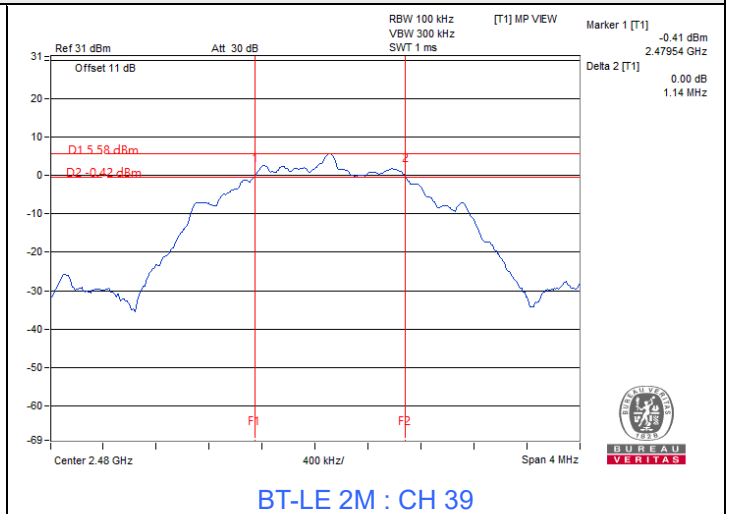
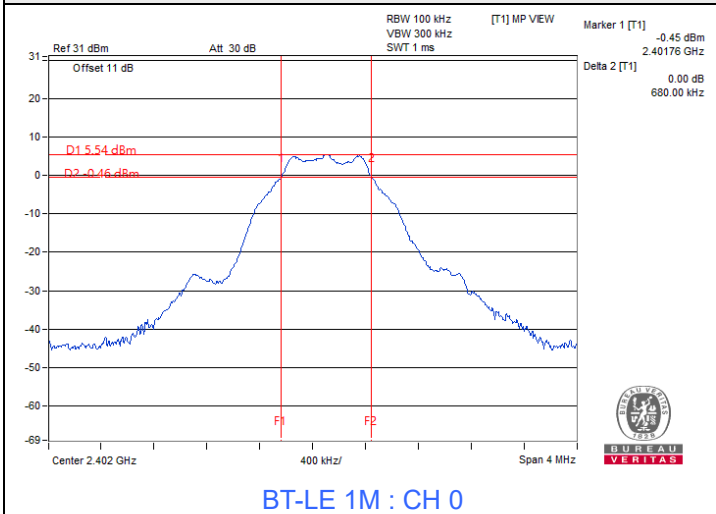



BUREAU VERITAS

7.4 Conducted Out of Band Emissions

| | | | | | |
|--------------|---------|---------------------------|--------------|------------|-----------|
| Input Power: | 3.7 Vdc | Environmental Conditions: | 25°C, 76% RH | Tested By: | Dalen Dai |
|--------------|---------|---------------------------|--------------|------------|-----------|

BT-LE 1M

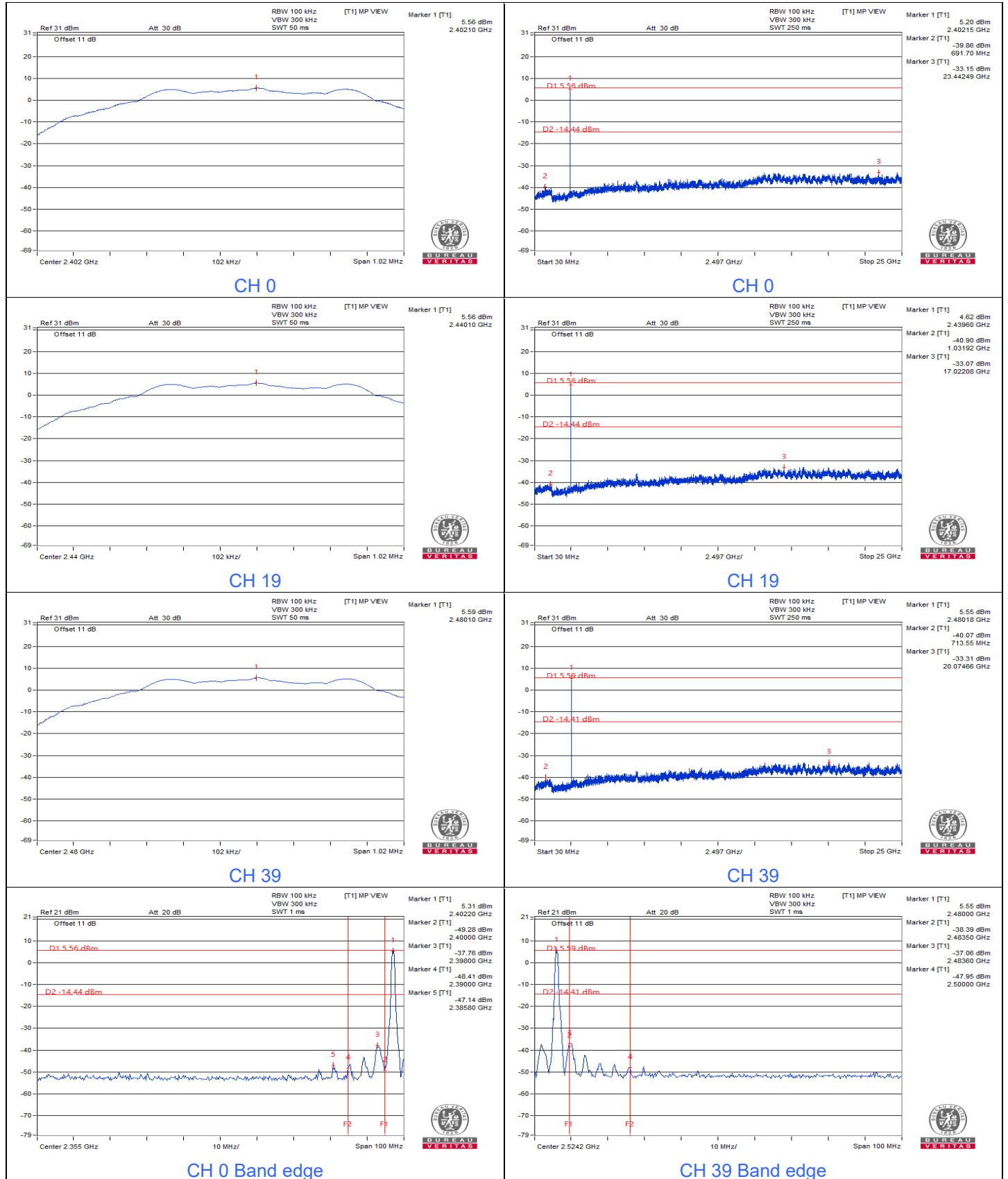

BT-LE 2M

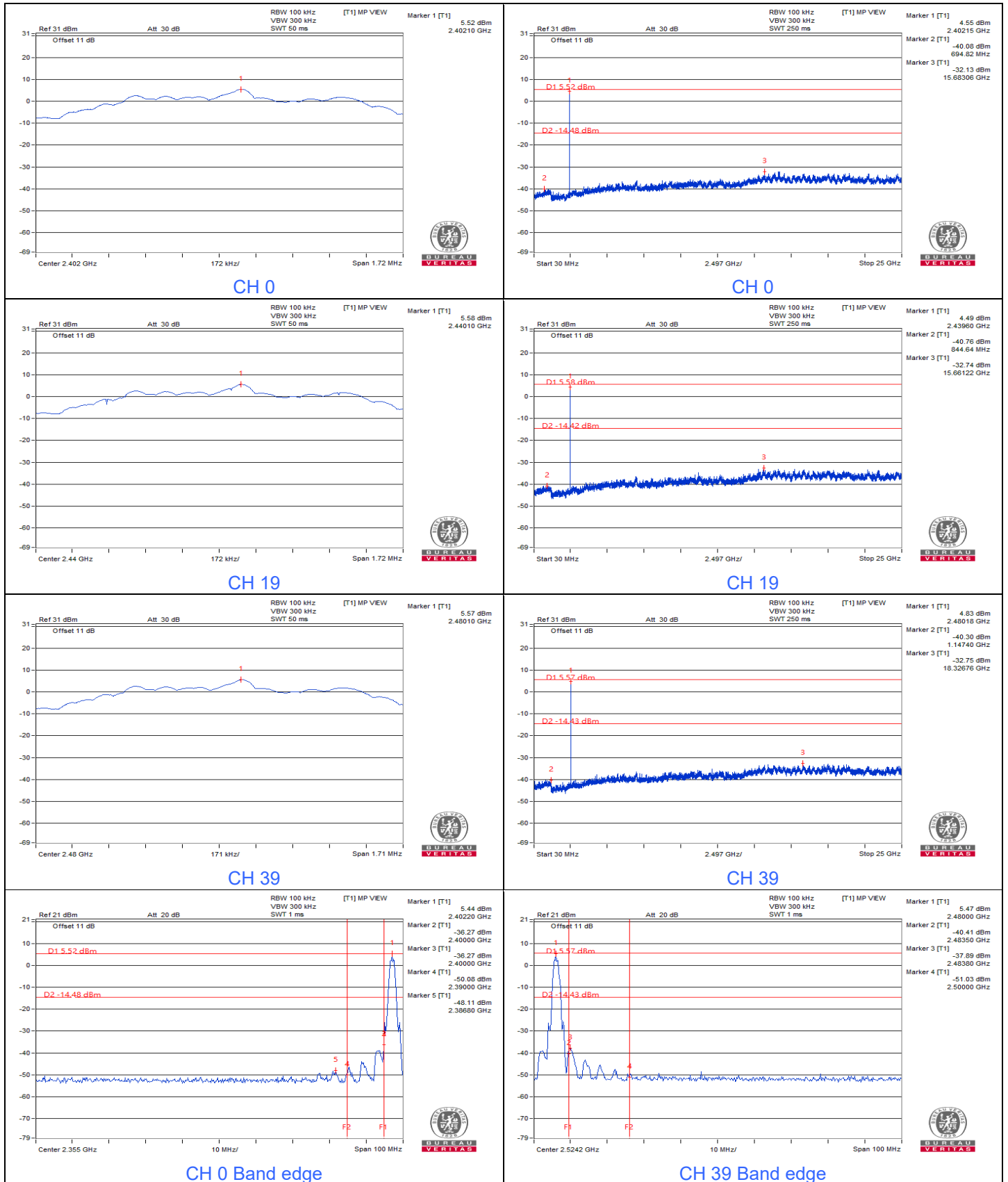



BT-LE 125k

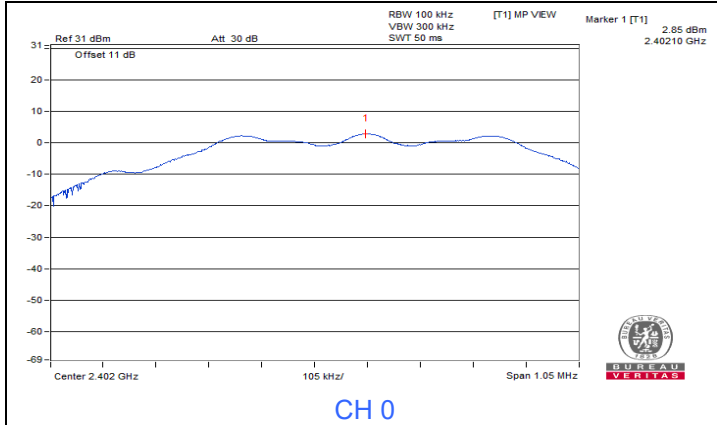

CH 0

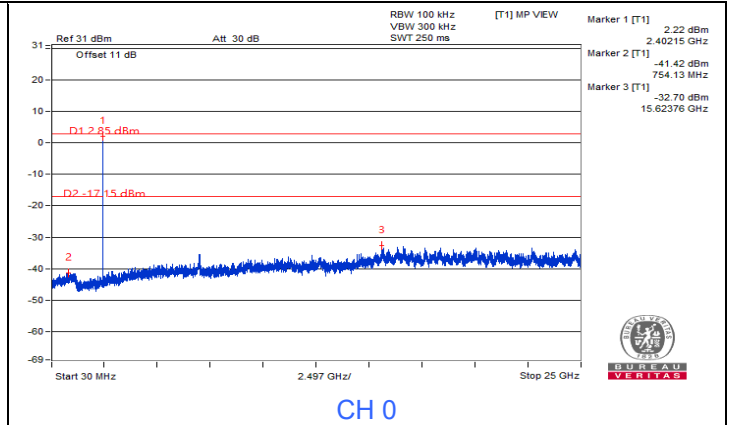

CH 0

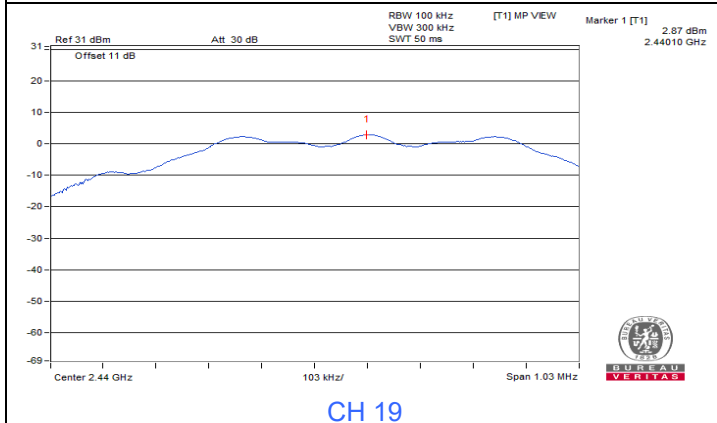

CH 19

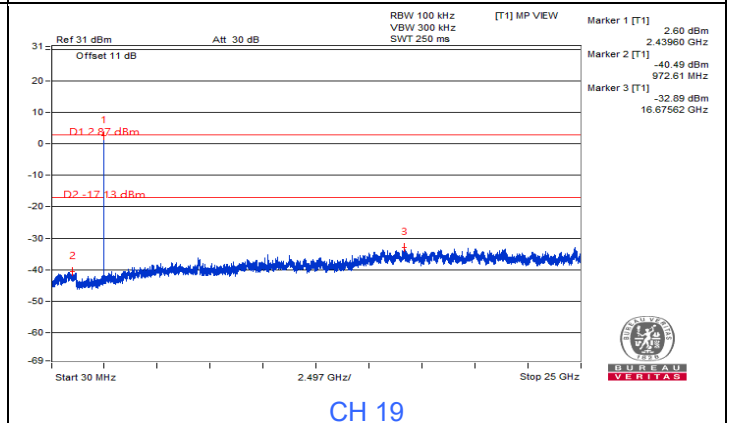

CH 19

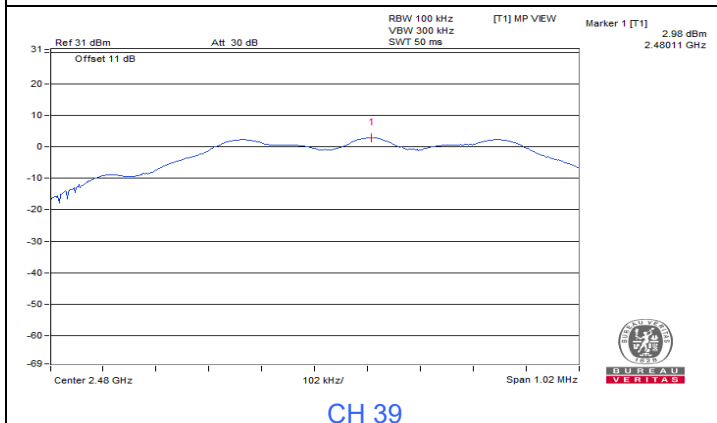

CH 39

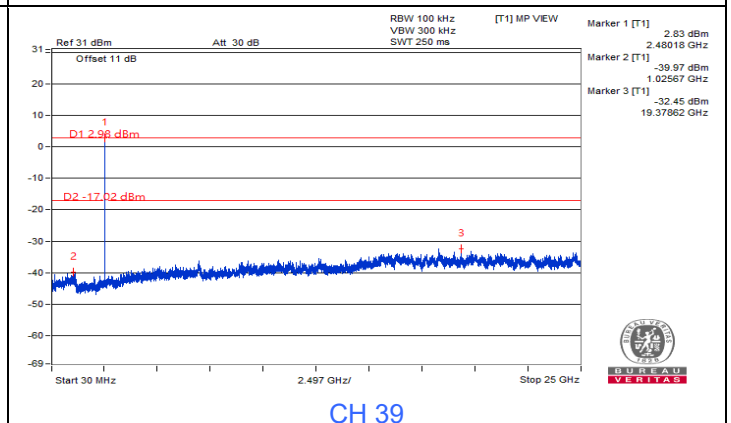

CH 39

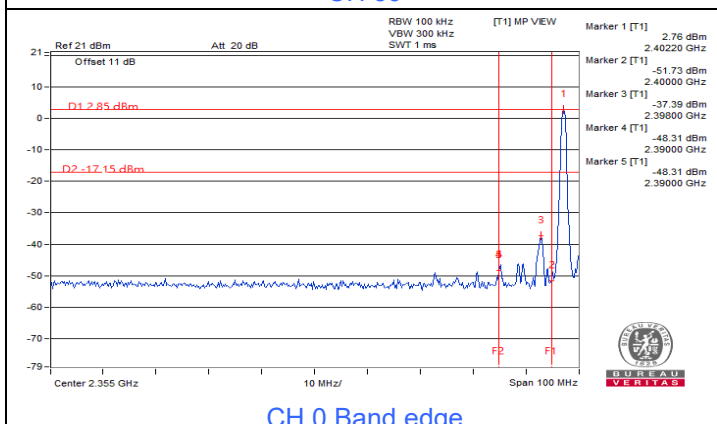

CH 0 Band edge

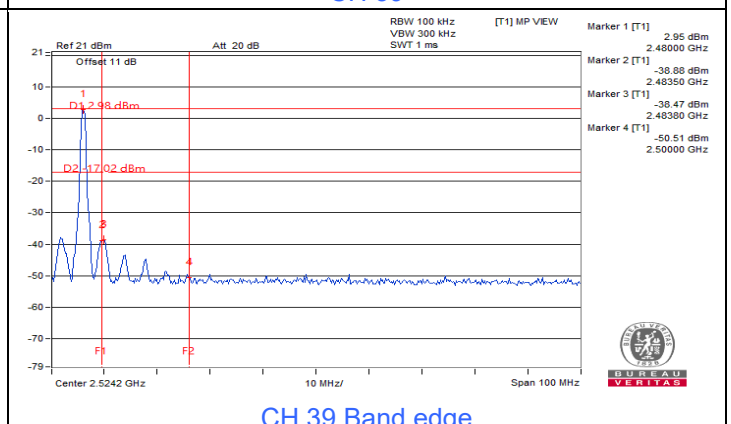

CH 39 Band edge



BT-LE 500k

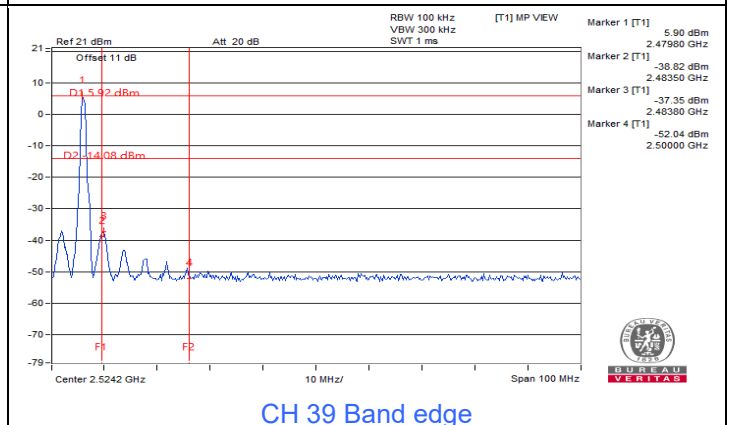
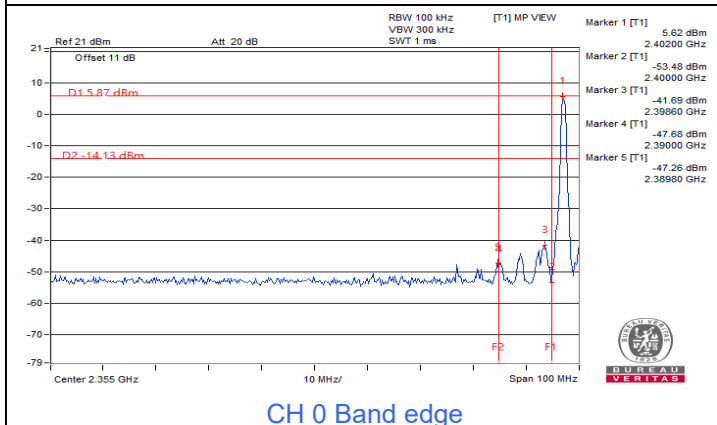
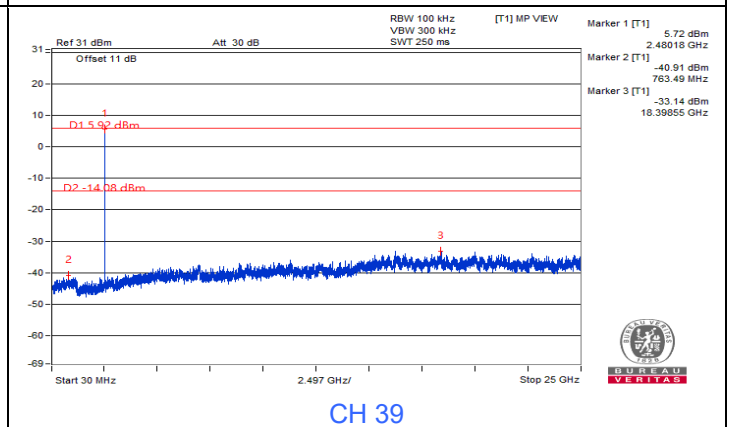
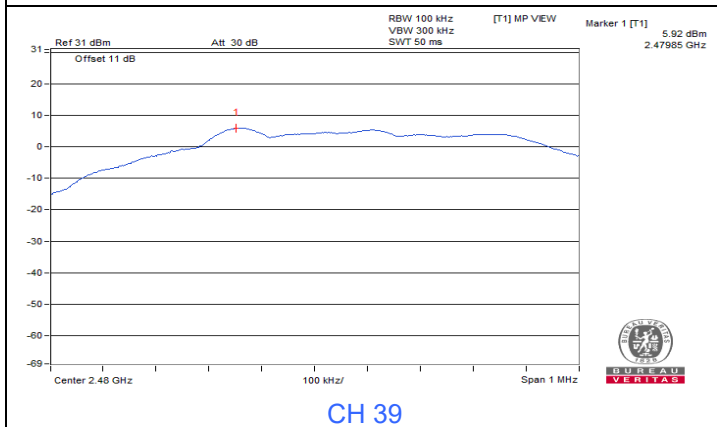
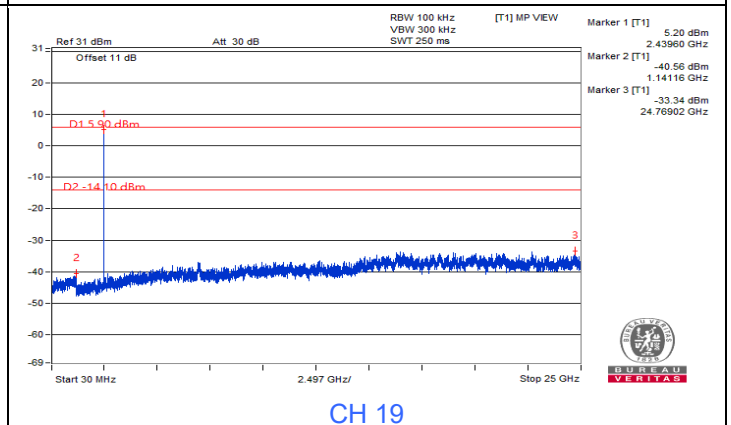
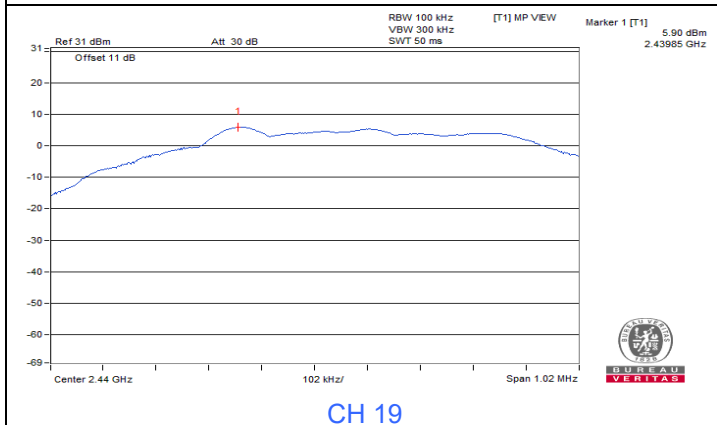
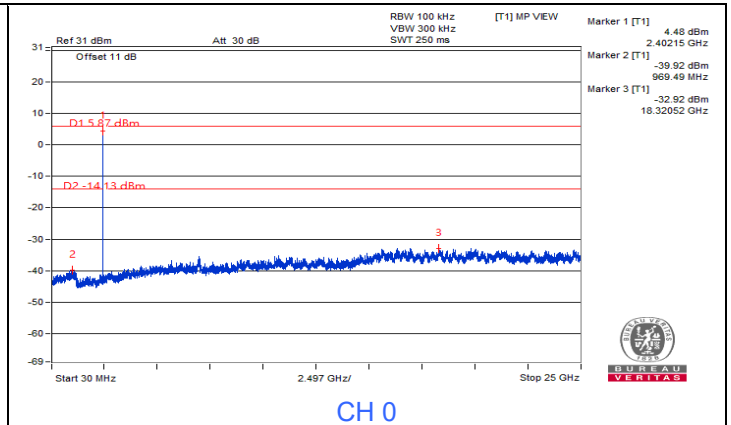
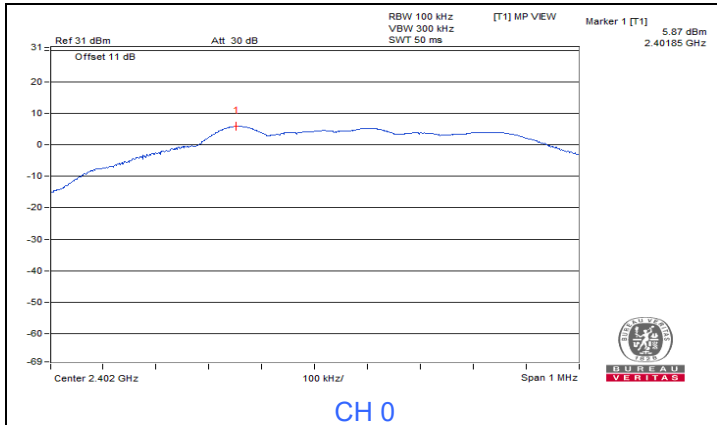

7.5 AC Power Conducted Emissions

Mode B

| | | | |
|-----------------|------------------|------------------------------------------|---------------------------------------|
| Frequency Range | 150 kHz ~ 30 MHz | Detector Function & Resolution Bandwidth | Quasi-Peak (QP) / Average (AV), 9 kHz |
| Input Power | 120 Vac, 60 Hz | Environmental Conditions | 25°C, 75% RH |
| Tested By | William Su | | |

| Phase Of Power : Line (L) | | | | | | | | | | |
|---------------------------|-----------------|------------------------|----------------------|-------|-----------------------|-------|--------------|-------|-------------|--------|
| No | Frequency (MHz) | Correction Factor (dB) | Reading Value (dBuV) | | Emission Level (dBuV) | | Limit (dBuV) | | Margin (dB) | |
| | | | Q.P. | AV. | Q.P. | AV. | Q.P. | AV. | Q.P. | AV. |
| 1 | 0.17400 | 10.04 | 33.35 | 16.96 | 43.39 | 27.00 | 64.77 | 54.77 | -21.38 | -27.77 |
| 2 | 0.25800 | 10.07 | 25.53 | 16.78 | 35.60 | 26.85 | 61.50 | 51.50 | -25.90 | -24.65 |
| 3 | 0.54397 | 10.09 | 29.31 | 24.66 | 39.40 | 34.75 | 56.00 | 46.00 | -16.60 | -11.25 |
| 4 | 0.64800 | 10.09 | 25.00 | 15.83 | 35.09 | 25.92 | 56.00 | 46.00 | -20.91 | -20.08 |
| 5 | 3.68400 | 10.18 | 20.81 | 10.33 | 30.99 | 20.51 | 56.00 | 46.00 | -25.01 | -25.49 |
| 6 | 10.24400 | 10.37 | 15.75 | 10.26 | 26.12 | 20.63 | 60.00 | 50.00 | -33.88 | -29.37 |

Remarks:

1. Q.P. and AV. are abbreviations of quasi-peak and average individually.
2. The emission levels of other frequencies were very low against the limit.
3. Margin value = Emission level – Limit value
4. Correction factor = Insertion loss + Cable loss
5. Emission Level = Correction Factor + Reading Value

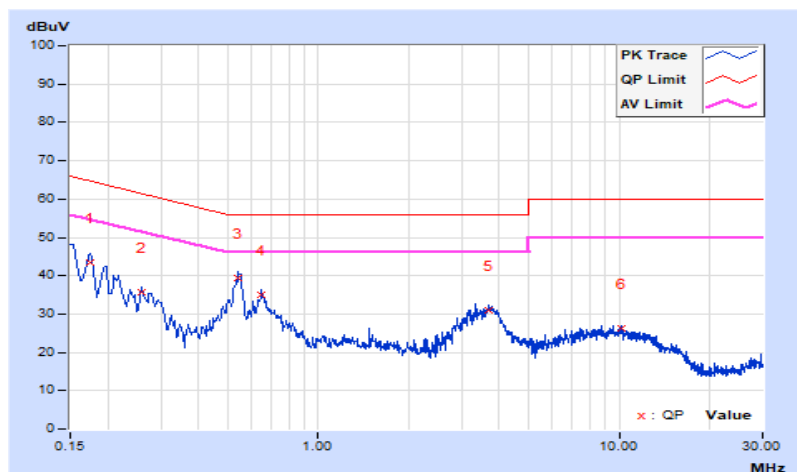

| | | | |
|------------------------|------------------|-----------------------------------------------------|---------------------------------------|
| Frequency Range | 150 kHz ~ 30 MHz | Detector Function & Resolution Bandwidth | Quasi-Peak (QP) / Average (AV), 9 kHz |
| Input Power | 120 Vac, 60 Hz | Environmental Conditions | 25°C, 75% RH |
| Tested By | William Su | | |

| Phase Of Power : Neutral (N) | | | | | | | | | | |
|------------------------------|-----------------|------------------------|----------------------|--------------|-----------------------|--------------|--------------|--------------|---------------|---------------|
| No | Frequency (MHz) | Correction Factor (dB) | Reading Value (dBuV) | | Emission Level (dBuV) | | Limit (dBuV) | | Margin (dB) | |
| | | | Q.P. | AV. | Q.P. | AV. | Q.P. | AV. | Q.P. | AV. |
| 1 | 0.15000 | 10.00 | 38.61 | 24.61 | 48.61 | 34.61 | 66.00 | 56.00 | -17.39 | -21.39 |
| 2 | 0.17400 | 10.04 | 33.27 | 20.15 | 43.31 | 30.19 | 64.77 | 54.77 | -21.46 | -24.58 |
| 3 | 0.54397 | 10.09 | 29.34 | 24.99 | 39.43 | 35.08 | 56.00 | 46.00 | -16.57 | -10.92 |
| 4 | 0.65200 | 10.09 | 25.54 | 19.02 | 35.63 | 29.11 | 56.00 | 46.00 | -20.37 | -16.89 |
| 5 | 3.69200 | 10.18 | 20.67 | 10.39 | 30.85 | 20.57 | 56.00 | 46.00 | -25.15 | -25.43 |
| 6 | 7.44000 | 10.29 | 15.18 | 9.96 | 25.47 | 20.25 | 60.00 | 50.00 | -34.53 | -29.75 |

Remarks:

1. Q.P. and AV. are abbreviations of quasi-peak and average individually.
2. The emission levels of other frequencies were very low against the limit.
3. Margin value = Emission level – Limit value
4. Correction factor = Insertion loss + Cable loss
5. Emission Level = Correction Factor + Reading Value

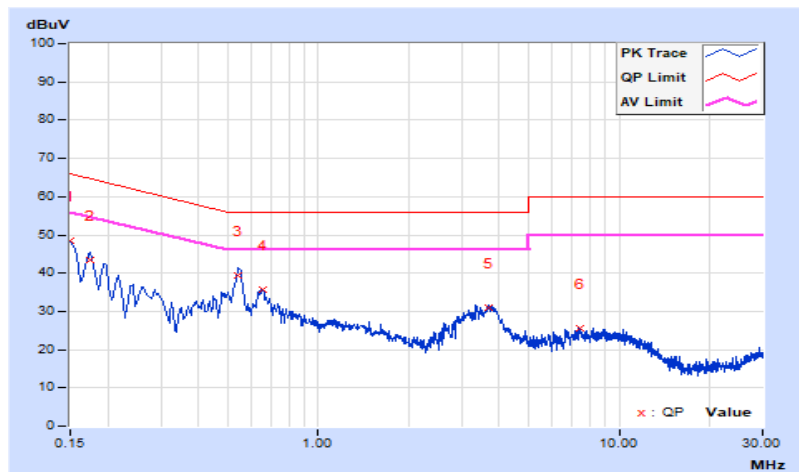

Mode C

| | | | |
|-----------------|------------------|------------------------------------------|---------------------------------------|
| Frequency Range | 150 kHz ~ 30 MHz | Detector Function & Resolution Bandwidth | Quasi-Peak (QP) / Average (AV), 9 kHz |
| Input Power | 120 Vac, 60 Hz | Environmental Conditions | 25°C, 75% RH |
| Tested By | William Su | | |

| Phase Of Power : Line (L) | | | | | | | | | | |
|---------------------------|-----------------|------------------------|----------------------|-------|-----------------------|-------|--------------|-------|-------------|--------|
| No | Frequency (MHz) | Correction Factor (dB) | Reading Value (dBuV) | | Emission Level (dBuV) | | Limit (dBuV) | | Margin (dB) | |
| | | | Q.P. | AV. | Q.P. | AV. | Q.P. | AV. | Q.P. | AV. |
| 1 | 0.26429 | 10.07 | 21.49 | 11.05 | 31.56 | 21.12 | 61.30 | 51.30 | -29.74 | -30.18 |
| 2 | 0.49800 | 10.08 | 22.87 | 16.51 | 32.95 | 26.59 | 56.03 | 46.03 | -23.08 | -19.44 |
| 3 | 0.64388 | 10.09 | 21.14 | 11.35 | 31.23 | 21.44 | 56.00 | 46.00 | -24.77 | -24.56 |
| 4 | 0.99600 | 10.11 | 15.08 | 9.81 | 25.19 | 19.92 | 56.00 | 46.00 | -30.81 | -26.08 |
| 5 | 1.60000 | 10.10 | 14.92 | 8.27 | 25.02 | 18.37 | 56.00 | 46.00 | -30.98 | -27.63 |
| 6 | 2.90000 | 10.14 | 15.89 | 9.37 | 26.03 | 19.51 | 56.00 | 46.00 | -29.97 | -26.49 |

Remarks:

1. Q.P. and AV. are abbreviations of quasi-peak and average individually.
2. The emission levels of other frequencies were very low against the limit.
3. Margin value = Emission level – Limit value
4. Correction factor = Insertion loss + Cable loss
5. Emission Level = Correction Factor + Reading Value

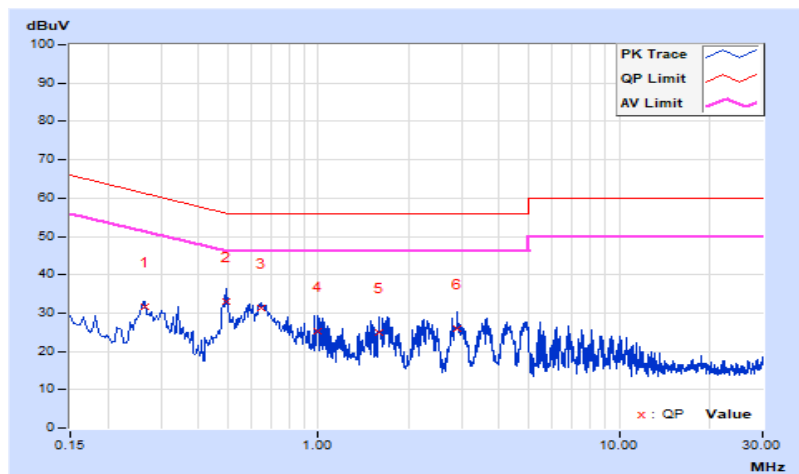

| | | | |
|------------------------|------------------|-----------------------------------------------------|---------------------------------------|
| Frequency Range | 150 kHz ~ 30 MHz | Detector Function & Resolution Bandwidth | Quasi-Peak (QP) / Average (AV), 9 kHz |
| Input Power | 120 Vac, 60 Hz | Environmental Conditions | 25°C, 75% RH |
| Tested By | William Su | | |

| Phase Of Power : Neutral (N) | | | | | | | | | | |
|------------------------------|-----------------|------------------------|----------------------|-------|-----------------------|-------|--------------|-------|-------------|--------|
| No | Frequency (MHz) | Correction Factor (dB) | Reading Value (dBuV) | | Emission Level (dBuV) | | Limit (dBuV) | | Margin (dB) | |
| | | | Q.P. | AV. | Q.P. | AV. | Q.P. | AV. | Q.P. | AV. |
| 1 | 0.30071 | 10.08 | 21.87 | 13.15 | 31.95 | 23.23 | 60.22 | 50.22 | -28.27 | -26.99 |
| 2 | 0.65933 | 10.09 | 22.64 | 12.06 | 32.73 | 22.15 | 56.00 | 46.00 | -23.27 | -23.85 |
| 3 | 1.02000 | 10.11 | 15.16 | 8.51 | 25.27 | 18.62 | 56.00 | 46.00 | -30.73 | -27.38 |
| 4 | 1.62800 | 10.10 | 14.69 | 8.78 | 24.79 | 18.88 | 56.00 | 46.00 | -31.21 | -27.12 |
| 5 | 2.88800 | 10.14 | 15.76 | 9.95 | 25.90 | 20.09 | 56.00 | 46.00 | -30.10 | -25.91 |
| 6 | 4.87600 | 10.22 | 15.47 | 9.59 | 25.69 | 19.81 | 56.00 | 46.00 | -30.31 | -26.19 |

Remarks:

1. Q.P. and AV. are abbreviations of quasi-peak and average individually.
2. The emission levels of other frequencies were very low against the limit.
3. Margin value = Emission level – Limit value
4. Correction factor = Insertion loss + Cable loss
5. Emission Level = Correction Factor + Reading Value

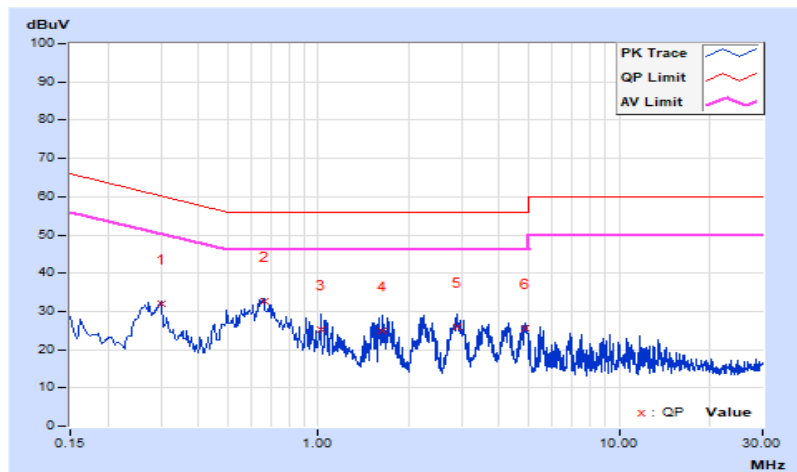

7.6 Unwanted Emissions below 1 GHz

Mode A

| | | | |
|------------------------|----------------|------------------------------------------|-------------------------------|
| RF Mode | BT-LE 2M | Channel | CH 0 : 2402 MHz |
| Frequency Range | 30 MHz ~ 1 GHz | Detector Function & Bandwidth | QP: RB=120kHz, DET=Quasi-Peak |
| Input Power | 3.7 Vdc | Environmental Conditions | 25°C, 75% RH |
| Tested By | William Su | | |

| Antenna Polarity & Test Distance : Horizontal at 3 m | | | | | | | | |
|------------------------------------------------------|-----------------|-------------------------|----------------|-------------|--------------------|----------------------|------------------|--------------------------|
| No | Frequency (MHz) | Emission Level (dBuV/m) | Limit (dBuV/m) | Margin (dB) | Antenna Height (m) | Table Angle (Degree) | Raw Value (dBuV) | Correction Factor (dB/m) |
| 1 | 66.62 | 21.5 QP | 40.0 | -18.5 | 1.05 H | 316 | 31.7 | -10.2 |
| 2 | 96.35 | 22.8 QP | 43.5 | -20.7 | 1.16 H | 273 | 36.8 | -14.0 |
| 3 | 179.91 | 22.1 QP | 43.5 | -21.4 | 1.24 H | 352 | 31.7 | -9.6 |
| 4 | 299.85 | 22.7 QP | 46.0 | -23.3 | 1.30 H | 210 | 29.1 | -6.4 |
| 5 | 371.54 | 23.3 QP | 46.0 | -22.7 | 1.47 H | 237 | 28.1 | -4.8 |
| 6 | 465.63 | 26.9 QP | 46.0 | -19.1 | 1.52 H | 338 | 29.5 | -2.6 |

Remarks:

1. Emission Level(dBuV/m) = Raw Value(dBuV) + Correction Factor(dB/m)
2. Correction Factor(dB/m) = Antenna Factor(dB/m) + Cable Factor(dB) – Pre-Amplifier Factor(dB)
3. Margin value = Emission Level – Limit value
4. The other emission levels were very low against the limit of frequency range 30 MHz ~ 1 GHz.
5. The frequency range 9 kHz ~ 30 MHz: all emissions are more than 20 dB below the limit, therefore do not be recorded in this report.

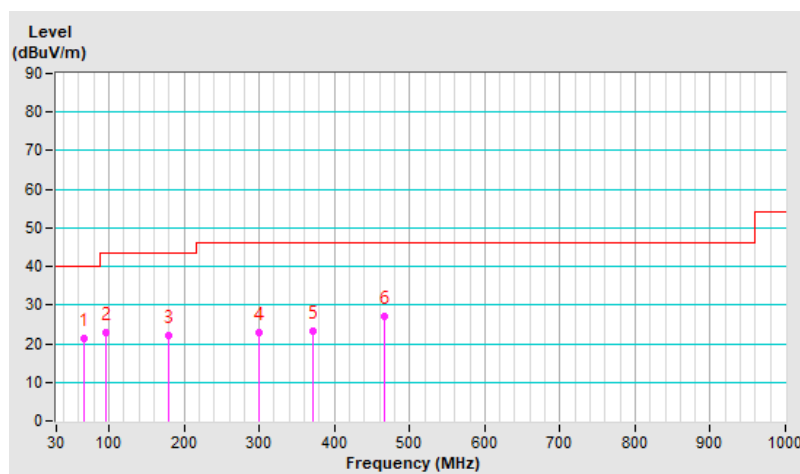

| | | | |
|------------------------|----------------|------------------------------------------|-------------------------------|
| RF Mode | BT-LE 2M | Channel | CH 0 : 2402 MHz |
| Frequency Range | 30 MHz ~ 1 GHz | Detector Function & Bandwidth | QP: RB=120kHz, DET=Quasi-Peak |
| Input Power | 3.7 Vdc | Environmental Conditions | 25°C, 75% RH |
| Tested By | William Su | | |

| Antenna Polarity & Test Distance : Vertical at 3 m | | | | | | | | |
|----------------------------------------------------|-----------------|-------------------------|----------------|-------------|--------------------|----------------------|------------------|--------------------------|
| No | Frequency (MHz) | Emission Level (dBuV/m) | Limit (dBuV/m) | Margin (dB) | Antenna Height (m) | Table Angle (Degree) | Raw Value (dBuV) | Correction Factor (dB/m) |
| 1 | 61.67 | 24.7 QP | 40.0 | -15.3 | 1.06 V | 260 | 34.5 | -9.8 |
| 2 | 182.44 | 21.6 QP | 43.5 | -21.9 | 1.25 V | 148 | 31.5 | -9.9 |
| 3 | 242.48 | 23.0 QP | 46.0 | -23.0 | 1.66 V | 360 | 31.9 | -8.9 |
| 4 | 325.03 | 24.1 QP | 46.0 | -21.9 | 1.05 V | 179 | 29.6 | -5.5 |
| 5 | 420.76 | 24.9 QP | 46.0 | -21.1 | 1.00 V | 102 | 28.5 | -3.6 |
| 6 | 520.38 | 26.7 QP | 46.0 | -19.3 | 1.16 V | 205 | 28.3 | -1.6 |

Remarks:

1. Emission Level(dBuV/m) = Raw Value(dBuV) + Correction Factor(dB/m)
2. Correction Factor(dB/m) = Antenna Factor(dB/m) + Cable Factor(dB) – Pre-Amplifier Factor(dB)
3. Margin value = Emission Level – Limit value
4. The other emission levels were very low against the limit of frequency range 30 MHz ~ 1 GHz.
5. The frequency range 9 kHz ~ 30 MHz: all emissions are more than 20 dB below the limit, therefore do not be recorded in this report.

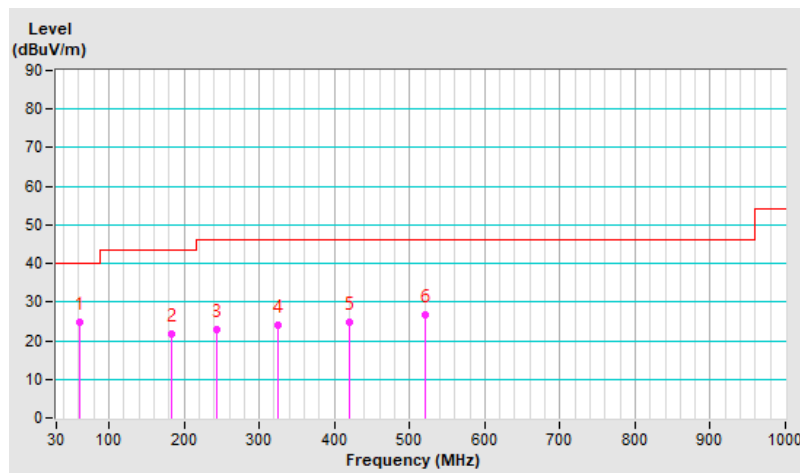

Mode B

| | | | |
|------------------------|----------------|------------------------------------------|-------------------------------|
| Frequency Range | 30 MHz ~ 1 GHz | Detector Function & Bandwidth | QP: RB=120kHz, DET=Quasi-Peak |
| Input Power | 120 Vac, 60 Hz | Environmental Conditions | 25°C, 75% RH |
| Tested By | William Su | | |

| Antenna Polarity & Test Distance : Horizontal at 3 m | | | | | | | | |
|------------------------------------------------------|-----------------|-------------------------|----------------|-------------|--------------------|----------------------|------------------|--------------------------|
| No | Frequency (MHz) | Emission Level (dBuV/m) | Limit (dBuV/m) | Margin (dB) | Antenna Height (m) | Table Angle (Degree) | Raw Value (dBuV) | Correction Factor (dB/m) |
| 1 | 41.30 | 25.7 QP | 40.0 | -14.3 | 1.42 H | 275 | 35.1 | -9.4 |
| 2 | 97.46 | 23.4 QP | 43.5 | -20.1 | 1.69 H | 306 | 37.2 | -13.8 |
| 3 | 148.29 | 24.8 QP | 43.5 | -18.7 | 2.04 H | 280 | 33.5 | -8.7 |
| 4 | 244.66 | 26.0 QP | 46.0 | -20.0 | 1.15 H | 91 | 34.8 | -8.8 |
| 5 | 324.98 | 25.9 QP | 46.0 | -20.1 | 1.38 H | 170 | 31.5 | -5.6 |
| 6 | 455.73 | 26.5 QP | 46.0 | -19.5 | 2.08 H | 17 | 29.2 | -2.7 |

Remarks:

1. Emission Level(dBuV/m) = Raw Value(dBuV) + Correction Factor(dB/m)
2. Correction Factor(dB/m) = Antenna Factor(dB/m) + Cable Factor(dB) – Pre-Amplifier Factor(dB)
3. Margin value = Emission Level – Limit value
4. The other emission levels were very low against the limit of frequency range 30 MHz ~ 1 GHz.
5. The frequency range 9 kHz ~ 30 MHz: all emissions are more than 20 dB below the limit, therefore do not be recorded in this report.

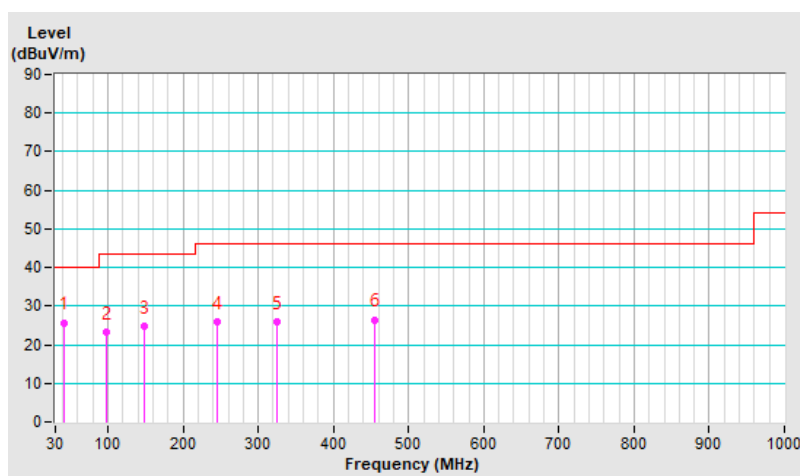

| | | | |
|------------------------|----------------|------------------------------------------|-------------------------------|
| Frequency Range | 30 MHz ~ 1 GHz | Detector Function & Bandwidth | QP: RB=120kHz, DET=Quasi-Peak |
| Input Power | 120 Vac, 60 Hz | Environmental Conditions | 25°C, 75% RH |
| Tested By | William Su | | |

| Antenna Polarity & Test Distance : Vertical at 3 m | | | | | | | | |
|----------------------------------------------------|-----------------|-------------------------|----------------|-------------|--------------------|----------------------|------------------|--------------------------|
| No | Frequency (MHz) | Emission Level (dBuV/m) | Limit (dBuV/m) | Margin (dB) | Antenna Height (m) | Table Angle (Degree) | Raw Value (dBuV) | Correction Factor (dB/m) |
| 1 | 32.89 | 29.6 QP | 40.0 | -10.4 | 1.23 V | 162 | 40.3 | -10.7 |
| 2 | 62.25 | 28.4 QP | 40.0 | -11.6 | 1.42 V | 156 | 38.1 | -9.7 |
| 3 | 96.33 | 31.5 QP | 43.5 | -12.0 | 1.33 V | 291 | 45.5 | -14.0 |
| 4 | 152.85 | 27.9 QP | 43.5 | -15.6 | 2.10 V | 45 | 36.4 | -8.5 |
| 5 | 243.55 | 25.3 QP | 46.0 | -20.7 | 1.58 V | 48 | 34.2 | -8.9 |
| 6 | 325.07 | 24.9 QP | 46.0 | -21.1 | 1.16 V | 171 | 30.4 | -5.5 |

Remarks:

1. Emission Level(dBuV/m) = Raw Value(dBuV) + Correction Factor(dB/m)
2. Correction Factor(dB/m) = Antenna Factor(dB/m) + Cable Factor(dB) – Pre-Amplifier Factor(dB)
3. Margin value = Emission Level – Limit value
4. The other emission levels were very low against the limit of frequency range 30 MHz ~ 1 GHz.
5. The frequency range 9 kHz ~ 30 MHz: all emissions are more than 20 dB below the limit, therefore do not be recorded in this report.

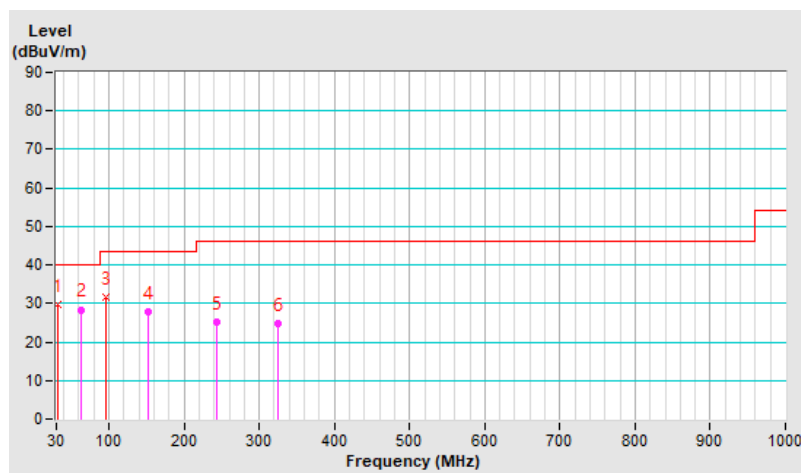

7.7 Unwanted Emissions above 1 GHz

| | | | |
|------------------------|----------------|------------------------------------------|----------------------------------------------------------------------|
| RF Mode | BT-LE 1M | Channel | CH 0 : 2402 MHz |
| Frequency Range | 1 GHz ~ 25 GHz | Detector Function & Bandwidth | PK: RB=1 MHz, VB=3 MHz, DET=Peak AV: RB=1 MHz, VB=3 kHz, DET=Peak |
| Input Power | 3.7 Vdc | Environmental Conditions | 25°C, 75% RH |
| Tested By | Ian Chang | | |

| Antenna Polarity & Test Distance : Horizontal at 3 m | | | | | | | | |
|------------------------------------------------------|-----------------|-------------------------|----------------|-------------|--------------------|----------------------|------------------|--------------------------|
| No | Frequency (MHz) | Emission Level (dBuV/m) | Limit (dBuV/m) | Margin (dB) | Antenna Height (m) | Table Angle (Degree) | Raw Value (dBuV) | Correction Factor (dB/m) |
| 1 | 2390.00 | 52.5 PK | 74.0 | -21.5 | 1.84 H | 37 | 53.7 | -1.2 |
| 2 | 2390.00 | 42.8 AV | 54.0 | -11.2 | 1.84 H | 37 | 44.0 | -1.2 |
| 3 | *2402.00 | 86.9 PK | | | 1.84 H | 37 | 88.1 | -1.2 |
| 4 | *2402.00 | 85.7 AV | | | 1.84 H | 37 | 86.9 | -1.2 |
| 5 | 4804.00 | 54.2 PK | 74.0 | -19.8 | 2.84 H | 331 | 46.2 | 8.0 |
| 6 | 4804.00 | 48.7 AV | 54.0 | -5.3 | 2.84 H | 331 | 40.7 | 8.0 |
| Antenna Polarity & Test Distance : Vertical at 3 m | | | | | | | | |
| No | Frequency (MHz) | Emission Level (dBuV/m) | Limit (dBuV/m) | Margin (dB) | Antenna Height (m) | Table Angle (Degree) | Raw Value (dBuV) | Correction Factor (dB/m) |
| 1 | 2390.00 | 51.8 PK | 74.0 | -22.2 | 3.71 V | 266 | 53.0 | -1.2 |
| 2 | 2390.00 | 42.0 AV | 54.0 | -12.0 | 3.71 V | 266 | 43.2 | -1.2 |
| 3 | *2402.00 | 83.2 PK | | | 3.71 V | 266 | 84.4 | -1.2 |
| 4 | *2402.00 | 82.0 AV | | | 3.71 V | 266 | 83.2 | -1.2 |
| 5 | 4804.00 | 53.8 PK | 74.0 | -20.2 | 1.48 V | 8 | 45.8 | 8.0 |
| 6 | 4804.00 | 48.6 AV | 54.0 | -5.4 | 1.48 V | 8 | 40.6 | 8.0 |

Remarks:

1. Emission Level(dBuV/m) = Raw Value(dBuV) + Correction Factor(dB/m)
2. Correction Factor(dB/m) = Antenna Factor(dB/m) + Cable Factor(dB) – Pre-Amplifier Factor(dB)
3. Margin value = Emission Level – Limit value
4. The other emission levels were very low against the limit.
5. " * ": Fundamental frequency, the limit was restricted at the RF Output Power.



| | | | |
|------------------------|----------------|------------------------------------------|----------------------------------------------------------------------|
| RF Mode | BT-LE 1M | Channel | CH 19 : 2440 MHz |
| Frequency Range | 1 GHz ~ 25 GHz | Detector Function & Bandwidth | PK: RB=1 MHz, VB=3 MHz, DET=Peak AV: RB=1 MHz, VB=3 kHz, DET=Peak |
| Input Power | 3.7 Vdc | Environmental Conditions | 25°C, 75% RH |
| Tested By | Ian Chang | | |

| Antenna Polarity & Test Distance : Horizontal at 3 m | | | | | | | | |
|------------------------------------------------------|-----------------|-------------------------|----------------|-------------|--------------------|----------------------|------------------|--------------------------|
| No | Frequency (MHz) | Emission Level (dBuV/m) | Limit (dBuV/m) | Margin (dB) | Antenna Height (m) | Table Angle (Degree) | Raw Value (dBuV) | Correction Factor (dB/m) |
| 1 | *2440.00 | 85.2 PK | | | 1.81 H | 35 | 86.2 | -1.0 |
| 2 | *2440.00 | 84.7 AV | | | 1.81 H | 35 | 85.7 | -1.0 |
| 3 | 4880.00 | 52.6 PK | 74.0 | -21.4 | 3.25 H | 265 | 44.7 | 7.9 |
| 4 | 4880.00 | 46.6 AV | 54.0 | -7.4 | 3.25 H | 265 | 38.7 | 7.9 |
| Antenna Polarity & Test Distance : Vertical at 3 m | | | | | | | | |
| No | Frequency (MHz) | Emission Level (dBuV/m) | Limit (dBuV/m) | Margin (dB) | Antenna Height (m) | Table Angle (Degree) | Raw Value (dBuV) | Correction Factor (dB/m) |
| 1 | *2440.00 | 81.6 PK | | | 3.69 V | 264 | 82.6 | -1.0 |
| 2 | *2440.00 | 80.4 AV | | | 3.69 V | 264 | 81.4 | -1.0 |
| 3 | 4880.00 | 52.0 PK | 74.0 | -22.0 | 1.68 V | 23 | 44.1 | 7.9 |
| 4 | 4880.00 | 46.1 AV | 54.0 | -7.9 | 1.68 V | 23 | 38.2 | 7.9 |

Remarks:

1. Emission Level(dBuV/m) = Raw Value(dBuV) + Correction Factor(dB/m)
2. Correction Factor(dB/m) = Antenna Factor(dB/m) + Cable Factor(dB) – Pre-Amplifier Factor(dB)
3. Margin value = Emission Level – Limit value
4. The other emission levels were very low against the limit.
5. " * " : Fundamental frequency, the limit was restricted at the RF Output Power.



| | | | |
|------------------------|----------------|------------------------------------------|----------------------------------------------------------------------|
| RF Mode | BT-LE 1M | Channel | CH 39 : 2480 MHz |
| Frequency Range | 1 GHz ~ 25 GHz | Detector Function & Bandwidth | PK: RB=1 MHz, VB=3 MHz, DET=Peak AV: RB=1 MHz, VB=3 kHz, DET=Peak |
| Input Power | 3.7 Vdc | Environmental Conditions | 25°C, 75% RH |
| Tested By | Ian Chang | | |

Antenna Polarity & Test Distance : Horizontal at 3 m

| No | Frequency (MHz) | Emission Level (dBuV/m) | Limit (dBuV/m) | Margin (dB) | Antenna Height (m) | Table Angle (Degree) | Raw Value (dBuV) | Correction Factor (dB/m) |
|----|-----------------|-------------------------|----------------|-------------|--------------------|----------------------|------------------|--------------------------|
| 1 | *2480.00 | 84.5 PK | | | 1.77 H | 34 | 85.5 | -1.0 |
| 2 | *2480.00 | 84.0 AV | | | 1.77 H | 34 | 85.0 | -1.0 |
| 3 | 2483.50 | 57.4 PK | 74.0 | -16.6 | 1.77 H | 34 | 58.4 | -1.0 |
| 4 | 2483.50 | 43.3 AV | 54.0 | -10.7 | 1.77 H | 34 | 44.3 | -1.0 |
| 5 | 4960.00 | 55.1 PK | 74.0 | -18.9 | 3.65 H | 308 | 47.2 | 7.9 |
| 6 | 4960.00 | 50.2 AV | 54.0 | -3.8 | 3.65 H | 308 | 42.3 | 7.9 |

Antenna Polarity & Test Distance : Vertical at 3 m

| No | Frequency (MHz) | Emission Level (dBuV/m) | Limit (dBuV/m) | Margin (dB) | Antenna Height (m) | Table Angle (Degree) | Raw Value (dBuV) | Correction Factor (dB/m) |
|----|-----------------|-------------------------|----------------|-------------|--------------------|----------------------|------------------|--------------------------|
| 1 | *2480.00 | 80.5 PK | | | 3.63 V | 268 | 81.5 | -1.0 |
| 2 | *2480.00 | 79.3 AV | | | 3.63 V | 268 | 80.3 | -1.0 |
| 3 | 2483.50 | 56.0 PK | 74.0 | -18.0 | 3.63 V | 268 | 57.0 | -1.0 |
| 4 | 2483.50 | 42.3 AV | 54.0 | -11.7 | 3.63 V | 268 | 43.3 | -1.0 |
| 5 | 4960.00 | 54.9 PK | 74.0 | -19.1 | 1.68 V | 145 | 47.0 | 7.9 |
| 6 | 4960.00 | 49.7 AV | 54.0 | -4.3 | 1.68 V | 145 | 41.8 | 7.9 |

Remarks:

1. Emission Level(dBuV/m) = Raw Value(dBuV) + Correction Factor(dB/m)
2. Correction Factor(dB/m) = Antenna Factor(dB/m) + Cable Factor(dB) – Pre-Amplifier Factor(dB)
3. Margin value = Emission Level – Limit value
4. The other emission levels were very low against the limit.
5. " * ": Fundamental frequency, the limit was restricted at the RF Output Power.



| | | | |
|------------------------|----------------|------------------------------------------|------------------------------------------------------------------------|
| RF Mode | BT-LE 2M | Channel | CH 0 : 2402 MHz |
| Frequency Range | 1 GHz ~ 25 GHz | Detector Function & Bandwidth | PK: RB=1 MHz, VB=3 MHz, DET=Peak AV: RB=1 MHz, VB=5.1 kHz, DET=Peak |
| Input Power | 3.7 Vdc | Environmental Conditions | 25°C, 75% RH |
| Tested By | Ian Chang | | |

Antenna Polarity & Test Distance : Horizontal at 3 m

| No | Frequency (MHz) | Emission Level (dBuV/m) | Limit (dBuV/m) | Margin (dB) | Antenna Height (m) | Table Angle (Degree) | Raw Value (dBuV) | Correction Factor (dB/m) |
|----|-----------------|-------------------------|----------------|-------------|--------------------|----------------------|------------------|--------------------------|
| 1 | 2390.00 | 52.4 PK | 74.0 | -21.6 | 1.00 H | 25 | 53.6 | -1.2 |
| 2 | 2390.00 | 43.2 AV | 54.0 | -10.8 | 1.00 H | 25 | 44.4 | -1.2 |
| 3 | *2402.00 | 86.4 PK | | | 1.00 H | 25 | 87.6 | -1.2 |
| 4 | *2402.00 | 84.5 AV | | | 1.00 H | 25 | 85.7 | -1.2 |
| 5 | 4804.00 | 54.4 PK | 74.0 | -19.6 | 1.85 H | 243 | 46.4 | 8.0 |
| 6 | 4804.00 | 48.5 AV | 54.0 | -5.5 | 1.85 H | 243 | 40.5 | 8.0 |

Antenna Polarity & Test Distance : Vertical at 3 m

| No | Frequency (MHz) | Emission Level (dBuV/m) | Limit (dBuV/m) | Margin (dB) | Antenna Height (m) | Table Angle (Degree) | Raw Value (dBuV) | Correction Factor (dB/m) |
|----|-----------------|-------------------------|----------------|-------------|--------------------|----------------------|------------------|--------------------------|
| 1 | 2390.00 | 51.8 PK | 74.0 | -22.2 | 3.66 V | 269 | 53.0 | -1.2 |
| 2 | 2390.00 | 42.5 AV | 54.0 | -11.5 | 3.66 V | 269 | 43.7 | -1.2 |
| 3 | *2402.00 | 82.2 PK | | | 3.66 V | 269 | 83.4 | -1.2 |
| 4 | *2402.00 | 81.4 AV | | | 3.66 V | 269 | 82.6 | -1.2 |
| 5 | 4804.00 | 53.9 PK | 74.0 | -20.1 | 1.48 V | 254 | 45.9 | 8.0 |
| 6 | 4804.00 | 47.6 AV | 54.0 | -6.4 | 1.48 V | 254 | 39.6 | 8.0 |

Remarks:

1. Emission Level(dBuV/m) = Raw Value(dBuV) + Correction Factor(dB/m)
2. Correction Factor(dB/m) = Antenna Factor(dB/m) + Cable Factor(dB) – Pre-Amplifier Factor(dB)
3. Margin value = Emission Level – Limit value
4. The other emission levels were very low against the limit.
5. " * ": Fundamental frequency, the limit was restricted at the RF Output Power.



| | | | |
|------------------------|----------------|------------------------------------------|------------------------------------------------------------------------|
| RF Mode | BT-LE 2M | Channel | CH 19 : 2440 MHz |
| Frequency Range | 1 GHz ~ 25 GHz | Detector Function & Bandwidth | PK: RB=1 MHz, VB=3 MHz, DET=Peak AV: RB=1 MHz, VB=5.1 kHz, DET=Peak |
| Input Power | 3.7 Vdc | Environmental Conditions | 25°C, 75% RH |
| Tested By | Ian Chang | | |

| Antenna Polarity & Test Distance : Horizontal at 3 m | | | | | | | | |
|------------------------------------------------------|-----------------|-------------------------|----------------|-------------|--------------------|----------------------|------------------|--------------------------|
| No | Frequency (MHz) | Emission Level (dBuV/m) | Limit (dBuV/m) | Margin (dB) | Antenna Height (m) | Table Angle (Degree) | Raw Value (dBuV) | Correction Factor (dB/m) |
| 1 | *2440.00 | 85.4 PK | | | 1.99 H | 33 | 86.4 | -1.0 |
| 2 | *2440.00 | 83.2 AV | | | 1.99 H | 33 | 84.2 | -1.0 |
| 3 | 4880.00 | 53.2 PK | 74.0 | -20.8 | 1.84 H | 254 | 45.3 | 7.9 |
| 4 | 4880.00 | 47.2 AV | 54.0 | -6.8 | 1.84 H | 254 | 39.3 | 7.9 |

| Antenna Polarity & Test Distance : Vertical at 3 m | | | | | | | | |
|----------------------------------------------------|-----------------|-------------------------|----------------|-------------|--------------------|----------------------|------------------|--------------------------|
| No | Frequency (MHz) | Emission Level (dBuV/m) | Limit (dBuV/m) | Margin (dB) | Antenna Height (m) | Table Angle (Degree) | Raw Value (dBuV) | Correction Factor (dB/m) |
| 1 | *2440.00 | 81.4 PK | | | 3.62 V | 266 | 82.4 | -1.0 |
| 2 | *2440.00 | 79.2 AV | | | 3.62 V | 266 | 80.2 | -1.0 |
| 3 | 4880.00 | 52.7 PK | 74.0 | -21.3 | 1.23 V | 236 | 44.8 | 7.9 |
| 4 | 4880.00 | 46.8 AV | 54.0 | -7.2 | 1.23 V | 236 | 38.9 | 7.9 |

Remarks:

1. Emission Level(dBuV/m) = Raw Value(dBuV) + Correction Factor(dB/m)
2. Correction Factor(dB/m) = Antenna Factor(dB/m) + Cable Factor(dB) – Pre-Amplifier Factor(dB)
3. Margin value = Emission Level – Limit value
4. The other emission levels were very low against the limit.
5. " * " : Fundamental frequency, the limit was restricted at the RF Output Power.



| | | | |
|------------------------|----------------|------------------------------------------|------------------------------------------------------------------------|
| RF Mode | BT-LE 2M | Channel | CH 39 : 2480 MHz |
| Frequency Range | 1 GHz ~ 25 GHz | Detector Function & Bandwidth | PK: RB=1 MHz, VB=3 MHz, DET=Peak AV: RB=1 MHz, VB=5.1 kHz, DET=Peak |
| Input Power | 3.7 Vdc | Environmental Conditions | 25°C, 75% RH |
| Tested By | Ian Chang | | |

Antenna Polarity & Test Distance : Horizontal at 3 m

| No | Frequency (MHz) | Emission Level (dBuV/m) | Limit (dBuV/m) | Margin (dB) | Antenna Height (m) | Table Angle (Degree) | Raw Value (dBuV) | Correction Factor (dB/m) |
|----|-----------------|-------------------------|----------------|-------------|--------------------|----------------------|------------------|--------------------------|
| 1 | *2480.00 | 84.5 PK | | | 1.74 H | 32 | 85.5 | -1.0 |
| 2 | *2480.00 | 82.4 AV | | | 1.74 H | 32 | 83.4 | -1.0 |
| 3 | 2483.50 | 56.9 PK | 74.0 | -17.1 | 1.74 H | 32 | 57.9 | -1.0 |
| 4 | 2483.50 | 44.6 AV | 54.0 | -9.4 | 1.74 H | 32 | 45.6 | -1.0 |
| 5 | 4960.00 | 55.1 PK | 74.0 | -18.9 | 2.12 H | 325 | 47.2 | 7.9 |
| 6 | 4960.00 | 49.0 AV | 54.0 | -5.0 | 2.12 H | 325 | 41.1 | 7.9 |

Antenna Polarity & Test Distance : Vertical at 3 m

| No | Frequency (MHz) | Emission Level (dBuV/m) | Limit (dBuV/m) | Margin (dB) | Antenna Height (m) | Table Angle (Degree) | Raw Value (dBuV) | Correction Factor (dB/m) |
|----|-----------------|-------------------------|----------------|-------------|--------------------|----------------------|------------------|--------------------------|
| 1 | *2480.00 | 80.0 PK | | | 3.66 V | 262 | 81.0 | -1.0 |
| 2 | *2480.00 | 78.9 AV | | | 3.66 V | 262 | 79.9 | -1.0 |
| 3 | 2483.50 | 54.3 PK | 74.0 | -19.7 | 3.66 V | 262 | 55.3 | -1.0 |
| 4 | 2483.50 | 42.4 AV | 54.0 | -11.6 | 3.66 V | 262 | 43.4 | -1.0 |
| 5 | 4960.00 | 54.5 PK | 74.0 | -19.5 | 1.52 V | 230 | 46.6 | 7.9 |
| 6 | 4960.00 | 48.2 AV | 54.0 | -5.8 | 1.52 V | 230 | 40.3 | 7.9 |

Remarks:

1. Emission Level(dBuV/m) = Raw Value(dBuV) + Correction Factor(dB/m)
2. Correction Factor(dB/m) = Antenna Factor(dB/m) + Cable Factor(dB) – Pre-Amplifier Factor(dB)
3. Margin value = Emission Level – Limit value
4. The other emission levels were very low against the limit.
5. " * ": Fundamental frequency, the limit was restricted at the RF Output Power.



| | | | |
|------------------------|----------------|------------------------------------------|-----------------------------------------------------------------------|
| RF Mode | BT-LE 125K | Channel | CH 0 : 2402 MHz |
| Frequency Range | 1 GHz ~ 25 GHz | Detector Function & Bandwidth | PK: RB=1 MHz, VB=3 MHz, DET=Peak AV: RB=1 MHz, VB=510 Hz, DET=Peak |
| Input Power | 3.7 Vdc | Environmental Conditions | 25°C, 75% RH |
| Tested By | Ian Chang | | |

Antenna Polarity & Test Distance : Horizontal at 3 m

| No | Frequency (MHz) | Emission Level (dBuV/m) | Limit (dBuV/m) | Margin (dB) | Antenna Height (m) | Table Angle (Degree) | Raw Value (dBuV) | Correction Factor (dB/m) |
|----|-----------------|-------------------------|----------------|-------------|--------------------|----------------------|------------------|--------------------------|
| 1 | 2390.00 | 52.4 PK | 74.0 | -21.6 | 2.25 H | 18 | 53.6 | -1.2 |
| 2 | 2390.00 | 41.8 AV | 54.0 | -12.2 | 2.25 H | 18 | 43.0 | -1.2 |
| 3 | *2402.00 | 86.3 PK | | | 2.25 H | 18 | 87.5 | -1.2 |
| 4 | *2402.00 | 85.5 AV | | | 2.25 H | 18 | 86.7 | -1.2 |
| 5 | 4804.00 | 54.3 PK | 74.0 | -19.7 | 2.68 H | 335 | 46.3 | 8.0 |
| 6 | 4804.00 | 47.5 AV | 54.0 | -6.5 | 2.68 H | 335 | 39.5 | 8.0 |

Antenna Polarity & Test Distance : Vertical at 3 m

| No | Frequency (MHz) | Emission Level (dBuV/m) | Limit (dBuV/m) | Margin (dB) | Antenna Height (m) | Table Angle (Degree) | Raw Value (dBuV) | Correction Factor (dB/m) |
|----|-----------------|-------------------------|----------------|-------------|--------------------|----------------------|------------------|--------------------------|
| 1 | 2390.00 | 51.9 PK | 74.0 | -22.1 | 3.66 V | 264 | 53.1 | -1.2 |
| 2 | 2390.00 | 41.5 AV | 54.0 | -12.5 | 3.66 V | 264 | 42.7 | -1.2 |
| 3 | *2402.00 | 82.1 PK | | | 3.66 V | 264 | 83.3 | -1.2 |
| 4 | *2402.00 | 81.1 AV | | | 3.66 V | 264 | 82.3 | -1.2 |
| 5 | 4804.00 | 53.7 PK | 74.0 | -20.3 | 1.63 V | 214 | 45.7 | 8.0 |
| 6 | 4804.00 | 47.0 AV | 54.0 | -7.0 | 1.63 V | 214 | 39.0 | 8.0 |

Remarks:

1. Emission Level(dBuV/m) = Raw Value(dBuV) + Correction Factor(dB/m)
2. Correction Factor(dB/m) = Antenna Factor(dB/m) + Cable Factor(dB) – Pre-Amplifier Factor(dB)
3. Margin value = Emission Level – Limit value
4. The other emission levels were very low against the limit.
5. " * ": Fundamental frequency, the limit was restricted at the RF Output Power.



| | | | |
|------------------------|----------------|------------------------------------------|-----------------------------------------------------------------------|
| RF Mode | BT-LE 125K | Channel | CH 19 : 2440 MHz |
| Frequency Range | 1 GHz ~ 25 GHz | Detector Function & Bandwidth | PK: RB=1 MHz, VB=3 MHz, DET=Peak AV: RB=1 MHz, VB=510 Hz, DET=Peak |
| Input Power | 3.7 Vdc | Environmental Conditions | 25°C, 75% RH |
| Tested By | Ian Chang | | |

| Antenna Polarity & Test Distance : Horizontal at 3 m | | | | | | | | |
|------------------------------------------------------|-----------------|-------------------------|----------------|-------------|--------------------|----------------------|------------------|--------------------------|
| No | Frequency (MHz) | Emission Level (dBuV/m) | Limit (dBuV/m) | Margin (dB) | Antenna Height (m) | Table Angle (Degree) | Raw Value (dBuV) | Correction Factor (dB/m) |
| 1 | *2440.00 | 85.5 PK | | | 2.34 H | 35 | 86.5 | -1.0 |
| 2 | *2440.00 | 84.1 AV | | | 2.34 H | 35 | 85.1 | -1.0 |
| 3 | 4880.00 | 53.9 PK | 74.0 | -20.1 | 2.77 H | 198 | 46.0 | 7.9 |
| 4 | 4880.00 | 46.8 AV | 54.0 | -7.2 | 2.77 H | 198 | 38.9 | 7.9 |
| Antenna Polarity & Test Distance : Vertical at 3 m | | | | | | | | |
| No | Frequency (MHz) | Emission Level (dBuV/m) | Limit (dBuV/m) | Margin (dB) | Antenna Height (m) | Table Angle (Degree) | Raw Value (dBuV) | Correction Factor (dB/m) |
| 1 | *2440.00 | 81.2 PK | | | 3.62 V | 264 | 82.2 | -1.0 |
| 2 | *2440.00 | 80.0 AV | | | 3.62 V | 264 | 81.0 | -1.0 |
| 3 | 4880.00 | 52.2 PK | 74.0 | -21.8 | 1.74 V | 154 | 44.3 | 7.9 |
| 4 | 4880.00 | 45.1 AV | 54.0 | -8.9 | 1.74 V | 154 | 37.2 | 7.9 |

Remarks:

1. Emission Level(dBuV/m) = Raw Value(dBuV) + Correction Factor(dB/m)
2. Correction Factor(dB/m) = Antenna Factor(dB/m) + Cable Factor(dB) – Pre-Amplifier Factor(dB)
3. Margin value = Emission Level – Limit value
4. The other emission levels were very low against the limit.
5. " * " : Fundamental frequency, the limit was restricted at the RF Output Power.



| | | | |
|------------------------|----------------|------------------------------------------|-----------------------------------------------------------------------|
| RF Mode | BT-LE 125K | Channel | CH 39 : 2480 MHz |
| Frequency Range | 1 GHz ~ 25 GHz | Detector Function & Bandwidth | PK: RB=1 MHz, VB=3 MHz, DET=Peak AV: RB=1 MHz, VB=510 Hz, DET=Peak |
| Input Power | 3.7 Vdc | Environmental Conditions | 25°C, 75% RH |
| Tested By | Ian Chang | | |

Antenna Polarity & Test Distance : Horizontal at 3 m

| No | Frequency (MHz) | Emission Level (dBuV/m) | Limit (dBuV/m) | Margin (dB) | Antenna Height (m) | Table Angle (Degree) | Raw Value (dBuV) | Correction Factor (dB/m) |
|----|-----------------|-------------------------|----------------|-------------|--------------------|----------------------|------------------|--------------------------|
| 1 | *2480.00 | 84.6 PK | | | 1.95 H | 32 | 85.6 | -1.0 |
| 2 | *2480.00 | 83.7 AV | | | 1.95 H | 32 | 84.7 | -1.0 |
| 3 | 2483.50 | 57.6 PK | 74.0 | -16.4 | 1.95 H | 32 | 58.6 | -1.0 |
| 4 | 2483.50 | 41.9 AV | 54.0 | -12.1 | 1.95 H | 32 | 42.9 | -1.0 |
| 5 | 4960.00 | 56.4 PK | 74.0 | -17.6 | 1.18 H | 328 | 48.5 | 7.9 |
| 6 | 4960.00 | 50.9 AV | 54.0 | -3.1 | 1.18 H | 328 | 43.0 | 7.9 |

Antenna Polarity & Test Distance : Vertical at 3 m

| No | Frequency (MHz) | Emission Level (dBuV/m) | Limit (dBuV/m) | Margin (dB) | Antenna Height (m) | Table Angle (Degree) | Raw Value (dBuV) | Correction Factor (dB/m) |
|----|-----------------|-------------------------|----------------|-------------|--------------------|----------------------|------------------|--------------------------|
| 1 | *2480.00 | 80.4 PK | | | 3.66 V | 268 | 81.4 | -1.0 |
| 2 | *2480.00 | 79.4 AV | | | 3.66 V | 268 | 80.4 | -1.0 |
| 3 | 2483.50 | 54.3 PK | 74.0 | -19.7 | 3.66 V | 268 | 55.3 | -1.0 |
| 4 | 2483.50 | 40.0 AV | 54.0 | -14.0 | 3.66 V | 268 | 41.0 | -1.0 |
| 5 | 4960.00 | 55.1 PK | 74.0 | -18.9 | 1.63 V | 258 | 47.2 | 7.9 |
| 6 | 4960.00 | 50.0 AV | 54.0 | -4.0 | 1.63 V | 258 | 42.1 | 7.9 |

Remarks:

1. Emission Level(dBuV/m) = Raw Value(dBuV) + Correction Factor(dB/m)
2. Correction Factor(dB/m) = Antenna Factor(dB/m) + Cable Factor(dB) – Pre-Amplifier Factor(dB)
3. Margin value = Emission Level – Limit value
4. The other emission levels were very low against the limit.
5. " * ": Fundamental frequency, the limit was restricted at the RF Output Power.



| | | | |
|------------------------|----------------|------------------------------------------|----------------------------------------------------------------------|
| RF Mode | BT-LE 500K | Channel | CH 0 : 2402 MHz |
| Frequency Range | 1 GHz ~ 25 GHz | Detector Function & Bandwidth | PK: RB=1 MHz, VB=3 MHz, DET=Peak AV: RB=1 MHz, VB=1 kHz, DET=Peak |
| Input Power | 3.7 Vdc | Environmental Conditions | 25°C, 75% RH |
| Tested By | Ian Chang | | |

Antenna Polarity & Test Distance : Horizontal at 3 m

| No | Frequency (MHz) | Emission Level (dBuV/m) | Limit (dBuV/m) | Margin (dB) | Antenna Height (m) | Table Angle (Degree) | Raw Value (dBuV) | Correction Factor (dB/m) |
|----|-----------------|-------------------------|----------------|-------------|--------------------|----------------------|------------------|--------------------------|
| 1 | 2390.00 | 52.9 PK | 74.0 | -21.1 | 1.84 H | 32 | 54.1 | -1.2 |
| 2 | 2390.00 | 42.2 AV | 54.0 | -11.8 | 1.84 H | 32 | 43.4 | -1.2 |
| 3 | *2402.00 | 86.6 PK | | | 1.84 H | 32 | 87.8 | -1.2 |
| 4 | *2402.00 | 85.8 AV | | | 1.84 H | 32 | 87.0 | -1.2 |
| 5 | 4804.00 | 54.3 PK | 74.0 | -19.7 | 1.63 H | 31 | 46.3 | 8.0 |
| 6 | 4804.00 | 48.3 AV | 54.0 | -5.7 | 1.63 H | 31 | 40.3 | 8.0 |

Antenna Polarity & Test Distance : Vertical at 3 m

| No | Frequency (MHz) | Emission Level (dBuV/m) | Limit (dBuV/m) | Margin (dB) | Antenna Height (m) | Table Angle (Degree) | Raw Value (dBuV) | Correction Factor (dB/m) |
|----|-----------------|-------------------------|----------------|-------------|--------------------|----------------------|------------------|--------------------------|
| 1 | 2390.00 | 51.8 PK | 74.0 | -22.2 | 3.60 V | 263 | 53.0 | -1.2 |
| 2 | 2390.00 | 41.1 AV | 54.0 | -12.9 | 3.60 V | 263 | 42.3 | -1.2 |
| 3 | *2402.00 | 82.0 PK | | | 3.60 V | 263 | 83.2 | -1.2 |
| 4 | *2402.00 | 81.5 AV | | | 3.60 V | 263 | 82.7 | -1.2 |
| 5 | 4804.00 | 53.3 PK | 74.0 | -20.7 | 1.85 V | 241 | 45.3 | 8.0 |
| 6 | 4804.00 | 47.4 AV | 54.0 | -6.6 | 1.85 V | 241 | 39.4 | 8.0 |

Remarks:

1. Emission Level(dBuV/m) = Raw Value(dBuV) + Correction Factor(dB/m)
2. Correction Factor(dB/m) = Antenna Factor(dB/m) + Cable Factor(dB) – Pre-Amplifier Factor(dB)
3. Margin value = Emission Level – Limit value
4. The other emission levels were very low against the limit.
5. " * ": Fundamental frequency, the limit was restricted at the RF Output Power.



| | | | |
|------------------------|----------------|------------------------------------------|----------------------------------------------------------------------|
| RF Mode | BT-LE 500K | Channel | CH 19 : 2440 MHz |
| Frequency Range | 1 GHz ~ 25 GHz | Detector Function & Bandwidth | PK: RB=1 MHz, VB=3 MHz, DET=Peak AV: RB=1 MHz, VB=1 kHz, DET=Peak |
| Input Power | 3.7 Vdc | Environmental Conditions | 25°C, 75% RH |
| Tested By | Ian Chang | | |

Antenna Polarity & Test Distance : Horizontal at 3 m

| No | Frequency (MHz) | Emission Level (dBuV/m) | Limit (dBuV/m) | Margin (dB) | Antenna Height (m) | Table Angle (Degree) | Raw Value (dBuV) | Correction Factor (dB/m) |
|----|-----------------|-------------------------|----------------|-------------|--------------------|----------------------|------------------|--------------------------|
| 1 | *2440.00 | 85.0 PK | | | 1.78 H | 36 | 86.0 | -1.0 |
| 2 | *2440.00 | 83.9 AV | | | 1.78 H | 36 | 84.9 | -1.0 |
| 3 | 4880.00 | 49.2 PK | 74.0 | -24.8 | 2.35 H | 339 | 41.3 | 7.9 |
| 4 | 4880.00 | 47.9 AV | 54.0 | -6.1 | 2.35 H | 339 | 40.0 | 7.9 |

Antenna Polarity & Test Distance : Vertical at 3 m

| No | Frequency (MHz) | Emission Level (dBuV/m) | Limit (dBuV/m) | Margin (dB) | Antenna Height (m) | Table Angle (Degree) | Raw Value (dBuV) | Correction Factor (dB/m) |
|----|-----------------|-------------------------|----------------|-------------|--------------------|----------------------|------------------|--------------------------|
| 1 | *2440.00 | 81.1 PK | | | 3.69 V | 268 | 82.1 | -1.0 |
| 2 | *2440.00 | 80.0 AV | | | 3.69 V | 268 | 81.0 | -1.0 |
| 3 | 4880.00 | 51.9 PK | 74.0 | -22.1 | 1.74 V | 156 | 44.0 | 7.9 |
| 4 | 4880.00 | 46.6 AV | 54.0 | -7.4 | 1.74 V | 156 | 38.7 | 7.9 |

Remarks:

1. Emission Level(dBuV/m) = Raw Value(dBuV) + Correction Factor(dB/m)
2. Correction Factor(dB/m) = Antenna Factor(dB/m) + Cable Factor(dB) – Pre-Amplifier Factor(dB)
3. Margin value = Emission Level – Limit value
4. The other emission levels were very low against the limit.
5. " * " : Fundamental frequency, the limit was restricted at the RF Output Power.



| | | | |
|------------------------|----------------|------------------------------------------|----------------------------------------------------------------------|
| RF Mode | BT-LE 500K | Channel | CH 39 : 2480 MHz |
| Frequency Range | 1 GHz ~ 25 GHz | Detector Function & Bandwidth | PK: RB=1 MHz, VB=3 MHz, DET=Peak AV: RB=1 MHz, VB=1 kHz, DET=Peak |
| Input Power | 3.7 Vdc | Environmental Conditions | 25°C, 75% RH |
| Tested By | Ian Chang | | |

Antenna Polarity & Test Distance : Horizontal at 3 m

| No | Frequency (MHz) | Emission Level (dBuV/m) | Limit (dBuV/m) | Margin (dB) | Antenna Height (m) | Table Angle (Degree) | Raw Value (dBuV) | Correction Factor (dB/m) |
|----|-----------------|-------------------------|----------------|-------------|--------------------|----------------------|------------------|--------------------------|
| 1 | *2480.00 | 84.5 PK | | | 1.45 H | 249 | 85.5 | -1.0 |
| 2 | *2480.00 | 83.5 AV | | | 1.45 H | 249 | 84.5 | -1.0 |
| 3 | 2483.50 | 56.8 PK | 74.0 | -17.2 | 1.45 H | 249 | 57.8 | -1.0 |
| 4 | 2483.50 | 42.3 AV | 54.0 | -11.7 | 1.45 H | 249 | 43.3 | -1.0 |
| 5 | 4960.00 | 56.5 PK | 74.0 | -17.5 | 1.17 H | 325 | 48.6 | 7.9 |
| 6 | 4960.00 | 51.3 AV | 54.0 | -2.7 | 1.17 H | 325 | 43.4 | 7.9 |

Antenna Polarity & Test Distance : Vertical at 3 m

| No | Frequency (MHz) | Emission Level (dBuV/m) | Limit (dBuV/m) | Margin (dB) | Antenna Height (m) | Table Angle (Degree) | Raw Value (dBuV) | Correction Factor (dB/m) |
|----|-----------------|-------------------------|----------------|-------------|--------------------|----------------------|------------------|--------------------------|
| 1 | *2480.00 | 80.0 PK | | | 3.67 V | 261 | 81.0 | -1.0 |
| 2 | *2480.00 | 79.0 AV | | | 3.67 V | 261 | 80.0 | -1.0 |
| 3 | 2483.50 | 55.0 PK | 74.0 | -19.0 | 3.67 V | 261 | 56.0 | -1.0 |
| 4 | 2483.50 | 41.3 AV | 54.0 | -12.7 | 3.67 V | 261 | 42.3 | -1.0 |
| 5 | 4960.00 | 55.2 PK | 74.0 | -18.8 | 1.42 V | 136 | 47.3 | 7.9 |
| 6 | 4960.00 | 50.3 AV | 54.0 | -3.7 | 1.42 V | 136 | 42.4 | 7.9 |

Remarks:

1. Emission Level(dBuV/m) = Raw Value(dBuV) + Correction Factor(dB/m)
2. Correction Factor(dB/m) = Antenna Factor(dB/m) + Cable Factor(dB) – Pre-Amplifier Factor(dB)
3. Margin value = Emission Level – Limit value
4. The other emission levels were very low against the limit.
5. " * ": Fundamental frequency, the limit was restricted at the RF Output Power.

Plot of Band Edge

| | | | |
|-----------------|--------------------|-------------------------------|----------------------------------------------------------------------|
| Frequency Range | 2.31 GHz ~ 2.5 GHz | Detector Function & Bandwidth | PK: RB=1 MHz, VB=3 MHz, DET=Peak AV: RB=1 MHz, VB=3 kHz, DET=Peak |
|-----------------|--------------------|-------------------------------|----------------------------------------------------------------------|

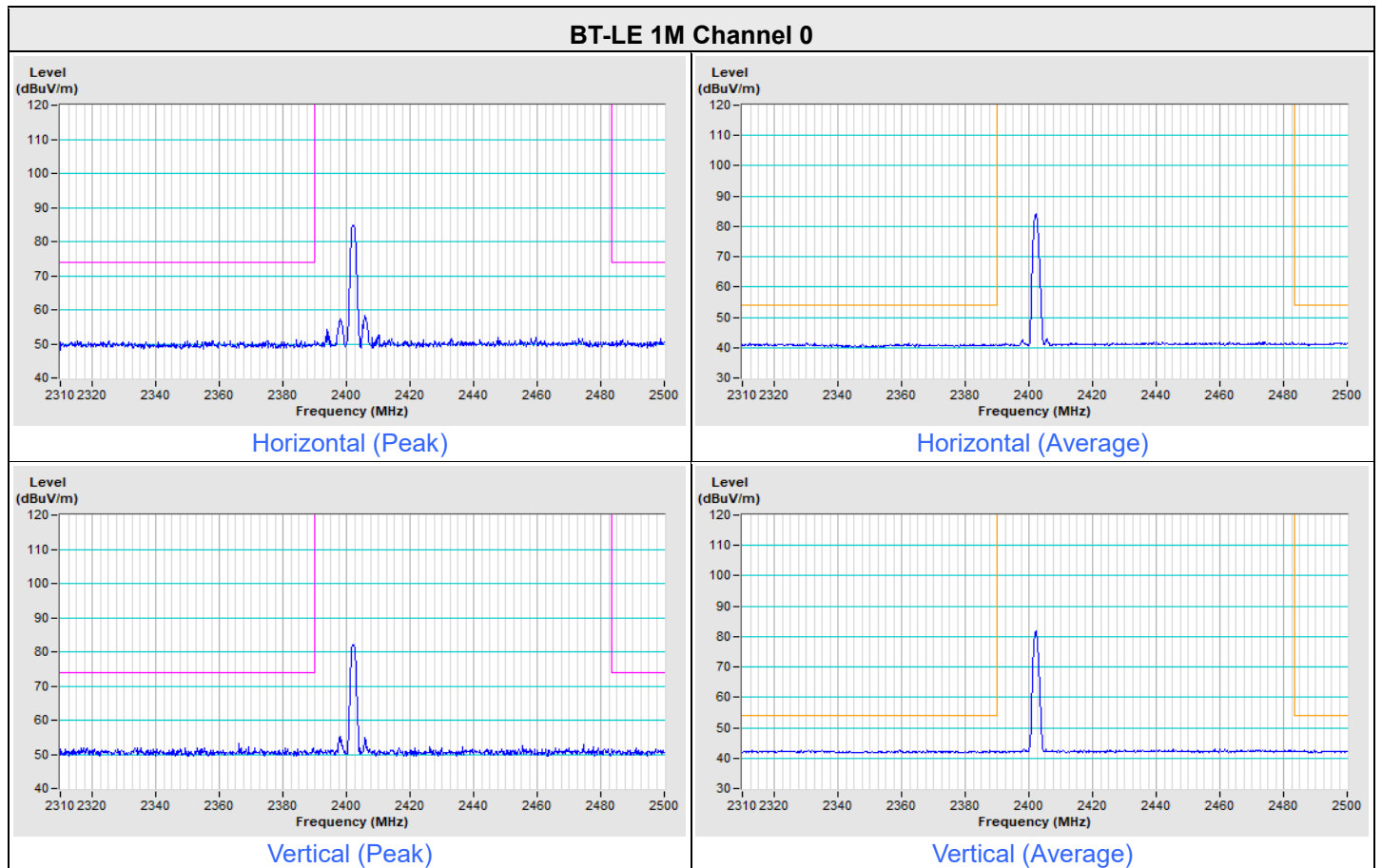

BT-LE 1M Channel 39

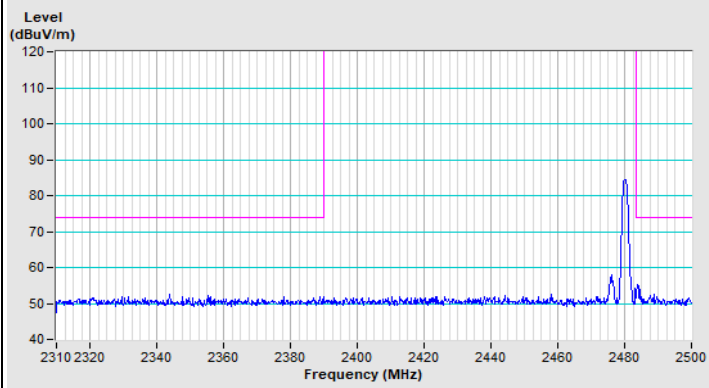

Horizontal (Peak)

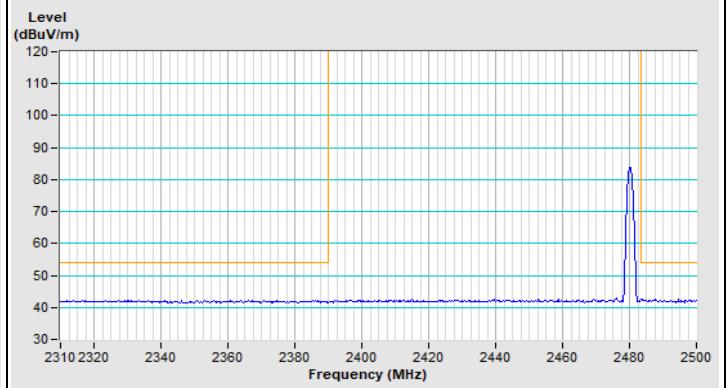

Horizontal (Average)

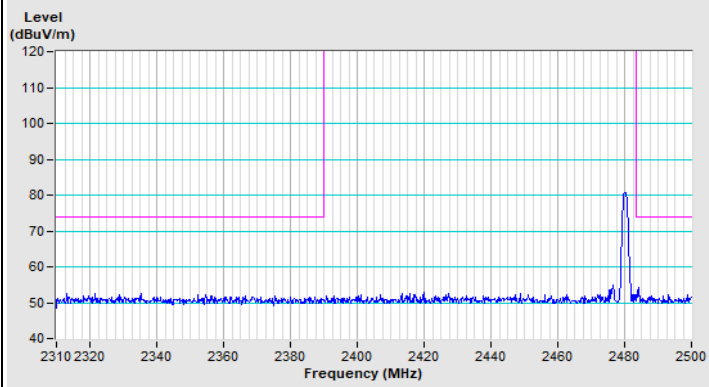

Vertical (Peak)

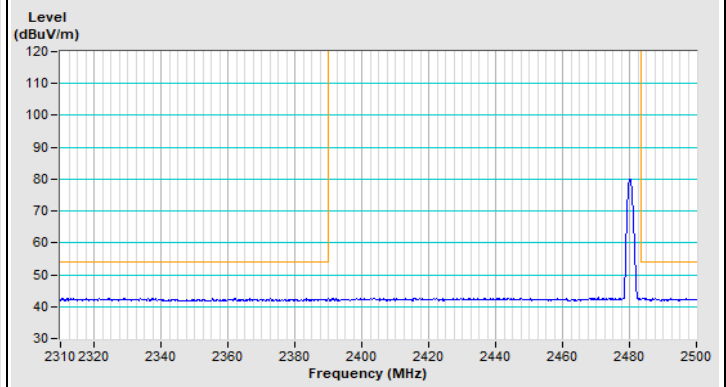

Vertical (Average)

| | | | |
|-----------------|--------------------|-------------------------------|------------------------------------------------------------------------|
| Frequency Range | 2.31 GHz ~ 2.5 GHz | Detector Function & Bandwidth | PK: RB=1 MHz, VB=3 MHz, DET=Peak AV: RB=1 MHz, VB=5.1 kHz, DET=Peak |
|-----------------|--------------------|-------------------------------|------------------------------------------------------------------------|

BT-LE 2M Channel 0

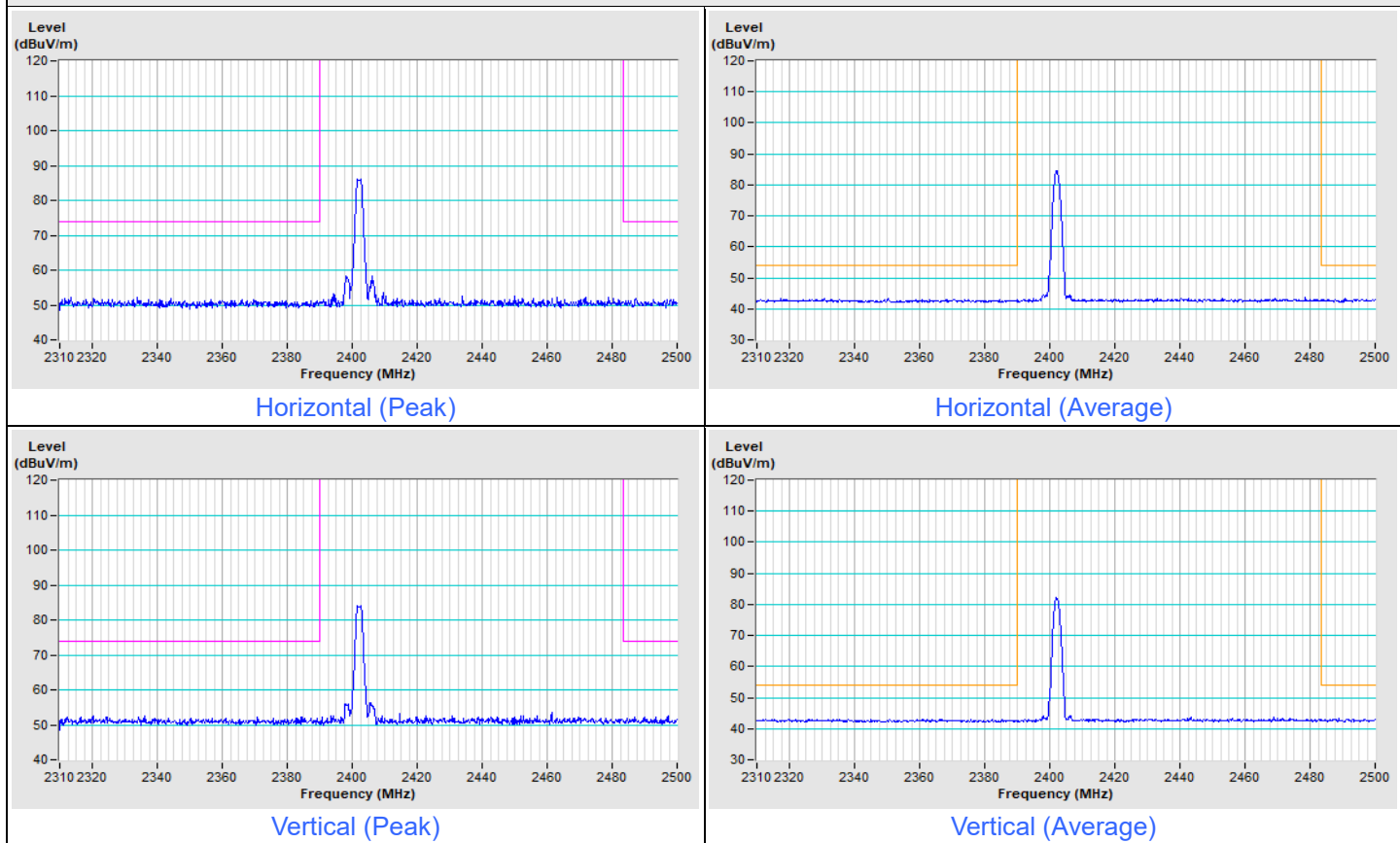

BT-LE 2M Channel 39

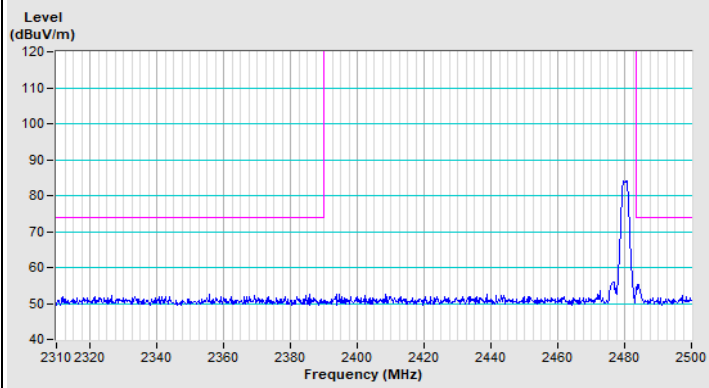

Horizontal (Peak)

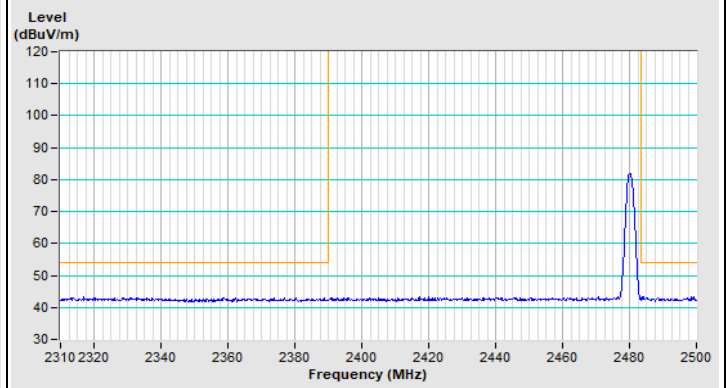

Horizontal (Average)

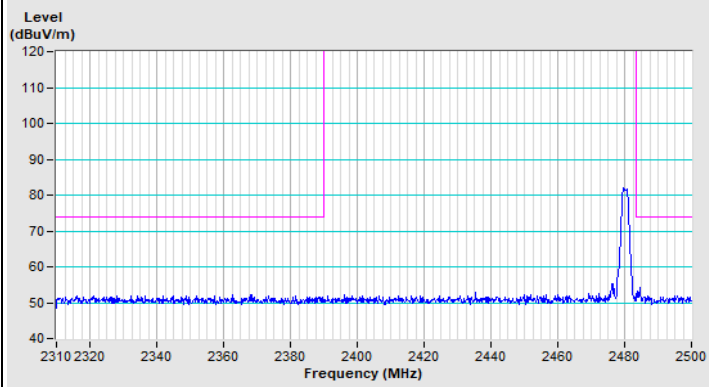

Vertical (Peak)

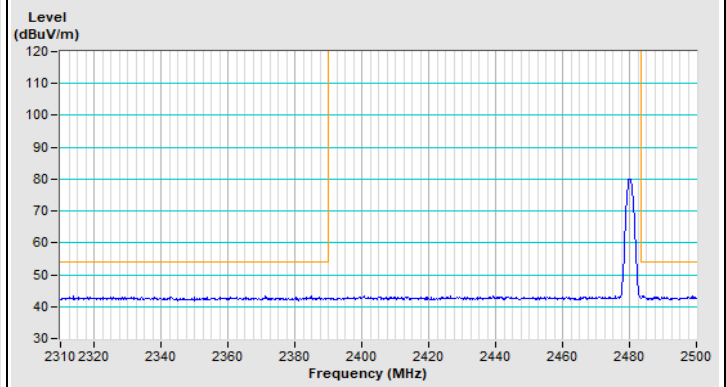

Vertical (Average)

| | | | |
|-----------------|--------------------|-------------------------------|-----------------------------------------------------------------------|
| Frequency Range | 2.31 GHz ~ 2.5 GHz | Detector Function & Bandwidth | PK: RB=1 MHz, VB=3 MHz, DET=Peak AV: RB=1 MHz, VB=510 Hz, DET=Peak |
|-----------------|--------------------|-------------------------------|-----------------------------------------------------------------------|

BT-LE 125K Channel 0

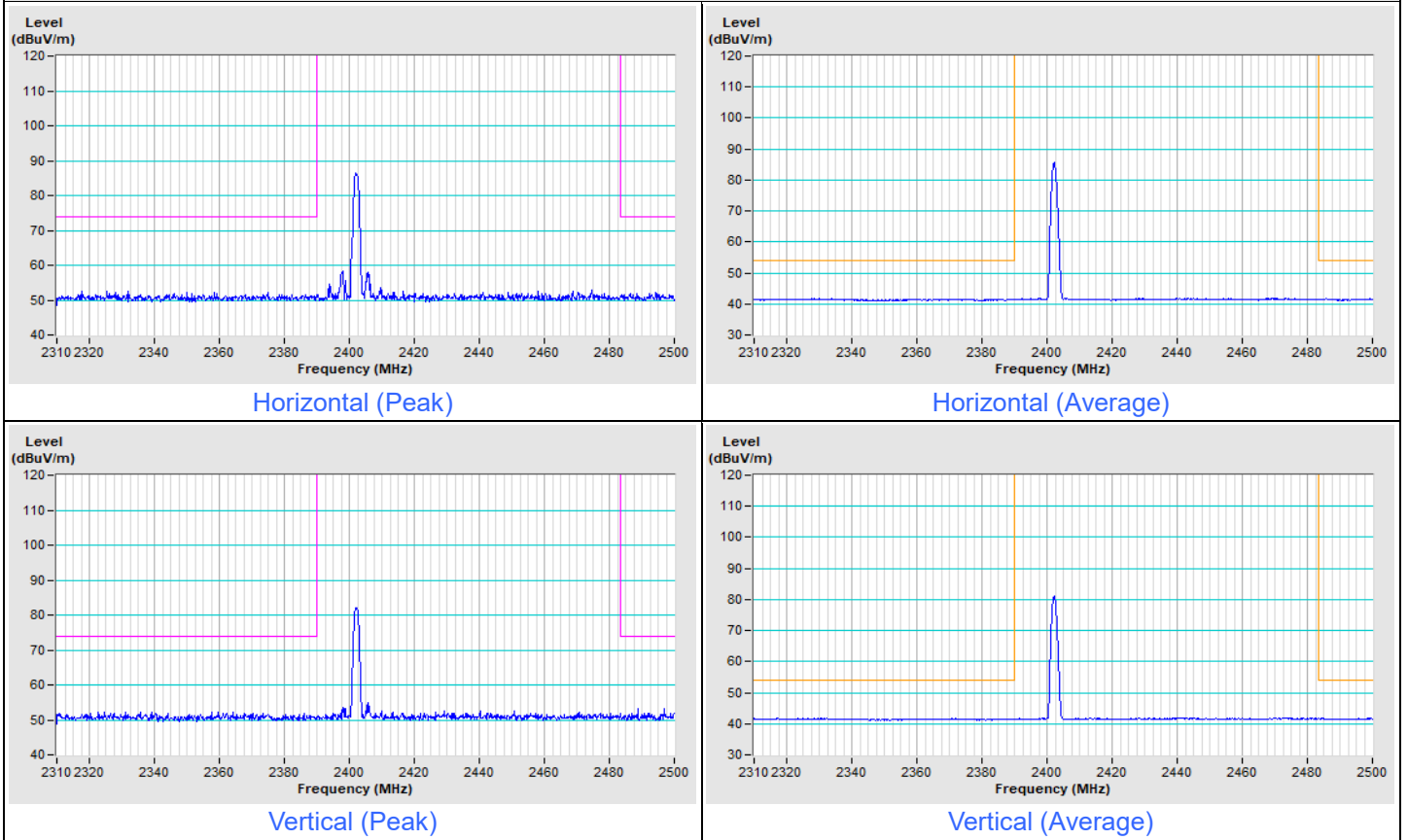

BT-LE 125K Channel 39

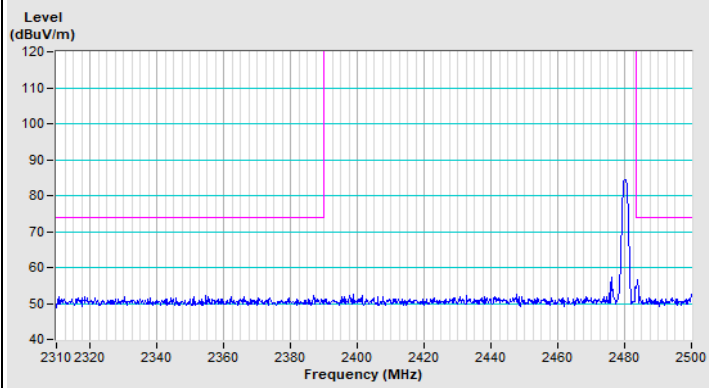

Horizontal (Peak)

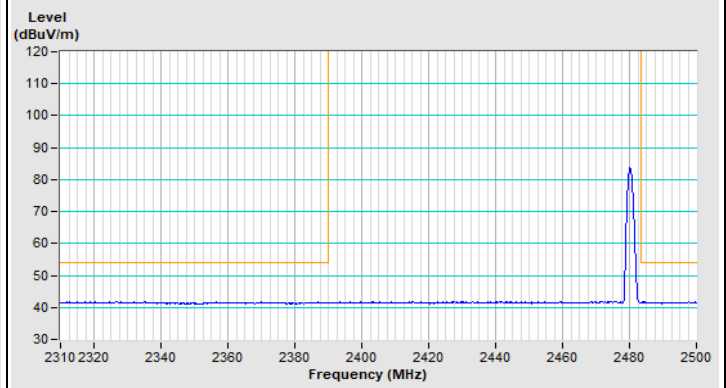

Horizontal (Average)

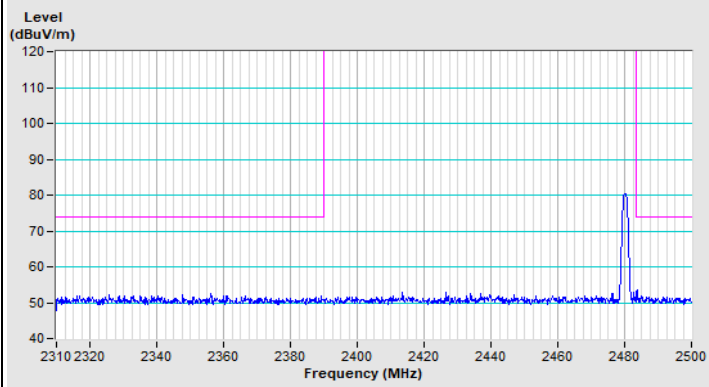

Vertical (Peak)

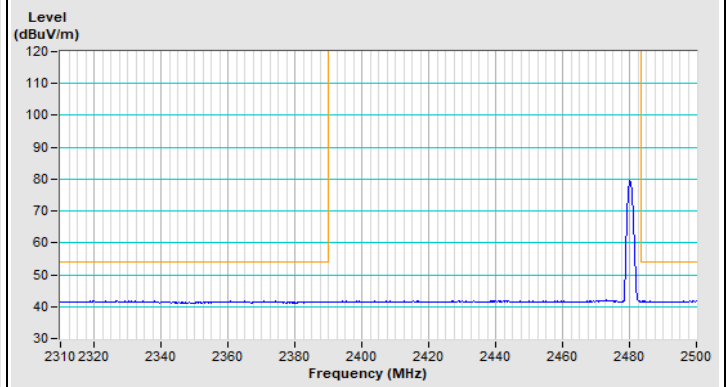

Vertical (Average)

| | | | |
|-----------------|--------------------|-------------------------------|----------------------------------------------------------------------|
| Frequency Range | 2.31 GHz ~ 2.5 GHz | Detector Function & Bandwidth | PK: RB=1 MHz, VB=3 MHz, DET=Peak AV: RB=1 MHz, VB=1 kHz, DET=Peak |
|-----------------|--------------------|-------------------------------|----------------------------------------------------------------------|

BT-LE 500K Channel 0

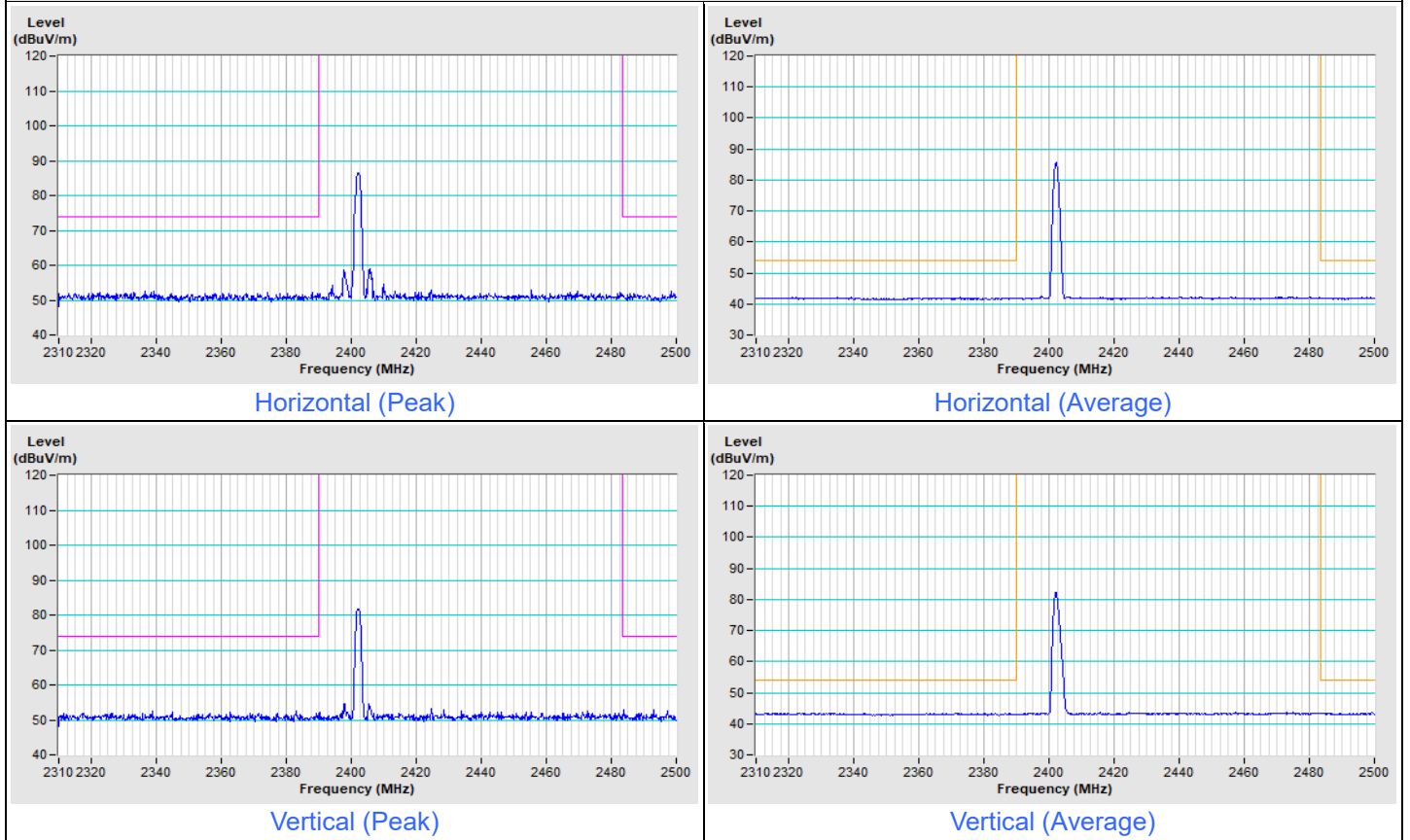

BT-LE 500K Channel 39

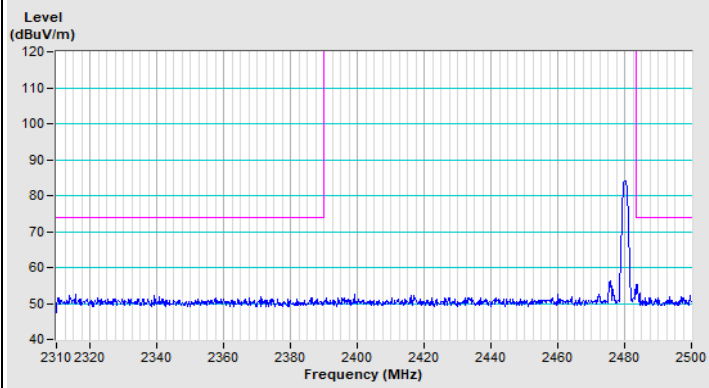

Horizontal (Peak)

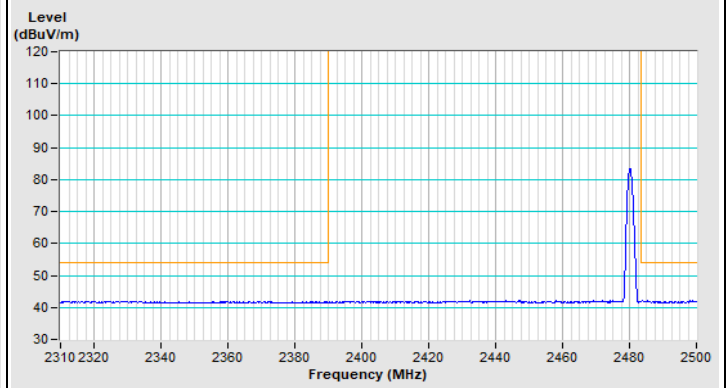

Horizontal (Average)

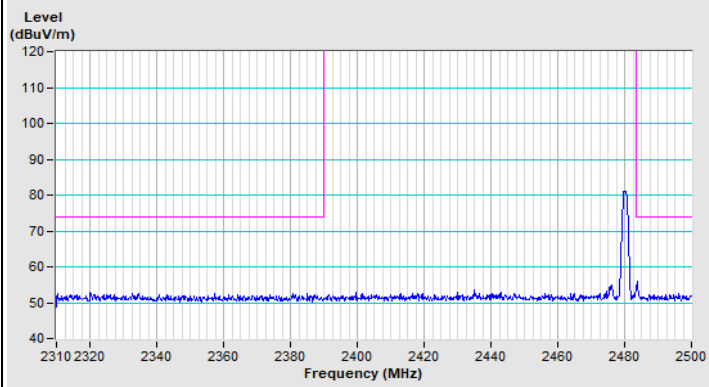

Vertical (Peak)

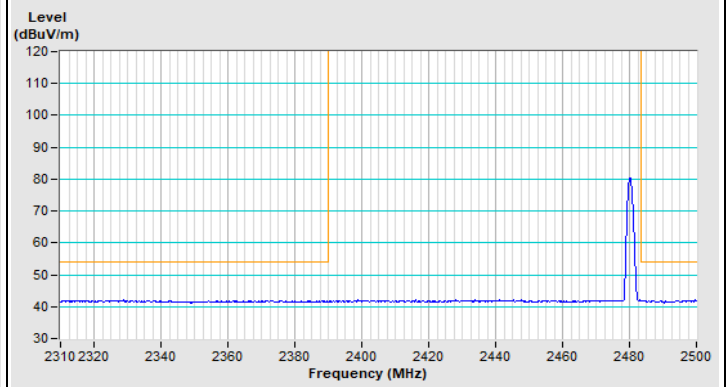

Vertical (Average)

8 Pictures of Test Arrangements

Please refer to the attached file (Test Setup Photo)

9 Information of the Testing Laboratories

We, Bureau Veritas Consumer Products Services (H.K.) Ltd., Taoyuan Branch, were founded in 1988 to provide our best service in EMC, Radio, Telecom and Safety consultation. Our laboratories are FCC recognized accredited test firms and accredited according to ISO/IEC 17025.

If you have any comments, please feel free to contact us at the following:

Lin Kou EMC/RF Lab

Tel: 886-2-26052180

Fax: 886-2-26051924

Hsin Chu EMC/RF/Telecom Lab

Tel: 886-3-6668565

Fax: 886-3-6668323

Hwa Ya EMC/RF/Safety Lab

Tel: 886-3-3183232

Fax: 886-3-3270892

Email: service.adt@bureauveritas.com

Web Site: <http://ee.bureauveritas.com.tw>

The address and road map of all our labs can be found in our web site also.

--- END ---