

SPECIFICATION FOR APPROVAL

| | |
|-----------------------|---|
| 客 戶: CUSTOMER: | Kajet Technology International Corporation |
| 客 戶 料 號: CUST P/N: | A11单层发射L槽模組 501-00XQ-0008 |
| 泛 亞 料 號: FINE P/N: | 501-00XQ-0008 |
| 產 品 型 號: DESC: | Φ 20.5x43-10Ts-0.08x105-14mm-47C |
| 日 期: DATE: | 2018/01/31 |
| 版 本: Version: | A.0 |

| 擬制 PREPARED BY | 審核 CHECKED BY | 批准 APPROVED BY | 客戶承認 CUSTOMER APPROVE |
|-------------------|------------------|-------------------|--------------------------|
| 郭洋洋 | 蔡紀雨 | 倪星 | |

| | | | | |
|---------------|---------------------------------|----------|----------------|-----|
| 產品型號: DESC | Φ20.5x43-10Ts-0.08x105-14mm-47C | 版本 | 客戶 CUST: | 562 |
| | | Rev: A.0 | 客戶料号 CUST P/N: | |

一、尺寸 DIMENSION:(mm)

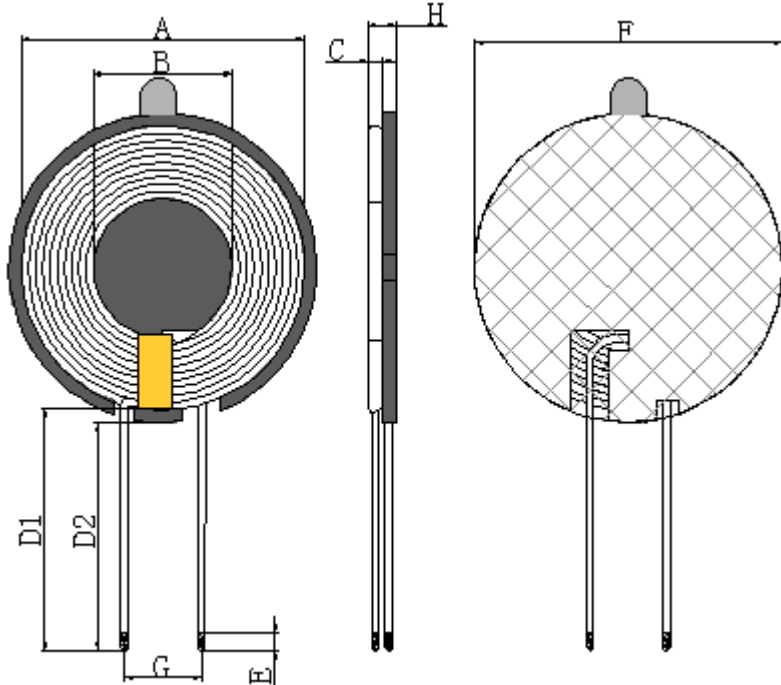

| | |
|----|-----------------|
| A | 43.0±1.0 |
| B | 20.5±0.5 |
| C | 1.3 Max |
| D1 | 14±1 |
| D2 | 12.5 ref |
| E | 3-5 |
| F | 47±1 |
| G | 9.0 ref |
| H | 2.5 Max (不含离型纸) |
| | |
| | |

注:

- 线圈需贴磁片,磁片外直径47mm,有L型线双槽,厚度 1.0mm;
Coil needs to be attached to the magnetic strip, and the outer diameter of the magnetic disc is 47mm, with the l-shaped line double-groove and the thickness is 1.0mm;
- 磁片正面黑色 PET 膜,背面贴带手撕位圆形直径46.5mm(ref), 双面胶带白色离型纸。
Black PET film on the front of the magnetic film, with a circular diameter of 46.5mm(ref) on the back and white paper of double-sided tape.
- 出线位置缠 8mm±0.5 宽度高温胶纸1-2Ts;
Position of the outgoing line is 8mm + 0.5mm, and the high-temperature adhesive paper is 1-2ts;
- 线圈贴磁片用白色硅胶固定;
Coil tape is fixed with white silica gel;

二、原理图 SCHEMATIC DIAGRAM:

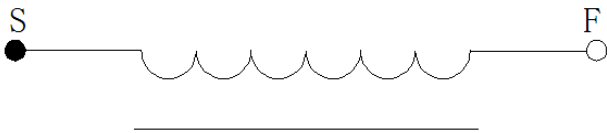

三、绕线参数 Winding Specification:

| 序号 NO. | 端子 TERMINAL | | 线径 WIRE | 圈数 Turns | 绕线方向 Winding Direction |
|-----------|----------------|---|---------------|-------------|---------------------------|
| 1 | S | F | 丝包线 0.08*105P | 10Ts | CCW |

四、电气特性 ELECTRICAL CHARACTERISTICS:

温度 TEMPERATURE:25±10°C, 湿度 RELATIVE HUMIDITY:65±20%

| 序号 NO. | 项目 ITEM | 端子 TERMINAL | 标准 SPECIFICATION | 测试条件 TEST FREQUENCY | 测试仪器 TEST EQUIPMENTS |
|-----------|------------|----------------|---------------------|------------------------|-------------------------|
| 1 | IND. | S-F | 3.8 uH±10% 单独线圈 | 100KHz/1.0V | LCZ METER 1062B |
| 2 | IND. | S-F | 6.3 uH±10% 加磁片 | 100KHz/1.0V | LCZ METER 1062B |
| 3 | DCR | S-F | | | |

| | |
|------------------------|-----------------------|
| 编制/日期 PREPARED BY/DATE | 审核/日期 CHECKED BY/DATE |
| 郭洋洋 2018/01/31 | 蔡纪雨 2018/01/31 |