

TEST REPORT

Report No.: 19120923HKG-001

C&A Marketing Inc.

Application For Certification
(Original Grant)

FCC ID: 2AD2W-LOWS510BO

915MHz Transmitter

Prepared and Checked by:

Approved by:

Signed On File
Wong Cheuk Ho, Herbert
Lead Engineer

Wong Kwok Yeung, Kenneth
Senior Lead Engineer
Date: January 08, 2020

TEST REPORT

GENERAL INFORMATION

Grantee:	C&A Marketing Inc.
Grantee Address:	114 Tived Lane East, Edison New Jersey 08837 United States
Contact Person:	Chaim Piekarski
Tel:	848-244-2000
Fax:	848-244-2361
e-mail:	legal@caglobal.com
Manufacturer:	CCL Electronics Ltd.
Manufacturer Address:	Unit 1-3, 9/F., Wang Lung Industrial Building, 11 Lung Tak Street, Tsuen Wan, N.T., Hong Kong.
Brand Name:	Logia
Model:	LOWS510B
Type of EUT:	Transmitter
Description of EUT:	Wireless Weather Sensor (915MHz Transmitter)
Serial Number:	N/A
FCC ID:	2AD2W-LOWS510BO
Date of Sample Submitted:	December 30, 2019
Date of Test:	December 30, 2019 to January 08, 2020
Report No.:	19120923HKG-001
Report Date:	January 08, 2020
Environmental Conditions:	Temperature: +10 to 40°C Humidity: 10 to 90%
Conclusion:	Test was conducted by client submitted sample. The submitted sample as received complied with the 47 CFR Part 15 Certification.

TEST REPORT

SUMMARY OF TEST RESULT

Test Specification	Reference	Results
Radiated Emission	15.249, 15.209	Pass
Radiated Emission on the Bandedge		
Radiated Emission in Restricted Bands	15.205	Pass

The equipment under test is found to be complying with the following standards:
FCC Part 15, October 1, 2018 Edition

- Note:
1. The EUT uses a permanently attached antenna which, in accordance to section 15.203, is considered sufficient to comply with the provisions of this section.
 2. Pursuant to FCC part 15 Section 15.215(c), the 20 dB bandwidth of the emission was contained within the frequency band designated (mentioned as above) which the EUT operated. The effects, if any, from frequency sweeping, frequency hopping, other modulation techniques and frequency stability over excepted variations in temperature and supply voltage were considered.

TEST REPORT

TABLE OF CONTENTS

1.0 GENERAL DESCRIPTION 5

 1.1 Product Description5

 1.2 Related Submittal(s) Grants5

 1.3 Test Methodology.....5

 1.4 Test Facility5

2.0 SYSTEM TEST CONFIGURATION..... 6

 2.1 Justification.....6

 2.2 EUT Exercising Software.....6

 2.3 Special Accessories6

 2.4 Measurement Uncertainty.....6

 2.5 Support Equipment List and Description.....6

3.0 EMISSION RESULTS..... 7

 3.1 Field Strength Calculation7

 3.2 Radiated Emission Configuration Photograph.....8

 3.3 Radiated Emission Data8

4.0 EQUIPMENT PHOTOGRAPHS 11

5.0 PRODUCT LABELLING..... 11

6.0 TECHNICAL SPECIFICATIONS 11

7.0 INSTRUCTION MANUAL..... 11

8.0 MISCELLANEOUS INFORMATION 12

 8.1 Radiated Emission on the Bandedge.....12

 8.2 Discussion of Pulse Desensitization.....13

 8.3 Calculation of Average Factor13

 8.4 Emissions Test Procedures.....13

9.0 CONFIDENTIALITY REQUEST 16

10.0 EQUIPMENT LIST 16

TEST REPORT

1.0 GENERAL DESCRIPTION

1.1 Product Description

The equipment under test (EUT) is the Wireless Weather Sensor (915MHz Transmitter) of the 5-in-1 Wireless Weather Sensor with Wifi. The EUT is powered by 4.5VDC (3X 1.5V "AA" batteries). The EUT will transmit RF signal to the corresponding receiver and the receiver will display the humidity and temperature on the screen of the receiver.

Antenna Type: Internal, Integral

For electronic filing, the brief circuit description is saved with filename: descri.pdf.

1.2 Related Submittal(s) Grants

This is a single application for certification of a transceiver.

1.3 Test Methodology

Radiated emission measurements were performed according to the procedures in ANSI C63.10 (2013). All radiated measurements were performed in an 3m Chamber. Preliminary scans were performed in the 3m Chamber only to determine worst case modes. All radiated tests were performed at an antenna to EUT distance of 3 meters, unless stated otherwise in the “**Justification Section**” of this Application.

1.4 Test Facility

The 3m Chamber facility used to collect the radiated data is located at Workshop No. 3, G/F., World-Wide Industrial Centre, 43-47 Shan Mei Street, Fo Tan, Sha Tin, N.T., Hong Kong. This test facility and site measurement data have been placed on file with the FCC.

TEST REPORT

2.0 SYSTEM TEST CONFIGURATION

2.1 Justification

The system was configured for testing in a typical fashion (as a customer would normally use it), and in the confines as outlined in ANSI C63.10 (2013).

The device was powered by new 4.5VDC (3 x 1.5V AA batteries).

For maximizing emissions, the EUT was rotated through 360°, the antenna height was varied from 1 meter to 4 meters above the ground plane, and the antenna polarization was changed. This step by step procedure for maximizing emissions led to the data reported in Exhibit 3.0.

The unit was operated standalone and placed in the center of the turntable.

The equipment under test (EUT) was configured for testing in a typical fashion (as a customer would normally use it). The EUT was mounted to a plastic stand if necessary and placed on the wooden turntable, which enabled the engineer to maximize emissions through its placement in the three orthogonal axes.

2.2 EUT Exercising Software

The EUT exercise program (if any) used during radiated and conducted testing was designed to exercise the various system components in a manner similar to a typical use.

2.3 Special Accessories

There are no special accessories necessary for compliance of this product.

2.4 Measurement Uncertainty

When determining of the test conclusion, the Measurement Uncertainty of test has been considered.

Uncertainty and Compliance - Unless the standard specifically states that measured values are to be extended by the measurement uncertainty in determining compliance, all compliance determinations are based on the actual measured value.

2.5 Support Equipment List and Description

N/A.

TEST REPORT

3.0 EMISSION RESULTS

Data is included of the worst case configuration (the configuration which resulted in the highest emission levels). A sample calculation, configuration photographs and data tables of the emissions are included.

3.1 Field Strength Calculation

The field strength is calculated by adding the Antenna Factor and Cable Factor, and subtracting the Amplifier Gain (if any), Average Factor (optional) from the measured reading. The basic equation with a sample calculation is as follows:

$$FS = RA + AF + CF - AG - AV$$

where FS = Field Strength in dB μ V/m

RA = Receiver Amplitude (including preamplifier) in dB μ V

CF = Cable Attenuation Factor in dB

AF = Antenna Factor in dB

AG = Amplifier Gain in dB

AV = Average Factor in dB

In the following table(s), the reading shown on the data table reflects the preamplifier gain. An example for the calculations in the following table is as follows:

$$FS = RR + LF$$

where FS = Field Strength in dB μ V/m

RR = RA - AG - AV in dB μ V

LF = CF + AF in dB

Assume a receiver reading of 52.0 dB μ V is obtained. The antenna factor of 7.4 dB and cable factor of 1.6 dB are added. The amplifier gain of 29 dB and average factor of 5 dB are subtracted, giving a field strength of 32 dB μ V/m. This value in dB μ V/m was converted to its corresponding level in μ V/m.

$$RA = 52.0 \text{ dB}\mu\text{V/m}$$

$$AF = 7.4 \text{ dB}$$

$$CF = 1.6 \text{ dB}$$

$$AG = 29.0 \text{ dB}$$

$$AV = 5.0 \text{ dB}$$

$$FS = RR + LF$$

$$FS = 18 + 9 = 27 \text{ dB}\mu\text{V/m}$$

$$RR = 18.0 \text{ dB}\mu\text{V}$$

$$LF = 9.0 \text{ dB}$$

$$\text{Level in } \mu\text{V/m} = \text{Common Antilogarithm } [(27 \text{ dB}\mu\text{V/m})/20] = 22.4 \mu\text{V/m}$$

TEST REPORT

3.2 Radiated Emission Configuration Photograph

The worst case in radiated emission was found at 928.000 MHz

For electronic filing, the worst case radiated emission configuration photographs are saved with filename: radiated photos.pdf.

3.3 Radiated Emission Data

The data on the following page lists the significant emission frequencies, the limit and the margin of compliance. Numbers with a minus sign are below the limit.

Judgment: Passed by 5.6 dB

TEST REPORT

RADIATED EMISSIONS

Model: LOWS510B

Date of Test: January 08, 2020

Worst-Case Operating Mode: Transmitting

Table 1
Pursuant to FCC Part 15 Section 15.249 Requirement

Polarization	Frequency (MHz)	Reading (dBμV)	Pre-Amp Gain (dB)	Antenna Factor (dB)	Net at 3m - Average (dBμV/m)	Average Limit at 3m (dBμV/m)	Margin (dB)
V	1830.000	49.8	33	27.2	44.0	54.0	-10.0
V	2745.000	43.4	33	30.4	40.8	54.0	-13.2
H	3660.000	41.9	33	33.3	42.2	54.0	-11.8
H	4575.000	40.6	33	34.9	42.5	54.0	-11.5
V	5490.000	40.5	33	35.7	43.2	54.0	-10.8
V	6405.000	39.7	33	36.9	43.6	54.0	-10.4
H	7320.000	38.9	33	37.9	43.8	54.0	-10.2
V	8235.000	38.2	33	39.0	44.2	54.0	-9.8
V	9150.000	40.8	33	40.4	48.2	54.0	-5.8

Polarization	Frequency (MHz)	Reading (dBμV)	Pre-Amp Gain (dB)	Antenna Factor (dB)	Net at 3m - Peak (dBμV/m)	Peak Limit at 3m (dBμV/m)	Margin (dB)
V	1830.000	59.6	33	27.2	53.8	74.0	-20.2
V	2745.000	46.6	33	30.4	44.0	74.0	-30.0
H	3660.000	43.9	33	33.3	44.2	74.0	-29.8
H	4575.000	41.6	33	34.9	43.5	74.0	-30.5
V	5490.000	43.5	33	35.7	46.2	74.0	-27.8
V	6405.000	42.5	33	36.9	46.4	74.0	-27.6
H	7320.000	41.7	33	37.9	46.6	74.0	-27.4
V	8235.000	40.8	33	39.0	46.8	74.0	-27.2
V	9150.000	44.8	33	40.4	52.2	74.0	-21.8

- NOTES:
1. Peak Detector Data unless otherwise stated. Average measurement is according to C63.10 (2013).
 2. All measurements were made at 3 meters. Harmonic emissions not detected at the 3-meter distances were measured at 0.3-meter and an inverse proportional extrapolation was performed to compare the signal level to the 3-meter limit. No other harmonic emissions than those reported were detected at a test distance of 0.3-meter.
 3. Negative sign in the column shows value below limit.
 4. Horn antenna is used for the emission over 1000MHz.
 5. Emission (the row indicated by **bold italic**) within the restricted band meets the requirement of FCC Part 15 Section 15.205.
 6. Measurement Uncertainty is ±5.3dB at a level of confidence of 95%.

TEST REPORT

Model: LOWS510B

Date of Test: January 08, 2020

Worst-Case Operating Mode: Transmitting

Table 2
Pursuant to FCC Part 15 Section 15.209 Requirement

Polarization	Frequency (MHz)	Reading (dBµV)	Pre-amp (dB)	Antenna Factor (dB)	Net at 3m (dBµV/m)	Limit at 3m (dBµV/m)	Margin (dB)
V	39.746	18.4	16	10.0	12.4	40.0	-27.6
V	119.088	11.8	16	14.0	9.8	43.5	-33.7
V	138.100	13.2	16	14.0	11.2	43.5	-32.3
V	224.022	4.5	16	18.0	6.5	46.0	-39.5
V	344.434	3.6	16	24.0	11.6	46.0	-34.4
V	431.818	5.7	16	25.0	14.7	46.0	-31.3
V	902.000	24.2	16	32.0	40.2	46.0	-5.8
V	915.000	67.0	16	33.0	84.0	94.0	-10.0
V	928.000	23.4	16	33.0	40.4	46.0	-5.6

- NOTES:
1. Quasi-Peak Detector Data unless otherwise stated.
 2. All measurements were made at 3 meters. Harmonic emissions not detected at the 3-meter distances were measured at 0.3-meter and an inverse proportional extrapolation was performed to compare the signal level to the 3-meter limit. No other harmonic emissions than those reported were detected at a test distance of 0.3-meter.
 3. Negative sign in the column shows value below limit.
 4. Horn antenna is used for the emission over 1000MHz.
 5. Emission (the row indicated by **bold italic**) within the restricted band meets the requirement of FCC Part 15 Section 15.205.
 6. Measurement Uncertainty is ±5.3dB at a level of confidence of 95%.

TEST REPORT

4.0 EQUIPMENT PHOTOGRAPHS

For electronic filing, the photographs are saved with filename: external photos.pdf and internal photos.pdf.

5.0 PRODUCT LABELLING

For electronics filing, the FCC ID label artwork and the label location are saved with filename: label.pdf.

6.0 TECHNICAL SPECIFICATIONS

For electronic filing, the block diagram and schematic of the tested EUT are saved with filename: block.pdf and circuit.pdf respectively.

7.0 INSTRUCTION MANUAL

For electronic filing, a preliminary copy of the Instruction Manual is saved with filename: manual.pdf.

This manual will be provided to the end-user with each unit sold/leased in the United States.

TEST REPORT

8.0 MISCELLANEOUS INFORMATION

The miscellaneous information includes details of the test procedure and measured bandwidth / calculation of factor such as pulse desensitization and averaging factor (calculation and timing diagram).

8.1 Radiated Emission on the Bandedge

The bandedge data is shown in frequency table 2.

TEST REPORT

8.2 Discussion of Pulse Desensitization

Pulse desensitivity is not applicable for this device. Since the transmitter transmits the RF signal continuously.

8.3 Calculation of Average Factor

N/A.

8.4 Emissions Test Procedures

The following is a description of the test procedure used by Intertek Testing Services Hong Kong Ltd. in the measurements of transmitter operating under the Part 15, Subpart C rules.

The transmitting equipment under test (EUT) is placed on a wooden turntable which is four feet in diameter and approximately 0.8m in height above the ground plane for emission measurement at or below 1GHz and 1.5m in height above the ground plane for emission measurement above 1GHz. During the radiated emissions test, the turntable is rotated and any cables leaving the EUT are manipulated to find the configuration resulting in maximum emissions. The EUT is adjusted through all three orthogonal axis to obtain maximum emission levels. The antenna height and polarization are also varied during the testing to search for maximum signal levels. The height of the antenna is varied from one to four meters.

Detector function for radiated emissions is in peak mode. Average readings, when required, are taken by measuring the duty cycle of the equipment under test and subtracting the corresponding amount in dB from the measured peak readings. A detailed description for the calculation of the average factor can be found in Exhibit 8.3.

The frequency range scanned is from the lowest radio frequency signal generated in the device which is greater than 9 kHz to the tenth harmonic of the highest fundamental frequency or 40 GHz, whichever is lower.

TEST REPORT

8.4 Emissions Test Procedures (cont'd)

The EUT is warmed up for 15 minutes prior to the test.

AC power to the unit is varied from 85% to 115% nominal and variation in the fundamental emission field strength is recorded. If battery powered, a new, fully charged battery is used.

Conducted measurements were made as described in ANSI C63.10 (2013).

The IF bandwidth used for measurement of radiated signal strength was 100 kHz or greater when frequency is below 1000 MHz. Where pulsed transmissions of short enough pulse duration warrant, a greater bandwidth is selected according to the recommendations of Hewlett Packard Application Note 150-2. A discussion of whether pulse desensitivity is applicable to this unit is included in this report (See Exhibit 8.1). Above 1000 MHz, a resolution bandwidth of 3 MHz is used.

Transmitter measurements are normally conducted at a measurement distance of three meters. However, to assure low enough noise floor in the forbidden bands and above 1 GHz, signals are acquired at a distance of one meter or less. All measurements are extrapolated to three meters using inverse scaling, unless otherwise reported. Measurements taken at a closer distance are so marked.

TEST REPORT

8.4.1 Radiated Emission Test Setup

The figure below shows the test setup, which is utilized to make these measurements.

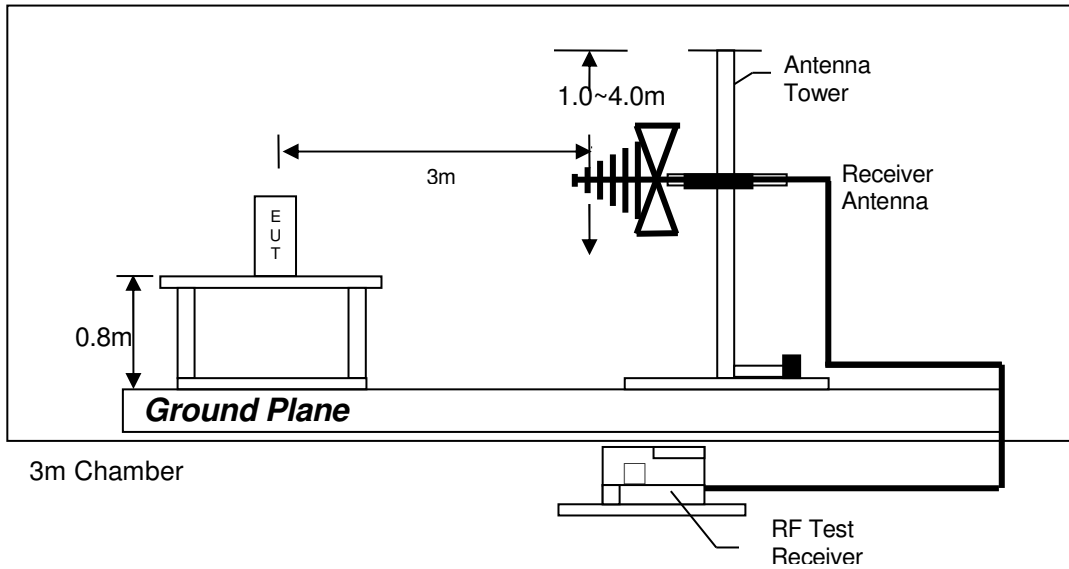

Test setup of radiated emissions up to 1GHz

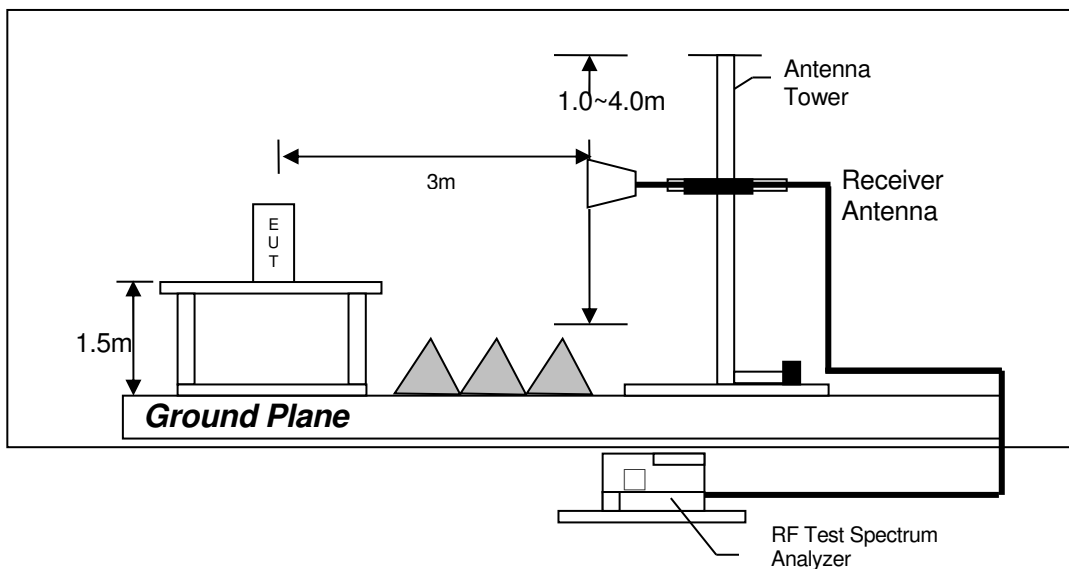

Test setup of radiated emissions above 1GHz

TEST REPORT

9.0 CONFIDENTIALITY REQUEST

For electronic filing, a preliminary copy of the confidentiality request is saved with filename: request.pdf.

10.0 EQUIPMENT LIST

1) Radiated Emissions Test

Equipment	EMI Test Receiver	Spectrum Analyzer	Biconical Antenna
Registration No.	EW-3156	EW-2249	EW-0571
Manufacturer	R&S	ROHDESCHWARZ	EMCO
Model No.	ESR26	FSP30	3104C
Calibration Date	August 01, 2019	May 16, 2019	July 23, 2019
Calibration Due Date	August 01, 2020	May 16, 2020	July 23, 2021

Equipment	Log Periodic Antenna	Double Ridged Guide Antenna	14m Double Shield RF Cable (20MHz - 6GHz)
Registration No.	EW-0447	EW-1133	EW-2074
Manufacturer	EMCO	EMCO	RADIALL
Model No.	3146	3115	Nm-RG142-
Calibration Date	September 25, 2019	November 29, 2018	March 31, 2019
Calibration Due Date	March 25, 2021	May 29, 2020	March 31, 2020

Equipment	15m 40GHz indoor RF Cable	RF Pre-amplifier (9kHz to 6000MHz)	Solid State Low Noise Pre-amplifier Assembly (1 - 18)GHz
Registration No.	EW-3032	EW-3424	EW-3229
Manufacturer	GREATBILLION	SCHWARZBECK	BONN ELEKTRO
Model No.	SMA(m) St-SMA (m) St, 15m long	BBV9744	BLMA 0118-5G
Calibration Date	May 14, 2019	July 23, 2019	June 28, 2019
Calibration Due Date	May 14, 2020	July 23, 2020	June 28, 2020

Equipment	Pyramidal Horn Antenna	Active Loop H-field (9kHz to 30MHz)
Registration No.	EW-0905	EW-3326
Manufacturer	EMCO	EMCO
Model No.	3160-09	6502
Calibration Date	July 23, 2019	March 21, 2019
Calibration Due Date	January 23, 2021	September 21, 2020

END OF TEST REPORT