

APPENDIX 2: SAR Measurement data

Appendix 2-1: Worst Reported SAR(1g) Plot

Plot 2-1: (Repeated) Front-right(1) & touch / 11b (2Mbps) / 2462MHz (*. Highest reported SAR(1g) condition)

EUT: Digital Camera; Type: R05010; Serial: 0000061

Mode: 11b(2Mbps, DQPSK/DSSS) (UID: 0, Wi-fi_2.4GHz(0), Frame Length in ms: 0, PAR: 0, PMF: 1); Frequency: 2462 MHz; Crest Factor: 1.0

Medium: HSL2450(2102); Medium parameters used: f = 2462 MHz; $\sigma = 1.896$ S/m; $\epsilon_r = 37.63$; $\rho = 1000$ kg/m³

Measurement Standard: DASYS (IEEE/IEC/ANSI C63.19-2007)

DASY Configuration: -Electronics: DAE4 Sn626; Calibrated: 2020/11/17 / -Phantom: ELI v4.0; Type: QDOVA001BA; Serial: 1059; Phantom section: Flat Section

-DASY52.52.10.3(1513); SEMCAD X 14.6.13(7474) / -Probe: EX3DV4 - SN3907; ConvF(7.26, 7.26, 7.26) @ 2462 MHz; Calibrated: 2020/04/27

-Sensor-Surface: 2mm (Mechanical Surface Detection), z = 1.0, 31.0, 161.0

touch,h24,2/oo24h41(re12);2462,Frt-R(1)&d0,b(2m)/

Area:72x60,12 (7x6x1): Measurement grid: dx=12mm, dy=12mm; Maximum value of SAR (measured) = 1.05 W/kg

Area:72x60,12 (61x51x1): Interpolated grid: dx=1.200 mm, dy=1.200 mm; Maximum value of SAR (interpolated) = 1.66 W/kg

Z;160,5 (1x1x33): Measurement grid: dx=20mm, dy=20mm, dz=5mm; Maximum value of SAR (measured) = 1.79 W/kg

Zoom:30x30x30,5 (7x7x7)/Cube 0: Measurement grid: dx=5mm, dy=5mm, dz=5mm;

Reference Value = 30.20 V/m; Power Drift = 0.20 dB; Maximum value of SAR (measured) = 1.83 W/kg; Peak SAR (extrapolated) = 2.79 W/kg

SAR(1 g) = 1.01 W/kg; SAR(10 g) = 0.372 W/kg (*. Smallest distance from peaks to all points 3 dB below = 6 mm; Ratio of SAR at M2 to SAR at M1 = 37.7%)

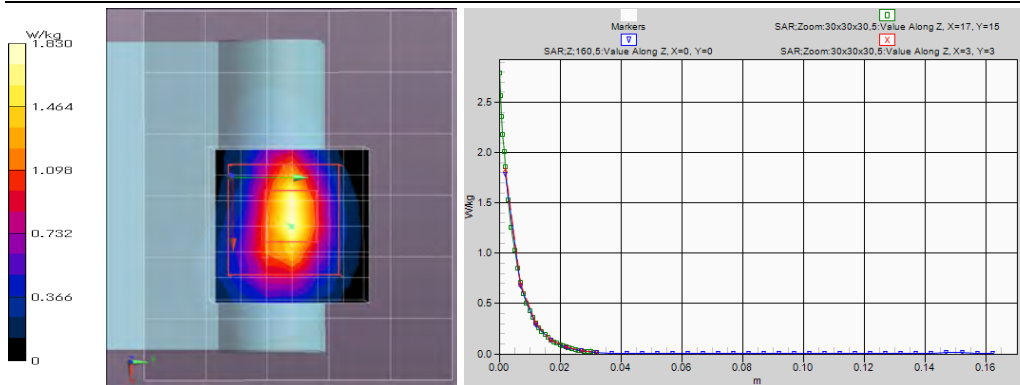

Remarks: *. Date tested: 2021/2/25; Tested by: Hiroshi Naka; Tested place: No.7 shielded room,
 *. liquid depth: 150 mm; Position: distance of EUT to phantom: 0 mm (2 mm to liquid); ambient: (24~25) deg.C. / (35~50) %RH,
 *. liquid temperature: 23.6(start)/23.6(end)/23.7(in check) deg.C. *. White cubic: zoom scan area, Red cubic: big=SAR(10g) /small=SAR(1g)

Appendix 2: SAR measurement data (cont'd)

Appendix 2-2: Repeat test (SAR measurement variability); SAR(1g) Plot

Plot 2-2: (Repeated) Front-right(1) & touch / 11g (6Mbps) / 2462MHz (*. Highest measured SAR(1g) condition)

EUT: Digital Camera; Type: R05010; Serial: 0000061

Mode: 11g(6Mbps, BPSK/OFDM) (UID: 0, Wi-fi_2.4GHz (0), Frame Length in ms: 0, PAR: 0, PMF: 1); **Frequency: 2462 MHz; Crest Factor: 1.0**

Medium: HSL2450(2102); Medium parameters used: f = 2462 MHz; $\sigma = 1.896$ S/m; $\epsilon_r = 37.63$; $\rho = 1000$ kg/m³

Measurement Standard: DASY5 (IEEE/IEC/ANSI C63.19-2007)

DASY Configuration: -Electronics: DAE4 Sn626; Calibrated: 2020/11/17 / -Phantom: ELI v4.0; Type: QDOVA001BA; Serial: 1059; Phantom section: Flat Section

-DASY52 52.10.3(1513); SEMCAD X 14.6.13(7474) / -Probe: EX3DV4 - SN3907; ConvF(7.26, 7.26, 7.26) @ 2462 MHz; Calibrated: 2020/04/27

-Sensor-Surface: 2mm (Mechanical Surface Detection), z = 1.0, 31.0

touch,h24,2/24h42(re10);2462,Frt-R(1)&d0,g(6m)/

Area:72x60,12 (7x6x1): Measurement grid: dx=12mm, dy=12mm; Maximum value of SAR (measured) = 1.26 W/kg

Area:72x60,12 (61x51x1): Interpolated grid: dx=1.200 mm, dy=1.200 mm; Maximum value of SAR (interpolated) = 1.94 W/kg

Zoom:30x30x30,5 (7x7x7)/Cube 0: Measurement grid: dx=5mm, dy=5mm, dz=5mm;

Reference Value = 33.07 V/m; Power Drift = -0.05 dB; Maximum value of SAR (measured) = 2.00 W/kg; Peak SAR (extrapolated) = 3.11 W/kg

SAR(1 g) = 1.12 W/kg; SAR(10 g) = 0.412 W/kg (*. Smallest distance from peaks to all points 3 dB below = 6 mm; Ratio of SAR at M2 to SAR at M1 = 38%)

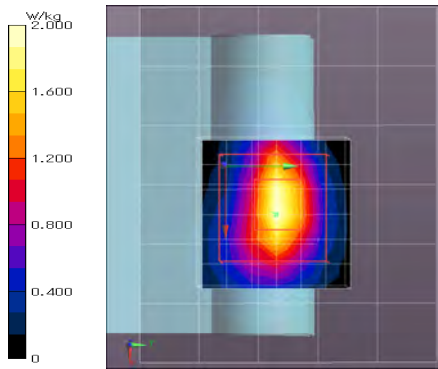

Remarks: *. Date tested: 2021/2/25; Tested by: Hiroshi Naka; Tested place: No.7 shielded room,
*. liquid depth: 150 mm; Position: distance of EUT to phantom: 0 mm (2 mm to liquid); ambient: (24~25) deg.C. / (35~50) %RH,
*. liquid temperature: 23.6(start)/23.5(end)/23.7(in check) deg.C.; *. White cubic: zoom scan area, Red cubic: big=SAR(10g)/small=SAR(1g)

Appendix 2-3: Device holder perturbation verification test; SAR(1g) Plot

Plot 3-1: (No device holder) Front-right(1) & touch / 11b (2Mbps) / 2462MHz (*. Highest reported SAR(1g) condition)

EUT: Digital Camera; Type: R05010; Serial: 0000061

Mode: 11b(2Mbps, DQPSK/DSSS) (UID: 0, Wi-fi_2.4GHz (0), Frame Length in ms: 0, PAR: 0, PMF: 1); **Frequency: 2462 MHz; Crest Factor: 1.0**

Medium: HSL2450(2102); Medium parameters used: f = 2462 MHz; $\sigma = 1.896$ S/m; $\epsilon_r = 37.63$; $\rho = 1000$ kg/m³

Measurement Standard: DASY5 (IEEE/IEC/ANSI C63.19-2007)

DASY Configuration: -Electronics: DAE4 Sn626; Calibrated: 2020/11/17 / -Phantom: ELI v4.0; Type: QDOVA001BA; Serial: 1059; Phantom section: Flat Section

-DASY52 52.10.3(1513); SEMCAD X 14.6.13(7474) / -Probe: EX3DV4 - SN3907; ConvF(7.26, 7.26, 7.26) @ 2462 MHz; Calibrated: 2020/04/27

-Sensor-Surface: 2mm (Mechanical Surface Detection), z = 1.0, 31.0, 161.0

touch,h24,4/24h44(43re);2462,Frt-R(1)&d0,b(2m),no-DH/

Area:72x60,12 (7x6x1): Measurement grid: dx=12mm, dy=12mm; Maximum value of SAR (measured) = 1.08 W/kg

Area:72x60,12 (61x51x1): Interpolated grid: dx=1.200 mm, dy=1.200 mm; Maximum value of SAR (interpolated) = 1.68 W/kg

Z;160,5 (1x1x33): Measurement grid: dx=20mm, dy=20mm, dz=5mm; Maximum value of SAR (measured) = 1.78 W/kg

Zoom:30x30x30,5 (7x7x7)/Cube 0: Measurement grid: dx=5mm, dy=5mm, dz=5mm;

Reference Value = 31.13 V/m; Power Drift = 0.04 dB; Maximum value of SAR (measured) = 1.78 W/kg; Peak SAR (extrapolated) = 2.68 W/kg

SAR(1 g) = 0.967 W/kg; SAR(10 g) = 0.353 W/kg (*. Smallest distance from peaks to all points 3 dB below = 6 mm; Ratio of SAR at M2 to SAR at M1 = 37.5%)

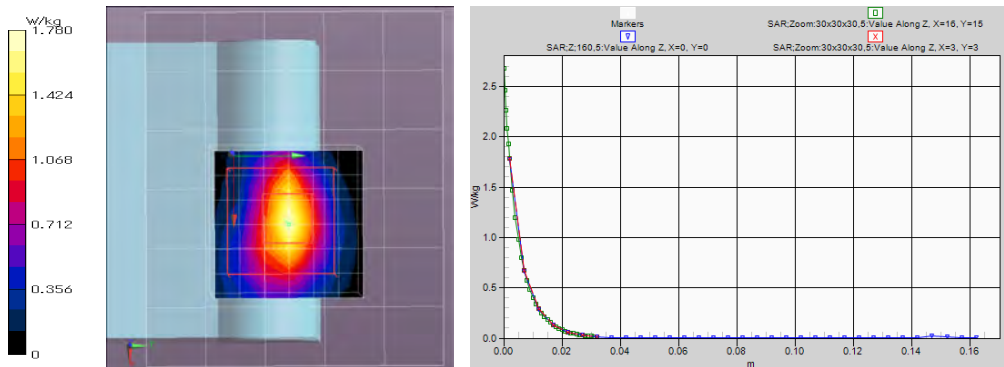

Remarks: *. Date tested: 2021/2/25; Tested by: Hiroshi Naka; Tested place: No.7 shielded room,
*. liquid depth: 150 mm; Position: distance of EUT to phantom: 0 mm (2 mm to liquid); ambient: (24~25) deg.C. / (35~50) %RH,
*. liquid temperature: 23.3(start)/23.3(end)/23.7(in check) deg.C.; *. White cubic: zoom scan area, Red cubic: big=SAR(10g)/small=SAR(1g)

Appendix 2: SAR measurement data (cont'd)

Appendix 2-4: Other SAR(1g) Plots

Plot 1-1: Front & touch / 11b (1Mbps) / 2437MHz

EUT: Digital Camera; Type: R05010; Serial: 0000061

Mode: 11b(1Mbps, DBPSK/DSSS) (UID: 0, Wi-fi_2.4GHz (0), Frame Length in ms: 0, PAR: 0, PMF: 1); **Frequency: 2437 MHz; Crest Factor: 1.0**
Medium: HSL2450(2102); Medium parameters used: f = 2437 MHz; $\sigma = 1.866$ S/m; $\epsilon_r = 37.71$; $\rho = 1000$ kg/m³

Measurement Standard: DASYS (IEEE/IEC/ANSI C63.19-2007)

DASY Configuration: -Electronics: DAE4 Sn626; Calibrated: 2020/11/17 / -Phantom: ELI v4.0; Type: QDOVA001BA; Serial: 1059; Phantom section: Flat Section
 -DASY52.52.10.3(1513); SEMCAD X 14.6.13(7474) / -Probe: EX3DV4 - SN3907; ConvF(7.26, 7.26, 7.26) @ 2437 MHz; Calibrated: 2020/04/27
 -Sensor-Surface: 2mm (Mechanical Surface Detection), z = 1.0, 31.0

touch,h24/24h1;2437,Front-lens&d0,b(1m/)

Area(all):72x132,12 (7x12x1): Measurement grid: dx=12mm, dy=12mm; Maximum value of SAR (measured) = 0.876 W/kg

Area(all):72x132,12 (61x111x1): Interpolated grid: dx=1.200 mm, dy=1.200 mm; Maximum value of SAR (interpolated) = 1.25 W/kg

Zoom:30x30x30,5 (7x7x7)/Cube 0: Measurement grid: dx=5mm, dy=5mm, dz=5mm;

Reference Value = 27.05 V/m; Power Drift = -0.15 dB; Maximum value of SAR (measured) = 1.29 W/kg; Peak SAR (extrapolated) = 1.87 W/kg

SAR(1 g) = 0.723 W/kg; SAR(10 g) = 0.275 W/kg (*. Smallest distance from peaks to all points 3 dB below = 6.1 mm; Ratio of SAR at M2 to SAR at M1 = 40.3%)

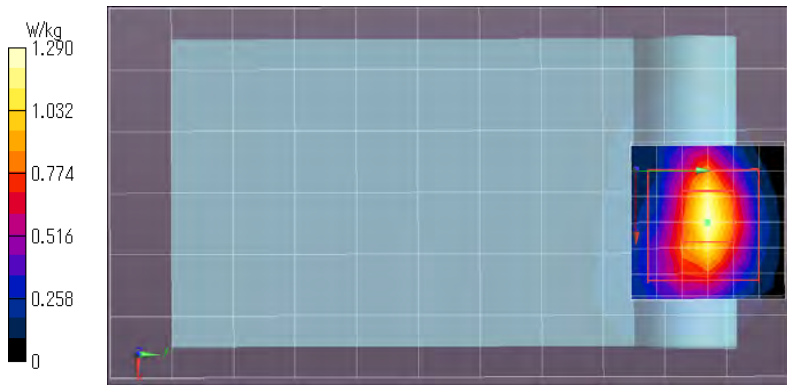

Remarks: * Date tested: 2021/2/24; Tested by: Hiroshi Naka; Tested place: No.7 shielded room,
 * liquid depth: 150 mm; Position: distance of EUT to phantom: 0 mm (2 mm to liquid); ambient: (24~25) deg.C. / (35~50) %RH,
 * liquid temperature: 23.3(start)/23.3(end)/23.7(in check) deg.C.; *.White cubic: zoom scan area, Red cubic: big=SAR(10g)/small=SAR(1g)

Plot 1-2: Front & touch / 11b (1Mbps) / 2462MHz

EUT: Digital Camera; Type: R05010; Serial: 0000061

Mode: 11b(1Mbps, DBPSK/DSSS) (UID: 0, Wi-fi_2.4GHz (0), Frame Length in ms: 0, PAR: 0, PMF: 1); **Frequency: 2462 MHz; Crest Factor: 1.0**
Medium: HSL2450(2102); Medium parameters used: f = 2462 MHz; $\sigma = 1.896$ S/m; $\epsilon_r = 37.63$; $\rho = 1000$ kg/m³

Measurement Standard: DASYS (IEEE/IEC/ANSI C63.19-2007)

DASY Configuration: -Electronics: DAE4 Sn626; Calibrated: 2020/11/17 / -Phantom: ELI v4.0; Type: QDOVA001BA; Serial: 1059; Phantom section: Flat Section
 -DASY52.52.10.3(1513); SEMCAD X 14.6.13(7474) / -Probe: EX3DV4 - SN3907; ConvF(7.26, 7.26, 7.26) @ 2462 MHz; Calibrated: 2020/04/27
 -Sensor-Surface: 2mm (Mechanical Surface Detection), z = 1.0, 31.0

touch,h24/24h3;2462,Front-lens&d0,b(1m/)

Area:72x60,12 (7x6x1): Measurement grid: dx=12mm, dy=12mm; Maximum value of SAR (measured) = 0.936 W/kg

Area:72x60,12 (61x51x1): Interpolated grid: dx=1.200 mm, dy=1.200 mm; Maximum value of SAR (interpolated) = 1.39 W/kg

Zoom:30x30x30,5 (7x7x7)/Cube 0: Measurement grid: dx=5mm, dy=5mm, dz=5mm;

Reference Value = 27.34 V/m; Power Drift = -0.07 dB; Maximum value of SAR (measured) = 1.37 W/kg; Peak SAR (extrapolated) = 2.03 W/kg

SAR(1 g) = 0.771 W/kg; SAR(10 g) = 0.292 W/kg (*. Smallest distance from peaks to all points 3 dB below = 6.1 mm; Ratio of SAR at M2 to SAR at M1 = 39.5%)

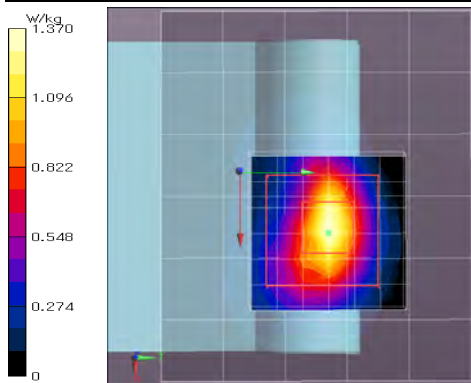

Remarks: * Date tested: 2021/2/24; Tested by: Hiroshi Naka; Tested place: No.7 shielded room,
 * liquid depth: 150 mm; Position: distance of EUT to phantom: 0 mm (2 mm to liquid); ambient: (24~25) deg.C. / (35~50) %RH,
 * liquid temperature: 23.3(start)/23.3(end)/23.7(in check) deg.C.; *.White cubic: zoom scan area, Red cubic: big=SAR(10g)/small=SAR(1g)

Appendix 2: SAR measurement data / Appendix 2-4: Other SAR(1g) Plots (cont'd)**Plot 1-3: Front & touch / 11b (1Mbps) / 2412MHz****EUT: Digital Camera; Type: R05010; Serial: 0000061****Mode: 11b(1Mbps, DBPSK/DSSS)** (UID: 0, Wi-fi_2.4GHz (0), Frame Length in ms: 0; PAR: 0; PMF: 1); **Frequency: 2412 MHz; Crest Factor: 1.0****Medium: HSL2450(2102); Medium parameters used: $f = 2412$ MHz; $\sigma = 1.837$ S/m; $\epsilon_r = 37.82$; $\rho = 1000$ kg/m³**

Measurement Standard: DASYS5 (IEEE/IEC/ANSI C63.19-2007)

DASY Configuration: -Electronics: DAE4 Sn626; Calibrated: 2020/11/17 / -Phantom: ELI v4.0; Type: QDOVA001BA; Serial: 1059; Phantom section: Flat Section

-DASY52 52.10.3(1513); SEMCAD X 14.6.13(7474) / -Probe: EX3DV4 - SN3907; ConvF(7.26, 7.26, 7.26) @ 2412 MHz; Calibrated: 2020/04/27

-Sensor-Surface: 2mm (Mechanical Surface Detection), z = 1.0, 31.0

touch,h24/24h2;2412,Front-lens&d0,b(1m)**Area:72x60,12 (7x6x1):** Measurement grid: dx=12mm, dy=12mm; Maximum value of SAR (measured) = 0.865 W/kg**Area:72x60,12 (61x51x1):** Interpolated grid: dx=1.200 mm, dy=1.200 mm; Maximum value of SAR (interpolated) = 1.24 W/kg**Zoom:30x30x30,5 (7x7x7)/Cube 0:** Measurement grid: dx=5mm, dy=5mm, dz=5mm;

Reference Value = 26.63 V/m; Power Drift = 0.20 dB; Maximum value of SAR (measured) = 1.21 W/kg; Peak SAR (extrapolated) = 1.75 W/kg

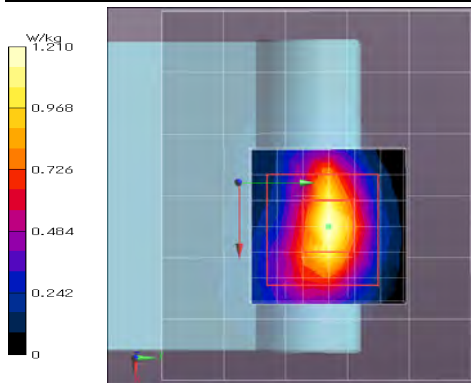
SAR(1 g) = 0.674 W/kg; SAR(10 g) = 0.260 W/kg (*. Smallest distance from peaks to all points 3 dB below = 6 mm; Ratio of SAR at M2 to SAR at M1 = 40.5%)

Remarks: *. Date tested: 2021/2/24; Tested by: Hiroshi Naka; Tested place: No.7 shielded room,
 *. liquid depth: 150 mm; Position: distance of EUT to phantom: 0 mm (2 mm to liquid); ambient: (24~25) deg.C. / (35~50) %RH,
 *. liquid temperature: 23.3(start)/23.3(end)/23.7(in check) deg.C.; *. White cubic: zoom scan area, Red cubic: big=SAR(10g) /small=SAR(1g)

Plot 1-4: Front-right(1) & touch / 11b (1Mbps) / 2437MHz**EUT: Digital Camera; Type: R05010; Serial: 0000061****Mode: 11b(1Mbps, DBPSK/DSSS)** (UID: 0, Wi-fi_2.4GHz (0), Frame Length in ms: 0; PAR: 0; PMF: 1); **Frequency: 2437 MHz; Crest Factor: 1.0****Medium: HSL2450(2102); Medium parameters used: $f = 2437$ MHz; $\sigma = 1.866$ S/m; $\epsilon_r = 37.71$; $\rho = 1000$ kg/m³**

Measurement Standard: DASYS5 (IEEE/IEC/ANSI C63.19-2007)

DASY Configuration: -Electronics: DAE4 Sn626; Calibrated: 2020/11/17 / -Phantom: ELI v4.0; Type: QDOVA001BA; Serial: 1059; Phantom section: Flat Section

-DASY52 52.10.3(1513); SEMCAD X 14.6.13(7474) / -Probe: EX3DV4 - SN3907; ConvF(7.26, 7.26, 7.26) @ 2437 MHz; Calibrated: 2020/04/27

-Sensor-Surface: 2mm (Mechanical Surface Detection), z = 1.0, 31.0

touch,h24/24h4;2437,Frnt-R(1)&d0,b(1m)**Area:72x60,12 (7x6x1):** Measurement grid: dx=12mm, dy=12mm; Maximum value of SAR (measured) = 0.772 W/kg**Area:72x60,12 (61x51x1):** Interpolated grid: dx=1.200 mm, dy=1.200 mm; Maximum value of SAR (interpolated) = 1.40 W/kg**Zoom:30x30x30,5 (7x7x7)/Cube 0:** Measurement grid: dx=5mm, dy=5mm, dz=5mm;

Reference Value = 27.66 V/m; Power Drift = 0.12 dB; Maximum value of SAR (measured) = 1.43 W/kg; Peak SAR (extrapolated) = 2.20 W/kg

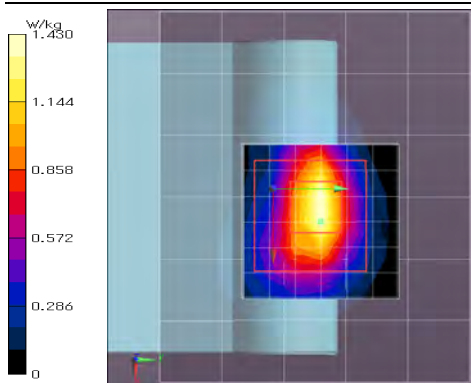
SAR(1 g) = 0.813 W/kg; SAR(10 g) = 0.301 W/kg (*. Smallest distance from peaks to all points 3 dB below = 6 mm; Ratio of SAR at M2 to SAR at M1 = 38.3%)

Remarks: *. Date tested: 2021/2/24; Tested by: Hiroshi Naka; Tested place: No.7 shielded room,
 *. liquid depth: 150 mm; Position: distance of EUT to phantom: 0 mm (2 mm to liquid); ambient: (24~25) deg.C. / (35~50) %RH,
 *. liquid temperature: 23.3(start)/23.3(end)/23.7(in check) deg.C.; *. White cubic: zoom scan area, Red cubic: big=SAR(10g) /small=SAR(1g)

Appendix 2: SAR measurement data / Appendix 2-4: Other SAR(1g) Plots (cont'd)

Plot 1-5: Front-right(1) & touch / 11b (1Mbps) / 2462MHz

EUT: Digital Camera; Type: R05010; Serial: 0000061

Mode: 11b(1Mbps, DBPSK/DSSS) (UID: 0, Wi-fi_2.4GHz (0), Frame Length in ms: 0; PAR: 0; PMF: 1); **Frequency: 2462 MHz; Crest Factor: 1.0**

Medium: HSL2450(2102); Medium parameters used: f = 2462 MHz; $\sigma = 1.896$ S/m; $\epsilon_r = 37.63$; $\rho = 1000$ kg/m³

Measurement Standard: DASYS5 (IEEE/IEC/ANSI C63.19-2007)

DASY Configuration: -Electronics: DAE4 Sn626; Calibrated: 2020/11/17 / -Phantom: ELI v4.0; Type: QDOVA001BA; Serial: 1059; Phantom section: Flat Section

-DASY52 52.10.3(1513); SEMCAD X 14.6.13(7474) / -Probe: EX3DV4 - SN3907; ConvF(7.26, 7.26, 7.26) @ 2462 MHz; Calibrated: 2020/04/27

-Sensor-Surface: 2mm (Mechanical Surface Detection), z = 1.0, 31.0, 161.0

touch,h24/24h5re;2462,Fr-R(1)&d0,b(1m)

Area:72x60,12 (7x6x1): Measurement grid: dx=12mm, dy=12mm; Maximum value of SAR (measured) = 0.959 W/kg

Area:72x60,12 (61x51x1): Interpolated grid: dx=1.200 mm, dy=1.200 mm; Maximum value of SAR (interpolated) = 1.53 W/kg

Z;160,5 (1x1x33): Measurement grid: dx=20mm, dy=20mm, dz=5mm; Maximum value of SAR (measured) = 1.56 W/kg

Zoom:30x30x30,5 (7x7x7)/Cube 0: Measurement grid: dx=5mm, dy=5mm, dz=5mm;

Reference Value = 29.42 V/m; Power Drift = -0.09 dB; Maximum value of SAR (measured) = 1.56 W/kg; Peak SAR (extrapolated) = 2.40 W/kg

SAR(1 g) = 0.871 W/kg; SAR(10 g) = 0.321 W/kg (*. Smallest distance from peaks to all points 3 dB below = 6 mm; Ratio of SAR at M2 to SAR at M1 = 37.8%)

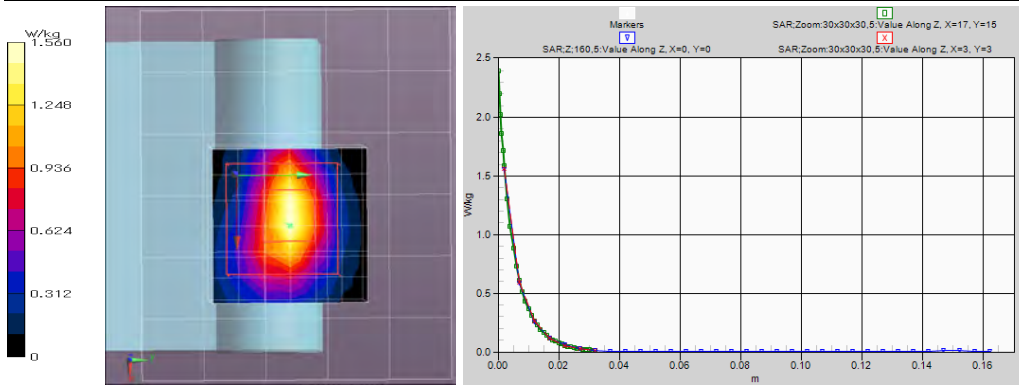

Remarks: *. Date tested: 2021/2/24; Tested by: Hiroshi Naka; Tested place: No.7 shielded room,
*. liquid depth: 150 mm; Position: distance of EUT to phantom: 0 mm (2 mm to liquid); ambient: (24~25) deg.C. / (35~50) %RH,
*. liquid temperature: 23.3(start)/23.4(end)/23.7(in check) deg.C.; *.White cubic: zoom scan area, Red cubic: big=SAR(10g)/small=SAR(1g)

Plot 1-6: Front-right(1) & touch / 11b (1Mbps) / 2412MHz

EUT: Digital Camera; Type: R05010; Serial: 0000061

Mode: 11b(1Mbps, DBPSK/DSSS) (UID: 0, Wi-fi_2.4GHz (0), Frame Length in ms: 0; PAR: 0; PMF: 1); **Frequency: 2412 MHz; Crest Factor: 1.0**

Medium: HSL2450(2102); Medium parameters used: f = 2412 MHz; $\sigma = 1.837$ S/m; $\epsilon_r = 37.82$; $\rho = 1000$ kg/m³

Measurement Standard: DASYS5 (IEEE/IEC/ANSI C63.19-2007)

DASY Configuration: -Electronics: DAE4 Sn626; Calibrated: 2020/11/17 / -Phantom: ELI v4.0; Type: QDOVA001BA; Serial: 1059; Phantom section: Flat Section

-DASY52 52.10.3(1513); SEMCAD X 14.6.13(7474) / -Probe: EX3DV4 - SN3907; ConvF(7.26, 7.26, 7.26) @ 2412 MHz; Calibrated: 2020/04/27

-Sensor-Surface: 2mm (Mechanical Surface Detection (Locations From Previous Scan Used)), Sensor-Surface: 2mm (Mechanical Surface Detection), z = 1.0, 31.0

touch,h24/24h6;2412,Fr-R(1)&d0,b(1m)

Area:72x60,12 (7x6x1): Measurement grid: dx=12mm, dy=12mm; Maximum value of SAR (measured) = 0.792 W/kg

Area:72x60,12 (61x51x1): Interpolated grid: dx=1.200 mm, dy=1.200 mm; Maximum value of SAR (interpolated) = 1.51 W/kg

Zoom:30x30x30,5 (7x7x7)/Cube 0: Measurement grid: dx=5mm, dy=5mm, dz=5mm;

Reference Value = 28.82 V/m; Power Drift = -0.02 dB; Maximum value of SAR (measured) = 1.49 W/kg; Peak SAR (extrapolated) = 2.23 W/kg

SAR(1 g) = 0.828 W/kg; SAR(10 g) = 0.307 W/kg (*. Smallest distance from peaks to all points 3 dB below = 6 mm; Ratio of SAR at M2 to SAR at M1 = 38.8%)

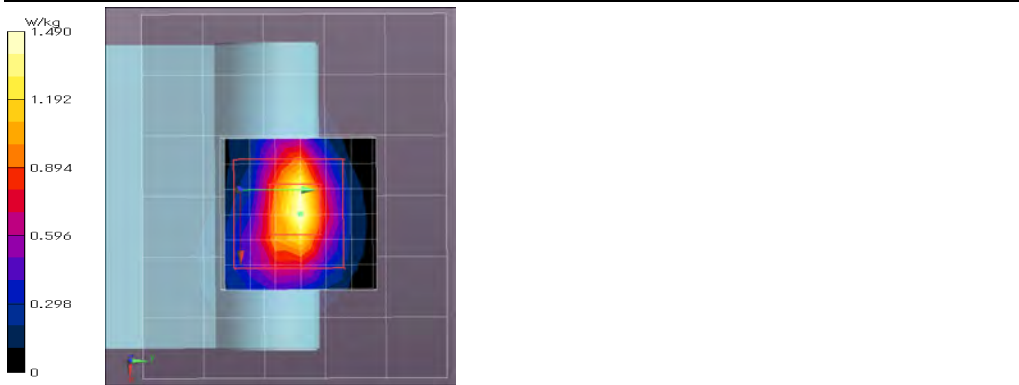

Remarks: *. Date tested: 2021/2/24; Tested by: Hiroshi Naka; Tested place: No.7 shielded room,
*. liquid depth: 150 mm; Position: distance of EUT to phantom: 0 mm (2 mm to liquid); ambient: (24~25) deg.C. / (35~50) %RH,
*. liquid temperature: 23.4(start)/23.4(end)/23.7(in check) deg.C.; *.White cubic: zoom scan area, Red cubic: big=SAR(10g)/small=SAR(1g)

Appendix 2: SAR measurement data / Appendix 2-4: Other SAR(1g) Plots (cont'd)

Plot 1-7: Front-right(2) & touch / 11b (1Mbps) / 2437MHz

EUT: Digital Camera; Type: R05010; Serial: 0000061

Mode: 11b(1Mbps, DBPSK/DSSS) (UID: 0, Wi-fi_2.4GHz (0), Frame Length in ms: 0; PAR: 0; PMF: 1); **Frequency: 2437 MHz; Crest Factor: 1.0**

Medium: HSL2450(2102); Medium parameters used: f = 2437 MHz; $\sigma = 1.866$ S/m; $\epsilon_r = 37.71$; $\rho = 1000$ kg/m³

Measurement Standard: DASYS5 (IEEE/IEC/ANSI C63.19-2007)

DASY Configuration: -Electronics: DAE4 Sn626; Calibrated: 2020/11/17 / -Phantom: ELI v4.0; Type: QDOVA001BA; Serial: 1059; Phantom section: Flat Section

-DASY52 52.10.3(1513); SEMCAD X 14.6.13(7474) / -Probe: EX3DV4 - SN3907; ConvF(7.26, 7.26, 7.26) @ 2437 MHz; Calibrated: 2020/04/27

-Sensor-Surface: 2mm (Mechanical Surface Detection), z = 1.0, 31.0

touch,h24/24h7;2437,Fr-R(3)&d0,b(1m)

Area:72x60,12 (7x6x1): Measurement grid: dx=12mm, dy=12mm; Maximum value of SAR (measured) = 1.26 W/kg

Area:72x60,12 (61x51x1): Interpolated grid: dx=1.200 mm, dy=1.200 mm; Maximum value of SAR (interpolated) = 1.37 W/kg

Zoom:30x30x30,5 (7x7x7)/Cube 0: Measurement grid: dx=5mm, dy=5mm, dz=5mm;

Reference Value = 27.91 V/m; Power Drift = 0.01 dB; Maximum value of SAR (measured) = 1.38 W/kg; Peak SAR (extrapolated) = 2.08 W/kg

SAR(1 g) = 0.765 W/kg; SAR(10 g) = 0.278 W/kg (*. Smallest distance from peaks to all points 3 dB below = 6 mm; Ratio of SAR at M2 to SAR at M1 = 38.8%)

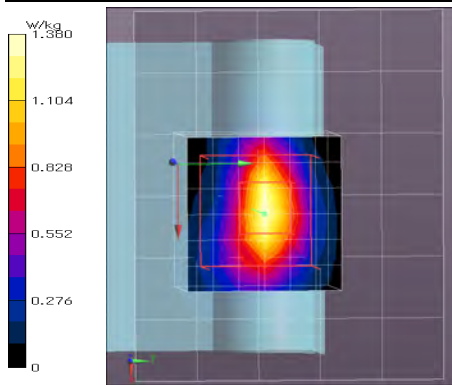

Remarks: * Date tested: 2021/2/24; Tested by: Hiroshi Naka; Tested place: No.7 shielded room,
 * liquid depth: 150 mm; Position: distance of EUT to phantom: 0 mm (2 mm to liquid); ambient: (24~25) deg.C. / (35~50) %RH,
 * liquid temperature: 23.4(start)/23.3(end)/23.7(in check) deg.C.; *.White cubic: zoom scan area, Red cubic: big=SAR(10g)/small=SAR(1g)

Plot 1-8: Front-right(2) & touch / 11b (1Mbps) / 2462MHz

EUT: Digital Camera; Type: R05010; Serial: 0000061

Mode: 11b(1Mbps, DBPSK/DSSS) (UID: 0, Wi-fi_2.4GHz (0), Frame Length in ms: 0; PAR: 0; PMF: 1); **Frequency: 2462 MHz; Crest Factor: 1.0**

Medium: HSL2450(2102); Medium parameters used: f = 2462 MHz; $\sigma = 1.896$ S/m; $\epsilon_r = 37.63$; $\rho = 1000$ kg/m³

Measurement Standard: DASYS5 (IEEE/IEC/ANSI C63.19-2007)

DASY Configuration: -Electronics: DAE4 Sn626; Calibrated: 2020/11/17 / -Phantom: ELI v4.0; Type: QDOVA001BA; Serial: 1059; Phantom section: Flat Section

-DASY52 52.10.3(1513); SEMCAD X 14.6.13(7474) / -Probe: EX3DV4 - SN3907; ConvF(7.26, 7.26, 7.26) @ 2462 MHz; Calibrated: 2020/04/27

-Sensor-Surface: 2mm (Mechanical Surface Detection (Locations From Previous Scan Used)), Sensor-Surface: 2mm (Mechanical Surface Detection), z = 1.0, 31.0

touch,h24/24h8;2462,Fr-R(3)&d0,b(1m)

Area:72x60,12 (7x6x1): Measurement grid: dx=12mm, dy=12mm; Maximum value of SAR (measured) = 1.26 W/kg

Area:72x60,12 (61x51x1): Interpolated grid: dx=1.200 mm, dy=1.200 mm; Maximum value of SAR (interpolated) = 1.40 W/kg

Zoom:30x30x30,5 (7x7x7)/Cube 0: Measurement grid: dx=5mm, dy=5mm, dz=5mm;

Reference Value = 29.17 V/m; Power Drift = 0.02 dB; Maximum value of SAR (measured) = 1.53 W/kg; Peak SAR (extrapolated) = 2.29 W/kg

SAR(1 g) = 0.817 W/kg; SAR(10 g) = 0.307 W/kg (*. Smallest distance from peaks to all points 3 dB below = 5.8 mm; Ratio of SAR at M2 to SAR at M1 = 38.9%)

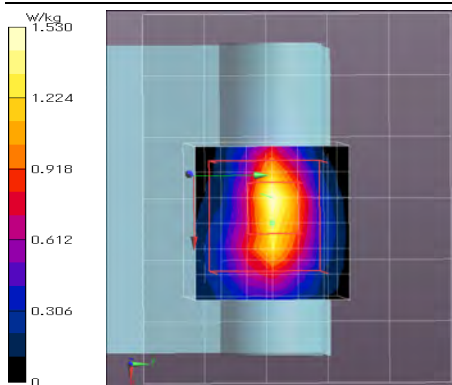

Remarks: * Date tested: 2021/2/24; Tested by: Hiroshi Naka; Tested place: No.7 shielded room,
 * liquid depth: 150 mm; Position: distance of EUT to phantom: 0 mm (2 mm to liquid); ambient: (24~25) deg.C. / (35~50) %RH,
 * liquid temperature: 23.3(start)/23.3(end)/23.7(in check) deg.C.; *.White cubic: zoom scan area, Red cubic: big=SAR(10g)/small=SAR(1g)

Appendix 2: SAR measurement data / Appendix 2-4: Other SAR(1g) Plots (cont'd)**Plot 1-9: Front-right(2) & touch / 11b (1Mbps) / 2412MHz****EUT: Digital Camera; Type: R05010; Serial: 0000061****Mode: 11b(1Mbps, DBPSK/DSSS)** (UID: 0, Wi-fi_2.4GHz (0), Frame Length in ms: 0, PAR: 0, PMF: 1); **Frequency: 2412 MHz; Crest Factor: 1.0****Medium: HSL2450(2102); Medium parameters used: f = 2412 MHz; $\sigma = 1.837$ S/m; $\epsilon_r = 37.82$; $\rho = 1000$ kg/m³**

Measurement Standard: DASYS5 (IEEE/IEC/ANSI C63.19-2007)

DASY Configuration: -Electronics: DAE4 Sn626; Calibrated: 2020/11/17 / -Phantom: ELI v4.0; Type: QDOVA001BA; Serial: 1059; Phantom section: Flat Section

-DASY52 52.10.3(1513); SEMCAD X 14.6.13(7474) / -Probe: EX3DV4 - SN3907; ConvF(7.26, 7.26, 7.26) @ 2412 MHz; Calibrated: 2020/04/27

-Sensor-Surface: 2mm (Mechanical Surface Detection (Locations From Previous Scan Used)), Sensor-Surface: 2mm (Mechanical Surface Detection), z = 1.0, 31.0

touch,h24/24h9;2412,Frt-R(3)&d0,b(1m)**Area:72x60,12 (7x6x1):** Measurement grid: dx=12mm, dy=12mm; Maximum value of SAR (measured) = 1.20 W/kg**Area:72x60,12 (61x51x1):** Interpolated grid: dx=1.200 mm, dy=1.200 mm; Maximum value of SAR (interpolated) = 1.33 W/kg**Zoom:30x30x30,5 (7x7x7)/Cube 0:** Measurement grid: dx=5mm, dy=5mm, dz=5mm;

Reference Value = 27.44 V/m; Power Drift = 0.20 dB; Maximum value of SAR (measured) = 1.49 W/kg; Peak SAR (extrapolated) = 2.23 W/kg

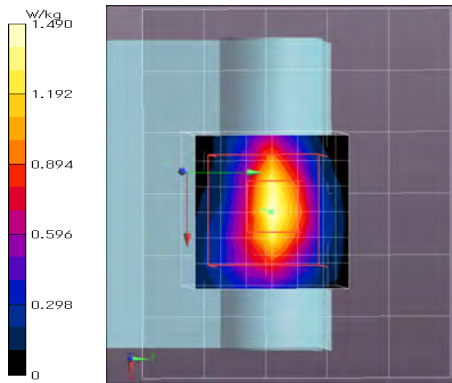
SAR(1 g) = 0.801 W/kg; SAR(10 g) = 0.300 W/kg (*. Smallest distance from peaks to all points 3 dB below = 6 mm; Ratio of SAR at M2 to SAR at M1 = 39.2%)

Remarks: * Date tested: 2021/2/24; Tested by: Hiroshi Naka; Tested place: No.7 shielded room,

* liquid depth: 150 mm; Position: distance of EUT to phantom: 0 mm (2 mm to liquid); ambient: (24~25) deg.C. / (35~50) %RH,

* liquid temperature: 23.3(start)/23.3(end)/23.7(in check) deg.C.; *. White cubic: zoom scan area, Red cubic: big=SAR(10g)/small=SAR(1g)

Plot 1-10: Right-front & touch / 11b (1Mbps) / 2437MHz**EUT: Digital Camera; Type: R05010; Serial: 0000061****Mode: 11b(1Mbps, DBPSK/DSSS)** (UID: 0, Wi-fi_2.4GHz (0), Frame Length in ms: 0, PAR: 0, PMF: 1); **Frequency: 2437 MHz; Crest Factor: 1.0****Medium: HSL2450(2102); Medium parameters used: f = 2437 MHz; $\sigma = 1.866$ S/m; $\epsilon_r = 37.71$; $\rho = 1000$ kg/m³**

Measurement Standard: DASYS5 (IEEE/IEC/ANSI C63.19-2007)

DASY Configuration: -Electronics: DAE4 Sn626; Calibrated: 2020/11/17 / -Phantom: ELI v4.0; Type: QDOVA001BA; Serial: 1059; Phantom section: Flat Section

-DASY52 52.10.3(1513); SEMCAD X 14.6.13(7474) / -Probe: EX3DV4 - SN3907; ConvF(7.26, 7.26, 7.26) @ 2437 MHz; Calibrated: 2020/04/27

-Sensor-Surface: 2mm (Mechanical Surface Detection (Locations From Previous Scan Used)), Sensor-Surface: 2mm (Mechanical Surface Detection), z = 1.0, 31.0

touch,h24,3/24h22re2;2437,R-frt&d0,b(1m)**Area:72x72,12 (7x7x1):** Measurement grid: dx=12mm, dy=12mm; Maximum value of SAR (measured) = 1.14 W/kg**Area:72x72,12 (61x61x1):** Interpolated grid: dx=1.200 mm, dy=1.200 mm; Maximum value of SAR (interpolated) = 1.24 W/kg**Zoom:30x30x30,5 (8x7x7)/Cube 0:** Measurement grid: dx=5mm, dy=5mm, dz=5mm;

Reference Value = 27.96 V/m; Power Drift = -0.01 dB; Maximum value of SAR (measured) = 1.48 W/kg; Peak SAR (extrapolated) = 2.28 W/kg

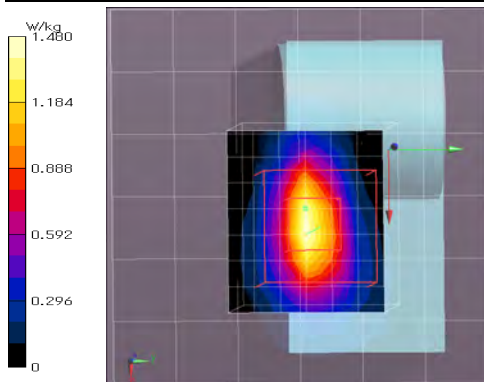
SAR(1 g) = 0.806 W/kg; SAR(10 g) = 0.286 W/kg (*. Smallest distance from peaks to all points 3 dB below = 6 mm; Ratio of SAR at M2 to SAR at M1 = 37.6%)

Remarks: * Date tested: 2021/2/25; Tested by: Hiroshi Naka; Tested place: No.7 shielded room,

* liquid depth: 150 mm; Position: distance of EUT to phantom: 0 mm (2 mm to liquid); ambient: (24~25) deg.C. / (35~50) %RH,

* liquid temperature: 23.4(start)/23.3(end)/23.7(in check) deg.C.; *. White cubic: zoom scan area, Red cubic: big=SAR(10g)/small=SAR(1g)

UL Japan, Inc.**Shonan EMC Lab.**

1-22-3 Megumigaoka, Hiratsuka-shi, Kanagawa-ken, 259-1220 JAPAN

Telephone: +81 463 50 6400 / Facsimile: +81 463 50 6401

Report Cover Page - 13-EM-F0429 Issue # 19.0

Appendix 2: SAR measurement data / Appendix 2-4: Other SAR(1g) Plots (cont'd)

Plot 1-11: Right-front & touch / 11b (1Mbps) / 2462MHz

EUT: Digital Camera; Type: R05010; Serial: 0000061

Mode: 11b(1Mbps, DBPSK/DSSS) (UID: 0, Wi-fi_2.4GHz (0), Frame Length in ms: 0; PAR: 0; PMF: 1); **Frequency: 2462 MHz; Crest Factor: 1.0**

Medium: HSL2450(2102); Medium parameters used: f = 2462 MHz; $\sigma = 1.896$ S/m; $\epsilon_r = 37.63$; $\rho = 1000$ kg/m³

Measurement Standard: DASYS5 (IEEE/IEC/ANSI C63.19-2007)

DASY Configuration: -Electronics: DAE4 Sn626; Calibrated: 2020/11/17 / -Phantom: ELI v4.0; Type: QDOVA001BA; Serial: 1059; Phantom section: Flat Section

-DASY52 52.10.3(1513); SEMCAD X 14.6.13(7474) / -Probe: EX3DV4 - SN3907; ConvF(7.26, 7.26, 7.26) @ 2462 MHz; Calibrated: 2020/04/27

-Sensor-Surface: 2mm (Mechanical Surface Detection (Locations From Previous Scan Used)), Sensor-Surface: 2mm (Mechanical Surface Detection), z = 1.0, 31.0

touch,h24,3/24h27;2462,R-rt&d0,b(1m)

Area:72x72,12 (7x7x1): Measurement grid: dx=12mm, dy=12mm; Maximum value of SAR (measured) = 1.18 W/kg

Area:72x72,12 (61x61x1): Interpolated grid: dx=1.200 mm, dy=1.200 mm; Maximum value of SAR (interpolated) = 1.31 W/kg

Zoom:30x30x30,5 (7x7x7)/Cube 0: Measurement grid: dx=5mm, dy=5mm, dz=5mm;

Reference Value = 28.36 V/m; Power Drift = 0.04 dB; Maximum value of SAR (measured) = 1.53 W/kg; Peak SAR (extrapolated) = 2.32 W/kg

SAR(1 g) = 0.814 W/kg; SAR(10 g) = 0.289 W/kg (*. Smallest distance from peaks to all points 3 dB below = 5 mm; Ratio of SAR at M2 to SAR at M1 = 37.3%)

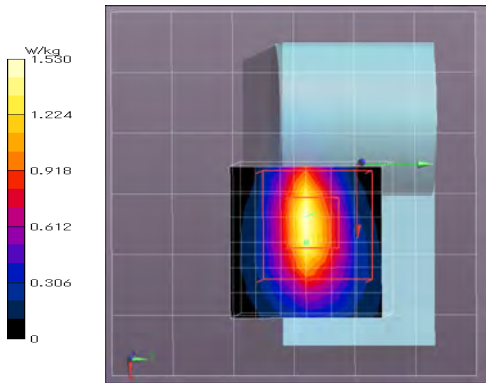

Remarks: * Date tested: 2021/2/25; Tested by: Hiroshi Naka; Tested place: No.7 shielded room,
 * liquid depth: 150 mm; Position: distance of EUT to phantom: 0 mm (2 mm to liquid); ambient: (24~25) deg.C. / (35~50) %RH,
 * liquid temperature: 23.3(start)/23.3(end)/23.7(in check) deg.C.; * White cubic: zoom scan area, Red cubic: big=SAR(10g) / small=SAR(1g)

Plot 1-12: Right-front & touch / 11b (1Mbps) / 2412MHz

EUT: Digital Camera; Type: R05010; Serial: 0000061

Mode: 11b(1Mbps, DBPSK/DSSS) (UID: 0, Wi-fi_2.4GHz (0), Frame Length in ms: 0; PAR: 0; PMF: 1); **Frequency: 2412 MHz; Crest Factor: 1.0**

Medium: HSL2450(2102); Medium parameters used: f = 2412 MHz; $\sigma = 1.837$ S/m; $\epsilon_r = 37.82$; $\rho = 1000$ kg/m³

Measurement Standard: DASYS5 (IEEE/IEC/ANSI C63.19-2007)

DASY Configuration: -Electronics: DAE4 Sn626; Calibrated: 2020/11/17 / -Phantom: ELI v4.0; Type: QDOVA001BA; Serial: 1059; Phantom section: Flat Section

-DASY52 52.10.3(1513); SEMCAD X 14.6.13(7474) / -Probe: EX3DV4 - SN3907; ConvF(7.26, 7.26, 7.26) @ 2412 MHz; Calibrated: 2020/04/27

-Sensor-Surface: 2mm (Mechanical Surface Detection (Locations From Previous Scan Used)), Sensor-Surface: 2mm (Mechanical Surface Detection), z = 1.0, 31.0

touch,h24,3/24h28;2412,R-rt&d0,b(1m)

Area:72x72,12 (7x7x1): Measurement grid: dx=12mm, dy=12mm; Maximum value of SAR (measured) = 1.15 W/kg

Area:72x72,12 (61x61x1): Interpolated grid: dx=1.200 mm, dy=1.200 mm; Maximum value of SAR (interpolated) = 1.27 W/kg

Zoom:30x30x30,5 (8x7x7)/Cube 0: Measurement grid: dx=5mm, dy=5mm, dz=5mm;

Reference Value = 27.72 V/m; Power Drift = -0.19 dB; Maximum value of SAR (measured) = 1.41 W/kg; Peak SAR (extrapolated) = 2.27 W/kg

SAR(1 g) = 0.806 W/kg; SAR(10 g) = 0.287 W/kg (*. Smallest distance from peaks to all points 3 dB below = 5.1 mm; Ratio of SAR at M2 to SAR at M1 = 38.8%)

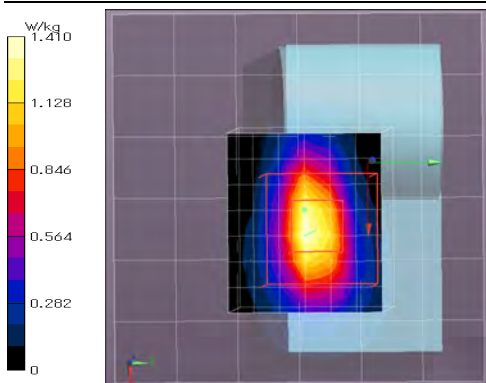

Remarks: * Date tested: 2021/2/25; Tested by: Hiroshi Naka; Tested place: No.7 shielded room,
 * liquid depth: 150 mm; Position: distance of EUT to phantom: 0 mm (2 mm to liquid); ambient: (24~25) deg.C. / (35~50) %RH,
 * liquid temperature: 23.3(start)/23.4(end)/23.7(in check) deg.C.; * White cubic: zoom scan area, Red cubic: big=SAR(10g) / small=SAR(1g)

Appendix 2: SAR measurement data / Appendix 2-4: Other SAR(1g) Plots (cont'd)**Plot 1-13: Right & touch / 11b (1Mbps) / 2437MHz****EUT: Digital Camera; Type: R05010; Serial: 0000061****Mode: 11b(1Mbps, DBPSK/DSSS)** (UID: 0, Wi-fi_2.4GHz (0), Frame Length in ms: 0; PAR: 0; PMF: 1); **Frequency: 2437 MHz; Crest Factor: 1.0****Medium: HSL2450(2102); Medium parameters used: f = 2437 MHz; $\sigma = 1.866$ S/m; $\epsilon_r = 37.71$; $\rho = 1000$ kg/m³**

Measurement Standard: DASY5 (IEEE/IEC/ANSI C63.19-2007)

DASY Configuration: -Electronics: DAE4 Sn626; Calibrated: 2020/11/17 / -Phantom: ELI v4.0; Type: QDOVA001BA; Serial: 1059; Phantom section: Flat Section

-DASY52 52.10.3(1513); SEMCAD X 14.6.13(7474) / -Probe: EX3DV4 - SN3907; ConvF(7.26, 7.26, 7.26) @ 2437 MHz; Calibrated: 2020/04/27

-Sensor-Surface: 2mm (Mechanical Surface Detection), z = 1.0, 31.0

touch,h24,3/24h23;2437,Right&d0,b(1m)**Area:72x72,12 (7x7x1):** Measurement grid: dx=12mm, dy=12mm; Maximum value of SAR (measured) = 0.808 W/kg**Area:72x72,12 (61x61x1):** Interpolated grid: dx=1.200 mm, dy=1.200 mm; Maximum value of SAR (interpolated) = 0.999 W/kg**Zoom:30x30x30,5 (7x7x7)/Cube 0:** Measurement grid: dx=5mm, dy=5mm, dz=5mm;

Reference Value = 25.76 V/m; Power Drift = -0.06 dB; Maximum value of SAR (measured) = 1.19 W/kg; Peak SAR (extrapolated) = 1.94 W/kg

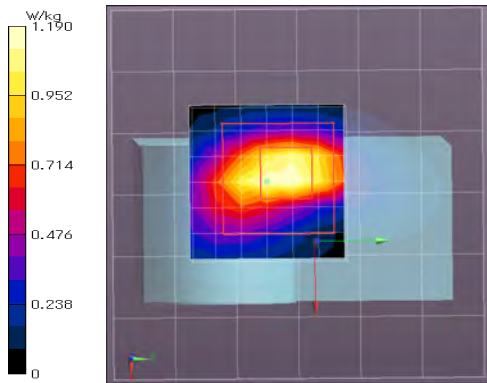
SAR(1 g) = 0.728 W/kg; SAR(10 g) = 0.282 W/kg (*. Smallest distance from peaks to all points 3 dB below = 5.8 mm; Ratio of SAR at M2 to SAR at M1 = 40.2%)

Remarks: * Date tested: 2021/2/25; Tested by: Hiroshi Naka; Tested place: No.7 shielded room.
 * liquid depth: 150 mm; Position: distance of EUT to phantom: 0 mm (2 mm to liquid); ambient: (24~25) deg.C. / (35~50) %RH,
 * liquid temperature: 23.4(start)/23.4(end)/23.7(in check) deg.C.; *.White cubic: zoom scan area, Red cubic: big=SAR(10g)/small=SAR(1g)

Plot 1-14: Right & touch / 11b (1Mbps) / 2462MHz**EUT: Digital Camera; Type: R05010; Serial: 0000061****Mode: 11b(1Mbps, DBPSK/DSSS)** (UID: 0, Wi-fi_2.4GHz (0), Frame Length in ms: 0; PAR: 0; PMF: 1); **Frequency: 2462 MHz; Crest Factor: 1.0****Medium: HSL2450(2102); Medium parameters used: f = 2462 MHz; $\sigma = 1.896$ S/m; $\epsilon_r = 37.63$; $\rho = 1000$ kg/m³**

Measurement Standard: DASY5 (IEEE/IEC/ANSI C63.19-2007)

DASY Configuration: -Electronics: DAE4 Sn626; Calibrated: 2020/11/17 / -Phantom: ELI v4.0; Type: QDOVA001BA; Serial: 1059; Phantom section: Flat Section

-DASY52 52.10.3(1513); SEMCAD X 14.6.13(7474) / -Probe: EX3DV4 - SN3907; ConvF(7.26, 7.26, 7.26) @ 2462 MHz; Calibrated: 2020/04/27

-Sensor-Surface: 2mm (Mechanical Surface Detection), z = 1.0, 31.0

touch,h24,3/24h24;2462,Right&d0,b(1m)**Area:72x72,12 (7x7x1):** Measurement grid: dx=12mm, dy=12mm; Maximum value of SAR (measured) = 0.887 W/kg**Area:72x72,12 (61x61x1):** Interpolated grid: dx=1.200 mm, dy=1.200 mm; Maximum value of SAR (interpolated) = 1.10 W/kg**Zoom:30x30x30,5 (7x7x7)/Cube 0:** Measurement grid: dx=5mm, dy=5mm, dz=5mm;

Reference Value = 25.67 V/m; Power Drift = 0.14 dB; Maximum value of SAR (measured) = 1.21 W/kg; Peak SAR (extrapolated) = 1.97 W/kg

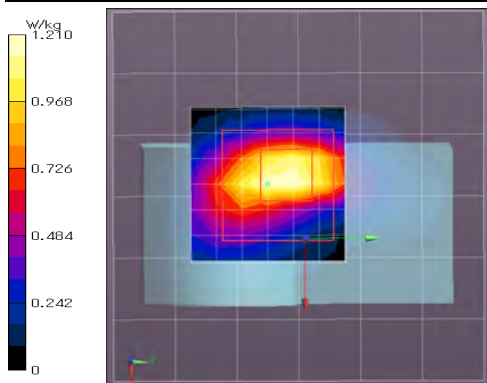
SAR(1 g) = 0.736 W/kg; SAR(10 g) = 0.285 W/kg (*. Smallest distance from peaks to all points 3 dB below = 6 mm; Ratio of SAR at M2 to SAR at M1 = 40%)

Remarks: * Date tested: 2021/2/25; Tested by: Hiroshi Naka; Tested place: No.7 shielded room.
 * liquid depth: 150 mm; Position: distance of EUT to phantom: 0 mm (2 mm to liquid); ambient: (24~25) deg.C. / (35~50) %RH,
 * liquid temperature: 23.4(start)/23.5(end)/23.7(in check) deg.C.; *.White cubic: zoom scan area, Red cubic: big=SAR(10g)/small=SAR(1g)

UL Japan, Inc.**Shonan EMC Lab.**

1-22-3 Megumigaoka, Hiratsuka-shi, Kanagawa-ken, 259-1220 JAPAN

Telephone: +81 463 50 6400 / Facsimile: +81 463 50 6401

Report Cover Page - 13-EM-F0429 Issue # 19.0

Appendix 2: SAR measurement data / Appendix 2-4: Other SAR(1g) Plots (cont'd)**Plot 1-15: Right & touch / 11b (1Mbps) / 2412MHz****EUT: Digital Camera; Type: R05010; Serial: 0000061****Mode: 11b(1Mbps, DBPSK/DSSS)** (UID: 0, Wi-fi_2.4GHz (0), Frame Length in ms: 0; PAR: 0; PMF: 1); **Frequency: 2412 MHz; Crest Factor: 1.0****Medium: HSL2450(2102); Medium parameters used: f = 2412 MHz; $\sigma = 1.837$ S/m; $\epsilon_r = 37.82$; $\rho = 1000$ kg/m³**

Measurement Standard: DASYS (IEEE/IEC/ANSI C63.19-2007)

DASY Configuration: -Electronics: DAE4 Sn626; Calibrated: 2020/11/17 / -Phantom: ELI v4.0; Type: QDOVA001BA; Serial: 1059; Phantom section: Flat Section

-DASY52 52.10.3(1513); SEMCAD X 14.6.13(7474) / -Probe: EX3DV4 - SN3907; ConvF(7.26, 7.26, 7.26) @ 2412 MHz; Calibrated: 2020/04/27

-Sensor-Surface: 2mm (Mechanical Surface Detection (Locations From Previous Scan Used)), Sensor-Surface: 2mm (Mechanical Surface Detection), z = 1.0, 31.0

touch,h24,3/24h25;2412,Right&d0,b(1m)**Area:72x72,12 (7x7x1):** Measurement grid: dx=12mm, dy=12mm; Maximum value of SAR (measured) = 0.781 W/kg**Area:72x72,12 (61x61x1):** Interpolated grid: dx=1.200 mm, dy=1.200 mm; Maximum value of SAR (interpolated) = 0.963 W/kg**Zoom:30x30x30,5 (7x7x7)/Cube 0:** Measurement grid: dx=5mm, dy=5mm, dz=5mm;

Reference Value = 23.96 V/m; Power Drift = -0.09 dB; Maximum value of SAR (measured) = 1.01 W/kg; Peak SAR (extrapolated) = 1.67 W/kg

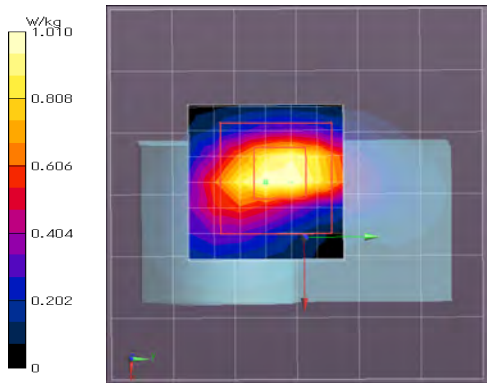
SAR(1 g) = 0.624 W/kg; SAR(10 g) = 0.242 W/kg (*. Smallest distance from peaks to all points 3 dB below = 5.4 mm; Ratio of SAR at M2 to SAR at M1 = 40.5%)

Remarks: * Date tested: 2021/2/25; Tested by: Hiroshi Naka; Tested place: No.7 shielded room,
 * liquid depth: 150 mm; Position: distance of EUT to phantom: 0 mm (2 mm to liquid); ambient: (24~25) deg.C. / (35~50) %RH,
 * liquid temperature: 23.5(start)/23.4(end)/23.7(in check) deg.C.; *. White cubic: zoom scan area, Red cubic: big=SAR(10g)/small=SAR(1g)

Plot 1-16: Top-front & touch / 11b (1Mbps) / 2437MHz**EUT: Digital Camera; Type: R05010; Serial: 0000061****Mode: 11b(1Mbps, DBPSK/DSSS)** (UID: 0, Wi-fi_2.4GHz (0), Frame Length in ms: 0; PAR: 0; PMF: 1); **Frequency: 2437 MHz; Crest Factor: 1.0****Medium: HSL2450(2102); Medium parameters used: f = 2437 MHz; $\sigma = 1.866$ S/m; $\epsilon_r = 37.71$; $\rho = 1000$ kg/m³**

Measurement Standard: DASYS (IEEE/IEC/ANSI C63.19-2007)

DASY Configuration: -Electronics: DAE4 Sn626; Calibrated: 2020/11/17 / -Phantom: ELI v4.0; Type: QDOVA001BA; Serial: 1059; Phantom section: Flat Section

-DASY52 52.10.3(1513); SEMCAD X 14.6.13(7474) / -Probe: EX3DV4 - SN3907; ConvF(7.26, 7.26, 7.26) @ 2437 MHz; Calibrated: 2020/04/27

-Sensor-Surface: 2mm (Mechanical Surface Detection), z = 1.0, 31.0

touch,h24,3/24h30;2437,Top-frnt&d0,b(1m)**Area:144x60,12 (13x6x1):** Measurement grid: dx=12mm, dy=12mm; Maximum value of SAR (measured) = 0.150 W/kg**Area:144x60,12 (121x51x1):** Interpolated grid: dx=1.200 mm, dy=1.200 mm; Maximum value of SAR (interpolated) = 0.167 W/kg**Zoom:30x30x30,5 (7x7x7)/Cube 0:** Measurement grid: dx=5mm, dy=5mm, dz=5mm;

Reference Value = 9.639 V/m; Power Drift = -0.14 dB; Maximum value of SAR (measured) = 0.162 W/kg; Peak SAR (extrapolated) = 0.225 W/kg

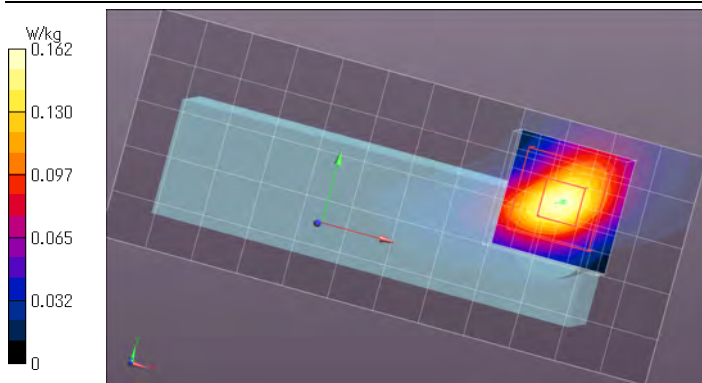
SAR(1 g) = 0.104 W/kg; SAR(10 g) = 0.048 W/kg (*. Smallest distance from peaks to all points 3 dB below = 9.4 mm; Ratio of SAR at M2 to SAR at M1 = 46.9%)

Remarks: * Date tested: 2021/2/25; Tested by: Hiroshi Naka; Tested place: No.7 shielded room,
 * liquid depth: 150 mm; Position: distance of EUT to phantom: 0 mm (2 mm to liquid); ambient: (24~25) deg.C. / (35~50) %RH,
 * liquid temperature: 23.3(start)/23.3(end)/23.7(in check) deg.C.; *. White cubic: zoom scan area, Red cubic: big=SAR(10g)/small=SAR(1g)

Appendix 2: SAR measurement data / Appendix 2-4: Other SAR(1g) Plots (cont'd)

Plot 1-17: Top & touch / 11b (1Mbps) / 2437MHz

EUT: Digital Camera; Type: R05010; Serial: 0000061

Mode: 11b(1Mbps, DBPSK/DSSS) (UID: 0, Wi-fi_2.4GHz (0), Frame Length in ms: 0; PAR: 0; PMF: 1); **Frequency: 2437 MHz; Crest Factor: 1.0**

Medium: HSL2450(2102); Medium parameters used: f = 2437 MHz; $\sigma = 1.866$ S/m; $\epsilon_r = 37.71$; $\rho = 1000$ kg/m³

Measurement Standard: DASYS (IEEE/IEC/ANSI C63.19-2007)

DASY Configuration: -Electronics: DAE4 Sn626; Calibrated: 2020/11/17 / -Phantom: ELI v4.0; Type: QDOVA001BA; Serial: 1059; Phantom section: Flat Section

-DASY52 52.10.3(1513); SEMCAD X 14.6.13(7474) / -Probe: EX3DV4 - SN3907; ConvF(7.26, 7.26, 7.26) @ 2437 MHz; Calibrated: 2020/04/27

-Sensor-Surface: 2mm (Mechanical Surface Detection), z = 1.0, 31.0

touch,h24,3/24h31;2437,Top&d0,b(1m)

Area:60x144,12 (6x13x1): Measurement grid: dx=12mm, dy=12mm; Maximum value of SAR (measured) = 0.104 W/kg

Area:60x144,12 (51x121x1): Interpolated grid: dx=1.200 mm, dy=1.200 mm; Maximum value of SAR (interpolated) = 0.108 W/kg

Zoom:30x30x30,5 (7x7x7)/Cube 0: Measurement grid: dx=5mm, dy=5mm, dz=5mm;

Reference Value = 7.725 V/m; Power Drift = -0.04 dB; Maximum value of SAR (measured) = 0.106 W/kg; Peak SAR (extrapolated) = 0.145 W/kg

SAR(1 g) = 0.070 W/kg; SAR(10 g) = 0.034 W/kg (*. Smallest distance from peaks to all points 3 dB below = 10.6 mm; Ratio of SAR at M2 to SAR at M1 = 47.4%)

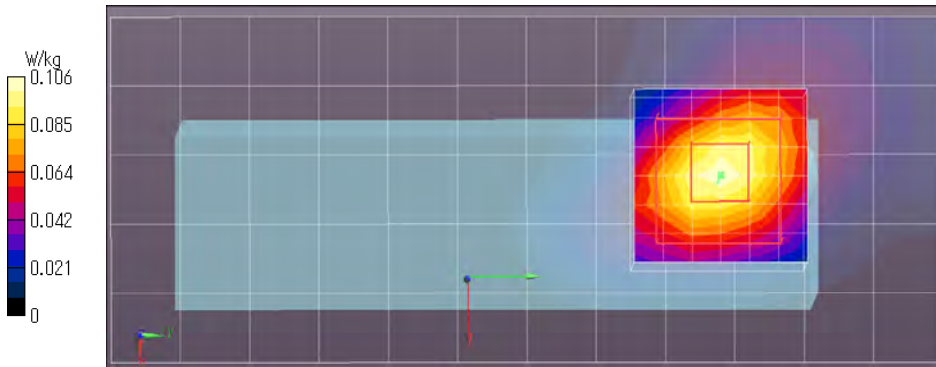

Remarks: *. Date tested: 2021/2/25; Tested by: Hiroshi Naka; Tested place: No.7 shielded room,
*. liquid depth: 150 mm; Position: distance of EUT to phantom: 0 mm (2 mm to liquid); ambient: (24~25) deg.C. / (35~50) %RH,
*. liquid temperature: 23.3(start)/23.2(end)/23.7(in check) deg.C.; *. White cubic: zoom scan area, Red cubic: big-SAR(10g) / small-SAR(1g)

Plot 1-18: Bottom & touch / 11b (1Mbps) / 2437MHz

EUT: Digital Camera; Type: R05010; Serial: 0000061

Mode: 11b(1Mbps, DBPSK/DSSS) (UID: 0, Wi-fi_2.4GHz (0), Frame Length in ms: 0; PAR: 0; PMF: 1); **Frequency: 2437 MHz; Crest Factor: 1.0**

Medium: HSL2450(2102); Medium parameters used: f = 2437 MHz; $\sigma = 1.866$ S/m; $\epsilon_r = 37.71$; $\rho = 1000$ kg/m³

Measurement Standard: DASYS (IEEE/IEC/ANSI C63.19-2007)

DASY Configuration: -Electronics: DAE4 Sn626; Calibrated: 2020/11/17 / -Phantom: ELI v4.0; Type: QDOVA001BA; Serial: 1059; Phantom section: Flat Section

-DASY52 52.10.3(1513); SEMCAD X 14.6.13(7474) / -Probe: EX3DV4 - SN3907; ConvF(7.26, 7.26, 7.26) @ 2437 MHz; Calibrated: 2020/04/27

-Sensor-Surface: 2mm (Mechanical Surface Detection), z = 1.0, 31.0

touch,h24,3/24h32;2437,bottom&d0,b(1m)

Area:60x144,12 (6x13x1): Measurement grid: dx=12mm, dy=12mm; Maximum value of SAR (measured) = 0.0527 W/kg

Area:60x144,12 (51x121x1): Interpolated grid: dx=1.200 mm, dy=1.200 mm; Maximum value of SAR (interpolated) = 0.0603 W/kg

Zoom:30x30x30,5 (7x7x7)/Cube 0: Measurement grid: dx=5mm, dy=5mm, dz=5mm;

Reference Value = 5.346 V/m; Power Drift = -0.05 dB; Maximum value of SAR (measured) = 0.0512 W/kg; Peak SAR (extrapolated) = 0.0740 W/kg

SAR(1 g) = 0.034 W/kg; SAR(10 g) = 0.015 W/kg (*. Ratio of SAR at M2 to SAR at M1 = 48.5%)

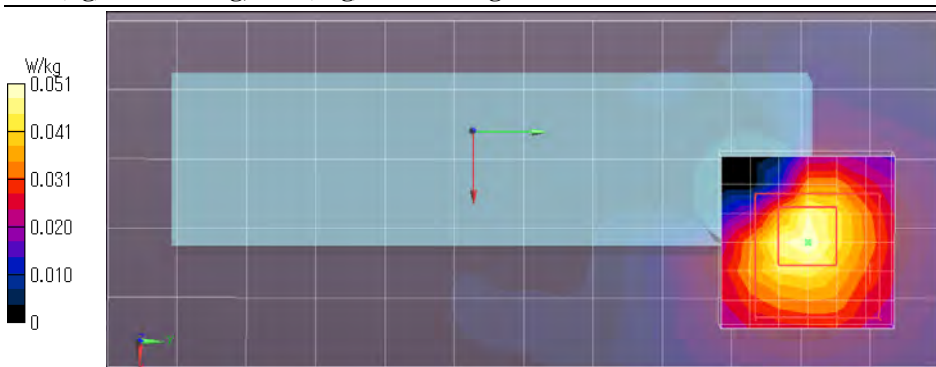

Remarks: *. Date tested: 2021/2/25; Tested by: Hiroshi Naka; Tested place: No.7 shielded room,
*. liquid depth: 150 mm; Position: distance of EUT to phantom: 0 mm (2 mm to liquid); ambient: (24~25) deg.C. / (35~50) %RH,
*. liquid temperature: 23.2(start)/23.2(end)/23.7(in check) deg.C.; *. White cubic: zoom scan area, Red cubic: big-SAR(10g) / small-SAR(1g)

Appendix 2: SAR measurement data / Appendix 2-4: Other SAR(1g) Plots (cont'd)**Plot 1-19: Rear (LCD side) & touch / 11b (1Mbps) / 2437MHz****EUT: Digital Camera; Type: R05010; Serial: 0000061****Mode: 11b(1Mbps, DBPSK/DSSS)** (UID: 0, Wi-fi_2.4GHz(0), Frame Length in ms: 0; PAR: 0; PMF: 1); **Frequency: 2437 MHz; Crest Factor: 1.0****Medium: HSL2450(2102); Medium parameters used: $f = 2437$ MHz; $\sigma = 1.866$ S/m; $\epsilon_r = 37.71$; $\rho = 1000$ kg/m³**

Measurement Standard: DASYS5 (IEEE/IEC/ANSI C63.19-2007)

DASY Configuration: -Electronics: DAE4 Sn626; Calibrated: 2020/11/17 / -Phantom: ELI v4.0; Type: QDOVA001BA; Serial: 1059; Phantom section: Flat Section

-DASY52 52.10.3(1513); SEMCAD X 14.6.13(7474) / -Probe: EX3DV4 - SN3907; ConvF(7.26, 7.26, 7.26) @ 2437 MHz; Calibrated: 2020/04/27

-Sensor-Surface: 2mm (Mechanical Surface Detection), z = 1.0

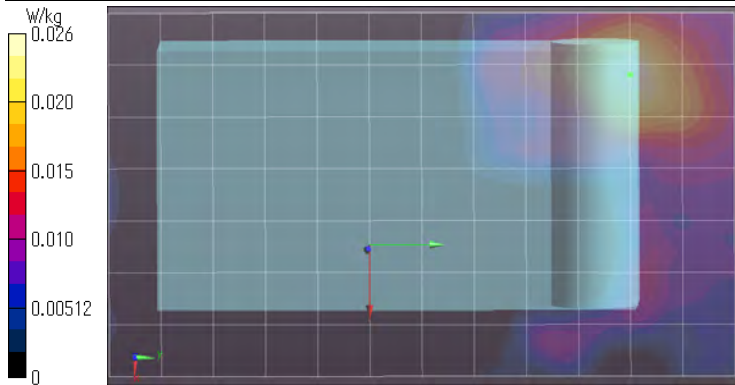
touch,h24,3/24h33;2437,rear&d0,b(1m)**Area:90x144,12 (8x13x1):** Measurement grid: dx=12mm, dy=12mm; Maximum value of SAR (measured) = 0.0251 W/kg**Area:90x144,12 (71x121x1):** Interpolated grid: dx=1.200 mm, dy=1.200 mm; Maximum value of SAR (interpolated) = 0.0256 W/kg

Remarks: * Date tested: 2021/2/25; Tested by: Hiroshi Naka; Tested place: No.7 shielded room,
 * liquid depth: 150 mm; Position: distance of EUT to phantom: 0 mm (2 mm to liquid); ambient: (24~25) deg.C. / (35~50) %RH,
 * liquid temperature: 23.2(start)/23.3(end)/23.7(in check) deg.C.; * White cubic: zoom scan area, Red cubic: big=SAR(10g)/small=SAR(1g)

Plot 1-20: Front-right(1) & touch / 11b (2Mbps) / 2437MHz**EUT: Digital Camera; Type: R05010; Serial: 0000061****Mode: 11b(2Mbps, DQPSK/DSSS)** (UID: 0, Wi-fi_2.4GHz(0), Frame Length in ms: 0; PAR: 0; PMF: 1); **Frequency: 2437 MHz; Crest Factor: 1.0****Medium: HSL2450(2102); Medium parameters used: $f = 2437$ MHz; $\sigma = 1.866$ S/m; $\epsilon_r = 37.71$; $\rho = 1000$ kg/m³**

Measurement Standard: DASYS5 (IEEE/IEC/ANSI C63.19-2007)

DASY Configuration: -Electronics: DAE4 Sn626; Calibrated: 2020/11/17 / -Phantom: ELI v4.0; Type: QDOVA001BA; Serial: 1059; Phantom section: Flat Section

-DASY52 52.10.3(1513); SEMCAD X 14.6.13(7474) / -Probe: EX3DV4 - SN3907; ConvF(7.26, 7.26, 7.26) @ 2437 MHz; Calibrated: 2020/04/27

-Sensor-Surface: 2mm (Mechanical Surface Detection (Locations From Previous Scan Used)), Sensor-Surface: 2mm (Mechanical Surface Detection), z = 1.0, 31.0

touch,h24,2/24h17;2437,Frt-R(1)&d0,b(2m)**Area:72x60,12 (7x6x1):** Measurement grid: dx=12mm, dy=12mm; Maximum value of SAR (measured) = 0.950 W/kg**Area:72x60,12 (61x51x1):** Interpolated grid: dx=1.200 mm, dy=1.200 mm; Maximum value of SAR (interpolated) = 1.52 W/kg**Zoom:30x30x30,5 (7x7x7)/Cube 0:** Measurement grid: dx=5mm, dy=5mm, dz=5mm;

Reference Value = 29.61 V/m; Power Drift = -0.01 dB; Maximum value of SAR (measured) = 1.57 W/kg; Peak SAR (extrapolated) = 2.40 W/kg

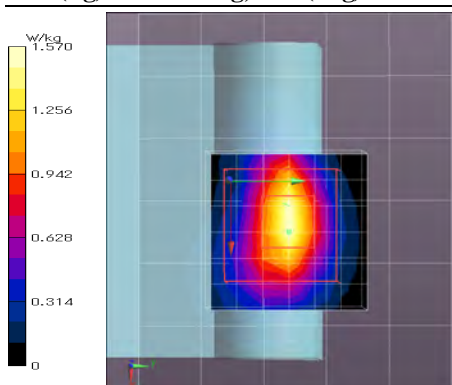
SAR(1 g) = 0.878 W/kg; SAR(10 g) = 0.324 W/kg (* Smallest distance from peaks to all points 3 dB below = 6 mm; Ratio of SAR at M2 to SAR at M1 = 39.3%)

Remarks: * Date tested: 2021/2/25; Tested by: Hiroshi Naka; Tested place: No.7 shielded room,
 * liquid depth: 150 mm; Position: distance of EUT to phantom: 0 mm (2 mm to liquid); ambient: (24~25) deg.C. / (35~50) %RH,
 * liquid temperature: 23.4(start)/23.4(end)/23.7(in check) deg.C.; * White cubic: zoom scan area, Red cubic: big=SAR(10g)/small=SAR(1g)

Appendix 2: SAR measurement data / Appendix 2-4: Other SAR(1g) Plots (cont'd)

Plot 1-21: Front-right(1) & touch / 11b (2Mbps) / 2462MHz

EUT: Digital Camera; Type: R05010; Serial: 0000061

Mode: 11b(2Mbps, DQPSK/DSSS) (UID: 0, Wi-fi_2.4GHz (0), Frame Length in ms: 0, PAR: 0, PMF: 1); **Frequency: 2462 MHz; Crest Factor: 1.0**

Medium: HSL2450(2102); Medium parameters used: f = 2462 MHz; $\sigma = 1.896$ S/m; $\epsilon_r = 37.63$; $\rho = 1000$ kg/m³

Measurement Standard: DASYS (IEEE/IEC/ANSI C63.19-2007)

DASY Configuration: -Electronics: DAE4 Sn626; Calibrated: 2020/11/17 / -Phantom: ELI v4.0; Type: QDOVA001BA; Serial: 1059; Phantom section: Flat Section

-DASY52 52.10.3(1513); SEMCAD X 14.6.13(7474) / -Probe: EX3DV4 - SN3907; ConvF(7.26, 7.26, 7.26) @ 2462 MHz; Calibrated: 2020/04/27

-Sensor-Surface: 2mm (Mechanical Surface Detection (Locations From Previous Scan Used)), Sensor-Surface: 2mm (Mechanical Surface Detection), z = 1.0, 31.0, 161.0

touch,h24,o24h12;2462,Frt-R(1)&d0,b(2m)

Area:72x60,12 (7x6x1): Measurement grid: dx=12mm, dy=12mm; Maximum value of SAR (measured) = 1.08 W/kg

Area:72x60,12 (61x51x1): Interpolated grid: dx=1.200 mm, dy=1.200 mm; Maximum value of SAR (interpolated) = 1.71 W/kg

Z;160,5 (1x1x33): Measurement grid: dx=20mm, dy=20mm, dz=5mm; Maximum value of SAR (measured) = 1.73 W/kg

Zoom:30x30x30,5 (7x7x7)/Cube 0: Measurement grid: dx=5mm, dy=5mm, dz=5mm;

Reference Value = 30.95 V/m; Power Drift = 0.00 dB; Maximum value of SAR (measured) = 1.74 W/kg; Peak SAR (extrapolated) = 2.67 W/kg

SAR(1 g) = 0.971 W/kg; SAR(10 g) = 0.357 W/kg (*. Smallest distance from peaks to all points 3 dB below = 6 mm; Ratio of SAR at M2 to SAR at M1 = 37.8%)

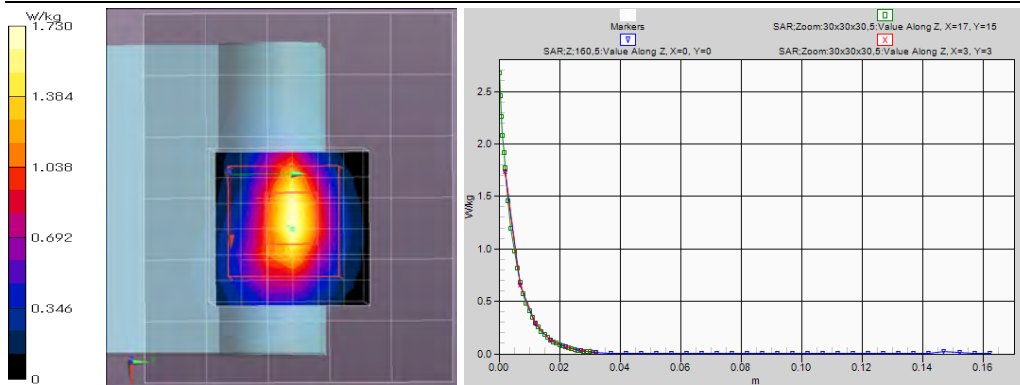

Remarks: * Date tested: 2021/2/24; Tested by: Hiroshi Naka; Tested place: No.7 shielded room,
 * liquid depth: 150 mm; Position: distance of EUT to phantom: 0 mm (2 mm to liquid); ambient: (24~25) deg.C. / (35~50) %RH,
 * liquid temperature: 23.3(start)/23.3(end)/23.7(in check) deg.C.; *.White cubic: zoom scan area, Red cubic: big=SAR(10g) /small=SAR(1g)

Plot 1-22: (USB power operation, with battery) Front-right(1) & touch / 11b (2Mbps) / 2462MHz

EUT: Digital Camera; Type: R05010; Serial: 0000061

Mode: 11b(2Mbps, DQPSK/DSSS) (UID: 0, Wi-fi_2.4GHz (0), Frame Length in ms: 0, PAR: 0, PMF: 1); **Frequency: 2462 MHz; Crest Factor: 1.0**

Medium: HSL2450(2102); Medium parameters used: f = 2462 MHz; $\sigma = 1.896$ S/m; $\epsilon_r = 37.63$; $\rho = 1000$ kg/m³

Measurement Standard: DASYS (IEEE/IEC/ANSI C63.19-2007)

DASY Configuration: -Electronics: DAE4 Sn626; Calibrated: 2020/11/17 / -Phantom: ELI v4.0; Type: QDOVA001BA; Serial: 1059; Phantom section: Flat Section

-DASY52 52.10.3(1513); SEMCAD X 14.6.13(7474) / -Probe: EX3DV4 - SN3907; ConvF(7.26, 7.26, 7.26) @ 2462 MHz; Calibrated: 2020/04/27

-Sensor-Surface: 2mm (Mechanical Surface Detection), z = 1.0, 31.0, 161.0

touch,h24,224h41b;2462,Frt-R(1)&d0,b(2m),usb/

Area:72x60,12 (7x6x1): Measurement grid: dx=12mm, dy=12mm; Maximum value of SAR (measured) = 0.840 W/kg

Area:72x60,12 (61x51x1): Interpolated grid: dx=1.200 mm, dy=1.200 mm; Maximum value of SAR (interpolated) = 1.72 W/kg

Z;160,5 (1x1x33): Measurement grid: dx=20mm, dy=20mm, dz=5mm; Maximum value of SAR (measured) = 1.75 W/kg

Zoom:30x30x30,5 (7x7x7)/Cube 0: Measurement grid: dx=5mm, dy=5mm, dz=5mm;

Reference Value = 29.67 V/m; Power Drift = 0.20 dB; Maximum value of SAR (measured) = 1.77 W/kg; Peak SAR (extrapolated) = 2.71 W/kg

SAR(1 g) = 0.972 W/kg; SAR(10 g) = 0.350 W/kg (*. Smallest distance from peaks to all points 3 dB below = 6 mm; Ratio of SAR at M2 to SAR at M1 = 38.1%)

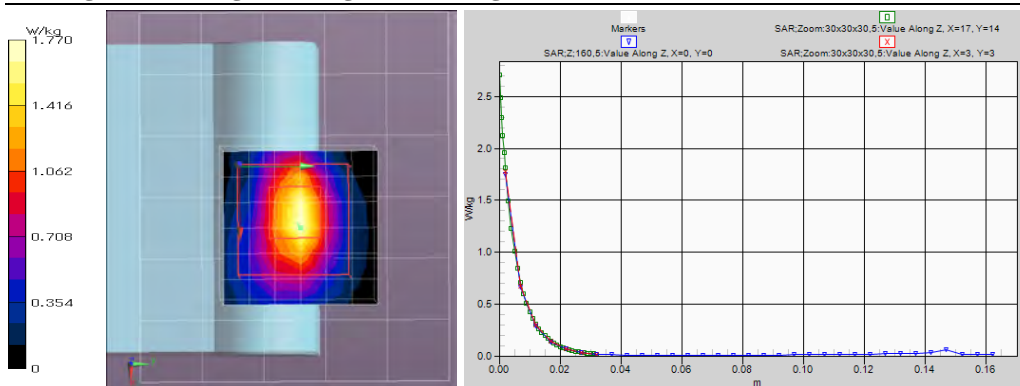

Remarks: * Date tested: 2021/2/25; Tested by: Hiroshi Naka; Tested place: No.7 shielded room,
 * liquid depth: 150 mm; Position: distance of EUT to phantom: 0 mm (2 mm to liquid); ambient: (24~25) deg.C. / (35~50) %RH,
 * liquid temperature: 23.4(start)/23.3(end)/23.7(in check) deg.C.; *.White cubic: zoom scan area, Red cubic: big=SAR(10g) /small=SAR(1g)

Appendix 2: SAR measurement data / Appendix 2-4: Other SAR(1g) Plots (cont'd)

Plot 1-23: Front-right(1) & touch / 11b (2Mbps) / 2412MHz

EUT: Digital Camera; Type: R05010; Serial: 0000061

Mode: 11b(2Mbps, DQPSK/DSSS) (UID: 0, Wi-fi_2.4GHz (0), Frame Length in ms: 0; PAR: 0; PMF: 1); **Frequency: 2412 MHz; Crest Factor: 1.0**

Medium: HSL2450(2102); Medium parameters used: f = 2412 MHz; $\sigma = 1.837$ S/m; $\epsilon_r = 37.82$; $\rho = 1000$ kg/m³

Measurement Standard: DASYS5 (IEEE/IEC/ANSI C63.19-2007)

DASY Configuration: -Electronics: DAE4 Sn626; Calibrated: 2020/11/17 / -Phantom: ELI v4.0; Type: QDOVA001BA; Serial: 1059; Phantom section: Flat Section

-DASY52 52.10.3(1513); SEMCAD X 14.6.13(7474) / -Probe: EX3DV4 - SN3907; ConvF(7.26, 7.26, 7.26) @ 2412 MHz; Calibrated: 2020/04/27

-Sensor-Surface: 2mm (Mechanical Surface Detection (Locations From Previous Scan Used)), Sensor-Surface: 2mm (Mechanical Surface Detection), z = 1.0, 31.0

touch,h24,2/24h18;2412,Frt-R(1)&d0,b(2m)/

Area:72x60,12 (7x6x1): Measurement grid: dx=12mm, dy=12mm; Maximum value of SAR (measured) = 0.903 W/kg

Area:72x60,12 (61x51x1): Interpolated grid: dx=1.200 mm, dy=1.200 mm; Maximum value of SAR (interpolated) = 1.42 W/kg

Zoom:30x30x30,5 (7x7x7)/Cube 0: Measurement grid: dx=5mm, dy=5mm, dz=5mm;

Reference Value = 29.17 V/m; Power Drift = -0.00 dB; Maximum value of SAR (measured) = 1.49 W/kg; Peak SAR (extrapolated) = 2.28 W/kg

SAR(1 g) = 0.838 W/kg; SAR(10 g) = 0.310 W/kg (*. Smallest distance from peaks to all points 3 dB below = 6 mm; Ratio of SAR at M2 to SAR at M1 = 38.6%)

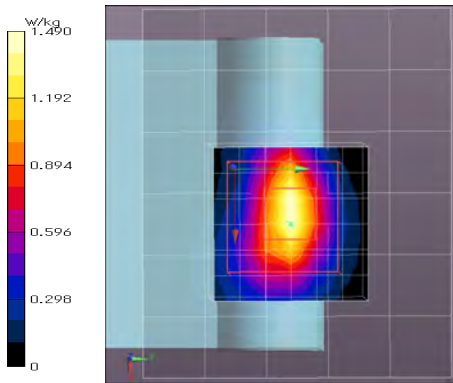

Remarks: * Date tested: 2021/2/25; Tested by: Hiroshi Naka; Tested place: No.7 shielded room,
 * liquid depth: 150 mm; Position: distance of EUT to phantom: 0 mm (2 mm to liquid); ambient: (24~25) deg.C. / (35~50) %RH,
 * liquid temperature: 23.4(start)/23.4(end)/23.7(in check) deg.C.; *.White cubic: zoom scan area, Red cubic: big=SAR(10g)/small=SAR(1g)

Plot 1-24: Front-right(1) & touch / 11g (6Mbps) / 2437MHz

EUT: Digital Camera; Type: R05010; Serial: 0000061

Mode: 11g(6Mbps, BPSK/OFDM) (UID: 0, Wi-fi_2.4GHz (0), Frame Length in ms: 0; PAR: 0; PMF: 1); **Frequency: 2437 MHz; Crest Factor: 1.0**

Medium: HSL2450(2102); Medium parameters used: f = 2437 MHz; $\sigma = 1.866$ S/m; $\epsilon_r = 37.71$; $\rho = 1000$ kg/m³

Measurement Standard: DASYS5 (IEEE/IEC/ANSI C63.19-2007)

DASY Configuration: -Electronics: DAE4 Sn626; Calibrated: 2020/11/17 / -Phantom: ELI v4.0; Type: QDOVA001BA; Serial: 1059; Phantom section: Flat Section

-DASY52 52.10.3(1513); SEMCAD X 14.6.13(7474) / -Probe: EX3DV4 - SN3907; ConvF(7.26, 7.26, 7.26) @ 2437 MHz; Calibrated: 2020/04/27

-Sensor-Surface: 2mm (Mechanical Surface Detection (Locations From Previous Scan Used)), Sensor-Surface: 2mm (Mechanical Surface Detection), z = 1.0, 31.0

touch,h24,2/24h15;2437,Frt-R(1)&d0,g(6m)/

Area:72x60,12 (7x6x1): Measurement grid: dx=12mm, dy=12mm; Maximum value of SAR (measured) = 1.14 W/kg

Area:72x60,12 (61x51x1): Interpolated grid: dx=1.200 mm, dy=1.200 mm; Maximum value of SAR (interpolated) = 1.79 W/kg

Zoom:30x30x30,5 (7x7x7)/Cube 0: Measurement grid: dx=5mm, dy=5mm, dz=5mm;

Reference Value = 32.23 V/m; Power Drift = 0.01 dB; Maximum value of SAR (measured) = 1.84 W/kg; Peak SAR (extrapolated) = 2.87 W/kg

SAR(1 g) = 1.05 W/kg; SAR(10 g) = 0.384 W/kg (*. Smallest distance from peaks to all points 3 dB below = 6 mm; Ratio of SAR at M2 to SAR at M1 = 38.6%)

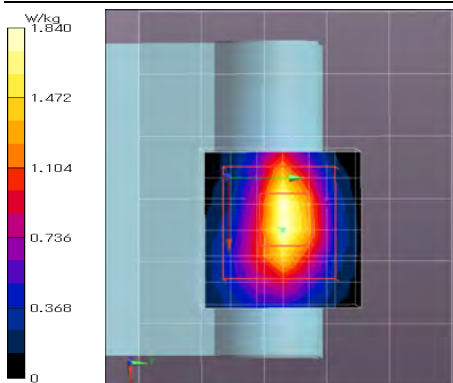

Remarks: * Date tested: 2021/2/25; Tested by: Hiroshi Naka; Tested place: No.7 shielded room,
 * liquid depth: 150 mm; Position: distance of EUT to phantom: 0 mm (2 mm to liquid); ambient: (24~25) deg.C. / (35~50) %RH,
 * liquid temperature: 23.5(start)/23.4(end)/23.7(in check) deg.C.; *.White cubic: zoom scan area, Red cubic: big=SAR(10g)/small=SAR(1g)

Appendix 2: SAR measurement data / Appendix 2-4: Other SAR(1g) Plots (cont'd)**Plot 1-25: Front-right(1) & touch / 11g (6Mbps) / 2462MHz****EUT: Digital Camera; Type: R05010; Serial: 0000061****Mode: 11g(6Mbps, BPSK/OFDM)** (UID: 0, Wi-fi_2.4GHz (0), Frame Length in ms: 0; PAR: 0; PMF: 1); **Frequency: 2462 MHz; Crest Factor: 1.0****Medium: HSL2450(2102); Medium parameters used: f = 2462 MHz; $\sigma = 1.896$ S/m; $\epsilon_r = 37.63$; $\rho = 1000$ kg/m³**

Measurement Standard: DASY5 (IEEE/IEC/ANSI C63.19-2007)

DASY Configuration: -Electronics: DAE4 Sn626; Calibrated: 2020/11/17 / -Phantom: ELI v4.0; Type: QDOVA001BA; Serial: 1059; Phantom section: Flat Section

-DASY52 52.10.3(1513); SEMCAD X 14.6.13(7474) / -Probe: EX3DV4 - SN3907; ConvF(7.26, 7.26, 7.26) @ 2462 MHz; Calibrated: 2020/04/27

-Sensor-Surface: 2mm (Mechanical Surface Detection (Locations From Previous Scan Used)), Sensor-Surface: 2mm (Mechanical Surface Detection), z = 1.0, 31.0

touch,h24/24h10;2462,Frt-R(1)&d0,g(6m)**Area:72x60,12 (7x6x1):** Measurement grid: dx=12mm, dy=12mm; Maximum value of SAR (measured) = 1.23 W/kg**Area:72x60,12 (61x51x1):** Interpolated grid: dx=1.200 mm, dy=1.200 mm; Maximum value of SAR (interpolated) = 1.91 W/kg**Zoom:30x30x30,5 (7x7x7)/Cube 0:** Measurement grid: dx=5mm, dy=5mm, dz=5mm;

Reference Value = 32.83 V/m; Power Drift = -0.01 dB; Maximum value of SAR (measured) = 1.97 W/kg; Peak SAR (extrapolated) = 3.03 W/kg

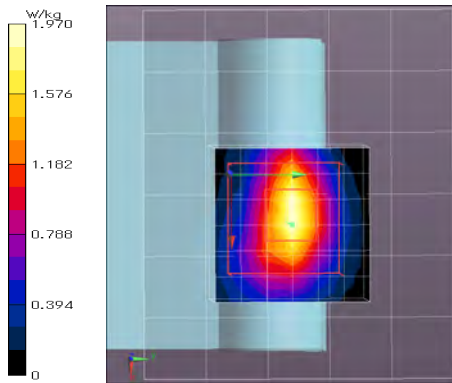
SAR(1 g) = 1.1 W/kg; SAR(10 g) = 0.403 W/kg (*: Smallest distance from peaks to all points 3 dB below = 6 mm; Ratio of SAR at M2 to SAR at M1 = 37.6%)

Remarks: * Date tested: 2021/2/24; Tested by: Hiroshi Naka; Tested place: No.7 shielded room,
 * liquid depth: 150 mm; Position: distance of EUT to phantom: 0 mm (2 mm to liquid); ambient: (24~25) deg.C. / (35~50) %RH,
 * liquid temperature: 23.4(start)/23.4(end)/23.7(in check) deg.C.; * White cubic: zoom scan area, Red cubic: big-SAR(10g) / small-SAR(1g)

Plot 1-26: Front-right(1) & touch / 11g (6Mbps) / 2412MHz**EUT: Digital Camera; Type: R05010; Serial: 0000061****Mode: 11g(6Mbps, BPSK/OFDM)** (UID: 0, Wi-fi_2.4GHz (0), Frame Length in ms: 0; PAR: 0; PMF: 1); **Frequency: 2412 MHz; Crest Factor: 1.0****Medium: HSL2450(2102); Medium parameters used: f = 2412 MHz; $\sigma = 1.837$ S/m; $\epsilon_r = 37.82$; $\rho = 1000$ kg/m³**

Measurement Standard: DASY5 (IEEE/IEC/ANSI C63.19-2007)

DASY Configuration: -Electronics: DAE4 Sn626; Calibrated: 2020/11/17 / -Phantom: ELI v4.0; Type: QDOVA001BA; Serial: 1059; Phantom section: Flat Section

-DASY52 52.10.3(1513); SEMCAD X 14.6.13(7474) / -Probe: EX3DV4 - SN3907; ConvF(7.26, 7.26, 7.26) @ 2412 MHz; Calibrated: 2020/04/27

-Sensor-Surface: 2mm (Mechanical Surface Detection (Locations From Previous Scan Used)), Sensor-Surface: 2mm (Mechanical Surface Detection), z = 1.0, 31.0

touch,h24/24h16;2412,Frt-R(1)&d0,g(6m)**Area:72x60,12 (7x6x1):** Measurement grid: dx=12mm, dy=12mm; Maximum value of SAR (measured) = 1.02 W/kg**Area:72x60,12 (61x51x1):** Interpolated grid: dx=1.200 mm, dy=1.200 mm; Maximum value of SAR (interpolated) = 1.56 W/kg**Zoom:30x30x30,5 (7x7x7)/Cube 0:** Measurement grid: dx=5mm, dy=5mm, dz=5mm;

Reference Value = 31.90 V/m; Power Drift = 0.02 dB; Maximum value of SAR (measured) = 1.81 W/kg; Peak SAR (extrapolated) = 2.81 W/kg

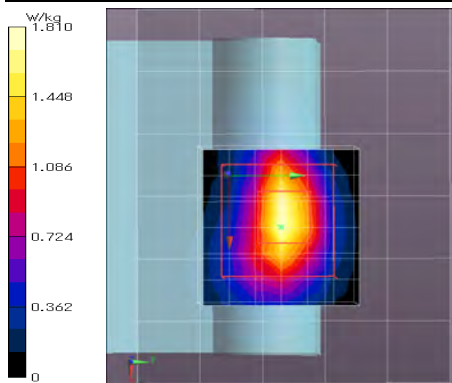
SAR(1 g) = 1.03 W/kg; SAR(10 g) = 0.377 W/kg (*: Smallest distance from peaks to all points 3 dB below = 6 mm; Ratio of SAR at M2 to SAR at M1 = 38.9%)

Remarks: * Date tested: 2021/2/25; Tested by: Hiroshi Naka; Tested place: No.7 shielded room,
 * liquid depth: 150 mm; Position: distance of EUT to phantom: 0 mm (2 mm to liquid); ambient: (24~25) deg.C. / (35~50) %RH,
 * liquid temperature: 23.4(start)/23.4(end)/23.7(in check) deg.C.; * White cubic: zoom scan area, Red cubic: big-SAR(10g) / small-SAR(1g)

Appendix 2: SAR measurement data / Appendix 2-4: Other SAR(1g) Plots (cont'd)**Plot 1-27: Front-right(1) & touch / 11n(20HT)(MCS0) / 2437MHz****EUT: Digital Camera; Type: R05010; Serial: 0000061****Mode: n20(MCS0, BPSK/OFDM)** (UID: 0, Wi-fi_2.4GHz (0), Frame Length in ms: 0, PAR: 0, PMF: 1); **Frequency: 2437 MHz; Crest Factor: 1.0****Medium: HSL2450(2102); Medium parameters used: f = 2437 MHz; $\sigma = 1.866$ S/m; $\epsilon_r = 37.71$; $\rho = 1000$ kg/m³**

Measurement Standard: DASY5 (IEEE/IEC/ANSI C63.19-2007)

DASY Configuration: -Electronics: DAE4 Sn626; Calibrated: 2020/11/17 / -Phantom: ELI v4.0; Type: QDOVA001BA; Serial: 1059; Phantom section: Flat Section

-DASY52 52.10.3(1513); SEMCAD X 14.6.13(7474) / -Probe: EX3DV4 - SN3907; ConvF(7.26, 7.26, 7.26) @ 2437 MHz; Calibrated: 2020/04/27

-Sensor-Surface: 2mm (Mechanical Surface Detection (Locations From Previous Scan Used)), Sensor-Surface: 2mm (Mechanical Surface Detection), z = 1.0, 31.0

touch,h24,2/24h19;2437,Frt-R(1)&d0,n20(m0)/**Area:72x60,12 (7x6x1):** Measurement grid: dx=12mm, dy=12mm; Maximum value of SAR (measured) = 1.09 W/kg**Area:72x60,12 (61x51x1):** Interpolated grid: dx=1.200 mm, dy=1.200 mm; Maximum value of SAR (interpolated) = 1.53 W/kg**Zoom:30x30x30,5 (7x7x7)/Cube 0:** Measurement grid: dx=5mm, dy=5mm, dz=5mm;

Reference Value = 30.03 V/m; Power Drift = -0.10 dB; Maximum value of SAR (measured) = 1.60 W/kg; Peak SAR (extrapolated) = 2.45 W/kg

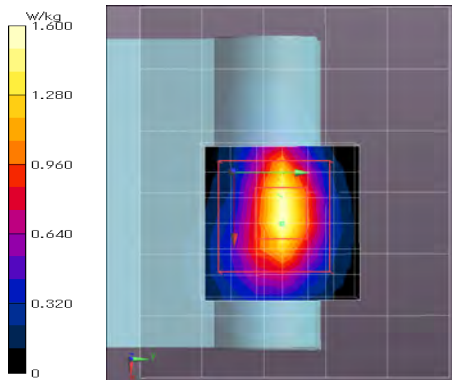
SAR(1 g) = 0.891 W/kg; SAR(10 g) = 0.327 W/kg (*. Smallest distance from peaks to all points 3 dB below = 5.8 mm; Ratio of SAR at M2 to SAR at M1 = 38.8%)

Remarks: * Date tested: 2021/2/25; Tested by: Hiroshi Naka; Tested place: No.7 shielded room,
 * liquid depth: 150 mm; Position: distance of EUT to phantom: 0 mm (2 mm to liquid); ambient: (24~25) deg.C. / (35~50) %RH,
 * liquid temperature: 23.4(start)/23.4(end)/23.7(in check) deg.C.; *.White cubic: zoom scan area, Red cubic: big=SAR(10g)/small=SAR(1g)

Plot 1-28: Front-right(1) & touch / 11n(20HT)(MCS0) / 2462MHz**EUT: Digital Camera; Type: R05010; Serial: 0000061****Mode: n20(MCS0, BPSK/OFDM)** (UID: 0, Wi-fi_2.4GHz (0), Frame Length in ms: 0, PAR: 0, PMF: 1); **Frequency: 2462 MHz; Crest Factor: 1.0****Medium: HSL2450(2102); Medium parameters used: f = 2462 MHz; $\sigma = 1.896$ S/m; $\epsilon_r = 37.63$; $\rho = 1000$ kg/m³**

Measurement Standard: DASY5 (IEEE/IEC/ANSI C63.19-2007)

DASY Configuration: -Electronics: DAE4 Sn626; Calibrated: 2020/11/17 / -Phantom: ELI v4.0; Type: QDOVA001BA; Serial: 1059; Phantom section: Flat Section

-DASY52 52.10.3(1513); SEMCAD X 14.6.13(7474) / -Probe: EX3DV4 - SN3907; ConvF(7.26, 7.26, 7.26) @ 2462 MHz; Calibrated: 2020/04/27

-Sensor-Surface: 2mm (Mechanical Surface Detection (Locations From Previous Scan Used)), Sensor-Surface: 2mm (Mechanical Surface Detection), z = 1.0, 31.0

touch,h24/24h11;2462,Frt-R(1)&d0,n20(m0)/**Area:72x60,12 (7x6x1):** Measurement grid: dx=12mm, dy=12mm; Maximum value of SAR (measured) = 1.04 W/kg**Area:72x60,12 (61x51x1):** Interpolated grid: dx=1.200 mm, dy=1.200 mm; Maximum value of SAR (interpolated) = 1.63 W/kg**Zoom:30x30x30,5 (7x7x7)/Cube 0:** Measurement grid: dx=5mm, dy=5mm, dz=5mm;

Reference Value = 30.03 V/m; Power Drift = 0.01 dB; Maximum value of SAR (measured) = 1.67 W/kg; Peak SAR (extrapolated) = 2.56 W/kg

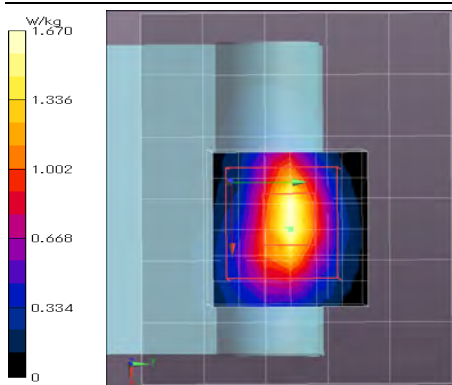
SAR(1 g) = 0.929 W/kg; SAR(10 g) = 0.342 W/kg (*. Smallest distance from peaks to all points 3 dB below = 6 mm; Ratio of SAR at M2 to SAR at M1 = 37.8%)

Remarks: * Date tested: 2021/2/24; Tested by: Hiroshi Naka; Tested place: No.7 shielded room,
 * liquid depth: 150 mm; Position: distance of EUT to phantom: 0 mm (2 mm to liquid); ambient: (24~25) deg.C. / (35~50) %RH,
 * liquid temperature: 23.4(start)/23.4(end)/23.7(in check) deg.C.; *.White cubic: zoom scan area, Red cubic: big=SAR(10g)/small=SAR(1g)

UL Japan, Inc.**Shonan EMC Lab.**

1-22-3 Megumigaoka, Hiratsuka-shi, Kanagawa-ken, 259-1220 JAPAN

Telephone: +81 463 50 6400 / Facsimile: +81 463 50 6401

Report Cover Page - 13-EM-F0429 Issue # 19.0

Appendix 2: SAR measurement data / Appendix 2-4: Other SAR(1g) Plots (cont'd)

Plot 1-29: Front-right(1) & touch / 11n(20HT)(MCS0) / 2412MHz

EUT: Digital Camera; Type: R05010; Serial: 0000061

Mode: n20(MCS0, BPSK/OFDM) (UID: 0, Wi-fi_2.4GHz (0), Frame Length in ms: 0, PAR: 0, PMF: 1); **Frequency: 2412 MHz; Crest Factor: 1.0**

Medium: HSL2450(2102); Medium parameters used: f = 2412 MHz; $\sigma = 1.837$ S/m; $\epsilon_r = 37.82$; $\rho = 1000$ kg/m³

Measurement Standard: DASY5 (IEEE/IEC/ANSI C63.19-2007)

DASY Configuration: -Electronics: DAE4 Sn626; Calibrated: 2020/11/17 / -Phantom: ELI v4.0; Type: QDOVA001BA; Serial: 1059; Phantom section: Flat Section

-DASY52 52.10.3(1513); SEMCAD X 14.6.13(7474) / -Probe: EX3DV4 - SN3907; ConvF(7.26, 7.26, 7.26) @ 2412 MHz; Calibrated: 2020/04/27

-Sensor-Surface: 2mm (Mechanical Surface Detection (Locations From Previous Scan Used)), Sensor-Surface: 2mm (Mechanical Surface Detection), z = 1.0, 31.0

touch,h24,224h20;2412,Frt-R(1)&d0,n20(m0)/

Area:72x60,12 (7x6x1): Measurement grid: dx=12mm, dy=12mm; Maximum value of SAR (measured) = 1.00 W/kg

Area:72x60,12 (61x51x1): Interpolated grid: dx=1.200 mm, dy=1.200 mm; Maximum value of SAR (interpolated) = 1.42 W/kg

Zoom:30x30x30,5 (7x7x7)/Cube 0: Measurement grid: dx=5mm, dy=5mm, dz=5mm;

Reference Value = 29.27 V/m; Power Drift = -0.01 dB; Maximum value of SAR (measured) = 1.52 W/kg; Peak SAR (extrapolated) = 2.31 W/kg

SAR(1 g) = 0.848 W/kg; SAR(10 g) = 0.312 W/kg (*. Smallest distance from peaks to all points 3 dB below = 5.8 mm; Ratio of SAR at M2 to SAR at M1 = 39.1%)

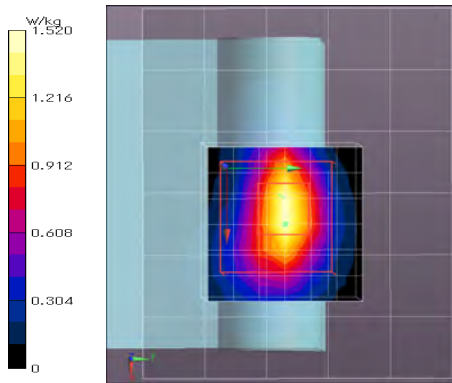

Remarks: * Date tested: 2021/2/25; Tested by: Hiroshi Naka; Tested place: No.7 shielded room.
 * liquid depth: 150 mm; Position: distance of EUT to phantom: 0 mm (2 mm to liquid); ambient: (24~25) deg.C. / (35~50) %RH,
 * liquid temperature: 23.4(start)/23.4(end)/23.7(in check) deg.C.; *.White cubic: zoom scan area, Red cubic: big=SAR(10g)/small=SAR(1g)

APPENDIX 3: Test instruments**Appendix 3-1: Equipment used**

| Test Name | Local ID | LIMS ID | Description | Manufacturer | Model | Serial | Calibration | |
|-----------|---------------|---------|---|-----------------------------------|---------------------------------|--------------------|-------------|------------------|
| | | | | | | | Last Date | Interval (Month) |
| AT | KAT10-S3 | 144893 | Attenuator | Keysight Technologies Inc | 8490D 010 | 50924 | 2020/12/11 | 12 |
| AT | KSA-08 | 145089 | Spectrum Analyzer | Keysight Technologies Inc | E4446A | MY46180525 | 2020/11/30 | 12 |
| AT | SPM-13 | 169910 | Power Meter | Keysight Technologies Inc | 8990B | MY51000448 | 2021/1/25 | 12 |
| AT | SPSS-06 | 169911 | Power sensor | Keysight Technologies Inc | N1923A | MY57270004 | 2021/1/25 | 12 |
| AT.SAR | SOS-26 | 191844 | Humidity Indicator | CUSTOM. Inc | CTH-201 | - | 2020/09/30 | 12 |
| SAR | COTS-SSAR-02 | 144885 | DASY52 software | Schmid&Partner Engineering AG | DASY5 PRO | Ver.52.10.3.1513 | - | - |
| SAR | COTS-SSSEP-02 | 144886 | Dielectric assessment software | Schmid&Partner Engineering AG | DAK | Ver.DAK1.10.317.11 | - | - |
| SAR | KAT10-P1 | 144882 | Attenuator | Weinschel - API Technologies Corp | 24-10-34 | BY5927 | 2020/12/11 | 12 |
| SAR | KCPL-07 | 146100 | Directional Coupler | Pulsar Microwave Corp. | CCS30-B26 | 621 | - | - |
| SAR | KDAE-01 | 144944 | Data Acquisition Electronics | Schmid&Partner Engineering AG | DAE4 | 626 | 2020/11/17 | 12 |
| SAR | KIU-08 | 145059 | Power sensor | Rohde & Schwarz | NRV-Z4 | 100372 | 2020/09/15 | 12 |
| SAR | KIU-09 | 145099 | Power sensor | Rohde & Schwarz | NRV-Z4 | 100371 | 2020/09/15 | 12 |
| SAR | KOS-14 | 144986 | Thermo-Hygrometer data logger | SATO KEIRYOKI | SK-L200THIIα/SK-LTHIIα-2 | 015246/08169 | 2020/10/01 | 12 |
| SAR | KPA-12 | 145359 | RF Power Amplifier | Milmega | AS2560-50 | 1018582 | - | - |
| SAR | KPFL-01 | 145560 | Flat Phantom | Schmid&Partner Engineering AG | Oval flat phantom ELI 4.0 | 1059 | 2020/08/19 | 12 |
| SAR | KPM-05 | 144988 | Power meter | Keysight Technologies Inc | E4417A | GB41290718 | 2020/04/17 | 12 |
| SAR | KPM-06 | 144989 | Power Meter | Rohde & Schwarz | NRVD | 101599 | 2020/09/15 | 12 |
| SAR | KPSS-01 | 144990 | Power sensor | Keysight Technologies Inc | E9327A | US40440544 | 2020/04/17 | 12 |
| SAR | KRU-01 | 144993 | Ruler(300mm) | SHINWA | 13134 | - | 2021/2/10 | 12 |
| SAR | KRU-05 | 145087 | Ruler(100x50mm.L) | SHINWA | 12103 | - | 2021/2/10 | 12 |
| SAR | KSDA-01 | 145090 | Dipole Antenna | Schmid&Partner Engineering AG | D2450V2 | 822 | 2020/11/10 | 12 |
| SAR | KSDH-01 | 145596 | Device holder | Schmid&Partner Engineering AG | Mounting device for transmitter | - | 2020/09/03 | 12 |
| SAR | KSG-08 | 145109 | Signal Generator | Rohde & Schwarz | SMT06 | 100763 | 2020/09/14 | 12 |
| SAR | KSLH245-01 | 145363 | Tissue simulation liquid (2450MHz head) | Schmid&Partner Engineering AG | HSL2450V2 | SL AAH 245 BA | - | - |
| SAR | SALC-01 | 146112 | Primepure Ethanol | Kanto Chemical Co., Inc. | 14032-79 | - | - | - |
| SAR | SAT20-SARP1 | 160521 | Attenuator | Weinschel - API Technologies Corp | 4M-20 | - | 2020/12/11 | 12 |
| SAR | SCC-SAR2 | 145405 | Coaxial Cable | Huber+Suhrner | SF104A/11PC3542/11N451/4M | MY699/4A | 2020/12/11 | 12 |
| SAR | SEPP-02 | 145500 | Dielectric probe | Schmid&Partner Engineering AG | DAK3.5 | 1129 | 2020/08/12 | 12 |
| SAR | SOS-SAR2 | 201967 | Digital thermomoter | HANNA | Checktemp-4 | A01440226111 | 2020/10/02 | 12 |
| SAR | SOS-SAR3 | 201968 | Digital thermomoter | HANNA | Checktemp-4 | A01310946111 | 2020/10/02 | 12 |
| SAR | SPB-02 | 146235 | Dosimetric E-Field Probe | Schmid&Partner Engineering AG | EX3DV4 | 3907 | 2020/04/27 | 12 |
| SAR | SRU-06 | 150560 | Measuring Tool. Ruler | SHINWA | 14001 | -- | 2021/2/10 | 12 |
| SAR | SSA-04 | 146176 | Spectrum Analyzer | ADVANTEST | R3272 | 101100994 | - | - |
| SAR | SSAR-02 | 146177 | SAR measurement system | Schmid&Partner Engineering AG | DASY5 | 1324 | - | - |
| SAR | SSNA-01 | 146258 | Network Analyzer | Keysight Technologies Inc | 8753ES | US39171777 | 2020/11/09 | 12 |
| SAR | SSRBT-02 | 145621 | SAR robot | Schmid&Partner Engineering AG | TX60 Lspeag | F12/5L2QA1/A/01 | 2020/09/03 | 12 |
| SAR | SWTR-03 | 146185 | DI water | MonotaRo | 34557433 | - | - | - |

*. AT (antenna terminal conducted power measurement) was measured February 16, 2021. (Refer to Section 6 in this report.)

*. The parameters of primepure Ethanol (as reference liquid) used for the simulated tissue parameter confirmation was defined the NPL Report MAT23 (<http://www.npl.co.uk/content/conpublication/4295>)

The expiration date of calibration is the end of the expired month.

As for some calibrations performed after the tested dates, those test equipment have been controlled by means of an unbroken chain of calibrations.

All equipment is calibrated with valid calibrations. Each measurement data is traceable to the national or international standards.

*. Hyphens for Last Calibration Date and Cal Int (month) are instruments that Calibration is not required (e.g. software), or instruments checked in advance before use.

[Test Item] SAR: Specific Absorption Rate, AT: Antenna terminal conducted power

Appendix 3-2: Configuration and peripherals

These measurements were performed with the automated near-field scanning system DASY5 from Schmid & Partner Engineering AG (SPEAG). The system is based on a high precision robot, which positions the probes with a positional repeatability of better than ± 0.02 mm. Special E- and H-field probes have been developed for measurements close to material discontinuity, the sensors of which are directly loaded with a Schottky diode and connected via highly resistive lines to the data acquisition unit. The SAR measurements were conducted with the dosimetry probes EX3DV4 (manufactured by SPEAG), designed in the classical triangular configuration and optimized for dosimetric evaluation.

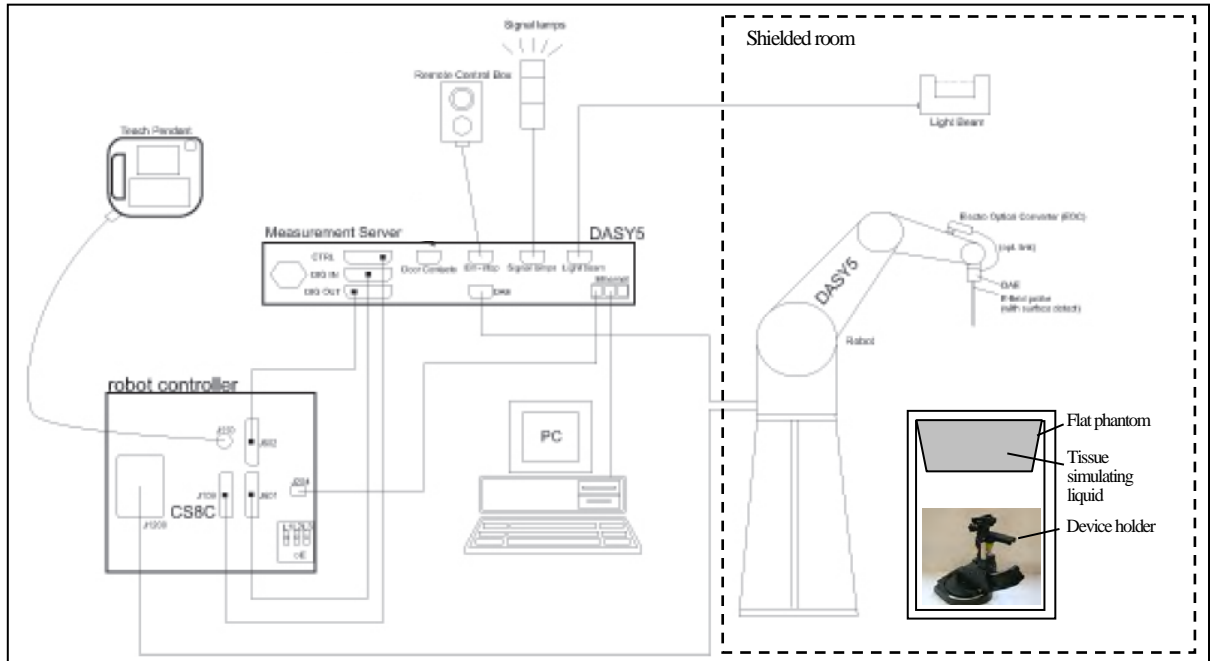

The DASY5 system for performing compliance tests consist of the following items:

| | |
|----|---|
| 1 | A standard high precision 6-axis robot (Stäubli TX/RX family) with controller, teach pendant and software. An arm extension for accommodating the data acquisition electronics (DAE). |
| 2 | An isotropic field probe optimized and calibrated for the targeted measurement. |
| 3 | A data acquisition electronics (DAE) which performs the signal amplification, signal multiplexing, AD-conversion, offset measurements, mechanical surface detection, collision detection, etc. The unit is battery powered with standard or rechargeable batteries. The signal is optically transmitted to the EOC. |
| 4 | The Electro-optical converter (EOC) performs the conversion from optical to electrical signals for the digital communication to the DAE. To use optical surface detection, a special version of the EOC is required. The EOC signal is transmitted to the measurement server. |
| 5 | The function of the measurement server is to perform the time critical tasks such as signal filtering, control of the robot operation and fast movement interrupts. |
| 6 | The Light Beam used is for probe alignment. This improves the (absolute) accuracy of the probe positioning. |
| 7 | A computer running Win7 professional operating system and the DASY5 software. |
| 8 | R Remote control and teach pendant as well as additional circuitry for robot safety such as warning lamps, etc. |
| 9 | The phantom. |
| 10 | The device holder for EUT. (low-loss dielectric palette) (*. when it was used.) |
| 11 | Tissue simulating liquid mixed according to the given recipes. |
| 12 | Validation dipole kits allowing to validate the proper functioning of the system. |

Appendix 3-3: Test system specification

TX60 Lsepag robot/CS8Csepag-TX60 robot controller

- Number of Axes : 6
- Repeatability : ±0.02 mm
- Manufacture : Stäubli Unimation Corp.

DASY5 Measurement server

- Features : The DASY5 measurement server is based on a PC/104 CPU board with a 400MHz intel ULV Celeron, 128MB chip-disk and 128MB RAM. The necessary circuits for communication with the DAE4 electronics box, as well as the 16 bit AD converter system for optical detection and digital I/O interface are contained on the DASY5 I/O board, which is directly connected to the PC/104 bus of the CPU board.
- Calibration : No calibration required.
- Manufacture : Schmid & Partner Engineering AG

Data Acquisition Electronic (DAE)

- Features : Signal amplifier, multiplexer, A/D converter and control logic.
Serial optical link for communication with DASY5 embedded system (fully remote controlled). 2 step probe touch detector for mechanical surface detection and emergency robot stop (not in -R version)
- Measurement Range : 1 µV to > 200 mV (16bit resolution and 2 range settings: 4 mV, 400 mV)
- Input Offset voltage : < 1 µV (with auto zero)
- Input Resistance : 200 MΩ
- Battery Power : > 10 hrs. of operation (with two 9 V battery)
- Manufacture : Schmid & Partner Engineering AG

Electro-Optical Converter (EOC61)

- Manufacture : Schmid & Partner Engineering AG

Light Beam Switch (LBS/80)

- Manufacture : Schmid & Partner Engineering AG

SAR measurement software

- Item : Dosimetric Assessment System DASY5
- Software version : Refer to Appendix 3-1 (Equipment used)
- Manufacture : Schmid & Partner Engineering AG

E-Field Probe

- Model : EX3DV4 (serial number: 3907)
- Construction : Symmetrical design with triangular core.
Built-in shielding against static charges.
PEEK enclosure material (resistant to organic solvents, e.g., DGBE).
- Frequency : 10MHz to 6GHz, Linearity: ±0.2 dB (30MHz to 6GHz)
- Conversion Factors (CF) : Head: (2.45, 5.2, 5.25, 5.5, 5.6, 5.75, 5.8) GHz
Body: (2.45, 5.25, 5.6, 5.75, 5.8) GHz
- Directivity : ±0.3 dB in HSL (rotation around probe axis)
±0.5 dB in tissue material (rotation normal to probe axis)
- Dynamic Range : 10µW/g to > 100 mW/g; Linearity: ±0.2 dB (noise: typically < 1 µW/g)
- Dimension : Overall length: 330 mm (Tip: 20 mm)
Tip diameter: 2.5 mm (Body: 12 mm)
Typical distance from probe tip to dipole centers: 1mm
- Application : High precision dosimetric measurement in any exposure scenario (e.g., very strong gradient fields). Only probe which enables compliance testing for frequencies up to 6GHz with precision of better 30%.
- Manufacture : Schmid & Partner Engineering AG

Phantom

- Model Number : **ELI 4.0 oval flat phantom**
- Shell Material : Fiberglass
- Shell Thickness : Bottom plate: 2 ±0.2 mm
- Dimensions : Bottom elliptical: 600×400 mm, Depth: 190 mm (Volume: Approx. 30 liters)
- Manufacture : Schmid & Partner Engineering AG

Device Holder

- Urethane foam
- KSDH-01: In combination with the ELI4, the Mounting Device enables the rotation of the mounted transmitter device in spherical coordinates. Transmitter devices can be easily and accurately positioned. The low-loss dielectric urethane foam was used for the mounting section of device holder.
 - Material : Polyoxymethylene (POM)
 - Manufacture : Schmid & Partner Engineering AG
- SSDH-02: A simple but effective and easy-to-use extension for the Mounting Device; facilitates testing of larger devices (e.g., laptops, cameras, etc.) according to IEC 62209-2.
 - Material : Polyoxymethylene (POM), PET-G, Foam
 - Manufacture : Schmid & Partner Engineering AG

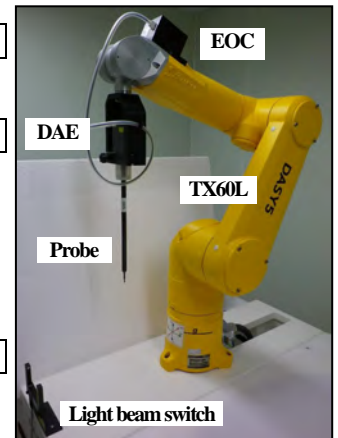

Data storage and evaluation (postprocessing)

The DASY5 software stores the measured voltage acquired by the Data Acquisition Electronics (DAE) as raw data together with all the necessary software parameters for the data evaluation (probe calibration data, liquid parameters and communication system parameters) in measurement files with the extension “.da5x”. The postprocessing software evaluates the data every time the data is visualized or exported.

The fields and SAR are calculated from the measured voltage (probe voltage acquired by the DAE) and the following parameters:

| | | |
|--------------------|-------------------------------------|-------------------------|
| Probe parameters: | - Sensitivity | $norm_i, ai0, ai1, ai2$ |
| | - Conversion Factor | $convFi$ |
| | - Diode Compression Point | dcp_i |
| | - Probe Modulation Response Factors | ai, bi, ci, d |
| Device parameters: | - Frequency | f |
| | - Crest factor | cf |
| Media parameters: | - Conductivity | σ |
| | - Relative Permittivity | ρ |

This parameters are stored in the DASY5 V52 measurement file.

These parameters must be correctly set in the DASY5 V52 software setup. They are available as configuration file and can be imported into the measurement file. The values displayed in the multimeter window are assessed using the parameters of the actual system setup. In the scan visualization and export modes, the parameters stored in the measurement file are used.

The measured voltage is not proportional to the exciting. It must be first linearized.

Approximated Probe Response Linearization using Crest Factor;

This linearization method is enabled when a custom defined communication system is measured. The compensation applied is a function of the measured voltage, the detector diode compression point and the crest factor of the measured signal.

$$V_i = U_i + U_i^2 \cdot \frac{cf}{dcp_i}$$

| | | |
|------------|---|------------------------------|
| with V_i | = linearized voltage of channel i in μV | (i = x,y,z) |
| U_i | = measured voltage of channel i in μV | (i = x,y,z) |
| cf | = crest factor of exciting field | (DASY parameter) |
| dcp_i | = diode compression point of channel i in μV | (Probe parameter, i = x,y,z) |

The resulting linearized voltage is only approximated because the probe is not calibrated to this specific signal.

Field and SAR Calculation

The primary field data for each channel are calculated using the linearized voltage:

$$E - \text{fieldprobes} : E_i = \sqrt{\frac{V_i}{Norm_i \cdot ConvF}}$$

| | | |
|------------|---|-------------|
| with V_i | = linearized voltage of channel i in μV | (i = x,y,z) |
| $Norm_i$ | = sensor sensitivity of channel i in $\mu V/(V/m)^2$ for E-field Probes | (i = x,y,z) |
| $ConvF$ | = sensitivity enhancement in solution | |
| E_i | = electric field strength of channel i in V/m | (i = x,y,z) |

The RMS value of the field components gives the total field strength (Hermitian magnitude):

$$E_{tot} = \sqrt{E_x^2 + E_y^2 + E_z^2}$$

The primary field data are used to calculate the derived field units.

$$SAR = E_{tot}^2 \cdot \frac{\sigma}{\rho \cdot 1'000}$$

| | |
|-----------|--|
| with SAR | = local specific absorption rate in mW/g |
| E_{tot} | = total field strength in V/m |
| σ | = conductivity in [mho/m] or [Siemens/m] |
| ρ | = equivalent tissue density in g/cm ³ |

Appendix 3-4: Simulated tissue composition and parameter confirmation

| | |
|--|--|
| Liquid type | Head |
| Control No. | KSLH245-01 |
| Model No./Product No. | HSL2450V2 / SL AAH 245 BA |
| Ingredient: Mixture [%] | Water: 52-75%, DGBE: 25-48%, NaCl: <1.0% |
| Temperature gradients [% / deg.C] | permittivity: +0.42 / conductivity: -2.08 (at 2.5 GHz) (*1) |
| Manufacture | Schmid & Partner Engineering AG Note: *1. Temperature_Gradient_sl2450v2&tsl5000_16.01.2011 |

*. The dielectric parameters were checked prior to assessment using the DAK3.5 dielectric probe kit.

| Measured date | Frequency [MHz] | Liquid type | Ambient [deg.C.] / [%RH] | Liquid temp. [deg.C.] | Liquid depth of phantom [mm] | Liquid parameters (*a) | | | | | | ASAR | | | |
|------------------------------|-----------------|-------------|--------------------------|-----------------------|------------------------------|------------------------|----------------|--------|--------------------|--------|----------------|---------------|----------------|-------|-------|
| | | | | | | Permittivity (εr) [-] | | | Conductivity [S/m] | | | (1g) [%] (*b) | (10g) [%] (*b) | | |
| | | | | | | Target | Measured Meas. | Δεr[%] | Limit | Target | Measured Meas. | | | Δσ[%] | Limit |
| February 24 (~25), 2021 (*1) | 2450 | Head | 24/(30~40) | 23.7 | (150) | 39.2 | 37.67 | -3.9 | ±5% | 1.80 | 1.882 | +4.5 | ±5% | +3.05 | +1.80 |

*1. On February 25, it was within 24 hours from measurement on February 24 and same liquid temperature, so parameters of February 24 were used continuously.

*a. The target values of (2000, 2450 and 3000) MHz are parameters defined in Appendix A of KDB 865664 D01. For other frequencies, the target nominal dielectric values shall be obtained by linear interpolation between the higher and lower tabulated figures.

| Standard | | | | | | | | Interpolated & Extrapolated | | | | | | | |
|-------------|-------------|---------|-------------|---------|---------|-------------|---------|-----------------------------|---------|---------|-------------|---------|-------------|---------|---|
| f (MHz) | Head Tissue | | Body Tissue | | f (MHz) | Head Tissue | | Body Tissue | | f (MHz) | Head Tissue | | Body Tissue | | |
| | εr | σ [S/m] | εr | σ [S/m] | | εr | σ [S/m] | εr | σ [S/m] | | εr | σ [S/m] | εr | σ [S/m] | |
| (1800)-2000 | 40.0 | 1.40 | 53.3 | 1.52 | 3000 | 38.5 | 2.40 | 52.0 | 2.73 | - | - | - | - | - | - |
| 2450 | 39.2 | 1.80 | 52.7 | 1.95 | | | | | | | | | | | |

*b. The coefficients are parameters defined in IEEE Std. 1528-2013.

$$\Delta SAR(1g) = C_{\epsilon r} \times \Delta \epsilon r + C_{\sigma} \times \Delta \sigma, C_{\epsilon r} = 7.854E-4 \times f^3 + 9.402E-3 \times f^2 - 2.742E-2 \times f + 0.2026 / C_{\sigma} = 9.804E-3 \times f^3 - 8.661E-2 \times f^2 + 2.981E-2 \times f + 0.7829$$

$$\Delta SAR(10g) = C_{\epsilon r} \times \Delta \epsilon r + C_{\sigma} \times \Delta \sigma, C_{\epsilon r} = 3.456 \times 10^{-3} \times f^3 - 3.531 \times 10^{-2} \times f^2 + 7.675 \times 10^{-2} \times f + 0.1860 / C_{\sigma} = 4.479 \times 10^{-3} \times f^3 - 1.586 \times 10^{-2} \times f^2 - 0.1972 \times f + 0.7717$$

Appendix 3-5: Daily check results

*. Prior to the SAR assessment of EUT, the Daily check was performed to test whether the SAR system was operating within its target of ±10%. The Daily check results are in the table below.

| Date | Frequency [MHz] | Liquid Type | Daily check results (*. Meas.: Measured, Cal.: Calibration value, STD: Standard value) | | | | | | | | | | | | | | | | | |
|-------------------|-----------------|-------------|--|--------------|-----------|-----------|----------|-----------|---------|-----------------------|--------|------------|--------------|-----------|----------|---------|-----------|------|-----------|--------|
| | | | SAR (1g) [W/kg] (*d) | | | | | | | SAR (10g) [W/kg] (*d) | | | | | | | | | | |
| | | | Meas. (*c) | ASAR-correct | 1W scaled | Target | | Deviation | | Limit [%] | Pass ? | Meas. (*c) | ASAR-correct | 1W scaled | Target | | Deviation | | Limit [%] | Pass ? |
| | | | | | | Cal. (*e) | STD (*f) | Cal. [%] | STD [%] | | | | | | Cal. [%] | STD [%] | | | | |
| February 24, 2021 | 2450 | Head | 13.7 | 13.28 | 53.12 | 53.6 | 52.4 | -0.9 | +1.4 | ±10 | Pass | 6.33 | 6.22 | 24.88 | 24.9 | 24.0 | -0.1 | +3.7 | ±10 | Pass |
| February 25, 2021 | 2450 | Head | 13.4 | 12.99 | 51.96 | 53.6 | 52.4 | -3.1 | -0.8 | ±10 | Pass | 6.15 | 6.04 | 24.16 | 24.9 | 24.0 | -3.0 | +0.7 | ±10 | Pass |

*. Calculating formula: ΔSAR corrected SAR (1g,10g) (W/kg) = (Measured SAR(1g,10g) (W/kg)) × (100 - (ASAR(%))) / 100

*c. The "Meas. (Measured)" SAR value is obtained at 250 mW for 2450MHz.

*d. The measured SAR value of Daily check was compensated for tissue dielectric deviations (ASAR) and scaled to 1W of output power in order to compare with the manufacture's calibration target value which was normalized.

*e. The target value is a parameter defined in the calibration data sheet of D2450V2 (sn:822) dipole calibrated by Schmid & Partner Engineering AG (Certification No. D2450V2-822_Nov20, the data sheet was filed in this report).

*f. The target value (normalized to 1W) is defined in IEEE Std.1528.

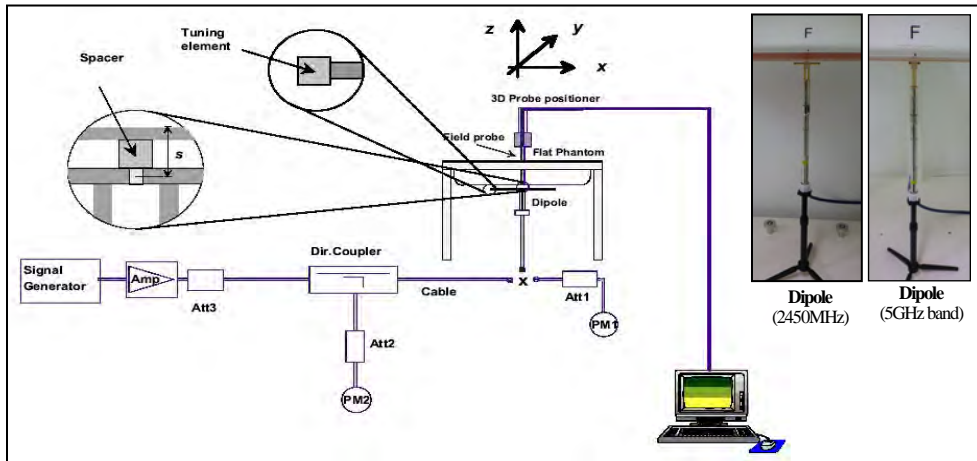

Test setup for the system performance check

Appendix 3-6: Daily check measurement data

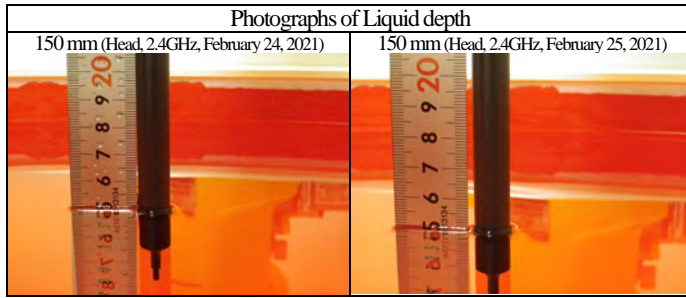

EUT: D2450V2 - SN822; Type: D2450V2; Serial: SN822; Forward conducted power: 250 mW
Communication System: CW (UID 0, Frame Length in ms: 0; Communication System PAR: 0; PMF: 1); **Frequency: 2450 MHz; Crest Factor: 1.0**
Medium: HSL2450(2102); Medium parameters used: f = 2450 MHz; $\sigma = 1.882$ S/m; $\epsilon_r = 37.67$; $\rho = 1000$ kg/m³
 Measurement Standard: DASYS5 (IEEE/IEC/ANSI C63.19-2007)

DASY Configuration: -Electronics: DAE4 Sn626; Calibrated: 2020/11/17 / -Phantom: ELI v4.0; Type: QDOVA001BA; Serial: 1059; Phantom section: Flat Section
 -DASY52 52.10.3(1513); SEMCAD X 14.6.13(7474) / -Probe: EX3DV4 - SN3907; ConvF(7.26, 7.26, 7.26) @ 2450 MHz; Calibrated: 2020/04/27
 -Sensor-Surface: 2mm (Mechanical Surface Detection), z = 1.0, 31.0, 161.0

Area:60x60,15 (5x5x1): Measurement grid: dx=15mm, dy=15mm; Maximum value of SAR (measured) = 20.6 W/kg
Area:60x60,15 (41x41x1): Interpolated grid: dx=1.500 mm, dy=1.500 mm; Maximum value of SAR (interpolated) = 20.8 W/kg
Z;160,5 (1x1x33): Measurement grid: dx=20mm, dy=20mm, dz=5mm; Maximum value of SAR (measured) = 21.4 W/kg

Zoom:30x30x30,5 (7x7x7)/Cube 0: Measurement grid: dx=5mm, dy=5mm, dz=5mm;
 Reference Value = 105.8 V/m; Power Drift = -0.02 dB; Maximum value of SAR (measured) = 21.2 W/kg; Peak SAR (extrapolated) = 28.9 W/kg
SAR(1 g) = 13.7 W/kg; SAR(10 g) = 6.33 W/kg (*. Smallest distance from peaks to all points 3 dB below = 9.8 mm; Ratio of SAR at M2 to SAR at M1 = 47.7%)

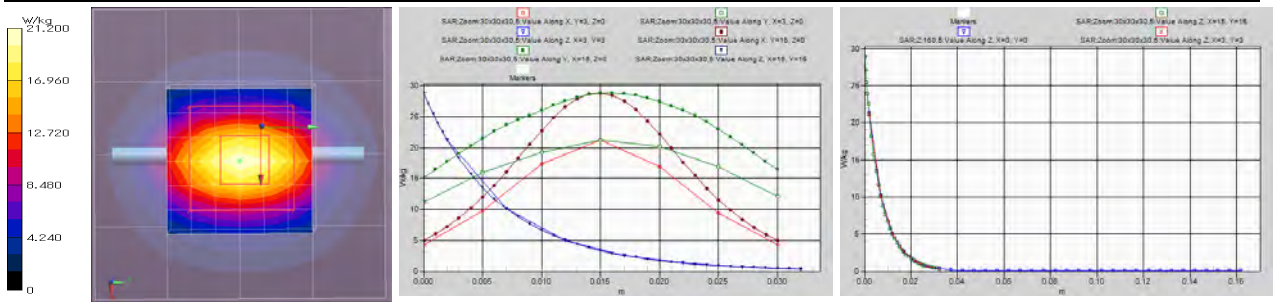

Remarks: * Date tested: 2021/2/24; Tested by: Hiroshi Naka; Tested place: No.7 shielded room,
 * liquid depth: 150 mm; Position: distance of dipole to phantom: 8mm (10mm to liquid); ambient: 25 deg.C. / (30~40) %RH,
 * liquid temperature: 23.6(start)/23.5(end)/23.7(in check) deg.C.; *. White cubic: zoom scan area, Red cubic: big=SAR(10g) / small=SAR(1g)

EUT: D2450V2 - SN822; Type: D2450V2; Serial: SN822; Forward conducted power: 250 mW
Communication System: CW (UID 0, Frame Length in ms: 0; Communication System PAR: 0; PMF: 1); **Frequency: 2450 MHz; Crest Factor: 1.0**
Medium: HSL2450(2102); Medium parameters used: f = 2450 MHz; $\sigma = 1.882$ S/m; $\epsilon_r = 37.67$; $\rho = 1000$ kg/m³
 Measurement Standard: DASYS5 (IEEE/IEC/ANSI C63.19-2007)

DASY Configuration: -Electronics: DAE4 Sn626; Calibrated: 2020/11/17 / -Phantom: ELI v4.0; Type: QDOVA001BA; Serial: 1059; Phantom section: Flat Section
 -DASY52 52.10.3(1513); SEMCAD X 14.6.13(7474) / -Probe: EX3DV4 - SN3907; ConvF(7.26, 7.26, 7.26) @ 2450 MHz; Calibrated: 2020/04/27
 -Sensor-Surface: 2mm (Mechanical Surface Detection), z = 1.0, 31.0, 161.0

Area:60x60,15 (5x5x1): Measurement grid: dx=15mm, dy=15mm; Maximum value of SAR (measured) = 20.3 W/kg
Area:60x60,15 (41x41x1): Interpolated grid: dx=1.500 mm, dy=1.500 mm; Maximum value of SAR (interpolated) = 20.7 W/kg
Z;160,5 (1x1x33): Measurement grid: dx=20mm, dy=20mm, dz=5mm; Maximum value of SAR (measured) = 20.7 W/kg

Zoom:30x30x30,5 (7x7x7)/Cube 0: Measurement grid: dx=5mm, dy=5mm, dz=5mm;
 Reference Value = 105.2 V/m; Power Drift = -0.01 dB; Maximum value of SAR (measured) = 20.7 W/kg; Peak SAR (extrapolated) = 28.4 W/kg
SAR(1 g) = 13.4 W/kg; SAR(10 g) = 6.15 W/kg (*. Smallest distance from peaks to all points 3 dB below = 9.8 mm; Ratio of SAR at M2 to SAR at M1 = 47.4%)

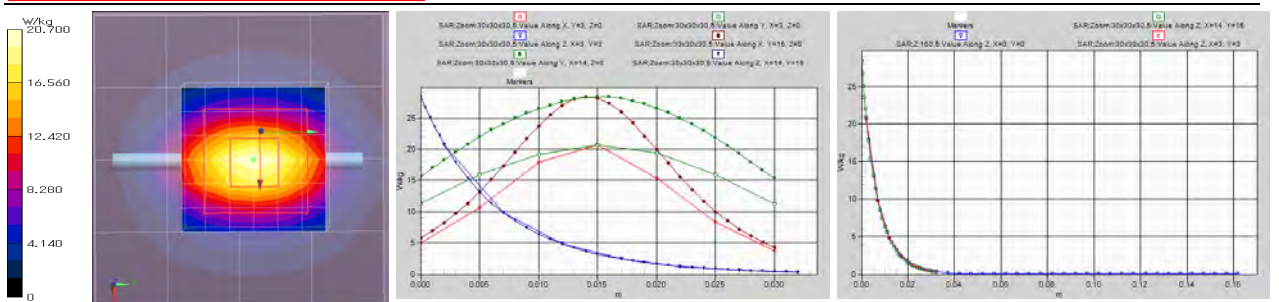

Remarks: * Date tested: 2021/2/25; Tested by: Hiroshi Naka; Tested place: No.7 shielded room,
 * liquid depth: 150 mm; Position: distance of dipole to phantom: 8mm (10mm to liquid); ambient: 25 deg.C. / (30~40) %RH,
 * liquid temperature: 23.3(start)/23.4(end)/23.7(in check) deg.C.; *. White cubic: zoom scan area, Red cubic: big=SAR(10g) / small=SAR(1g)

Appendix 3-7: Calibration certificate: E-Field Probe (EX3DV4)

**Calibration Laboratory of
Schmid & Partner
Engineering AG**
Zoughausstrasse 43, 8004 Zurich, Switzerland



S Schweizerischer Kalibrierdienst
C Service suisse d'étalonnage
S Servizio svizzero di taratura
S Swiss Calibration Service

Accredited by the Swiss Accreditation Service (SAS)
The Swiss Accreditation Service is one of the signatories to the EA
Multilateral Agreement for the recognition of calibration certificates

Accreditation No.: **SCS 0108**

Client **UL Japan (RCC)**

Certificate No: **EX3-3907_Apr20**

CALIBRATION CERTIFICATE

Object **EX3DV4 - SN:3907**

Calibration procedure(s) **QA CAL-01.v9, QA CAL-14.v5, QA CAL-23.v5, QA CAL-25.v7
Calibration procedure for dosimetric E-field probes**

Calibration date: **April 27, 2020**

This calibration certificate documents the traceability to national standards, which realize the physical units of measurements (SI).
The measurements and the uncertainties with confidence probability are given on the following pages and are part of the certificate.

All calibrations have been conducted in the closed laboratory facility: environment temperature (22 ± 3)°C and humidity < 70%.

Calibration Equipment used (M&TE critical for calibration)

| Primary Standards | ID | Cal Date (Certificate No.) | Scheduled Calibration |
|----------------------------|------------------|-----------------------------------|------------------------|
| Power meter NRP | SN: 104778 | 01-Apr-20 (No. 217-03100/03101) | Apr-21 |
| Power sensor NRP-Z91 | SN: 103244 | 01-Apr-20 (No. 217-03100) | Apr-21 |
| Power sensor NRP-Z91 | SN: 103245 | 01-Apr-20 (No. 217-03101) | Apr-21 |
| Reference 20 dB Attenuator | SN: CC2552 (20x) | 31-Mar-20 (No. 217-03106) | Apr-21 |
| DAE4 | SN: 660 | 27-Dec-19 (No. DAE4-660_Dec19) | Dec-20 |
| Reference Probe ES3DV2 | SN: 3013 | 31-Dec-19 (No. ES3-3013_Dec19) | Dec-20 |
| Secondary Standards | ID | Check Date (in house) | Scheduled Check |
| Power meter E4419B | SN: GB41293874 | 06-Apr-16 (in house check Jun-18) | In house check: Jun-20 |
| Power sensor E4412A | SN: MY41498087 | 06-Apr-16 (in house check Jun-18) | In house check: Jun-20 |
| Power sensor E4412A | SN: 000110210 | 06-Apr-16 (in house check Jun-18) | In house check: Jun-20 |
| RF generator HP 8648C | SN: US3642U01700 | 04-Aug-99 (in house check Jun-18) | In house check: Jun-20 |
| Network Analyzer E8358A | SN: US41080477 | 31-Mar-14 (in house check Oct-19) | In house check: Oct-20 |

| | | | |
|----------------|------------------------------|--|---------------|
| Calibrated by: | Name Leif Klysner | Function Laboratory Technician | Signature |
| Approved by: | Name Katja Pokovic | Function Technical Manager | |

Issued: April 27, 2020

This calibration certificate shall not be reproduced except in full without written approval of the laboratory.

Appendix 3-7: Calibration certificate: E-Field Probe (EX3DV4) (cont'd)

Calibration Laboratory of
Schmid & Partner
Engineering AG
 Zeughausstrasse 43, 8004 Zurich, Switzerland



S Schweizerischer Kalibrierdienst
C Service suisse d'étalonnage
S Servizio svizzero di taratura
S Swiss Calibration Service

Accredited by the Swiss Accreditation Service (SAS)

Accreditation No.: **SCS 0108**

The Swiss Accreditation Service is one of the signatories to the EA
 Multilateral Agreement for the recognition of calibration certificates

Glossary:

| | |
|--------------------------|---|
| TSL | tissue simulating liquid |
| NORM _{x,y,z} | sensitivity in free space |
| ConvF | sensitivity in TSL / NORM _{x,y,z} |
| DCP | diode compression point |
| CF | crest factor (1/duty_cycle) of the RF signal |
| A, B, C, D | modulation dependent linearization parameters |
| Polarization φ | φ rotation around probe axis |
| Polarization ϑ | ϑ rotation around an axis that is in the plane normal to probe axis (at measurement center), i.e., $\vartheta = 0$ is normal to probe axis |
| Connector Angle | information used in DASY system to align probe sensor X to the robot coordinate system |

Calibration is Performed According to the Following Standards:

- IEEE Std 1528-2013, "IEEE Recommended Practice for Determining the Peak Spatial-Averaged Specific Absorption Rate (SAR) in the Human Head from Wireless Communications Devices: Measurement Techniques", June 2013
- IEC 62209-1, "Measurement procedure for the assessment of Specific Absorption Rate (SAR) from hand-held and body-mounted devices used next to the ear (frequency range of 300 MHz to 6 GHz)", July 2016
- IEC 62209-2, "Procedure to determine the Specific Absorption Rate (SAR) for wireless communication devices used in close proximity to the human body (frequency range of 30 MHz to 6 GHz)", March 2010
- KDB 865664, "SAR Measurement Requirements for 100 MHz to 6 GHz"

Methods Applied and Interpretation of Parameters:

- NORM_{x,y,z}**: Assessed for E-field polarization $\vartheta = 0$ ($f \leq 900$ MHz in TEM-cell; $f > 1800$ MHz: R22 waveguide). NORM_{x,y,z} are only intermediate values, i.e., the uncertainties of NORM_{x,y,z} does not affect the E²-field uncertainty inside TSL (see below ConvF).
- NORM(f)_{x,y,z} = NORM_{x,y,z} * frequency_response** (see Frequency Response Chart). This linearization is implemented in DASY4 software versions later than 4.2. The uncertainty of the frequency response is included in the stated uncertainty of ConvF.
- DCP_{x,y,z}**: DCP are numerical linearization parameters assessed based on the data of power sweep with CW signal (no uncertainty required). DCP does not depend on frequency nor media.
- PAR**: PAR is the Peak to Average Ratio that is not calibrated but determined based on the signal characteristics
- A_{x,y,z}; B_{x,y,z}; C_{x,y,z}; D_{x,y,z}; VR_{x,y,z}; A, B, C, D** are numerical linearization parameters assessed based on the data of power sweep for specific modulation signal. The parameters do not depend on frequency nor media. VR is the maximum calibration range expressed in RMS voltage across the diode.
- ConvF and Boundary Effect Parameters**: Assessed in flat phantom using E-field (or Temperature Transfer Standard for $f \leq 800$ MHz) and inside waveguide using analytical field distributions based on power measurements for $f > 800$ MHz. The same setups are used for assessment of the parameters applied for boundary compensation (alpha, depth) of which typical uncertainty values are given. These parameters are used in DASY4 software to improve probe accuracy close to the boundary. The sensitivity in TSL corresponds to NORM_{x,y,z} * ConvF whereby the uncertainty corresponds to that given for ConvF. A frequency dependent ConvF is used in DASY version 4.4 and higher which allows extending the validity from ± 50 MHz to ± 100 MHz.
- Spherical isotropy (3D deviation from isotropy)**: in a field of low gradients realized using a flat phantom exposed by a patch antenna.
- Sensor Offset**: The sensor offset corresponds to the offset of virtual measurement center from the probe tip (on probe axis). No tolerance required.
- Connector Angle**: The angle is assessed using the information gained by determining the NORM_x (no uncertainty required).

Appendix 3-7: Calibration certificate: E-Field Probe (EX3DV4) (cont'd)

EX3DV4 – SN:3907

April 27, 2020

DASY/EASY - Parameters of Probe: EX3DV4 - SN:3907**Basic Calibration Parameters**

| | Sensor X | Sensor Y | Sensor Z | Unc (k=2) |
|---|----------|----------|----------|-----------|
| Norm ($\mu\text{V}/(\text{V}/\text{m})^2$) ^A | 0.45 | 0.58 | 0.55 | ± 10.1 % |
| DCP (mV) ^B | 103.3 | 102.6 | 99.4 | |

Calibration Results for Modulation Response

| UID | Communication System Name | | A dB | B dB $\sqrt{\mu\text{V}}$ | C | D dB | VR mV | Max dev. | Unc ^E (k=2) |
|-----|---------------------------|---|---------|------------------------------|-----|---------|----------|-------------|---------------------------|
| 0 | CW | X | 0.0 | 0.0 | 1.0 | 0.00 | 157.9 | ± 2.5 % | ± 4.7 % |
| | | Y | 0.0 | 0.0 | 1.0 | | 155.3 | | |
| | | Z | 0.0 | 0.0 | 1.0 | | 149.4 | | |

The reported uncertainty of measurement is stated as the standard uncertainty of measurement multiplied by the coverage factor k=2, which for a normal distribution corresponds to a coverage probability of approximately 95%.

^A The uncertainties of Norm X,Y,Z do not affect the E²-field uncertainty inside TSL (see Pages 5 and 6).

^B Numerical linearization parameter: uncertainty not required.

^E Uncertainty is determined using the max. deviation from linear response applying rectangular distribution and is expressed for the square of the field value.

Appendix 3-7: Calibration certificate: E-Field Probe (EX3DV4) (cont'd)

EX3DV4- SN:3907

April 27, 2020

DASY/EASY - Parameters of Probe: EX3DV4 - SN:3907**Other Probe Parameters**

| | |
|---|------------|
| Sensor Arrangement | Triangular |
| Connector Angle (°) | 37.3 |
| Mechanical Surface Detection Mode | enabled |
| Optical Surface Detection Mode | disabled |
| Probe Overall Length | 337 mm |
| Probe Body Diameter | 10 mm |
| Tip Length | 9 mm |
| Tip Diameter | 2.5 mm |
| Probe Tip to Sensor X Calibration Point | 1 mm |
| Probe Tip to Sensor Y Calibration Point | 1 mm |
| Probe Tip to Sensor Z Calibration Point | 1 mm |
| Recommended Measurement Distance from Surface | 1.4 mm |

Appendix 3-7: Calibration certificate: E-Field Probe (EX3DV4) (cont'd)

EX3DV4- SN:3907

April 27, 2020

DASY/EASY - Parameters of Probe: EX3DV4 - SN:3907**Calibration Parameter Determined in Head Tissue Simulating Media**

| f (MHz) ^C | Relative Permittivity ^F | Conductivity (S/m) ^F | ConvF X | ConvF Y | ConvF Z | Alpha ^G | Depth ^G (mm) | Unc (k=2) |
|----------------------|------------------------------------|---------------------------------|---------|---------|---------|--------------------|-------------------------|-----------|
| 2450 | 39.2 | 1.80 | 7.26 | 7.26 | 7.26 | 0.40 | 0.80 | ± 12.0 % |
| 5200 | 36.0 | 4.66 | 5.23 | 5.23 | 5.23 | 0.40 | 1.80 | ± 13.1 % |
| 5250 | 35.9 | 4.71 | 5.08 | 5.08 | 5.08 | 0.40 | 1.80 | ± 13.1 % |
| 5500 | 35.6 | 4.96 | 4.66 | 4.66 | 4.66 | 0.40 | 1.80 | ± 13.1 % |
| 5600 | 35.5 | 5.07 | 4.51 | 4.51 | 4.51 | 0.40 | 1.80 | ± 13.1 % |
| 5750 | 35.4 | 5.22 | 4.68 | 4.68 | 4.68 | 0.40 | 1.80 | ± 13.1 % |
| 5800 | 35.3 | 5.27 | 4.55 | 4.55 | 4.55 | 0.40 | 1.80 | ± 13.1 % |

^C Frequency validity above 300 MHz of ± 100 MHz only applies for DASY v4.4 and higher (see Page 2), else it is restricted to ± 50 MHz. The uncertainty is the RSS of the ConvF uncertainty at calibration frequency and the uncertainty for the indicated frequency band. Frequency validity below 300 MHz is ± 10, 25, 40, 50 and 70 MHz for ConvF assessments at 30, 64, 128, 150 and 220 MHz respectively. Validity of ConvF assessed at 6 MHz is 4-9 MHz, and ConvF assessed at 13 MHz is 9-19 MHz. Above 5 GHz frequency validity can be extended to ± 110 MHz.

^F At frequencies below 3 GHz, the validity of tissue parameters (ϵ and σ) can be relaxed to ± 10% if liquid compensation formula is applied to measured SAR values. At frequencies above 3 GHz, the validity of tissue parameters (ϵ and σ) is restricted to ± 5%. The uncertainty is the RSS of the ConvF uncertainty for indicated target tissue parameters.

^G Alpha/Depth are determined during calibration. SPEAG warrants that the remaining deviation due to the boundary effect after compensation is always less than ± 1% for frequencies below 3 GHz and below ± 2% for frequencies between 3-6 GHz at any distance larger than half the probe tip diameter from the boundary.

Appendix 3-7: Calibration certificate: E-Field Probe (EX3DV4) (cont'd)

EX3DV4- SN:3907

April 27, 2020

DASY/EASY - Parameters of Probe: EX3DV4 - SN:3907**Calibration Parameter Determined in Body Tissue Simulating Media**

| f (MHz) ^C | Relative Permittivity ^F | Conductivity (S/m) ^F | ConvF X | ConvF Y | ConvF Z | Alpha ^G | Depth ^G (mm) | Unc (k=2) |
|----------------------|------------------------------------|---------------------------------|---------|---------|---------|--------------------|-------------------------|-----------|
| 2450 | 52.7 | 1.95 | 7.49 | 7.49 | 7.49 | 0.44 | 0.85 | ± 12.0 % |
| 5250 | 48.9 | 5.36 | 4.50 | 4.50 | 4.50 | 0.50 | 1.90 | ± 13.1 % |
| 5600 | 48.5 | 5.77 | 3.87 | 3.87 | 3.87 | 0.50 | 1.90 | ± 13.1 % |
| 5750 | 48.3 | 5.94 | 4.07 | 4.07 | 4.07 | 0.50 | 1.90 | ± 13.1 % |
| 5800 | 48.2 | 6.00 | 3.98 | 3.98 | 3.98 | 0.50 | 1.90 | ± 13.1 % |

^C Frequency validity above 300 MHz of ± 100 MHz only applies for DASY v4.4 and higher (see Page 2), else it is restricted to ± 50 MHz. The uncertainty is the RSS of the ConvF uncertainty at calibration frequency and the uncertainty for the indicated frequency band. Frequency validity below 300 MHz is ± 10, 25, 40, 50 and 70 MHz for ConvF assessments at 30, 64, 128, 150 and 220 MHz respectively. Validity of ConvF assessed at 6 MHz is 4-9 MHz, and ConvF assessed at 13 MHz is 9-19 MHz. Above 5 GHz frequency validity can be extended to ± 110 MHz.

^F At frequencies below 3 GHz, the validity of tissue parameters (ϵ and σ) can be relaxed to ± 10% if liquid compensation formula is applied to measured SAR values. At frequencies above 3 GHz, the validity of tissue parameters (ϵ and σ) is restricted to ± 5%. The uncertainty is the RSS of the ConvF uncertainty for indicated target tissue parameters.

^G Alpha/Depth are determined during calibration. SPEAG warrants that the remaining deviation due to the boundary effect after compensation is always less than ± 1% for frequencies below 3 GHz and below ± 2% for frequencies between 3-6 GHz at any distance larger than half the probe tip diameter from the boundary.

Appendix 3-7: Calibration certificate: E-Field Probe (EX3DV4) (cont'd)

EX3DV4- SN:3907

April 27, 2020

**Frequency Response of E-Field
(TEM-Cell:ifi110 EXX, Waveguide: R22)**

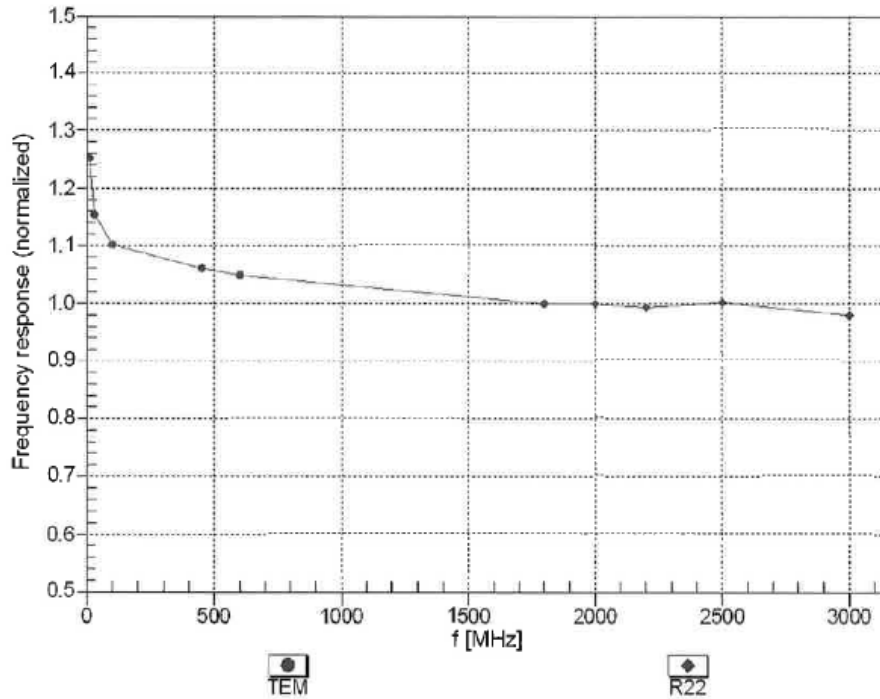

Uncertainty of Frequency Response of E-field: $\pm 6.3\%$ (k=2)

Appendix 3-7: Calibration certificate: E-Field Probe (EX3DV4) (cont'd)

EX3DV4- SN:3907

April 27, 2020

Receiving Pattern (ϕ), $\theta = 0^\circ$

f=600 MHz,TEM

f=1800 MHz,R22

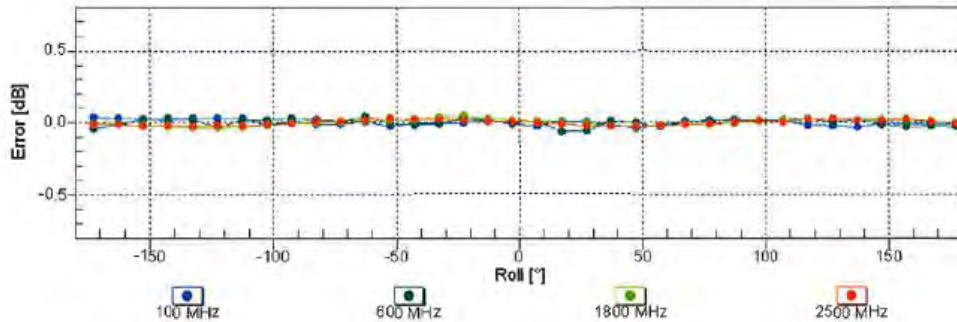
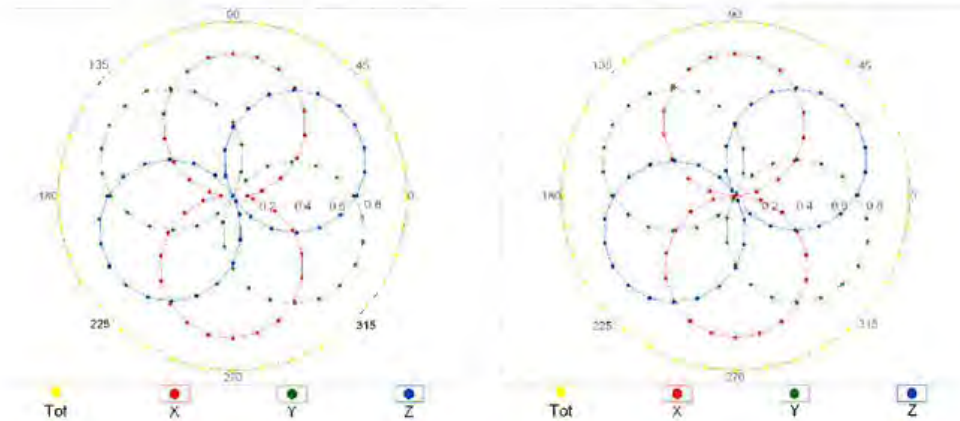

Uncertainty of Axial Isotropy Assessment: $\pm 0.5\%$ (k=2)

Appendix 3-7: Calibration certificate: E-Field Probe (EX3DV4) (cont'd)

EX3DV4- SN:3907

April 27, 2020

Dynamic Range f(SAR_{head}) (TEM cell , f_{eval}= 1900 MHz)

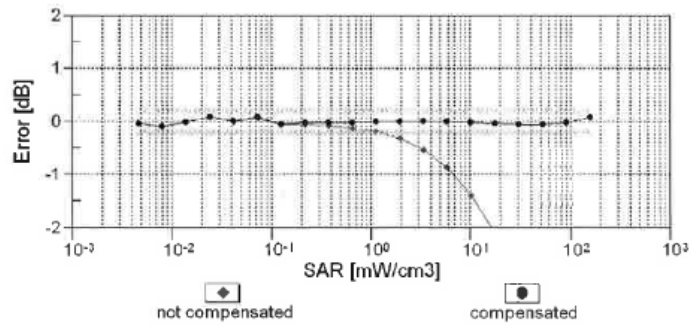
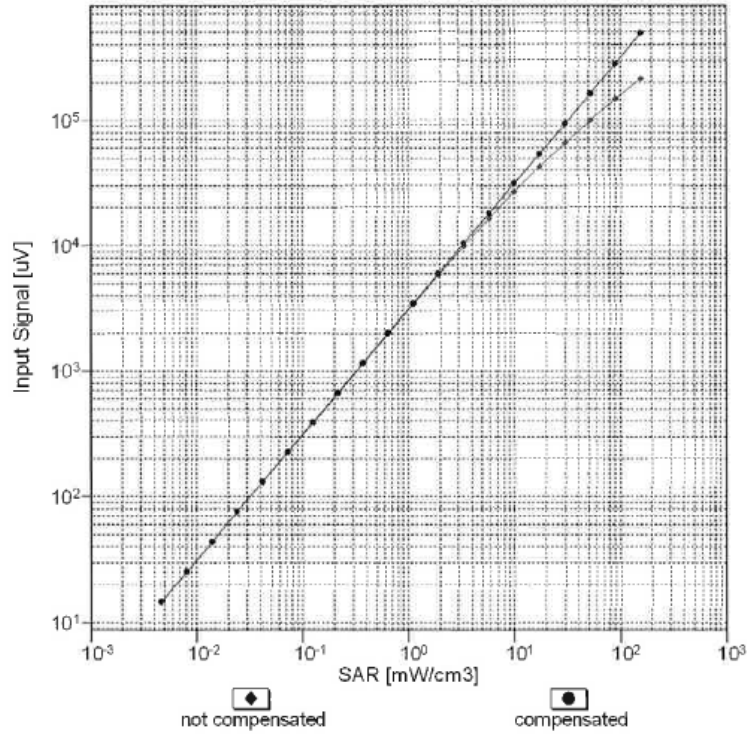

Uncertainty of Linearity Assessment: ± 0.6% (k=2)

Appendix 3-7: Calibration certificate: E-Field Probe (EX3DV4) (cont'd)

EX3DV4- SN:3907

April 27, 2020

Conversion Factor Assessment

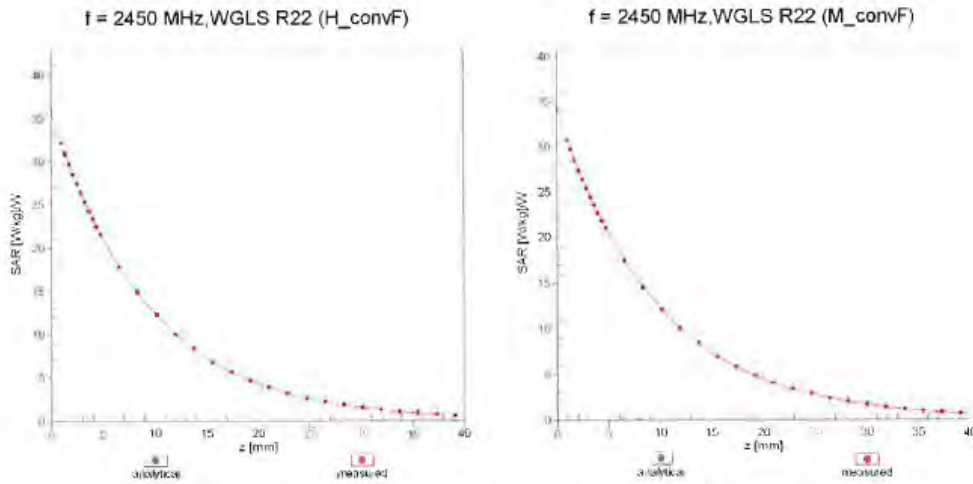

Deviation from Isotropy in Liquid

Error (ϕ, θ), f = 900 MHz

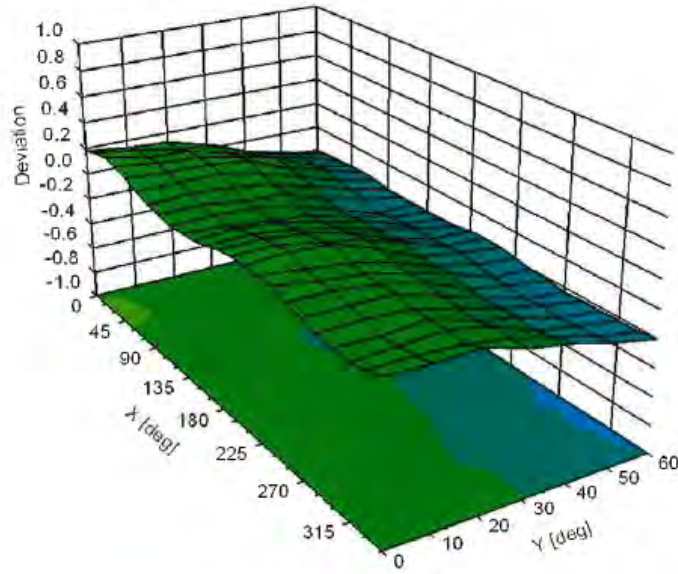

Uncertainty of Spherical Isotropy Assessment: $\pm 2.6\%$ (k=2)

Appendix 3-8: Calibration certificate: Dipole (D2450V2)

**Calibration Laboratory of
Schmid & Partner
Engineering AG**
Zeughausstrasse 43, 8004 Zurich, Switzerland



S Schwalzerischer Kalibrierdienst
C Service suisse d'étalonnage
S Servizio svizzero di taratura
S Swiss Calibration Service

Accredited by the Swiss Accreditation Service (SAS)
The Swiss Accreditation Service is one of the signatories to the EA
Multilateral Agreement for the recognition of calibration certificates

Accreditation No.: **SCS 0108**

Client **UL Japan (RCC)**

Certificate No: **D2450V2-822_Nov20**

| CALIBRATION CERTIFICATE | | | |
|---|---|-----------------------------------|------------------------------|
| Object | D2450V2 - SN:822 | | |
| Calibration procedure(s) | QA CAL-05.v11 Calibration Procedure for SAR Validation Sources between 0.7-3 GHz | | |
| Calibration date: | November 10, 2020 | | |
| This calibration certificate documents the traceability to national standards, which realize the physical units of measurements (SI). The measurements and the uncertainties with confidence probability are given on the following pages and are part of the certificate. | | | |
| All calibrations have been conducted in the closed laboratory facility: environment temperature (22 ± 3)°C and humidity < 70%. | | | |
| Calibration Equipment used (M&TE critical for calibration) | | | |
| Primary Standards | ID # | Cal Date (Certificate No.) | Scheduled Calibration |
| Power meter NRP | SN: 104778 | 01-Apr-20 (No. 217-03100/03101) | Apr-21 |
| Power sensor NRP-Z91 | SN: 103244 | 01-Apr-20 (No. 217-03100) | Apr-21 |
| Power sensor NRP-Z91 | SN: 103245 | 01-Apr-20 (No. 217-03101) | Apr-21 |
| Reference 20 dB Attenuator | SN: BH8394 (20k) | 31-Mar-20 (No. 217-03106) | Apr-21 |
| Type-N mismatch combination | SN: 310982 / 06327 | 31-Mar-20 (No. 217-03104) | Apr-21 |
| Reference Probe EX3DV4 | SN: 7405 | 29-Jun-20 (No. EX3-7405_Jun20) | Jun-21 |
| DAE4 | SN: 601 | 02-Nov-20 (No. DAE4-601_Nov20) | Nov-21 |
| Secondary Standards | ID # | Check Date (in house) | Scheduled Check |
| Power meter E4419B | SN: GB39512475 | 30-Oct-14 (in house check Oct-20) | In house check: Oct-22 |
| Power sensor HP 8481A | SN: US37292783 | 07-Oct-15 (in house check Oct-20) | In house check: Oct-22 |
| Power sensor HP 8481A | SN: MY41092317 | 07-Oct-15 (in house check Oct-20) | In house check: Oct-22 |
| RF generator R&S SMT-06 | SN: 100972 | 15-Jun-15 (in house check Oct-20) | In house check: Oct-22 |
| Network Analyzer Agilent E8358A | SN: US41060477 | 31-Mar-14 (in house check Oct-20) | In house check: Oct-21 |
| Calibrated by: | Name Michael Weber | Function Laboratory Technician | Signature |
| Approved by: | Name Katja Pokovic | Function Technical Manager | Signature |
| | | | Issued: November 11, 2020 |
| This calibration certificate shall not be reproduced except in full without written approval of the laboratory. | | | |

Appendix 3-8: Calibration certificate: Dipole (D2450V2) (cont'd)

**Calibration Laboratory of
Schmid & Partner
Engineering AG**
Zeughausstrasse 43, 8004 Zurich, Switzerland



S Schweizerischer Kalibrierdienst
C Service suisse d'étalonnage
S Servizio svizzero di taratura
S Swiss Calibration Service

Accredited by the Swiss Accreditation Service (SAS)

The Swiss Accreditation Service is one of the signatories to the EA Multilateral Agreement for the recognition of calibration certificates

Accreditation No.: **SCS 0108**

Glossary:

| | |
|-------|---------------------------------|
| TSL | tissue simulating liquid |
| ConvF | sensitivity in TSL / NORM x,y,z |
| N/A | not applicable or not measured |

Calibration is Performed According to the Following Standards:

- IEEE Std 1528-2013, "IEEE Recommended Practice for Determining the Peak Spatial-Averaged Specific Absorption Rate (SAR) in the Human Head from Wireless Communications Devices: Measurement Techniques", June 2013
- IEC 62209-1, "Measurement procedure for the assessment of Specific Absorption Rate (SAR) from hand-held and body-mounted devices used next to the ear (frequency range of 300 MHz to 6 GHz)", July 2016
- IEC 62209-2, "Procedure to determine the Specific Absorption Rate (SAR) for wireless communication devices used in close proximity to the human body (frequency range of 30 MHz to 6 GHz)", March 2010
- KDB 865664, "SAR Measurement Requirements for 100 MHz to 6 GHz"

Additional Documentation:

- DASY4/5 System Handbook

Methods Applied and Interpretation of Parameters:

- Measurement Conditions:** Further details are available from the Validation Report at the end of the certificate. All figures stated in the certificate are valid at the frequency indicated.
- Antenna Parameters with TSL:** The dipole is mounted with the spacer to position its feed point exactly below the center marking of the flat phantom section, with the arms oriented parallel to the body axis.
- Feed Point Impedance and Return Loss:** These parameters are measured with the dipole positioned under the liquid filled phantom. The impedance stated is transformed from the measurement at the SMA connector to the feed point. The Return Loss ensures low reflected power. No uncertainty required.
- Electrical Delay:** One-way delay between the SMA connector and the antenna feed point. No uncertainty required.
- SAR measured:** SAR measured at the stated antenna input power.
- SAR normalized:** SAR as measured, normalized to an input power of 1 W at the antenna connector.
- SAR for nominal TSL parameters:** The measured TSL parameters are used to calculate the nominal SAR result.

The reported uncertainty of measurement is stated as the standard uncertainty of measurement multiplied by the coverage factor $k=2$, which for a normal distribution corresponds to a coverage probability of approximately 95%.

Appendix 3-8: Calibration certificate: Dipole (D2450V2) (cont'd)**Measurement Conditions**

DASY system configuration, as far as not given on page 1.

| | | |
|------------------------------|------------------------|-------------|
| DASY Version | DASY5 | V52.10.4 |
| Extrapolation | Advanced Extrapolation | |
| Phantom | Modular Flat Phantom | |
| Distance Dipole Center - TSL | 10 mm | with Spacer |
| Zoom Scan Resolution | dx, dy, dz = 5 mm | |
| Frequency | 2450 MHz \pm 1 MHz | |

Head TSL parameters

The following parameters and calculations were applied.

| | Temperature | Permittivity | Conductivity |
|---|---------------------|----------------|----------------------|
| Nominal Head TSL parameters | 22.0 °C | 39.2 | 1.80 mho/m |
| Measured Head TSL parameters | (22.0 \pm 0.2) °C | 38.1 \pm 6 % | 1.86 mho/m \pm 6 % |
| Head TSL temperature change during test | < 0.5 °C | ---- | ---- |

SAR result with Head TSL

| SAR averaged over 1 cm ³ (1 g) of Head TSL | Condition | |
|---|--------------------|--|
| SAR measured | 250 mW input power | 13.7 W/kg |
| SAR for nominal Head TSL parameters | normalized to 1W | 53.6 W/kg \pm 17.0 % (k=2) |

| SAR averaged over 10 cm ³ (10 g) of Head TSL | condition | |
|---|--------------------|--|
| SAR measured | 250 mW input power | 6.30 W/kg |
| SAR for nominal Head TSL parameters | normalized to 1W | 24.9 W/kg \pm 16.5 % (k=2) |

Body TSL parameters

The following parameters and calculations were applied.

| | Temperature | Permittivity | Conductivity |
|---|---------------------|----------------|----------------------|
| Nominal Body TSL parameters | 22.0 °C | 52.7 | 1.95 mho/m |
| Measured Body TSL parameters | (22.0 \pm 0.2) °C | 51.8 \pm 6 % | 2.03 mho/m \pm 6 % |
| Body TSL temperature change during test | < 0.5 °C | ---- | ---- |

SAR result with Body TSL

| SAR averaged over 1 cm ³ (1 g) of Body TSL | Condition | |
|---|--------------------|--|
| SAR measured | 250 mW input power | 13.3 W/kg |
| SAR for nominal Body TSL parameters | normalized to 1W | 52.0 W/kg \pm 17.0 % (k=2) |

| SAR averaged over 10 cm ³ (10 g) of Body TSL | condition | |
|---|--------------------|--|
| SAR measured | 250 mW input power | 6.16 W/kg |
| SAR for nominal Body TSL parameters | normalized to 1W | 24.3 W/kg \pm 16.5 % (k=2) |

Appendix 3-8: Calibration certificate: Dipole (D2450V2) (cont'd)**Appendix (Additional assessments outside the scope of SCS 0108)****Antenna Parameters with Head TSL**

| | |
|--------------------------------------|--------------------------------|
| Impedance, transformed to feed point | 53.3 Ω + 5.5 j Ω |
| Return Loss | - 24.1 dB |

Antenna Parameters with Body TSL

| | |
|--------------------------------------|--------------------------------|
| Impedance, transformed to feed point | 50.5 Ω + 6.7 j Ω |
| Return Loss | - 23.5 dB |

General Antenna Parameters and Design

| | |
|----------------------------------|----------|
| Electrical Delay (one direction) | 1.160 ns |
|----------------------------------|----------|

After long term use with 100W radiated power, only a slight warming of the dipole near the feedpoint can be measured.

The dipole is made of standard semirigid coaxial cable. The center conductor of the feeding line is directly connected to the second arm of the dipole. The antenna is therefore short-circuited for DC-signals. On some of the dipoles, small end caps are added to the dipole arms in order to improve matching when loaded according to the position as explained in the "Measurement Conditions" paragraph. The SAR data are not affected by this change. The overall dipole length is still according to the Standard.

No excessive force must be applied to the dipole arms, because they might bend or the soldered connections near the feedpoint may be damaged.

Additional EUT Data

| | |
|-----------------|-------|
| Manufactured by | SPEAG |
|-----------------|-------|

Appendix 3-8: Calibration certificate: Dipole (D2450V2) (cont'd)**DASY5 Validation Report for Head TSL**

Date: 10.11.2020

Test Laboratory: SPEAG, Zurich, Switzerland.

DUT: Dipole 2450 MHz; Type: D2450V2; Serial: D2450V2 - SN:822

Communication System: UID 0 - CW; Frequency: 2450 MHz

Medium parameters used: $f = 2450$ MHz; $\sigma = 1.86$ S/m; $\epsilon_r = 38.1$; $\rho = 1000$ kg/m³

Phantom section: Flat Section

Measurement Standard: DASY5 (IEEE/IEC/ANSI C63.19-2011)

DASY52 Configuration:

- Probe: EX3DV4 - SN7405; ConvF(7.81, 7.81, 7.81) @ 2450 MHz; Calibrated: 29.06.2020
- Sensor-Surface: 1.4mm (Mechanical Surface Detection)
- Electronics: DAE4 Sn601; Calibrated: 02.11.2020
- Phantom: Flat Phantom 5.0 (front); Type: QD 000 P50 AA; Serial: 1001
- DASY52 52.10.4(1527); SEMCAD X 14.6.14(7483)

Dipole Calibration for Head Tissue/Pin=250 mW, d=10mm/Zoom Scan (7x7x7)/Cube 0:

Measurement grid: dx=5mm, dy=5mm, dz=5mm

Reference Value = 116.9 V/m; Power Drift = 0.04 dB

Peak SAR (extrapolated) = 28.4 W/kg

SAR(1 g) = 13.7 W/kg; SAR(10 g) = 6.3 W/kg

Smallest distance from peaks to all points 3 dB below = 9 mm

Ratio of SAR at M2 to SAR at M1 = 48.4%

Maximum value of SAR (measured) = 23.1 W/kg

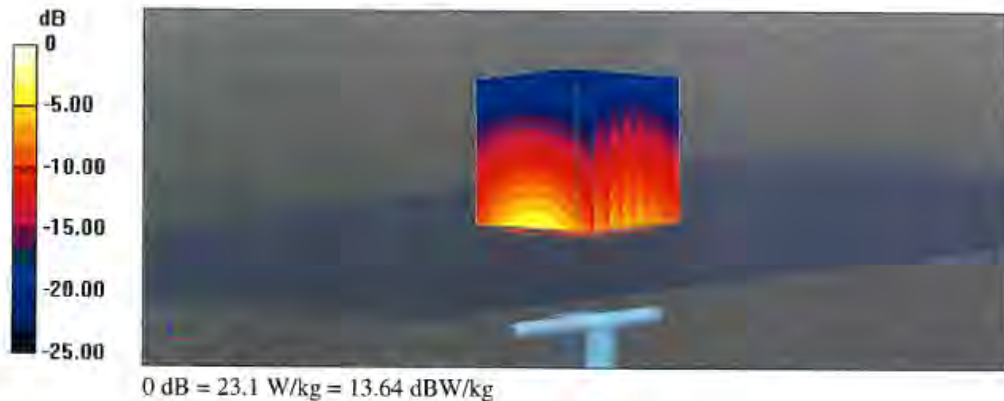

Appendix 3-8: Calibration certificate: Dipole (D2450V2) (cont'd)

Impedance Measurement Plot for Head TSL

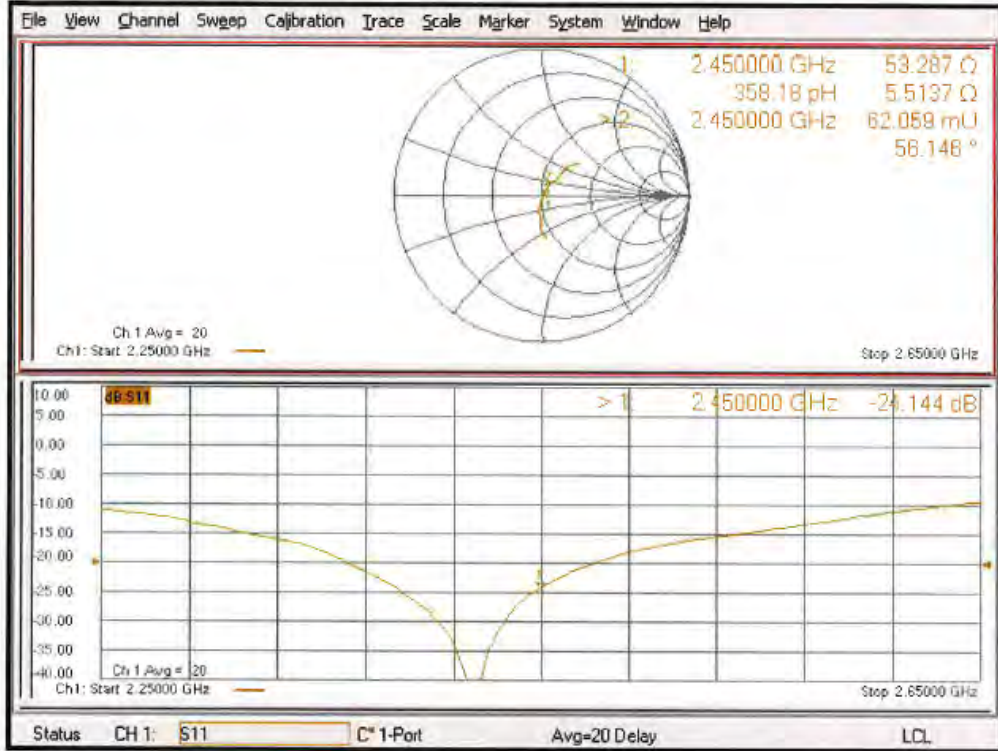

Appendix 3-8: Calibration certificate: Dipole (D2450V2) (cont'd)

DASY5 Validation Report for Body TSL

Date: 10.11.2020

Test Laboratory: SPEAG, Zurich, Switzerland

DUT: Dipole 2450 MHz; Type: D2450V2; Serial: D2450V2 - SN:822

Communication System: UID 0 - CW; Frequency: 2450 MHz

Medium parameters used: $f = 2450$ MHz; $\sigma = 2.03$ S/m; $\epsilon_r = 51.8$; $\rho = 1000$ kg/m³

Phantom section: Flat Section

Measurement Standard: DASY5 (IEEE/IEC/ANSI C63.19-2011)

DASY52 Configuration:

- Probe: EX3DV4 - SN7405; ConvF(7.75, 7.75, 7.75) @ 2450 MHz; Calibrated: 29.06.2020
- Sensor-Surface: 1.4mm (Mechanical Surface Detection)
- Electronics: DAE4 Sn601; Calibrated: 02.11.2020
- Phantom: Flat Phantom 5.0 (back); Type: QD 000 P50 AA; Serial: 1002
- DASY52 52.10.4(1527); SEMCAD X 14.6.14(7483)

Dipole Calibration for Body Tissue/Pin=250 mW, d=10mm/Zoom Scan (7x7x7)/Cube 0:

Measurement grid: dx=5mm, dy=5mm, dz=5mm

Reference Value = 108.1 V/m; Power Drift = -0.07 dB

Peak SAR (extrapolated) = 27.4 W/kg

SAR(1 g) = 13.3 W/kg; SAR(10 g) = 6.16 W/kg

Smallest distance from peaks to all points 3 dB below = 8.2 mm

Ratio of SAR at M2 to SAR at M1 = 50%

Maximum value of SAR (measured) = 21.6 W/kg

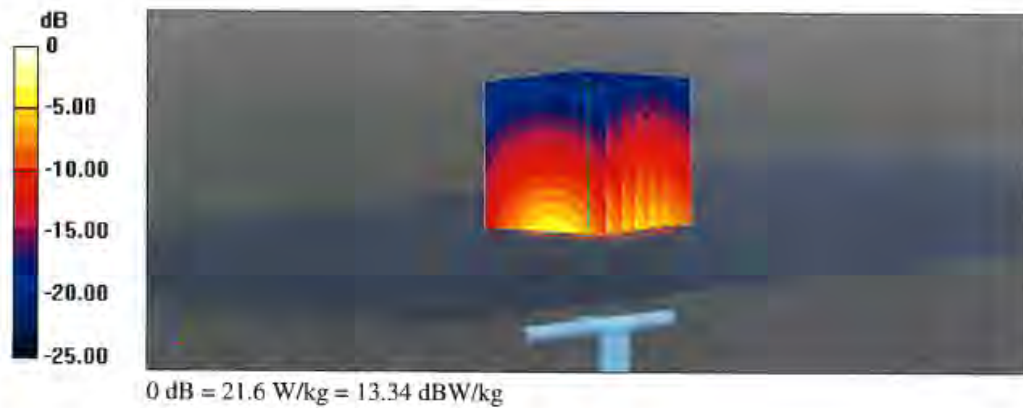

Appendix 3-8: Calibration certificate: Dipole (D2450V2) (cont'd)

Impedance Measurement Plot for Body TSL

