

RICOH

GR

RICOH GR III
Operating Manual

The serial number is located on the bottom of the camera.

Chapter 1: Introduction

Read this chapter before use.

This chapter gives you an overview of the RICOH GR III.

Chapter 2: Getting Started

Read this chapter before using the RICOH GR III for the first time.

This chapter explains how to get your RICOH GR III ready for shooting as well as basic operations.

Chapters 3 to 7

Read these chapters when you want to learn more about the different camera functions.

These chapters cover all shooting and playback functions and describe how to customize the camera settings and use it with a computer.

Model: R02010



Regarding User Registration

Thank you for purchasing a RICOH IMAGING product. In order to provide you with the best customer support and service experience for the product you have purchased, we ask you to complete the user registration.

Visit the following website to complete the user registration.

<http://www.ricoh-imaging.com/registration/>

Registered users will be notified by e-mail about important customer support information, such as firmware version updates, etc.

Introduction

This Operating Manual provides information on how to use the shooting and playback functions of this camera and related precautions.

Thoroughly read this Operating Manual to make the best use of the functions available with this camera. Be sure to keep this Operating Manual for future reference.

It is recommended to update the camera firmware to the latest version before using the camera.

For details on the latest firmware version, refer to the following firmware download site.
<http://www.ricoh-imaging.co.jp/english>

RICOH IMAGING COMPANY, LTD.

Safety precautions	Read all safety precautions thoroughly to ensure safe use.
Test shots	Take test shots to ensure that the camera is working properly before taking pictures on important occasions.
Copyright	Reproduction or alteration of copyrighted documents, magazines, and other materials, other than for personal, home, or other similarly limited purposes, without the consent of the copyright holder, is prohibited.
Exemption from liability	RICOH IMAGING COMPANY assumes no liability for failure to record or display images as a result of product malfunction.
Radio interference	Operating this camera in the vicinity of other electronic equipment may adversely affect both the camera and the other device. Interference is particularly likely if the camera is used in close proximity to a radio/TV receiver. In such case, take the following measures. <ul style="list-style-type: none">• Keep the camera as far away as possible from the radio/TV receiver.• Reorient the antenna of the radio/TV receiver.• Use a different wall outlet.

This publication may not be reproduced in whole or in part without RICOH IMAGING COMPANY's express written permission.

© RICOH IMAGING COMPANY, LTD. 2018

RICOH IMAGING COMPANY reserves the right to change the contents of this manual at any time without prior notice.

Every effort has been made to ensure the accuracy of the information in this manual. Should you nevertheless notice any errors or omissions, we would be grateful if you would notify us at the address listed on the back cover of this manual.

About the Wireless LAN Function

- Do not use the camera in a place where electrical products, AV/OA devices, and so on generate magnetic fields and electromagnetic waves.
- If the camera is affected by magnetic fields and electromagnetic waves, it may not be able to communicate.
- If the camera is used near a TV or a radio, poor reception or TV screen glitch may occur.
- If there are multiple wireless LAN access points near the camera and the same channel is used, search operation may not be executed correctly.
- The security of your data stored, sent, or received is your own responsibility.

In the frequency band used by the camera, along with industrial, scientific, and medical devices such as microwave ovens, premises radio stations (wireless stations requiring license) and specified low power radio stations (wireless stations not requiring license) for mobile object identification used in factory production lines, etc., and amateur radio stations (wireless stations requiring license) are operated.

1. Before using the camera, confirm that premises radio stations and specified low power radio stations for mobile object identification and amateur radio stations are not operated in the vicinity.
2. In the event that the camera causes harmful radio wave interference to premises radio stations for mobile object identification, immediately change the frequency being used to avoid interference.
3. If you have other troubles such that the camera causes harmful radio wave interference to specified low power radio stations for mobile object identification or to amateur radio stations, contact your nearest service center.

This camera conforms to the technical standards under the Radio Law and Telecommunications Business Law and the certification of conformance to technical standards can be displayed on the monitor.



Displaying the Certification Marks

- 1** Display the menu.
Refer to "Setting from the Menus" (p.25) for how to display the menu.
- 2** Select [Certification Marks] in the  8 menu.

Trademarks

- Microsoft and Windows are registered trademarks of Microsoft Corporation in the United States of America and other countries.
 - Macintosh, macOS, OS X, and App Store are trademarks of Apple Inc., registered in the U.S. and other countries.
 - iOS is a trademark or registered trademark of Cisco in the U.S. and other countries and is used under license.
 - Intel and Intel Core are trademarks of Intel Corporation in the U.S. and/or other countries.
 - Adobe, the Adobe logo, and Adobe Reader are registered trademarks or trademarks of Adobe Systems Incorporated in the United States and/or other countries.
 - This product includes DNG technology under license by Adobe Systems Incorporated.
 - The DNG logo is either a registered trademark or trademark of Adobe Systems Incorporated in the United States and/or other countries.
 - SDXC Logo is a trademark of SD-3C, LLC.
 - Google, Google Play, and Android are trademarks or registered trademarks of Google Inc.
 - Wi-Fi is a registered trademark of Wi-Fi Alliance.
 - The Bluetooth® word mark and logos are registered trademarks owned by Bluetooth SIG, Inc., and any use of such marks by Ricoh Company, Ltd. is under license.
 - USB Type-C is a trademark of USB Implementers Forum.
 - HDMI, the HDMI logo and High-Definition Multimedia Interface are trademarks or registered trademarks of HDMI Licensing, LLC in the United States and/or other countries.
 - MHL, the MHL Logo, and Mobile High-Definition Link are trademarks or registered trademarks of MHL, LLC in the United States and other countries.
 - Facebook is a registered trademark of Facebook, Inc.
 - Twitter is a registered trademark of Twitter, Inc.
 - Tumblr is a registered trademark of Tumblr, Inc.
- All other trademarks are the property of their respective owners.
- This product uses the RICOH RT font designed by Ricoh Company Ltd.

AVC Patent Portfolio License

This product is licensed under the AVC Patent Portfolio License for the personal use of a consumer or other uses in which it does not receive remuneration to (i) encode video in compliance with the AVC standard ("AVC video") and/or (ii) decode AVC video that was encoded by a consumer engaged in a personal activity and/or was obtained from a video provider licensed to provide AVC video. No license is granted or shall be implied for any other use. Additional information may be obtained from MPEG LA, L.L.C. See <http://www.mpegla.com>.

Announcement on the Use of BSD-Licensed Software

This product includes software licensed under the BSD License. BSD license is a form of license which permits the redistribution of the software provided that it is clearly stated that use is unwarranted, and a copyright notice and a list of licensing conditions are provided. The following contents are displayed based on the abovementioned licensing conditions and are not for the purpose of restricting your use of the product, etc.

Tera Term

Copyright (C) 1994-1998 T. Teranishi

(C) 2004-2018 TeraTerm Project

All rights reserved.

Redistribution and use in source and binary forms, with or without modification, are permitted provided that the following conditions are met:



1. Redistributions of source code must retain the above copyright notice, this list of conditions and the following disclaimer.
2. Redistributions in binary form must reproduce the above copyright notice, this list of conditions and the following disclaimer in the documentation and/or other materials provided with the distribution.
3. The name of the author may not be used to endorse or promote products derived from this software without specific prior written permission.

THIS SOFTWARE IS PROVIDED BY THE AUTHOR "AS IS" AND ANY EXPRESS OR IMPLIED WARRANTIES, INCLUDING, BUT NOT LIMITED TO, THE IMPLIED WARRANTIES OF MERCHANTABILITY AND FITNESS FOR A PARTICULAR PURPOSE ARE DISCLAIMED. IN NO EVENT SHALL THE AUTHOR BE LIABLE FOR ANY DIRECT, INDIRECT, INCIDENTAL, SPECIAL, EXEMPLARY, OR CONSEQUENTIAL DAMAGES (INCLUDING, BUT NOT LIMITED TO, PROCUREMENT OF SUBSTITUTE GOODS OR SERVICES; LOSS OF USE, DATA, OR PROFITS; OR BUSINESS INTERRUPTION) HOWEVER CAUSED AND ON ANY THEORY OF LIABILITY, WHETHER IN CONTRACT, STRICT LIABILITY, OR TORT (INCLUDING NEGLIGENCE OR OTHERWISE) ARISING IN ANY WAY OUT OF THE USE OF THIS SOFTWARE, EVEN IF ADVISED OF THE POSSIBILITY OF SUCH DAMAGE.

Safety Precautions

Warning Symbols

Various symbols are used throughout this Operating Manual and on the product to prevent physical harm to you or other people and damage to property. The symbols and their meanings are explained below.



 Danger	This symbol indicates matters that may lead to imminent risk of death or serious injury if ignored or incorrectly handled.
 Warning	This symbol indicates matters that may lead to death or serious injury if ignored or incorrectly handled.
 Caution	This symbol indicates matters that may lead to injury or physical damage if ignored or incorrectly handled.

Meaning of Symbols



The  symbol alerts you to actions that must be performed.



The  symbol alerts you to prohibited actions. The  symbol may be combined with other symbols to indicate that a specific action is prohibited.

Example:

 Do not touch  Do not disassemble

Observe the following precautions to ensure safe use of this camera.

Danger



• Do not attempt to disassemble, repair, or alter the camera yourself. The high-voltage circuitry in the equipment poses significant electrical hazard.



• Do not attempt to disassemble, alter, or directly solder the battery.



• Do not put the battery in a fire, attempt to heat it, use it in a high temperature environment such as next to a fire or inside a car, or abandon it. Do not put it into water or the sea or allow it to get wet.



• Do not attempt to pierce, hit, compress, drop, or subject the battery to any other severe impact or force.



• Do not use a battery that is significantly damaged or deformed.



• Do not connect the positive (+) and negative (-) poles of the battery with a wire or other metallic item. Also, do not carry or store together with metal objects such as ballpoint pens and necklaces.



- Use the camera or battery charger BJ-11 to charge the battery. Do not use the battery with any camera except the cameras compatible with the DB-110.



- Stop using the camera immediately in the event of abnormalities such as smoke, unusual odors, or excessive heat being emitted. Contact your nearest dealer or service center for repair.



- If the battery fluid leaks and gets into your eyes, immediately wash your eyes thoroughly with tap water or other clean water without rubbing, and seek medical attention immediately.

Warning



- Turn off the power immediately in the event of abnormalities such as smoke or unusual odors being emitted. Remove the battery as soon as possible, being careful to avoid electric shocks or burns. If you are drawing power from a household electrical outlet, be sure to unplug the power plug from the outlet. Failure to observe this precaution could result in fire or electric shocks. Contact the nearest service center at your earliest convenience. Stop using the camera immediately if it is malfunctioning.



- Turn off the power immediately if any metallic object, water, liquid, or other foreign object gets into the camera. Remove the battery and memory card as soon as possible, being careful to avoid electric shocks or burns. If you are drawing power from a household electrical outlet, be sure to unplug the power plug from the outlet. Failure to observe this precaution could result in fire or electric shocks. Contact the nearest service center at your earliest convenience. Stop using the camera immediately if it is malfunctioning.



- If the monitor is damaged, avoid any contact with the liquid crystal inside it. Follow the appropriate emergency measures below.
 - SKIN: If any of the liquid crystal gets on your skin, wipe it off and rinse the affected area thoroughly with water, then wash well with soap.
 - EYES: If it gets in your eyes, wash your eyes with clean water for at least 15 minutes and seek medical advice immediately.
 - INGESTION: If any of the liquid crystal is ingested, rinse the mouth out thoroughly with water. Have the person drink a large amount of water and induce vomiting. Seek medical assistance immediately.



- Follow these precautions to prevent the battery from leaking, overheating, igniting, or exploding.
- Do not use a battery other than those specifically recommended for the camera.
- Do not carry or store the battery together with metal objects such as ballpoint pens, necklaces, coins, and hairpins.
- Do not put the battery into a microwave or high pressure container.
- If leakage of battery fluid, a strange odor, color change, etc. is noticed during use or during charging, remove the battery from the camera or battery charger immediately and keep it away from fire.



- Observe the following in order to prevent fire, electrical shock, or cracking of the battery while charging.
- Use only the indicated power supply voltage. Also avoid the use of multi-socket adapters and extension cords.
- Do not damage, bundle, or alter power cords. Also, do not place heavy objects on, stretch, or bend power cords.
- Do not connect or disconnect the power plug with wet hands. Always grip the plug section when disconnecting a power plug. Do not cover the camera while charging the battery.



- Keep the battery and memory card used in the camera out of the reach of children to prevent accidental swallowing. The battery and memory card are harmful if swallowed. Seek medical assistance immediately.



- Keep the camera out of the reach of children. For children, accidents may occur because they cannot understand the contents of "Safety Precautions" and "Precautions for Use".



- Do not touch the internal components of the camera if they become exposed as a result of being dropped or damaged. The high-voltage circuitry in the equipment could lead to electric shocks. Remove the battery as soon as possible, being careful to avoid electric shocks or burns. Take the camera to your nearest dealer or service center if it is damaged.



- Do not use the camera in wet areas such as a kitchen. Failure to observe this precaution could result in fire or electric shocks.



- Do not use the camera near flammable gases, gasoline, benzene, thinner, or similar substances. Failure to observe this precaution could result in an explosion, fire, or burns.
- Do not use the camera in a location where usage is restricted or prohibited, such as on airplanes. Failure to observe this precaution could result in an accident.



- Wipe off any dust that accumulates on the power plug. Failure to observe this precaution could result in fire.
- When using a household power outlet, always use the dedicated AC adapter. Failure to observe this precaution could result in fire, electric shocks, or product malfunction.



- Do not use the battery charger or AC adapter with commercially available electronic transformers when traveling abroad. Failure to observe this precaution could result in fire, electric shocks, or product malfunction.



- Use only the indicated power supply voltage. Failure to observe this precaution could result in fire or electric shocks.



- Do not damage, bundle, or alter power cords. Also, to avoid damaging power cords and the risk of fire or electric shocks, do not place heavy objects on, stretch, or bend power cords.



- Do not connect or disconnect the power plug with wet hands. Failure to observe this precaution could result in electric shocks.



- Always grip the plug section when disconnecting a power plug. Do not pull the power cord. This can damage the power cord and result in fire or electric shocks.



- If any metallic object, water, liquid, or other foreign object gets into the camera, immediately remove the power plug from the outlet and contact a service center for repair. Failure to observe this precaution could result in fire or electric shocks.
- If an abnormality such as an unusual sound or smoke is emitted from the camera, immediately remove the power plug from the outlet and contact your nearest dealer or service center for repair. Stop using the camera immediately if it is malfunctioning.



- Do not attempt to disassemble the camera yourself. The high-voltage circuitry in the equipment could lead to electric shocks.



- Do not use the camera in a bathroom. Failure to observe this precaution could result in fire or electric shocks.



- Do not touch the power plug during a lightning storm. Failure to observe this precaution could result in electric shocks.



- Keep the battery out of the reach of children.



- If the battery does not finish charging after the prescribed charging time, discontinue charging.



- Do not put the battery into a microwave or high pressure container.



- If the battery leaks or emits an unusual odor, immediately move it away from any sources of fire.

 **Caution**



- Contact with fluid leaking from a battery can lead to burns. If part of your body comes in contact with a damaged battery, rinse the area with water immediately. (Do not use soap.)
If a battery starts to leak, remove it immediately from the camera and wipe the battery chamber thoroughly before replacing it with a new battery.



- Plug the power plug securely into the electrical outlets. Failure to observe this precaution could result in fire.



- Do not allow the camera to get wet. In addition, do not operate it with wet hands. Failure to observe this precaution could result in electric shocks.



- Do not fire the flash at drivers of vehicles, as this may cause the driver to lose control and result in a traffic accident. Failure to observe this precaution could result in a traffic accident.



- Remove the power plug from the outlets before cleaning the camera.
- Remove the power plug from the outlets when the camera is not used.



- Do not cover the camera while using it. Failure to observe this precaution could result in fire.
- Do not short the terminals or metal contacts on the power cords. Failure to observe this precaution could result in fire.
- Do not use the camera in wet areas or areas subject to oil smoke such as a kitchen. Failure to observe this precaution could result in fire or electric shocks.

**Safety Precautions
for Accessories**

When using optional products, carefully read the user's manuals provided with the product before using that product.

Contents

Introduction	1
Safety Precautions.....	4
1 Introduction	13
Checking the Contents of the Package	13
Names and Functions of the Working Parts.....	14
Operating Controls.....	16
Indicators on the Monitor.....	18
Shooting Screen.....	18
Playback Screen.....	19
Changing the Screen Display	20
Using the Touch Panel.....	21
How to Change Function Settings	22
Using the Button/Lever	22
Setting from the Menu	25
Menu List.....	27
📷 Still Image Settings Menu	27
🎬 Movie Settings Menu	30
▶ Playback Settings Menu.....	32
⚙️ Customize Settings Menu.....	33
🔧 Setup Menu.....	35
2 Getting Started	37
Setting the Battery and a Memory Card	37
Inserting the Battery and a Memory Card	37
Charging the Battery	38
Initial Settings	40
Turning the Camera On	40
Setting the Language and the Date and Time	41
Formatting a Memory Card.....	42
Basic Shooting Operation.....	44
Shooting in the Program Mode.....	44
Viewing the Captured Images.....	46

3 Taking Pictures 48

Taking Still Pictures	48
Setting the Exposure Mode	48
Using Exposure Compensation	53
Recording Movies	54
Playing Back Movies	56
Setting the Focus	57
Setting the Focus Mode	57
Shooting Close-ups (Macro)	61
Shooting with a Single Press of the Shutter Release Button (Full Press Snap)	62
Setting the Exposure	63
Selecting a Metering Method	63
Setting the ISO Sensitivity	64
Using a Flash	65
Reducing Noise	67
Setting the White Balance	69
Setting the White Balance Manually	72
Setting the Color Temperature	73
Setting the Drive Mode	74
Shooting Continuously (Continuous Shooting)	76
Shooting with Varied Exposure Values (Bracketing)	77
Shooting While Merging Images Together (Multi-exposure)	78
Shooting Automatically at Set Intervals (Interval Shooting)	80
Recording Star Trails (Interval Composite)	82
Using the Self-timer	84
Configuring the Capture Settings	85
Image Capture Settings	85
Movie Capture Settings	86
Setting the Image Finishing Tone and Correction	87
Using the ND Filter	87
Reducing Moiré (AA Filter Simulator)	87
Setting the Image Atmosphere (Image Control)	88
Correcting the Peripheral Illumination	90
Correcting a Range of Tones (D-Range Correction)	90
Reducing Blurring of Images	91

4 Playback Functions **92**

Using the Playback Functions	92
Changing the Playback Method	93
Displaying Multiple Images	93
Rotating Images	95
Connecting the Camera to an AV Device	96
Organizing Files	97
Deleting Files	97
Protecting Images from Deletion	98
Copying Images and Movies in the Internal Memory to a Memory Card	99
Transferring Images	100
Editing and Processing Images	101
Developing RAW Images	101
Changing the Image Size	103
Correcting Highlight/Shadow Areas (Levels Adjustment)	104
Correcting the White Balance	105
Correcting Color Moiré	106
Adjusting the Image Quality	107
Editing Movies	108

5 Sharing Images **110**

Using the Camera with a Computer	110
Using the Camera with a Communication Device	111
Connecting to a Communication Device via Bluetooth®	112
Enabling the Wireless LAN Function	114
Operating the Camera with a Communication Device	116

6 Changing the Settings **117**

Saving Frequently Used Settings	117
Saving the Settings	117
Assigning Settings to the Mode Dial	119
Using the Saved User Mode	120
Customizing the Button Functions	121
Registering Functions to the ADJ. Mode	121
Changing the Functions of the Fn Button	123
Setting the Function of the Shutter Release Button	125

Display and Sound Settings.....	126
Setting the Information Displayed During Shooting/Playback.....	126
Setting the Instant Review Display	127
Setting the Live View Display	128
Setting the Brightness and Tone of the Monitor	128
Setting the Lamp	129
Setting the Sound Effects	130
Power Saving Settings	130
Automatically Turning the Power Off.....	130
Dimming the Display.....	131
File Management Settings	132
Specifying the Folder/File Settings	132
Setting the Copyright Information.....	137

7 Appendix **139**

Attaching Optional Accessories	139
Conversion Lens/Lens Adapter.....	139
AC Adapter	140
Troubleshooting	141
Power Supply	141
Shooting.....	142
Playback/Deletion	144
Others	145
Error Messages.....	145
Main Specifications.....	147
Camera.....	147
USB Power Adapter AC-U1	151
Rechargeable Lithium-ion Battery DB-110.....	151
Image Storage Capacity	152
Operating Environment	154
Using the Camera Abroad	155
Precautions for Use	156
Camera Care and Storage.....	158
Warranty Policy.....	159
Regulatory Compliance Statements.....	160
Index.....	166

Checking the Contents of the Package

Before using your digital camera, confirm that the package contains the items listed below.



RICOH GR III



Hot shoe cover
(Installed on the camera)

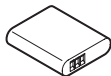

Rechargeable lithium-ion battery (DB-110)



USB power adapter (AC-U1)



Power plug

- **USB cable (I-USB166)**
- **Hand strap**
- **CD-ROM**
- **Operating Manual (this manual)**

Names and Functions of the Working Parts

1

Introduction

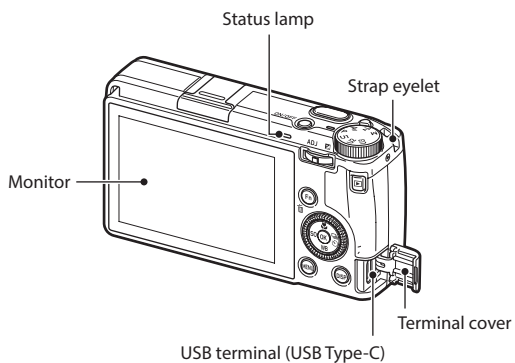
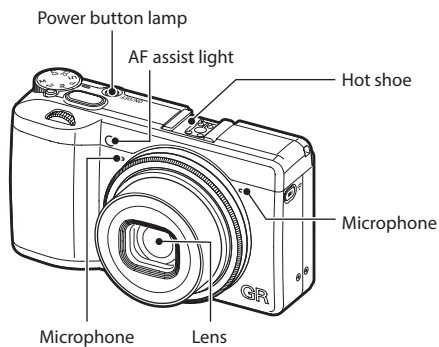

14

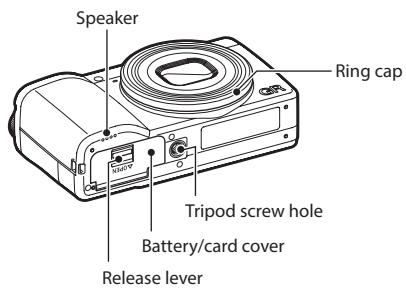

1

Introduction

Operating Controls

This section explains about operating controls.

The icons in parentheses are used in the descriptions of this manual.

1

Introduction

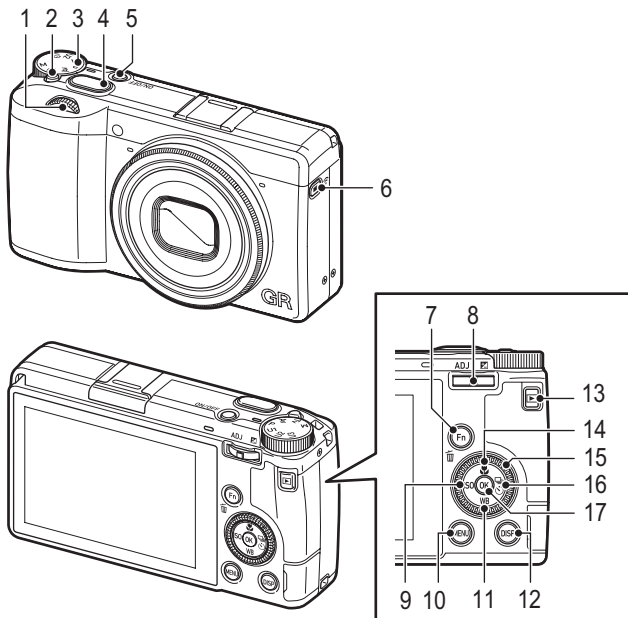

1 Front e-dial (☞)

Rotate the dial to change menu items, values for camera settings such as exposure, or images to be displayed on the screen. (p.49)

2 Lock button

Press to allow the mode dial to be turned.













3 Mode dial

Changes the exposure mode. (p.48)

4 Shutter release button (SHUTTER)

Press to capture images.

Press halfway to activate autofocus. (p.44)

- 5 Power button**
Turns the power on or off. (p.40)
- 6 Movie/Wireless button ()**
Switches between still picture mode and movie mode. (p.54)
Press and hold to turn the wireless LAN function on and off. (p.115)
- 7 Fn/Delete button ()**
Calls assigned function. (p.24)
In the playback mode, press to delete images. (p.46)
- 8 ADJ./EV compensation lever ()**
Press the lever to the left or right to change menu items, values for camera settings such as exposure, or images to be displayed on the screen.
Press to switch to ADJ. mode. (p.23)
- 9 ISO/Left button ()**
Press to change the ISO sensitivity. (p.64)
Moves the cursor to the left when an item is selected.
- 10 MENU button ()**
Displays a menu. Press this button while the menu is displayed to return to the previous screen. (p.25)
- 11 White balance/Down button ()**
Displays the white balance setting screen. (p.70)
Moves the cursor down when an item is selected.
- 12 DISP button ()**
Switches the display between the shooting information and playback information. (p.20)
Press and hold this button in shooting mode to magnify the Live View image. (p.45)
- 13 Playback button ()**
Switches between the shooting mode and the playback mode. (p.46)
- 14 Macro/Up button ()**
Switches to macro mode. (p.61)
Moves the cursor up when an item is selected.
- 15 Control dial ()**
Rotate this dial to change menu items, values for camera settings such as exposure, or images to be displayed on the screen. (p.49)
- 16 Drive/Right button ()**
Displays the drive mode setting screen. (p.74)
Moves the cursor to the right when an item is selected.
- 17 OK button ()**
Confirms the selected items such as menus.

Indicators on the Monitor

Shooting Screen

1

Introduction

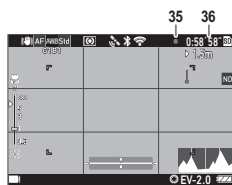
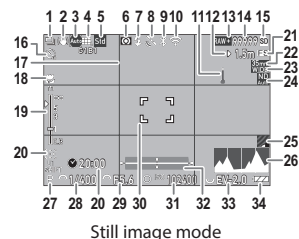

- | | | | |
|----|---|----|---|
| 1 | Drive Mode (p.74) | 20 | Operation guide |
| 2 | Shake Reduction/Movie SR (p.91) | 21 | Full Press Snap (p.62) |
| 3 | Focus mode (p.57) | 22 | Crop (p.86) |
| 4 | White Balance (p.69) | 23 | Conversion lens (p.139) |
| 5 | Image Control (p.88) | 24 | ND Filter (p.87) |
| 6 | AE Metering (p.63) | 25 | AA Filter Simulator (p.87) |
| 7 | Flash Mode (p.66) | 26 | Histogram (p.126) |
| 8 | GPS positioning status (p.116) | 27 | Exposure mode (p.48) |
| 9 | Bluetooth® communication (p.112) | 28 | Shutter speed (p.49) |
| 10 | Wireless LAN communication (p.114) | 29 | Aperture value (p.49) |
| 11 | Temperature warning | 30 | Focus frame (p.44) |
| 12 | Snap Focus Distance (p.57) | 31 | Sensitivity (p.63) |
| 13 | File Format/JPEG Recorded Pixels (p.85) | 32 | Electronic Level (p.126) |
| 14 | Number of storable images | 33 | Exposure indicator/Exposure compensation (p.53) |
| 15 | Storage location | 34 | Battery level |
| 16 | Self-timer (p.84) | 35 | Recording indicator |
| 17 | Grid Guide (p.126) | 36 | Recording time/Remaining recording time |
| 18 | Macro Mode (p.61) | | |
| 19 | Focus bar/Depth of field (p.60) | | |

18

Playback Screen

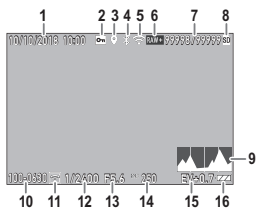

Still image mode

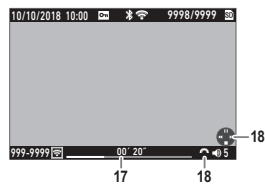

Movie mode

- 1 Shooting date and time
- 2 Protect (p.98)
- 3 GPS information (p.116)
- 4 Bluetooth® communication (p.112)
- 5 Wireless LAN communication (p.114)
- 6 File Format (p.85)
- 7 Current file/Total files
- 8 Data source
- 9 Histogram
- 10 Folder number/File number (p.132)

- 11 Transferred image (p.100)
- 12 Shutter speed
- 13 Aperture Value
- 14 Sensitivity
- 15 Exposure compensation
- 16 Battery level
- 17 Length of time of the recorded movie/
Elapsed time
- 18 Operation guide

Changing the Screen Display

You can switch the information displayed on the screen by pressing **DISP**.

1

Introduction

Shooting Mode

The information displayed on the shooting screen can be switched.

Standard Info. Display	Displays all the information.
Simplified Info. Display	Displays only the information regarding the exposure, AE lock, autofocus frame, and MF operation guide.
No Information Display	Displays the information only when camera settings are changed. Autofocus frame is displayed during range-finding.
Display Off	Does not display the autofocus frame and Live View but the information when the camera settings are changed.



Memo

- You can specify the information displayed each time **DISP** is pressed in [Shooting Info. Display] of the **C** 3 menu. (p.126)

Playback Mode

You can switch the screen display among [Standard Info. Display], [Detailed Info. Display], and [No Information Display] in the single image display. Use ▲▼ to switch the page in [Detailed Info. Display].

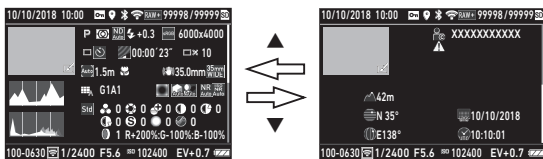

Memo

- You can specify the information displayed each time **DISP** is pressed in [Playback Info. Display] of the **C** 3 menu. (p.126)
- [Histogram], [Grid Guide], and [Highlight Alert] are not displayed for movies.

Using the Touch Panel

You can select functions, set the AF point for shooting, and operate the playback screen with the touch panel.

When not using the touch panel function, set [LCD Touch Operation] to [Off] in the **C** 2 menu.



How to Change Function Settings

Using the Button/Lever

1

Introduction

Using the Direct Keys

Quick settings are possible by pressing ▲▼◀▶ in the shooting mode. The following functions can be activated.



▲ (ISO)	Macro Mode (p.61)
▼ (WB)	White Balance (p.69)
◀ (ISO)	ISO Setting (p.63)
▶ (WB)	Drive Mode (p.74)



Memo

- The functions mentioned above can be set from the menu by pressing **MENU**.
- The functions assigned to ◀/▶ can be changed with [ISO Button] and [Drive Button] of [Fn Button Setting] in the **C 2** menu. (p.123)

Using the ADJ. Lever

The assigned functions can be easily recalled by pressing **ADJ** in the shooting mode.

1 Press **ADJ** in the shooting mode.

The mode switches to ADJ. mode and the icon for the assigned function appears.

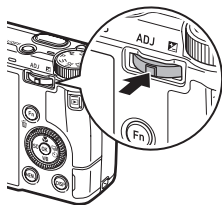

2 Use **◀▶** to select a function.

By default, the following functions can be selected.

- Image Control (p.88)
- Focus (p.57)
- File Format (p.85)
- AE Metering (p.63)
- Outdoor View Setting (p.129)



3 Use **▲▼** to select a setting.

When making detailed settings, press **Fn**.

4 Press **OK**.

The selected function is set and the camera is ready to take a picture.



Memo

- The functions for ADJ. mode can be changed in [ADJ Mode Setting] of the **C 2** menu. (p.121)
- When [Shutter Btn. Confirmation] is set to [On] in the **C 2** menu, pressing **SHUTTER** halfway completes the setting of ADJ. mode. (p.125)

Using the Fn Button

Press **Fn** in the shooting mode to activate the assigned function. By default, [AF+AE Lock] is assigned.

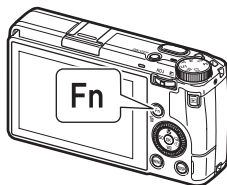

Memo

- The function of **Fn** can be changed in [Fn Button Setting] of the **C** 2 menu. [ISO Button] (◀), [Drive Button] (▶), and [Movie/Wireless Button] (⏏) can also be set in [Fn Button Setting]. (p.123)
- When the power is turned on or the mode dial is turned, the current function of the button is displayed. If [Guide Display] is set to [Off] in the **2** menu, the function is not displayed.



Fn AF+AE Lock
ISO Setting
Drive Mode
Still/Move

Setting from the Menu





Most functions are set from the menus.

1 Press **MENU**.

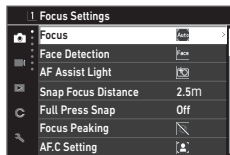

The 1 menu appears.

2 Turn  to select a menu type.



	Still Image Settings menus (p.27)
	Movie Settings menus (p.30)
	Playback Settings menus (p.32)
	Customize Settings menus (p.33)
	Setup menus (p.35)

3 Use   to select a function.

Each menu type includes 1 to 11 menus. To switch the screen display on a menu-by-menu basis, press  and then . Press  to return to the function selection.

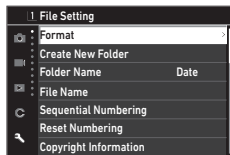

4 Find a function to set, and press ►.

The settings for the selected setting item are displayed.

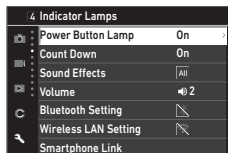

5 Use ▲▼ to select a setting, and press OK.

The screen in Step 3 reappears.

Press **MENU** to return to the previous screen.

When you have finished setting, press **MENU** several times to return to previous screens.

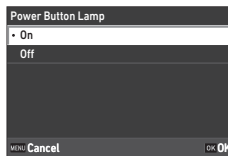

Memo

- When **MENU** is pressed, the last used menu screen appears first. To display the most appropriate menus for the camera settings at that time, set [Store Cursor Position] to [Off] in the 2 menu.
- (control dial) can be turned in place of ▲▼.
- The setting is saved even after the power is turned off. Each menu type can be restored to the default settings in [Reset] of the 11 menu. When the mode dial is set to **U1**, **U2**, or **U3**, [Reset] is not available.



Menu List

The following menus are available. (The underlined settings and the square-bracketed settings are the default settings.)

Still Image Settings Menus

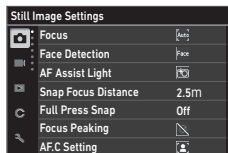

1 Focus Settings

Focus	<u>Auto-area AF</u> , Select AF, Pinpoint AF, Tracking AF, Continuous AF, MF, Snap, ∞	p.57
Face Detection	<u>On</u> , Use only in Auto-area AF, Off	p.58
AF Assist Light	<u>On</u> , Off	p.58
Snap Focus Distance	1m, 1.5m, 2m, <u>2.5m</u> , 5m, ∞	p.57
Full Press Snap	On, <u>Off</u>	p.62
Focus Peaking	Highlight Edge, Extract Edge, <u>Off</u>	p.58
A.F.C Setting	<u>Focus-priority</u> , FPS-priority	p.57
MF Auto Magnification	On, <u>Off</u>	p.60

2 Exposure Setting

Exposure Mode	Program AE, Aperture Priority AE, Shutter Priority AE, Manual Exposure	p.120
AE Metering	<u>Multi-segment</u> , Center-weighted, Spot, Highlight-weighted	p.63
ISO Setting	ISO Setting: <u>ISO AUTO</u> , ISO 100 to ISO 102400 ISO Auto Upper Limit: From one setting higher than the lowest ISO sensitivity to the highest ISO sensitivity [3200] ISO Auto Lower Limit: From the lowest ISO sensitivity to one setting lower than the highest ISO sensitivity [100] Minimum Shutter Speed: 1 to 1/1000 sec. [1/30]	p.64
Flash Mode	Flash Mode: <u>Flash On</u> , Flash On+Red-eye, Slow-speed Sync, Slow Sync+Red-eye Flash Exposure Comp.: -2.0 to +1.0	p.66

Program Line	<u>Normal</u> , Max Aperture Priority	p.50
ND Filter	<u>Auto</u> , On, Off	p.87
Auto EV Compensation	On, <u>Off</u>	p.49
Link AE and AF Point	On, <u>Off</u>	p.63
📷 3 White Balance Settings		
White Balance	Auto White Balance, <u>Multi Auto White Balance</u> , Daylight, Shade, Cloudy, Fl. - Daylight Color, Fl. - Daylight White, Fl. - Cool White, Fl. - Warm White, Tungsten, CTE, Manual White Balance, Color Temperature	p.69
WB Fine-tuning	On, <u>Off</u>	p.71
AWB in Tungsten Light	<u>High</u> , Low	p.71
📷 4 Shooting Settings		
Still/Movie	<u>Still Image</u> , Movie	p.54
Macro Mode	On, <u>Off</u>	p.61
Drive Mode	Drive: <u>Single Frame Shooting</u> , Continuous Shooting, Bracketing, Multi-exposure, Interval Shooting, Interval Composite Self-timer: 10sec., 2sec., <u>Off</u>	p.74
AA Filter Simulator	High, Low, <u>Off</u>	p.87
📷 5 Image Capture Settings		
File Format	<u>JPEG</u> , RAW, RAW+JPEG	p.85
Aspect Ratio	<u>3:2</u> , 1:1	
Crop	35mm, 50mm, <u>Off</u>	
JPEG Recorded Pixels	L, M, S, XS	
Color Space	<u>sRGB</u> , AdobeRGB	

6 Image Process Settings

Image Control	<u>Standard</u> , Vivid, Monotone, Soft Monotone, Hard Monotone, Hi-Contrast B&W, Positive Film, Bleach Bypass, Retro, HDR Tone, Custom1, Custom2	p.88
Peripheral Illumin. Corr.	<u>On</u> , Off	p.90
D-Range Correction	Highlight Correction: <u>Auto</u> , On, Off Shadow Correction: <u>Auto</u> , Low, Medium, High, Off	p.85
Noise Reduction	Slow Shutter Speed NR: <u>Auto</u> , On, Off High-ISO Noise Reduction: <u>Auto</u> , Low, Medium, High, Custom, Off	p.63
7 Shooting Assist		
Shake Reduction	<u>On</u> , Off	p.91
Auto SR Off	<u>Enable Auto SR Off</u> , Disable Auto SR Off	p.91

Movie Settings Menus

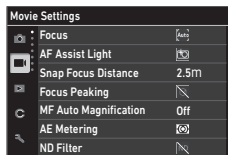

1 Focus Settings

Focus	AF, MF, Snap, ∞	p.57
AF Assist Light	On, Off	p.58
Snap Focus Distance	1m, 1.5m, 2m, 2.5m, 5m, ∞	p.57
Focus Peaking	Highlight Edge, Extract Edge, Off	p.58
MF Auto Magnification	On, Off	p.60

2 Exposure Setting

AE Metering	Multi-segment, Center-weighted, Spot, Highlight-weighted	p.63
ND Filter	On, Off	p.87

3 White Balance Settings

White Balance	Auto White Balance, Daylight, Shade, Cloudy, Fl. - Daylight Color, Fl. - Daylight White, Fl. - Cool White, Fl. - Warm White, Tungsten, CTE, Manual White Balance, Color Temperature	p.69
WB Fine-tuning	On, Off	p.71
AWB in Tungsten Light	High, Low	p.71

4 Shooting Settings

Still/Movie	Still Image, Movie	p.54
Macro Mode	On, Off	p.61

5 Movie Capture Settings

Framerate	60p, 30p, 24p	p.86
Sound Recording	On, Off	

■ 6 Image Process Settings

Image Control	<u>Standard</u> , Vivid, Monotone, Hard Monotone, Hi-Contrast B&W, Positive Film, Bleach Bypass, Retro, Custom1, Custom2	p.88
Peripheral Illumin. Corr.	<u>On</u> , Off	p.90
D-Range Correction	Highlight Correction: <u>Auto</u> , Off Shadow Correction: <u>Auto</u> , Low, Medium, High, Off	p.85

■ 7 Shooting Assist

Movie SR	<u>On</u> , Off	p.91
----------	-----------------	------

▶ Playback Settings Menu

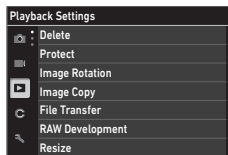

▶ 1 File Management

Delete	Delete 1 Image, Delete All Images	p.97
Protect	Protect 1 Image, Protect All Images	p.98
Image Rotation	90°, 180°, 270°	p.95
Image Copy	—	p.99
File Transfer	Transfer 1 Image	p.100

▶ 2 Image Edit

RAW Development	JPEG Recorded Pixels, Aspect Ratio, Color Space, White Balance, Image Control, Peripheral Illumin. Corr., Sensitivity, High-ISO Noise Reduction, Shadow Correction	p.101
Resize	—	p.103
Cropping	—	p.103
Levels Adjustment	—	p.104
WB Adjustment	—	p.105
Color Moiré Correction	Low, Medium, High	p.106
Base Parameter Adj	Brightness, Saturation, Hue, Contrast, Sharpness	p.107
Movie Edit	Cut, Divide	p.108

▶ 3 Playback Settings

Auto Image Rotation	On, Off	p.95
Playback Order Options	File No., Shooting Date/Time	p.93
Playback Sound Volume	0 to 20 [10]	p.56

C Customize Settings Menus

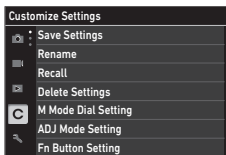

1

Introduction

C 1 User Mode

Save Settings	—	p.117
Rename	—	p.118
Recall	—	p.119
Delete Settings	—	p.118

C 2 Customize Controls





M Mode Dial Setting	Custom1, Custom2	p.52
ADJ Mode Setting	Off, Focus [Setting2], Snap Focus Distance, File Format [Setting3], Aspect Ratio, JPEG Recorded Pixels, AE Metering [Setting4], ISO Setting, Flash Mode, Flash Exposure Comp., Drive, Self-timer, Image Control [Setting1], One Push AE in M Mode, Outdoor View Setting [Setting5]	p.121
Fn Button Setting	Off, Focus, Set MF, Set Snap, Set Tracking AF, Enable AF, AF+AE Lock [Fn Button], AE Lock, Face Detection, Snap Focus Distance, File Format, JPEG → RAW, JPEG → RAW+, Aspect Ratio, Crop, JPEG Recorded Pixels, Framerate, Still/Movie [Movie/Wireless Button], AE Metering, ISO Setting [ISO Button], Flash Mode, Flash Exposure Comp., ND Filter, Drive Mode [Drive Button], Drive, Continuous Shooting, Self-timer, Image Control, Shake Reduction, One Push AE in M Mode, 4-way Controller Action, Outdoor View Setting, Wireless LAN Setting [Hold Movie/Wireless Btn.], Preview Focus Settings: Same as Shutter Button, Auto-area AF, Select AF, Pinpoint AF, Tracking AF, Continuous AF Keep AE Lock: On, Off One Push AE in M Mode: Program AE, Aperture Priority AE, Shutter Priority AE	p.123



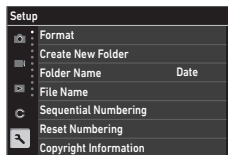

33

Shutter Button Setting	<u>AF+AE Lock</u> , AE Lock	p.125
4-way Controller	<u>Direct Key Priority</u> , AF point change Priority	p.59
Shutter Btn. Confirmation	On, <u>Off</u>	p.125
LCD Touch Operation	On, Off	p.21
Touch AF	<u>AF Point</u> , AF Point+Focus, AF Point+Focus+Shoot, Off	p.50
C 3 Display Customization		
Shooting Info. Display	Standard Info. Display, Simplified Info. Display, No Information Display, Display Off	p.126
Playback Info. Display	Standard Info. Display, No Information Display	
Instant Review	Display Time: <u>0.5sec.</u> , 1sec., 2sec., 3sec., Hold, Off Zoom Review: On, <u>Off</u> Delete: On, <u>Off</u>	p.127
Quick Zoom	x4, x8, x16, <u>100%</u>	p.127
Focus Magnification	On, Off	p.47
Grid Style	<u>3x3 Grid</u> , 4x4 Grid	p.128
Electronic Level Type	<u>Level+Tilt</u> , Level	
Flicker Reduction	<u>50Hz</u> , 60Hz	

Setup Menus



 1 File Setting		
Format	Memory Card, Internal Memory	p.42
Create New Folder	—	p.132
Folder Name	Folder Name: <u>Date</u> , <u>Optional</u> A freely defined string of characters [RICOH]	p.133
File Name	Still Image: A freely defined string of two characters [R0] Movie: A freely defined string of two characters [R0]	p.135
Sequential Numbering	<u>Folder & File</u> , File, Off	p.136
Reset Numbering	—	p.136
Copyright Information	Embed Copyright Data: <u>On</u> , <u>Off</u> Copyright Information: A freely defined string of 32 characters	p.137
 2 Display Settings		
Store Cursor Position	<u>On</u> , Off	p.26
Guide Display	<u>On</u> , Off	p.24
Animation Setting	<u>On</u> , Off	p.47
 3 LCD Setting		
LCD Setting	Brightness: -7 to +7 Saturation: -7 to +7 Adjust: Blue-Amber: -7 to +7 Adjust: Green-Magenta: -7 to +7	p.128
Outdoor View Setting	-2 to +2	p.129
 4 Indicator Lamps		
Power Button Lamp	<u>On</u> , Off	p.129
Count Down	<u>On</u> , Off	
 5 Sound Effects Setting		
Sound Effects	<u>All</u> , Shutter Sound Only	p.130
Volume	0 to 3 [2]	

6 Wireless Connection		
Bluetooth Setting	Action Mode: On anytime, On when power is on, <u>Disable</u> Pairing Communication Info.	p.112
Wireless LAN Setting	Action Mode: On, <u>Off</u> Communication Info.	p.114
Smartphone Link	Store Location Info.: On, <u>Off</u> Auto Image Transfer: On, <u>Off</u> Image Transfer while Off: On, <u>Off</u>	p.113
7 Power Supply Settings		
Auto Power Off	<u>1min.</u> , 3min., 5min., 10min., 30min., Off	p.130
Sleep Mode	<u>1min.</u> , 3min., 5min., 10min., 30min., Off	p.131
LCD Auto Dim	<u>On</u> , Off	
8 About This Device		
Firmware Info/Options	—	—
Certification Marks	—	p.2
9 Sensor Maintenance		
Pixel Mapping	—	p.144
Dust Removal	Execute Dust Removal Startup Action: <u>On</u> , Off Shutdown Action: <u>On</u> , Off	p.144
10 Language/Date Setting		
Language/言語	English, French, German, Spanish, Portuguese, Italian, Dutch, Danish, Swedish, Finnish, Polish, Czech, Hungarian, Turkish, Greek, Russian, Thai, Korean, Traditional Chinese, Simplified Chinese, Japanese	p.41
Date Adjustment	Date Format: Y/M/D, D/M/Y, M/D/Y Date: 1/1/2018 to 12/31/2067 Time: 00:00 to 23:59	p.41
11 Reset		
Reset	Reset Item:  ,  ,  ,  ,  Execute Reset	p.26

Setting the Battery and a Memory Card

Inserting the Battery and a Memory Card

SD memory cards, SDHC memory cards, and SDXC memory cards can be used with this camera. "Memory card" refers to these memory cards in this manual.

- 1** Make sure that the camera power is off.
- 2** Slide the release lever on the bottom of the camera toward OPEN to open the battery/card cover.

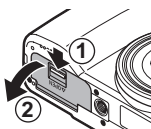

- 3** Make sure that the memory card is facing the right way and then push the card all the way in until it clicks.
To remove it, press in the memory card and then release your hand.

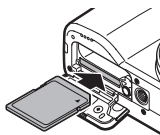

- 4** Insert the battery.
Use the battery to press the latch and insert the battery all the way into the battery compartment.
To remove the battery, slide the latch.

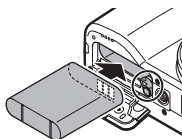

- 5** Close the battery/card cover and slide the release lever in the opposite direction of OPEN to lock it in place.

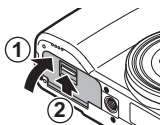

Data Storage Location

Images taken and movies recorded with this camera are saved in the internal memory or a memory card. When a memory card is not inserted in the camera, images and movies are saved in the internal memory.



Caution

- When a memory card is inserted, images and movies are not saved in the internal memory.



Memo

- You can copy all data stored in the internal memory to a memory card. (p.99)
- The storage capacity varies depending on the memory card. (p.152)

Charging the Battery

Charge the rechargeable battery DB-110 using the provided USB cable I-USB166, USB power adapter AC-U1, and power plug before use.

1

Insert the power plug to the USB power adapter.

Insert it until it clicks into place.

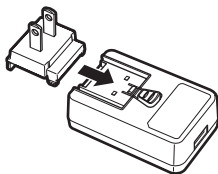

2

Open the terminal cover, and connect the USB cable to the USB terminal.

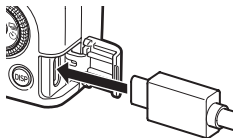

3 Connect the USB cable to the USB power adapter.

4 Plug the USB power adapter into a power outlet.

The status lamp of the camera turns on and charging starts.

Depending on the battery level, the charging time differs. An exhausted battery will be fully recharged in about three hours (at 25°C (77°F)).

When charging is complete, the status lamp turns off. Unplug the USB power adapter from the power outlet.

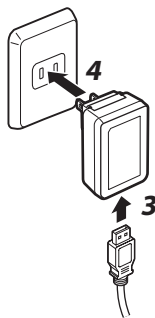

Storage Capacity

- Approximately 320 pictures can be taken when the battery is fully charged.
- This is based on tests conducted according to CIPA standards under the following conditions: At 23°C (73°F) temperature; the picture display is on; a picture is taken every 30 seconds; the camera is turned off and back on after 10 pictures are taken.
- The storage capacity is for reference. For long periods of use, it is recommended that you carry spare batteries.



Caution

- Use only genuine rechargeable battery (DB-110).
- If the battery starts to run down more quickly even after being charged, the battery has reached the end of its service life. In this case, replace the battery with a new one.
- The battery may become very hot immediately after operation. Turn the camera off and leave it to cool down sufficiently before removing the battery.



Memo

- You can also charge the battery by connecting the camera to a computer using the USB cable. An exhausted battery will be fully recharged in approximately 5 hours. (p.110)
- The battery can also be recharged with the optional battery charger BJ-11.

Initial Settings

Turn the camera on and make the initial settings.

Turning the Camera On

2

Getting Started

1 Press the power button.

The power button lamp lights, and then the status lamp blinks for several seconds.

The first time the camera is turned on after purchase, the [Language/言語] screen appears.

When the power button is pressed again, the power turns off.

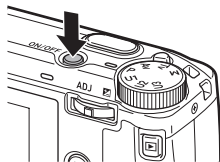

Turning the Camera On in the Playback Mode

- When is pressed and held with the camera turned off, the camera turns on in the playback mode. The following operations are available.

	Turns off the power of the camera.
Press SHUTTER halfway	Switches the camera to the shooting mode.



Turning the Camera On with the Wi-Fi Function Enabled

- When is pressed and held with the camera turned off until a beep sounds, the camera turns on with the Wi-Fi function enabled. (p.115)
- When the Wi-Fi function is enabled using , the camera is not switched to the shooting mode even if **SHUTTER** is pressed. When performing shooting or other operations, press to turn the camera off and press the power button to turn the camera back on.



Memo

- The power button lamp can be set to [Off] in [Power Button Lamp] of the 4 menu. (p.129)
- If no operations are made for approximately one minute, the camera turns off automatically to suppress battery drain. The power saving function can be set in the 7 menu. (p.130)
- The number of images taken on the day (except the deleted images) is displayed when the power is turned off.

Setting the Language and the Date and Time

You can set the display language for menus and the date and time.

- 1 Use ▲▼ to select a language, and press **OK**.
The selected language is set and the [Date Adjustment] screen appears.

- 2 Set the display format and the date and time.

Use ◀▶ to select an item and ▲▼ to change the value.

Press **MENU** to cancel the setting.

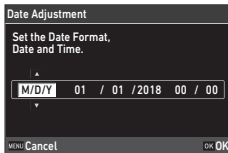

- 3 Press **OK**.

A confirmation screen appears.

- 4 Press **OK**.

The date and time are set and the camera is ready to take a picture.



Memo



- If the battery is removed for about five days, the date and time settings will be lost. To retain the date and time settings, insert a battery with sufficient power for at least two hours, and then remove the battery.
- You can change the language and the date and time settings in the  10 menu.

Formatting a Memory Card

When using a new memory card or a memory card used with another device, be sure to format the memory card with this camera. The internal memory can also be formatted with the same operations.

2

Getting Started

- 1 Press **MENU**.
The menu appears.
- 2 Turn  to select .
The  1 menu appears.

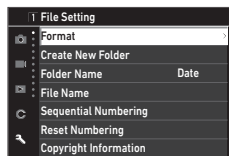

- 3 Select [Format], and press **▶**.
- 4 Use **▲▼** to select [Memory Card] or [Internal Memory], and press **▶**.
The confirmation screen appears.

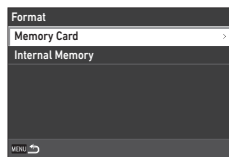

- 5 Use **▲** to select [Execute], and press **OK**.
The memory is formatted and the screen in Step 4 reappears.

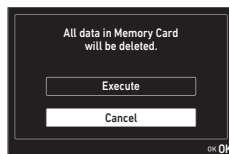

- 6 Press **MENU** twice.
The shooting screen reappears.

**Caution**-----

- Do not remove the memory card while formatting, or the card may be damaged.
- Formatting deletes all data, both protected and unprotected.

**Memo**-----

- When a memory card is formatted, the volume label "GR111" is assigned to the card. When the camera is connected to a computer, it is recognized as a device with the name "GR111".

Basic Shooting Operation

Shooting in the Program Mode

2

Getting Started

- 1** Set the mode dial to **P** while pressing the lock button.

The exposure mode is set to [Program AE] and the Live View is displayed.

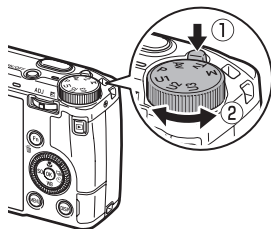

- 2** Press **SHUTTER** halfway.

Focus is adjusted, and exposure is set.

The distance is measured from up to 25 points and the green focus frame appears for the area in focus.



- 3** Press **SHUTTER** fully.

The image you have just taken is displayed on the picture display (Instant Review) and saved.



Focus

- The status lamp and the frame color show whether the subject is in focus.

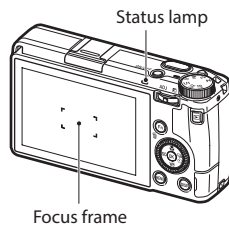



Focus Status	Frame Color	Status Lamp
Before focusing	White	Off
Subject in focus	Green	Green (on)
Unable to focus	Red	Green (blinks)

44



Magnifying Live View image

- The Live View image can be magnified.
The following operations are available.

Press and hold DISP / Double-tap	Magnifies the Live View image.
	Switches the magnification between [x4] and [x16].
  /Slide	Moves the magnified area.
OK	Resets to the entire image display.

- The image cannot be magnified during recording in **■** mode.



Memo

- You can set the display and operation of [Instant Review] that displays the captured image immediately after shooting in the **C** 3 menu. (p.127)

Viewing the Captured Images

Review the captured image on the monitor.

1 Press **▶**.

The camera switches to the playback mode and the last image you took is displayed. (Single image display)

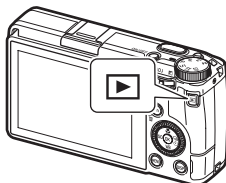

2

Getting Started

2 View an image.



The following operations are available.

/ Flick	Displays the previous or next image.
	Deletes the image.
to the right / Pinch out / Double-tap	Magnifies the image.
to the left / Pinch in / Double-tap	In magnified view: Reduces the image.
/ Slide	In magnified view: Moves the magnified area.
Press ADJ	Magnifies the image with the magnification ([x4], [x8], [x16], [100%]) set in [Quick Zoom] of the C 3 menu. (p.127) Press OK to return to the single image display.
ADJ to the left or right /	In magnified view: Displays the previous or next image without changing the magnification.
DISP	Switches between [Standard Info. Display], [Detailed Info. Display], and [No Information Display]. In magnified view: Switches between [Standard Info. Display] and [No Information Display].
	Displays the playback functions setting screen. (p.92)



Memo

- If [Focus Magnification] is set to [On] (default setting) in the **C** 3 menu, the image is magnified centering on the AF point set in shooting.
- Movies cannot be magnified.
- If the image is switched to the previous or next image using ◀▶, animation is displayed. The function can be set to [Off] in [Animation Setting] of the **3** menu.

Taking Pictures

Taking Still Pictures

Setting the Exposure Mode

Set an aperture value or shutter speed for shooting. The following settings can be set.

✓ : Available # : Conditionally available

Exposure Mode	Aperture Value	Shutter Speed	Sensitivity
P Program AE	#*1	#*1	✓
Av Aperture Priority AE	✓	Automatically set	✓
Tv Shutter Priority AE	Automatically set	✓	✓
M Manual Exposure	✓	✓	✓

*1 The Program Shift allows you to select the combination of aperture value and shutter speed.

1 Set the mode dial to **P**, **Av**, **Tv**, or **M**.

The exposure mode and set value are displayed on the shooting screen.

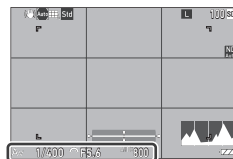



In **M** mode, the exposure indicator is displayed.

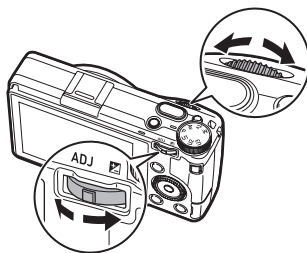

2 Turn or **ADJ** to change a value.



The following settings can be changed.



Exposure Mode		Turn ADJ to the Left or Right ()
P	Program shift	Exposure compensation
Av	Aperture value	Exposure compensation
Tv	Shutter speed	Exposure compensation
M	Aperture value	Shutter speed

In **M** mode, the exposure compensation value can be adjusted using  when ISO AUTO is set. The exposure is correct when the indicator is in the center. When the exposure value is in the range of ± 2 EV, the indicator changes according to the exposure value. The indicator turns red when the values are outside this range.

3 Shoot.



Memo

- If [Auto EV Compensation] is set to [On] in the  2 menu, the exposure is automatically compensated when the correct exposure cannot be achieved in **Av** or **Tv** mode.
- Pressing **SHUTTER** halfway activates the autofocus and AE Lock. To activate only the AE Lock, set [Shutter Button Setting] to [AE Lock] in the  2 menu. (p.125)



Caution

- When a slow shutter speed has been set, images are not displayed on the picture display during shooting.



AE Lock

- The exposure value is locked while **SHUTTER** is pressed halfway, and the lock is canceled when the button is released.
- [AF+AE Lock] or [AE Lock] can be registered to [Fn Button Setting] in the **C** 2 menu to use the function with **Fn**. By default, [AF+AE Lock] is assigned to **Fn**. (p.123)

AF+AE Lock	Locks the focus and exposure value. The lock is canceled when the button is released.
AE Lock	When [Keep AE Lock] is set to [On] in [Fn Button Setting] of the C 2 menu, the AE lock is kept if the button is released.

- The AE lock function is not available if the sensitivity is fixed at a certain sensitivity when in **M** mode, or if the shutter speed is set to [B], [T], or [BT].



AF Using the Touch Panel

- By default, only the AF point can be changed using the touch panel. To perform autofocus and shooting using the touch panel, set [Touch AF] in the **C** 2 menu.

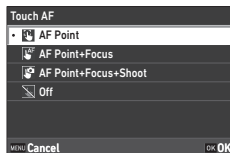

AF Point	Sets the AF point to the touched point.
AF Point+Focus	Sets the AF point to the touched point and activates [Select AF].
AF Point+Focus+Shoot	Sets the AF point to the touched point, activates [Select AF], and shoots.
Off	Does not use Touch AF.



Program Line

- You can set the program line for **P** mode to [Max Aperture Priority] in [Program Line] of the **C** 2 menu.



Bulb, Time, and Bulb Timer

- In **M** mode, [B], [T], or [BT] can be set for the shutter speed.



Shutter Speed	Operation
B Bulb	Exposure is continued while SHUTTER is pressed, and canceled when the button is released.
T Time	Exposure is started when SHUTTER is pressed, and ended when the button is pressed again.
BT Bulb timer	Exposure is started when SHUTTER is pressed, and ended after the set time has elapsed. Set the exposure time using  .

- [B] and [T] are available when [Drive Mode] is set to [Single Frame Shooting] or [Multi-exposure], and [BT] is available when [Drive Mode] is set to [Single Frame Shooting], [Multi-exposure], [Interval Shooting], or [Interval Composite].
- Operation is also possible using the optional cable switch (CA-2) in place of **SHUTTER**.
- [One Push AE in M Mode] in [Fn Button Setting] of the **C 2** menu does not work.



Preview

- When [Hold Movie/Wireless Btn.] is set to [Preview] in [Fn Button Setting] of the **C 2** menu, the Preview is available using the button. (p.123) If you press and hold when the aperture value is displayed on the shooting screen (such as when **SHUTTER** is pressed halfway), the aperture is adjusted to the set aperture value, and you can check the depth of field. It is canceled when is released.
- When [Hold Movie/Wireless Btn.] is set to [Wireless LAN Setting] (default setting), works as the switch to turn on/off the wireless LAN function. In this case, the Preview is not available.
- In the Preview mode, **SHUTTER** cannot be pressed fully, and the aperture value cannot be changed.
- When using the flash, the actual aperture value may differ from the Preview.
- The Preview is used for checking the depth of field, so it may not function properly with AE.
- This function is not available in **M** mode.



Functions in **M** Mode

- The functions for and **ADJ** when in **M** mode can be switched in [M Mode Dial Setting] of the **C 2** menu.
- When [One Push AE in M Mode] is registered in [Fn Button Setting] (p.123) of the **C 2** menu, you can select the priority of values for when the button is pressed,.

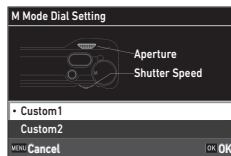

Program AE	Adjusts both the aperture value and shutter speed.
Aperture Priority AE	Sets the aperture value to a fixed value and adjusts the shutter speed.
Shutter Priority AE	Sets the shutter speed to a fixed value and adjusts the aperture value.

When ISO AUTO is set, [One Push AE in M Mode] does not work.

Using Exposure Compensation

1 Press **ADJ** () to the left or right.

The value will be plus (+) when the button is pressed to the right, and minus (-) when it is pressed to the left.

In **M** mode, turn .

Settings can be made in the range of ± 5.0 EV (± 2.0 EV in **Av** mode) in increments of 1/3 EV steps.

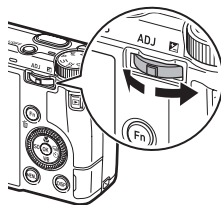

Caution

- Exposure compensation is not available when the sensitivity is fixed at a certain sensitivity in **M** mode.