

# Test Report of FCC CFR 47 Part 15 Subpart C

On Behalf of

## Hasen Technology Co., Limited.

**FCC ID:** 2ACZ5-HS809  
**Product Description:** Bluetooth Speaker  
**Model No.:** HS-809  
**Supplementary Model:** HS-805, HS-801 ~ HS-850

**Prepared for:** Hasen Technology Co., Limited.

Humen Town, Dongguan City, Guangdong Province, China

**Prepared by:** Shenzhen Bontek Compliance Testing Laboratory Co., Ltd.

1/F, Block East H-3, OCT Eastern Ind. Zone, Qiaocheng East Road, Nanshan, Shenzhen, China

Tel: 86-755-86337020

Fax: 86-755-86337028

**Report No.:** BCT14GR271E

**Issue Date:** July31, 2014

**Test Date:** July 4 ~10 , 2014

**Tested by:**



Jiankuai.Li

**Reviewed by:**



Lv yi

**Approved by:**



Owen Yang

## TABLE OF CONTENTS

<b>1. GENERAL INFORMATION</b> .....	<b>4</b>
1.1 PRODUCT DESCRIPTION FOR EQUIPMENT UNDER TEST (EUT).....	4
1.2 RELATED SUBMITTAL(S) / GRANT (S) AND TEST METHODOLOGY.....	5
1.3 TEST FACILITY.....	5
<b>2. SYSTEM TEST CONFIGURATION</b> .....	<b>6</b>
2.1 EUT CONFIGURATION.....	6
2.2 EUT EXERCISE.....	6
2.3 GENERAL TEST PROCEDURES.....	6
2.4 MEASUREMENT UNCERTAINTY.....	6
2.5 SUPPORT EQUIPMENTS.....	6
2.6 TEST EQUIPMENT LIST AND DETAILS.....	7
<b>3. SUMMARY OF TEST RESULTS</b> .....	<b>7</b>
<b>4. TEST OF AC POWER LINE CONDUCTED EMISSION</b> .....	<b>8</b>
4.1 APPLICABLE STANDARD.....	8
4.2 TEST SETUP DIAGRAM.....	8
4.3 TEST RESULT.....	8
<b>5. TEST OF HOPPING CHANNEL BANDWIDTH</b> .....	<b>11</b>
5.1 APPLICABLE STANDARD.....	11
5.2 EUT SETUP.....	11
5.3 TEST EQUIPMENT LIST AND DETAILS.....	11
5.4 TEST PROCEDURE.....	11
5.5 TEST RESULT.....	11
<b>6. TEST OF HOPPING CHANNEL SEPARATION</b> .....	<b>16</b>
6.1 APPLICABLE STANDARD.....	16
6.2 EUT SETUP.....	16
6.3 TEST EQUIPMENT LIST AND DETAILS.....	16
6.4 TEST PROCEDURE.....	16
6.5 TEST RESULT.....	16
<b>7. TEST OF NUMBER OF HOPPING FREQUENCY</b> .....	<b>21</b>
7.1 APPLICABLE STANDARD.....	21
7.2 EUT SETUP.....	21
7.3 TEST EQUIPMENT LIST AND DETAILS.....	21
7.4 TEST PROCEDURE.....	21
7.5 TEST RESULT.....	21
<b>8. TEST OF DWELL TIME OF EACH FREQUENCY</b> .....	<b>23</b>
8.1 APPLICABLE STANDARD.....	23
8.2 EUT SETUP.....	23
8.3 TEST EQUIPMENT LIST AND DETAILS.....	23
8.4 TEST PROCEDURE.....	23
8.5 TEST RESULT.....	23
<b>9. TEST OF MAXIMUM PEAK OUTPUT POWER</b> .....	<b>28</b>
9.1 APPLICABLE STANDARD.....	28
9.2 EUT SETUP.....	28
9.3 TEST EQUIPMENT LIST AND DETAILS.....	28
9.4 TEST PROCEDURE.....	28
9.5 TEST RESULT.....	28
<b>10. TEST OF BAND EDGES EMISSION</b> .....	<b>33</b>
10.1 APPLICABLE STANDARD.....	33
10.2 EUT SETUP.....	33
10.3 TEST EQUIPMENT LIST AND DETAILS.....	33
10.4 TEST PROCEDURE.....	33
10.5 TEST RESULT.....	34

<b>11. TEST OF SPURIOUS RADIATED EMISSION .....</b>	<b>38</b>
11.1 APPLICABLE STANDARD .....	38
11.2 EUT SETUP .....	38
11.3 TEST EQUIPMENT LIST AND DETAILS .....	39
11.4 TEST PROCEDURE .....	39
11.5 TEST RESULT .....	40
<b>12. ANTENNA REQUIREMENT .....</b>	<b>54</b>
12.1 STANDARD APPLICABLE .....	54
12.2 ANTENNA CONNECTED CONSTRUCTION .....	54

# 1. GENERAL INFORMATION

## 1.1 Product Description for Equipment Under Test (EUT)

### Client Information

Applicant:	<b>Hasen Technology Co., Limited.</b>
Address of applicant:	Humen Town, Dongguan City, Guangdong Province, China
Manufacturer :	<b>Hasen Technology Co., Limited.</b>
Address of manufacturer:	Humen Town, Dongguan City, Guangdong Province, China

### General Description of E.U.T

Items	Description
EUT Description:	Bluetooth Speaker
Model No.:	HS-809
Trade Name:	N/A
Supplementary Model:	HS-805, HS-801 ~ HS-850
BT Module	BT2.1+ EDR
Frequency Band:	2402~2480MHz
Number of Channels:	79
Type of Modulation:	GFSK, Pi/4 DQPSK
Antenna Gain	0 dBi
Antenna Type:	Integral Antenna
Rated Voltage:	Battery 3.7V,750mAh,DC 5V from PC
Adapter information:	N/A

Remark: \* *The test data gathered are from the production sample provided by the manufacturer.*  
\* *Supplementary models have the same circuit, but with different appearance*

## **1.2 Related Submittal(s) / Grant (s) and Test Methodology**

The tests were performed based on the Electromagnetic Interference (EMI) tests performed on the EUT. Both conducted and radiated testing were performed according to the procedures in ANSI C63.4 - 2003 Radiated testing was performed at an antenna to EUT distance 3 meters.

The tests were performed in order to determine compliance with FCC Part 15, Subpart C, and section 15.203, 15.207, 15.209 and 15.247 rules. Test was carried out according to the above mentioned FCC rules and the FCC publication notice DA 00-705: Filing and Measurement Guidelines for Frequency Hopping Spread Spectrum Systems

## **1.3 Test Facility**

All measurement required was performed at laboratory of Shenzhen CTL Testing Technology Co., Ltd. at Floor 1-A, Baisha Technology Park, No.3011, Shahexi Road, Nanshan District, Shenzhen, China 518055.

The test facility is recognized, certified, or accredited by the following organizations:

### **FCC – Registration No.: 970318**

Shenzhen CTL Testing Technology Co., Ltd. EMC Laboratory has been registered and fully described in a report filed with the (FCC) Federal Communications Commission. The acceptance letter from the FCC is maintained in our files. Registration 970318, December, 2013.

## 2. SYSTEM TEST CONFIGURATION

### 2.1 EUT Configuration

The EUT configuration for testing is installed on RF field strength measurement to meet the Commissions requirement and operating in a manner that intends to maximize its emission characteristics in a continuous normal application.

### 2.2 EUT Exercise

The calibrated antennas used to sample the radiated field strength are mounted on a non-conductive, motorized antenna mast 3 or 10 meters from the leading edge of the turntable.

### 2.3 General Test Procedures

**Conducted Emissions:** The EUT is placed on the turntable, which is 0.8 m above ground plane. According to the requirements in Section 7.1 of ANSI C63.4-2003 Conducted emissions from the EUT measured in the frequency range between 0.15 MHz and 30MHz using CISPR Quasi-Peak detector mode.

**Radiated Emissions:** The EUT is a placed on as turntable, which is 0.8 m above ground plane. The turntable shall rotate 360 degrees to determine the position of maximum emission level. EUT is set 3m away from the receiving antenna, which varied from 1m to 4m to find out the highest emission. And also, each emission was to be maximized by changing the polarization of receiving antenna both horizontal and vertical. In order to find out the maximum emissions, exploratory radiated emission measurements were made according to the requirements in Section 13.1.4.1 of ANSI C63.4-2003.

### 2.4 Measurement Uncertainty

Where relevant, the following measurement uncertainty levels have been estimated for tests performed on the apparatus:

Parameter	Uncertainty
Power Line Conducted Emission	+/- 2.3 dB
Radiated Emission	+/- 3.4 dB

Uncertainty figures are valid to a confidence level of 95%.

### 2.5 Support Equipments

The calibrated antennas used to sample the radiated field strength are mounted on a non-conductive, motorized antenna mast 3 or 10 meters from the leading edge of the turntable.

## 2.6 Test Equipment List and Details

Test equipments list of Shenzhen CTL Testing Technology Co., Ltd.

No.	Instrument no.	Equipment	Manufacturer	Model No.	S/N	Last Calculator	Due Calculator
1	BCT-EMC001	EMI Test Receiver	R&S	ESCI	100687	2014-4-25	2015-4-24
2	BCT-EMC002	EMI Test Receiver	R&S	ESPI	100097	2013-11-1	2014-10-31
3	BCT-EMC003	Amplifier	HP	8447D	1937A02492	2014-4-25	2015-4-24
4	BCT-EMC018	TRILOG Broadband Test- Antenna	SCHWARZBECK	VULB9163	9163-324	2014-4-25	2015-4-24
5	BCT-EMC021	Triple-Loop Antenna	EVERFINE	LLA-2	711002	2013-11-1	2014-10-31
6	BCT-EMC026	RF POWER AMPLIFIER	FRANKONIA	FLL-75	1020A1109	2014-4-25	2015-4-24
7	BCT-EMC029	6DB Attenuator	FRANKONIA	N/A	1001698	2014-4-25	2015-4-24
8	BCT-EMC032	10dB attenuator	ELECTRO- METRICS	EM-7600	836	2014-4-25	2015-4-24
9	BCT-EMC036	Spectrum Analyzer	R&S	FSP	100397	2013-11-1	2014-10-31
10	BCT-EMC037	Broadband preamplifier	SCH WARZBECK	BBV9718	9718-182	2014-4-25	2015-4-24
11	BCT-EMC039	Horn Antenna	SCHWARZBECK	BBHA 9120D	0437	2014-4-25	2015-4-24
12	BCT-EMC038	Horn Antenna	SCHWARZBECK	BBHA9170	0483	2014-4-25	2015-4-24

## 3. SUMMARY OF TEST RESULTS

FCC Rules	Description of Test	Result
FCC §15.207	AC Power Line Conducted Emission	Pass
FCC §15.247(a)(1)	Hopping Channel Bandwidth	Pass
FCC §15.247(a)(1)	Hopping Channel Separation	Pass
FCC §15.247(a)(1)	Number of Hopping Frequency Used	Pass
FCC §15.247(a)(1)(iii)	Dwell Time of Each Frequency	Pass
FCC §15.247(b)(1)	Maximum Peak Output Power	Pass
FCC §15.247(d)	Band Edges Emission	Pass
FCC §15.247(d)	Spurious Radiated Emission	Pass
FCC §15.203/15.247(b)/(c)	Antenna Requirement	Pass

## 4. TEST OF AC POWER LINE CONDUCTED EMISSION

### 4.1 Applicable standard

Refer to FCC §15.207.

For a Low-power Radio-frequency Device is designed to be connected to the AC power line, the radio frequency voltage that is conducted back onto the AC power line on any frequency or frequencies within the band 150 kHz to 30 MHz shall not exceed below limits table.

Frequency Range (MHz)	Limits ( dBuV)	
	Quasi-Peak	Average
0.150~0.500	66~56	56~46
0.500~5.000	56	46
5.000~30.00	60	50

### 4.2 Test Setup Diagram

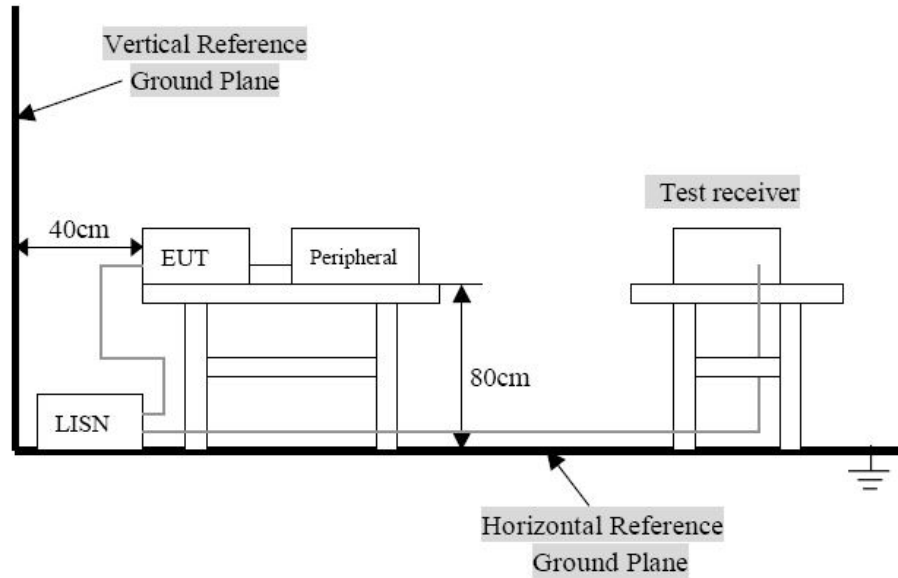

Remark: The EUT was connected to a 120 VAC/ 60Hz power source.

### 4.3 Test Result

Temperature ( °C ) : 23~25	EUT: Bluetooth Speaker
Humidity (%RH) : 45~58	M/N: HS-809
Barometric Pressure ( mbar ) : 950~1000	Operation Condition: Tx Mode



**Conducted Emission:**

EUT: Bluetooth Speaker  
M/N: HS-809  
Operating Condition: Tx Mode  
Test Site: Shielded Room  
Operator: Yang  
Test Specification: AC 120V/60Hz for adapter  
Comment: L Line

**SCAN TABLE: "Voltage (150K-30M) FIN"**  
Short Description: 150K-30M Voltage

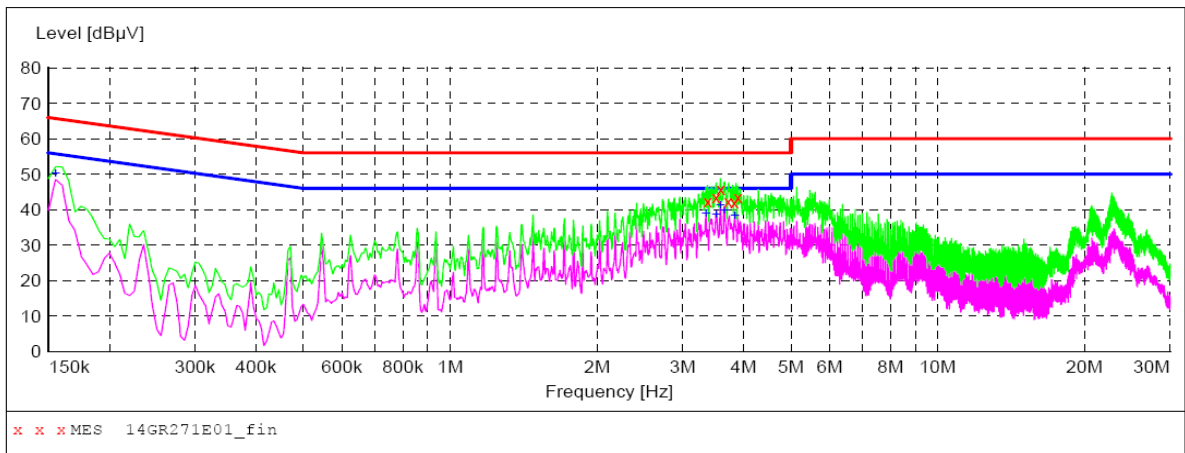

**MEASUREMENT RESULT: "14GR271E01\_fin"**

7/7/2014 09:51

Frequency MHz	Level dBµV	Transd dB	Limit dBµV	Margin dB	Detector	Line	PE
3.375000	42.50	10.4	56	13.5	QP	L1	GND
3.515000	43.70	10.4	56	12.3	QP	L1	GND
3.585000	46.00	10.4	56	10.0	QP	L1	GND
3.715000	42.50	10.4	56	13.5	QP	L1	GND
3.830000	42.10	10.4	56	13.9	QP	L1	GND
3.895000	43.60	10.4	56	12.4	QP	L1	GND

**MEASUREMENT RESULT: "14GR271E01\_fin2"**

7/7/2014 09:51

Frequency MHz	Level dBµV	Transd dB	Limit dBµV	Margin dB	Detector	Line	PE
0.155000	50.30	13.2	56	5.4	AV	L1	GND
3.350000	38.90	10.4	46	7.1	AV	L1	GND
3.515000	38.60	10.4	46	7.4	AV	L1	GND
3.585000	41.40	10.4	46	4.6	AV	L1	GND
3.655000	39.70	10.4	46	6.3	AV	L1	GND
3.840000	38.40	10.4	46	7.6	AV	L1	GND

**Conducted Emission:**

EUT: Bluetooth Speaker  
 M/N: HS-809  
 Operating Condition: Tx Mode  
 Test Site: Shielded Room  
 Operator: Yang  
 Test Specification: AC 120V/60Hz for adapter  
 Comment: N Line

**SCAN TABLE: "Voltage (150K-30M) FIN"**  
 Short Description: 150K-30M Voltage

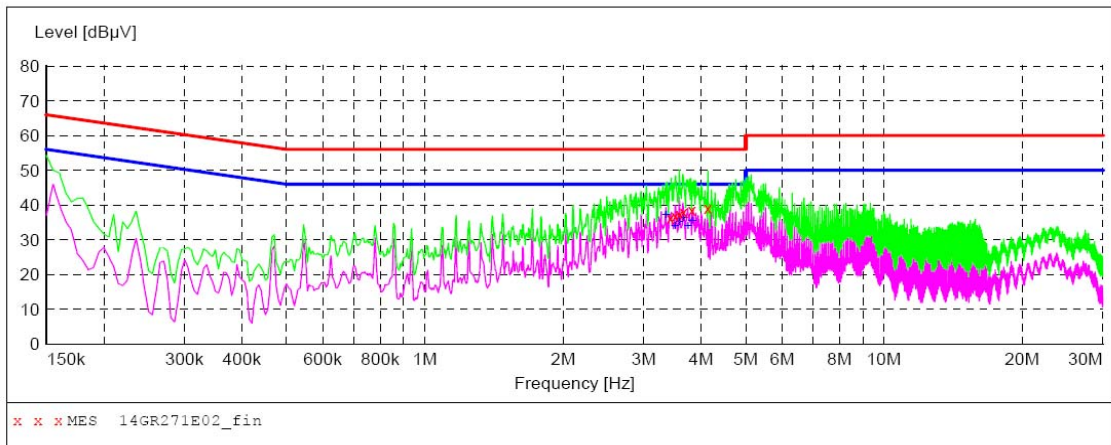

**MEASUREMENT RESULT: "14GR271E02\_fin"**

7/7/2014 09:54

Frequency MHz	Level dBµV	Transd dB	Limit dBµV	Margin dB	Detector	Line	PE
3.430000	36.20	10.4	56	19.8	QP	N	GND
3.510000	36.80	10.4	56	19.2	QP	N	GND
3.585000	37.60	10.4	56	18.4	QP	N	GND
3.665000	38.00	10.4	56	18.0	QP	N	GND
3.820000	38.70	10.4	56	17.3	QP	N	GND
4.135000	39.20	10.4	56	16.8	QP	N	GND

**MEASUREMENT RESULT: "14GR271E02\_fin2"**

7/7/2014 09:54

Frequency MHz	Level dBµV	Transd dB	Limit dBµV	Margin dB	Detector	Line	PE
3.355000	37.10	10.4	46	8.9	AV	N	GND
3.510000	33.90	10.4	46	12.1	AV	N	GND
3.585000	35.10	10.4	46	10.9	AV	N	GND
3.665000	36.20	10.4	46	9.8	AV	N	GND
3.745000	34.00	10.4	46	12.0	AV	N	GND
3.820000	35.40	10.4	46	10.6	AV	N	GND

## 5. Test of Hopping Channel Bandwidth

### 5.1 Applicable standard

Section 15.247(a)(1): Frequency hopping systems shall have hopping channel carrier frequencies separated by a minimum of 25 kHz or the 20 dB bandwidth of the hopping channel, whichever is greater.

### 5.2 EUT Setup

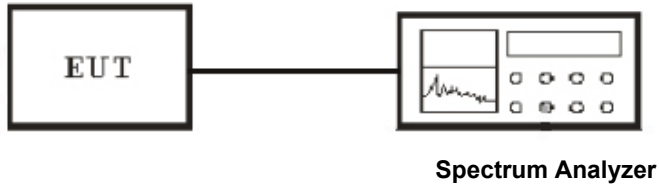

### 5.3 Test Equipment List and Details

See section 2.5.

### 5.4 Test Procedure

1. The transmitter output was connected to the spectrum analyzer through an attenuator.
2. Use the following spectrum analyzer settings:
  - Span = approximately 2 to 3 times the 20 dB bandwidth, centered on a hopping channel
  - RBW  $\geq$  1% of the 20 dB bandwidth, VBW  $\geq$  RBW
  - Sweep = auto
  - Detector function = peak
  - Trace = max hold
3. The spectrum width with level higher than 20dB below the peak level.
4. Repeat above 1~3 points for the middle and highest channel of the EUT.

### 5.5 Test Result

Temperature ( °C ) : 22~23	EUT: Bluetooth Speaker
Humidity (%RH ) : 50~54	M/N: HS-809
Barometric Pressure ( mbar ) : 950~1000	Operation Condition: Tx Mode

**BDR 1M**

Modulation Type	Channel No.	Frequency (MHz)	20dB Bandwidth (kHz)
GFSK	Low	2402.00	912
GFSK	Middle	2441.00	924
GFSK	High	2480.00	924

**EDR 2M**

Modulation Type	Channel No.	Frequency (MHz)	20dB Bandwidth (kHz)
Pi/4 DQPSK	Low	2402.00	1224
Pi/4 DQPSK	Middle	2441.00	1220
Pi/4 DQPSK	High	2480.00	1220

**BDR 1M  
Channel Low**

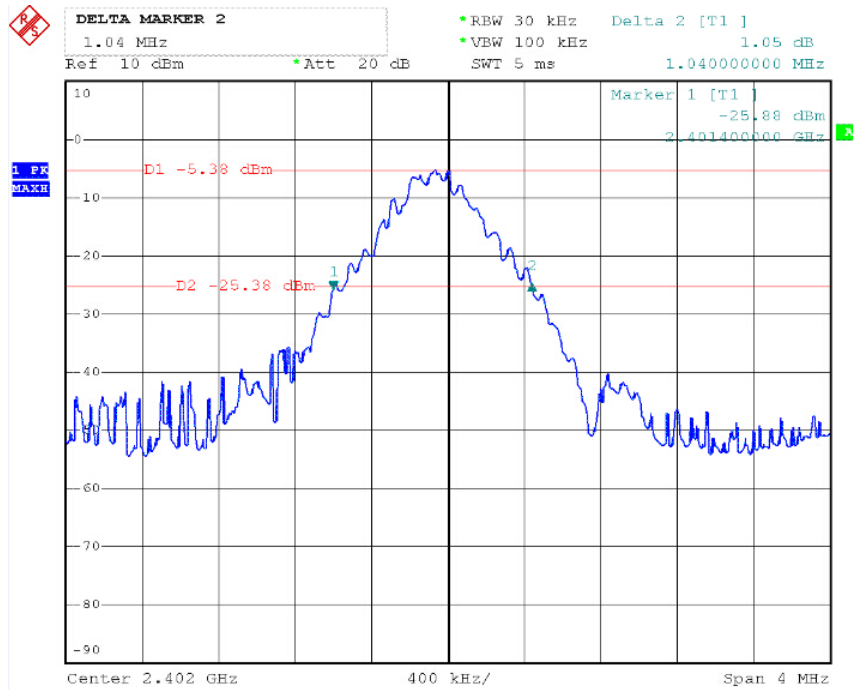

### Channel Middle

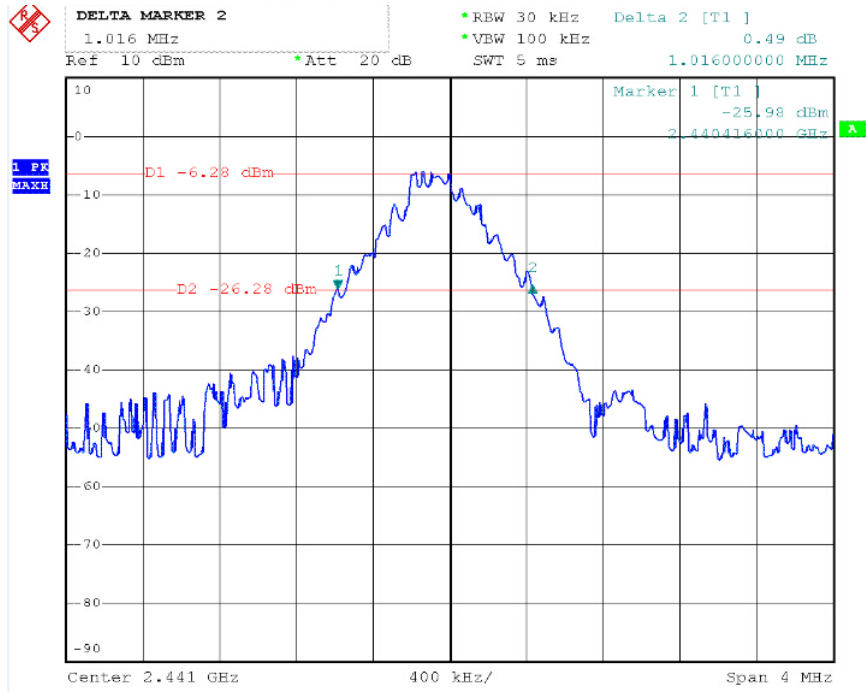

### Channel High

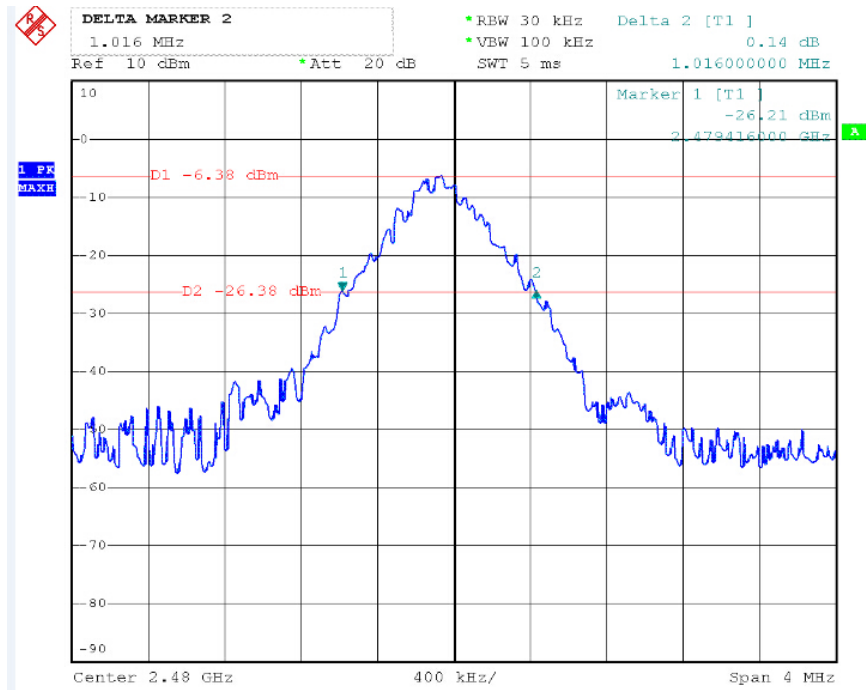

**EDR 2M  
Channel Low**

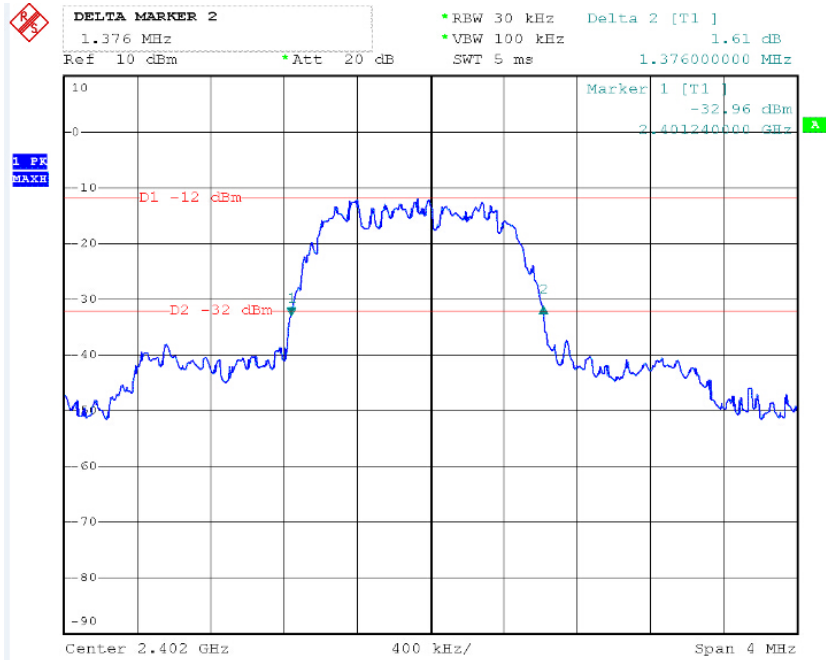

**Channel Middle**

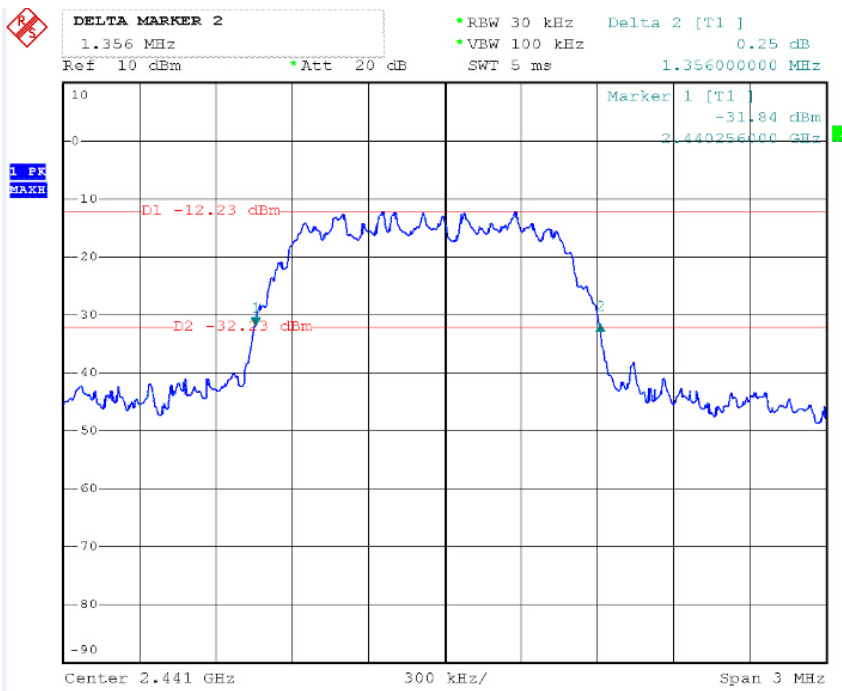

# Channel High

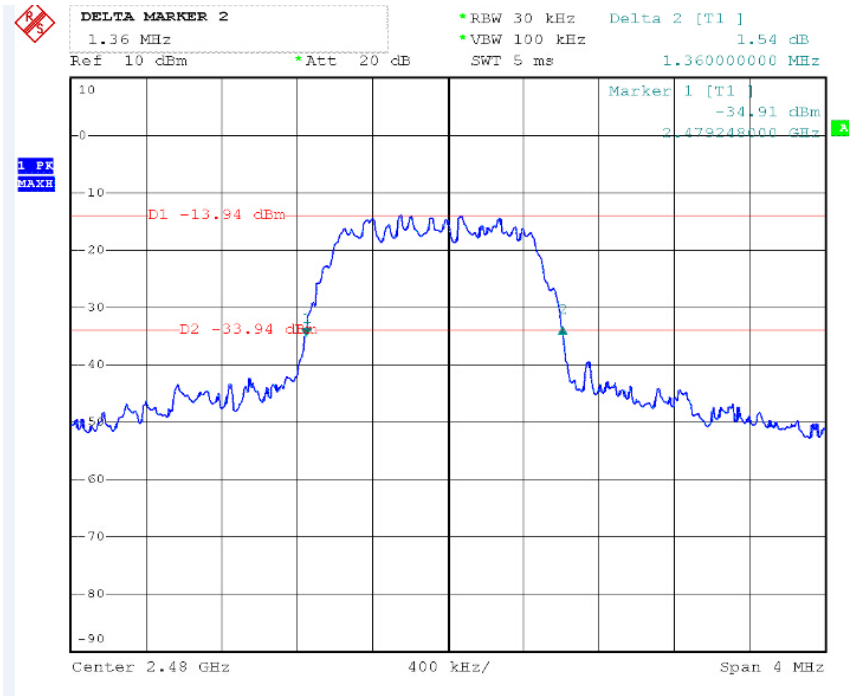

## 6. Test of Hopping Channel Separation

### 6.1 Applicable standard

Section 15.247(a)(1): Frequency hopping systems shall have hopping channel carrier frequencies separated by a minimum of 25 kHz or the 20 dB bandwidth of the hopping channel, whichever is greater.

### 6.2 EUT Setup

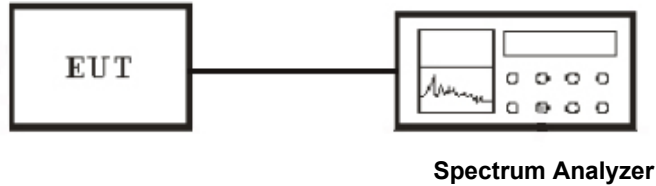

### 6.3 Test Equipment List and Details

See section 2.5.

### 6.4 Test Procedure

1. The transmitter output was connected to the spectrum analyzer through an attenuator.
2. Set RBW of spectrum analyzer to 30KHz and VBW to 100KHz.
3. Set Detector to Peak, Trace to Max Hold and Sweep Time is Auto.
4. The Hopping Channel Separation is defined as the separation between 2 neighboring hopping frequencies.
5. Repeat above 1~3 points for the middle and highest channel of the EUT.

### 6.5 Test Result

Temperature ( °C ): 22~23	EUT: Bluetooth Speaker
Humidity (%RH ): 50~54	M/N: HS-809
Barometric Pressure ( mbar ): 950~1000	Operation Condition: Tx Mode



**BDR 1M**

<b>Modulation Type</b>	<b>Frequency (MHz)</b>	<b>Channel Separation (MHz)</b>	<b>Min. Limit (kHz)</b>
GFSK	2402~2403	1.015	>25
GFSK	2441~2442	1.016	>25
GFSK	2479~2480	1.020	>25

**EDR 2M**

<b>Modulation Type</b>	<b>Frequency (MHz)</b>	<b>Channel Separation (MHz)</b>	<b>Min. Limit (kHz)</b>
Pi/4 DQPSK	2402~2403	1.012	>25
Pi/4 DQPSK	2441~2442	1.012	>25
Pi/4 DQPSK	2479~2480	1.000	>25

**BDR 1M  
Channel Low**

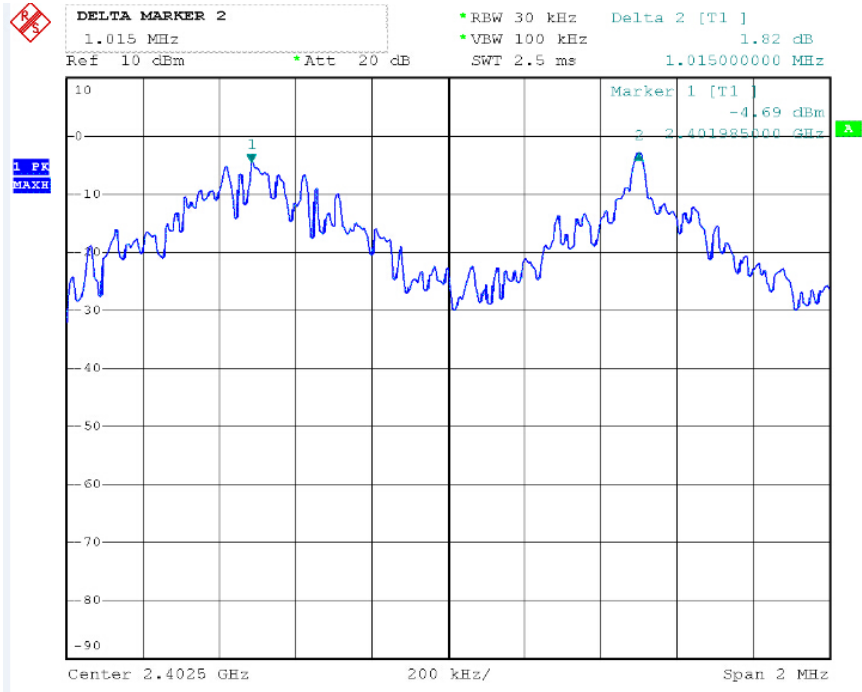

**Channel Middle**

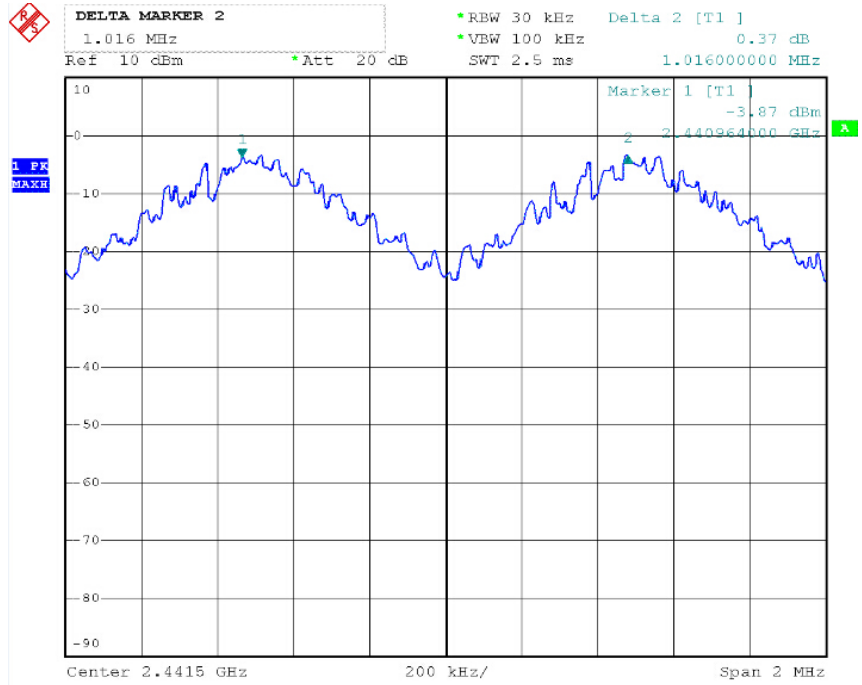

### Channel High

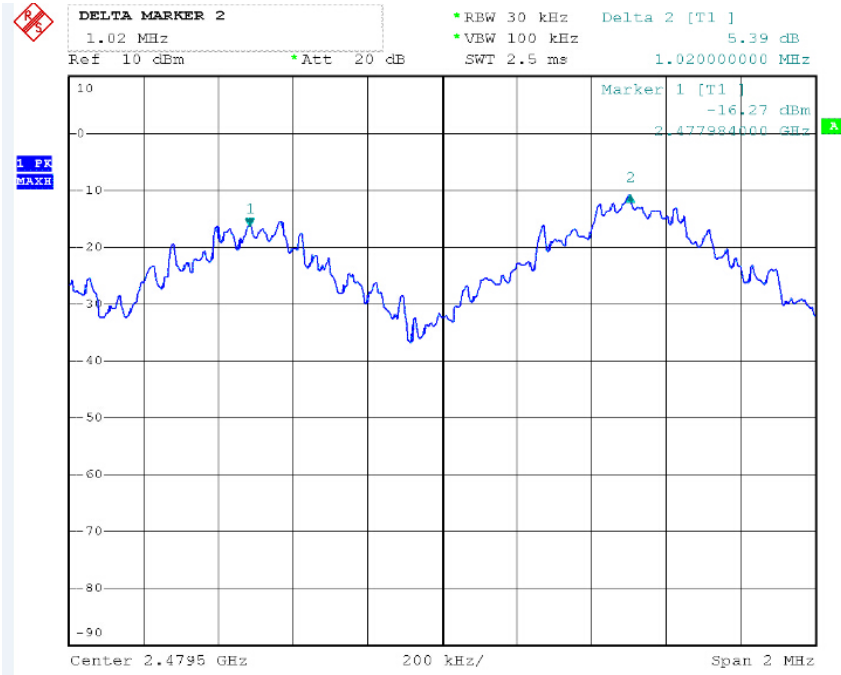

### EDR 2M Channel Low

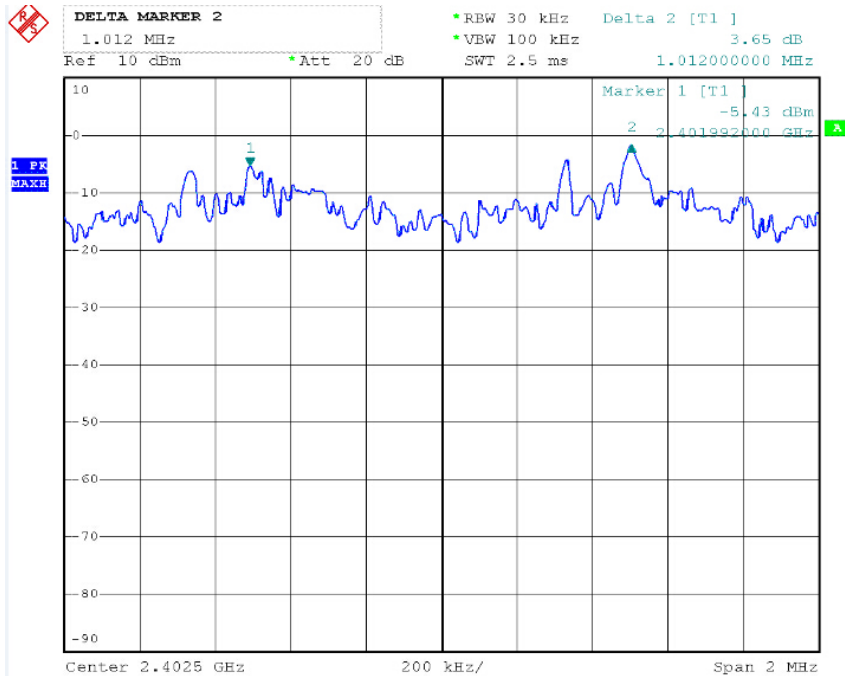

### Channel Middle

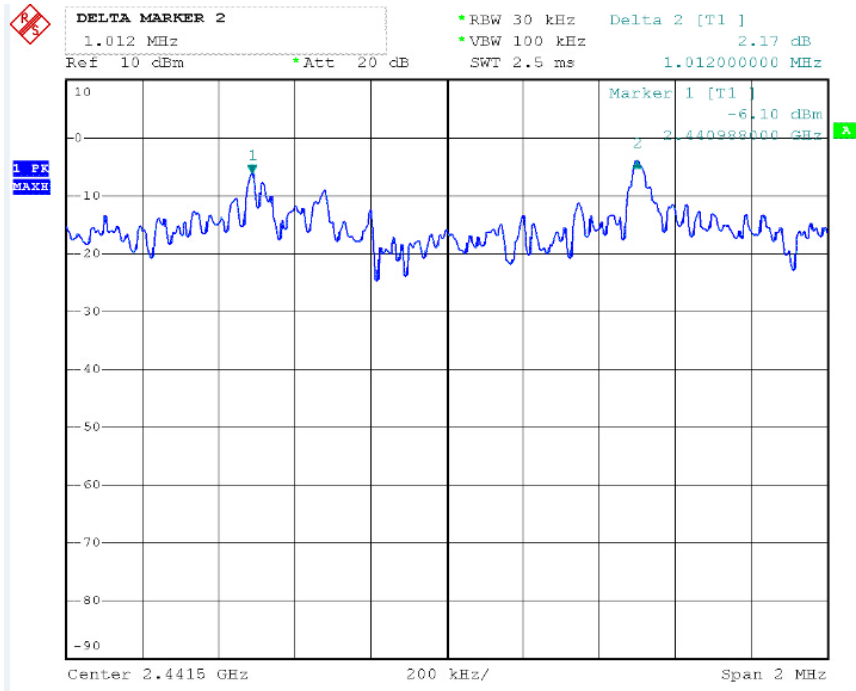

### Channel High

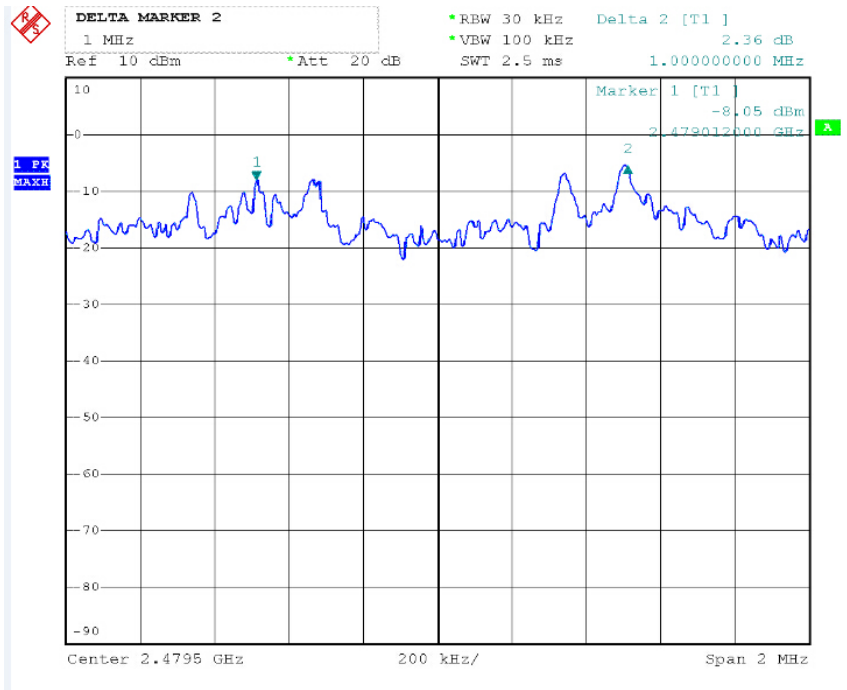

## 7. Test of Number of Hopping Frequency

### 7.1 Applicable standard

Section 15.247(a)(1)(iii): For frequency hopping systems operating in the 2400-2483.5 MHz band employing at least 15 non-overlapping hopping channels. Frequency hopping system which use fewer than 75 hopping frequencies may employ intelligent hopping techniques to avoid interference to other transmissions. Frequency hopping system may avoid or suppress transmissions on a particular hopping frequency provided that a minimum of 15 non-overlapping channels are used.

### 7.2 EUT Setup

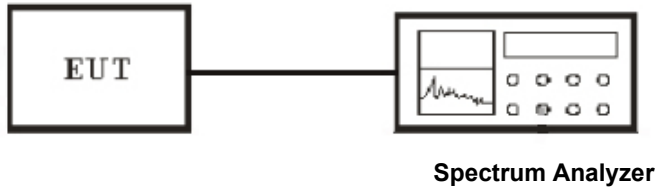

### 7.3 Test Equipment List and Details

See section 2.5.

### 7.4 Test Procedure

1. The transmitter output was connected to the spectrum analyzer through an attenuator.
2. Set RBW of spectrum analyzer to 100KHz and VBW to 100KHz.
3. Set Detector to Peak, Trace to Max Hold and Sweep Time is Auto.
4. Observe frequency hopping in 2400MHz~2483.5MHz, there are at least 32 non-overlapping channels.
5. Repeat above 1~3 points for the middle and highest channel of the EUT.

### 7.5 Test Result

Temperature ( °C ) : 22~23	EUT: Bluetooth Speaker
Humidity (%RH) : 50~54	M/N: HS-809
Barometric Pressure ( mbar ) : 950~1000	Operation Condition: Tx Mode

Modulation Type	Frequency (MHz)	Number of Hopping Channels	Min. Limit
GFSK	2402~2480	79	≥ 15
Pi/4 DQPSK	2402~2480	79	≥ 15

# BDR-1M

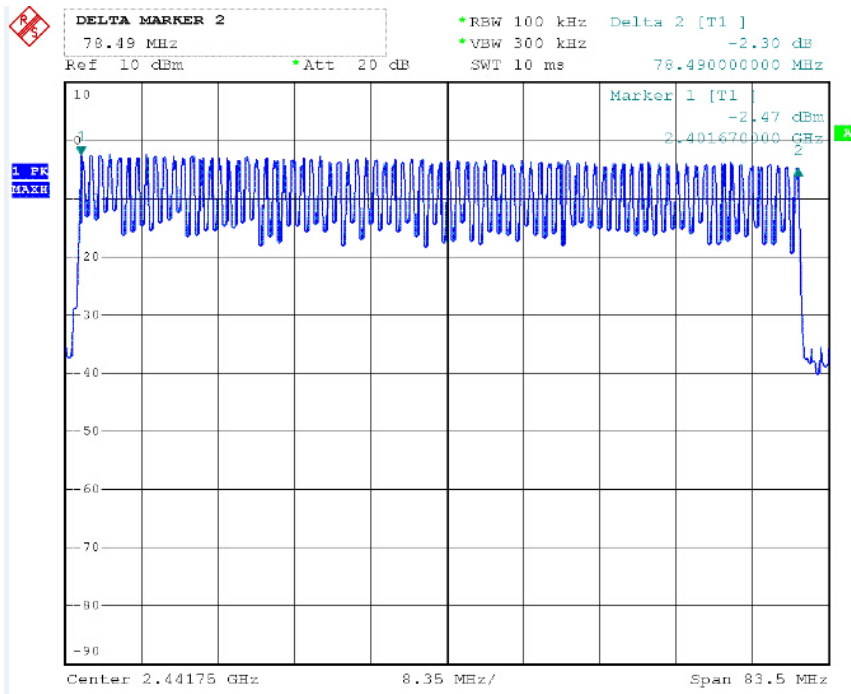

# EDR-2M

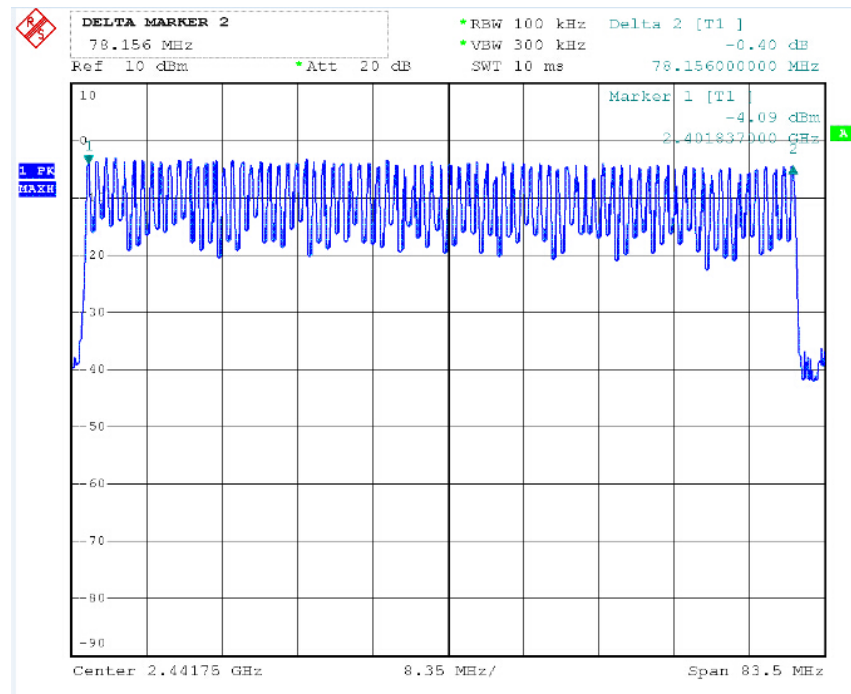

## 8. Test of Dwell Time of Each Frequency

### 8.1 Applicable standard

Section 15.247(a)(1)(iii): For frequency hopping systems operating in the 2400-2483.5 MHz band The average time of occupancy on any channel shall not be greater than 0.4 seconds within a period of 0.4seconds multiplied by the number of hopping channels employed.

### 8.2 EUT Setup

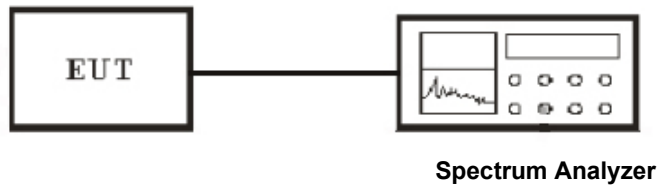

### 8.3 Test Equipment List and Details

See section 2.5.

### 8.4 Test Procedure

1. The transmitter output was connected to the spectrum analyzer through an attenuator.
2. Set RBW of spectrum analyzer to 1000kHz and VBW to 1000kHz.
3. Set Detector to Peak, Trace to Max Hold and Sweep Time is more than once pulse time.
4. Set the center frequency on any frequency would be measure and set the frequency span to zero span.
5. Measure the maximum time duration of one single pulse.

### 8.5 Test Result

Temperature ( °C ) : 22~23	EUT: Bluetooth Speaker
Humidity (%RH ) : 50~54	M/N: HS-809
Barometric Pressure ( mbar ) : 950~1000	Operation Condition: Tx Mode

Dwell time=  $t^*(1.6/6/79)*31.6$

**BDR 1M**

Modulation Type	Channel	Reading (ms)	Dwell Time (ms)	Limit (ms)
GFSK	Low	2.206	235.31	400
GFSK	Middle	2.206	235.31	400
GFSK	High	2.206	235.31	400

**EDR 2M**

Modulation Type	Channel	Reading (ms)	Dwell Time (ms)	Limit (ms)
Pi/4 DQPSK	Low	2.494	266.03	400
Pi/4 DQPSK	Middle	2.492	265.81	400
Pi/4 DQPSK	High	2.494	266.03	400



# BDR-DH5 Channel Low

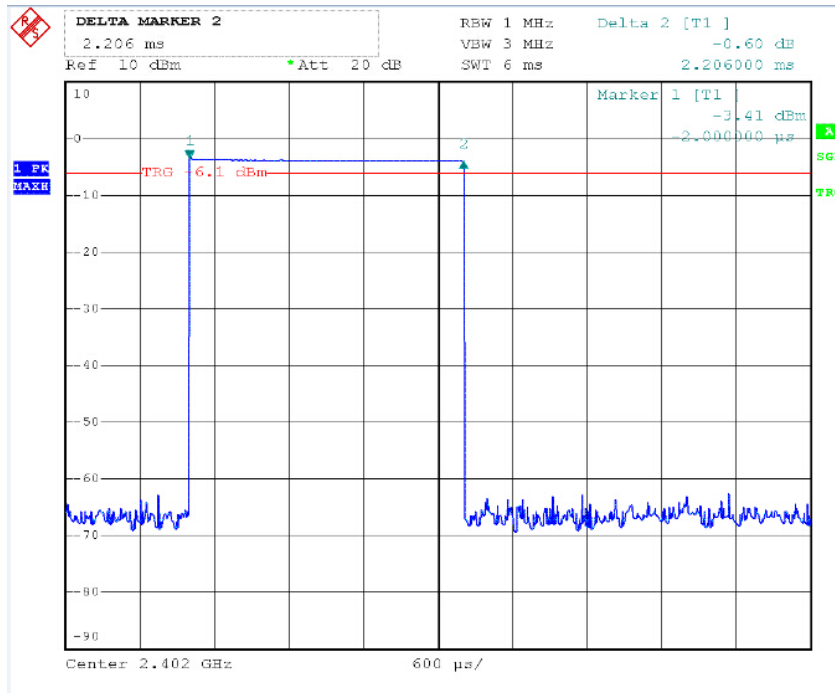

# Channel Middle

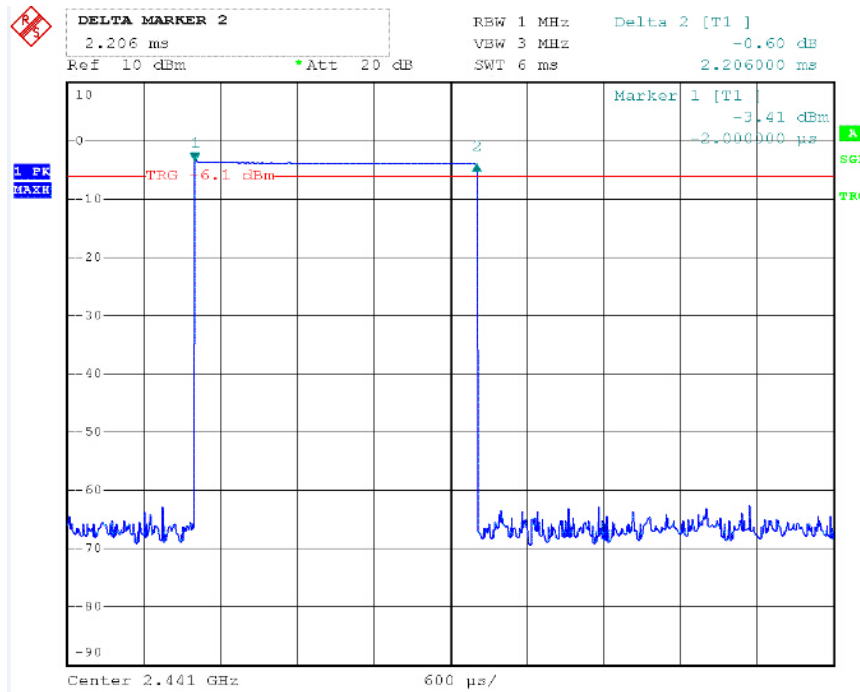

### Channel High

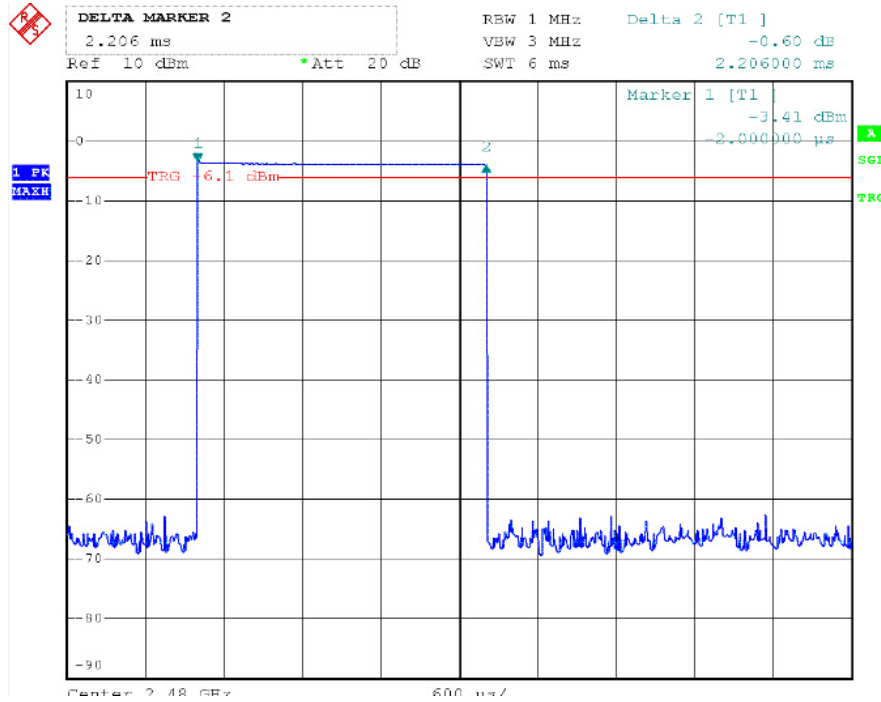

### EDR-DH5 Channel Low

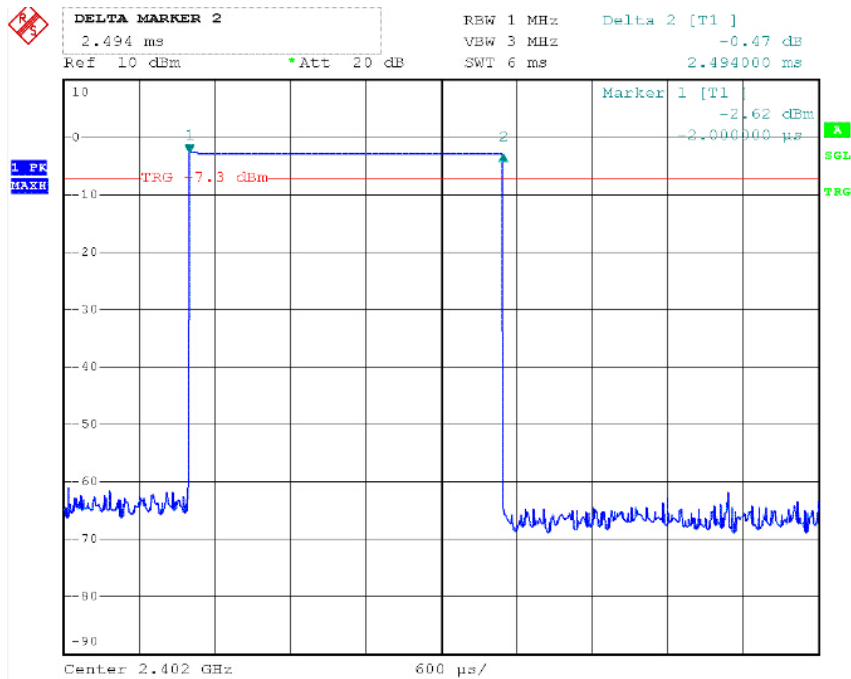

### Channel Middle

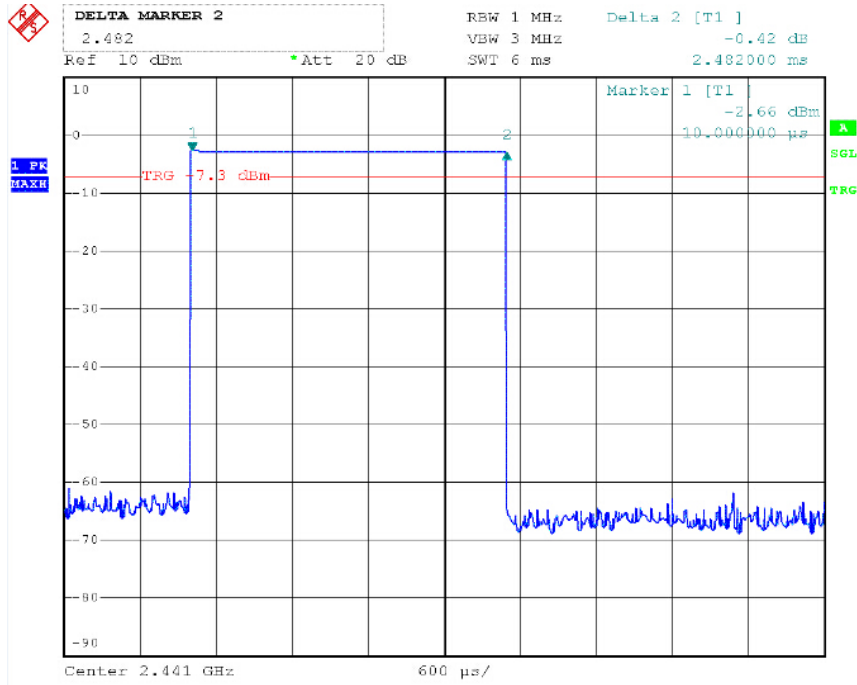

### Channel High

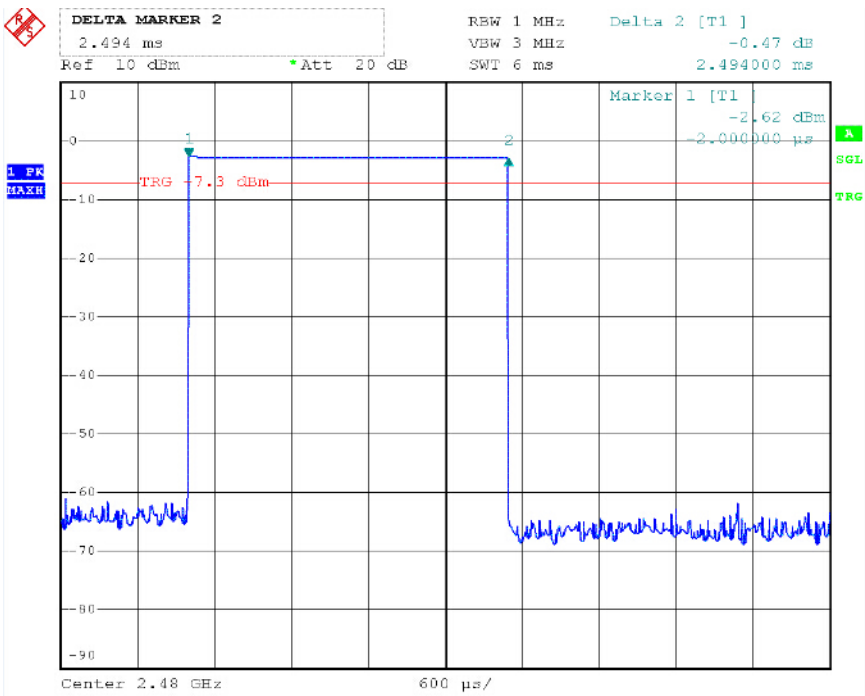

## 9. Test of Maximum Peak Output Power

### 9.1 Applicable standard

Section 15.247(b)(1): For frequency hopping systems operating in the 2400-2483.5 MHz band employing at least 75 non-overlapping hopping channels and The maximum peak output power shall not exceed 1 watt. For all other frequency hopping systems in this frequency band, The maximum peak output power shall not exceed 0.125 watt.

### 9.2 EUT Setup

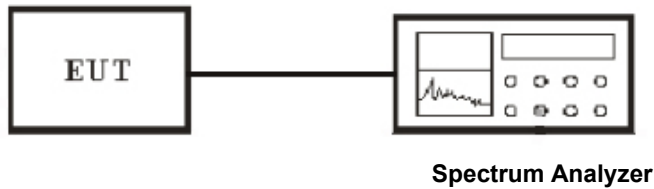

### 9.3 Test Equipment List and Details

See section 2.5.

### 9.4 Test Procedure

1. The transmitter output was connected to the peak power meter and recorded the peak value.
2. Peak power meter parameter set to auto attenuator and filter is the same as.
3. Repeated the 1 for the middle and highest channel of the EUT.

### 9.5 Test Result

Temperature ( °C ) : 22~23	EUT: Bluetooth Speaker
Humidity (%RH ) : 50~54	M/N: HS-809
Barometric Pressure ( mbar ) : 950~1000	Operation Condition: Tx Mode

**BDR 1M**

Modulation Type	Channel No.	Frequency (MHz)	Output Power (dBm)	Limits (dBm)	Margin (dB)
GFSK	Low	2402.00	-2.73	21	-23.73
GFSK	Middle	2441.00	-0.48	21	-21.48
GFSK	High	2480.00	-1.94	21	-22.94

**EDR 2M**

Modulation Type	Channel No.	Frequency (MHz)	Output Power (dBm)	Limits (dBm)	Margin (dB)
Pi/4 DQPSK	Low	2402.00	-1.19	21	-22.19
Pi/4 DQPSK	Middle	2441.00	-2.84	21	-23.84
Pi/4 DQPSK	High	2480.00	-4.85	21	-25.85

**BDR 1M  
Channel Low**

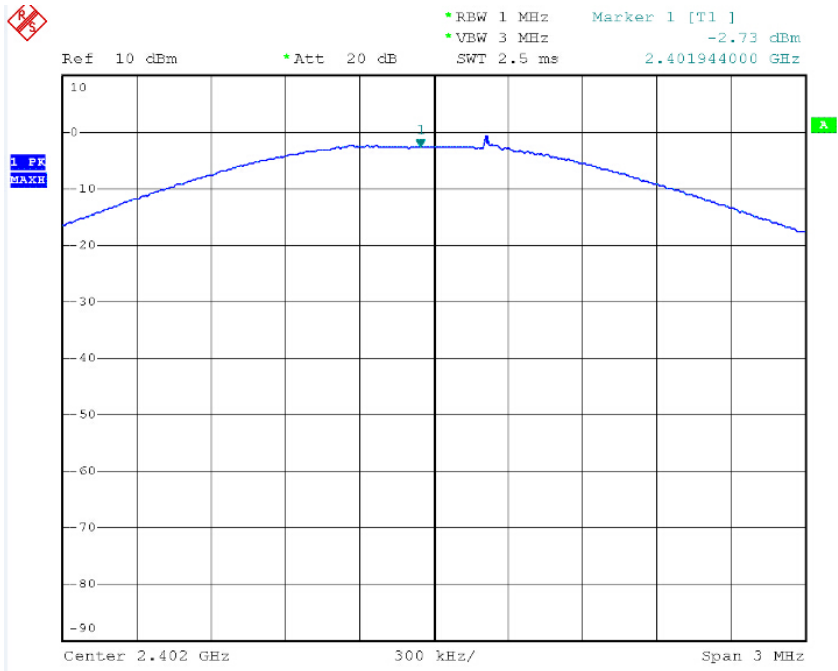

**Channel Middle**

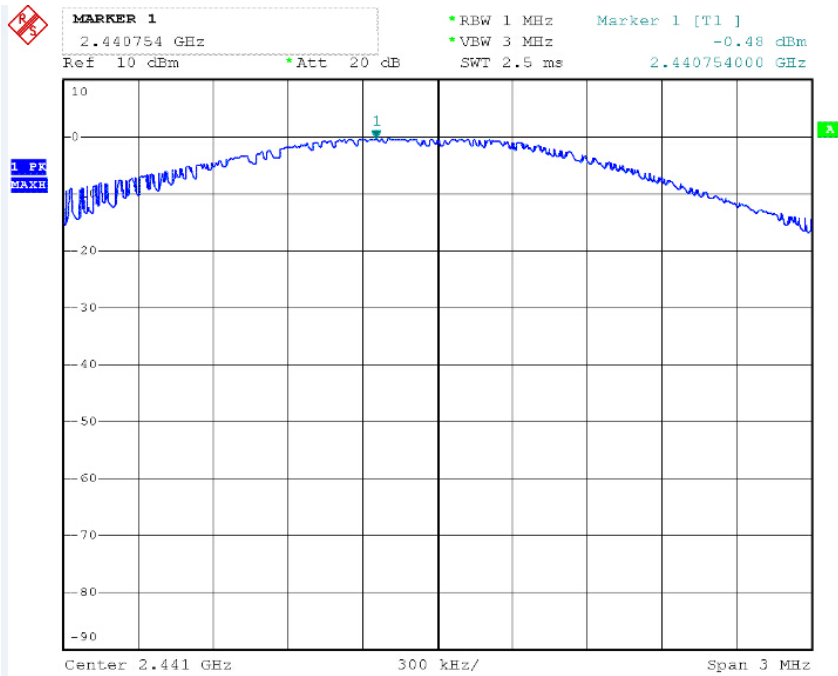

### Channel High

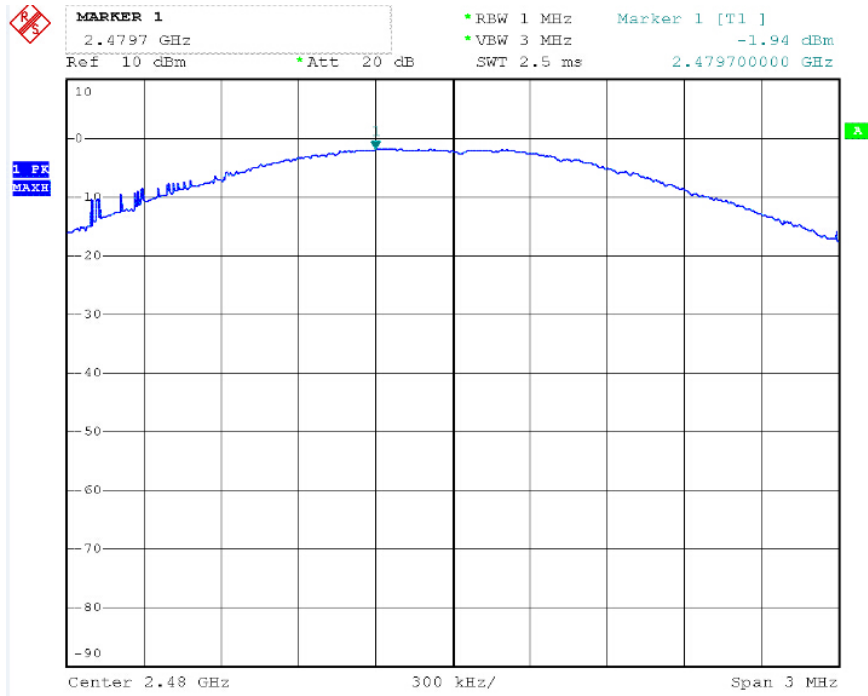

### EDR 2M Channel Low

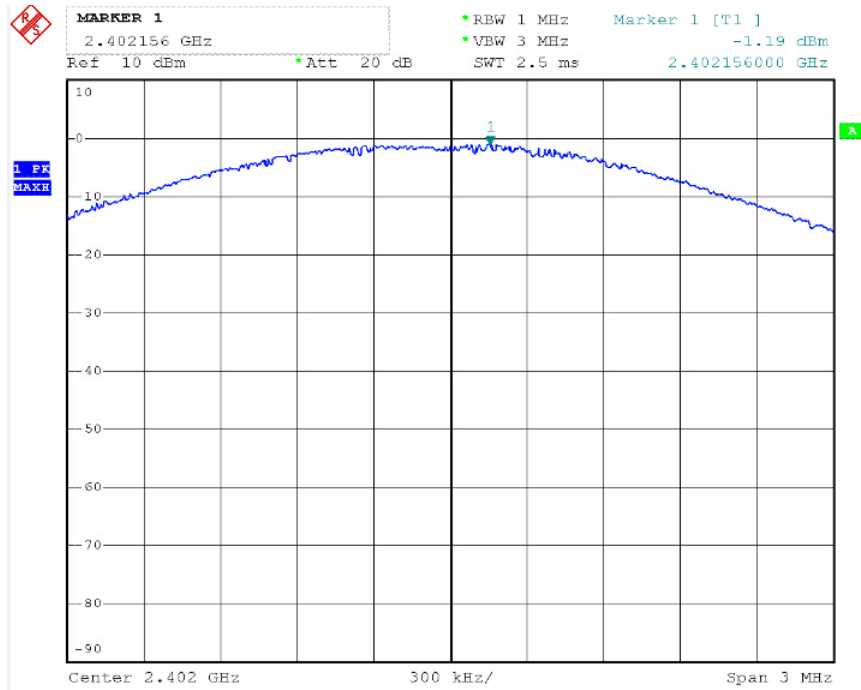

### Channel Middle

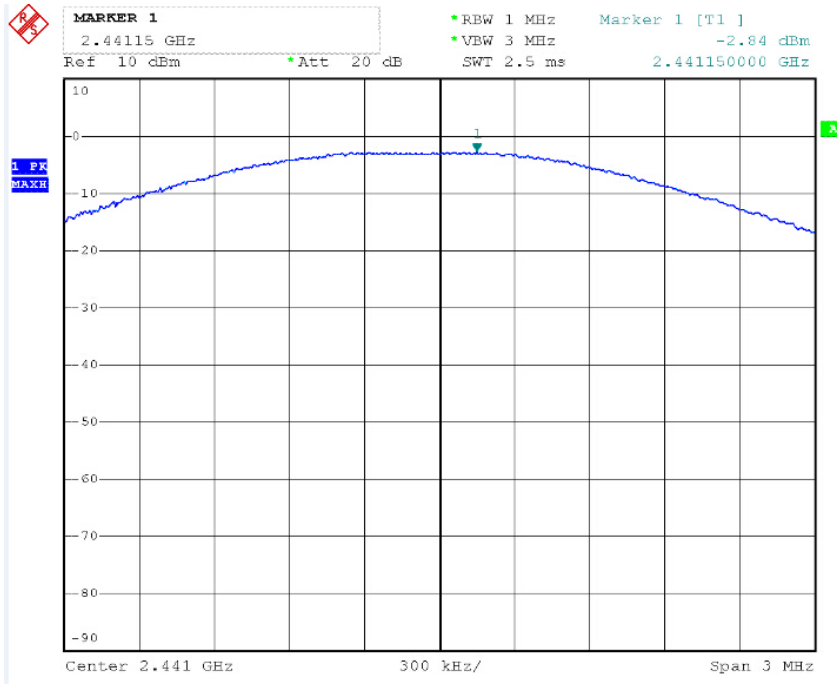

### Channel High

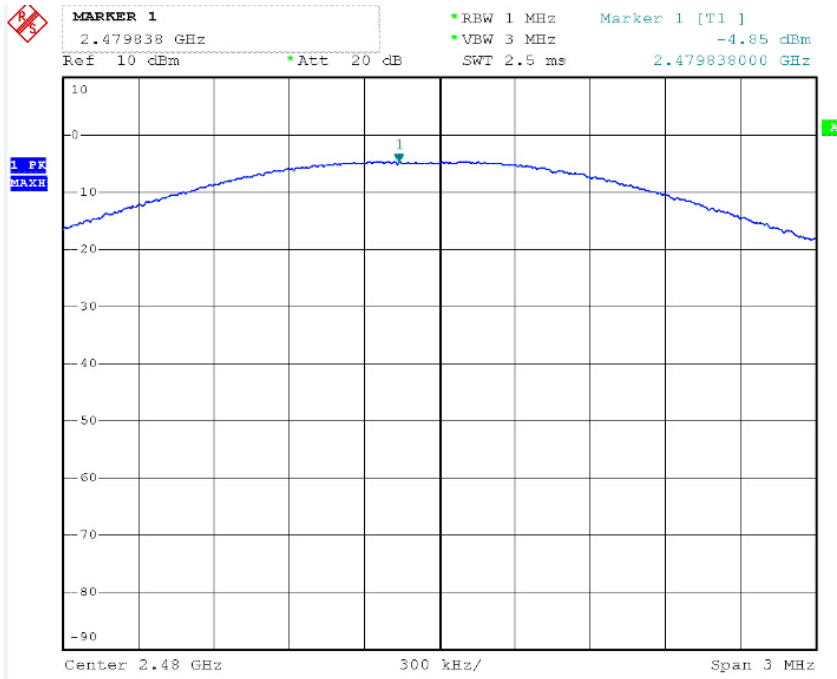



## 10. Test of Band Edges Emission

### 10.1 Applicable standard

Section 15.247(d): In any 100 kHz bandwidth outside the frequency band in which the spread spectrum or digitally modulated intentional radiator is operating, the radio frequency power that is produced by the intentional radiator shall be at least 20 dB below that in the 100 kHz bandwidth within the band that contains the highest level of the desired power, based on either an RF conducted or a radiated measurement. In addition, radiated emissions that fall in the restricted bands, as defined in Section 15.205, must also comply with the radiated emission limits specified in Section 15.209.

### 10.2 EUT Setup

Radiated Measurement Setup

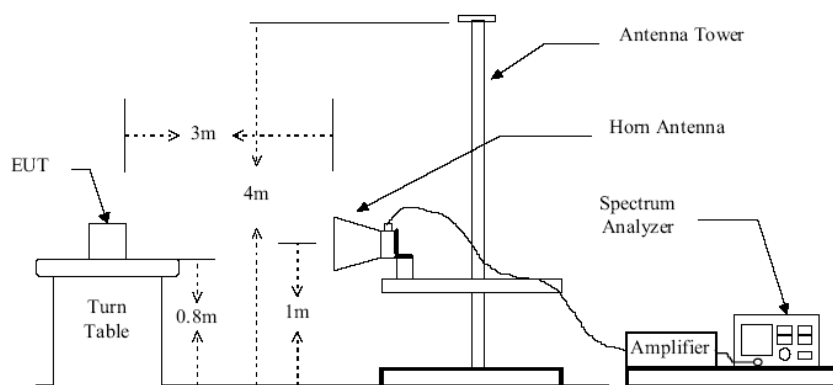
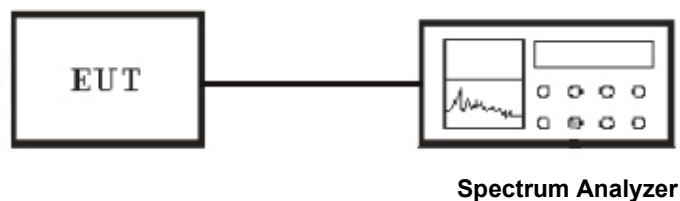

Figure 2 : Frequencies measured above 1 GHz configuration

Conducted Measurement Setup



### 10.3 Test Equipment List and Details

See section 2.5.

### 10.4 Test Procedure

Conducted Measurement

1. The transmitter is set to the lowest channel.
2. The transmitter output was connected to the spectrum analyzer via a cable .

3. Set both RBW and VBW of spectrum analyzer to 100KHz with convenient frequency span including 100MHz bandwidth from lower band edge. Then detector set to peak and max hold this trace.
4. The lowest band edges emission was measured and recorded.
5. The transmitter set to the highest channel and repeated 2~4.

**Radiated Measurement**

1. Configure the EUT according to ANSI C63.4-2003
2. The turntable was rotated by 360 degrees to determine the position of the highest radiation.
3. The height of the broadband receiving antenna was varied between one meter and four meters above ground to find the maximum emission field strength of both horizontal and vertical polarization.
4. For band edge emission, the antenna tower was scan (from 1 M to 4 M) and then the turn table was rotated (from 0 degree to 360 degrees) to find the maximum reading.
5. For band edge emission, use 1MHz VBW and 1MHz RBW for reading under AV and use 1MHz VBW and 1MHz RBW for reading under PK.

**10.5 Test Result**

Temperature ( °C ) : 22~23	EUT: Bluetooth Speaker
Humidity (%RH ) : 50~54	M/N: HS-809
Barometric Pressure ( mbar ) : 950~1000	Operation Condition: Tx Mode

**Radiated Test Result**

**Worst Case BDR 1M**

Frequency (MHz)	Antenna Polarization	Emission Read Value (dBµV/m)	Limits (dBµV/m)
2389.5	H	34.55	54
2389.5	V	35.34	54
2483.7	H	36.61	54
2483.7	V	37.76	54

**Worst Case EDR 2M**

Frequency (MHz)	Antenna Polarization	Emission Read Value (dBµV/m)	Limits (dBµV/m)
2389.4	H	34.67	54
2389.4	V	35.90	54
2483.7	H	36.32	54
2483.7	V	35.64	54

**Conducted Test Result  
BDR 1M  
Low Channel**

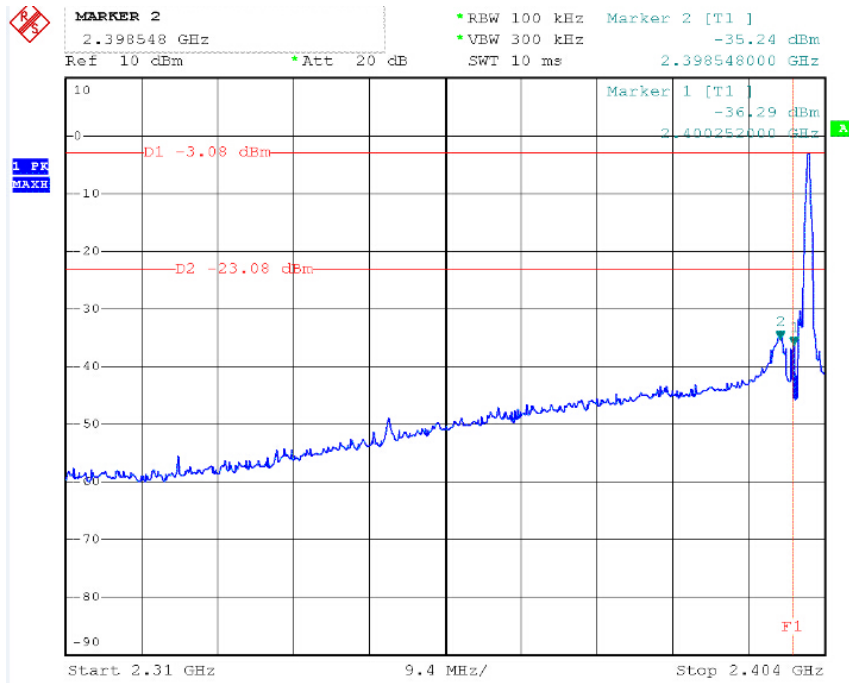

**High Channel**

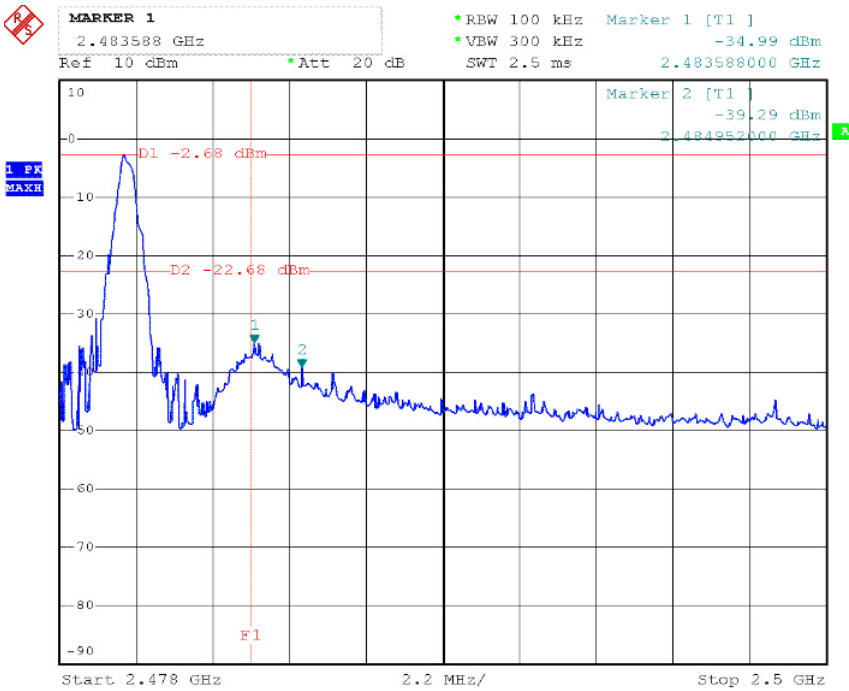

**EDR 2M  
Low Channel**

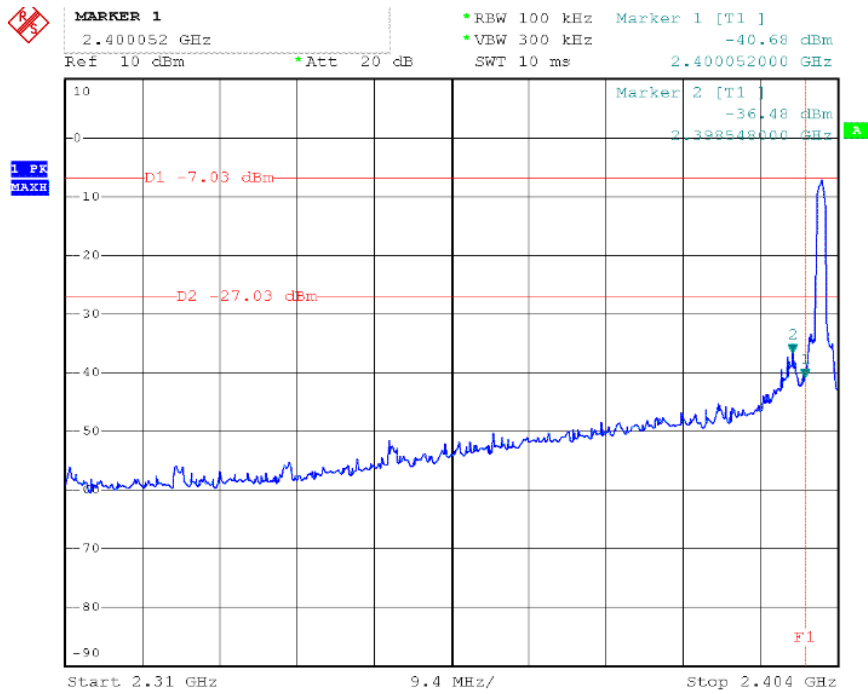

**High Channel**

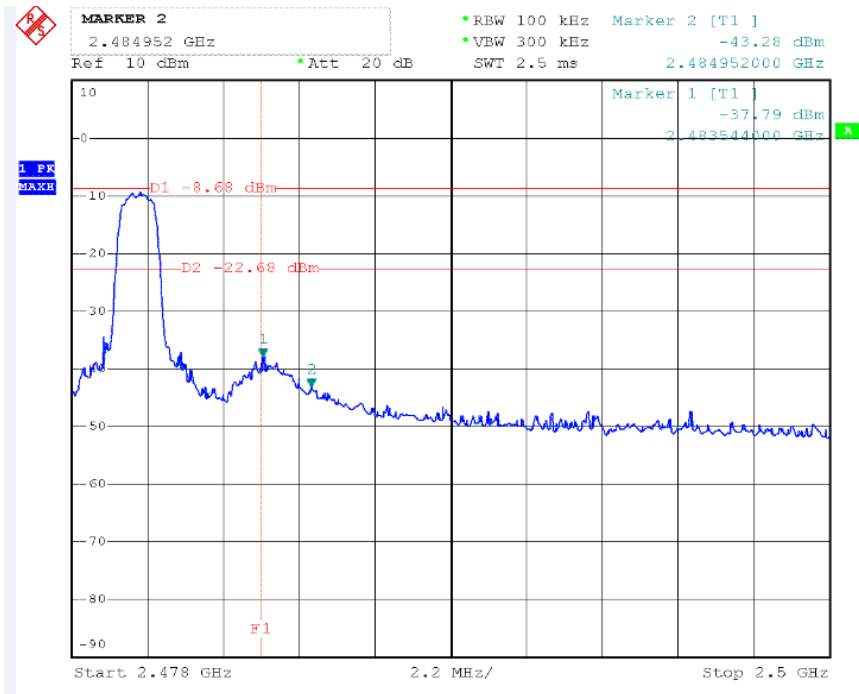

# Hopping Mode Worst case BDR 1M Low

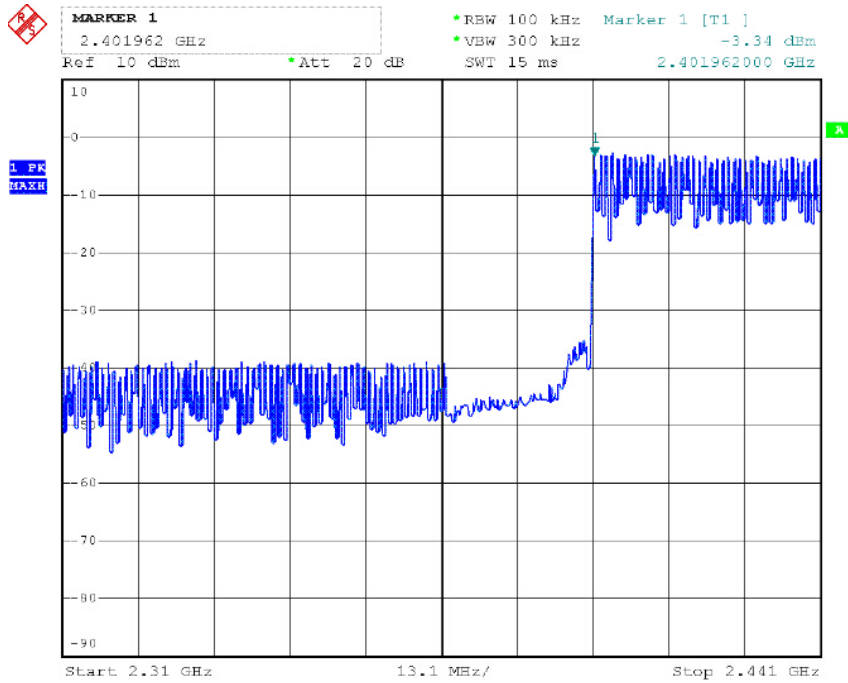

# High

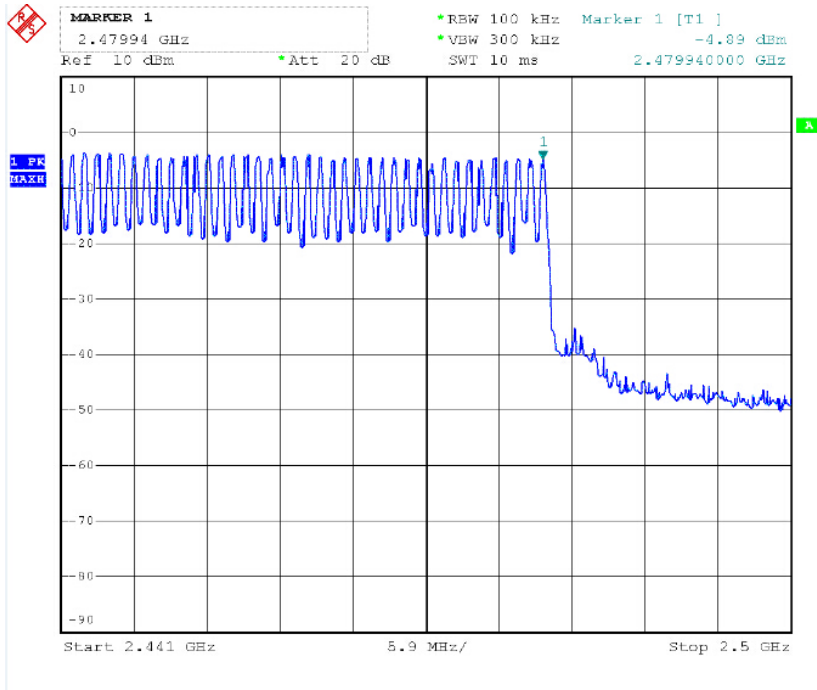

# 11. Test of Spurious Radiated Emission

## 11.1 Applicable standard

Section 15.247(d): In any 100 kHz bandwidth outside the frequency band in which the spread spectrum or digitally modulated intentional radiator is operating, the radio frequency power that is produced by the intentional radiator shall be at least 20 dB below that in the 100 kHz bandwidth within the band that contains the highest level of the desired power, based on either an RF conducted or a radiated measurement. In addition, radiated emissions that fall in the restricted bands, as defined in Section 15.205, must also comply with the radiated emission limits specified in Section 15.209.

## 11.2 EUT Setup

### Conducted Measurement Setup

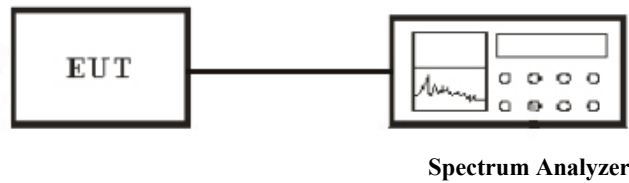

### Radiated Measurement Setup

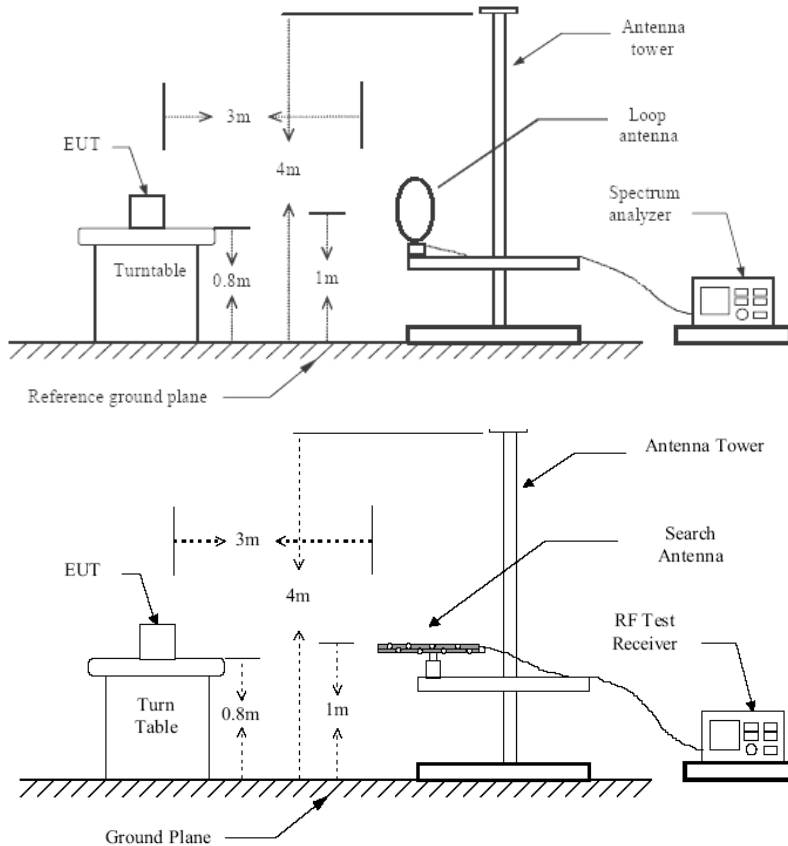

Figure 1 : Frequencies measured below 1 GHz configuration

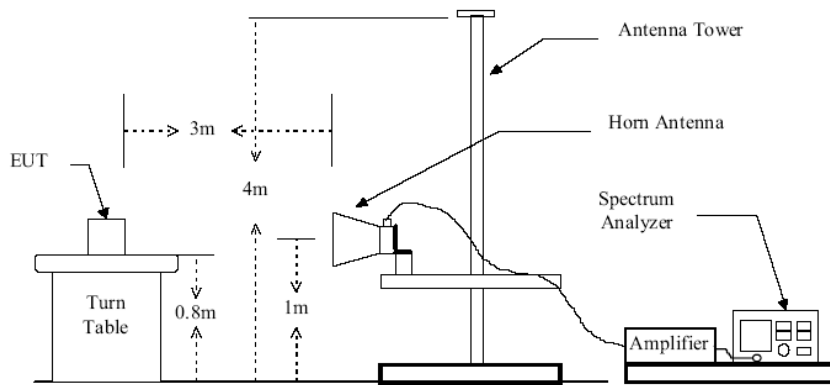

Figure 2 : Frequencies measured above 1 GHz configuration

### 11.3 Test Equipment List and Details

See section 2.5.

### 11.4 Test Procedure

#### Conducted Measurement

1. For emission above 1GHz to 26G,conducted measurement method is used.
2. The transmitter is set to the lowest channel.
3. The transmitter output was connected to the spectrum analyzer via a cable and cable loss is used as the offset of the spectrum analyzer.
4. Set RBW to 1 MHz and VBW to 3 MHz, Then detector set to peak and max hold this trace.
5. The lowest band edges emission was measured and recorded.
6. The transmitter set to the highest channel and repeated 2~4.

#### Radiated Measurement

1. Configure the EUT according to ANSI C63.4-2003
2. The EUT was placed on the top of the turntable 0.8 meter above ground.
3. Receiving antenna mounted on the top of a height-variable antenna tower was placed 3 meters far away from the turntable. When the frequency spectrum measured started from 9 kHz to 30 MHz, a loop antenna is used. When the frequency spectrum measured started from 30 MHz to 1000 MHz and above 1000 MHz, a broadband receiving antenna and the horn antenna are used.
4. Power on the EUT and all the supporting units.
5. The turntable was rotated by 360 degrees to determine the position of the highest radiation.
6. The height of the broadband receiving antenna was varied between one meter and four meters above ground to find the maximum emission field strength of both horizontal and vertical polarization.
7. For each suspected emission, the antenna tower was scanned (from 1 M to 4 M) and then the turntable was rotated (from 0 degree to 360 degrees) to find the maximum reading.

8. According to the characteristic of the EUT crystals, the range of frequencies was investigated from 9KHz to 30MHz, 30MHz to 1GHz and 1GHz to 26GHz.

9. For emission below 1GHz, Set the test-receiver system to Peak or CISPR quasi-peak Detect Function with specified bandwidth under Maximum Hold Mode.

10. For emission above 1GHz, Set the RBW=1MHz,VBW=3MHz for Peak Detector while the RBW=1MHz, VBW=10Hz for Average Detector, Readings are both peak and average values.

11. The pre-test have done for the EUT in three axes and found the worst emission at position shown in test setup photos. The worst case data is recorded in the report. All emission not reported are much lower than the prescribed limits.

### 11.5 Test Result

Temperature ( °C ) : 22~23	EUT: Bluetooth Speaker
Humidity (%RH ) : 50~54	M/N: HS-809
Barometric Pressure ( mbar ) : 950~1000	Operation Condition: TX Mode