

## Test report

**Report No.:** HP190708DC001-FRL  
**FCC ID:** 2ACYT-MT7668U  
**Product Name** wireless module  
**Test Model:** MT7668U  
**Received Date:** 2019-7-11  
**Test Date:** 2019-7-12~2019-7-25  
**Issued Date:** 2019-8-26  
**Applicant Name:** SHENZHEN Hitevision Technology Co., Ltd.  
**Applicant Address:** No. 8, Qinglan 1st Road, Pingshan Shenzhen China  
**Issued By:** Hwa-Hsing (Dongguan) Testing Co., Ltd.  
**Lab Address:** No.101, Bld N1,Yuyuan 2Rd, Yuyuan Industrial Park, HuangJiang Town, Dongguan, China  
**Test Location:** No.101, Bld N1,Yuyuan 2Rd, Yuyuan Industrial Park, HuangJiang Town, Dongguan, China  
**FCC Designation Number:** CN1255  
**Standards:** FCC Part 15, Subpart E, Section 15.407

The above equipment has been tested by [HWA-HSING](#), and found compliance with the requirement of the above standards. The test record, data evaluation & Equipment Under Test (EUT) configurations represented herein are true and accurate accounts of the measurements of the sample's EMC characteristics under the conditions specified in this report.

**Prepared by :** Tank , **Date:** Aug. 26 2019  
Tank Tan//Engineer

**Approved by :** Harry Li , **Date:** Aug. 26 2019  
Harry Li/ Supervisor

For Lab's declaration: This report is for your exclusive use. Any copying or replication of this report to or for any other person or entity, or use of our name or trademark, is permitted only with our prior written permission. This report sets forth our findings solely with respect to the test samples identified herein. The results set forth in this report are not indicative or representative of the quality or characteristics of the lot from which a test sample was taken or any similar or identical product unless specifically and expressly noted. Our report includes all of the tests requested by you and the results thereof based upon the information that you provided to us. You have 60 days from date of issuance of this report to notify us of any material error or omission caused by our negligence, provided, however, that such notice shall be in writing and shall specifically address the issue you wish to raise. A failure to raise such issue within the prescribed time shall constitute your unqualified acceptance of the completeness of this report, the tests conducted and the correctness of the report contents. Unless specific mention, The uncertainty of measurement has been explicitly taken into account to declare the compliance or non-compliance to the specification.

**Table of contents**

<b>Release Control Record</b> .....	<b>4</b>
<b>1. Summary Of Test Results</b> .....	<b>5</b>
1.1 Measurement Uncertainty .....	5
<b>2. General Information</b> .....	<b>6</b>
2.1 General Description Of EUT.....	6
2.2 Description Of Test Modes.....	7
2.2.1 Test Mode Applicability And Tested Channel Detail .....	9
2.3 Duty Cycle Of Test Signal .....	13
2.4 Description Of Support Units.....	15
2.5 General Description Of Applied Standards .....	15
<b>3. Test Types And Results</b> .....	<b>16</b>
3.1 Radiated Emission And Band-Edge Measurement.....	16
3.1.1 Limits Of Radiated Emission And Band-Edge Measurement .....	16
3.1.2 Limits Of Unwanted Emission Out Of The Restricted Bands.....	16
3.1.3 Test Instruments .....	17
3.1.4 Test Procedures.....	18
3.1.5 Deviation From Test Standard.....	18
3.1.6 Test Setup.....	19
3.1.7 Test Results .....	21
3.2 Conducted Emission Measurement .....	61
3.2.1 Limits Of Conducted Emission Measurement.....	61
3.2.2 Test Instruments .....	61
3.2.3 Test Procedures.....	62
3.2.4 Deviation From Test Standard.....	62
3.2.5 Test Setup.....	62
3.2.6 EUT Operating Conditions .....	62
3.2.7 Test Results .....	63
3.3 Transmit Power Measurement .....	65
3.3.1 Limits Of Transmit Power Measurement.....	65
3.3.2 Test Setup.....	65
3.3.3 Test Instruments .....	66
3.3.4 Test Procedure .....	66

3.3.5	Deviation From Test Standard .....	67
3.3.6	EUT Operating Conditions .....	67
3.3.7	Test Results .....	68
3.4	Peak Power Spectral Density Measurement.....	78
3.4.1	Limits Of Peak Power Spectral Density Measurement .....	78
3.4.2	Test Setup.....	78
3.4.3	Test Instruments .....	78
3.4.4	Test Procedures.....	78
3.4.5	Deviation From Test Standard .....	79
3.4.6	EUT Operating Conditions .....	79
3.4.7	Test Results .....	80
3.5	Frequency Stability.....	87
3.5.1	Limits Of Frequency Stability Measurement .....	88
3.5.2	Test Setup.....	88
3.5.3	Test Instruments .....	88
3.5.4	Test Procedure .....	89
3.5.5	Deviation From Test Standard .....	89
3.5.6	EUT Operating Condition.....	89
3.5.7	Test Results .....	90
<b>4.</b>	<b>Photographs Of The Test Configuration .....</b>	<b>93</b>
<b>5.</b>	<b>Appendix A – Modifications Recorders For Engineering Changes .....</b>	<b>94</b>
<b>6.</b>	<b>Appendix B – Information On The Testing Laboratories .....</b>	<b>95</b>

**Release control record**

<b>Issue no.</b>	<b>Reason for change</b>	<b>Date issued</b>
HP190708DC001-FRL	Original release.	Aug. 26 2019

### 1. Summary of test results

The EUT has been tested according to the following specifications:

FCC part 15, subpart e (section 15.407 under new rule)			
ANSI C63.10:2013			
Standard section	Test type	Result	Remark
15.407(b)(6)	AC Power Conducted Emissions	PASS	Meet the requirement of limit.
15.407(b) (1/2/3/4/6)	Radiated Emissions & Band Edge Measurement	PASS	Meet the requirement of limit.
15.407(b) (1/2/3)	Emission bandwidth	PASS	Meet the requirement of limit.
15.407(a)(1/2/3)	Max Average Transmit Power	PASS	Meet the requirement of limit.
15.407(a)(1/2/3)	Peak Power Spectral Density	PASS	Meet the requirement of limit.
15.407(g)	Frequency Stability	PASS	Meet the requirement of limit.
15.203	Antenna Requirement	PASS	No antenna connector is used

#### 1.1 Measurement uncertainty

Where relevant, the following measurement uncertainty levels have been estimated for tests performed on the EUT as specified in CISPR 16-4-2:

Measurement	Frequency	Uncertainty
Conducted emissions	150kHz ~ 30MHz	2.66 dB
Radiated emissions	9KHz ~ 30MHz	2.90dB
	30MHz ~ 1000MHz	3.47 dB
	1GHz ~ 18GHz	4.84 dB
	18GHz ~ 40GHz	4.62 dB

This uncertainty represents an expanded uncertainty expressed at approximately the 95% confidence level using a coverage factor of k = 2.

## 2. General information

### 2.1 General description of EUT

Product name	wireless module
Brand Name	N/A
Model name.	MT7668U
Series Model	N/A
FCC ID number	2ACYT-MT7668U
Power supply	DC5V from USB
Status of EUT	Engineeringprototype
Modulation technology	OFDM
Modulation type	256QAM, 64QAM, 16QAM, QPSK, BPSK
Transfer rate	802.11a: 54.0/ 48.0/ 36.0/ 24.0/ 18.0/ 12.0/ 9.0/ 6.0Mbps 802.11n: up to 300.0Mbps 802.11ac : up to 867Mbps
Operating frequency	5180~5240MHz, 5260~5320MHz 5500~5700MHz, 5745~5825MHz
Number of channel	See the section 2.2
Conducted output power	15.71dBm for 5150 ~ 5250MHz (Maximum AVG Power) 16.72dBm for 5250 ~ 5350MHz (Maximum AVG Power) 17.44dBm for 5470 ~ 5725MHz (Maximum AVG Power) 20.95dBm for 5725 ~ 5850MHz (Maximum AVG Power)
Antenna type& Antenna Gain	5180 ~ 5240MHz: Dipole antenna with 3.98dBi gain 5260 ~ 5320MHz: Dipole antenna with 3.81dBi gain 5500 ~ 5700MHz: Dipole antenna with 3.50dBi gain 5745 ~ 5825MHz: Dipole antenna with 2.56dBi gain
Antenna connector	SMA
Accessory Device	N/A
Software/Firmware Version	FWv.63770
Cable supplied	N/A.
EUT Category	Mobile and Portable client device

**Note:**

1. For a more detailed features description, please refer to the manufacturer's specifications or the user's manual.
2. For the test results, the EUT had been tested with all conditions. But only the worst case was shown in test report.
3. Please refer to the EUT photo document for detailed product photo.

4. The EUT incorporates a MIMO function. Physically, the EUT provides 2 completed transmitter and 2 receiver.

Support mode	Transmit and receive mode	Transmit and Receive Chain
802.11a	MIMO	2TX,2RX
802.11n HT20	MIMO	2TX,2RX
802.11n HT40	MIMO	2TX,2RX
802.11ac VHT20	MIMO	2TX,2RX
802.11ac VHT40	MIMO	2TX,2RX
802.11ac VHT80	MIMO	2TX,2RX

\*The modulation and bandwidth are similar for 802.11n for 20MHz / 40MHz and 802.11ac mode for 20MHz/ 40MHz, therefore investigated worst case to representative mode in test report.

## 2.2 Description of test modes

### For 5150 ~ 5250MHz

4 channels are provided for 802.11a, 802.11a c 20MHz, 802.11n (20MHz):

Channel	Frequency	Channel	Frequency
36	5180 MHz	40	5200 MHz
44	5220 MHz	48	5240 MHz

2 channels are provided for 802.11a c 40MHz, 802.11n (40MHz):

Channel	Frequency	Channel	Frequency
38	5190 MHz	46	5230 MHz

1 channel is provided for 802.11ac (80MHz):

Channel	Frequency	Channel	Frequency
42	5210MHz	--	--

### For 5250 ~ 5350MHz

4 channels are provided for 802.11a, 802.11a c 20MHz, 802.11n (20MHz):

Channel	Frequency	Channel	Frequency
52	5260 MHz	56	5280 MHz
60	5300 MHz	64	5320 MHz

2 channels are provided for 802.11a c 40MHz, 802.11n (40MHz):

Channel	Frequency	Channel	Frequency
54	5270 MHz	62	5310 MHz

1 channel is provided for 802.11ac (80MHz):

Channel	Frequency	Channel	Frequency
58	5290MHz	--	--

**For 5470 ~ 5725MHz**

11 channels are provided for 802.11a, 802.11a c 20MHz, 802.11n (20MHz):

Channel	Frequency	Channel	Frequency
100	5500 MHz	104	5520 MHz
108	5540 MHz	112	5560 MHz
116	5580 MHz	120	5600 MHz
124	5620 MHz	128	5640 MHz
132	5660 MHz	136	5680 MHz
140	5700 MHz	--	--

4 channels are provided for 802.11a c 40MHz, 802.11n (40MHz):

Channel	Frequency	Channel	Frequency
102	5510 MHz	110	5550 MHz
118	5590 MHz	134	5670 MHz

2 channel is provided for 802.11ac (80MHz):

Channel	Frequency	Channel	Frequency
106	5530MHz	122	5610MHz

**For 5725 ~ 5850MHz**

5 channels are provided for 802.11a, 802.11a c 20MHz, 802.11n (20MHz):

Channel	Frequency	Channel	Frequency
149	5745MHz	153	5765MHz
157	5785MHz	161	5805MHz
165	5825MHz	--	--

2 channels are provided for 802.11a c 40MHz, 802.11n (40MHz):

Channel	Frequency	Channel	Frequency
151	5755MHz	159	5795MHz

1 channel is provided for 802.11ac (80MHz):

Channel	Frequency	Channel	Frequency
155	5775MHz	--	--



**2.2.1 Test mode applicability and tested channel detail**

EUT Configure mode	Applicable test items				Description
	RE≥1G	RE≤1G	PLC	APCM	
802.11a	√	√	√	√	<b>Fully test</b>
802.11n HT20	√	√	√	√	<b>Fully test</b>
802.11n HT40	√	√	√	√	<b>Fully test</b>
802.11ac VHT20	√	√	√	√	Power check
802.11ac VHT40	√	√	√	√	Power check
802.11ac VHT80	√	√	√	√	<b>Fully test</b>

**Where:**  
**RE≥1G:** Radiated Emission above 1GHz  
**RE≤1G:** Radiated Emission below 1GHz  
**PLC:** Power Line Conducted Emission  
**APCM:** Antenna Port Conducted Measurement

**Radiated Emission:** The EUT had been pre-tested on the positioned of each 3 axis.

Pretest mode:802.11a, Channel 38 transmitting.

The worst case was found when positioned on **Z-plane**.

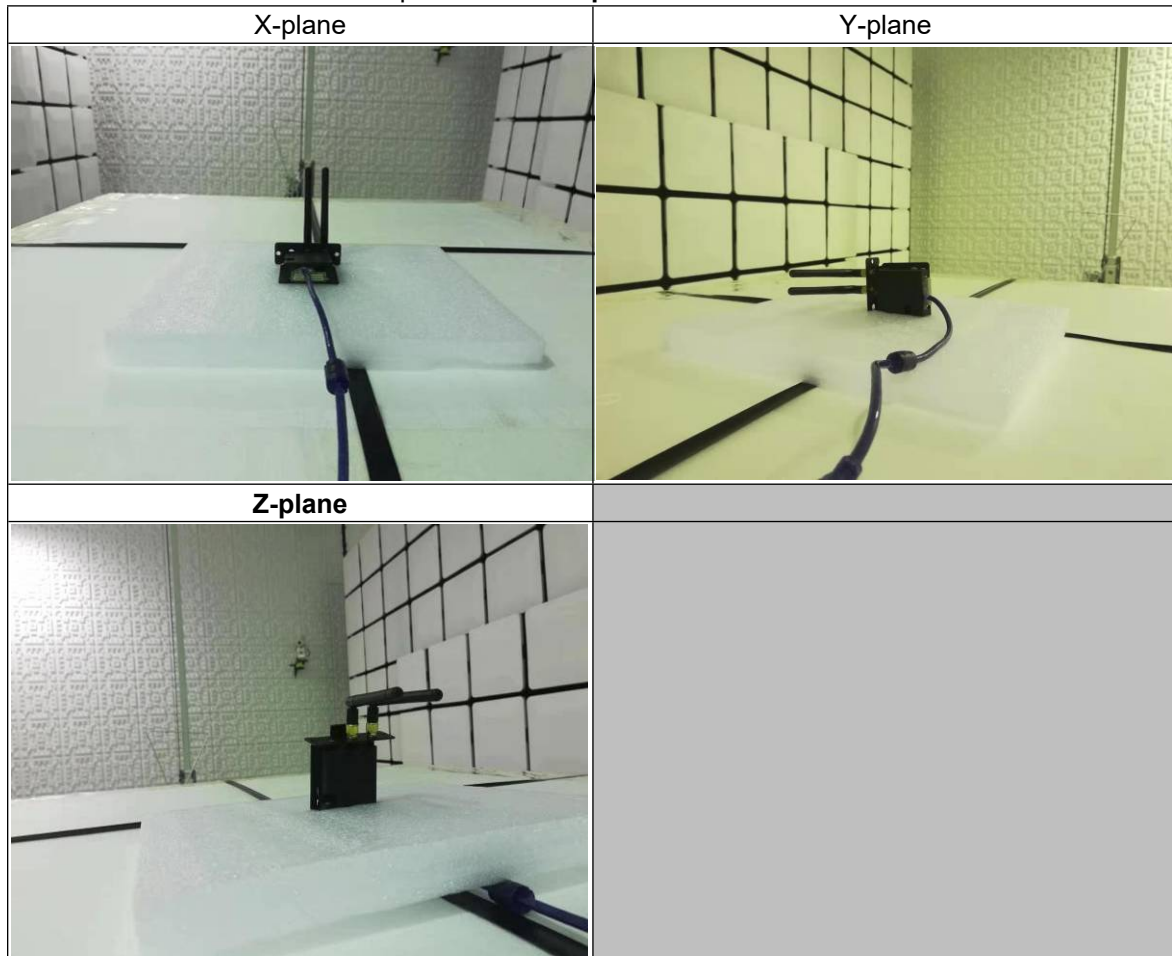

**Antenna Transmitter technique:**

EUT Configure mode	SISO	SISO	MIMO	Description
	Ant 0	Ant 0	Ant 0+Ant 1	
<b>802.11a, CH36</b>	√	√	<b>Worst case mode</b>	<b>Max. field strength check</b> To determine the worst-case Transmitter mode
<b>802.11n (20MHz)</b>	√	√		
<b>802.11n (20MHz)</b>	-	-	√	<b>Max. conducted power check</b> To determine the worst-case mode
802.11ac (20MHz)	-	-	√	
<b>802.11n (40MHz)</b>	-	-	√	
802.11ac (40MHz)	-	-	√	

**Radiated emission test (above 1GHz):**

Pre-Scan has been conducted to determine the worst-case mode from all possible combinations between available modulations, data rates and antenna ports (if EUT with antenna diversity architecture).

Following channel(s) was (were) selected for the final test as listed below.

EUT configure mode	Worst position	Freq. Band (MHz)	Antenna Transmitter technique	Tested channel	Modulation technology	Modulation type	Data rate (Mbps)
802.11a	Z-plane	5150-5250	MIMO	36, 40, 48	OFDM	BPSK	6.0
802.11n (20MHz)	Z-plane		MIMO	36, 40, 48	OFDM	BPSK	6.5
802.11n (40MHz)	Z-plane		MIMO	38, 46	OFDM	BPSK	13.5
802.11ac 80MHz	Z-plane		MIMO	42	OFDM	BPSK	V0
802.11a	Z-plane	5250-5350	MIMO	52, 60, 64	OFDM	BPSK	6.0
802.11n (20MHz)	Z-plane		MIMO	52, 60, 64	OFDM	BPSK	MCS0
802.11n (40MHz)	Z-plane		MIMO	54, 62	OFDM	BPSK	MCS0
802.11ac 80MHz	Z-plane		MIMO	58	OFDM	BPSK	V0
802.11a	Z-plane	5470-5725	MIMO	100, 112, 140	OFDM	BPSK	6.0
802.11n (20MHz)	Z-plane		MIMO	100, 112, 140	OFDM	BPSK	MCS0
802.11n (40MHz)	Z-plane		MIMO	102, 110, 134	OFDM	BPSK	MCS0
802.11ac 80MHz	Z-plane		MIMO	106	OFDM	BPSK	V0
802.11a	Z-plane	5725-5850	MIMO	149, 157, 165	OFDM	BPSK	6.0
802.11n (20MHz)	Z-plane		MIMO	149, 157, 165	OFDM	BPSK	MCS0
802.11n (40MHz)	Z-plane		MIMO	151, 159	OFDM	BPSK	MCS0
802.11ac 80MHz	Z-plane		MIMO	155	OFDM	BPSK	V0

**Radiated emission test (below 1GHz):**
 Following channel(s) was (were) selected for the final test as listed below.

EUT Configure mode	Worst Position	Freq. Band (MHz)	Antenna Transmitter technique	Worst case channel	Modulation technology	Modulation type	Data rate (Mbps)
802.11a	Z-plane	5150-5250 5470-5725 5725-5850	MIMO	<b>159</b>	OFDM	BPSK	6.0

**Power line conducted emission test:**
 Pre-Scan has been conducted to determine the worst-case mode from all possible combinations between available modulations, data rates and antenna ports (if EUT with antenna diversity architecture).

 Following channel(s) was (were) selected for the final test as listed below.

EUT Configure mode	Worst Position	Freq. Band (MHz)	Antenna Transmitter technique	Tested channel	Modulation technology	Modulation type	Data rate (Mbps)
802.11a	-	5150-5250 5470-5725 5725-5850	MIMO	<b>159</b>	OFDM	BPSK	6.0

**Antenna port conducted measurement:**

- This item includes all test value of each mode, but only includes spectrum plot of worst value of each mode.
- Pre-Scan has been conducted to determine the worst-case mode from all possible combinations between available modulations, data rates and antenna ports (if EUT with antenna diversity architecture).
- Following channel(s) was (were) selected for the final test as listed below.

EUT configure mode	Antenna Transmitter technique	Freq. Band (MHz)	Tested channel	Modulation technology	Modulation type	Data rate (Mbps)
802.11a	MIMO	5150-5250	36, 40, 48	OFDM	BPSK	6.0
802.11n (20MHz)	MIMO		36, 40, 48	OFDM	BPSK	6.5
802.11n (40MHz)	MIMO		38, 46	OFDM	BPSK	13.5
802.11ac 80MHz	MIMO		42	OFDM	BPSK	V0
802.11a	MIMO	5250-5350	52, 60, 64	OFDM	BPSK	6.0
802.11n (20MHz)	MIMO		52, 60, 64	OFDM	BPSK	MCS0
802.11n (40MHz)	MIMO		54, 62	OFDM	BPSK	MCS0
802.11ac 80MHz	MIMO		58	OFDM	BPSK	V0
802.11a	MIMO	5470-5725	100, 112, 140	OFDM	BPSK	6.0
802.11n (20MHz)	MIMO		100, 112, 140	OFDM	BPSK	MCS0
802.11n (40MHz)	MIMO		102, 110, 134	OFDM	BPSK	MCS0
802.11ac 80MHz	MIMO		106	OFDM	BPSK	V0
802.11a	MIMO	5725-5850	149, 157, 165	OFDM	BPSK	6.0
802.11n (20MHz)	MIMO		149, 157, 165	OFDM	BPSK	MCS0
802.11n (40MHz)	MIMO		151, 159	OFDM	BPSK	MCS0
802.11ac 80MHz	MIMO		155	OFDM	BPSK	V0

**Test condition:**

Applicable to	Environmental conditions	Input power	Tested by
RE<1G	27.2deg. C, 55%RH	DC 5V From USB	Tank Tan
RE≥1G	27.2deg. C, 55%RH	DC 5V From USB	Tank Tan
PLC	28.4deg. C, 56%RH	DC 5V From USB	Tank Tan
APCM	28.6deg. C, 55%RH	DC 5V From USB	Harry Li

### 2.3 Duty cycle of test signal

#### Chain 0: Duty cycle of test signal<98%

802.11a Duty cycle of test signal is 97.34%, duty cycle factor= $10 \cdot \log(1/0.9734)=0.11\text{dB}$

802.11n HT20 Duty cycle of test signal is 97.15%, duty cycle factor= $10 \cdot \log(1/0.9715)=0.12\text{dB}$

802.11n HT40 Duty cycle of test signal is 94.34%, duty cycle factor= $10 \cdot \log(1/0.9437)=0.25\text{dB}$

802.11ac VHT80 Duty cycle of test signal is 82.95%, duty cycle factor= $10 \cdot \log(1/0.8295)=0.81\text{dB}$

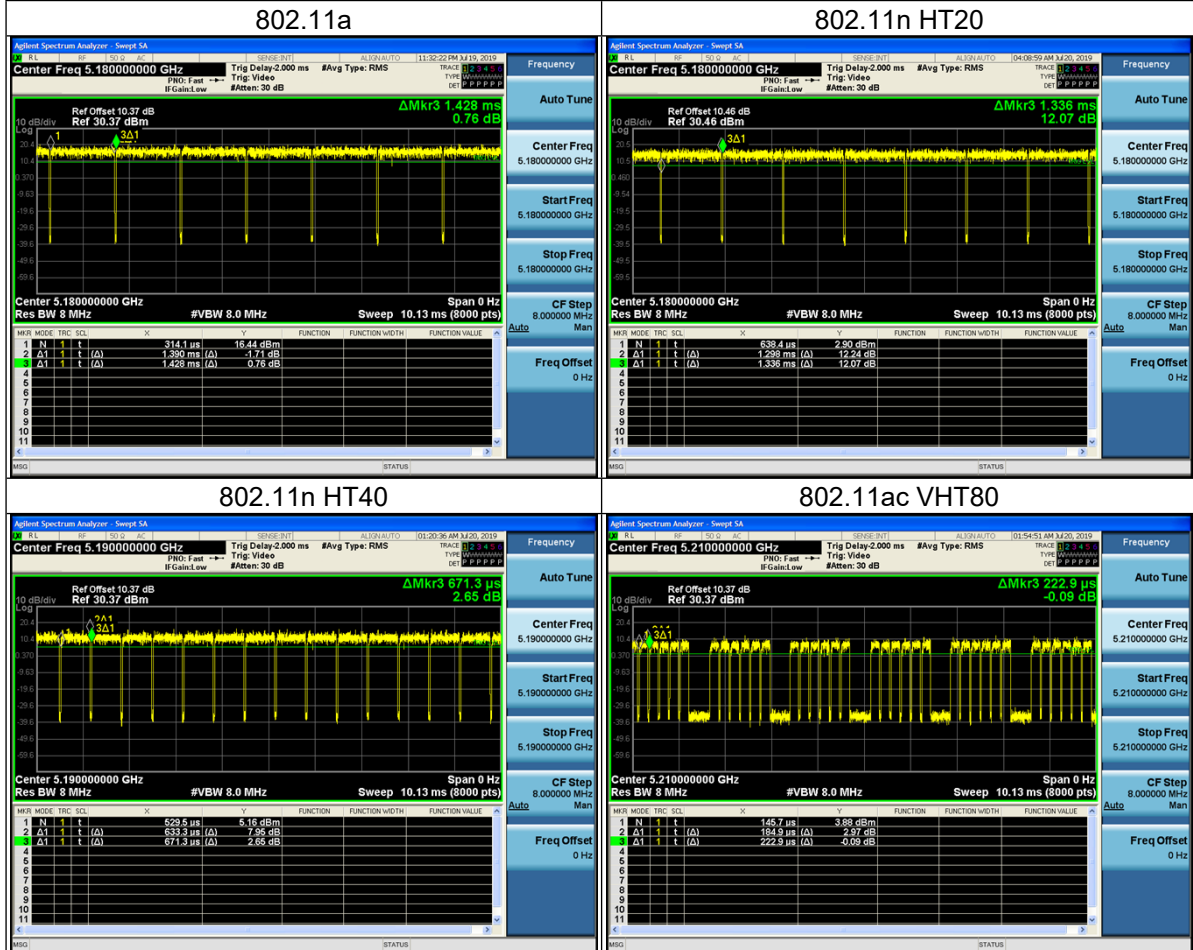

**Chain 1: Duty cycle of test signal<98%**

802.11a Duty cycle of test signal is 97.34%, duty cycle factor= $10 \cdot \log(1/0.9734)=0.11$ dB

802.11n HT20 Duty cycle of test signal is 97.66%, duty cycle factor= $10 \cdot \log(1/0.9766)=0.10$ dB

802.11n HT40 Duty cycle of test signal is 94.43%, duty cycle factor= $10 \cdot \log(1/0.9443)=0.25$ dB

802.11ac VHT80 Duty cycle of test signal is 83.05%, duty cycle factor= $10 \cdot \log(1/0.8305)=0.81$ dB

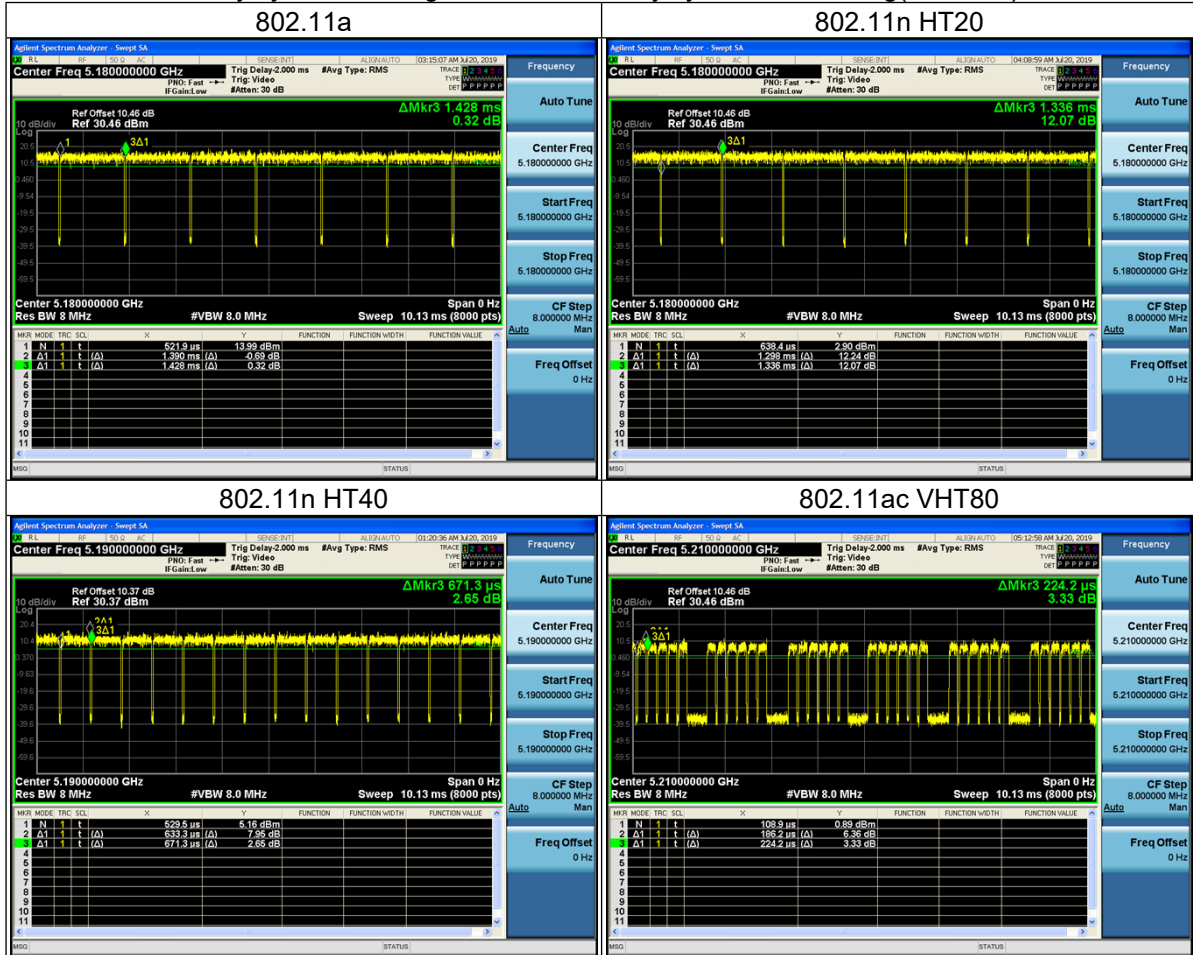

## 2.4 Description of support units

The EUT has been tested as an independent unit together with other necessary accessories or support units. The following support units or accessories were used to form a representative test configuration during the tests.

No.	Product	Brand	Model no.	Serial no.	FCC ID
1	Notebook	Lenovo	TP0093A	PF-12HMBU	N/A
2	Mouse	DELL	MS111-L	CN-09RRC7-44751-0C6-04TR	N/A

No.	Description of the above support units
1	AC Line: Unshielded, Detachable 1.8m; DC Line: Unshielded, Detachable 1.8m;
2	USB Line: Unshielded, Detachable 1.8m.

### Configuration of System under Test:

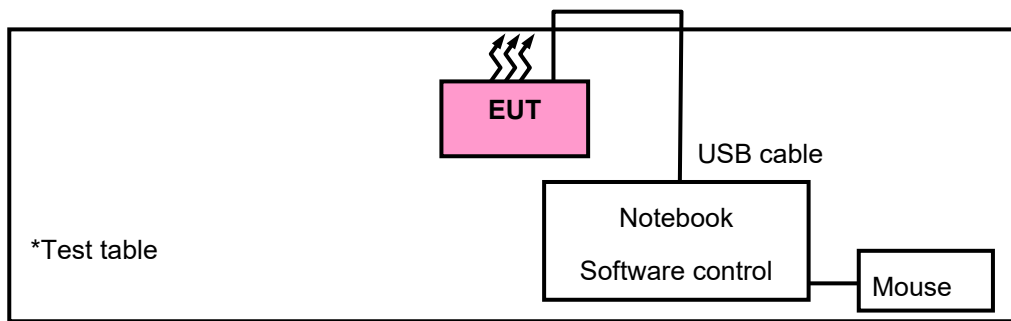

Installed the EUT in the PC and set the EUT under transmission condition continuously at specific channel frequency.

## 2.5 General description of applied standards

The EUT is a RF Product. According to the specification of the EUT declared by the manufacturer, it must comply with the requirements of the following standards:

**FCC Part 15, Subpart E (15.407)**  
**789033 D02 General UNII Test Procedures New Rules v01r03**  
**KDB 662911 D01 v02r01**  
 ANSI C63.10-2013

(All test items have been performed and recorded as per the above standards) .

### **Note:**

The EUT is also considered as a kind of computer peripheral, because the connection to computer is necessary for typical use. It has been verified to comply with the requirements of FCC Part 15.Subpart B. Class B (DoC). The test report has been issued separately.

### 3. Test types and results

#### 3.1 Radiated emission and band-edge measurement

##### 3.1.1 Limits of radiated emission and band-edge measurement

Radiated emissions which fall in the restricted bands must comply with the radiated emission limits specified as below table:

Frequencies (MHz)	Field strength (micro volts/meter)	Measurement distance(meters)
0.009 ~ 0.490	2400/F(kHz)	300
0.490 ~ 1.705	24000/F(kHz)	30
1.705 ~ 30.0	30	30
30 ~ 88	100	3
88 ~ 216	150	3
216 ~ 960	200	3
Above 960	500	3

**Note:**

1. The lower limit shall apply at the transition frequencies.
2. Emission level (dBuV/m) = 20 log Emission level (uV/m).
3. For frequencies above 1000MHz, the field strength limits are based on average detector, however, the peak field strength of any emission shall not exceed the maximum permitted average limits, specified above by more than 30dB under any condition of modulation.

##### 3.1.2 Limits of unwanted emission out of the restricted bands

Applicable to	Limit	
789033 D02 General UNII Test Procedures New Rules v01r03	Field strength at 3m	
	PK: 74 (dBuV/m)	AV: 54 (dBuV/m)
Applicable to	EIRP Limit	Equivalent field strength at 3m
15.407(b)(1)	PK: -27 (dBm/MHz)	PK: 68.2 (dBuV/m)
15.407(b)(2)		
15.407(b)(3)		
15.407(b)(4)	See Note*	See Note*

**Note\*:For transmitters operating in the 5.725-5.85 GHz band:**

Section 15.407(b)(4) specifies the unwanted emissions limit for the U-NII-3 band. A band emissions mask is specified in Section 15.407(b)(4)(i). An alternative to the band emissions mask is specified in Section 15.407(b)(4)(ii). The alternative limits are based on the highest antenna gain specified in the filing. There are also marketing and importation restrictions for the alternative limit.

15.407(b)(4)(i) All emissions shall be limited to a level of -27 dBm/MHz at 75 MHz or more above or below the band edge increasing linearly to 10 dBm/MHz at 25 MHz above or below the band edge, and from 25 MHz above or below the band edge increasing linearly to a level of 15.6 dBm/MHz at 5 MHz above or below the band edge, and from 5 MHz above or below the band edge increasing linearly to a level of 27 dBm/MHz at the band edge.

The following formula is used to convert the equipment isotropic radiated power (eirp) to field strength:

$$E = \frac{1000000\sqrt{30P}}{3} \quad \mu\text{V/m, where P is the eirp (Watts).}$$



### 3.1.3 Test instruments

Description & Manufacturer	Model No.	Serial No.	Date of Calibration	Due Date of Calibration
EMI Test Receiver Rohde&Schwarz	ESCI 7	100962	2019-7-16	2020-7-15
Broadband antenna Schwarzbeck	VULB 9168	00937	2018-11-18	2019-11-17
3m Semi-anechoic Chamber MAORUI	9m*6m*6m	NSEMC003	2018-10-20	2019-10-19
Signal Amplifier Com-power	PAM-103	18020051	2018-11-29	2019-11-28
Attenuator Rohde&Schwarz	TS2GA-6dB	18101101	N/A	N/A
Test software FARAD	FARAD	EZ_EMCV1.1.4.2	N/A	N/A
Fixed Attenuator Mini-Circuits	MDCS18N-10	MDCS18N-10-01	2018-10-17	2019-10-16
Loop Antenna	HLA 6121	45745	2018-10-19	2019-10-18
Preamplifier EMCI	EMC001340	980201	2017-10-22	2019-10-21
Digital Multimeter FLUKE	15B+	43512617WS	2018-11-10	2019-11-09
Horn Antenna Schwarzbeck	BBHA 9170	01959	2018-11-18	2019-11-17
Spectrum Analyzer Rohde&Schwarz	FSV-40N	101783	2018-12-11	2019-12-10
Broadband Coaxial Preamplifier Schwarzbeck	BBV 9718	00025	2018-10-29	2019-10-28
Horn Antenna Schwarzbeck	BBHA 9170	BBHA9170242	2019-05-05	2020-5-04
Pre-Amplifier EMCI	EMC 184045	980102	2018-11-20	2019-11-19
Spectrum Keysight	N9020A	MY51240612	2018-10-29	2019-10-28
Antenna Tower MF	MFA-440H	NA	NA	NA
Turn Table MF	MFT-201SS	NA	NA	NA
Antenna Tower&Turn Table Controller MF	MF-7802	NA	NA	NA

- Note:
1. The calibration interval of the above test instruments is 12 months and the calibrations are traceable to CEPREI/CHINA.
  2. The test was performed in Chamber 1.

### 3.1.4 Test procedures

- a. The EUT was placed on the top of a rotating table 1.5 meters(above 1GHz) and 0.8 meters(below 1GHz) above the ground at a 3 meters semi-anechoic chamber. The table was rotated 360 degrees to determine the position of the highest radiation.
- b. The EUT was set 3 meters away from the interference-receiving antenna, which was mounted on the top of a variable-height antenna tower.
- c. The antenna is a broadband antenna, and its height is varied from one meter to four meters above the ground to determine the maximum value of the field strength. Both horizontal and vertical polarizations of the antenna are set to make the measurement.
- d. For each suspected emission, the EUT was arranged to its worst case and then the antenna was tuned to heights from 1 meter to 4 meters and the rotatable table was turned from 0 degrees to 360 degrees to find the maximum reading.
- e. The test-receiver system was set to Peak Detect Function and Specified Bandwidth with Maximum Hold Mode.
- f. If the emission level of the EUT in peak mode was 10dB lower than the limit specified, then testing could be stopped and the peak values of the EUT would be reported. Otherwise the emissions that did not have 10dB margin would be re-tested one by one using peak, quasi-peak or average method as specified and then reported in a data sheet.
- g. For below 30MHz, a loop antenna with its vertical plane is place 3m from the EUT and rotated about its vertical axis for maximum response at each azimuth about the EUT. And the centre of the loop shall be 1m above the ground.
- h. If the emission level of the EUT in peak mode was lower than the limit specified, then testing could be stopped and the peak values of the EUT would be reported. Otherwise the emissions would be re-tested one by one using peak, quasi-peak or average method as specified and then reported in a data sheet.

#### Note:

1. The resolution bandwidth and video bandwidth of test receiver/spectrum analyzer is 120kHz for Quasi-peak detection at frequency below 1GHz.
2. The resolution bandwidth of test receiver/spectrum analyzer is 1MHz and video bandwidth is 3MHz for Peak detection at frequency above 1GHz.
3. The resolution bandwidth of test receiver/spectrum analyzer is 1MHz and the video bandwidth is  $\geq 1/T$  (Duty cycle < 98%) or 10Hz(Duty cycle > 98%) for Average detection (AV) at frequency above 1GHz.
4. All modes of operation were investigated and the worst-case emissions are reported.

### 3.1.5 Deviation from test standard

No deviation.

### 3.1.6 Test setup

Below 30MHz test setup:

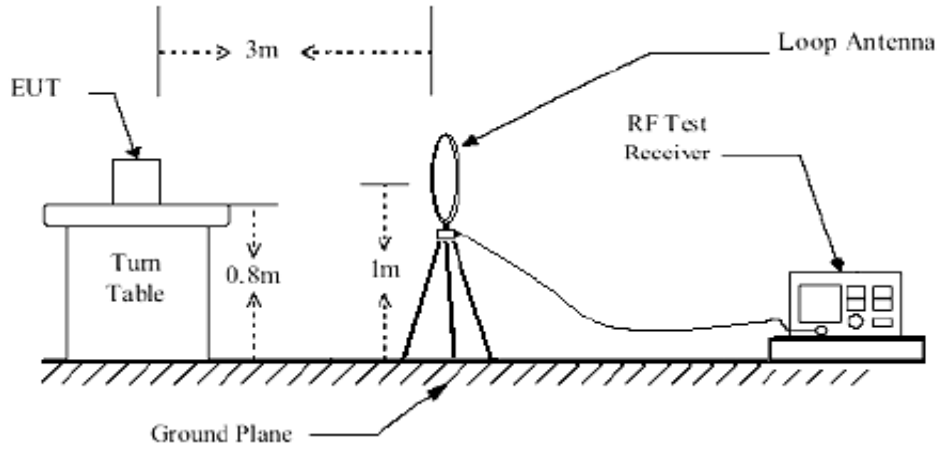

Below 1GHz test setup:

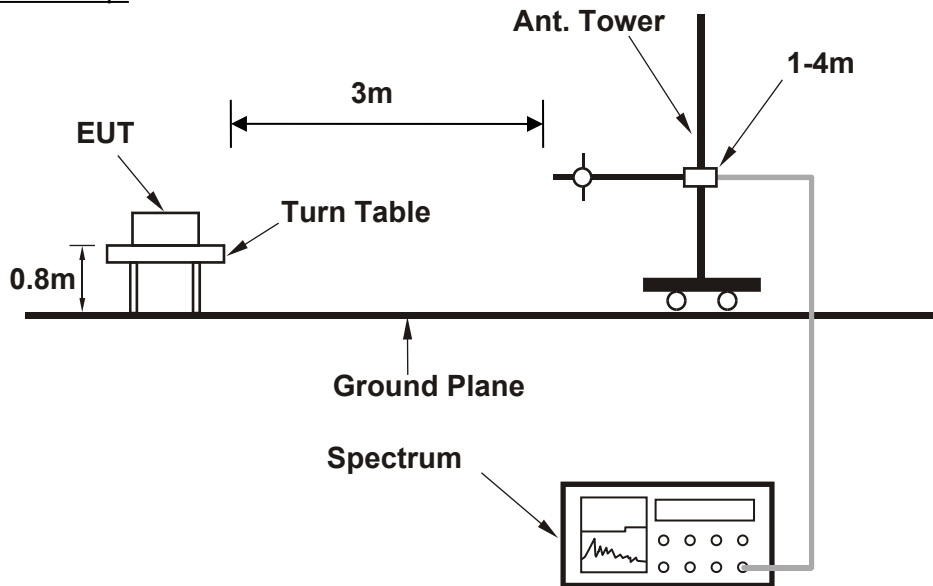

Above 1GHz test setup:

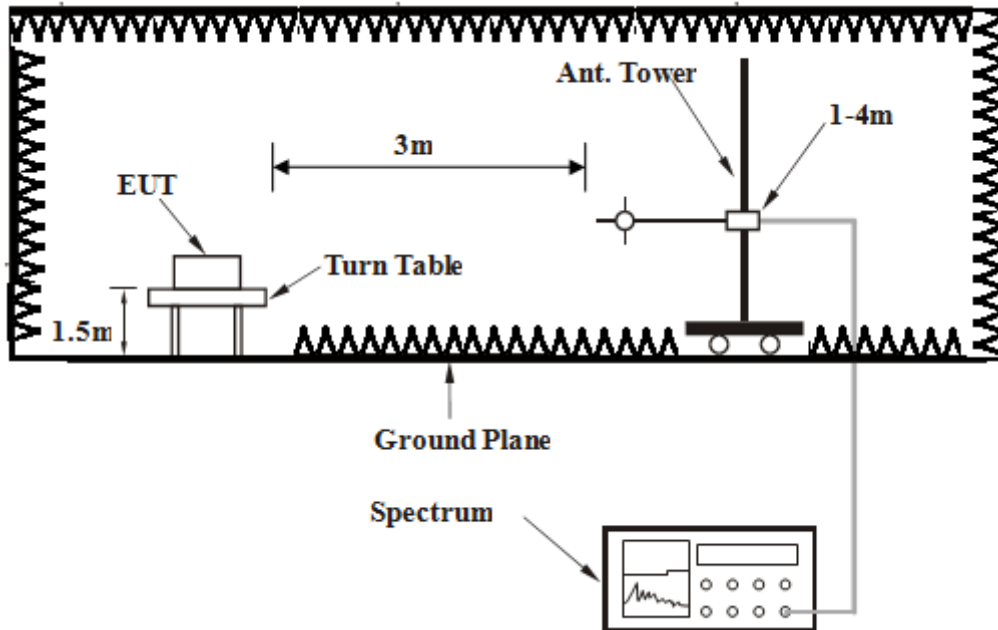

**Note:** For the actual test configuration, please refer to the attached file (Test Setup Photo).

**\*EUT operating condition:**

Installed the EUT in the PC and set the EUT under transmission condition continuously at specific channel frequency.

### 3.1.7 Test results

#### Below 1GHz worst-case data

\*9kHz ~ 30MHz Data:

The amplitude of spurious emissions attenuated more than 20dB below the permissible value is not required to be report.

\*30MHz ~ 1GHz Worst-Case Data:

EUT Test Condition	802.11a TX		
Test Channel	Channel 159	Frequency Range	30MHz ~ 1GHz
Input Power	DC 5V from USB	Detector Function	Peak (PK) Quasi-peak (QP)
Environmental Conditions	25deg. C, 65%RH	Tested By	Tank tan

Antenna Polarity & test distance: horizontal at 3 m

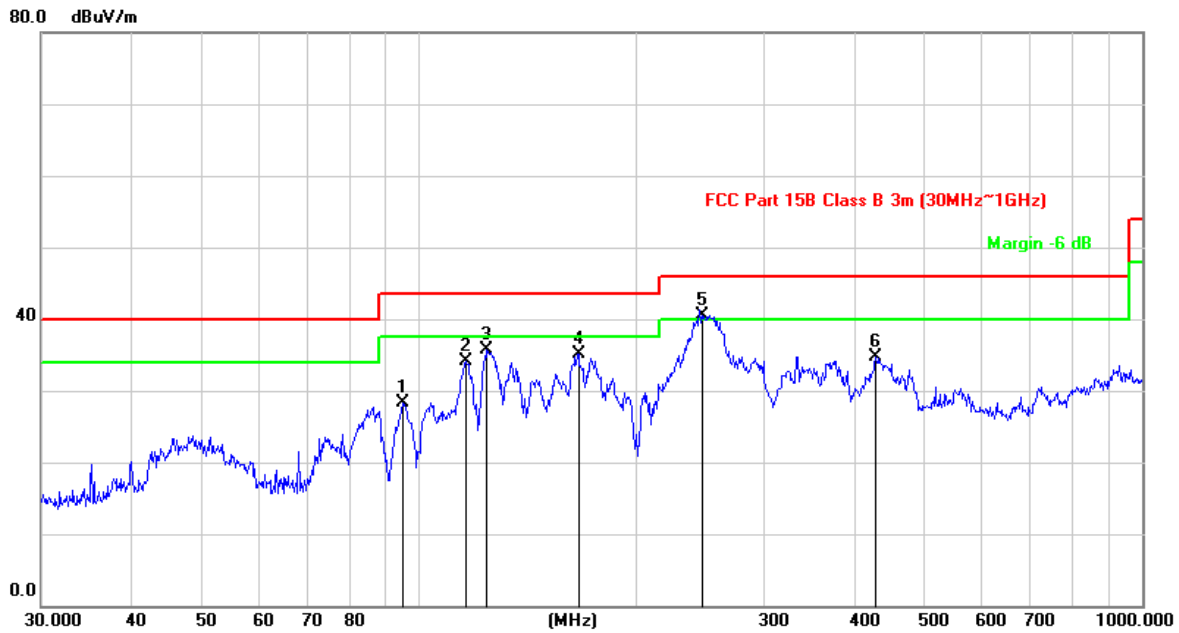

No.	Frequency (MHz)	Reading (dBUV)	Factor (dB)	Emission Level (dBUV/m)	Limit (dBUV/m)	Margin (dB)	Detector	Antenna Height (cm)	Table Angle (Degree)
1	94.7601	47.54	-19.25	28.29	43.50	-15.21	QP	200	274
2	116.1321	49.23	-15.19	34.04	43.50	-9.46	QP	200	223
3	124.1330	50.46	-14.67	35.79	43.50	-7.71	QP	300	290
4	166.0680	48.23	-13.08	35.15	43.50	-8.35	QP	200	175
5	245.9509	55.85	-15.35	40.50	46.00	-5.50	QP	200	10
6	428.0193	43.37	-8.72	34.65	46.00	-11.35	QP	300	320

Remarks:

1. Emission level (dBUV/m) = Raw Value (dBUV) + Correction Factor (dB/m).
2. Factor (dB/m) = Antenna Factor (dB/m) + Cable Factor (dB).
3. The other emission levels were very low against the limit.
4. Margin value = Emission level – Limit value.

EUT Test Condition	802.11a TX		
Channel	Channel 159	Frequency Range	30MHz ~ 1GHz
Input Power	DC 5V from USB	Detector Function	Peak (PK) Quasi-peak (QP)
Environmental Conditions	25deg. C, 65%RH	Tested By	Tank Tan

Antennal Polarity & test distance: vertical at 3 m

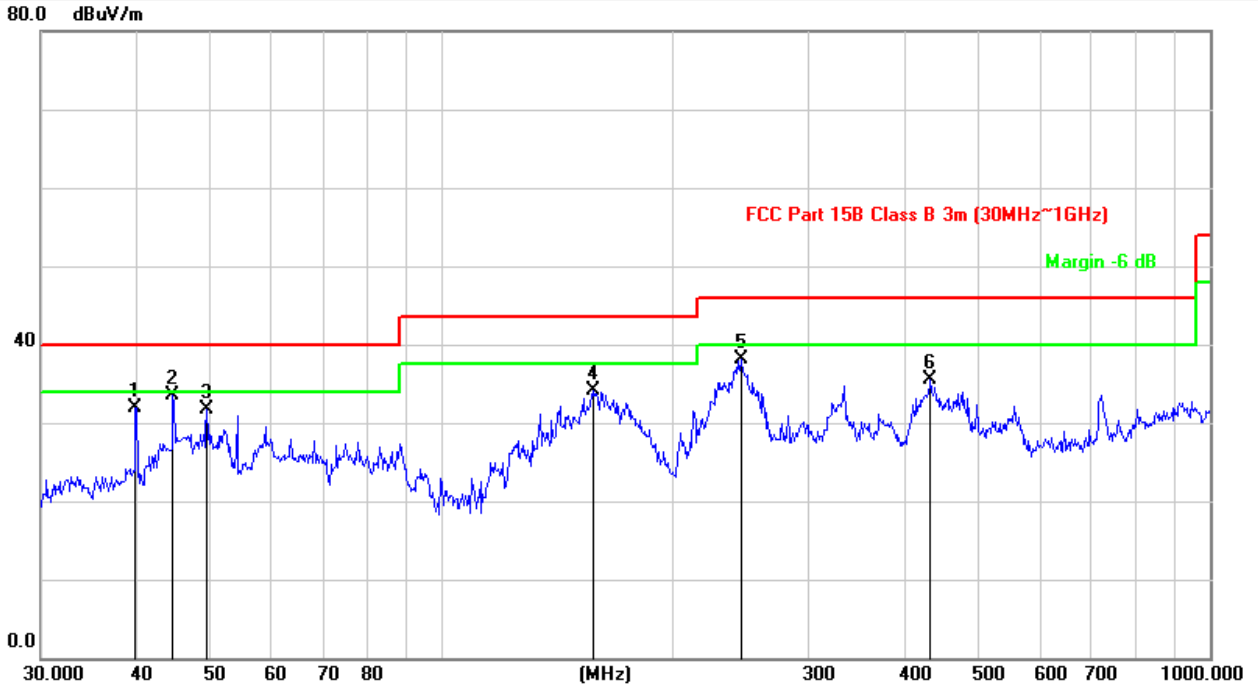

No.	Frequency (MHz)	Reading (dBuV)	Factor (dB)	Emission Level (dBuV/m)	Limit (dBuV/m)	Margin (dB)	Detector	Antenna Height (cm)	Table Angle (Degree)
	39.8542	47.45	-15.57	31.88	40.00	-8.12	QP	100	172
2	44.5868	48.11	-14.62	33.49	40.00	-6.51	QP	150	150
3	49.3594	45.88	-14.21	31.67	40.00	-8.33	QP	100	162
4	157.5588	46.54	-12.52	34.02	43.50	-9.48	QP	100	176
5	245.0900	53.42	-15.36	38.06	46.00	-7.94	QP	100	132
6	432.5457	44.17	-8.74	35.43	46.00	-10.57	QP	100	298

Remarks:

1. Emission level (dBuV/m) = Raw Value (dBuV) + Correction Factor (dB/m).
2. Correction Factor (dB/m) = Antenna Factor (dB/m) + Cable Factor (dB).
3. The other emission levels were very low against the limit.
4. Margin value = Emission level – Limit value.

**Above 1GHz data**
**802.11a**

Test Channel	TX Channel 36	Detector Function	Peak (PK) Average (AV)
Frequency Range	1GHz ~ 40GHz		

Antennal Polarity & Test Distance: Horizontal at 3 m									
No.	Frequency (MHz)	Reading (dBuV)	Factor (dB)	Emission Level (dBuV/m)	Limit (dBuV/m)	Margin (dB)	Detector	Antenna Height (cm)	Table Angle (Degree)
1	5150.000	58.26	7.54	65.80	74.00	-8.20	peak	208	268
2	5150.000	39.11	7.54	46.65	54.00	-7.35	AVG	208	268
3 *	5180.000	107.97	8.49	116.46			peak	208	268
4 *	5180.000	73.53	8.49	82.02			AVG	208	268
5	10360.000	38.79	17.87	56.66	74.00	-17.34	peak	100	247
6	10360.000	21.26	17.87	39.13	54.00	-14.87	AVG	100	247
7	15540.000	37.03	22.25	59.28	74.00	-14.72	peak	100	179
8	15540.000	22.05	22.25	44.30	54.00	-9.70	AVG	100	179
Antennal Polarity & Test Distance: Vertical at 3 m									
No.	Frequency (MHz)	Reading (dBuV)	Factor (dB)	Emission Level (dBuV/m)	Limit (dBuV/m)	Margin (dB)	Detector	Antenna Height (cm)	Table Angle (Degree)
1	5150.000	54.35	7.54	61.89	74.00	-12.11	peak	219	285
2	5150.000	38.20	7.54	45.74	54.00	-8.26	AVG	219	285
3 *	5180.000	102.22	8.49	110.71			peak	219	285
4 *	5180.000	70.26	8.49	78.75			AVG	219	285
5	10360.000	37.30	17.87	55.17	74.00	-18.83	peak	100	100
6	10360.000	21.34	17.87	39.21	54.00	-14.79	AVG	100	100
7	15540.000	38.47	22.25	60.72	74.00	-13.28	peak	100	312
8	15540.000	22.57	22.25	44.82	54.00	-9.18	AVG	100	312

1-Emission level (dBuV/m) = Raw Value (dBuV) + Correction Factor (dB/m).

2-Correction Factor (dB/m) = Antenna Factor (dB/m) + Cable Factor (dB).

3-The other emission levels were very low against the limit.

4-Margin value = Emission level – Limit value.

5- " \* ": Fundamental frequency.

Test Channel	TX Channel 44	Detector Function	Peak (PK) Average (AV)
Frequency Range	1GHz ~ 40GHz		

Antennal Polarity & Test Distance: Horizontal at 3 m									
No.	Frequency (MHz)	Reading (dBuV)	Factor (dB)	Emission Level (dBuV/m)	Limit (dBuV/m)	Margin (dB)	Detector	Antenna Height (cm)	Table Angle (Degree)
1	5150.000	53.06	7.54	60.60	74.00	-13.40	peak	238	269
2	5150.000	38.48	7.54	46.02	54.00	-7.98	AVG	238	269
3 *	5200.000	108.16	9.12	117.28			peak	238	269
4 *	5200.000	73.14	9.12	82.26			AVG	238	269
5	10400.000	38.94	18.00	56.94	74.00	-17.06	peak	100	236
6	10400.000	23.92	18.00	41.92	54.00	-12.08	AVG	100	236
7	15600.000	36.77	22.23	59.00	74.00	-15.00	peak	100	310
8	15600.000	21.73	22.23	43.96	54.00	-10.04	AVG	100	310
Antennal Polarity & Test Distance: Vertical at 3 m									
No.	Frequency (MHz)	Reading (dBuV)	Factor (dB)	Emission Level (dBuV/m)	Limit (dBuV/m)	Margin (dB)	Detector	Antenna Height (cm)	Table Angle (Degree)
1	5150.000	49.89	7.54	57.43	74.00	-16.57	peak	100	274
2	5150.000	34.96	7.54	42.50	54.00	-11.50	AVG	100	274
3 *	5200.000	102.22	9.12	111.34			peak	100	274
4 *	5200.000	70.69	9.12	79.81			AVG	100	274
5	10400.000	36.83	18.00	54.83	74.00	-19.17	peak	100	178
6	10400.000	22.39	18.00	40.39	54.00	-13.61	AVG	100	178
7	15600.000	36.52	22.23	58.75	74.00	-15.25	peak	100	275
8	15600.000	21.90	22.23	44.13	54.00	-9.87	AVG	100	275

1-Emission level (dBuV/m) = Raw Value (dBuV) + Correction Factor (dB/m).

2-Correction Factor (dB/m) = Antenna Factor (dB/m) + Cable Factor (dB).

3-The other emission levels were very low against the limit.

4-Margin value = Emission level – Limit value.

5- " \* ": Fundamental frequency.



Test Channel	TX Channel 48	Detector Function	Peak (PK) Average (AV)
Frequency Range	1GHz ~ 40GHz		

Antennal Polarity & Test Distance: Horizontal at 3 m									
No.	Frequency (MHz)	Reading (dBuV)	Factor (dB)	Emission Level (dBuV/m)	Limit (dBuV/m)	Margin (dB)	Detector	Antenna Height (cm)	Table Angle (Degree)
1 *	5240.000	108.76	7.97	116.73			peak	236	272
2 *	5240.000	73.83	7.97	81.80			AVG	236	272
3	10480.000	39.29	18.26	57.55	74.00	-16.45	peak	100	240
4	10480.000	22.82	18.26	41.08	54.00	-12.92	AVG	100	240
5	15720.000	35.43	22.19	57.62	74.00	-16.38	peak	100	190
6	15720.000	21.09	22.19	43.28	54.00	-10.72	AVG	100	190
Antennal Polarity & Test Distance: Vertical at 3 m									
No.	Frequency (MHz)	Reading (dBuV)	Factor (dB)	Emission Level (dBuV/m)	Limit (dBuV/m)	Margin (dB)	Detector	Antenna Height (cm)	Table Angle (Degree)
1 *	5240.000	102.37	7.97	110.34			peak	157	283
2 *	5240.000	67.19	7.97	75.16			AVG	157	283
3	10480.000	37.43	18.26	55.69	74.00	-18.31	peak	100	134
4	10480.000	22.48	18.26	40.74	54.00	-13.26	AVG	100	134
5	15720.000	35.40	22.19	57.59	74.00	-16.41	peak	100	360
6	15720.000	20.68	22.19	42.87	54.00	-11.13	AVG	100	360

- 1-Emission level (dBuV/m) = Raw Value (dBuV) + Correction Factor (dB/m).
- 2-Correction Factor (dB/m) = Antenna Factor (dB/m) + Cable Factor (dB).
- 3-The other emission levels were very low against the limit.
- 4-Margin value = Emission level – Limit value.
- 5- " \* ": Fundamental frequency.

Test Channel	TX Channel 52	Detector Function	Peak (PK) Average (AV)
Frequency Range	1GHz ~ 40GHz		

Antennal Polarity & Test Distance: Horizontal at 3 m									
No.	Frequency (MHz)	Reading (dBuV)	Factor (dB)	Emission Level (dBuV/m)	Limit (dBuV/m)	Margin (dB)	Detector	Antenna Height (cm)	Table Angle (Degree)
1 *	5260.000	108.86	7.41	116.27			peak	220	267
2 *	5260.000	73.92	7.41	81.33			AVG	220	267
3	10520.000	38.56	18.36	56.92	74.00	-17.08	peak	100	119
4	10520.000	22.35	18.36	40.71	54.00	-13.29	AVG	100	119
5	15780.000	36.44	22.17	58.61	74.00	-15.39	peak	100	300
6	15780.000	21.83	22.17	44.00	54.00	-10.00	AVG	100	300
Antennal Polarity & Test Distance: Vertical at 3 m									
No.	Frequency (MHz)	Reading (dBuV)	Factor (dB)	Emission Level (dBuV/m)	Limit (dBuV/m)	Margin (dB)	Detector	Antenna Height (cm)	Table Angle (Degree)
1 *	5260.000	103.88	7.41	111.29			peak	121	225
2 *	5260.000	69.99	7.41	77.40			AVG	121	225
3	10520.000	33.97	18.36	52.33	74.00	-21.67	peak	100	204
4	10520.000	20.00	18.36	38.36	54.00	-15.64	AVG	100	204
5	15780.000	36.29	22.17	58.46	74.00	-15.54	peak	100	285
6	15780.000	21.81	22.17	43.98	54.00	-10.02	AVG	100	285

1-Emission level (dBuV/m) = Raw Value (dBuV) + Correction Factor (dB/m).

2-Correction Factor (dB/m) = Antenna Factor (dB/m) + Cable Factor (dB).

3-The other emission levels were very low against the limit.

4-Margin value = Emission level – Limit value.

5- " \* ": Fundamental frequency.

Test Channel	TX Channel 60	Detector Function	Peak (PK) Average (AV)
Frequency Range	1GHz ~ 40GHz		

Antennal Polarity & Test Distance: Horizontal at 3 m									
No.	Frequency (MHz)	Reading (dBuV)	Factor (dB)	Emission Level (dBuV/m)	Limit (dBuV/m)	Margin (dB)	Detector	Antenna Height (cm)	Table Angle (Degree)
1 *	5300.000	109.45	6.26	115.71			peak	212	268
2 *	5300.000	74.10	6.26	80.36			AVG	212	268
3	5350.000	53.60	6.34	59.94	74.00	-14.06	peak	212	268
4	5350.000	40.09	6.34	46.43	54.00	-7.57	AVG	212	268
5	10600.000	41.01	18.52	59.53	74.00	-14.47	peak	100	125
6	10600.000	24.19	18.52	42.71	54.00	-11.29	AVG	100	125
7	15900.000	37.17	22.13	59.30	74.00	-14.70	peak	100	270
8	15900.000	23.02	22.13	45.15	54.00	-8.85	AVG	100	270
Antennal Polarity & Test Distance: Vertical at 3 m									
No.	Frequency (MHz)	Reading (dBuV)	Factor (dB)	Emission Level (dBuV/m)	Limit (dBuV/m)	Margin (dB)	Detector	Antenna Height (cm)	Table Angle (Degree)
1 *	5300.000	93.77	6.26	100.03			peak	100	229
2 *	5300.000	68.61	6.26	74.87			AVG	100	229
3	5350.000	52.13	6.34	58.47	74.00	-15.53	peak	100	229
4	5350.000	39.47	6.34	45.81	54.00	-8.19	AVG	100	229
5	10600.000	40.20	18.52	58.72	74.00	-15.28	peak	100	135
6	10600.000	22.86	18.52	41.38	54.00	-12.62	AVG	100	135
7	15900.000	37.14	22.13	59.27	74.00	-14.73	peak	100	344
8	15900.000	22.90	22.13	45.03	54.00	-8.97	AVG	100	344

1-Emission level (dBuV/m) = Raw Value (dBuV) + Correction Factor (dB/m).

2-Correction Factor (dB/m) = Antenna Factor (dB/m) + Cable Factor (dB).

3-The other emission levels were very low against the limit.

4-Margin value = Emission level – Limit value.

5- " \* ": Fundamental frequency.

Test Channel	TX Channel 64	Detector Function	Peak (PK) Average (AV)
Frequency Range	1GHz ~ 40GHz		

Antennal Polarity & Test Distance: Horizontal at 3 m									
No.	Frequency (MHz)	Reading (dBuV)	Factor (dB)	Emission Level (dBuV/m)	Limit (dBuV/m)	Margin (dB)	Detector	Antenna Height (cm)	Table Angle (Degree)
1 *	5320.000	109.00	6.29	115.29			peak	201	271
2 *	5320.000	74.96	6.29	81.25			AVG	201	271
3	5350.000	59.40	6.34	65.74	74.00	-8.26	peak	201	271
4	5350.000	40.68	6.34	47.02	54.00	-6.98	AVG	201	271
5	10640.000	41.13	18.60	59.73	74.00	-14.27	peak	212	121
6	10640.000	23.88	18.60	42.48	54.00	-11.52	AVG	212	121
7	15960.000	36.80	22.11	58.91	74.00	-15.09	peak	100	305
8	15960.000	22.67	22.11	44.78	54.00	-9.22	AVG	100	305
Antennal Polarity & Test Distance: Vertical at 3 m									
No.	Frequency (MHz)	Reading (dBuV)	Factor (dB)	Emission Level (dBuV/m)	Limit (dBuV/m)	Margin (dB)	Detector	Antenna Height (cm)	Table Angle (Degree)
1 *	5320.000	104.30	6.29	110.59			peak	113	229
2 *	5320.000	71.34	6.29	77.63			AVG	113	229
3	5350.000	55.13	6.34	61.47	74.00	-12.53	peak	113	229
4	5350.000	36.92	6.34	43.26	54.00	-10.74	AVG	113	229
5	10640.000	37.77	18.60	56.37	74.00	-17.63	peak	100	156
6	10640.000	22.40	18.60	41.00	54.00	-13.00	AVG	100	156
7	15960.000	36.98	22.11	59.09	74.00	-14.91	peak	100	292
8	15960.000	22.64	22.11	44.75	54.00	-9.25	AVG	100	292

1-Emission level (dBuV/m) = Raw Value (dBuV) + Correction Factor (dB/m).

2-Correction Factor (dB/m) = Antenna Factor (dB/m) + Cable Factor (dB).

3-The other emission levels were very low against the limit.

4-Margin value = Emission level – Limit value.

5- " \* ": Fundamental frequency.

Test Channel	TX Channel 100	Detector Function	Peak (PK) Average (AV)
Frequency Range	1GHz ~ 40GHz		

Antennal Polarity & Test Distance: Horizontal at 3 m									
No.	Frequency (MHz)	Reading (dBuV)	Factor (dB)	Emission Level (dBuV/m)	Limit (dBuV/m)	Margin (dB)	Detector	Antenna Height (cm)	Table Angle (Degree)
1	5460.000	53.17	6.34	59.51	74.00	-14.49	peak	180	260
2	5460.000	40.07	6.34	46.41	54.00	-7.59	AVG	180	260
3	5470.000	58.40	6.50	64.90	68.20	-3.30	peak	215	269
4 *	5500.000	110.98	6.54	117.52			peak	215	269
5 *	5500.000	75.17	6.54	81.71			AVG	215	269
6	11000.000	41.62	19.32	60.94	74.00	-13.06	peak	100	218
7	11000.000	24.07	19.32	43.39	54.00	-10.61	AVG	100	218
8	16500.000	38.04	23.34	61.38	74.00	-12.62	peak	100	315
9	16500.000	22.44	23.34	45.78	54.00	-8.22	AVG	100	315
Antennal Polarity & Test Distance: Vertical at 3 m									
No.	Frequency (MHz)	Reading (dBuV)	Factor (dB)	Emission Level (dBuV/m)	Limit (dBuV/m)	Margin (dB)	Detector	Antenna Height (cm)	Table Angle (Degree)
1	5460.000	49.56	6.34	55.9	74.00	-18.10	peak	150	216
2	5460.000	38.04	6.34	44.38	54.00	-9.62	AVG	150	216
3	5470.000	53.87	6.50	60.37	68.20	-7.83	peak	137	244
4 *	5500.000	106.30	6.54	112.84			peak	137	244
5 *	5500.000	72.08	6.54	78.62			AVG	137	244
6	11000.000	38.88	19.32	58.20	74.00	-15.80	peak	100	103
7	11000.000	22.21	19.32	41.53	54.00	-12.47	AVG	100	103
8	16500.000	37.91	23.34	61.25	74.00	-12.75	peak	100	335
9	16500.000	22.33	23.34	45.67	54.00	-8.33	AVG	100	335

1-Emission level (dBuV/m) = Raw Value (dBuV) + Correction Factor (dB/m).

2-Correction Factor (dB/m) = Antenna Factor (dB/m) + Cable Factor (dB).

3-The other emission levels were very low against the limit.

4-Margin value = Emission level – Limit value.

5- " \* ": Fundamental frequency.

Test Channel	TX Channel 120	Detector Function	Peak (PK) Average (AV)
Frequency Range	1GHz ~ 40GHz		

Antennal Polarity & Test Distance: Horizontal at 3 m									
No.	Frequency (MHz)	Reading (dBuV)	Factor (dB)	Emission Level (dBuV/m)	Limit (dBuV/m)	Margin (dB)	Detector	Antenna Height (cm)	Table Angle (Degree)
1	5470.000	54.66	6.50	61.16	68.20	-7.04	peak	221	267
2 *	5600.000	109.44	6.72	116.16			peak	221	267
3 *	5600.000	74.59	6.72	81.31			AVG	221	267
4	11200.000	39.54	19.51	59.05	74.00	-14.95	peak	126	232
5	11200.000	24.35	19.51	43.86	54.00	-10.14	AVG	126	232
6	16800.000	37.51	24.44	61.95	74.00	-12.05	peak	100	114
7	16800.000	22.96	24.44	47.40	54.00	-6.60	AVG	100	114
Antennal Polarity & Test Distance: Vertical at 3 m									
No.	Frequency (MHz)	Reading (dBuV)	Factor (dB)	Emission Level (dBuV/m)	Limit (dBuV/m)	Margin (dB)	Detector	Antenna Height (cm)	Table Angle (Degree)
1	5470.000	53.16	6.50	59.66	68.20	-8.54	peak	100	230
2 *	5600.000	105.02	6.72	111.74			peak	100	230
3 *	5600.000	72.23	6.72	78.95			AVG	100	230
4	11200.000	36.62	19.51	56.13	74.00	-17.87	peak	100	185
5	11200.000	21.19	19.51	40.70	54.00	-13.30	AVG	100	185
6	16800.000	37.40	24.44	61.84	74.00	-12.16	peak	100	308
7	16800.000	22.82	24.44	47.26	54.00	-6.74	AVG	100	308

1-Emission level (dBuV/m) = Raw Value (dBuV) + Correction Factor (dB/m).

2-Correction Factor (dB/m) = Antenna Factor (dB/m) + Cable Factor (dB).

3-The other emission levels were very low against the limit.

4-Margin value = Emission level – Limit value.

5- " \* ": Fundamental frequency.

Test Channel	TX Channel 140	Detector Function	Peak (PK) Average (AV)
Frequency Range	1GHz ~ 40GHz		

Antennal Polarity & Test Distance: Horizontal at 3 m									
No.	Frequency (MHz)	Reading (dBuV)	Factor (dB)	Emission Level (dBuV/m)	Limit (dBuV/m)	Margin (dB)	Detector	Antenna Height (cm)	Table Angle (Degree)
1 *	5700.000	108.77	6.92	115.69			peak	283	222
2 *	5700.000	76.64	6.92	83.56			AVG	283	222
3 #	5725.000	59.42	6.96	66.38	68.20	-1.82	peak	283	222
4	11400.000	35.61	19.68	55.29	74.00	-18.71	peak	100	146
5	11400.000	20.77	19.68	40.45	54.00	-13.55	AVG	100	146
6	17100.000	35.22	25.59	60.81	74.00	-13.19	peak	100	317
7	17100.000	21.03	25.59	46.62	54.00	-7.38	AVG	100	317
Antennal Polarity & Test Distance: Vertical at 3 m									
No.	Frequency (MHz)	Reading (dBuV)	Factor (dB)	Emission Level (dBuV/m)	Limit (dBuV/m)	Margin (dB)	Detector	Antenna Height (cm)	Table Angle (Degree)
1 *	5700.000	93.45	6.92	100.37			peak	210	246
2 *	5700.000	72.61	6.92	79.53			AVG	210	246
3 #	5725.000	55.21	6.96	62.17	68.20	-6.03	peak	210	246
4	11400.000	35.20	19.68	54.88	74.00	-19.12	peak	100	234
5	11400.000	20.56	19.68	40.24	54.00	-13.76	AVG	100	234
6	17100.000	35.32	25.59	60.91	74.00	-13.09	peak	100	290
7	17100.000	20.79	25.59	46.38	54.00	-7.62	AVG	100	290

1-Emission level (dBuV/m) = Raw Value (dBuV) + Correction Factor (dB/m).

2-Correction Factor (dB/m) = Antenna Factor (dB/m) + Cable Factor (dB).

3-The other emission levels were very low against the limit.

4-Margin value = Emission level – Limit value.

5- " \* ": Fundamental frequency.

6- " # ": The radiated frequency is out of the restricted band

Test Channel	TX Channel 149	Detector Function	Peak (PK) Average (AV)
Frequency Range	1GHz ~ 40GHz		

Antennal Polarity & Test Distance: Horizontal at 3 m									
No.	Frequency (MHz)	Reading (dBuV)	Factor (dB)	Emission Level (dBuV/m)	Limit (dBuV/m)	Margin (dB)	Detector	Antenna Height (cm)	Table Angle (Degree)
1	5650.000	52.81	6.82	59.63	68.20	-8.57	peak	185	40
2 #	5725.000	70.99	6.96	77.95	122.20	-44.25	peak	210	317
3 *	5745.000	110.13	6.99	117.12			peak	210	317
4 *	5745.000	74.71	6.99	81.70			AVG	210	317
5	11490.000	39.86	19.77	59.63	74.00	-14.37	peak	178	234
6	11490.000	24.41	19.77	44.18	54.00	-9.82	AVG	178	234
7	17235.000	35.81	26.17	61.98	74.00	-12.02	peak	100	350
8	17235.000	20.86	26.17	47.03	54.00	-6.97	AVG	100	350
Antennal Polarity & Test Distance: Vertical at 3 m									
No.	Frequency (MHz)	Reading (dBuV)	Factor (dB)	Emission Level (dBuV/m)	Limit (dBuV/m)	Margin (dB)	Detector	Antenna Height (cm)	Table Angle (Degree)
1	5650.000	48.06	6.82	54.88	68.20	-13.32	peak	131	264
2 #	5725.000	67.39	6.96	74.35	122.20	-47.85	peak	131	264
3 *	5745.000	106.60	6.99	113.59			peak	131	264
4 *	5745.000	70.54	6.99	77.53			AVG	131	264
5	11490.000	37.67	19.77	57.44	74.00	-16.56	peak	100	283
6	11490.000	22.33	19.77	42.10	54.00	-11.90	AVG	100	283
7	17235.000	35.59	26.17	61.76	74.00	-12.24	peak	100	300
8	17235.000	20.80	26.17	46.97	54.00	-7.03	AVG	100	300

1-Emission level (dBuV/m) = Raw Value (dBuV) + Correction Factor (dB/m).

2-Correction Factor (dB/m) = Antenna Factor (dB/m) + Cable Factor (dB).

3-The other emission levels were very low against the limit.

4-Margin value = Emission level – Limit value.

5- " \* ": Fundamental frequency.

6- " # ": The radiated frequency is out of the restricted band



Test Channel	TX Channel 157	Detector Function	Peak (PK) Average (AV)
Frequency Range	1GHz ~ 40GHz		

Antennal Polarity & Test Distance: Horizontal at 3 m									
No.	Frequency (MHz)	Reading (dBuV)	Factor (dB)	Emission Level (dBuV/m)	Limit (dBuV/m)	Margin (dB)	Detector	Antenna Height (cm)	Table Angle (Degree)
1 #	5725.000	54.42	6.96	61.38	122.20	-60.82	peak	194	229
2 *	5785.000	110.84	7.07	117.91			peak	194	229
3 *	5785.000	75.31	7.07	82.38			AVG	194	229
4	5850.000	53.16	7.20	60.36	122.20	-61.84	peak	194	229
5	11570.000	40.49	19.75	60.24	74.00	-13.76	peak	155	238
6	11570.000	25.92	19.75	45.67	54.00	-8.33	AVG	155	238
7	17355.000	35.01	26.68	61.69	74.00	-12.31	peak	100	76
8	17355.000	20.13	26.68	46.81	54.00	-7.19	AVG	100	76
Antennal Polarity & Test Distance: Vertical at 3 m									
No.	Frequency (MHz)	Reading (dBuV)	Factor (dB)	Emission Level (dBuV/m)	Limit (dBuV/m)	Margin (dB)	Detector	Antenna Height (cm)	Table Angle (Degree)
1 #	5725.000	55.35	6.96	62.31	122.20	-59.89	peak	100	272
2 *	5785.000	107.06	7.07	114.13			peak	100	272
3 *	5785.000	71.55	7.07	78.62			AVG	100	272
4	5850.000	53.65	7.20	60.85	122.20	-61.35	peak	100	272
5	11570.000	37.55	19.75	57.30	74.00	-16.70	peak	100	169
6	11570.000	23.11	19.75	42.86	54.00	-11.14	AVG	100	169
7	17355.000	34.69	26.68	61.37	74.00	-12.63	peak	100	351
8	17355.000	20.10	26.68	46.78	54.00	-7.22	AVG	100	351

1-Emission level (dBuV/m) = Raw Value (dBuV) + Correction Factor (dB/m).

2-Correction Factor (dB/m) = Antenna Factor (dB/m) + Cable Factor (dB).

3-The other emission levels were very low against the limit.

4-Margin value = Emission level – Limit value.

5- " \* ": Fundamental frequency.

6- " # ": The radiated frequency is out of the restricted band

Test Channel	TX Channel 165	Detector Function	Peak (PK) Average (AV)
Frequency Range	1GHz ~ 40GHz		

Antennal Polarity & Test Distance: Horizontal at 3 m									
No.	Frequency (MHz)	Reading (dBuV)	Factor (dB)	Emission Level (dBuV/m)	Limit (dBuV/m)	Margin (dB)	Detector	Antenna Height (cm)	Table Angle (Degree)
1 *	5825.000	108.81	7.15	115.96			peak	212	224
2 *	5825.000	76.29	7.15	83.44			AVG	212	224
3	5850.000	67.10	7.20	74.30	122.20	-47.90	peak	212	224
4	11650.000	41.51	19.72	61.23	74.00	-12.77	peak	184	202
5	11650.000	26.48	19.72	46.20	54.00	-7.80	AVG	184	202
6	17475.000	34.05	27.19	61.24	74.00	-12.76	peak	100	295
7	17475.000	17.13	27.19	44.32	54.00	-9.68	AVG	100	295
Antennal Polarity & Test Distance: Vertical at 3 m									
No.	Frequency (MHz)	Reading (dBuV)	Factor (dB)	Emission Level (dBuV/m)	Limit (dBuV/m)	Margin (dB)	Detector	Antenna Height (cm)	Table Angle (Degree)
1 *	5825.000	104.73	7.15	111.88			peak	163	265
2 *	5825.000	72.52	7.15	79.67			AVG	163	265
3	5850.000	64.34	7.20	71.54	122.20	-50.66	peak	163	265
4	11650.000	37.81	19.72	57.53	74.00	-16.47	peak	100	254
5	11650.000	22.67	19.72	42.39	54.00	-11.61	AVG	100	254
6	17475.000	33.98	27.19	61.17	74.00	-12.83	peak	100	335
7	17475.000	17.07	27.19	44.26	54.00	-9.74	AVG	100	335

1-Emission level (dBuV/m) = Raw Value (dBuV) + Correction Factor (dB/m).

2-Correction Factor (dB/m) = Antenna Factor (dB/m) + Cable Factor (dB).

3-The other emission levels were very low against the limit.

4-Margin value = Emission level – Limit value.

5- " \* ": Fundamental frequency.

11n HT20

Test Channel	TX Channel 36	Detector Function	Peak (PK) Average (AV)
Frequency Range	1GHz ~ 40GHz		

Antennal Polarity & Test Distance: Horizontal at 3 m

No.	Frequency (MHz)	Reading (dBuV)	Factor (dB)	Emission Level (dBuV/m)	Limit (dBuV/m)	Margin (dB)	Detector	Antenna Height (cm)	Table Angle (Degree)
1	5150.000	53.45	7.54	60.99	74.00	-13.01	peak	213	269
2	5150.000	38.81	7.54	46.35	54.00	-7.65	AVG	213	269
3 *	5180.000	105.35	8.49	113.84			peak	213	269
4 *	5180.000	69.89	8.49	78.38			AVG	213	269
5	10360.000	40.76	17.87	58.63	74.00	-15.37	peak	138	226
6	10360.000	24.02	17.87	41.89	54.00	-12.11	AVG	138	226
7	15540.000	36.20	22.25	58.45	74.00	-15.55	peak	100	104
8	15540.000	21.94	22.25	44.19	54.00	-9.81	AVG	100	104

Antennal Polarity & Test Distance: Vertical at 3 m

No.	Frequency (MHz)	Reading (dBuV)	Factor (dB)	Emission Level (dBuV/m)	Limit (dBuV/m)	Margin (dB)	Detector	Antenna Height (cm)	Table Angle (Degree)
1	5150.000	52.78	7.54	60.32	74.00	-13.68	peak	100	269
2	5150.000	37.97	7.54	45.51	54.00	-8.49	AVG	100	269
3 *	5180.000	100.62	8.49	109.11			peak	100	269
4 *	5180.000	67.67	8.49	76.16			AVG	100	269
5	10360.000	38.40	17.87	56.27	74.00	-17.73	peak	100	147
6	10360.000	22.32	17.87	40.19	54.00	-13.81	AVG	100	147
7	15540.000	35.98	22.25	58.23	74.00	-15.77	peak	100	337
8	15540.000	21.89	22.25	44.14	54.00	-9.86	AVG	100	337

1-Emission level (dBuV/m) = Raw Value (dBuV) + Correction Factor (dB/m).

2-Correction Factor (dB/m) = Antenna Factor (dB/m) + Cable Factor (dB).

3-The other emission levels were very low against the limit.

4-Margin value = Emission level – Limit value.

5- " \* ": Fundamental frequency.

Test Channel	TX Channel 44	Detector Function	Peak (PK) Average (AV)
Frequency Range	1GHz ~ 40GHz		

Antennal Polarity & Test Distance: Horizontal at 3 m									
No.	Frequency (MHz)	Reading (dBuV)	Factor (dB)	Emission Level (dBuV/m)	Limit (dBuV/m)	Margin (dB)	Detector	Antenna Height (cm)	Table Angle (Degree)
1	5150.000	52.36	7.54	59.90	74.00	-14.10	peak	234	269
2	5150.000	39.06	7.54	46.60	54.00	-7.40	AVG	234	269
3 *	5200.000	104.97	9.12	114.09			peak	234	269
4 *	5200.000	69.23	9.12	78.35			AVG	234	269
5	10400.000	41.04	18.00	59.04	74.00	-14.96	peak	100	267
6	10400.000	25.62	18.00	43.62	54.00	-10.38	AVG	100	267
7	15600.000	36.69	22.23	58.92	74.00	-15.08	peak	100	15
8	15600.000	21.57	22.23	43.80	54.00	-10.20	AVG	100	15
Antennal Polarity & Test Distance: Vertical at 3 m									
No.	Frequency (MHz)	Reading (dBuV)	Factor (dB)	Emission Level (dBuV/m)	Limit (dBuV/m)	Margin (dB)	Detector	Antenna Height (cm)	Table Angle (Degree)
1	5150.000	48.93	7.54	56.47	74.00	-17.53	peak	100	253
2	5150.000	35.66	7.54	43.20	54.00	-10.80	AVG	100	253
3 *	5200.000	90.75	9.12	99.87			peak	100	253
4 *	5200.000	65.51	9.12	74.63			AVG	100	253
5	10400.000	39.46	18.00	57.46	74.00	-16.54	peak	100	142
6	10400.000	23.15	18.00	41.15	54.00	-12.85	AVG	100	142
7	15600.000	36.91	22.23	59.14	74.00	-14.86	peak	100	318
8	15600.000	21.74	22.23	43.97	54.00	-10.03	AVG	100	318

1-Emission level (dBuV/m) = Raw Value (dBuV) + Correction Factor (dB/m).

2-Correction Factor (dB/m) = Antenna Factor (dB/m) + Cable Factor (dB).

3-The other emission levels were very low against the limit.

4-Margin value = Emission level – Limit value.

5- " \* ": Fundamental frequency.

Test Channel	TX Channel 48	Detector Function	Peak (PK) Average (AV)
Frequency Range	1GHz ~ 40GHz		

Antennal Polarity & Test Distance: Horizontal at 3 m									
No.	Frequency (MHz)	Reading (dBuV)	Factor (dB)	Emission Level (dBuV/m)	Limit (dBuV/m)	Margin (dB)	Detector	Antenna Height (cm)	Table Angle (Degree)
1 *	5240.000	106.71	7.97	114.68			peak	212	277
2 *	5240.000	70.82	7.97	78.79			AVG	212	277
3	10480.000	40.49	18.26	58.75	74.00	-15.25	peak	199	253
4	10480.000	24.85	18.26	43.11	54.00	-10.89	AVG	199	253
5	15720.000	35.94	22.19	58.13	74.00	-15.87	peak	100	360
6	15720.000	21.72	22.19	43.91	54.00	-10.09	AVG	100	360
Antennal Polarity & Test Distance: Vertical at 3 m									
No.	Frequency (MHz)	Reading (dBuV)	Factor (dB)	Emission Level (dBuV/m)	Limit (dBuV/m)	Margin (dB)	Detector	Antenna Height (cm)	Table Angle (Degree)
1 *	5240.000	92.33	7.97	100.30			peak	100	241
2 *	5240.000	66.24	7.97	74.21			AVG	100	241
3	10480.000	38.37	18.26	56.63	74.00	-17.37	peak	100	142
4	10480.000	22.56	18.26	40.82	54.00	-13.18	AVG	100	142
5	15720.000	36.01	22.19	58.20	74.00	-15.80	peak	100	0
6	15720.000	21.68	22.19	43.87	54.00	-10.13	AVG	100	0

1-Emission level (dBuV/m) = Raw Value (dBuV) + Correction Factor (dB/m).

2-Correction Factor (dB/m) = Antenna Factor (dB/m) + Cable Factor (dB).

3-The other emission levels were very low against the limit.

4-Margin value = Emission level – Limit value.

5- " \* ": Fundamental frequency.

Test Channel	TX Channel 52	Detector Function	Peak (PK) Average (AV)
Frequency Range	1GHz ~ 40GHz		

Antennal Polarity & Test Distance: Horizontal at 3 m									
No.	Frequency (MHz)	Reading (dBuV)	Factor (dB)	Emission Level (dBuV/m)	Limit (dBuV/m)	Margin (dB)	Detector	Antenna Height (cm)	Table Angle (Degree)
1 *	5260.000	107.86	7.41	115.27			peak	233	265
2 *	5260.000	72.00	7.41	79.41			AVG	233	265
3	10520.000	41.98	18.36	60.34	74.00	-13.66	peak	165	249
4	10520.000	27.27	18.36	45.63	54.00	-8.37	AVG	165	249
5	15780.000	36.57	22.17	58.74	74.00	-15.26	peak	100	0
6	15780.000	22.31	22.17	44.48	54.00	-9.52	AVG	100	0
Antennal Polarity & Test Distance: Vertical at 3 m									
No.	Frequency (MHz)	Reading (dBuV)	Factor (dB)	Emission Level (dBuV/m)	Limit (dBuV/m)	Margin (dB)	Detector	Antenna Height (cm)	Table Angle (Degree)
1 *	5260.000	103.13	7.41	110.54			peak	100	257
2 *	5260.000	67.02	7.41	74.43			AVG	100	257
3	10520.000	39.04	18.36	57.40	74.00	-16.60	peak	100	195
4	10520.000	24.63	18.36	42.99	54.00	-11.01	AVG	100	195
5	15780.000	36.86	22.17	59.03	74.00	-14.97	peak	100	360
6	15780.000	22.35	22.17	44.52	54.00	-9.48	AVG	100	360

- 1-Emission level (dBuV/m) = Raw Value (dBuV) + Correction Factor (dB/m).
- 2-Correction Factor (dB/m) = Antenna Factor (dB/m) + Cable Factor (dB).
- 3-The other emission levels were very low against the limit.
- 4-Margin value = Emission level – Limit value.
- 5- " \* ": Fundamental frequency.

Test Channel	TX Channel 60	Detector Function	Peak (PK) Average (AV)
Frequency Range	1GHz ~ 40GHz		

Antennal Polarity & Test Distance: Horizontal at 3 m									
No.	Frequency (MHz)	Reading (dBuV)	Factor (dB)	Emission Level (dBuV/m)	Limit (dBuV/m)	Margin (dB)	Detector	Antenna Height (cm)	Table Angle (Degree)
1 *	5300.000	106.75	6.26	113.01			peak	223	269
2 *	5300.000	70.19	6.26	76.45			AVG	223	269
3	5350.000	52.37	6.34	58.71	74.00	-15.29	peak	223	269
4	5350.000	39.08	6.34	45.42	54.00	-8.58	AVG	223	269
5	10600.000	39.67	18.52	58.19	74.00	-15.81	peak	100	237
6	10600.000	24.86	18.52	43.38	54.00	-10.62	AVG	100	237
7	15900.000	35.16	22.13	57.29	74.00	-16.71	peak	100	0
8	15900.000	22.11	22.13	44.24	54.00	-9.76	AVG	100	0
Antennal Polarity & Test Distance: Vertical at 3 m									
No.	Frequency (MHz)	Reading (dBuV)	Factor (dB)	Emission Level (dBuV/m)	Limit (dBuV/m)	Margin (dB)	Detector	Antenna Height (cm)	Table Angle (Degree)
1 *	5300.000	93.49	6.26	99.75			peak	136	274
2 *	5300.000	66.95	6.26	73.21			AVG	136	274
3	5350.000	50.30	6.34	56.64	74.00	-17.36	peak	136	274
4	5350.000	36.19	6.34	42.53	54.00	-11.47	AVG	136	274
5	10600.000	37.89	18.52	56.41	74.00	-17.59	peak	100	173
6	10600.000	23.44	18.52	41.96	54.00	-12.04	AVG	100	173
7	15900.000	35.49	22.13	57.62	74.00	-16.38	peak	100	360
8	15900.000	22.13	22.13	44.26	54.00	-9.74	AVG	100	360

1-Emission level (dBuV/m) = Raw Value (dBuV) + Correction Factor (dB/m).

2-Correction Factor (dB/m) = Antenna Factor (dB/m) + Cable Factor (dB).

3-The other emission levels were very low against the limit.

4-Margin value = Emission level – Limit value.

5- " \* ": Fundamental frequency.

Test Channel	TX Channel 64	Detector Function	Peak (PK) Average (AV)
Frequency Range	1GHz ~ 40GHz		

Antennal Polarity & Test Distance: Horizontal at 3 m									
No.	Frequency (MHz)	Reading (dBuV)	Factor (dB)	Emission Level (dBuV/m)	Limit (dBuV/m)	Margin (dB)	Detector	Antenna Height (cm)	Table Angle (Degree)
1 *	5320.000	107.15	6.29	113.44			peak	190	263
2 *	5320.000	71.23	6.29	77.52			AVG	190	263
3	5350.000	55.32	6.34	61.66	74.00	-12.34	peak	190	263
4	5350.000	40.17	6.34	46.51	54.00	-7.49	AVG	190	263
5	10640.000	39.60	18.60	58.20	74.00	-15.80	peak	165	211
6	10640.000	24.53	18.60	43.13	54.00	-10.87	AVG	165	211
7	15960.000	36.25	22.11	58.36	74.00	-15.64	peak	100	0
8	15960.000	21.86	22.11	43.97	54.00	-10.03	AVG	100	0
Antennal Polarity & Test Distance: Vertical at 3 m									
No.	Frequency (MHz)	Reading (dBuV)	Factor (dB)	Emission Level (dBuV/m)	Limit (dBuV/m)	Margin (dB)	Detector	Antenna Height (cm)	Table Angle (Degree)
1 *	5320.000	93.44	6.29	99.73			peak	100	281
2 *	5320.000	68.67	6.29	74.96			AVG	100	281
3	5350.000	51.43	6.34	57.77	74.00	-16.23	peak	100	281
4	5350.000	35.96	6.34	42.30	54.00	-11.70	AVG	100	281
5	10640.000	37.74	18.60	56.34	74.00	-17.66	peak	100	132
6	10640.000	22.96	18.60	41.56	54.00	-12.44	AVG	100	132
7	15960.000	36.16	22.11	58.27	74.00	-15.73	peak	100	360
8	15960.000	21.97	22.11	44.08	54.00	-9.92	AVG	100	360

1-Emission level (dBuV/m) = Raw Value (dBuV) + Correction Factor (dB/m).

2-Correction Factor (dB/m) = Antenna Factor (dB/m) + Cable Factor (dB).

3-The other emission levels were very low against the limit.

4-Margin value = Emission level – Limit value.

5- " \* ": Fundamental frequency.



Test Channel	TX Channel 100	Detector Function	Peak (PK) Average (AV)
Frequency Range	1GHz ~ 40GHz		

Antennal Polarity & Test Distance: Horizontal at 3 m									
No.	Frequency (MHz)	Reading (dBuV)	Factor (dB)	Emission Level (dBuV/m)	Limit (dBuV/m)	Margin (dB)	Detector	Antenna Height (cm)	Table Angle (Degree)
1 #	5470.000	58.04	6.50	64.54	68.20	-3.66	peak	210	267
2 *	5500.000	109.00	6.54	115.54			peak	210	267
3 *	5500.000	71.69	6.54	78.23			AVG	210	267
4	11000.000	39.55	19.32	58.87	74.00	-15.13	peak	100	252
5	11000.000	24.40	19.32	43.72	54.00	-10.28	AVG	100	252
6	16500.000	36.77	23.34	60.11	74.00	-13.89	peak	100	0
7	16500.000	23.59	23.34	46.93	54.00	-7.07	AVG	100	0
Antennal Polarity & Test Distance: Vertical at 3 m									
No.	Frequency (MHz)	Reading (dBuV)	Factor (dB)	Emission Level (dBuV/m)	Limit (dBuV/m)	Margin (dB)	Detector	Antenna Height (cm)	Table Angle (Degree)
1 #	5470.000	54.84	6.50	61.34	68.20	-6.86	peak	179	272
2 *	5500.000	105.27	6.54	111.81			peak	179	272
3 *	5500.000	68.09	6.54	74.63			AVG	179	272
4	11000.000	36.65	19.32	55.97	74.00	-18.03	peak	100	159
5	11000.000	20.88	19.32	40.20	54.00	-13.80	AVG	100	159
6	16500.000	36.73	23.34	60.07	74.00	-13.93	peak	100	360
7	16500.000	23.52	23.34	46.86	54.00	-7.14	AVG	100	360

1-Emission level (dBuV/m) = Raw Value (dBuV) + Correction Factor (dB/m).

2-Correction Factor (dB/m) = Antenna Factor (dB/m) + Cable Factor (dB).

3-The other emission levels were very low against the limit.

4-Margin value = Emission level – Limit value.

5- " \* ": Fundamental frequency.

6- " # ": The radiated frequency is out of the restricted band

Test Channel	TX Channel 120	Detector Function	Peak (PK) Average (AV)
Frequency Range	1GHz ~ 40GHz		

Antennal Polarity & Test Distance: Horizontal at 3 m									
No.	Frequency (MHz)	Reading (dBuV)	Factor (dB)	Emission Level (dBuV/m)	Limit (dBuV/m)	Margin (dB)	Detector	Antenna Height (cm)	Table Angle (Degree)
1 #	5470.000	53.75	6.50	60.25	68.20	-7.95	peak	238	262
2 *	5600.000	107.85	6.72	114.57			peak	238	262
3 *	5600.000	71.42	6.72	78.14			AVG	238	262
4	11200.000	39.22	19.51	58.73	74.00	-15.27	peak	100	263
5	11200.000	24.78	19.51	44.29	54.00	-9.71	AVG	100	263
6	16800.000	36.04	24.44	60.48	74.00	-13.52	peak	100	0
7	16800.000	22.88	24.44	47.32	54.00	-6.68	AVG	100	0
Antennal Polarity & Test Distance: Vertical at 3 m									
No.	Frequency (MHz)	Reading (dBuV)	Factor (dB)	Emission Level (dBuV/m)	Limit (dBuV/m)	Margin (dB)	Detector	Antenna Height (cm)	Table Angle (Degree)
1 #	5470.000	53.81	6.50	60.31	68.20	-7.89	peak	100	237
2 *	5600.000	93.54	6.72	100.26			peak	100	237
3 *	5600.000	67.56	6.72	74.28			AVG	100	237
4	11200.000	36.70	19.51	56.21	74.00	-17.79	peak	100	145
5	11200.000	22.36	19.51	41.87	54.00	-12.13	AVG	100	145
6	16800.000	35.91	24.44	60.35	74.00	-13.65	peak	100	360
7	16800.000	22.82	24.44	47.26	54.00	-6.74	AVG	100	360

1-Emission level (dBuV/m) = Raw Value (dBuV) + Correction Factor (dB/m).

2-Correction Factor (dB/m) = Antenna Factor (dB/m) + Cable Factor (dB).

3-The other emission levels were very low against the limit.

4-Margin value = Emission level – Limit value.

5- " \* ": Fundamental frequency.

6- " # ": The radiated frequency is out of the restricted band

Test Channel	TX Channel 140	Detector Function	Peak (PK) Average (AV)
Frequency Range	1GHz ~ 40GHz		

Antennal Polarity & Test Distance: Horizontal at 3 m									
No.	Frequency (MHz)	Reading (dBuV)	Factor (dB)	Emission Level (dBuV/m)	Limit (dBuV/m)	Margin (dB)	Detector	Antenna Height (cm)	Table Angle (Degree)
1 *	5700.000	107.72	6.92	114.64			peak	208	229
2 *	5700.000	71.09	6.92	78.01			AVG	208	229
3 #	5725.000	58.69	6.96	65.65	68.20	-2.55	peak	208	229
4	11400.000	37.01	19.68	56.69	74.00	-17.31	peak	100	137
5	11400.000	22.73	19.68	42.41	54.00	-11.59	AVG	100	137
6	17100.000	36.65	25.59	62.24	74.00	-11.76	peak	100	360
7	17100.000	21.92	25.59	47.51	54.00	-6.49	AVG	100	360
Antennal Polarity & Test Distance: Vertical at 3 m									
No.	Frequency (MHz)	Reading (dBuV)	Factor (dB)	Emission Level (dBuV/m)	Limit (dBuV/m)	Margin (dB)	Detector	Antenna Height (cm)	Table Angle (Degree)
1 *	5700.000	92.56	6.92	99.48			peak	173	287
2 *	5700.000	67.44	6.92	74.36			AVG	173	287
3 #	5725.000	54.78	6.96	61.74	68.20	-6.46	peak	173	287
4	11400.000	36.13	19.68	55.81	74.00	-18.19	peak	100	211
5	11400.000	21.37	19.68	41.05	54.00	-12.95	AVG	100	211
6	17100.000	36.78	25.59	62.37	74.00	-11.63	peak	100	0
7	17100.000	21.97	25.59	47.56	54.00	-6.44	AVG	100	0

1-Emission level (dBuV/m) = Raw Value (dBuV) + Correction Factor (dB/m).

2-Correction Factor (dB/m) = Antenna Factor (dB/m) + Cable Factor (dB).

3-The other emission levels were very low against the limit.

4-Margin value = Emission level – Limit value.

5- " \* ": Fundamental frequency.

6- " # ": The radiated frequency is out of the restricted band

Test Channel	TX Channel 149	Detector Function	Peak (PK) Average (AV)
Frequency Range	1GHz ~ 40GHz		

Antennal Polarity & Test Distance: Horizontal at 3 m									
No.	Frequency (MHz)	Reading (dBuV)	Factor (dB)	Emission Level (dBuV/m)	Limit (dBuV/m)	Margin (dB)	Detector	Antenna Height (cm)	Table Angle (Degree)
1#	5650.000	46.83	6.82	53.65	68.2	-14.55	peak	208	228
2#	5725.000	68.76	6.96	75.72	122.20	-46.48	peak	208	228
3 *	5745.000	109.51	6.99	116.50			peak	208	228
4 *	5745.000	74.40	6.99	81.39			AVG	208	228
5	11490.000	40.07	19.77	59.84	74.00	-14.16	peak	100	212
6	11490.000	25.08	19.77	44.85	54.00	-9.15	AVG	100	212
7	17235.000	35.32	26.17	61.49	74.00	-12.51	peak	100	190
8	17235.000	20.88	26.17	47.05	54.00	-6.95	AVG	100	190
Antennal Polarity & Test Distance: Vertical at 3 m									
No.	Frequency (MHz)	Reading (dBuV)	Factor (dB)	Emission Level (dBuV/m)	Limit (dBuV/m)	Margin (dB)	Detector	Antenna Height (cm)	Table Angle (Degree)
1 #	5650.000	42.75	6.82	49.57	68.2	-18.63	peak	142	241
2	5725.000	65.00	6.96	71.96	122.20	-50.24	peak	142	241
3 *	5745.000	104.74	6.99	111.73			peak	142	241
4 *	5745.000	69.60	6.99	76.59			AVG	142	241
5	11490.000	36.85	19.77	56.62	74.00	-17.38	peak	100	173
6	11490.000	22.02	19.77	41.79	54.00	-12.21	AVG	100	173
7	17235.000	35.20	26.17	61.37	74.00	-12.63	peak	100	340
8	17235.000	20.83	26.17	47.00	54.00	-7.00	AVG	100	340

1-Emission level (dBuV/m) = Raw Value (dBuV) + Correction Factor (dB/m).

2-Correction Factor (dB/m) = Antenna Factor (dB/m) + Cable Factor (dB).

3-The other emission levels were very low against the limit.

4-Margin value = Emission level – Limit value.

5- " \* ": Fundamental frequency.

6- " # ": The radiated frequency is out of the restricted band

Test Channel	TX Channel 157	Detector Function	Peak (PK) Average (AV)
Frequency Range	1GHz ~ 40GHz		

Antennal Polarity & Test Distance: Horizontal at 3 m									
No.	Frequency (MHz)	Reading (dBuV)	Factor (dB)	Emission Level (dBuV/m)	Limit (dBuV/m)	Margin (dB)	Detector	Antenna Height (cm)	Table Angle (Degree)
1 #	5725.000	54.52	6.96	61.48	122.20	-60.72	peak	204	232
2 *	5785.000	110.35	7.07	117.42			peak	204	232
3 *	5785.000	74.83	7.07	81.90			AVG	204	232
4	5850.000	54.07	7.20	61.27	122.20	-60.93	peak	204	232
5	11570.000	41.50	19.75	61.25	74.00	-12.75	peak	167	235
6	11570.000	25.96	19.75	45.71	54.00	-8.29	AVG	167	235
7	17355.000	33.80	26.68	60.48	74.00	-13.52	peak	100	0
8	17355.000	20.27	26.68	46.95	54.00	-7.05	AVG	100	0
Antennal Polarity & Test Distance: Vertical at 3 m									
No.	Frequency (MHz)	Reading (dBuV)	Factor (dB)	Emission Level (dBuV/m)	Limit (dBuV/m)	Margin (dB)	Detector	Antenna Height (cm)	Table Angle (Degree)
1 #	5725.000	54.93	6.96	61.89	122.20	-60.31	peak	117	254
2 *	5785.000	106.75	7.07	113.82			peak	117	254
3 *	5785.000	70.86	7.07	77.93			AVG	117	254
4	5850.000	55.17	7.20	62.37	122.20	-59.83	peak	117	254
5	11570.000	37.65	19.75	57.40	74.00	-16.60	peak	100	186
6	11570.000	22.09	19.75	41.84	54.00	-12.16	AVG	100	186
7	17355.000	34.60	26.68	61.28	74.00	-12.72	peak	100	360
8	17355.000	20.34	26.68	47.02	54.00	-6.98	AVG	100	360

1-Emission level (dBuV/m) = Raw Value (dBuV) + Correction Factor (dB/m).

2-Correction Factor (dB/m) = Antenna Factor (dB/m) + Cable Factor (dB).

3-The other emission levels were very low against the limit.

4-Margin value = Emission level – Limit value.

5- " \* ": Fundamental frequency.

6- " # ": The radiated frequency is out of the restricted band

Test Channel	TX Channel 165	Detector Function	Peak (PK) Average (AV)
Frequency Range	1GHz ~ 40GHz		

Antennal Polarity & Test Distance: Horizontal at 3 m									
No.	Frequency (MHz)	Reading (dBuV)	Factor (dB)	Emission Level (dBuV/m)	Limit (dBuV/m)	Margin (dB)	Detector	Antenna Height (cm)	Table Angle (Degree)
1 *	5825.000	107.09	7.15	114.24			peak	218	227
2 *	5825.000	73.08	7.15	80.23			AVG	218	227
3	5850.000	60.83	7.20	68.03	122.20	-54.17	peak	218	227
4	11650.000	41.56	19.72	61.28	74.00	-12.72	peak	186	231
5	11650.000	26.65	19.72	46.37	54.00	-7.63	AVG	186	231
6	17475.000	34.60	27.19	61.79	74.00	-12.21	peak	100	0
7	17475.000	19.92	27.19	47.11	54.00	-6.89	AVG	100	0
Antennal Polarity & Test Distance: Vertical at 3 m									
No.	Frequency (MHz)	Reading (dBuV)	Factor (dB)	Emission Level (dBuV/m)	Limit (dBuV/m)	Margin (dB)	Detector	Antenna Height (cm)	Table Angle (Degree)
1 *	5825.000	103.14	7.15	110.29			peak	153	247
2 *	5825.000	68.51	7.15	75.66			AVG	153	247
3	5850.000	58.20	7.20	65.40	122.20	-56.80	peak	153	247
4	11650.000	38.89	19.72	58.61	74.00	-15.39	peak	100	178
5	11650.000	22.63	19.72	42.35	54.00	-11.65	AVG	100	178
6	17475.000	34.25	27.19	61.44	74.00	-12.56	peak	100	360
7	17475.000	19.84	27.19	47.03	54.00	-6.97	AVG	100	360

1-Emission level (dBuV/m) = Raw Value (dBuV) + Correction Factor (dB/m).

2-Correction Factor (dB/m) = Antenna Factor (dB/m) + Cable Factor (dB).

3-The other emission levels were very low against the limit.

4-Margin value = Emission level – Limit value.

5- " \* ": Fundamental frequency.

6- " # ": The radiated frequency is out of the restricted band

802.11n HT40

Test Channel	TX Channel 38	Detector Function	Peak (PK) Average (AV)
Frequency Range	1GHz ~ 40GHz		

Antennal Polarity & Test Distance: Horizontal at 3 m

No.	Frequency (MHz)	Reading (dBuV)	Factor (dB)	Emission Level (dBuV/m)	Limit (dBuV/m)	Margin (dB)	Detector	Antenna Height (cm)	Table Angle (Degree)
1	5150.000	63.99	7.54	71.53	74.00	-2.47	peak	221	270
2	5150.000	40.28	7.54	47.82	54.00	-6.18	AVG	221	270
3 *	5190.000	102.49	8.80	111.29			peak	221	270
4 *	5190.000	60.94	8.80	69.74			AVG	221	270
5	10380.000	40.76	17.93	58.69	74.00	-15.31	peak	100	360
6	10380.000	25.88	17.93	43.81	54.00	-10.19	AVG	100	360
7	15570.000	37.11	22.24	59.35	74.00	-14.65	peak	100	0
8	15570.000	22.93	22.24	45.17	54.00	-8.83	AVG	100	0

Antennal Polarity & Test Distance: Vertical at 3 m

No.	Frequency (MHz)	Reading (dBuV)	Factor (dB)	Emission Level (dBuV/m)	Limit (dBuV/m)	Margin (dB)	Detector	Antenna Height (cm)	Table Angle (Degree)
1	5150.000	59.89	7.54	67.43	74.00	-6.57	peak	100	252
2	5150.000	36.18	7.54	43.72	54.00	-10.28	AVG	100	252
3 *	5190.000	99.54	8.80	108.34			peak	100	252
4 *	5190.000	56.43	8.80	65.23			AVG	100	252
5	10380.000	36.23	17.93	54.16	74.00	-19.84	peak	100	0
6	10380.000	20.37	17.93	38.30	54.00	-15.70	AVG	100	0
7	15570.000	37.17	22.24	59.41	74.00	-14.59	peak	100	360
8	15570.000	23.09	22.24	45.33	54.00	-8.67	AVG	100	360

1-Emission level (dBuV/m) = Raw Value (dBuV) + Correction Factor (dB/m).

2-Correction Factor (dB/m) = Antenna Factor (dB/m) + Cable Factor (dB).

3-The other emission levels were very low against the limit.

4-Margin value = Emission level – Limit value.

5- " \* " : Fundamental frequency.

Test Channel	TX Channel 46	Detector Function	Peak (PK) Average (AV)
Frequency Range	1GHz ~ 40GHz		

Antennal Polarity & Test Distance: Horizontal at 3 m									
No.	Frequency (MHz)	Reading (dBuV)	Factor (dB)	Emission Level (dBuV/m)	Limit (dBuV/m)	Margin (dB)	Detector	Antenna Height (cm)	Table Angle (Degree)
1	5150.000	51.82	7.54	59.36	74.00	-14.64	peak	233	272
2	5150.000	37.74	7.54	45.28	54.00	-8.72	AVG	233	272
3 *	5230.000	102.64	8.26	110.90			peak	233	272
4 *	5230.000	61.11	8.26	69.37			AVG	233	272
5	10460.000	38.81	18.19	57.00	74.00	-17.00	peak	100	193
6	10460.000	21.63	18.19	39.82	54.00	-14.18	AVG	100	193
7	15690.000	36.30	22.20	58.50	74.00	-15.50	peak	100	360
8	15690.000	20.69	22.20	42.89	54.00	-11.11	AVG	100	360
Antennal Polarity & Test Distance: Vertical at 3 m									
No.	Frequency (MHz)	Reading (dBuV)	Factor (dB)	Emission Level (dBuV/m)	Limit (dBuV/m)	Margin (dB)	Detector	Antenna Height (cm)	Table Angle (Degree)
1	5150.000	51.17	7.54	58.71	74.00	-15.29	peak	147	265
2	5150.000	36.78	7.54	44.32	54.00	-9.68	AVG	147	265
3 *	5230.000	98.12	8.26	106.38			peak	147	265
4 *	5230.000	57.58	8.26	65.84			AVG	147	265
5	10460.000	38.22	18.19	56.41	74.00	-17.59	peak	100	124
6	10460.000	23.05	18.19	41.24	54.00	-12.76	AVG	100	124
7	15690.000	36.01	22.20	58.21	74.00	-15.79	peak	100	0
8	15690.000	20.57	22.20	42.77	54.00	-11.23	AVG	100	0

1-Emission level (dBuV/m) = Raw Value (dBuV) + Correction Factor (dB/m).

2-Correction Factor (dB/m) = Antenna Factor (dB/m) + Cable Factor (dB).

3-The other emission levels were very low against the limit.

4-Margin value = Emission level – Limit value.

5- " \* ": Fundamental frequency.



Test Channel	TX Channel 54	Detector Function	Peak (PK) Average (AV)
Frequency Range	1GHz ~ 40GHz		

Antennal Polarity & Test Distance: Horizontal at 3 m									
No.	Frequency (MHz)	Reading (dBuV)	Factor (dB)	Emission Level (dBuV/m)	Limit (dBuV/m)	Margin (dB)	Detector	Antenna Height (cm)	Table Angle (Degree)
1 *	5270.000	102.41	7.12	109.53			peak	213	275
2 *	5270.000	60.91	7.12	68.03			AVG	213	275
3	5350.000	52.65	6.34	58.99	74.00	-15.01	peak	213	275
4	5350.000	38.88	6.34	45.22	54.00	-8.78	AVG	213	275
5	10540.000	39.37	18.40	57.77	74.00	-16.23	peak	100	228
6	10540.000	24.78	18.40	43.18	54.00	-10.82	AVG	100	228
7	15810.000	36.30	22.16	58.46	74.00	-15.54	peak	100	360
8	15810.000	21.97	22.16	44.13	54.00	-9.87	AVG	100	360
Antennal Polarity & Test Distance: Vertical at 3 m									
No.	Frequency (MHz)	Reading (dBuV)	Factor (dB)	Emission Level (dBuV/m)	Limit (dBuV/m)	Margin (dB)	Detector	Antenna Height (cm)	Table Angle (Degree)
1 *	5270.000	98.35	7.12	105.47			peak	178	244
2 *	5270.000	56.81	7.12	63.93			AVG	178	244
3	5350.000	50.79	6.34	57.13	74.00	-16.87	peak	178	244
4	5350.000	38.33	6.34	44.67	54.00	-9.33	AVG	178	244
5	10540.000	36.42	18.40	54.82	74.00	-19.18	peak	100	113
6	10540.000	22.75	18.40	41.15	54.00	-12.85	AVG	100	113
7	15810.000	36.17	22.16	58.33	74.00	-15.67	peak	100	0
8	15810.000	22.04	22.16	44.20	54.00	-9.80	AVG	100	0

1-Emission level (dBuV/m) = Raw Value (dBuV) + Correction Factor (dB/m).

2-Correction Factor (dB/m) = Antenna Factor (dB/m) + Cable Factor (dB).

3-The other emission levels were very low against the limit.

4-Margin value = Emission level – Limit value.

5- " \* ": Fundamental frequency.

Test Channel	TX Channel 62	Detector Function	Peak (PK) Average (AV)
Frequency Range	1GHz ~ 40GHz		

Antennal Polarity & Test Distance: Horizontal at 3 m									
No.	Frequency (MHz)	Reading (dBuV)	Factor (dB)	Emission Level (dBuV/m)	Limit (dBuV/m)	Margin (dB)	Detector	Antenna Height (cm)	Table Angle (Degree)
1 *	5310.000	104.00	6.28	110.28			peak	230	271
2 *	5310.000	62.19	6.28	68.47			AVG	230	271
3	5350.000	58.46	6.34	64.80	74.00	-9.20	peak	230	271
4	5350.000	39.90	6.34	46.24	54.00	-7.76	AVG	230	271
5	10620.000	39.08	18.56	57.64	74.00	-16.36	peak	100	203
6	10620.000	24.00	18.56	42.56	54.00	-11.44	AVG	100	203
7	15930.000	36.73	22.12	58.85	74.00	-15.15	peak	100	0
8	15930.000	22.00	22.12	44.12	54.00	-9.88	AVG	100	0
Antennal Polarity & Test Distance: Vertical at 3 m									
No.	Frequency (MHz)	Reading (dBuV)	Factor (dB)	Emission Level (dBuV/m)	Limit (dBuV/m)	Margin (dB)	Detector	Antenna Height (cm)	Table Angle (Degree)
1 *	5310.000	100.36	6.28	106.64			peak	114	228
2 *	5310.000	58.43	6.28	64.71			AVG	114	228
3	5350.000	55.89	6.34	62.23	74.00	-11.77	peak	114	228
4	5350.000	37.55	6.34	43.89	54.00	-10.11	AVG	114	228
5	10620.000	36.74	18.56	55.30	74.00	-18.70	peak	100	158
6	10620.000	23.15	18.56	41.71	54.00	-12.29	AVG	100	158
7	15930.000	36.32	22.12	58.44	74.00	-15.56	peak	100	360
8	15930.000	21.84	22.12	43.96	54.00	-10.04	AVG	100	360

1-Emission level (dBuV/m) = Raw Value (dBuV) + Correction Factor (dB/m).

2-Correction Factor (dB/m) = Antenna Factor (dB/m) + Cable Factor (dB).

3-The other emission levels were very low against the limit.

4-Margin value = Emission level – Limit value.

5- " \* ": Fundamental frequency.

Test Channel	TX Channel 102	Detector Function	Peak (PK) Average (AV)
Frequency Range	1GHz ~ 40GHz		

Antennal Polarity & Test Distance: Horizontal at 3 m									
No.	Frequency (MHz)	Reading (dBuV)	Factor (dB)	Emission Level (dBuV/m)	Limit (dBuV/m)	Margin (dB)	Detector	Antenna Height (cm)	Table Angle (Degree)
1	5460.000	50.91	6.34	57.25	74.00	-16.75	peak	225	260
2	5460.000	42.49	6.34	48.83	74.00	-25.17	AVG	225	260
3#	5470.000	58.71	6.50	65.21	68.20	-2.99	peak	217	266
4 *	5510.000	104.70	6.56	111.26			peak	217	266
5 *	5510.000	62.22	6.56	68.78			AVG	217	266
6	11020.000	38.67	19.34	58.01	74.00	-15.99	peak	100	232
7	11020.000	24.49	19.34	43.83	54.00	-10.17	AVG	100	232
8	16530.000	37.83	23.45	61.28	74.00	-12.72	peak	100	15
9	16530.000	22.35	23.45	45.80	54.00	-8.20	AVG	100	15
Antennal Polarity & Test Distance: Vertical at 3 m									
No.	Frequency (MHz)	Reading (dBuV)	Factor (dB)	Emission Level (dBuV/m)	Limit (dBuV/m)	Margin (dB)	Detector	Antenna Height (cm)	Table Angle (Degree)
1	5460.000	49.31	6.34	55.65	74.00	-18.35	peak	135	254
2	5460.000	40.56	6.34	46.9	74.00	-27.1	AVG	135	254
3#	5470.000	55.97	6.50	62.47	68.20	-5.73	peak	135	254
4 *	5510.000	102.17	6.56	108.73			peak	135	254
5 *	5510.000	58.90	6.56	65.46			AVG	135	254
6	11020.000	37.44	19.34	56.78	74.00	-17.22	peak	100	211
7	11020.000	22.15	19.34	41.49	54.00	-12.51	AVG	100	211
8	16530.000	37.69	23.45	61.14	74.00	-12.86	peak	100	350
9	16530.000	22.30	23.45	45.75	54.00	-8.25	AVG	100	350

1-Emission level (dBuV/m) = Raw Value (dBuV) + Correction Factor (dB/m).

2-Correction Factor (dB/m) = Antenna Factor (dB/m) + Cable Factor (dB).

3-The other emission levels were very low against the limit.

4-Margin value = Emission level – Limit value.

5- " \* ": Fundamental frequency.

6- " # ": The radiated frequency is out of the restricted band

Test Channel	TX Channel 118	Detector Function	Peak (PK) Average (AV)
Frequency Range	1GHz ~ 40GHz		

Antennal Polarity & Test Distance: Horizontal at 3 m									
No.	Frequency (MHz)	Reading (dBuV)	Factor (dB)	Emission Level (dBuV/m)	Limit (dBuV/m)	Margin (dB)	Detector	Antenna Height (cm)	Table Angle (Degree)
1 #	5470.000	54.44	6.50	60.94	68.20	-7.26	peak	217	267
2 *	5590.000	103.66	6.70	110.36			peak	217	267
3 *	5590.000	61.90	6.70	68.60			AVG	217	267
4	11180.000	39.06	19.48	58.54	74.00	-15.46	peak	178	253
5	11180.000	25.31	19.48	44.79	54.00	-9.21	AVG	178	253
6	16770.000	37.18	24.33	61.51	74.00	-12.49	peak	100	0
7	16770.000	22.71	24.33	47.04	54.00	-6.96	AVG	100	0
Antennal Polarity & Test Distance: Vertical at 3 m									
No.	Frequency (MHz)	Reading (dBuV)	Factor (dB)	Emission Level (dBuV/m)	Limit (dBuV/m)	Margin (dB)	Detector	Antenna Height (cm)	Table Angle (Degree)
1 #	5470.000	54.54	6.50	61.04	68.20	-7.16	peak	168	274
2 *	5590.000	99.08	6.70	105.78			peak	168	274
3 *	5590.000	57.62	6.70	64.32			AVG	168	274
4	11180.000	35.92	19.48	55.40	74.00	-18.60	peak	100	177
5	11180.000	21.81	19.48	41.29	54.00	-12.71	AVG	100	177
6	16770.000	36.87	24.33	61.20	74.00	-12.80	peak	100	360
7	16770.000	22.80	24.33	47.13	54.00	-6.87	AVG	100	360

1-Emission level (dBuV/m) = Raw Value (dBuV) + Correction Factor (dB/m).

2-Correction Factor (dB/m) = Antenna Factor (dB/m) + Cable Factor (dB).

3-The other emission levels were very low against the limit.

4-Margin value = Emission level – Limit value.

5- " \* ": Fundamental frequency.

6- " # ": The radiated frequency is out of the restricted band

Test Channel	TX Channel 134	Detector Function	Peak (PK) Average (AV)
Frequency Range	1GHz ~ 40GHz		

Antennal Polarity & Test Distance: Horizontal at 3 m									
No.	Frequency (MHz)	Reading (dBuV)	Factor (dB)	Emission Level (dBuV/m)	Limit (dBuV/m)	Margin (dB)	Detector	Antenna Height (cm)	Table Angle (Degree)
1 *	5670.000	105.04	6.85	111.89			peak	210	230
2 *	5670.000	62.25	6.85	69.10			AVG	210	230
3 #	5725.000	57.15	6.96	64.11	68.20	-4.09	peak	210	230
4	11340.000	41.39	19.63	61.02	74.00	-12.98	peak	164	248
5	11340.000	26.86	19.63	46.49	54.00	-7.51	AVG	164	248
6	17010.000	35.37	25.21	60.58	74.00	-13.42	peak	100	0
7	17010.000	20.73	25.21	45.94	54.00	-8.06	AVG	100	0
Antennal Polarity & Test Distance: Vertical at 3 m									
No.	Frequency (MHz)	Reading (dBuV)	Factor (dB)	Emission Level (dBuV/m)	Limit (dBuV/m)	Margin (dB)	Detector	Antenna Height (cm)	Table Angle (Degree)
1 *	5670.000	100.77	6.85	107.62			peak	187	271
2 *	5670.000	58.63	6.85	65.48			AVG	187	271
3 #	5725.000	54.97	6.96	61.93	68.20	-6.27	peak	187	271
4	11340.000	37.69	19.63	57.32	74.00	-16.68	peak	100	185
5	11340.000	22.42	19.63	42.05	54.00	-11.95	AVG	100	185
6	17010.000	35.30	25.21	60.51	74.00	-13.49	peak	100	360
7	17010.000	20.85	25.21	46.06	54.00	-7.94	AVG	100	360

1-Emission level (dBuV/m) = Raw Value (dBuV) + Correction Factor (dB/m).

2-Correction Factor (dB/m) = Antenna Factor (dB/m) + Cable Factor (dB).

3-The other emission levels were very low against the limit.

4-Margin value = Emission level – Limit value.

5- " \* ": Fundamental frequency.

6- " # ": The radiated frequency is out of the restricted band

Test Channel	TX Channel 151	Detector Function	Peak (PK) Average (AV)
Frequency Range	1GHz ~ 40GHz		

Antennal Polarity & Test Distance: Horizontal at 3 m									
No.	Frequency (MHz)	Reading (dBuV)	Factor (dB)	Emission Level (dBuV/m)	Limit (dBuV/m)	Margin (dB)	Detector	Antenna Height (cm)	Table Angle (Degree)
1 #	5719.210	72.65	6.95	79.60	110.58	-30.98	peak	196	317
2 *	5755.000	104.74	7.01	111.75			peak	196	317
3 *	5755.000	64.99	7.01	72.00			AVG	196	317
4	11510.000	39.66	19.78	59.44	74.00	-14.56	peak	100	278
5	11510.000	26.00	19.78	45.78	54.00	-8.22	AVG	100	278
6	17265.000	35.02	26.30	61.32	74.00	-12.68	peak	100	310
7	17265.000	20.88	26.30	47.18	54.00	-6.82	AVG	100	310
Antennal Polarity & Test Distance: Vertical at 3 m									
No.	Frequency (MHz)	Reading (dBuV)	Factor (dB)	Emission Level (dBuV/m)	Limit (dBuV/m)	Margin (dB)	Detector	Antenna Height (cm)	Table Angle (Degree)
1 #	5719.210	70.30	6.95	77.25	110.58	-33.33	peak	153	286
2 *	5755.000	100.25	7.01	107.26			peak	153	286
3 *	5755.000	61.30	7.01	68.31			AVG	153	286
4	11510.000	36.69	19.78	56.47	74.00	-17.53	peak	100	244
5	11510.000	22.35	19.78	42.13	54.00	-11.87	AVG	100	244
6	17265.000	34.85	26.30	61.15	74.00	-12.85	peak	100	325
7	17265.000	20.83	26.30	47.13	54.00	-6.87	AVG	100	325

1-Emission level (dBuV/m) = Raw Value (dBuV) + Correction Factor (dB/m).

2-Correction Factor (dB/m) = Antenna Factor (dB/m) + Cable Factor (dB).

3-The other emission levels were very low against the limit.

4-Margin value = Emission level – Limit value.

5- " \* ": Fundamental frequency.

6- " # ": The radiated frequency is out of the restricted band

Test Channel	TX Channel 159	Detector Function	Peak (PK) Average (AV)
Frequency Range	1GHz ~ 40GHz		

Antennal Polarity & Test Distance: Horizontal at 3 m									
No.	Frequency (MHz)	Reading (dBuV)	Factor (dB)	Emission Level (dBuV/m)	Limit (dBuV/m)	Margin (dB)	Detector	Antenna Height (cm)	Table Angle (Degree)
1 *	5795.000	104.14	7.09	111.23			peak	200	318
2 *	5795.000	65.29	7.09	72.38			AVG	200	318
3	5850.000	61.08	7.20	68.28	122.20	-53.92	peak	200	318
4	11590.000	41.00	19.74	60.74	74.00	-13.26	peak	188	246
5	11590.000	26.49	19.74	46.23	54.00	-7.77	AVG	188	246
6	17385.000	34.40	26.82	61.22	74.00	-12.78	peak	100	105
7	17385.000	19.54	26.82	46.36	54.00	-7.64	AVG	100	105
Antennal Polarity & Test Distance: Vertical at 3 m									
No.	Frequency (MHz)	Reading (dBuV)	Factor (dB)	Emission Level (dBuV/m)	Limit (dBuV/m)	Margin (dB)	Detector	Antenna Height (cm)	Table Angle (Degree)
1 *	5795.000	100.37	7.09	107.46			peak	100	285
2 *	5795.000	62.22	7.09	69.31			AVG	100	285
3	5850.000	58.64	7.20	65.84	122.20	-56.36	peak	100	285
4	11590.000	37.75	19.74	57.49	74.00	-16.51	peak	100	164
5	11590.000	22.77	19.74	42.51	54.00	-11.49	AVG	100	164
6	17385.000	34.32	26.82	61.14	74.00	-12.86	peak	100	335
7	17385.000	19.43	26.82	46.25	54.00	-7.75	AVG	100	335

1-Emission level (dBuV/m) = Raw Value (dBuV) + Correction Factor (dB/m).

2-Correction Factor (dB/m) = Antenna Factor (dB/m) + Cable Factor (dB).

3-The other emission levels were very low against the limit.

4-Margin value = Emission level – Limit value.

5- " \* ": Fundamental frequency.

6- " # ": The radiated frequency is out of the restricted band

**802.11ac VHT80**

Test Channel	TX Channel 42	Detector Function	Peak (PK) Average (AV)
Frequency Range	1GHz ~ 40GHz		

Antennal Polarity & Test Distance: Horizontal at 3 m									
No.	Frequency (MHz)	Reading (dBuV)	Factor (dB)	Emission Level (dBuV/m)	Limit (dBuV/m)	Margin (dB)	Detector	Antenna Height (cm)	Table Angle (Degree)
1	5150.000	59.74	7.54	67.28	74.00	-6.72	peak	233	272
2	5150.000	39.94	7.54	47.48	54.00	-6.52	AVG	233	272
3 *	5210.000	98.60	8.84	107.44			peak	233	272
4 *	5210.000	53.30	8.84	62.14			AVG	233	272
5	10420.000	41.31	18.06	59.37	74.00	-14.63	peak	100	195
6	10420.000	26.09	18.06	44.15	54.00	-9.85	AVG	100	195
7	15630.000	35.71	22.21	57.92	74.00	-16.08	peak	100	72
8	15630.000	21.73	22.21	43.94	54.00	-10.06	AVG	100	72
Antennal Polarity & Test Distance: Vertical at 3 m									
No.	Frequency (MHz)	Reading (dBuV)	Factor (dB)	Emission Level (dBuV/m)	Limit (dBuV/m)	Margin (dB)	Detector	Antenna Height (cm)	Table Angle (Degree)
1	5150.000	56.64	7.54	64.18	74.00	-9.82	peak	174	263
2	5150.000	36.18	7.54	43.72	54.00	-10.28	AVG	174	263
3 *	5210.000	94.37	8.84	103.21			peak	174	263
4 *	5210.000	51.00	8.84	59.84			AVG	174	263
5	10420.000	38.28	18.06	56.34	74.00	-17.66	peak	100	227
6	10420.000	23.11	18.06	41.17	54.00	-12.83	AVG	100	227
7	15630.000	37.62	22.21	59.83	74.00	-14.17	peak	100	293
8	15630.000	21.68	22.21	43.89	54.00	-10.11	AVG	100	293

1-Emission level (dBuV/m) = Raw Value (dBuV) + Correction Factor (dB/m).

2-Correction Factor (dB/m) = Antenna Factor (dB/m) + Cable Factor (dB).

3-The other emission levels were very low against the limit.

4-Margin value = Emission level – Limit value.

5- " \* ": Fundamental frequency.



Test Channel	TX Channel 52	Detector Function	Peak (PK) Average (AV)
Frequency Range	1GHz ~ 40GHz		

Antennal Polarity & Test Distance: Horizontal at 3 m									
No.	Frequency (MHz)	Reading (dBuV)	Factor (dB)	Emission Level (dBuV/m)	Limit (dBuV/m)	Margin (dB)	Detector	Antenna Height (cm)	Table Angle (Degree)
1 *	5290.000	99.75	6.54	106.29			peak	235	271
2 *	5290.000	54.27	6.54	60.81			AVG	235	271
3	5350.000	61.73	6.34	68.07	74.00	-5.93	peak	235	271
4	5350.000	40.94	6.34	47.28	54.00	-6.72	AVG	235	271
5	10580.000	41.56	18.48	60.04	74.00	-13.96	peak	100	277
6	10580.000	27.12	18.48	45.60	54.00	-8.40	AVG	100	277
7	15870.000	37.01	22.15	59.16	74.00	-14.84	peak	100	285
8	15870.000	22.07	22.15	44.22	54.00	-9.78	AVG	100	285
Antennal Polarity & Test Distance: Vertical at 3 m									
No.	Frequency (MHz)	Reading (dBuV)	Factor (dB)	Emission Level (dBuV/m)	Limit (dBuV/m)	Margin (dB)	Detector	Antenna Height (cm)	Table Angle (Degree)
1 *	5290.000	95.62	6.54	102.16			peak	206	259
2 *	5290.000	49.29	6.54	55.83			AVG	206	259
3	5350.000	60.08	6.34	66.42	74.00	-7.58	peak	206	259
4	5350.000	37.53	6.34	43.87	54.00	-10.13	AVG	206	259
5	10580.000	37.99	18.48	56.47	74.00	-17.53	peak	100	163
6	10580.000	24.42	18.48	42.90	54.00	-11.10	AVG	100	163
7	15870.000	37.07	22.15	59.22	74.00	-14.78	peak	100	330
8	15870.000	21.92	22.15	44.07	54.00	-9.93	AVG	100	330

1-Emission level (dBuV/m) = Raw Value (dBuV) + Correction Factor (dB/m).

2-Correction Factor (dB/m) = Antenna Factor (dB/m) + Cable Factor (dB).

3-The other emission levels were very low against the limit.

4-Margin value = Emission level – Limit value.

5- " \* ": Fundamental frequency.

Test Channel	TX Channel 106	Detector Function	Peak (PK) Average (AV)
Frequency Range	1GHz ~ 40GHz		

Antennal Polarity & Test Distance: Horizontal at 3 m									
No.	Frequency (MHz)	Reading (dBuV)	Factor (dB)	Emission Level (dBuV/m)	Limit (dBuV/m)	Margin (dB)	Detector	Antenna Height (cm)	Table Angle (Degree)
1 #	5470.000	59.35	6.50	65.85	68.20	-2.35	peak	287	269
2 *	5530.000	99.40	6.60	106.00			peak	287	269
3 *	5530.000	53.66	6.60	60.26			AVG	287	269
4	11060.000	40.49	19.37	59.86	74.00	-14.14	peak	100	264
5	11060.000	25.95	19.37	45.32	54.00	-8.68	AVG	100	264
6	16590.000	37.62	23.67	61.29	74.00	-12.71	peak	100	135
7	16590.000	22.24	23.67	45.91	54.00	-8.09	AVG	100	135
Antennal Polarity & Test Distance: Vertical at 3 m									
No.	Frequency (MHz)	Reading (dBuV)	Factor (dB)	Emission Level (dBuV/m)	Limit (dBuV/m)	Margin (dB)	Detector	Antenna Height (cm)	Table Angle (Degree)
1 #	5470.000	55.33	6.50	61.83	68.20	-6.37	peak	211	245
2 *	5530.000	94.77	6.60	101.37			peak	211	245
3 *	5530.000	50.89	6.60	57.49			AVG	211	245
4	11060.000	37.25	19.37	56.62	74.00	-17.38	peak	100	166
5	11060.000	22.33	19.37	41.70	54.00	-12.30	AVG	100	166
6	16590.000	37.45	23.67	61.12	74.00	-12.88	peak	100	60
7	16590.000	22.17	23.67	45.84	54.00	-8.16	AVG	100	60

1-Emission level (dBuV/m) = Raw Value (dBuV) + Correction Factor (dB/m).

2-Correction Factor (dB/m) = Antenna Factor (dB/m) + Cable Factor (dB).

3-The other emission levels were very low against the limit.

4-Margin value = Emission level – Limit value.

5- " \* ": Fundamental frequency.

6- " # ": The radiated frequency is out of the restricted band

Test Channel	TX Channel 122	Detector Function	Peak (PK) Average (AV)
Frequency Range	1GHz ~ 40GHz		

Antennal Polarity & Test Distance: Horizontal at 3 m									
No.	Frequency (MHz)	Reading (dBuV)	Factor (dB)	Emission Level (dBuV/m)	Limit (dBuV/m)	Margin (dB)	Detector	Antenna Height (cm)	Table Angle (Degree)
1 *	5610.000	100.22	6.75	106.97			peak	196	272
2 *	5610.000	53.51	6.75	60.26			AVG	196	272
3 #	5725.000	55.12	6.96	62.08	68.20	-6.12	peak	196	272
4	11220.000	40.02	19.52	59.54	74.00	-14.46	peak	100	266
5	11220.000	24.93	19.52	44.45	54.00	-9.55	AVG	100	266
6	16830.000	36.81	24.54	61.35	74.00	-12.65	peak	100	140
7	16830.000	22.64	24.54	47.18	54.00	-6.82	AVG	100	140
Antennal Polarity & Test Distance: Vertical at 3 m									
No.	Frequency (MHz)	Reading (dBuV)	Factor (dB)	Emission Level (dBuV/m)	Limit (dBuV/m)	Margin (dB)	Detector	Antenna Height (cm)	Table Angle (Degree)
1 *	5610.000	95.36	6.75	102.11			peak	201	248
2 *	5610.000	50.09	6.75	56.84			AVG	201	248
3 #	5725.000	54.49	6.96	61.45	68.20	-6.75	peak	201	248
4	11220.000	37.80	19.52	57.32	74.00	-16.68	peak	100	174
5	11220.000	22.37	19.52	41.89	54.00	-12.11	AVG	100	174
6	16830.000	36.77	24.54	61.31	74.00	-12.69	peak	100	290
7	16830.000	22.52	24.54	47.06	54.00	-6.94	AVG	100	290

1-Emission level (dBuV/m) = Raw Value (dBuV) + Correction Factor (dB/m).

2-Correction Factor (dB/m) = Antenna Factor (dB/m) + Cable Factor (dB).

3-The other emission levels were very low against the limit.

4-Margin value = Emission level – Limit value.

5- " \* ": Fundamental frequency.

6- " # ": The radiated frequency is out of the restricted band

Test Channel	TX Channel 155	Detector Function	Peak (PK) Average (AV)
Frequency Range	1GHz ~ 40GHz		

Antennal Polarity & Test Distance: Horizontal at 3 m									
No.	Frequency (MHz)	Reading (dBuV)	Factor (dB)	Emission Level (dBuV/m)	Limit (dBuV/m)	Margin (dB)	Detector	Antenna Height (cm)	Table Angle (Degree)
1 #	5650.000	55.06	6.82	61.88	68.20	-6.32	peak	211	316
2#	5725.000	69.14	6.96	76.10	122.20	-46.10	peak	211	316
3 *	5775.000	100.20	7.04	107.24	122.20	-14.96	peak	211	316
4 *	5775.000	57.98	7.04	65.02	122.20	-57.18	peak	211	316
5	5850.000	61.75	7.20	68.95	122.20	-53.25	peak	211	316
6	11550.000	41.10	19.76	60.86	74.00	-13.14	peak	127	258
7	11550.000	27.15	19.76	46.91	54.00	-7.09	AVG	127	258
8	17325.000	34.68	26.55	61.23	74.00	-12.77	peak	100	105
9	17325.000	20.47	26.55	47.02	54.00	-6.98	AVG	100	105
Antennal Polarity & Test Distance: Vertical at 3 m									
No.	Frequency (MHz)	Reading (dBuV)	Factor (dB)	Emission Level (dBuV/m)	Limit (dBuV/m)	Margin (dB)	Detector	Antenna Height (cm)	Table Angle (Degree)
1 #	5650.000	53.35	6.82	60.17	68.20	-8.03	peak	155	285
2#	5725.000	67.73	6.96	74.69	122.20	-47.51	peak	155	285
3 *	5775.000	96.83	7.04	103.87			peak	155	285
4 *	5775.000	54.10	7.04	61.14			peak	155	285
5	5850.000	59.32	7.20	66.52	122.20	-55.68	peak	155	285
6	11550.000	37.67	19.76	57.43	74.00	-16.57	peak	100	173
7	11550.000	23.92	19.76	43.68	54.00	-10.32	AVG	100	173
8	17325.000	34.62	26.55	61.17	74.00	-12.83	peak	100	30
9	17325.000	20.55	26.55	47.10	54.00	-6.90	AVG	100	30

1-Emission level (dBuV/m) = Raw Value (dBuV) + Correction Factor (dB/m).

2-Correction Factor (dB/m) = Antenna Factor (dB/m) + Cable Factor (dB).

3-The other emission levels were very low against the limit.

4-Margin value = Emission level – Limit value.

5- " \* ": Fundamental frequency.

6- " # ": The radiated frequency is out of the restricted band

### 3.2 Conducted emission measurement

#### 3.2.1 Limits of conducted emission measurement

Frequency of emission (MHz)	Conducted limit (dB $\mu$ V)	
	Quasi-peak	Average
0.15 ~ 0.5	66 to 56	56 to 46
0.5 ~ 5	56	46
5 ~ 30	60	50

- NOTE:**
1. The lower limit shall apply at the transition frequencies.
  2. The limit decreases in line with the logarithm of the frequency in the range of 0.15 to 0.50MHz.
  3. All emanations from a class A/B digital device or system, including any network of conductors and apparatus connected thereto, shall not exceed the level of field strengths specified above.

#### 3.2.2 Test instruments

Description & Manufacturer	Model No.	Serial No.	Date of Calibration	Due Date of Calibration
EMI Test Receiver Rohde&Schwarz	ESCI3	101418	2019-1-5	2020-1-4
Artificial Mains Network Rohde&Schwarz	ENV216	3560.6550.15	2018-11-12	2019-11-11
Test software FARAD	EZ_EMC V1.1.4.2	N/A	N/A	N/A
Hygrothermograph Yuhuaze	HTC-1	NA	2018-10-30	2019-10-29
Digital Multimeter FLUKE	15B+	43512617WS	2018-11-10	2019-11-09

- Note:
1. The calibration interval of the above test instruments is 12 months and the calibrations are traceable to CEPREI/CHINA.
  2. The test was performed in Shielded Room 743.

### 3.2.3 Test procedures

- The EUT was placed 0.4 meters from the conducting wall of the shielded room with EUT being connected to the power mains through a line impedance stabilization network (LISN). Other support units were connected to the power mains through another LISN. The two LISNs provide 50 ohm/ 50uH of coupling impedance for the measuring instrument.
- Both lines of the power mains connected to the EUT were checked for maximum conducted interference.
- The frequency range from 150kHz to 30MHz was searched. Emission levels under (Limit - 20dB) were not recorded.

**Note:** All modes of operation were investigated and the worst-case emissions are reported.

### 3.2.4 Deviation from test standard

No deviation.

### 3.2.5 Test setup

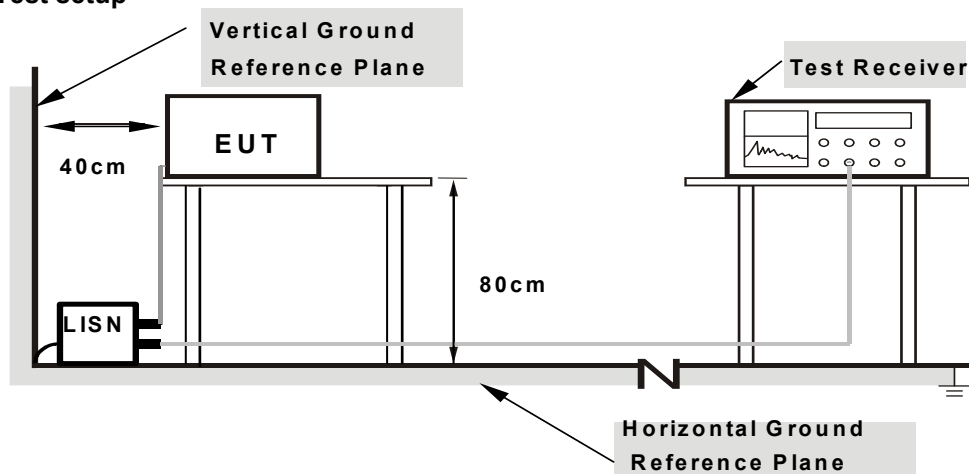

- Note:**
- Support units were connected to second LISN.
  - Both of LISNs (AMN) are 80 cm from EUT and at least 80 from other units and other metal planes

For the actual test configuration, please refer to the attached file (Test Setup Photo).

### 3.2.6 EUT operating conditions

Same as 2.4

### 3.2.7 Test results

Conducted worst-case data: 802.11a

Frequency Range	150kHz ~ 30MHz	Detector Function & Resolution band width	Quasi-Peak (QP) /Average (AV), 9kHz
Input Power	DC 5V from USB		

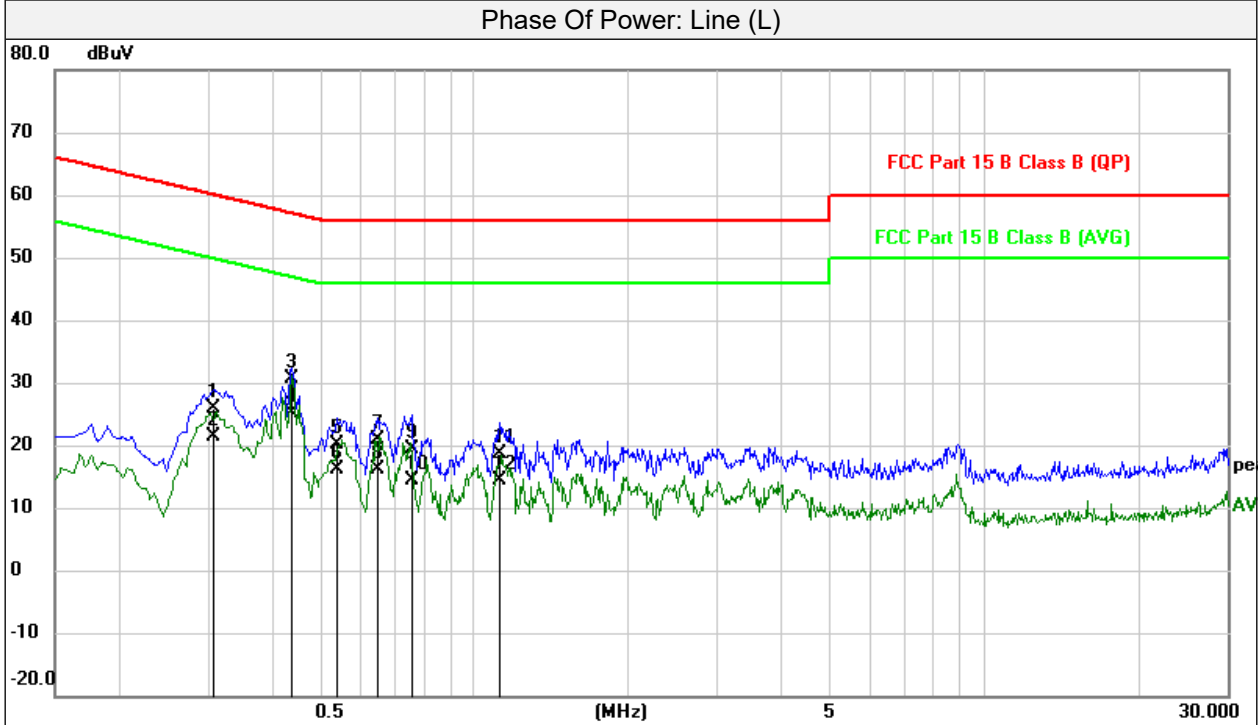

No	Frequency (MHz)	Reading (dBuV)	Correct Factor	Emission Level	Limit	Margin	Remark
			dB	(dBuV)	(dBuV)	(dB)	Detector
1	0.3075	16.20	9.61	25.81	60.04	-34.23	QP
2	0.3075	11.75	9.61	21.36	50.04	-28.68	AVG
3	0.4380	21.12	9.58	30.70	57.10	-26.40	QP
4	0.4380	15.49	9.58	25.07	47.10	-22.03	AVG
5	0.5370	10.49	9.59	20.08	56.00	-35.92	QP
6	0.5370	6.53	9.59	16.12	46.00	-29.88	AVG
7	0.6450	11.30	9.59	20.89	56.00	-35.11	QP
8	0.6450	6.50	9.59	16.09	46.00	-29.91	AVG
9	0.7530	9.69	9.59	19.28	56.00	-36.72	QP
10	0.7530	4.81	9.59	14.40	46.00	-31.60	AVG
11	1.1220	9.04	9.55	18.59	56.00	-37.41	QP
12	1.1220	4.93	9.55	14.48	46.00	-31.52	AVG

- Remarks:**
1. Q.P. and AV. are abbreviations of quasi-peak and average individually.
  2. The emission levels of other frequencies were very low against the limit.
  3. Margin value = Emission level - Limit value
  4. Correction factor = Insertion loss + Cable loss
  5. Emission Level = Correction Factor + Reading Value.

Frequency Range	150kHz ~ 30MHz	Detector Function & Resolution band width	Quasi-Peak (QP)/Average (AV), 9kHz
Input Power	DC 5V from USB		

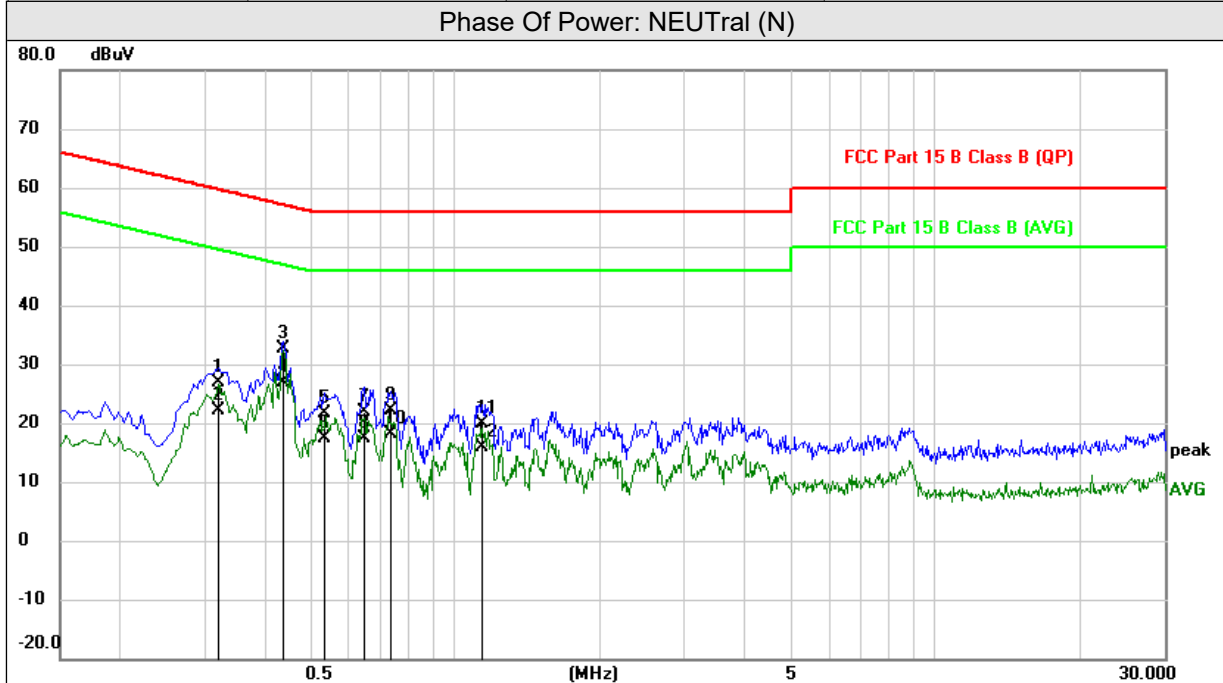

No	Frequency (MHz)	Reading (dBuV)	Correct Factor	Emission Level	Limit	Margin	Remark
			dB	(dBuV)	(dBuV)	(dB)	
1	0.3209	17.28	9.61	26.89	59.68	-32.79	QP
2	0.3209	12.58	9.61	22.19	49.68	-27.49	AVG
3	0.4380	22.97	9.58	32.55	57.10	-24.55	QP
4	0.4380	17.34	9.58	26.92	47.10	-20.18	AVG
5	0.5325	12.04	9.59	21.63	56.00	-34.37	QP
6	0.5325	7.80	9.59	17.39	46.00	-28.61	AVG
7	0.6450	12.37	9.59	21.96	56.00	-34.04	QP
8	0.6450	7.70	9.59	17.29	46.00	-28.71	AVG
9	0.7350	12.65	9.59	22.24	56.00	-33.76	QP
10	0.7350	8.43	9.59	18.02	46.00	-27.98	AVG
11	1.1355	10.32	9.55	19.87	56.00	-36.13	QP
12	1.1355	6.34	9.55	15.89	46.00	-30.11	AVG

- Remarks:**
1. Q.P. and AV. are abbreviations of quasi-peak and average individually.
  2. The emission levels of other frequencies were very low against the limit.
  3. Margin value = Emission level - Limit value
  4. Correction factor = Insertion loss + Cable loss
  5. Emission Level = Correction Factor + Reading Value.



### 3.3 Transmit power measurement

#### 3.3.1 Limits of transmit power measurement

Operation Band	EUT Category		Limit
U-NII-1	-	Outdoor Access Point	1 Watt (30 dBm) (Max. e.i.r.p ≤ 125mW(21 dBm) at any elevation angle above 30 degrees as measured from the horizon)
	-	Fixed point-to-point Access Point	1 Watt (30 dBm)
	-	Indoor Access Point	1 Watt (30 dBm)
	√	Mobile and Portable client device	250mW (24 dBm)
U-NII-2A	√		250mW(24dBm) or 11 dBm+10LogB*
U-NII-2C	√		250mW(24dBm) or 11 dBm+10LogB*
U-NII-3	√		1 Watt (30 dBm)

**NOTE:** 1. Where B is the 26dB emission bandwidth in MHz.

#### 3.3.2 Test setup

For conducted power measurement setup:

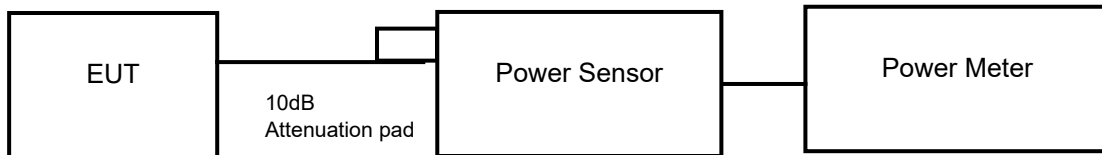

For 6/26dB bandwidth test setup

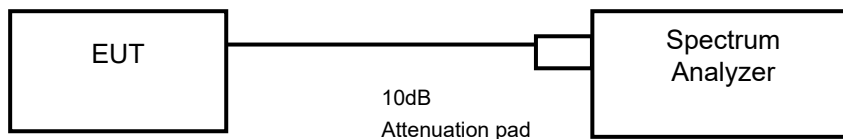

### 3.3.3 Test instruments

Description & Manufacturer	Model No.	Serial No.	Date of Calibration	Due Date of Calibration
Spectrum Keysight	N9020A	MY51240612	2018/10/29	2019/10/28
Spectrum Analyzer Rohde&Schwarz	FSV-40N	101783	2018/12/11	2019/12/10
Power Meter10Hz~18GHz Tonscend	JS0806-2	188060126	2018-11-10	2019-11-09
Signal generator Keysight	N5182A	GB40051020	2018/10/29	2019/10/28
Signal generator Keysight	N5182A	MY47420944	2018/10/29	2019/10/28
Test Software Tonscend	JS0806-2	NA	NA	NA
Hygrothermograph Yuhuaze	HTC-1	NA	2018/10/30	2019/10/29

Note: 3. The calibration interval of the above test instruments is 12 months and the calibrations are traceable to CEPREI/CHINA.

4. The test was performed in Chamber 1.

### 3.3.4 Test procedure

\*For average power measurement:

Method PM is used to perform output power measurement, trigger and gating function of wide band power meter is enabled to measure max output power of TX on burst. Duty factor is not added to measured value.

\*For 26dB bandwidth measurement:

- 1) Set RBW = approximately 1% of the emission bandwidth.
- 2) Set the VBW > RBW.
- 3) Detector = RMS.
- 4) Trace mode = max hold.
- 5) Measure the maximum width of the emission that is 26 dB down from the peak of the emission. Compare this with the RBW setting of the analyzer. Readjust RBW and repeat measurement as needed until the RBW/EBW ratio is approximately 1%.

\*For 6dB bandwidth measurement:

- 1) Set RBW = 100 kHz.
- 2) Set the video bandwidth (VBW)  $\geq$  3 RBW.
- 3) Detector = Peak.
- 4) Trace mode = max hold.
- 5) Sweep = auto couple.
- 6) Allow the trace to stabilize.
- 7) Measure the maximum width of the emission that is constrained by the frequencies associated with the two outermost amplitude points (upper and lower frequencies) that are attenuated by 6 dB relative to the maximum level measured in the fundamental emission.

### 3.3.5 Deviation from test standard

No deviation.

### 3.3.6 EUT operating conditions

The software provided by client to enable the EUT under transmission condition continuously at specific channel frequencies individually.

**3.3.7 Test results**
**Conducted Output power:**
**802.11a**

Channel Number	Freq. (MHz)	AVG. conducted power (dBm)		AVG. conducted power (mW)		Total Max. power output		Limit (dBm)	PASS /FAIL
		Chain 0	Chain 1	Chain 0	Chain 1	mW	dBm		
36	5180	12.26	12.40	16.83	17.38	34.20	15.34	24.00	PASS
40	5200	12.72	12.68	18.71	18.54	37.24	15.71	24.00	PASS
48	5240	12.53	12.39	17.91	17.34	35.24	15.47	24.00	PASS
52	5260	12.69	13.14	18.58	20.61	39.18	15.93	24.00	PASS
60	5300	13.13	13.56	20.56	22.70	43.26	16.36	24.00	PASS
64	5320	13.55	13.86	22.65	24.32	46.97	16.72	24.00	PASS
100	5500	14.18	14.45	26.18	27.86	54.04	17.33	24.00	PASS
120	5600	14.37	14.49	27.35	28.12	55.47	17.44	24.00	PASS
140	5700	14.23	14.39	26.49	27.48	53.96	17.32	24.00	PASS
149	5745	17.38	16.92	54.70	49.20	103.91	20.17	30.00	PASS
157	5785	17.33	17.02	54.08	50.35	104.43	20.19	30.00	PASS
165	5825	16.84	17.14	48.31	51.76	100.07	20.00	30.00	PASS

**For Band 2~Band 3:**

- 1.Limit = 11dBm+10log(26 BW)=11+10\*log(21.40)=24.30dBm > 24dBm
- 2.Limit = 11dBm+10log(26 BW)=11+10\*log(20.16)=24.04dBm > 24dBm
- 3.Limit = 11dBm+10log(26 BW)=11+10\*log(20.64)=24.15dBm > 24dBm
- 4.Limit = 11dBm+10log(26 BW)=11+10\*log(20.20)=24.05dBm > 24dBm
- 5.Limit = 11dBm+10log(26 BW)=11+10\*log(21.36)=24.30dBm > 24dBm
- 6.Limit = 11dBm+10log(26 BW)=11+10\*log(20.08)=24.04dBm > 24dBm

**802.11ac (80MHz)**

Channel Number	Freq. (MHz)	AVG. conducted power (dBm)		AVG. Conducted power (mW)		Total Max. power output		Limit (dBm)	PASS /FAIL
		Chain 0	Chain 1	Chain 0	Chain 1	mW	dBm		
42	5210	12.48	12.07	17.70	16.11	33.81	15.29	24.00	PASS
58	5290	11.62	12.18	14.52	16.52	31.04	14.92	24.00	PASS
106	5530	12.36	11.75	17.22	14.96	32.18	15.08	24.00	PASS
122	5610	15.28	15.39	33.73	34.59	68.32	18.35	24.00	PASS
155	5775	15.54	15.73	35.81	37.41	73.22	18.65	30.00	PASS

**802.11n (20MHz)**

Channel Number	Freq. (MHz)	AVG. conducted power (dBm)		AVG. conducted power (mW)		Total Max. power output		Limit (dBm)	PASS /FAIL
		Chain 0	Chain 1	Chain 0	Chain 1	mW	dBm		
36	5180	12.33	12.17	17.10	16.48	33.58	15.26	24.00	PASS
40	5200	12.08	11.96	16.14	15.70	31.85	15.03	24.00	PASS
48	5240	12.36	11.85	17.22	15.31	32.53	15.12	24.00	PASS
52	5260	11.25	11.39	13.34	13.77	27.11	14.33	24.00	PASS
60	5300	11.78	11.68	15.07	14.72	29.79	14.74	24.00	PASS
64	5320	12.26	12.01	16.83	15.89	32.71	15.15	24.00	PASS
100	5500	14.05	13.58	25.41	22.80	48.21	16.83	24.00	PASS
120	5600	14.27	13.74	26.73	23.66	50.39	17.02	24.00	PASS
140	5700	13.87	14.21	24.38	26.36	50.74	17.05	24.00	PASS
149	5745	17.63	17.25	57.94	53.09	111.03	20.45	30.00	PASS
157	5785	17.56	17.18	57.02	52.24	109.26	20.38	30.00	PASS
165	5825	17.09	17.27	51.17	53.33	104.50	20.19	30.00	PASS

**For Band 2~Band 3:**

- 1.Limit = 11dBm+10log(26 BW)=11+10\*log(20.36)=24.09dBm > 24dBm
- 2.Limit = 11dBm+10log(26 BW)=11+10\*log(20.08)=24.03dBm > 24dBm
- 3.Limit = 11dBm+10log(26 BW)=11+10\*log(20.16)=24.04dBm > 24dBm
- 4.Limit = 11dBm+10log(26 BW)=11+10\*log(20.20)=24.05dBm > 24dBm
- 5.Limit = 11dBm+10log(26 BW)=11+10\*log(21.28)=24.07dBm > 24dBm
- 6.Limit = 11dBm+10log(26 BW)=11+10\*log(20.08)=24.03dBm > 24dBm

**802.11n (40MHz)**

Channel Number	Freq. (MHz)	AVG. conducted power (dBm)		AVG. conducted power (mW)		Total Max. power output		Limit (dBm)	PASS /FAIL
		Chain 0	Chain 1	Chain 0	Chain 1	mW	dBm		
38	5190	12.78	12.94	18.97	19.68	38.65	15.87	24.00	PASS
46	5230	12.72	12.49	18.71	17.74	36.45	15.62	24.00	PASS
54	5270	11.72	12.21	14.86	16.63	31.49	14.98	24.00	PASS
62	5310	12.56	13.13	18.03	20.56	38.59	15.86	24.00	PASS
102	5510	13.54	13.39	22.59	21.83	44.42	16.48	24.00	PASS
118	5590	13.98	13.72	25.00	23.55	48.55	16.86	24.00	PASS
134	5670	13.90	13.69	24.55	23.39	47.94	16.81	24.00	PASS
151	5755	18.06	17.78	63.97	59.98	123.95	20.93	24.00	PASS
159	5795	18.14	17.74	65.16	59.43	124.59	20.95	30.00	PASS

26dB bandwidth:

802.11a

Channel Number	Freq. (MHz)	26dBc bandwidth (MHz)		PASS /FAIL
		Chain 0	Chain 1	
36	5180	20.04	19.84	PASS
40	5200	20.48	19.72	PASS
48	5240	20.32	19.88	PASS
52	5260	<b>21.40</b>	20.08	PASS
60	5300	20.16	20.20	PASS
64	5320	20.64	20.08	PASS
100	5500	20.20	20.32	PASS
116	5580	21.36	20.40	PASS
140	5700	20.16	20.08	PASS

Spectrum plot of worst value

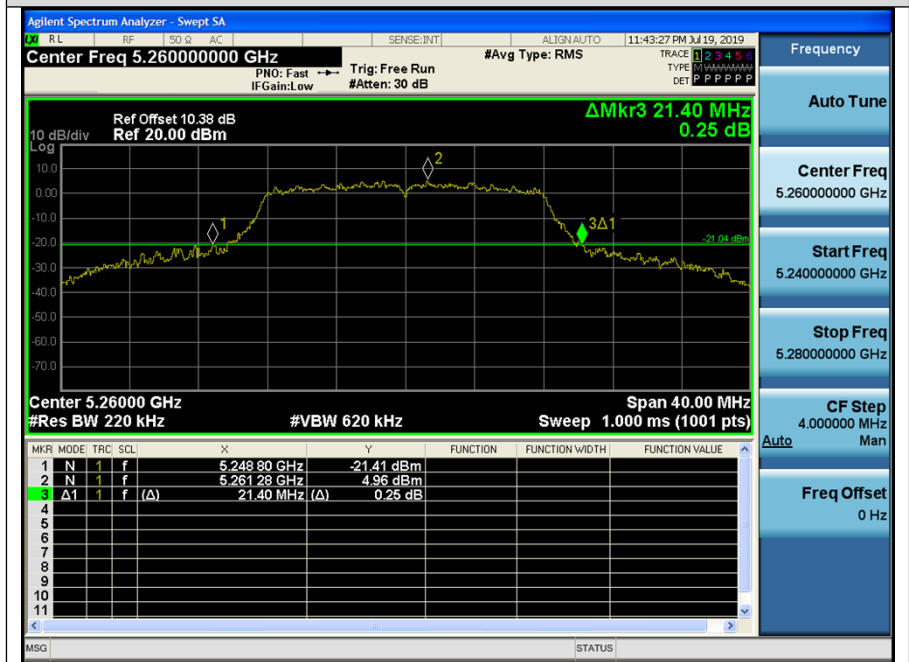

802.11ac (80MHz)

Channel Number	Freq. (MHz)	26dBc bandwidth (MHz)		PASS /FAIL
		Chain 0	Chain 1	
42	5210	81.10	80.80	PASS
58	5290	80.64	80.80	PASS
106	5530	81.12	81.10	PASS
122	5610	81.04	80.96	PASS

Spectrum plot of worst value



802.11n (20MHz)

Channel Number	Freq. (MHz)	26dBc bandwidth (MHz)		PASS /FAIL
		Chain 0	Chain 1	
36	5180	20.16	20.10	PASS
40	5200	20.20	20.16	PASS
48	5240	20.16	20.16	PASS
52	5260	20.36	20.28	PASS
60	5280	20.08	<b>20.80</b>	PASS
64	5320	20.16	20.48	PASS
100	5500	20.20	20.28	PASS
116	5580	20.28	20.72	PASS
140	5700	20.08	20.12	PASS

Spectrum plot of worst value





802.11n (40MHz)

Channel Number	Freq. (MHz)	26dBc bandwidth (MHz)		PASS /FAIL
		Chain 0	Chain 1	
38	5190	40.40	40.48	PASS
46	5230	40.40	40.42	PASS
54	5270	40.24	40.80	PASS
62	5310	40.72	40.64	PASS
102	5510	41.20	<b>41.28</b>	PASS
118	5590	40.40	40.96	PASS
134	5670	40.48	40.40	PASS

Spectrum plot of worst value

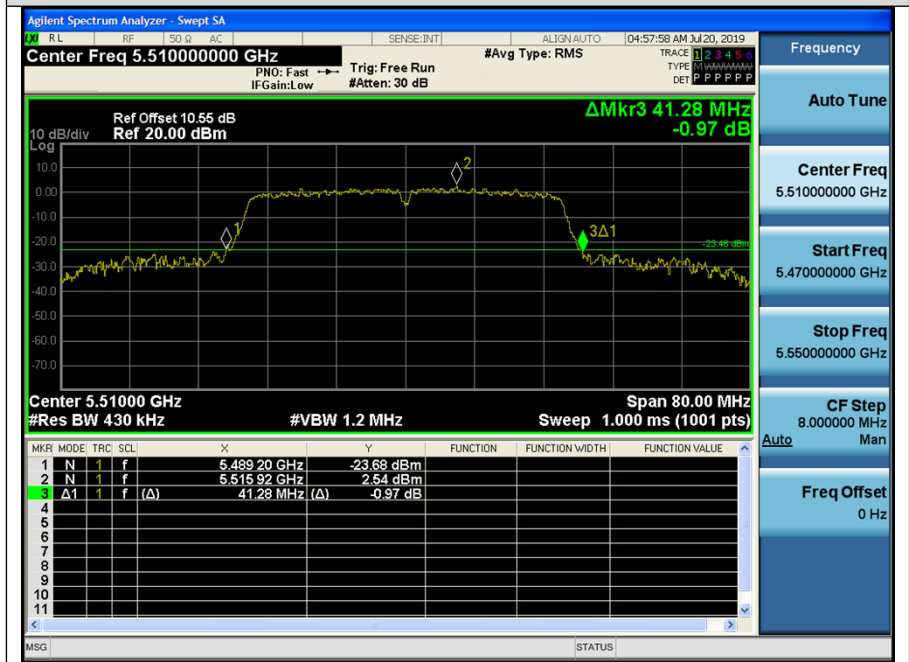

6dB bandwidth for 5725-5850MHz

802.11a



802.11n (20M)

Channel Number	Freq. (MHz)	6dBc bandwidth (MHz)		PASS /FAIL
		Chain 0	Chain 1	
149	5745	15.16	15.16	PASS
157	5785	15.16	15.16	PASS
165	5825	15.20	15.16	PASS

Spectrum plot of worst value



802.11n (40M)

Channel Number	Freq. (MHz)	6dBc bandwidth (MHz)		PASS /FAIL
		Chain 0	Chain 1	
151	5755	35.28	35.28	PASS
159	5795	35.28	35.28	PASS

Spectrum plot of worst value

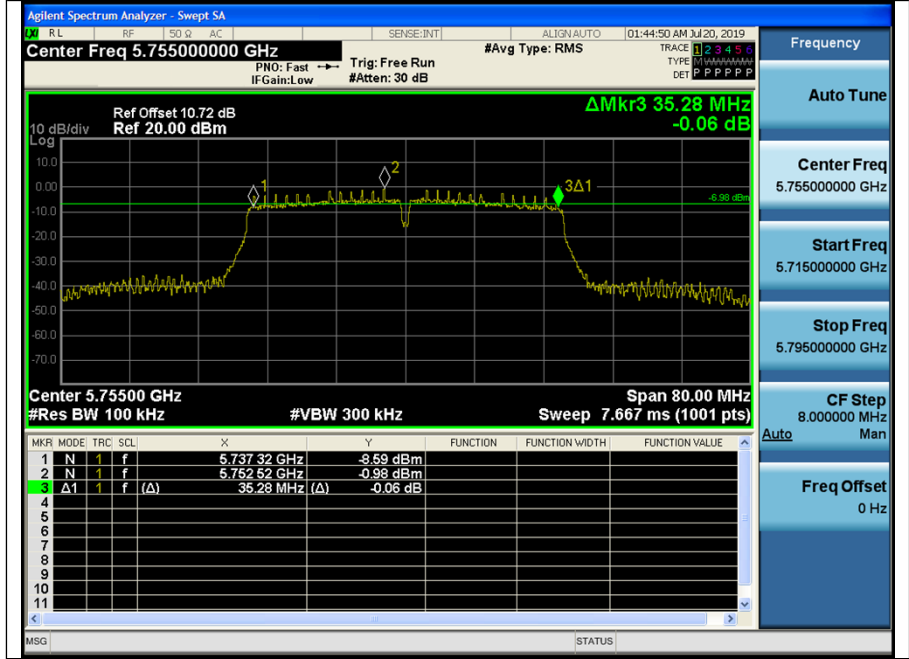

802.11ac (80MHz)

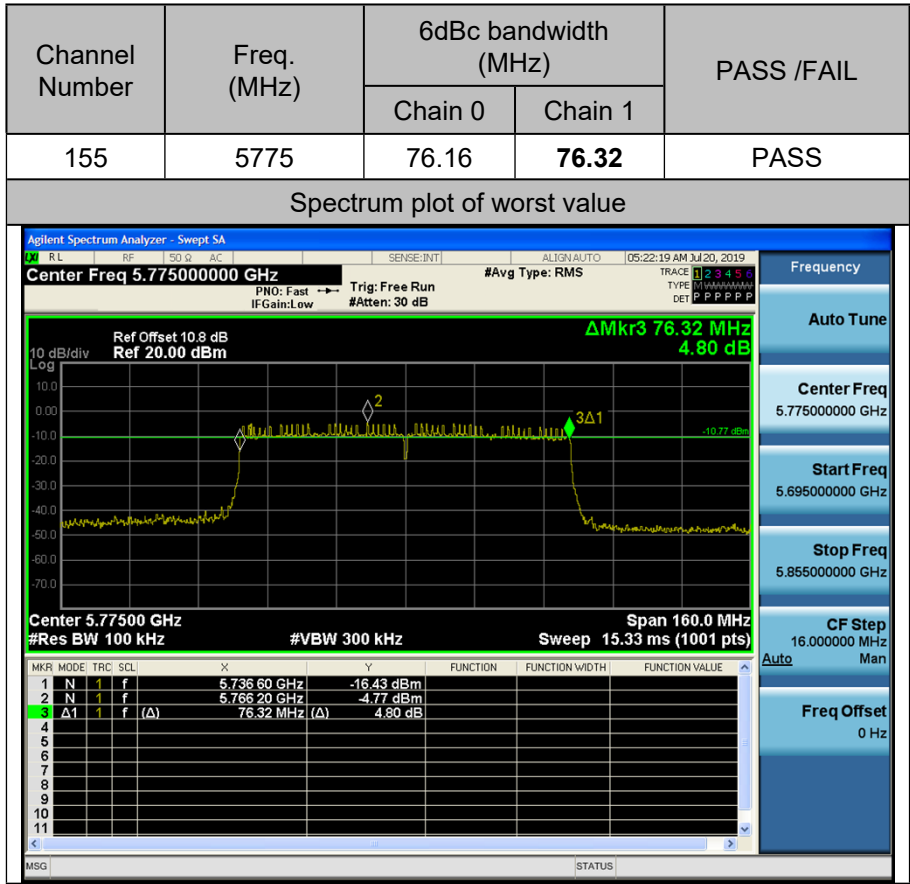

### 3.4 Peak power spectral density measurement

#### 3.4.1 Limits of peak power spectral density measurement

Operation Band	EUT Category		Limit
U-NII-1	-	Outdoor Access Point	17dBm/ MHz
	-	Fixed point-to-point Access Point	
	-	Indoor Access Point	
	√	Mobile and Portable client device	11dBm/ MHz
U-NII-2A	√		11dBm/ MHz
U-NII-2C	√		11dBm/ MHz
U-NII-3	√		30dBm/ 500kHz

#### 3.4.2 Test setup

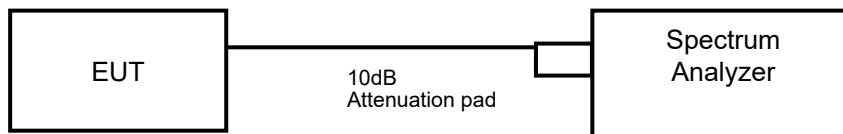

#### 3.4.3 Test instruments

Refer to section 3.3.3 to get information of above instrument.

#### 3.4.4 Test procedures

##### For U-NII-1, U-NII-2A, U-NII-2C band:

Using method SA-2

- 1) Set span to encompass the entire emission bandwidth (EBW) of the signal.
- 2) Set RBW = 1MHz, Set VBW =3 MHz, Detector = RMS
- 3) Set Channel power measure = 1MHz
- 4) Sweep time = auto, trigger set to “free run”.
- 5) Trace average at least 100 traces in power averaging mode.
- 6) Record the max value and add 10 log (1/duty cycle)

##### For U-NII-3 band:

Using method SA-2

- 1) Set span to encompass the entire emission bandwidth (EBW) of the signal.
- 2) Set RBW = 300 kHz, Set VBW =1 MHz, Detector = RMS
- 3) Set Channel power measure = 1MHz
- 4) Sweep time = auto, trigger set to “free run”.
- 5) Trace average at least 100 traces in power averaging mode.
- 6) Record the max value and add 10 log (1/duty cycle)

**Dutycycle factor:**

**Chain 0: Duty cycle of test signal<98%**

**802.11a** Duty cycle of test signal is 97.34%, duty cycle factor= $10 \cdot \log(1/0.9734)=0.11\text{dB}$

**802.11n HT20** Duty cycle of test signal is 97.15%, duty cycle factor= $10 \cdot \log(1/0.9715)=0.12\text{dB}$

**802.11n HT40** Duty cycle of test signal is 94.34%, duty cycle factor= $10 \cdot \log(1/0.9437)=0.25\text{dB}$

**802.11ac VHT80** Duty cycle of test signal is 82.95%, duty cycle factor= $10 \cdot \log(1/0.8295)=0.81\text{dB}$

**Chain 1: Duty cycle of test signal<98%**

802.11a Duty cycle of test signal is 97.34%, duty cycle factor= $10 \cdot \log(1/0.9734)=0.11\text{dB}$

802.11n HT20 Duty cycle of test signal is 97.66%, duty cycle factor= $10 \cdot \log(1/0.9766)=0.10\text{dB}$

802.11n HT40 Duty cycle of test signal is 94.43%, duty cycle factor= $10 \cdot \log(1/0.9443)=0.25\text{dB}$

802.11ac VHT80 Duty cycle of test signal is 83.05%, duty cycle factor= $10 \cdot \log(1/0.8305)=0.81\text{dB}$

Operation mode	Duty cycle Factor(dB)	
	Chain 0	Chain 1
802.11a	0.11	0.11
802.11n HT20	0.12	0.10
802.11n HT40	0.25	0.25
802.11ac VHT80	0.81	0.81

**3.4.5 Deviation from test standard**

No deviation.

**3.4.6 EUT operating conditions**

Same as 3.3.6

### 3.4.7 Test results

#### For U-NII-1, U-NII-2A & U-NII-2C, For U-NII-3: 802.11a

Channel Number	Frequency (MHz)	RF Power Level in 1MHz BW (dBm)		Total power density (mW)		Total power density		Total power add dutycycle factor(dBm)	Limit (dBm)
		Chain 0	Chain 1	Chain 0	Chain 1	mW	dBm		
36	5180	7.01	6.51	5.0234	4.4771	9.5006	9.78	9.89	10.01
40	5200	6.82	6.43	4.8084	4.3954	9.2038	9.64	9.75	10.01
48	5240	6.71	6.49	4.6881	4.4566	9.1447	9.61	9.72	10.01
52	5260	7.04	6.54	5.0582	4.5082	9.5664	9.81	9.92	10.18
60	5300	6.73	6.55	4.7098	4.5186	9.2283	9.65	9.76	10.18
64	5320	<b>7.14</b>	6.61	5.1761	4.5814	9.7575	9.89	10.00	10.18
100	5500	6.42	<b>7.41</b>	4.3853	5.5081	9.8934	9.95	10.06	10.49
116	5580	6.41	6.90	4.3752	4.8978	9.2730	9.67	9.78	10.49
140	5700	6.57	6.94	4.5394	4.9431	9.4825	9.77	9.88	10.49

Note:

- Method 1 of power density measurement of KDB 662911 is using for calculating total power density. Total power density is summing entire spectra across ponding frequency bins on the various outputs by computer
- For 5150~5250MHz: Directional gain = 3.98dBi + 10\*log(2) = 6.99dBi < 6dBi, so the power density limit need to reduce 0.99dB.
- For 5250~5350MHz: Directional gain = 3.81dBi + 10\*log(2) = 6.82dBi < 6dBi, so the power density limit need to reduce 0.82dB.
- For 5470~5725MHz: Directional gain = 3.50dBi + 10\*log(2) = 6.51dBi < 6dBi, so the power density limit need to reduce 0.51dB.

Channel Number	Frequency (MHz)	RF Power Level in 300kHz BW (dBm)		RF Power Level in 500kHz BW (dBm)		Total PSD (dBm/500kHz)	Total power add dutycycle factor(dBm)	Limit (dBm)
		Chain 0	Chain 1	Chain 0	Chain 1			
149	5745	<b>4.41</b>	<b>4.62</b>	6.63	6.84	9.43	9.54	30.00
157	5785	3.65	4.43	5.87	6.65	8.48	8.59	30.00
165	5825	3.98	4.44	6.20	6.66	8.80	8.91	30.00

Note:

- Method 1 of power density measurement of KDB 662911 is using for calculating total power density. Total power density is summing entire spectra across ponding frequency bins on the various outputs by computer
- For 5725~5850MHz: Directional gain = 2.56dBi + 10\*log(2) = 5.57dBi < 6dBi, so the power density limit no need to reduce.



Spectrum plot of worst value

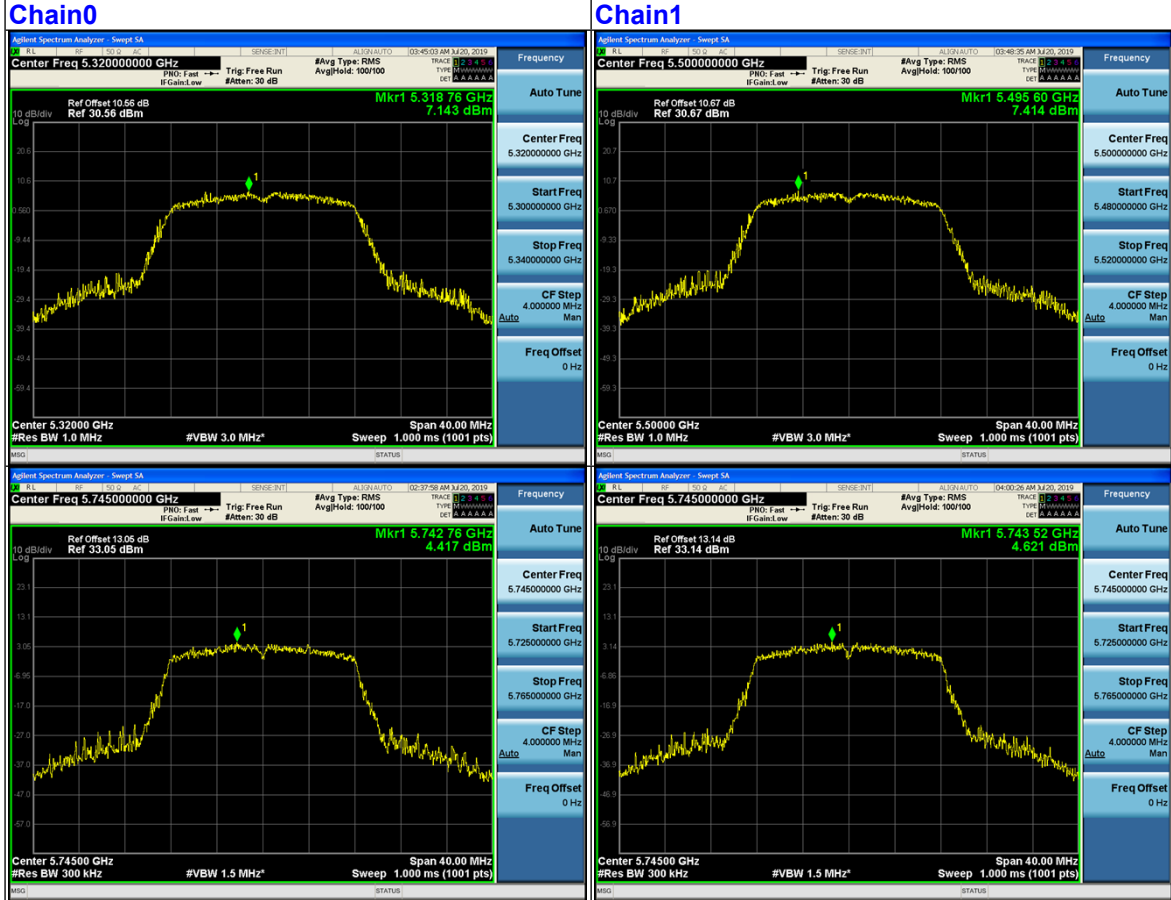

**802.11n (20MHz)**

Channel Number	Frequency (MHz)	RF Power Level in 1MHz BW (dBm)		Total power density (mW)		Total power density		Total power add dutycycle factor(dBm)	Limit (dBm)
		Chain 0	Chain 1	Chain 0	Chain 1	mW	dBm		
36	5180	6.53	6.55	4.4978	4.5186	9.0164	9.55	9.66	10.01
40	5200	6.19	6.18	4.1591	4.1495	8.3086	9.20	9.31	10.01
48	5240	5.99	6.14	3.9719	4.1115	8.0834	9.08	9.19	10.01
52	5260	6.15	6.73	4.1210	4.7098	8.8307	9.46	9.57	10.18
56	5280	<b>6.69</b>	<b>7.18</b>	4.6666	5.2240	9.8906	9.95	10.06	10.18
64	5320	6.22	6.75	4.1879	4.7315	8.9194	9.50	9.61	10.18
100	5500	6.16	6.56	4.1305	4.5290	8.6595	9.37	9.48	10.49
116	5580	6.66	6.49	4.6345	4.4566	9.0910	9.59	9.70	10.49
140	5700	5.94	6.44	3.9264	4.4055	8.3320	9.21	9.32	10.49

Note:

- Method 1 of power density measurement of KDB 662911 is using for calculating total power density. Total power density is summing entire spectra across ponding frequency bins on the various outputs by computer
- For 5150~5250MHz: Directional gain = 3.98dBi + 10\*log (2) = 6.99dBi < 6dBi, so the power density limit need to reduce 0.99dB.
- For 5250~5350MHz: Directional gain = 3.81dBi + 10\*log (2) = 6.82dBi < 6dBi, so the power density limit need to reduce 0.82dB.
- For 5470~5725MHz: Directional gain = 3.50dBi + 10\*log (2) = 6.51dBi < 6dBi, so the power density limit need to reduce 0.51dB.

Channel Number	Frequency (MHz)	RF Power Level in 300kHz BW (dBm)		RF Power Level in 500kHz BW (dBm)		Total PSD (dBm/500kHz)	Total power add dutycycle factor(dBm)	Limit (dBm)
		Chain 0	Chain 1	Chain 0	Chain 1			
149	5745	3.87	3.99	6.09	6.21	8.24	8.35	30.00
157	5785	<b>4.19</b>	<b>5.21</b>	6.36	7.43	9.86	9.97	30.00
165	5825	3.59	4.19	5.81	6.41	8.18	8.29	30.00

Note:

- Method 1 of power density measurement of KDB 662911 is using for calculating total power density. Total power density is summing entire spectra across ponding frequency bins on the various outputs by computer
- For 5725~5850MHz: Directional gain = 2.56dBi + 10\*log (2) = 5.57dBi < 6dBi, so the power density limit no need to reduce.

Spectrum plot of worst value

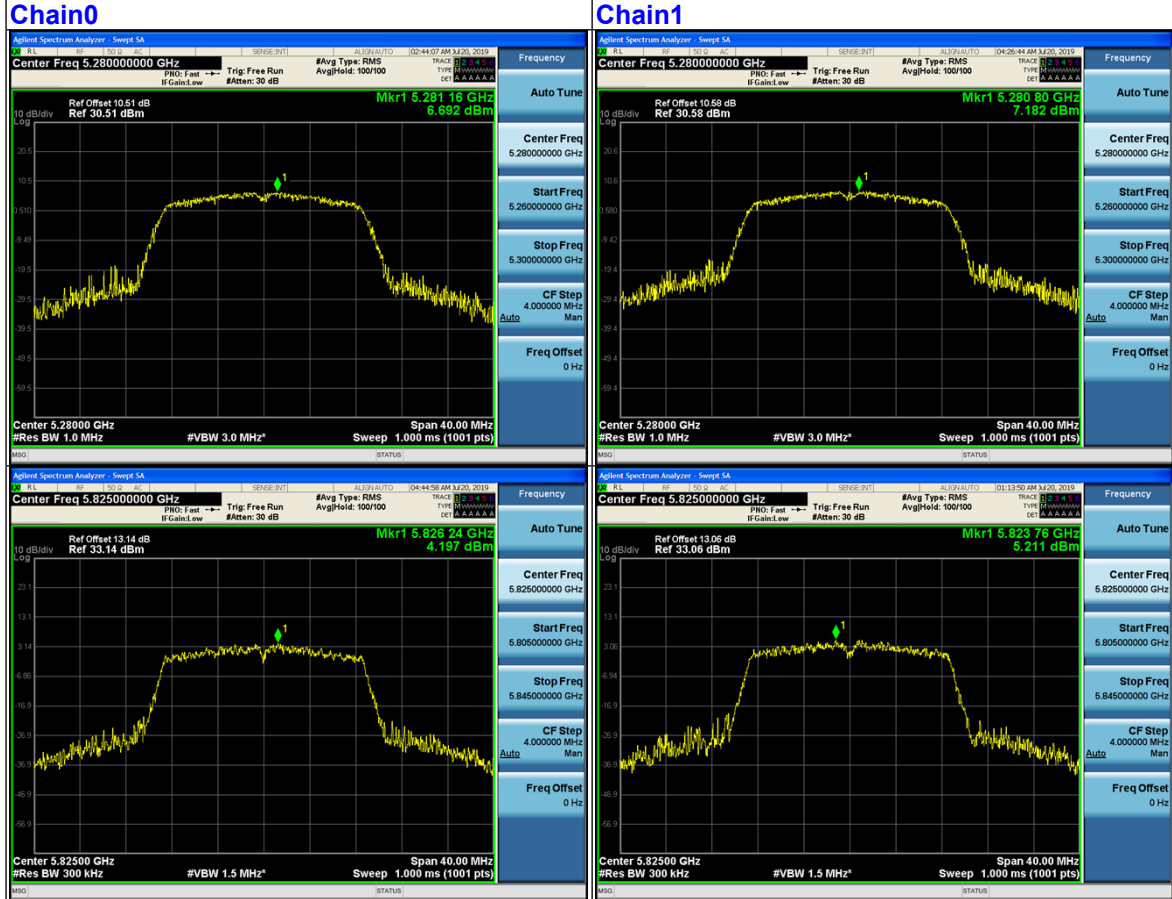

**802.11n (40MHz)**

Channel Number	Frequency (MHz)	RF Power Level in 1MHz BW (dBm)		Total power density (mW)		Total power density		Total power add dutycycle factor(dBm)	Limit (dBm)
		Chain 0	Chain 1	Chain 0	Chain 1	mW	dBm		
38	5190	3.92	3.65	2.4660	2.3174	4.7834	6.80	7.05	10.01
46	5230	3.52	4.13	2.2491	2.5882	4.8373	6.85	7.10	10.01
54	5270	4.38	4.52	2.7416	2.8314	5.5730	7.46	7.71	10.18
62	5310	4.00	3.89	2.5119	2.4491	4.9609	6.96	7.21	10.18
102	5510	3.72	4.11	2.3550	2.5763	4.9314	6.93	7.18	10.49
112	5550	<b>4.64</b>	<b>4.61</b>	2.9107	2.8907	5.8014	7.64	7.89	10.49
134	5670	4.59	4.50	2.8774	2.8184	5.6958	7.56	7.81	10.49

## Note:

- Method 1 of power density measurement of KDB 662911 is using for calculating total power density. Total power density is summing entire spectra across ponding frequency bins on the various outputs by computer
- For 5150~5250MHz: Directional gain = 3.98dBi + 10\*log (2) = 6.99dBi < 6dBi, so the power density limit need to reduce 0.99dB.
- For 5250~5350MHz: Directional gain = 3.81dBi + 10\*log (2) = 6.82dBi < 6dBi, so the power density limit need to reduce 0.82dB.
- For 5470~5725MHz: Directional gain = 3.50dBi + 10\*log (2) = 6.51dBi < 6dBi, so the power density limit need to reduce 0.51dB.

Channel Number	Frequency (MHz)	RF Power Level in 300kHz BW (dBm)		RF Power Level in 500kHz BW (dBm)		Total PSD (dBm /500kHz)	Total power add dutycycle factor(dBm)	Limit (dBm)
		Chain 0	Chain 1	Chain 0	Chain 1			
151	5755	<b>1.95</b>	<b>2.00</b>	4.17	4.22	5.25	5.50	30
159	5795	1.78	1.45	4.00	3.67	4.84	5.09	30

## Note:

- Method 1 of power density measurement of KDB 662911 is using for calculating total power density. Total power density is summing entire spectra across ponding frequency bins on the various outputs by computer
- For 5725~5850MHz: Directional gain = 2.56dBi + 10\*log (2) = 5.57dBi < 6dBi, so the power density limit no need to reduce.

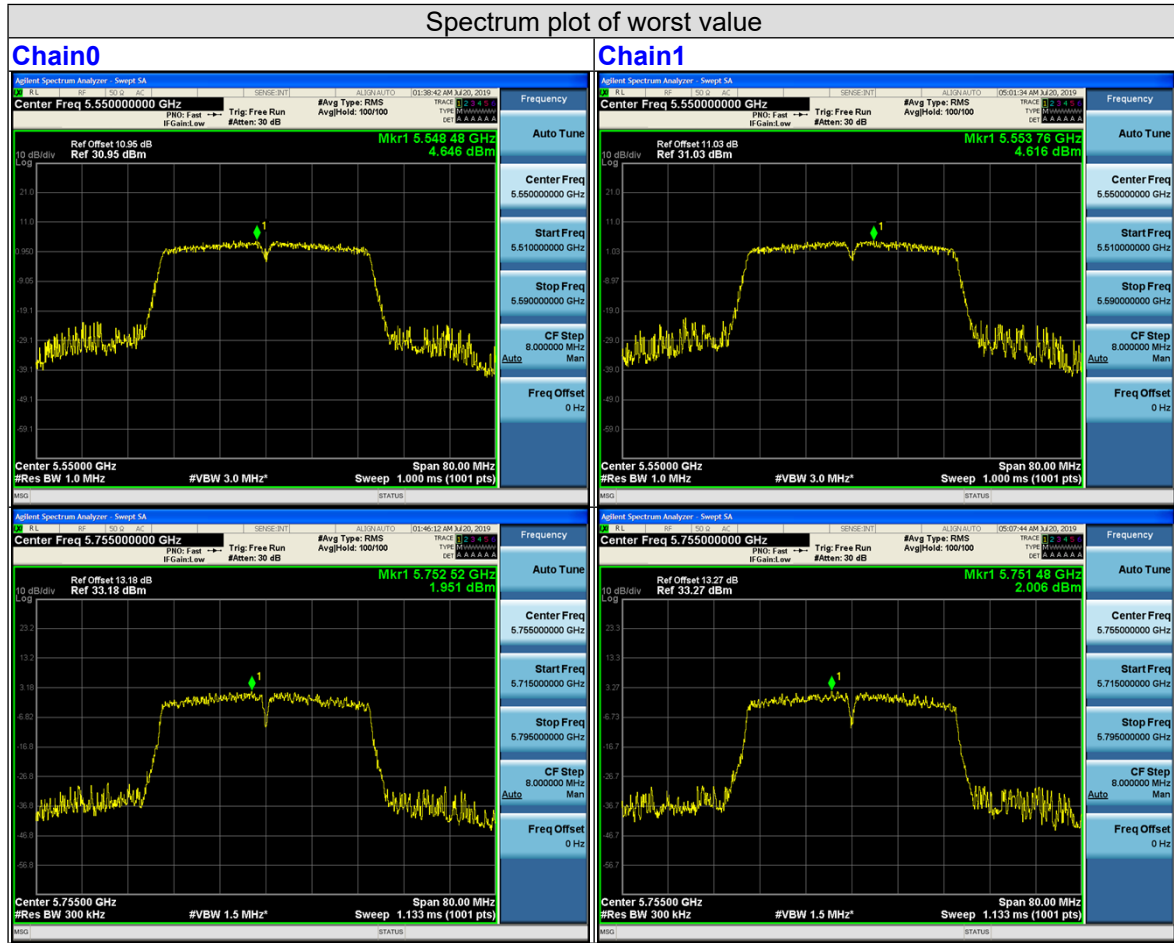

**802.11ac (80MHz)**

Channel Number	Frequency (MHz)	RF Power Level in 1MHz BW (dBm)		Total power density (mW)		Total power density		Total power add dutycycle factor(dBm)	Limit (dBm)
		Chain 0	Chain 1	Chain 0	Chain 1	mW	dBm		
42	5210	0.08	0.18	1.0186	1.0423	2.0609	3.14	3.95	10.01
58	5290	<b>1.69</b>	<b>1.01</b>	1.4757	1.2618	2.7375	4.37	5.18	10.18
106	5530	0.32	0.30	1.0765	1.0715	2.1480	3.32	4.13	10.49
122	5610	-0.02	0.77	1.0186	1.0423	2.0609	3.14	3.95	10.49

## Note:

- Method 1 of power density measurement of KDB 662911 is using for calculating total power density. Total power density is summing entire spectra across ponding frequency bins on the various outputs by computer
- For 5150~5250MHz: Directional gain = 3.98dBi + 10\*log(2) = 6.99dBi < 6dBi, so the power density limit need to reduce 0.99dB.
- For 5250~5350MHz: Directional gain = 3.81dBi + 10\*log(2) = 6.82dBi < 6dBi, so the power density limit need to reduce 0.82dB.
- For 5470~5725MHz: Directional gain = 3.50dBi + 10\*log(2) = 6.51dBi < 6dBi, so the power density limit need to reduce 0.51dB.

Channel Number	Frequency (MHz)	RF Power Level in 300kHz BW (dBm)		RF Power Level in 500kHz BW (dBm)		Total PSD (dBm /500kHz)	Total power add dutycycle factor(dBm)	Limit (dBm)
		Chain 0	Chain 1	Chain 0	Chain 1			
155	5775	<b>-1.219</b>	<b>-1.916</b>	1.00	0.30	2.33	3.14	30.00

## Note:

- Method 1 of power density measurement of KDB 662911 is using for calculating total power density. Total power density is summing entire spectra across ponding frequency bins on the various outputs by computer
- For 5725~5850MHz: Directional gain = 2.56dBi + 10\*log(2) = 5.57dBi < 6dBi, so the power density limit no need to reduce.

Spectrum plot of worst value

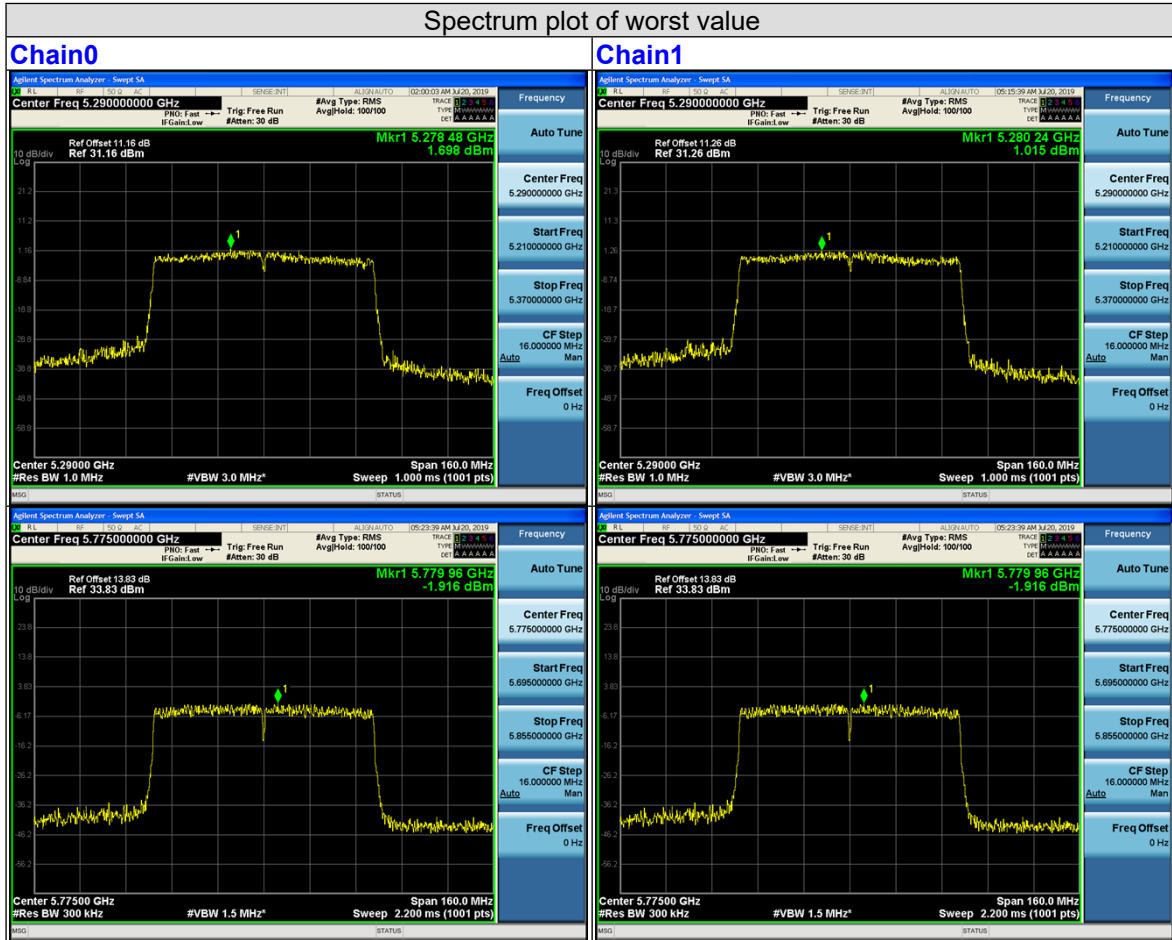

### 3.5 Frequency stability

#### 3.5.1 Limits of frequency stability measurement

The frequency of the carrier signal shall be maintained within band of operation.

#### 3.5.2 Test setup

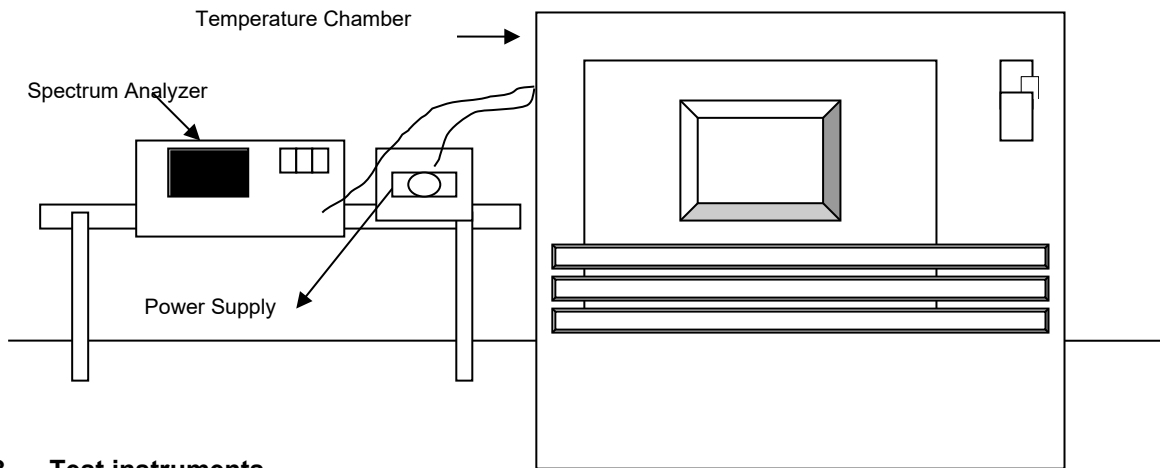

#### 3.5.3 Test instruments

Refer to section 3.3.3 to get information of above instrument.



#### 3.5.4 Test procedure

- a. The EUT was placed inside the environmental test chamber and powered by nominal AC voltage.
- b. Turn the EUT on and couple its output to a spectrum analyzer.
- c. Turn the EUT off and set the chamber to the highest temperature specified.
- d. Allow sufficient time (approximately 30 min) for the temperature of the chamber to stabilize, turn the EUT on and measure the operating frequency after 2, 5, and 10 minutes.
- e. Repeat step 2 and 3 with the temperature chamber set to the lowest temperature.
- f. The test chamber was allowed to stabilize at +20 degree C for a minimum of 30 minutes. The supply voltage was then adjusted on the EUT from 85% to 115% and the frequency record.

#### 3.5.5 Deviation from test standard

No deviation.

#### 3.5.6 EUT operating condition

Set the EUT transmit at un-modulation mode to test frequency stability.

**3.5.7 Test results**

Frequency stability versus temp.									
Operating frequency: 5180MHz									
Temp. (°C)	Power supply (Vdc)	0 minute		2 minute		5 minute		10 minute	
		Measured Frequency (MHz)	Frequency Drift	Measured Frequency (MHz)	Frequency Drift	Measured Frequency (MHz)	Frequency Drift	Measured Frequency (MHz)	Frequency Drift
50	5	5179.9789	-0.00041	5179.9818	-0.00035	5179.9786	-0.00041	5179.9815	-0.00036
40	5	5179.9856	-0.00028	5179.9886	-0.00022	5179.9873	-0.00025	5179.9901	-0.00019
30	5	5180.0048	0.00009	5180.0028	0.00005	5180.0044	0.00008	5180.0047	0.00009
20	5	5179.9898	-0.00020	5179.9947	-0.00010	5179.9925	-0.00014	5179.9915	-0.00016
10	5	5179.9898	-0.00020	5179.9899	-0.00019	5179.9873	-0.00025	5179.9916	-0.00016
0	5	5180.0095	0.00018	5180.0129	0.00025	5180.0114	0.00022	5180.0111	0.00021
-10	5	5179.9775	-0.00043	5179.9766	-0.00045	5179.9762	-0.00046	5179.9791	-0.00040
-20	5	5180.0206	0.00040	5180.0216	0.00042	5180.0221	0.00043	5180.0189	0.00036
-30	5	5180.0186	0.00036	5180.0207	0.00040	5180.0222	0.00043	5180.0202	0.00039

Frequency stability versus temp.									
Operating frequency: 5180MHz									
Temp. (°C)	Power supply (Vdc)	0 minute		2 minute		5 minute		10 minute	
		Measured Frequency (MHz)	Frequency Drift	Measured Frequency (MHz)	Frequency Drift	Measured Frequency (MHz)	Frequency Drift	Measured Frequency (MHz)	Frequency Drift
20	5.5	5179.9895	-0.00020	5179.9941	-0.00011	5179.9923	-0.00015	5179.9909	-0.00018
	5	5179.9898	-0.00020	5179.9947	-0.00010	5179.9925	-0.00014	5179.9915	-0.00016
	4.5	5179.9905	-0.00018	5179.9944	-0.00011	5179.9921	-0.00015	5179.9915	-0.00016

Band 1:5150-5250MHz  
99% Occupied Bandwidth Without over DFS Band

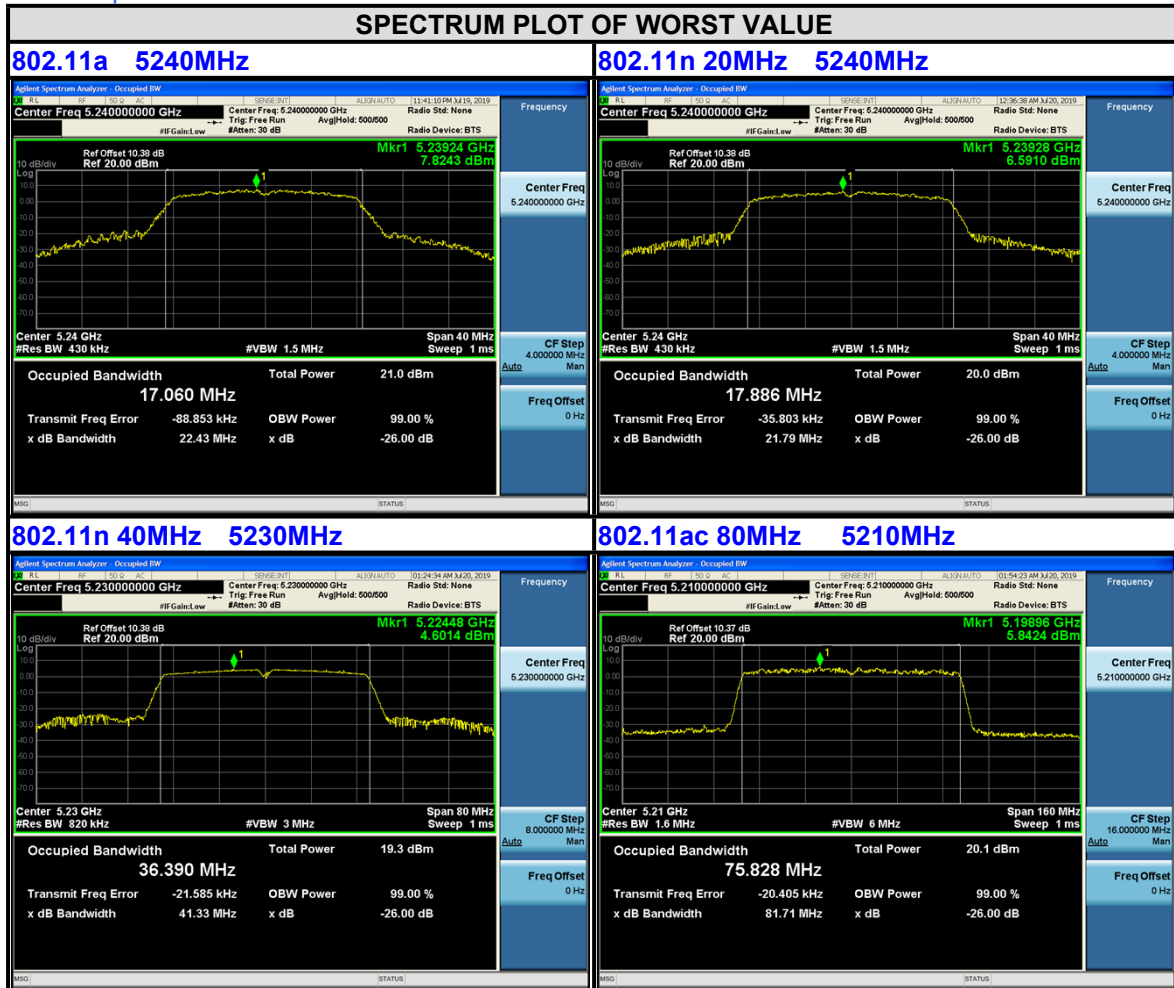

Band 2:5250-5350MHz  
99% Occupied Bandwidth Without over Band 1

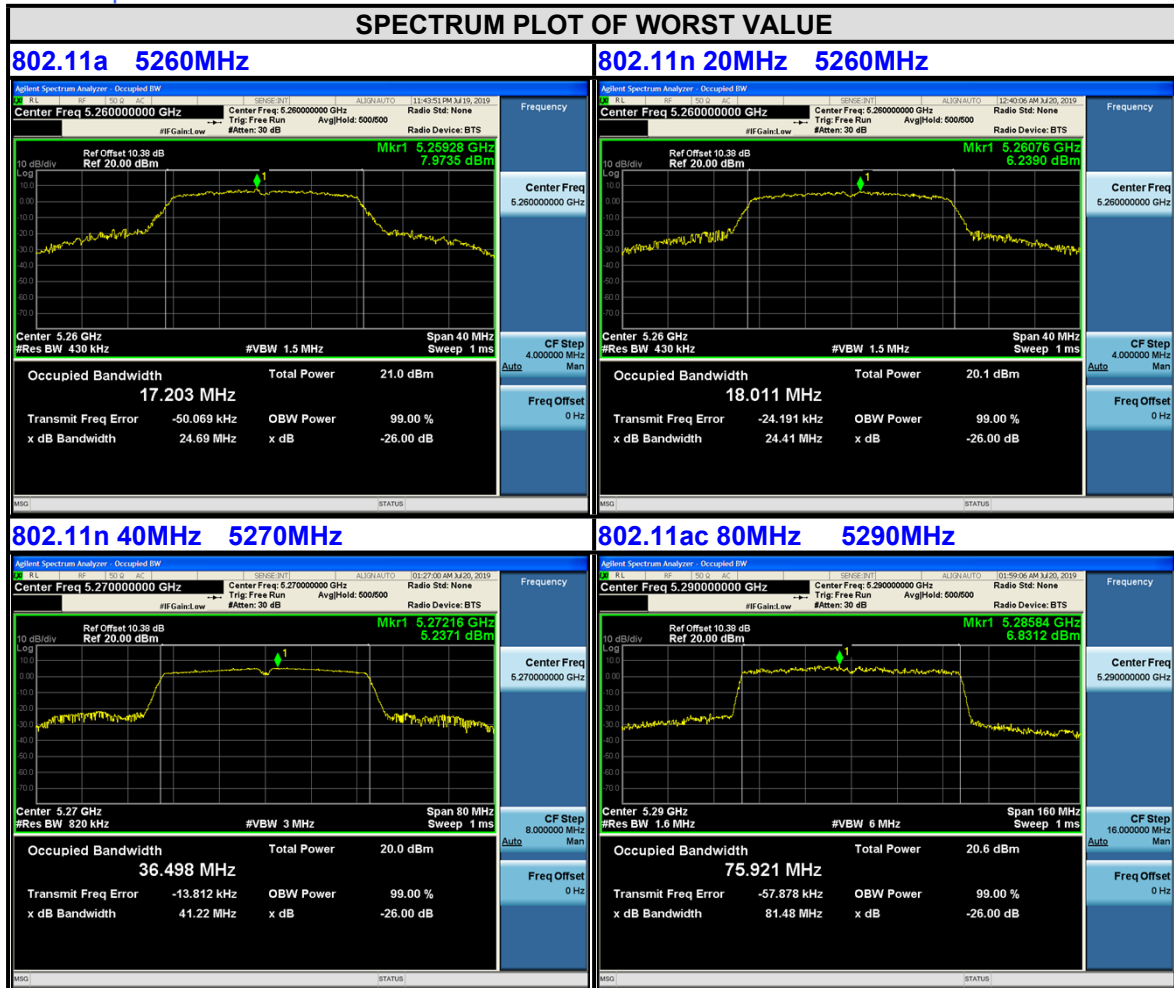

#### **4. Photographs of the test configuration**

Please refer to the attached file (Test Setup Photo).

**5. Appendix a – modifications recorders for engineering changes**

No modifications were made to the EUT by the lab during the test.

## 6. Appendix b – Information on the Testing Laboratories

We, [Hwa-Hsing \(Dongguan\) Co., Ltd.](#), A global provider of TESTING and CERTIFICATION services for consumer products, electronic products and wireless information technology products. Adhering to the core values “HONEST and TRUSTWORTHY, OBJECTIVE and IMPARTIALITY, RIGOROUS and AFFICIENT”, commitment to provide professional, perfect and efficient comprehensive ONE-STOP solution of TESTING and CERTIFICATION services for Manufacturers, Buyers, Traders, Brands, Retailers. Assist client to better manage risk, protect their brands, reduce costs and cut time to over 150 markets in global. Our laboratories are FCC recognized accredited test firms and accredited and approved according to ISO/IEC 17025.

If you have any comments, please feel free to contact us at the following:

Lab Address: [No.101, Bld N1, Yuyuan 2Rd, Yuyuan Industrial Park, HuangJiang Town, Dongguan, China](#)

Contact Tel: [0769-83078199](tel:0769-83078199)

Email: [customerservice.dg@hwa-hsing.com](mailto:customerservice.dg@hwa-hsing.com)

Web Site: [www.hwa-hsing.com](http://www.hwa-hsing.com)

---END---