



# **Collaboration Touch Screen User Manual**

Newline Interactive Inc.

[www.newline-interactive.com](http://www.newline-interactive.com)

---

Welcome to the world of TruTouch.

Thank you for choosing TruTouch Xseries Collaboration Touch Screen. Please use this document to maximize your user experience.

---

This device complies with part 15 of the FCC Rules. Operation is subject to the following two conditions: (1) This device may not cause harmful interference, and (2) this device must accept any interference received, including interference that may cause undesired operation.

NOTE 1: This equipment has been tested and found to comply with the limits for a Class B digital device, pursuant to part 15 of the FCC Rules. These limits are designed to provide reasonable protection against harmful interference in a residential installation. This equipment generates uses and can radiate radio frequency energy and, if not installed and used in accordance with the instructions, may cause harmful interference to radio communications. However, there is no guarantee that interference will not occur in a particular installation. If this equipment does cause harmful interference to radio or television reception, which can be determined by turning the equipment off and on, the user is encouraged to try to correct the interference by one or more of the following measures:

- Reorient or relocate the receiving antenna.
- Increase the separation between the equipment and receiver.
- Connect the equipment into an outlet on a circuit different from that to which the receiver is connected.
- Consult the dealer or an experienced radio/ TV technician for help.

NOTE 2: Any changes or modifications to this unit not expressly approved by the party responsible for compliance could void the user's authority to operate the equipment.

---

The symbol of the crossed out wheeled bin indicates this product should not be placed in municipal waste. Instead, you need to dispose of the waste equipment by handing it over to a designated collection point for the recycling of waste electrical and electronic equipment.



# Contents

---




<b>Safety Instruction</b> .....	<b>3</b>
<b>1 Overview</b> .....	<b>7</b>
1.1 Introduction .....	7
1.2 Parts .....	7
1.3 Ports .....	9
1.4 Remote Control.....	12
<b>2 Installation Guide</b> .....	<b>14</b>
2.1 Safety Precautions .....	14
2.2 Installation Precautions.....	15
2.3 Installation .....	16
<b>3 Getting Started</b> .....	<b>18</b>
3.1 Power On.....	18
3.2 Power Off .....	18
3.3 Positioning.....	20
<b>4 Operating the Touch Screen</b> .....	<b>23</b>
4.1 Home Page.....	23
4.2 Assistant Meeting.....	25
4.2.1 Newline Assistant .....	25
4.2.2 Switch Applications .....	25
4.2.3 Add or Delete Applications.....	25
4.3 Whiteboard .....	30
4.3.1 Whiteboard Functions.....	31
4.3.2 Slide Operations.....	36
4.4 Signal Source.....	37
4.5 External Storage.....	38
4.5.1 External Storage Page.....	38
4.5.2 File Preview .....	39
4.5.3 File Filtering .....	39
4.5.4 File Search .....	40
4.5.5 File Operations.....	41
4.6 End Meeting .....	42

4.6.1 Manually End Meeting .....	42
4.6.2 Automatically End Meeting .....	43
4.7 Shortcut Settings and Applications .....	44
4.7.1 Shortcut Settings .....	45
4.7.2 Applications .....	49
<b>5 Serial Port Control .....</b>	<b>50</b>
<b>6 Specifications .....</b>	<b>54</b>
<b>7 More Information.....</b>	<b>58</b>

## Safety Instruction

---

For your safety, please read the following instruction before you use the product. Serious injury or property loss may be caused by improper operations. Do not try to repair the product by your own.

 <b>WARNING</b>	
	<p><b>Disconnect the product from power supply immediately if major failures occur.</b></p> <p>The major failures include the following:</p> <ul style="list-style-type: none"> <li>• Smoke, peculiar smell or abnormal sound is discharged from the product.</li> <li>• No image or sound is displayed, or the image error occurs.</li> <li>• Where the mains plug or an appliance coupler is used as the disconnect device the disconnect device shall remain readily operable.</li> </ul> <p>In the preceding scenarios, do not continue to use the product, disconnect power supply immediately and contact professional staff for troubleshooting.</p>
	<p><b>Do not drop liquid, metal or combustible into the product.</b></p> <ul style="list-style-type: none"> <li>• If any liquid or metal is dropped into the product, power off the product and disconnect power supply, then contact professional staff for solutions.</li> <li>• Pay attention to the children when they are close to the product.</li> </ul> <p><b>Do not damage the power cable.</b></p> <ul style="list-style-type: none"> <li>• Do not damage, change, wind, bend, heat or drag the power cable forcibly.</li> <li>• Do not put weights (such as the product itself) on the power cable.</li> <li>• Do not drag the cable forcibly when you pull out the power plug. If the power cable is damaged, please contact the local distributor to repair or replace it.</li> <li>• The power cable in the accessory box is for this product only. Don't use it on other devices.</li> </ul>



## WARNING

### **Put the product on a stable surface.**

An unstable surface includes and does not limited to an inclined plane, a shaky stand, desk or platform, which might cause the turnover and damage.

### **Use the battery correctly.**

- Galvanic corrosion, electric leakage and even fire may be caused by improper battery usage.
- It is recommended to use the designated type of battery and install the battery by correct electrodes (positive and negative electrodes).
- Do not install and use new battery with the used one.
- Take out the battery if the remote control is not used for a long period.
- Do not expose the battery under overheated environments such as sunlight and firing.
- Dump the used battery based on local regulations.



### **Do not open the cover or change the product by your own.**

High voltage components are installed in the product. When you open the cover, high voltage, electric shock or other dangerous situations may occur. If inspection, adjustment or maintenance is required, contact the local distributor for help.



### **Use the specified power supply.**

- Do not use any types of power cables other than the one provided with the product to prevent the product from being damaged.
- Use a three-wire socket and ensure that it is properly grounded.
- Pull out the power plug from the socket if the product is not used for a long period.

### **Before you move the product, disconnect all external connections and separate all toppling preventing devices.**

Move the product carefully to prevent it from being hit or squeezed, especially the screen, which may cause injury if broken.

### **Clean the dust and metal on the power plug regularly.**

- When you are cleaning, fire or electric shock may be caused if the product is powered on.
- Keep in mind to pull out the power plug before cleaning it by using a dried cloth.



### **Do not put items on the top of the product.**

- Do not put items, such as a container for liquid (a vase, flowerpot, cosmetics or liquid medicine), on the top of the product.
- If any water or liquid is spilled on the product, short circuit may occur and cause fire or electric shock.
- Do not tread on the product or hang any items on the product.



### **Do not install the product in an improper place.**

- Do not install the product in humid places, such as the bathroom, the shower room, the place near windows or outdoor environments where experience rain, snow or other harsh weather. The product installation is also required to avoid a place around by hot spring vapor. The preceding environments may cause faults or electric shock under extreme conditions.
- Do not put exposed fire source, such as an ignited candle, on the product.



## WARNING



### **Pull out the power plug during thunderstorms.**

- Do not touch the product when lighting to avoid electric shock.
- Install or place components which power supply voltage is high enough to cause personal injury in places out of the reach of children.



### **Do not cover or block up any vents on the product.**

- The overheated components may cause fire, damage the product and shorten the service life.
- Do not put the venting surface of the product facedown.
- Do not install the product on a carpet or bed clothes.
- Do not use a cloth such as table cloth to cover the product.



Do not touch the power cable with wet hands to avoid electric shock.



## CAUTION



### **Do not install the product in high temperature environments.**

- Do not install the product near heat source, such as the radiator, the heat reservoir, the stove or other heating devices.
- Do not expose the product under sunlight, which may cause high temperature and subsequent faults in the product.



### **For transport:**

- Pack the product for mobility or maintenance by using the cartons and cushioning material provided with the product.
- Vertically move the product during transport. The screen or other components are easily broken if the product is moved by an improper way.



### **Keep away from the product when you use a radio.**

The product design to prevent radio interference complies with the international EMI standard. However, the interference still exists and causes noise in the radio.

- If noise occurs in the radio, try the following solutions.
- Adjust the direction of the radio antenna to avoid the interference from the product.
- Keep the radio away from the product.

**Advice for watching:**

- Use the product in an environment with comfortable light. It is harmful to your eyes to watch in a too bright or too dark environment.
- Relax your eyes after a period of time for watching.
- When you are watching, the distance which is 3 to 7 times of the screen height should be kept, and it is the best distance to protect eyes and prevent eyestrain.
- Adjust the volume to an appropriate level, especially at night.
- Use amplifier equipment as the audio input source with caution. If you must use amplifier equipment, the input power should not exceed the maximum of speaker power. Otherwise, problems occur, such as the speaker is overpowered and damaged.

# 1 Overview

---

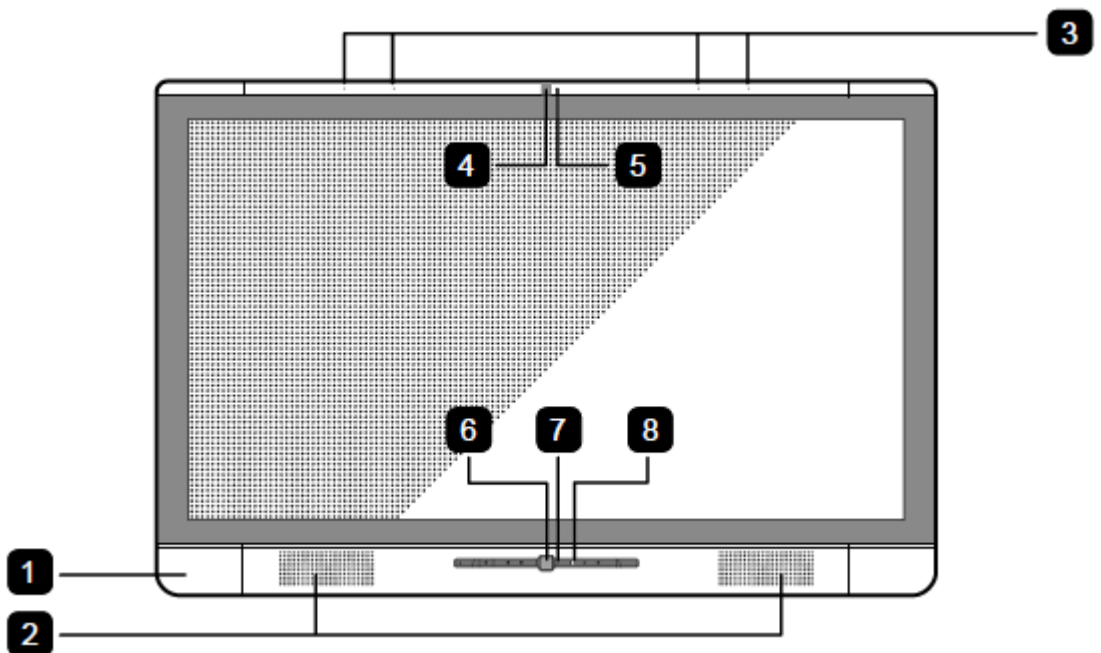
## 1.1 Introduction

The Collaboration Touch Screen adopts the advanced capacitive touch technology and All in One design, and integrates video, audio, touch, writing, and multi-media presentation functions. This product does not need additional devices, installation and wiring, and commissioning and maintenance.

Dedicated software is customized for the assistant meeting. It can meet requirements of various meeting modes, implementing convenient comments on local documents, viewing multi-media files, conducting multiparty remote video and audio meetings, managing local files, and improving meeting experience and work efficiency.

## 1.2 Parts

### Front Elevation



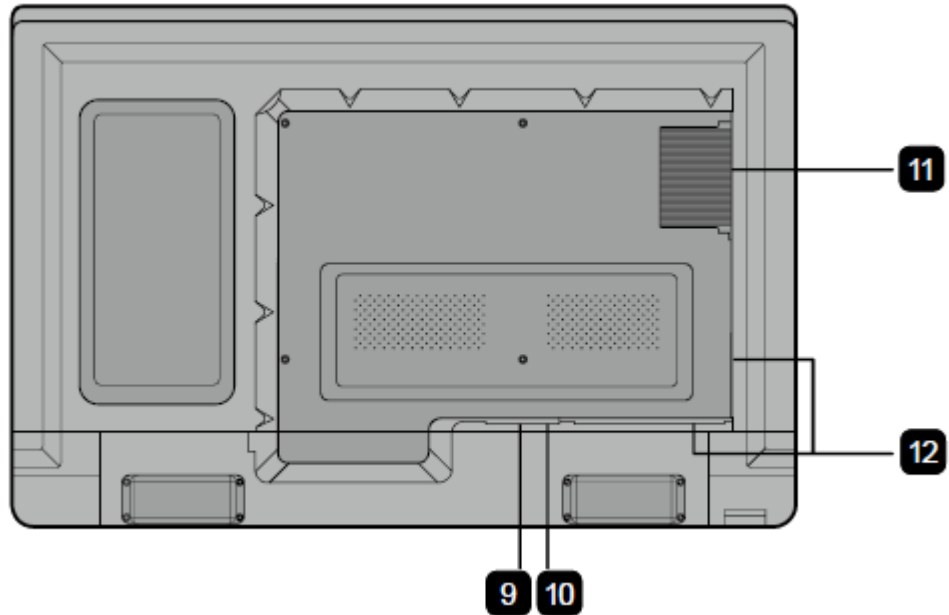




**NOTE**

- The top and bottom cameras cannot be used at the same time.
- The indicators of the top and bottom cameras are turning white when in use and off when not in use.

## Rear Elevation



**1** Front Ports

**2** Speakers

**3** Microphone Array

**4** Top Camera

**5** Camera Indicator

**6** Bottom Camera

**7** Camera Indicator

**8** Front Buttons

**9** General Power Switch

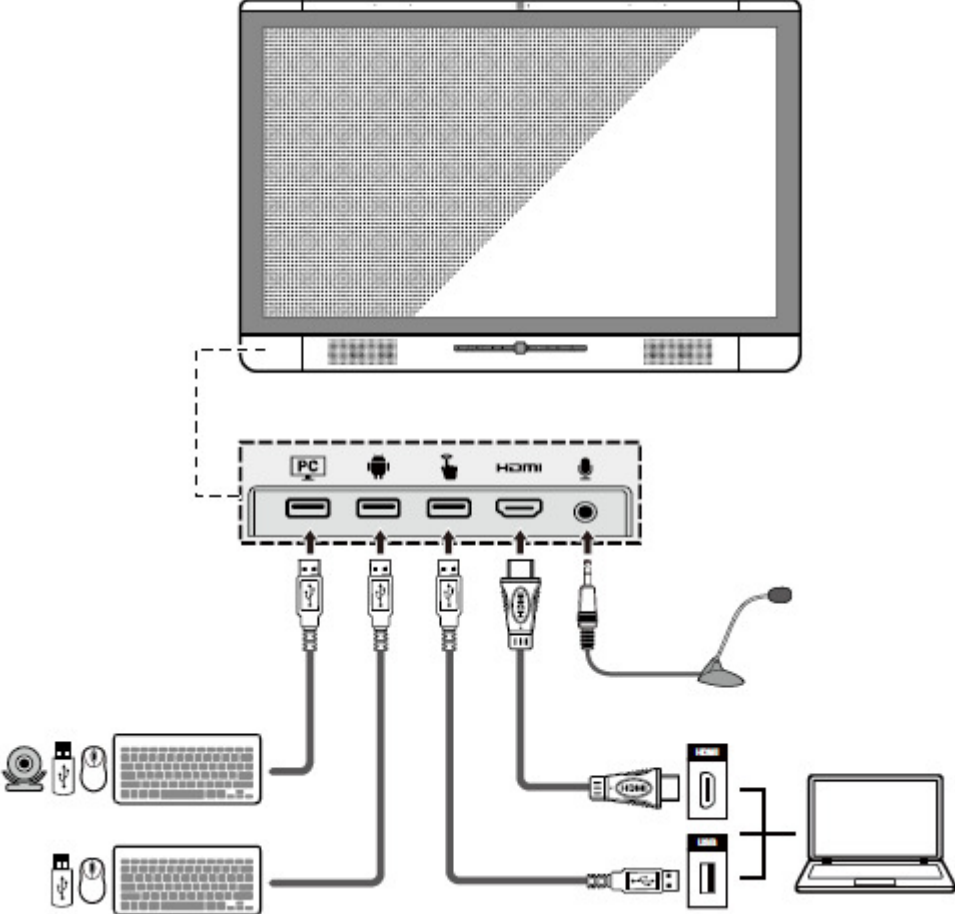
**10** AC Power

**11** Internal PC

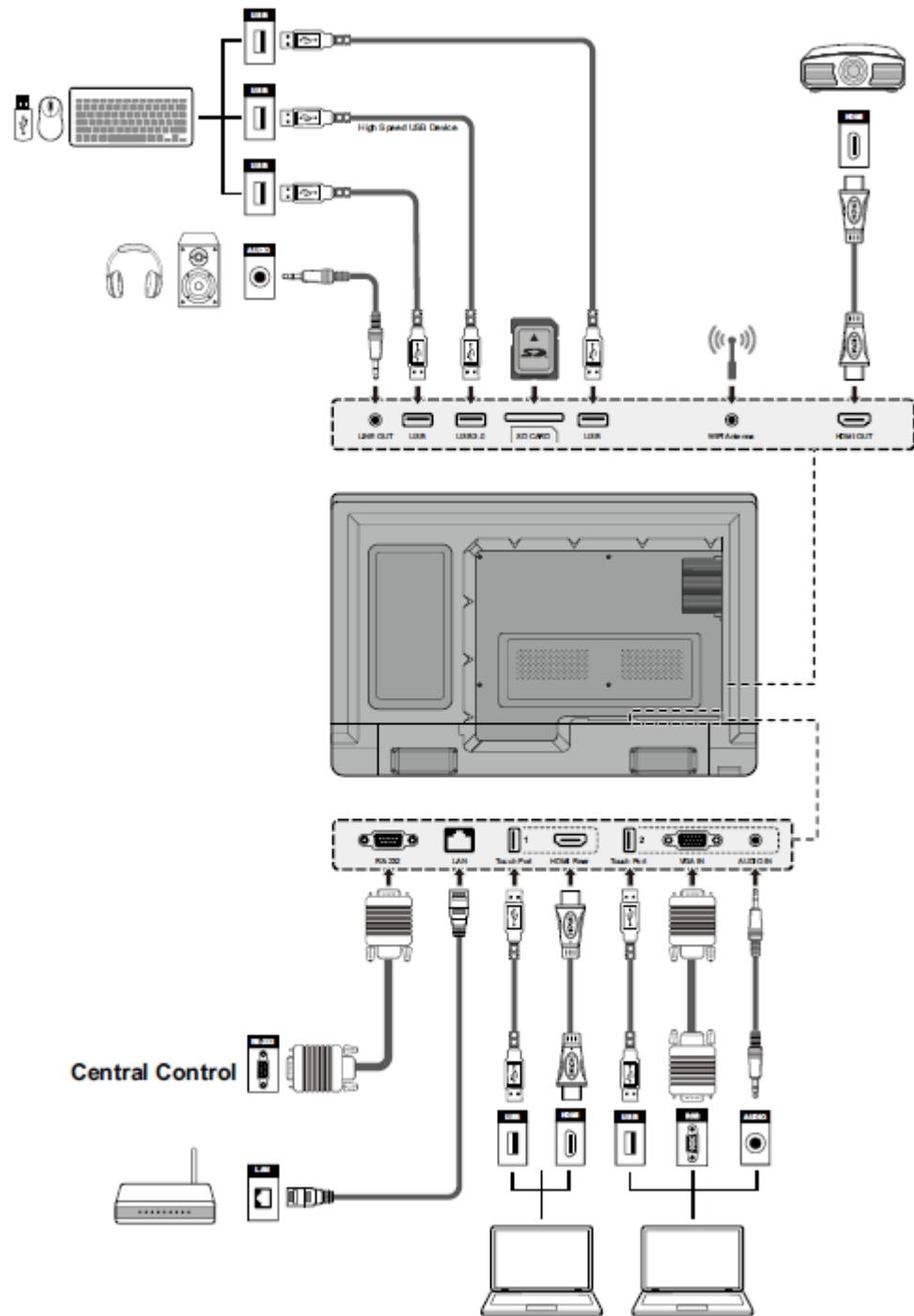
**12** Ports in the Back Panel

# 1.3 Ports

## Front Ports









## Rear Ports



## Front Buttons
















<b>Buttons</b>	<b>Operations</b>	<b>Functions</b>
	Short press	Power on/off
	Short press	Decrease volume
	Long press for more than 1 second	Decrease volume continuously
	Short press	Increase volume
	Long press for more than 1 second	Increase volume continuously
	Short press	Open the menu
	Short press	Return to the last menu/Exit
	Short press	Go to the home page

## 1.4 Remote Control



Buttons	Functions
	Power On/Off
<b>UC</b>	Start the Default UC Programs
	Mute
	Microphone Mute
	Up/Down/Left/Right
<b>OK</b>	Confirm/OK

Buttons	Functions
	Return to Previous/Exit
	Go to the Home Page
	Open the Menu
	Switch to Top Camera
	Switch to Bottom Camera
	Increase Volume
	Decrease Volume
	Settings
<b>Front</b>	Switch Source to HDMI Front
<b>Rear</b>	Switch Source to HDMI Rear
<b>VGA</b>	Switch Source to VGA
<b>PC</b>	Switch Source to Internal PC
	Page Up
	Page Down
	Toggle Display Mode
	Zoom Out (PC)
	Zoom In (PC)

# 2 Installation Guide

---

## 2.1 Safety Precautions

### Installation Environment



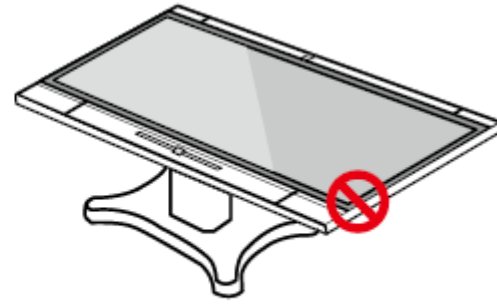
## Installation Direction



Hang the Unit Horizontally

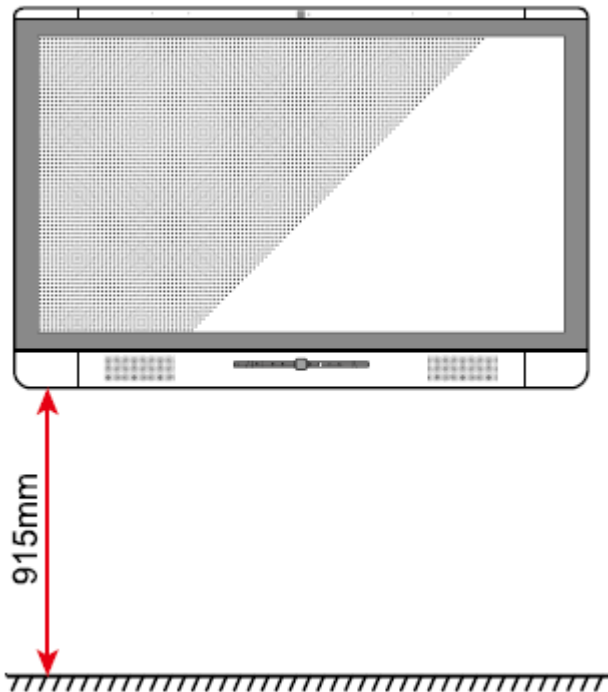


No Vertical Installation



Do Not Lie Down

## Installation Height



## 2.2 Installation Precautions

### Weight Loading

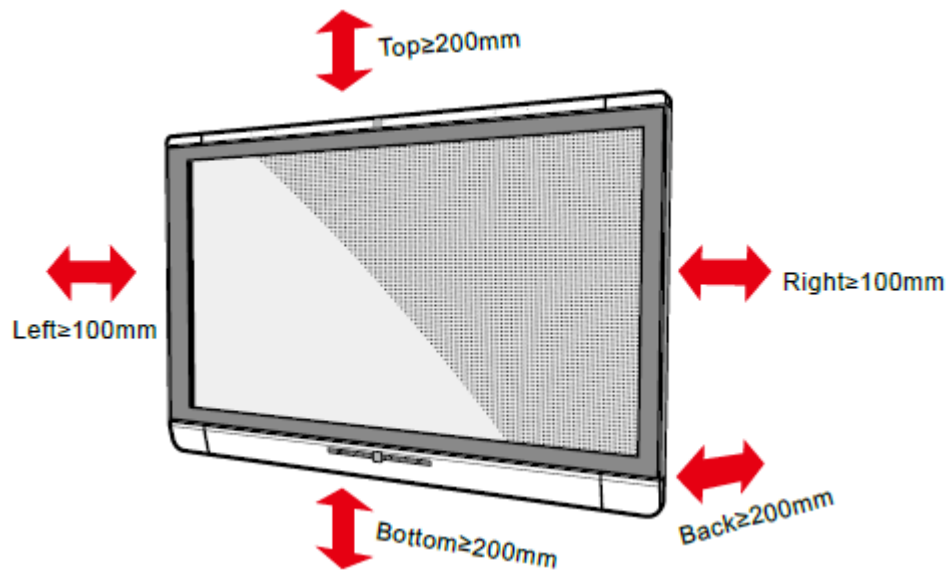
- The back of the panel is equipped with holes in VESA standard. Please use a VESA standard mounting system.
- When using a mobile cart, please ensure the mobile cart has no less than 60kg loading capacity.
- Weight of the unit: 79.4 lb/36kg



- When using wall-mount bracket, please ensure the wall can support the weight of the unit. We recommend that the wall surface is reinforced, and have a loading capacity twice the weight of the unit. Please consult a professional installer for wall-mount installation.
- Do not install the unit where it might be hit by a door.

## Ventilation

Ensure adequate ventilation and/or air conditioning environment. We recommend to keep certain distance from the side of the unit to the wall or panels. Ventilation requirement is showed in following figure.



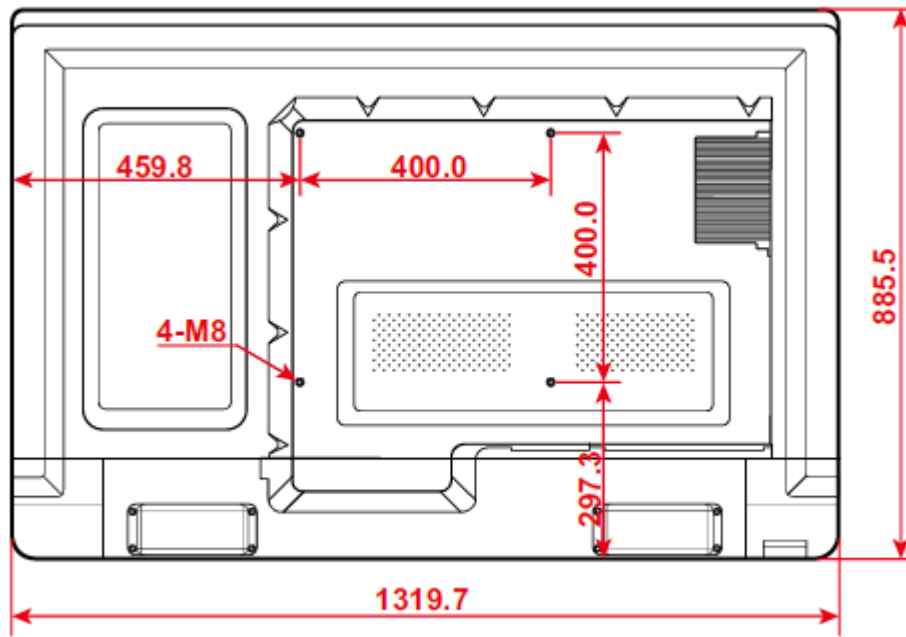
## 2.3 Installation

The dimensions of the 4 bracket mounting holes in the back panel is VESA MIS-F compliant (400 x 400mm). Please use the metric M8 screws with length of 10 to 15mm to secure the touch screen with the mounting system. Dimensions of the mounting holes in the back panel is shown in the following figure.



### NOTE

Please have a professional installer to install the display unit.



Unit: mm

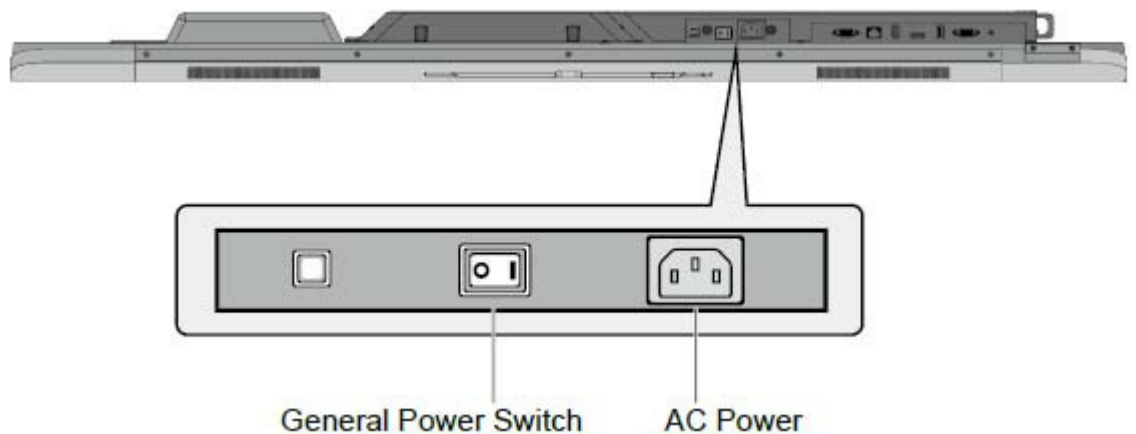
# 3 Getting Started

---



## 3.1 Power On

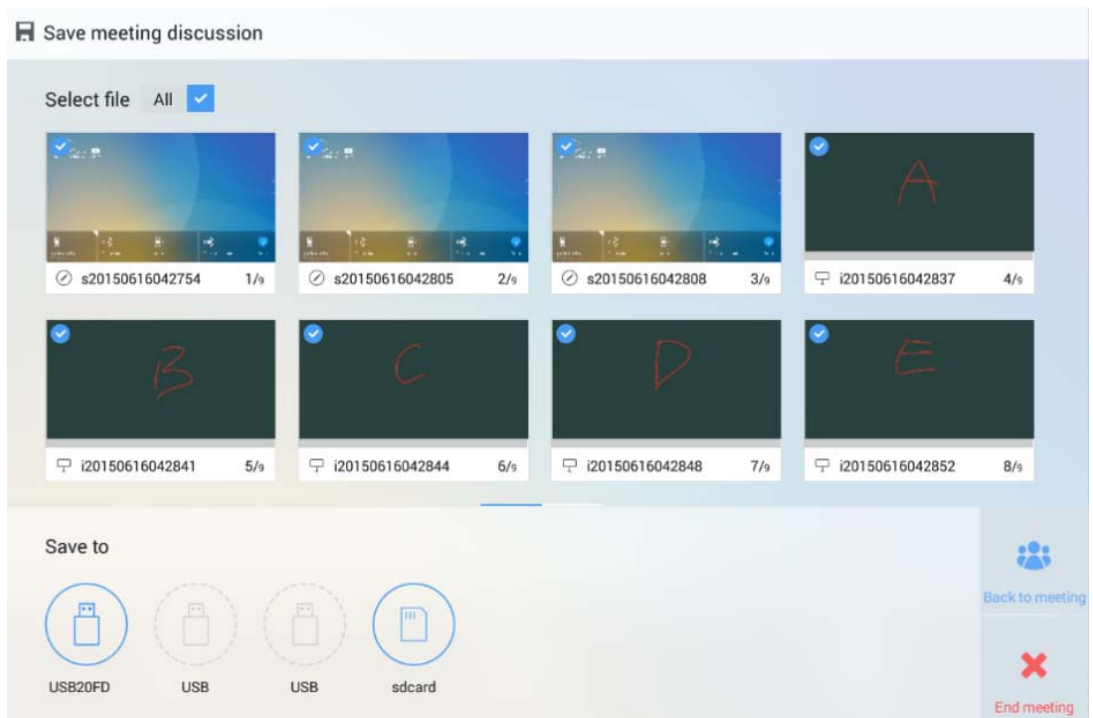
**Step 1** Plug in the power plug to the power outlet, and plug in the power connector to the side of the unit. Please ensure the power is in the range of 100V- 240V with frequency at 50Hz/60Hz  $\pm 5\%$ . The power current must be grounded.



**Step 2** Turn on the general power switch located on the side of the unit.

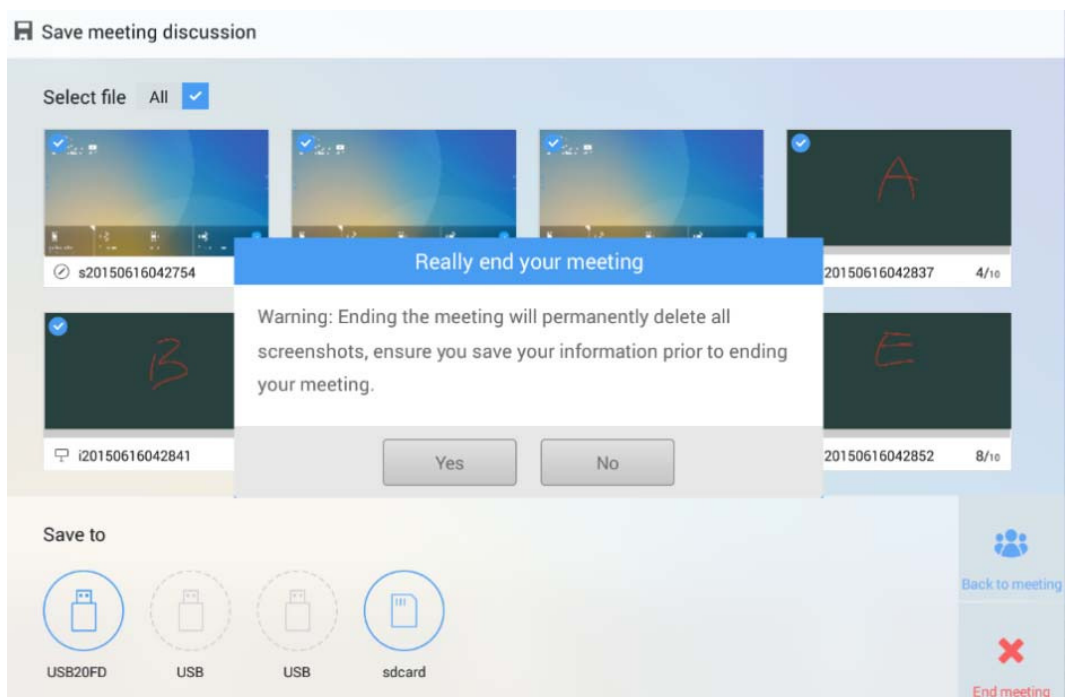


## 3.2 Power Off

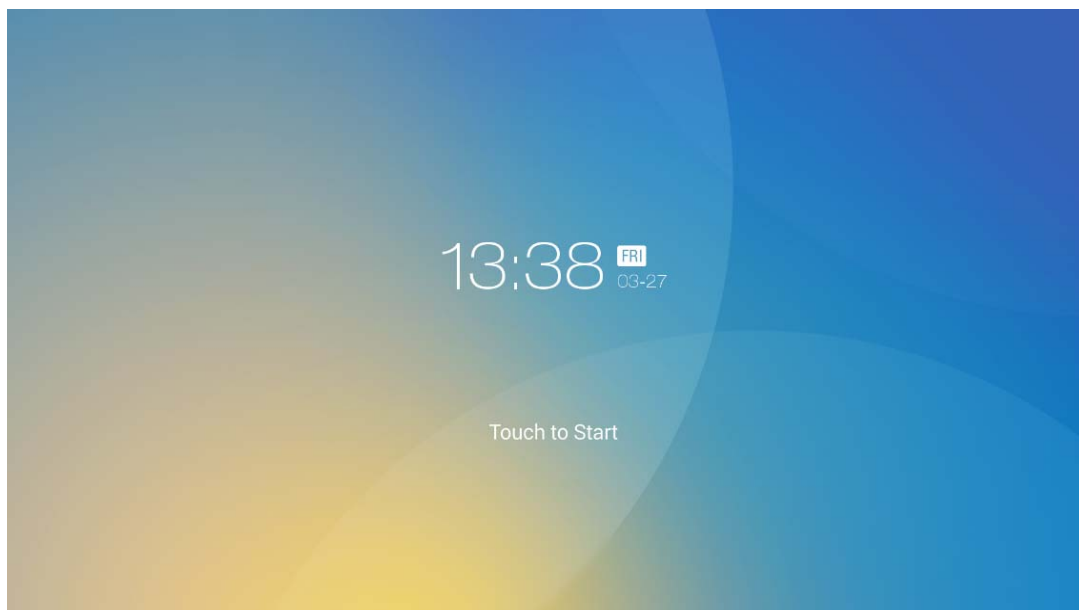
**Step 1** Press the power button  on the front panel or the power button  on the remote control. The **Save meeting discussion** page is displayed as follows.





**Step 2** Press the power button  on the front panel or the power button  on the remote control again. The **Really end your meeting** dialog box is displayed as follows.



**Step 3** In the **Really end your meeting** dialog box, click **Yes**. The meeting start page is displayed as follows.



- Step 4** Press the power button  on the front panel or the power button  on the remote control again to power off the panel. The power indicator turns off.
- Step 5** If you are not going to use the unit for an extended period of time, we recommend you to switch off the general power switch.

## 3.3 Positioning

If the cursor position has a big deviation from the actual touch point, calibration is used to eliminate the deviation. Positioning is required in the following scenarios:

- The computer with OPS inserted is used.
- The computer is connected through the HDMI or VGA interface.

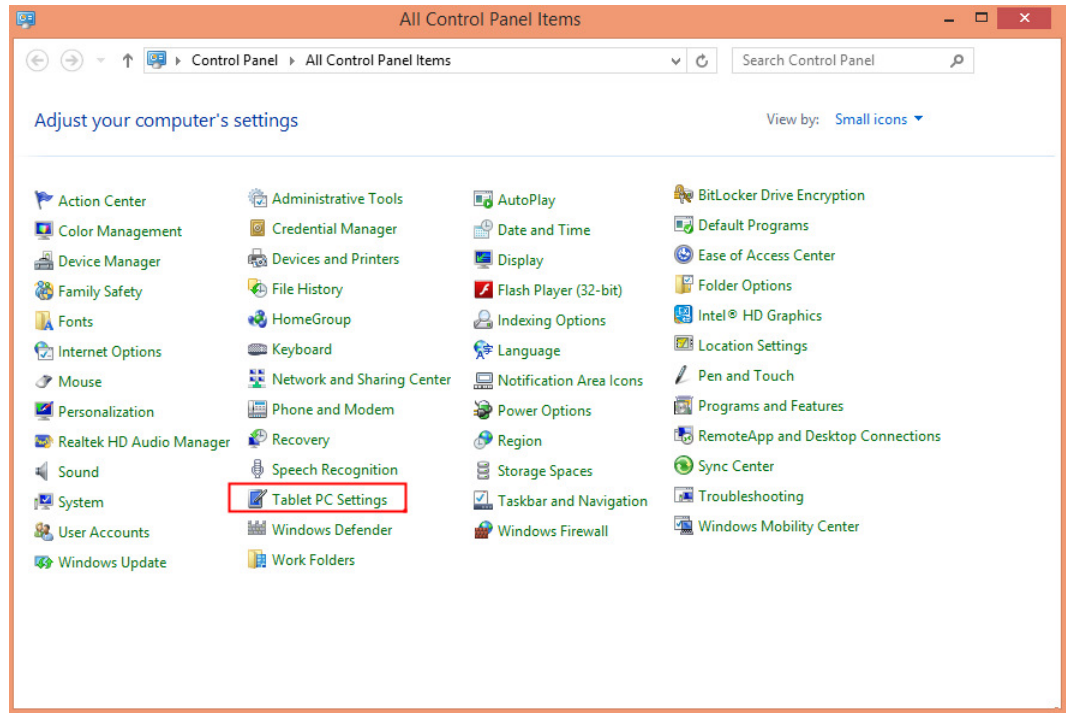


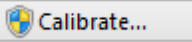
### NOTE

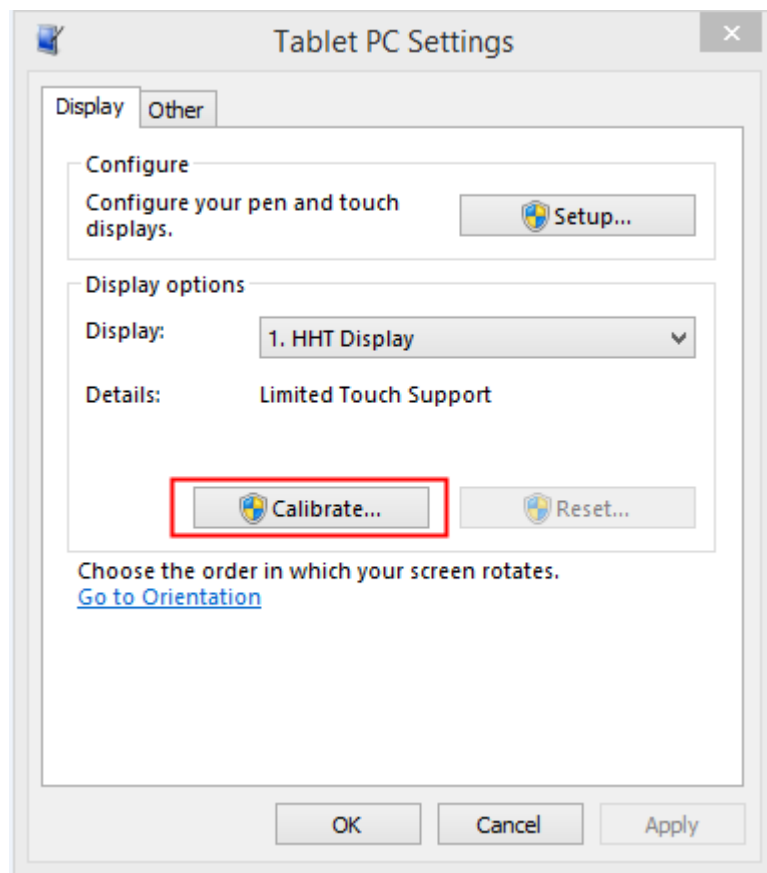
Interface operation on Android system does not need positioning. External devices with Microsoft Windows 7 or later versions require positioning.



If the positioning is not correct, perform the following operations to calibrate again:

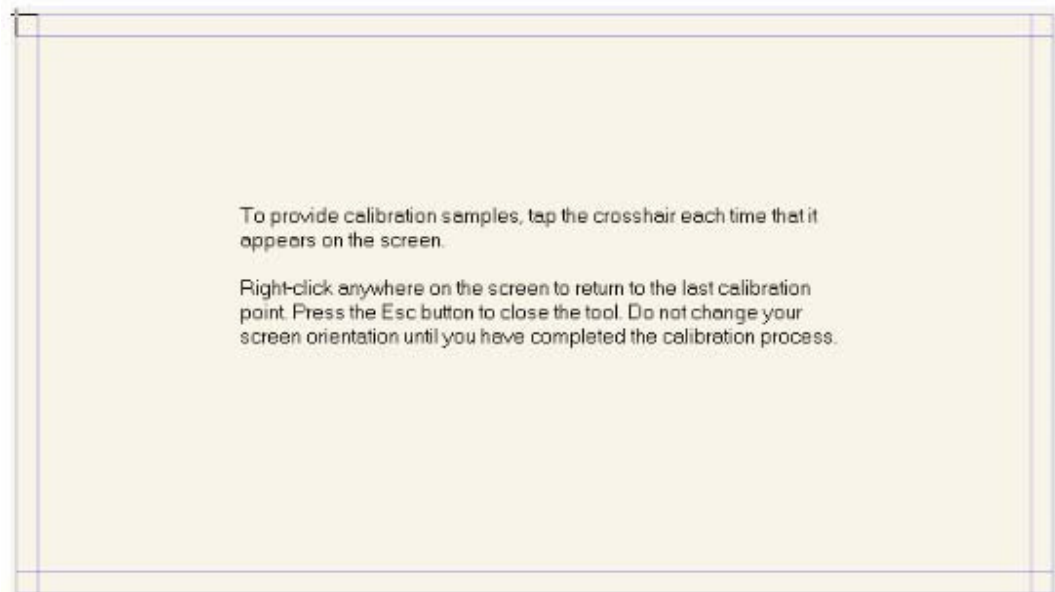
- Step 1** Ensure that the HDMI or VGA interface and external devices are connected properly.
- Step 2** Select the corresponding signal source on the signal source page. The Windows page is displayed.
- Step 3** Select **Tablet PC Settings** on the **Control Panel** page.



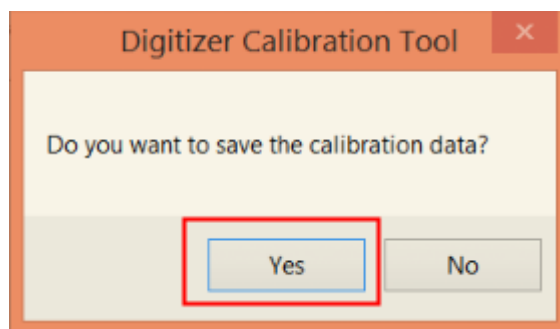
**Step 4** Select  in the **Tablet PC Settings** window.



**Step 5** Use finger or pencil to click and hold the center of the flickering crosshair . Do not release it until  moves to the next positioning point. Complete the calibration process as instructed.



**Step 6** After the calibration is complete, the **Digitizer Calibration Tool** dialog box is displayed. Click **Yes** to save calibration data.



 **TIP**

- To ensure writing accuracy, you are advised to use the pencil released with the product for positioning.
- Positioning errors may cause failure of touch functions of the display. In that case, please perform positioning again.

**Step 7** The **Tablet PC Settings** dialog box is displayed again. Click **OK**. The positioning is complete.

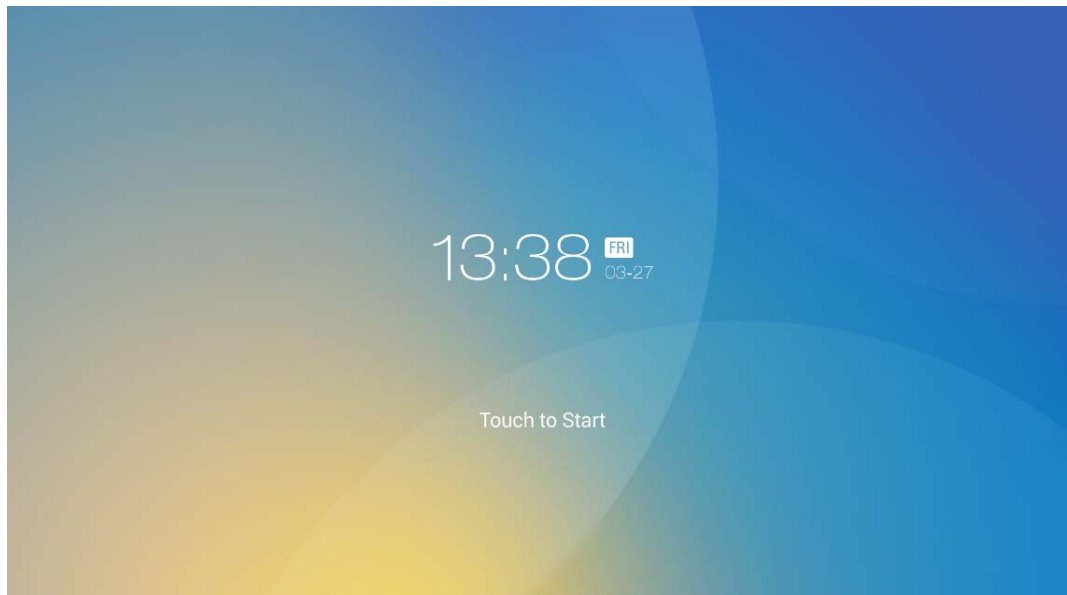
# 4 Operating the Touch Screen

---

## 4.1 Home Page

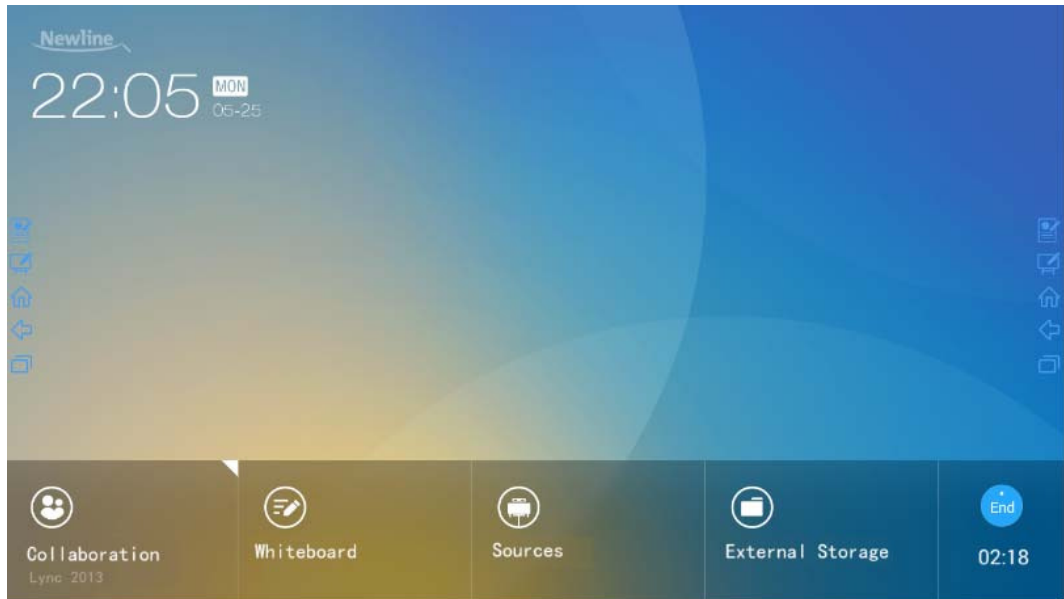
When the unit is turned on, it will show the **Meeting Start** page. The user can touch the screen to start a meeting, and the unit will go to the **Home** page. See the following figures.

**Figure 4-1** Meeting Start page





**Figure 4-2** Home Page



- **Collaboration**

The user can touch here to start the default UC programs, or touch the small triangle to set three shortcuts for frequently used UC programs. The default UC program is the one used last time.

- **Whiteboard**

The **Whiteboard** provides whiteboard and screen annotation functions.

- **Sources**

The user can select one of the four sources to display, including HDMI Front, HDMI Rear, Internal PC and VGA.






- **External Storage**

Open up the file manager to open files from external USB disk.

- **End**

Press **End** to end a meeting. Users will have the choice of saving the discussion boards screen captures and ending the meeting. Once a meeting is ended, all screenshots will be cleared.

Quick Access Buttons on Both Sides

-  : Click to start annotation, and click again to stop annotation and have screenshot.
-  : Start Whiteboard
-  : Go to Home Page
-  : Return to Previous App / Exit
-  : Switch Apps

## 4.2 Assistant Meeting

### 4.2.1 Newline Assistant

#### Introduction

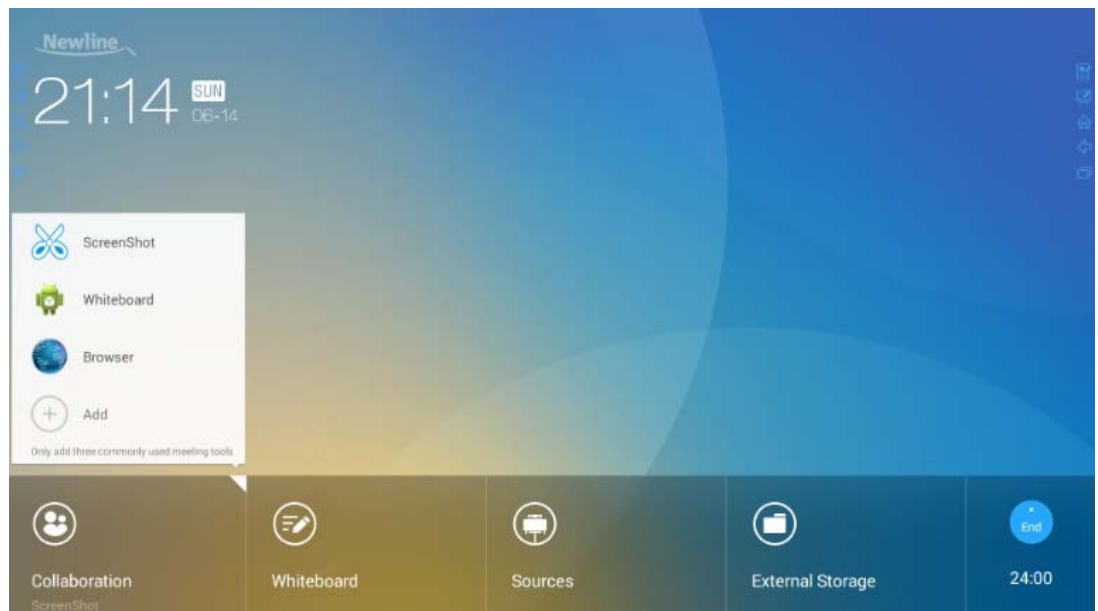
Newline Assistant is a tool used to obtain applications required by users on Windows system. On Android system, you can start Windows applications by clicking one button.

#### Installation

- Step 1** Connect Internal PC correctly.
- Step 2** On the home page, click **Sources**.
- Step 3** On the displayed signal source selection page, select **PC**. The Windows page is displayed.
- Step 4** Log in to the website [www.newline-interactive.com](http://www.newline-interactive.com) and choose **Products > Software** to download Newline Assistant installation package.
- Step 5** Install [Newline Assistant](#) as instructed.

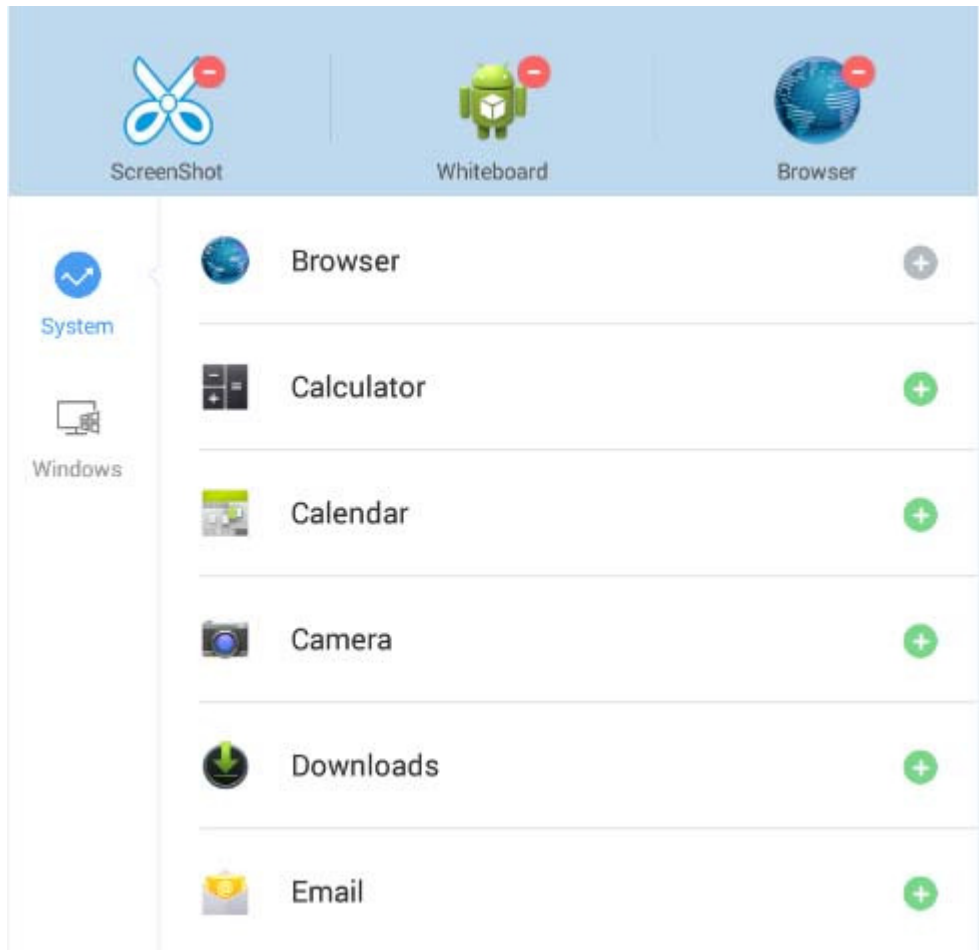
### 4.2.2 Switch Applications

On the home page, click **Collaboration** to start applications used last time, or click the triangle at the upper right corner of **Collaboration** to open the application list and select current applications to start the collaboration meeting. See the following figure.



### 4.2.3 Add or Delete Applications

To change meeting software, click the triangle at the upper right corner of **Collaboration**, click **Add** on the displayed menu, and add or delete applications on the application customization page. The following figure shows the application customization page.



**NOTE**

The **Windows** icon on the left navigation area is available only when the Collaboration Touch Screen has Internal PC.

## Add Applications on Android System

**Step 1** On the application customization page, click to view applications on Android system.

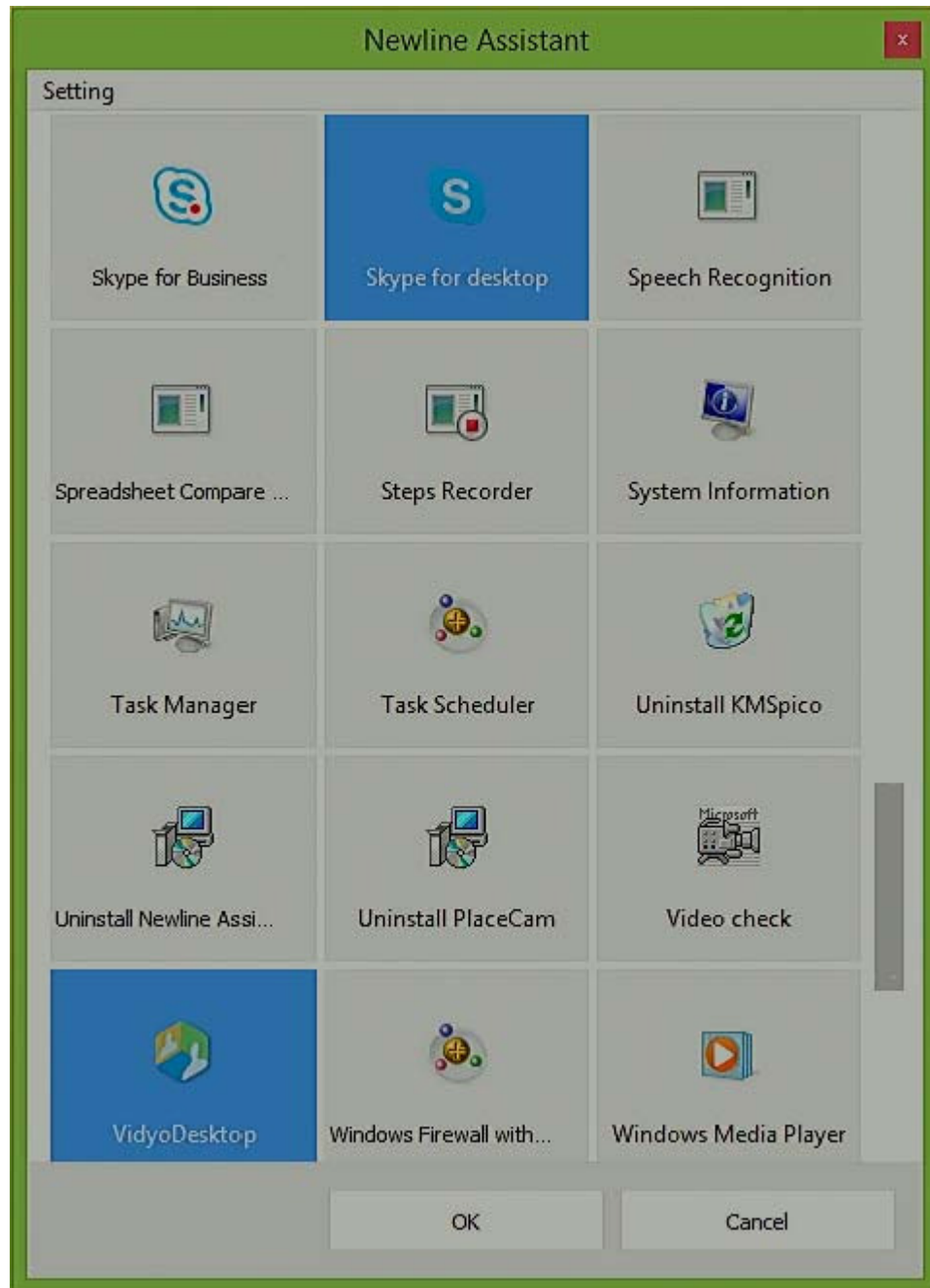
**Step 2** In the application list displayed on the right area, click on the right of an application to add the application.

A maximum of 3 applications can be added. is displayed on the right of an application that has been added.

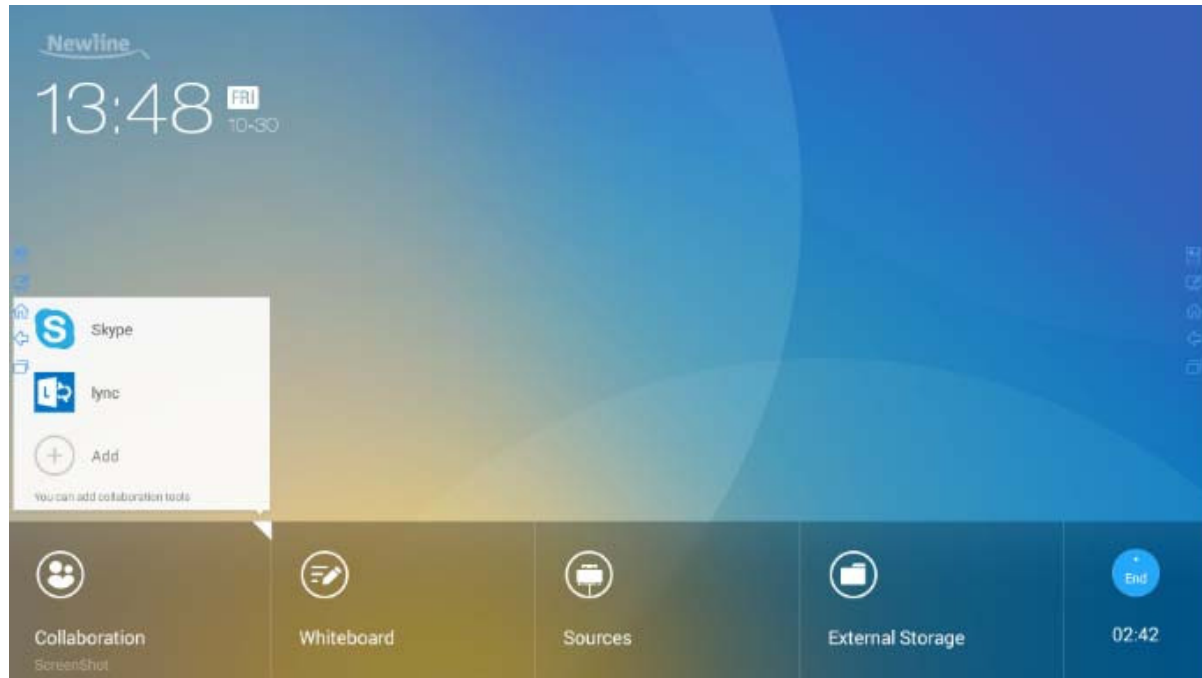
**Step 3** Return to the home page, click the triangle at the upper right corner of **Collaboration**, and click the added application on the displayed menu. After the application is started once, its name will be added to the lower area of the **Collaboration** button, and users can fast start the added application by only clicking **Collaboration**.


## Add Applications on Windows System

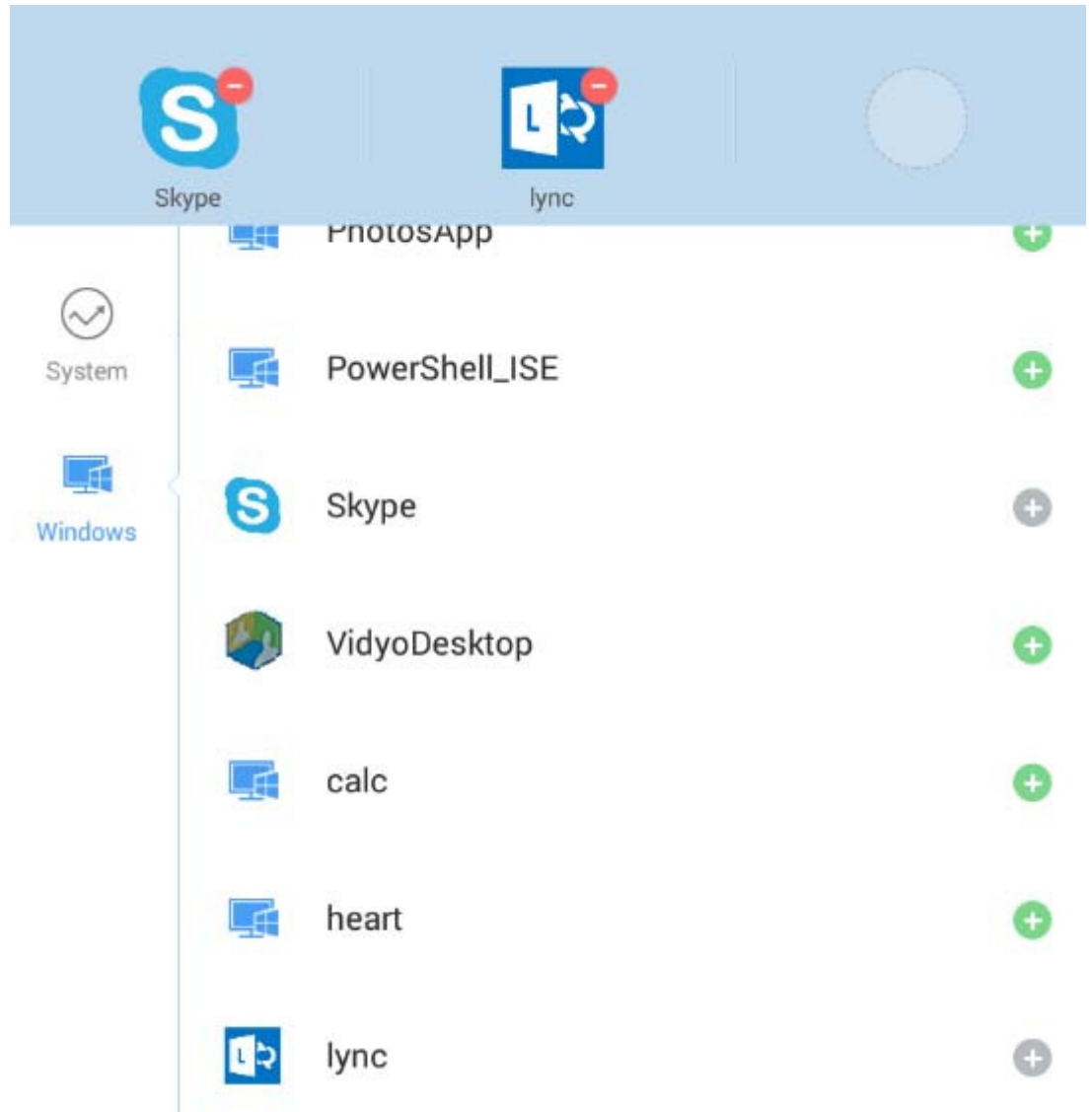
**Step 1** Run the Newline Assistant application on Windows system, and select applications to be added in the displayed **Newline Assistant** window.





**Step 2** Click  to return to the home page. Click the triangle at the upper right corner of **Collaboration** and select **Add** on the displayed menu. The customization page is displayed.



**Step 3** On the customization page, click  to view all Windows applications added using Newline Assistant in Step 1.






**Step 4** Add applications on the page described in Step 3.

In the application list displayed on the right area, click  on the right of an application to add the application. A maximum of 3 applications (including Android and Windows applications) can be added.  is displayed on the right of an application that has been added.

**Step 5** Return to the home page, click the triangle at the upper right corner of **Collaboration**, and click the added application on the displayed menu. After the application is started once, its name will be added to the lower area of the **Collaboration** button, and users can fast start the added Windows application by only clicking **Collaboration**.

## Delete Applications




On the application customization page, click  at the upper right corner of an application to delete the application. After an application is deleted successfully,  restores to .

## 4.3 Whiteboard

- Writing or Annotation  
On the whiteboard page, you can select pen type, width, and color to write or annotate. Also erase selected content or clear all contents.
- File management  
Preview, select, copy or delete a file.

To access the whiteboard meeting, click **Whiteboard**. See the following figure.




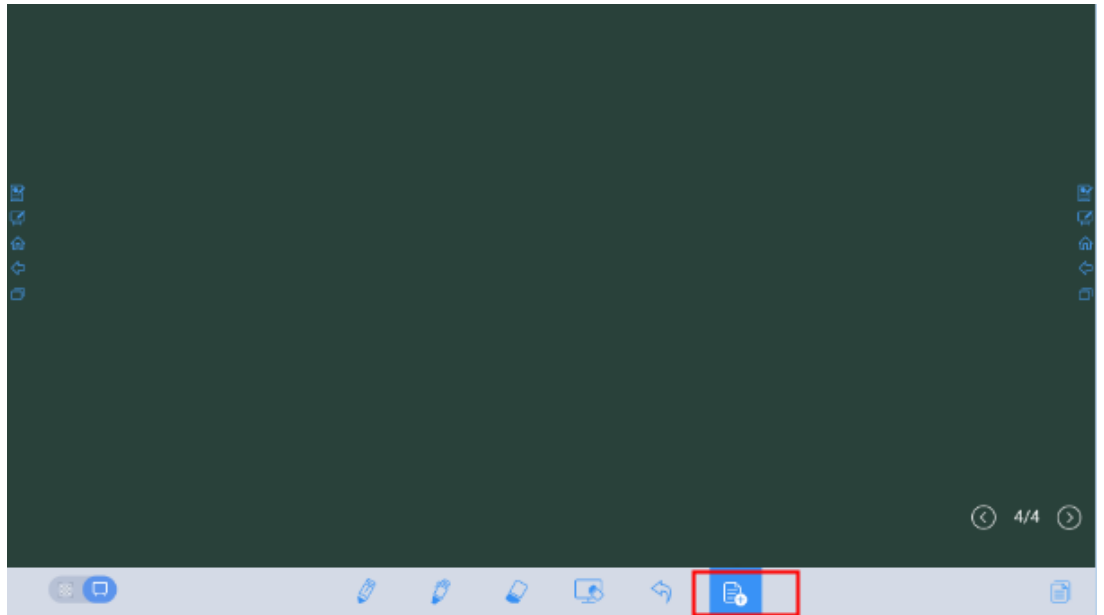
SN	Icon Name
1	Switch between writing and annotation modes.
2	Hard pen
3	Highlighter
4	Eraser
5	Clear
6	Undo
7	<p>New slide</p> <p> <b>NOTE</b></p> <p>Only writing mode has this function. In annotation mode,  is replaced with  (screenshot). For details about writing and annotation modes, see section <b>Whiteboard Mode</b>.</p>

## 4.3.1 Whiteboard Functions


### New Slide and Settings

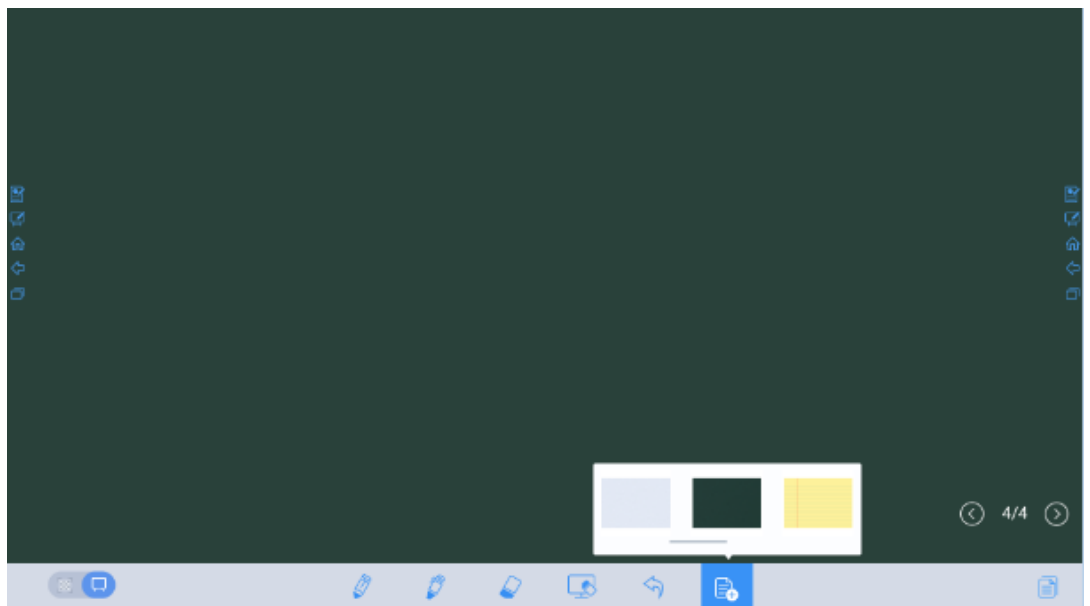
- Create a new slide

In writing mode, click  to create a new slide. A maximum of 20 slides can be created. See the following figure.





- Slide settings


Click and hold  to set the background color of new slides. See the following figure.



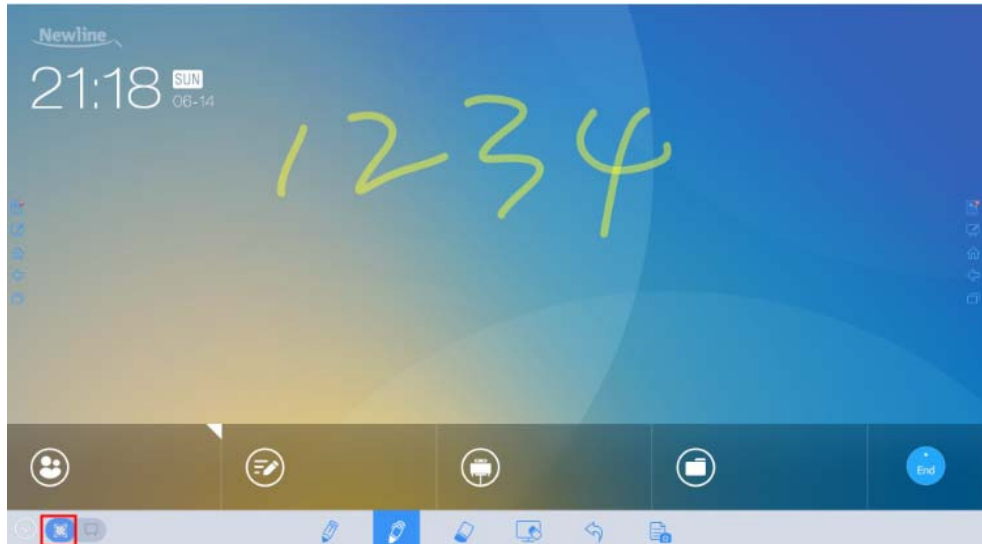



## Whiteboard Mode

Click  and  at the lower left corner of the whiteboard to switch whiteboard modes.

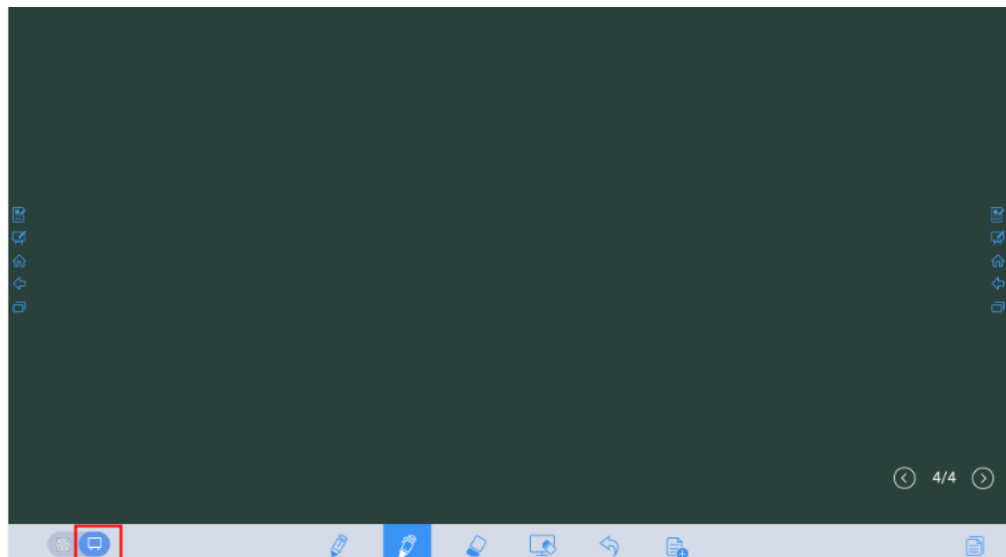
- : Annotation mode

The background is transparent and the real-time image of the current signal source is displayed. You can comment on presentation content such as Office documents and pictures as required. See the following figure.





- : Writing mode

The background is in mono color. You can write content as required. See the following figure.



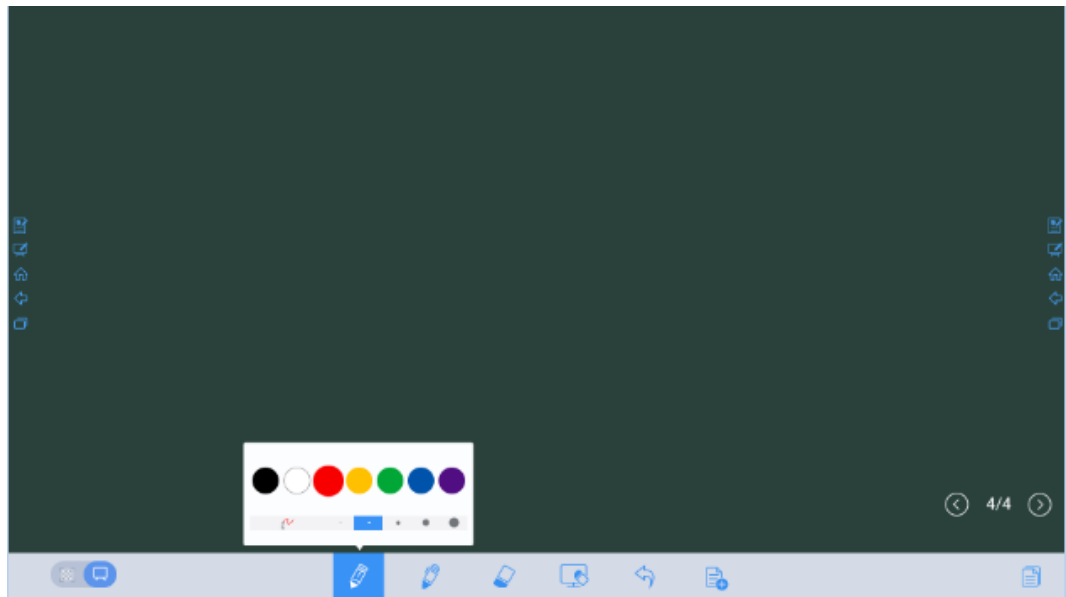
## Pen Type

On the whiteboard, two types of pens are supported: hard pen and highlighter. Their icons are  and .

- Hard pen: used to write.
- Highlighter: used to comment. Characters covered by comments are visible.



## Line Type and Color

On the whiteboard, click and hold  or . The line type and color selection page is displayed. You can select the line type and color for writing. See the following figure.




## Eraser

Two methods are available to erase written errors or content as follows:

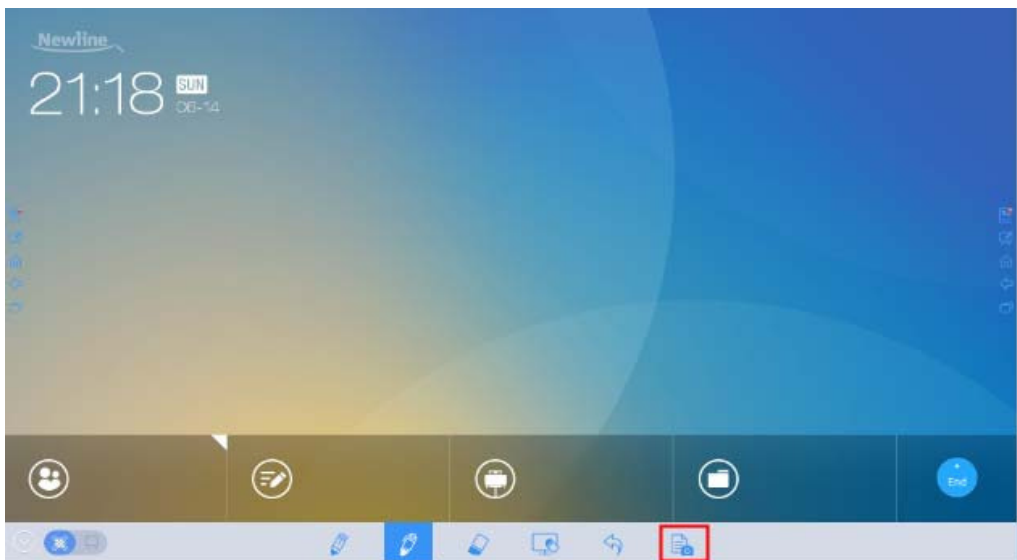
- Five-finger gesture: touch the screen with five fingers at the same time. A circle shows and indicates the area for eraser. Move the circle with fingers to erase written contents.
- Click  to clear wrong or unnecessary content. You can click and hold  to set the radius of the eraser. See the following figure.



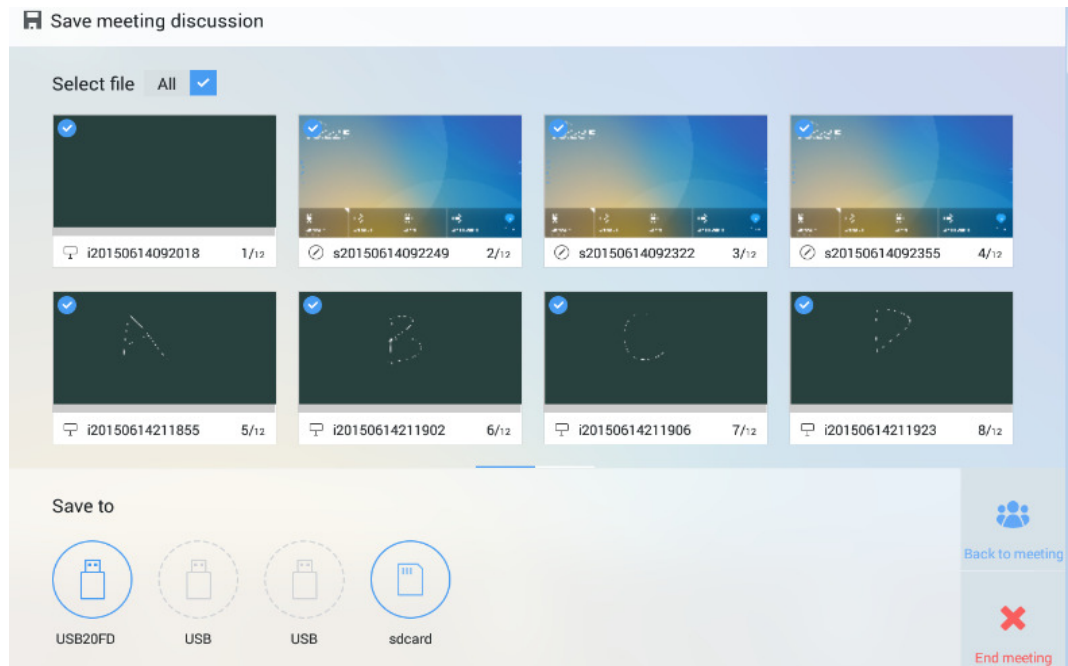
## Screenshot

In comment mode, click  to save the current image as a picture, as shown in Figure 4-3. After the meeting is ended, save screenshots in the **Save meeting discussion** dialog box, as shown in Figure 4-4.


**Figure 4-3** Screenshot

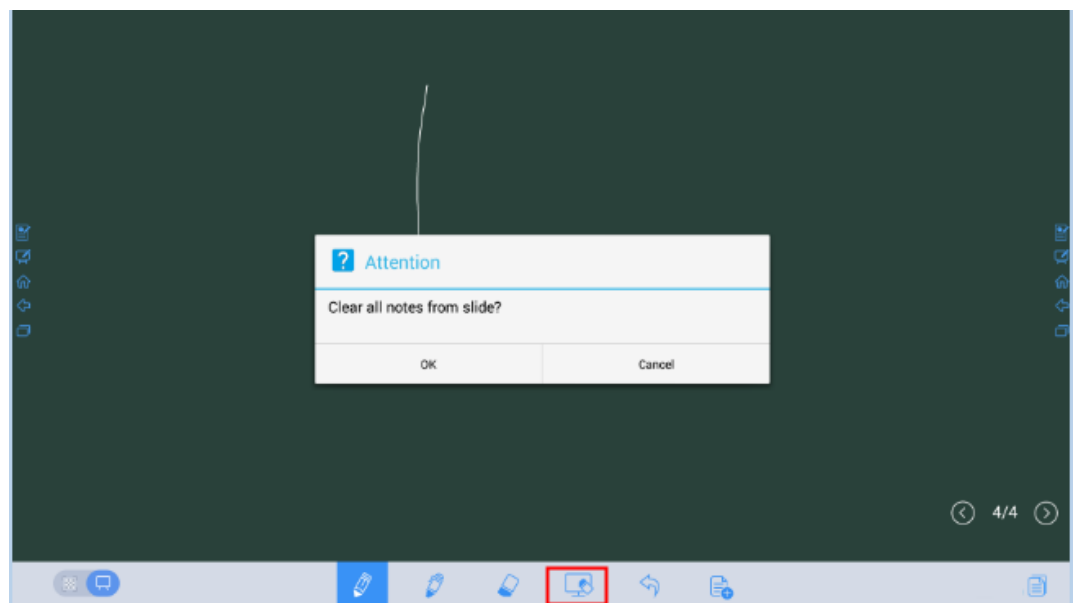


**Figure 4-4** Save meeting discussion




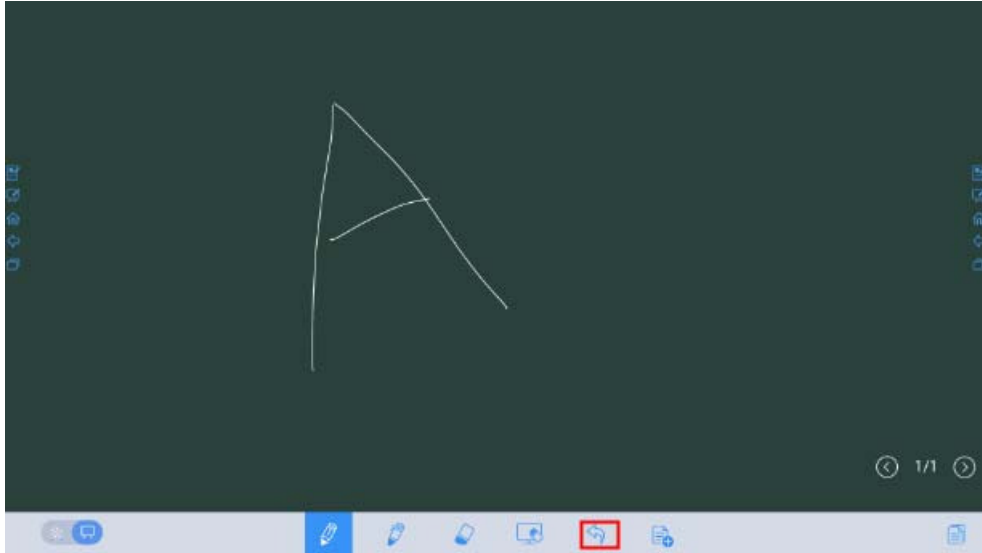
## Clear

On the whiteboard page, click  to clear all contents on the current writing slide, as shown in the following figure.



## Cancel


On the whiteboard page, click  to undo the latest operation, as shown in the following figure.



## 4.3.2 Slide Operations

You can preview, select, and delete a created writing slide.

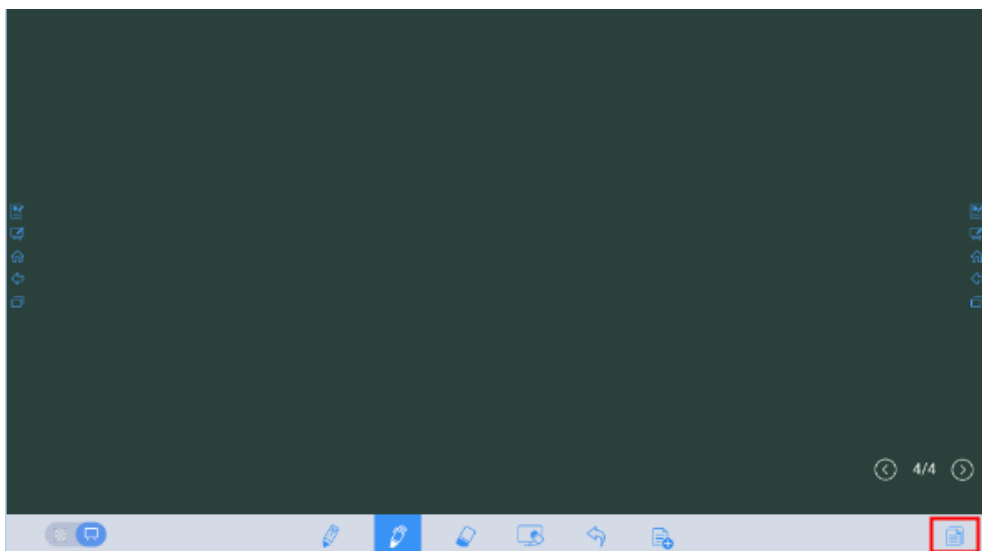
### Slide Preview

Click  at the lower right corner of the whiteboard. All writing slides are displayed. Click one slide to switch to the slide for other operations. See the following figure.











#### NOTE

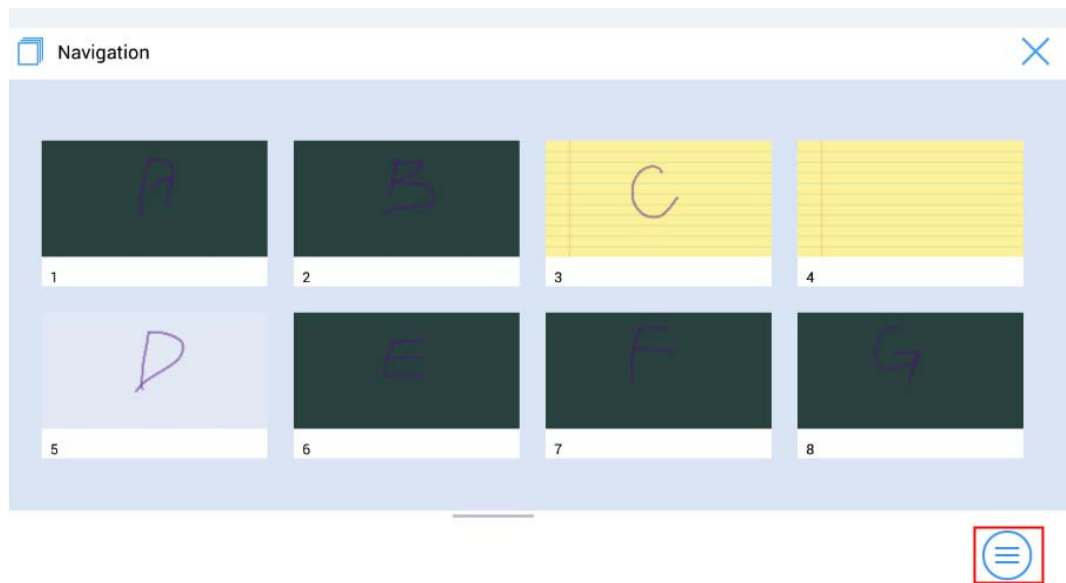
Only 8 slides are displayed in each column, and the remaining slides are displayed in the second column. You can slide one finger right or left to switch columns.



## Slide Selection and Deletion

Click . The  and  buttons are displayed. You can select and delete a writing slide as required. See the following figure.

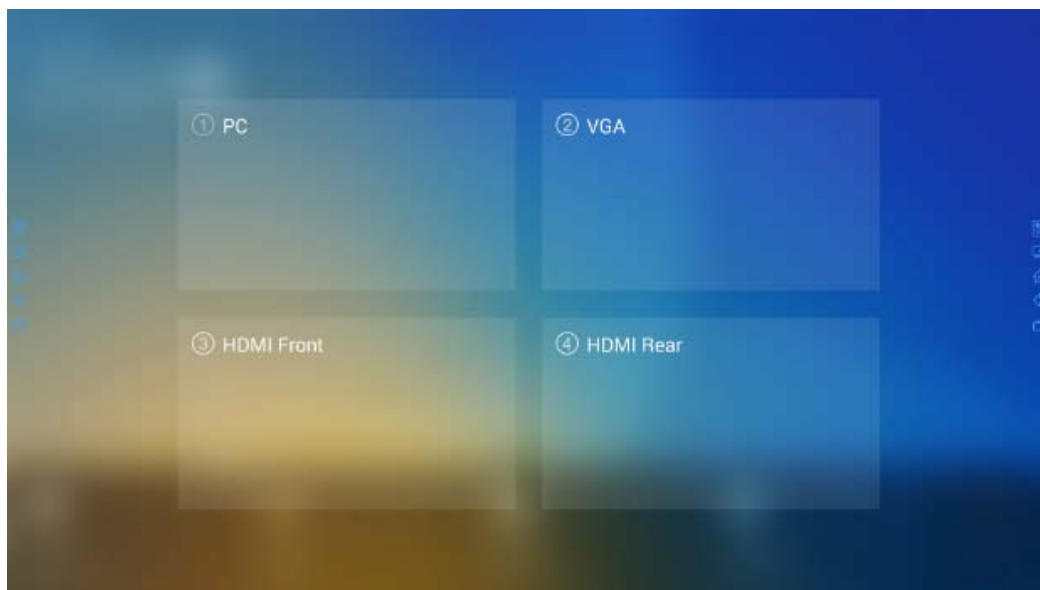
- Click the slide: to select the current slide.
- Click : to select all slides.
- Click : to delete selected slides.
- Click : Buttons on the left are replaced with .
- Click : to close the **Navigation** page.



## 4.4 Signal Source

On the home page, click **Sources**. The signal source selection page is displayed. You can preview the image of the corresponding signal channel, as shown in the following figure.

If the channel has no signal input, **No Signal** is prompted. You can click the selected signal source to switch to the corresponding channel in full screen.

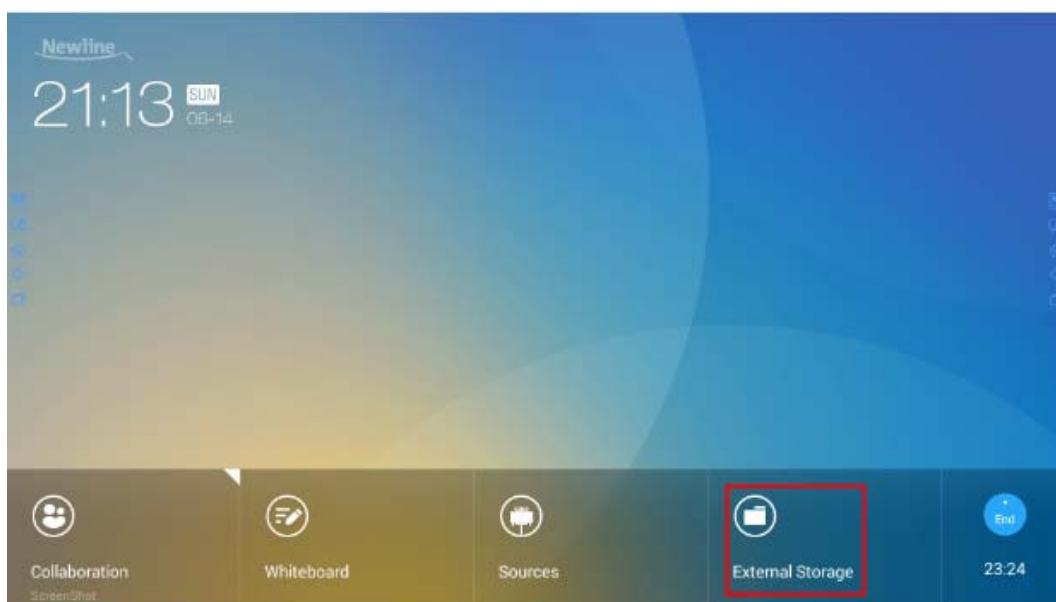


## 4.5 External Storage


The product supports connection to external storage devices. On the external storage page, you can view files stored in all external storage devices (for example, the USB flash disk and SD card) and preview, select, copy, delete and search content in each storage device.

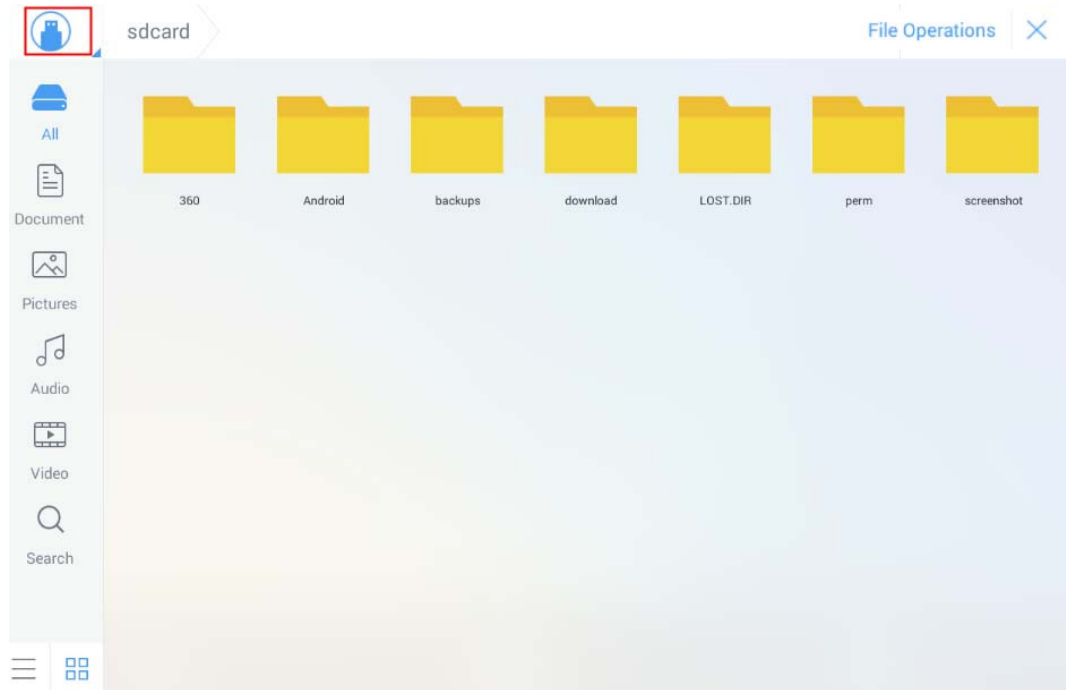
### 4.5.1 External Storage Page

On the home page, click **External Storage** as shown in the following figure.





## 4.5.2 File Preview

By default, files saved to internal storage are displayed. You can click  at the upper left corner to view all external storage devices connected to Android USB and preview a specified external storage device. See the following figure.

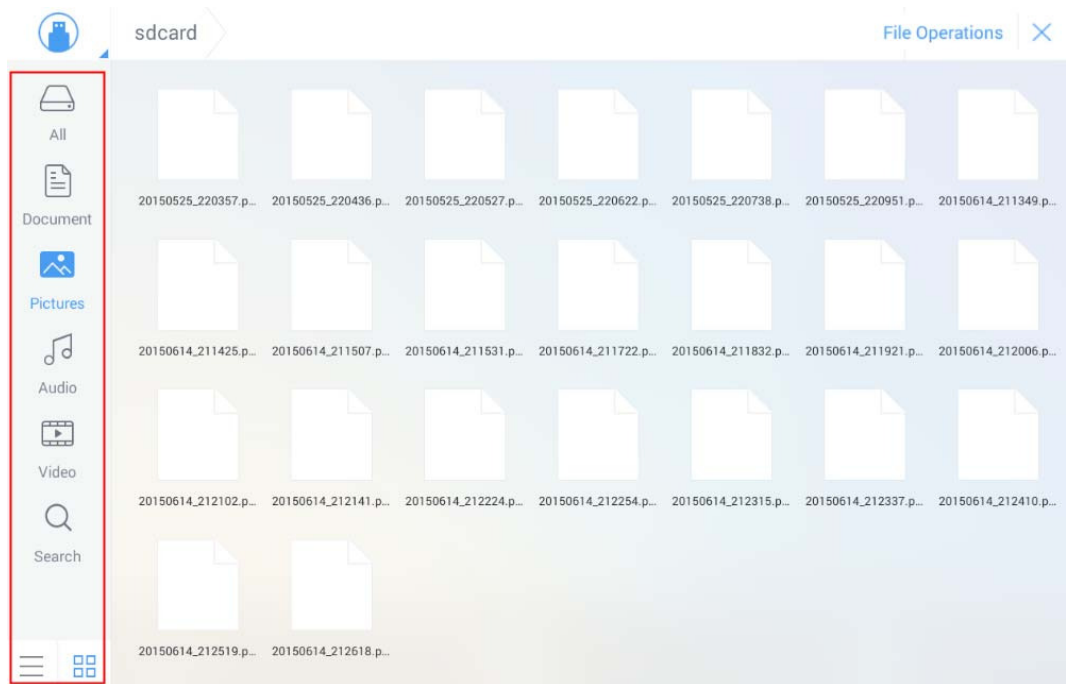


## 4.5.3 File Filtering


For your convenience, the system displays files by category, for example, document, picture, audio and video. You can click the icons on the left tool bar to filter files.

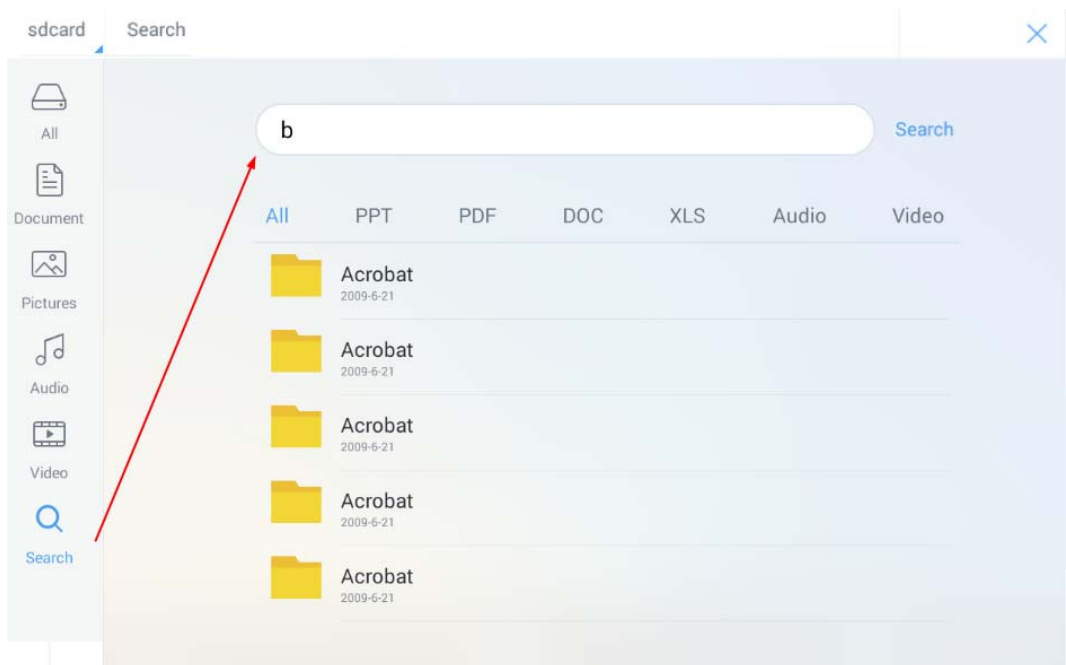
The system supports two view modes: list and thumbnail. You can click  and  at the lower left corner to switch view modes, as shown in the following figure.



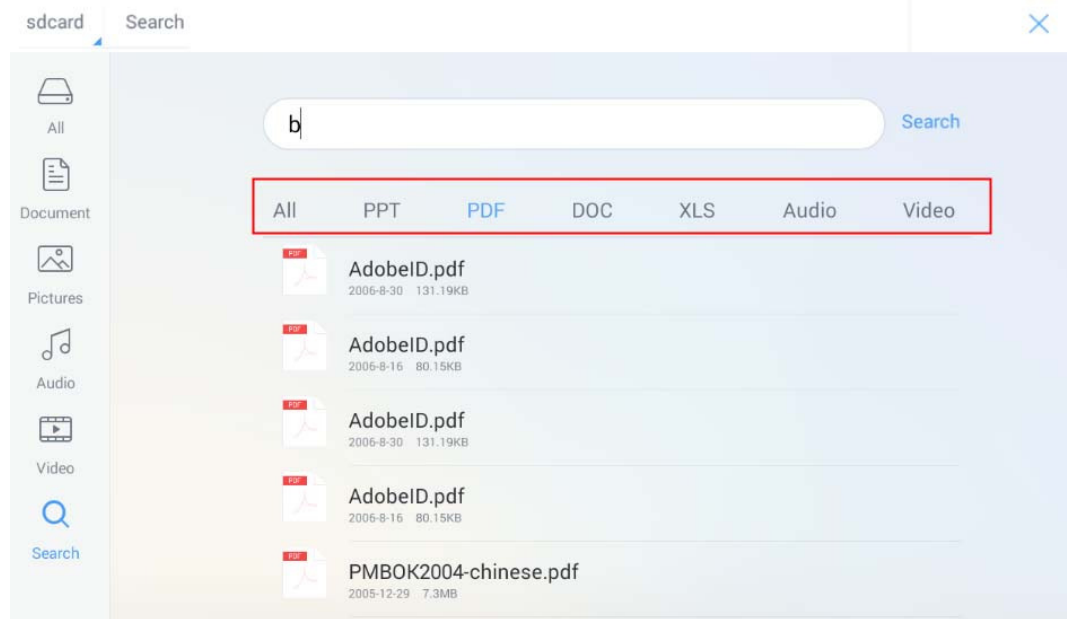


## 4.5.4 File Search

Click  and enter the key word in the search box. Files matching the key word are listed.



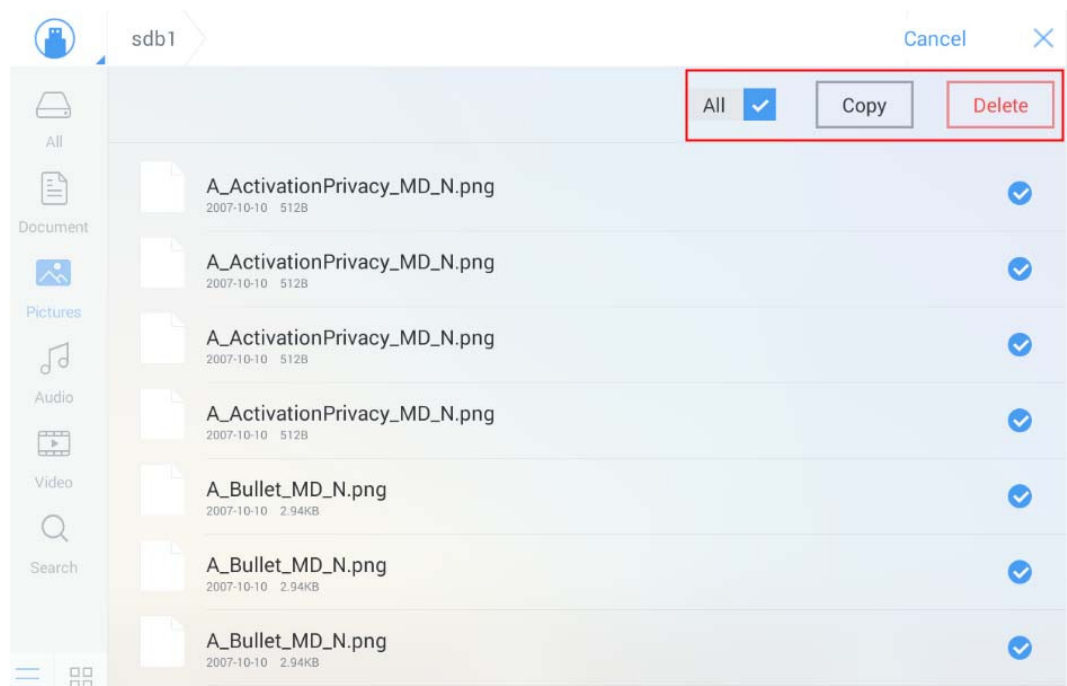
The system supports second filtering for searched files. Click the filtering tool bar below the search box to filter searched files based on PPT, PDF, DOC, XLS, Audio, and Video, as shown in the following figure.



## 4.5.5 File Operations


Click [File Operations](#) to perform operations on files in the storage, including select all files or one file, copy, delete and cancel, as shown in the following figure.

- Click the file: to select the current file.
- **All**: Select all files.
- **Copy**: Copy selected files.
- **Delete**: Delete selected files.
- **Cancel**: Cancel current operation.



## 4.6 End Meeting

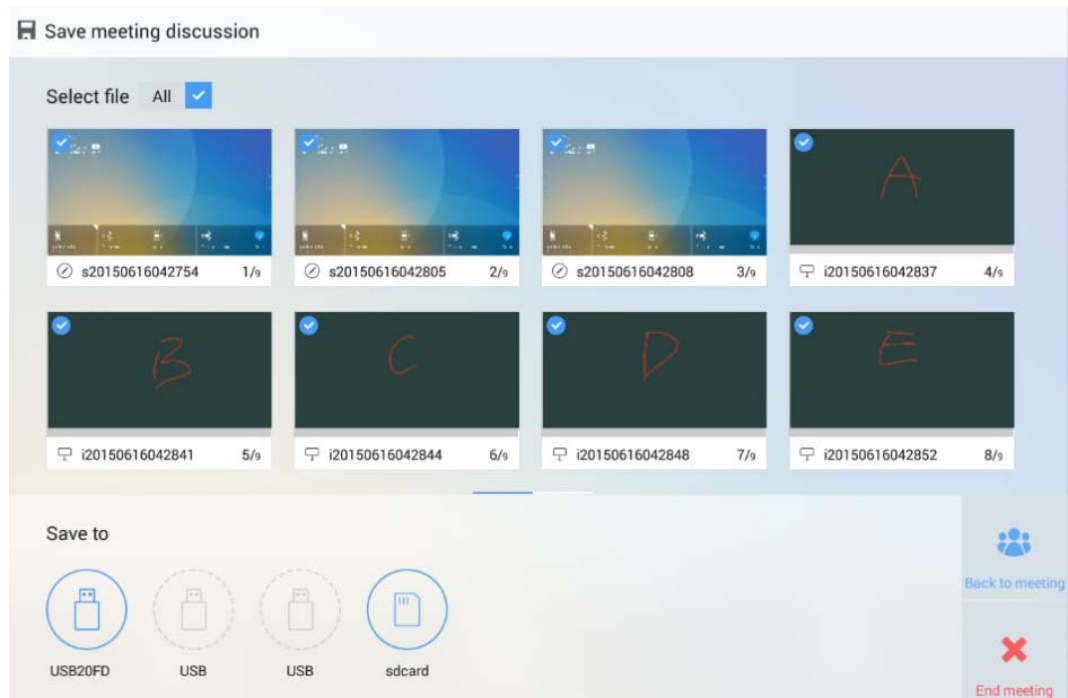
### 4.6.1 Manually End Meeting

On the home page, click . The **Save meeting discussion** page will be displayed. The meeting will be ended and timer will stop.

### File Naming

Save slides created during the meeting and annotation screenshots on the meeting record page, as shown in the following figure.

The picture is named as the creation time. You can slide right or left with one finger to switch pages.



### File Storage

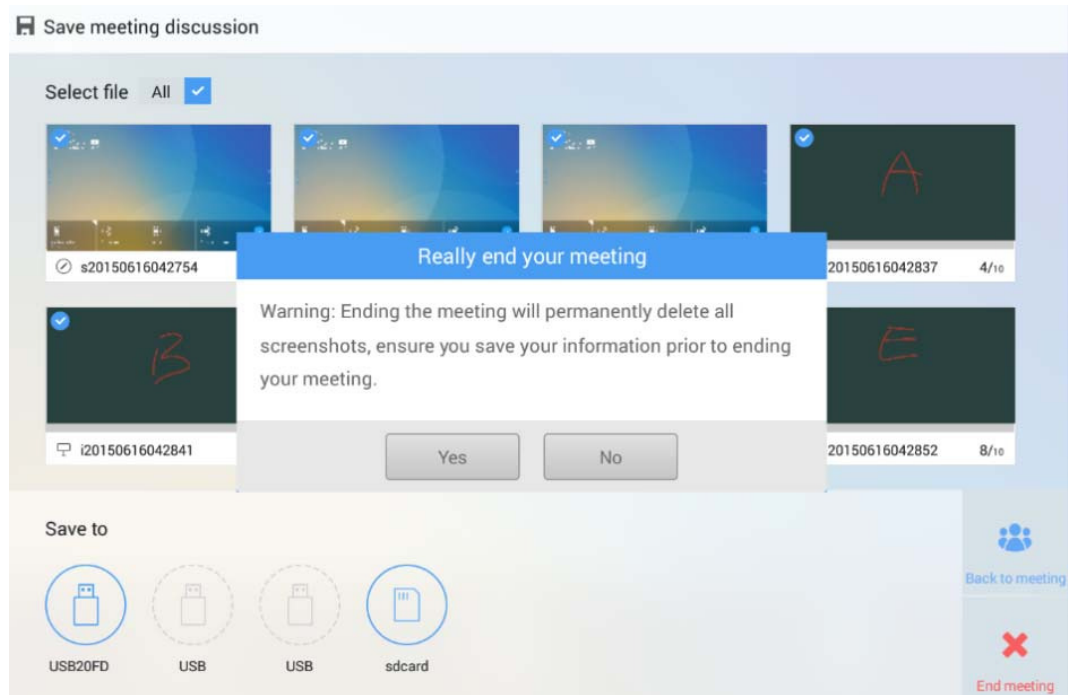
When no external USB flash disks and SD cards are connected, icons in the **Save to** area are in gray. When an external USB flash disk or SD card is connected, icons in the **Save to** area will turn into blue. Click the USB or SD card icon in blue. The system stores selected pictures to the “uc” folder under the root folder of the corresponding USB flash disk or SD card.

- **Back to meeting:** The meeting continues. Files are not cleared and timer continues.
- **End meeting:** The **Really end your meeting** dialog box is displayed.
  - Click **Yes**. All writing slides and screenshots will be deleted, and the start meeting page will be displayed (contents not saved to the external storage device will be lost). The current meeting will be ended and the timer will stop.

- Click **No**. The meeting continues and the system stays on the **Save meeting discussion** page.

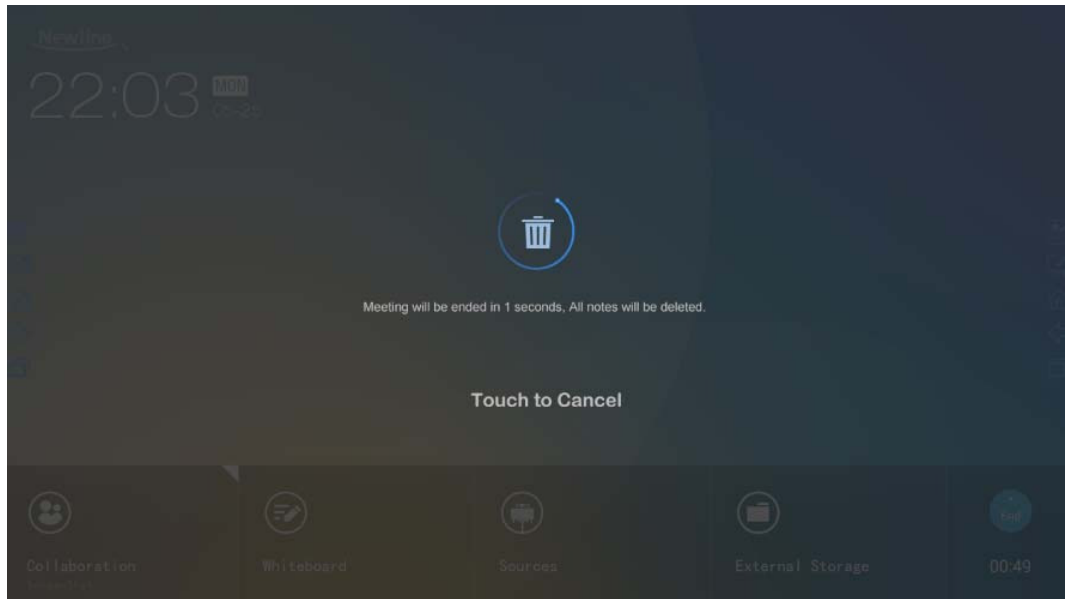
 **NOTE**

If the meeting notes can't be saved to USB drive or SD card successfully when ending meeting, please use USB drive or SD card smaller than 32GB and change the file system into FAT 32 format.



## 4.6.2 Automatically End Meeting

If the period without operations on the screen exceeds 90 minutes, the system will lock the screen automatically to protect your privacy. If the period without operations exceeds 120 seconds, the system will delete all meeting contents automatically, as shown in the following figure.



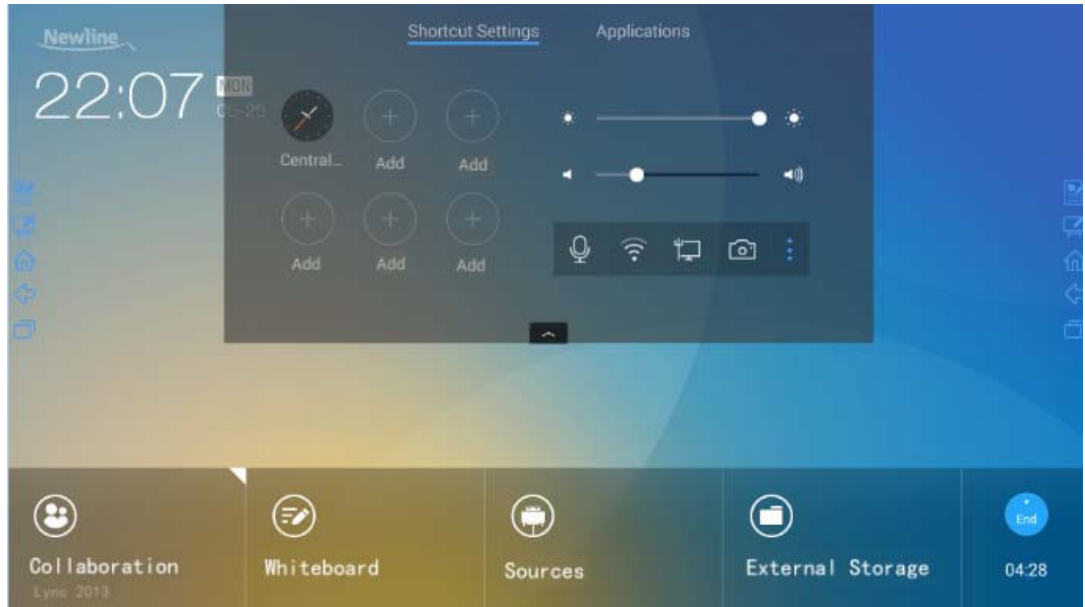
## 4.7 Shortcut Settings and Applications

Slide **one finger down for 40 to 80 mm from the top of the screen**, the **Shortcut Settings** and **Applications** pages are displayed. As shown in the following figure.




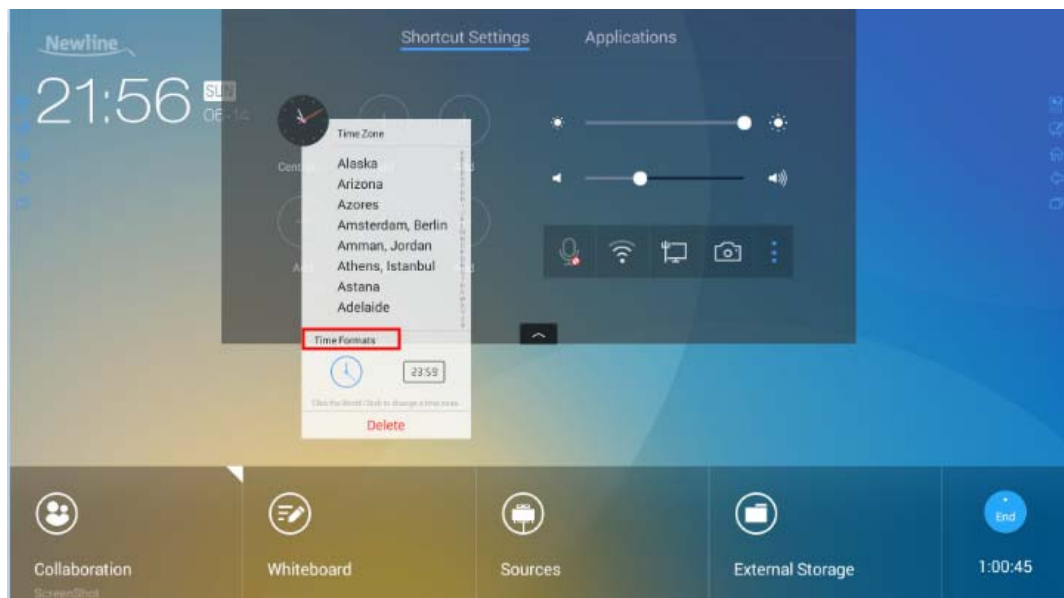
## 4.7.1 Shortcut Settings

After a top-down slide, the **Shortcut Settings** page is displayed by default, as shown in the following figure.



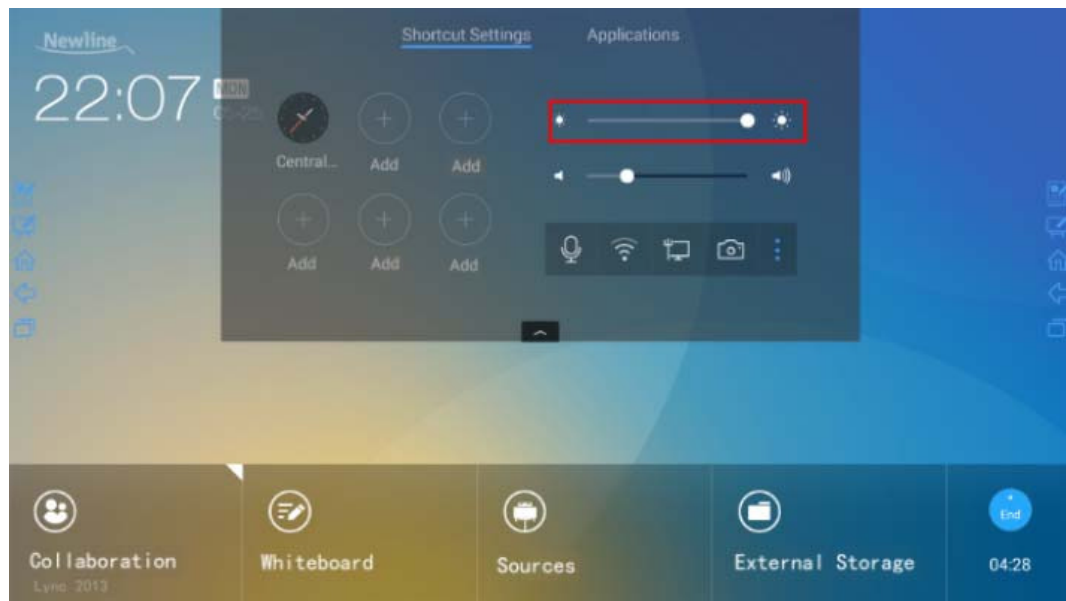
## Clock Settings

Click  to add the required time zone, and click **Time Formats** to set the time display mode (analog clock or electronic clock).



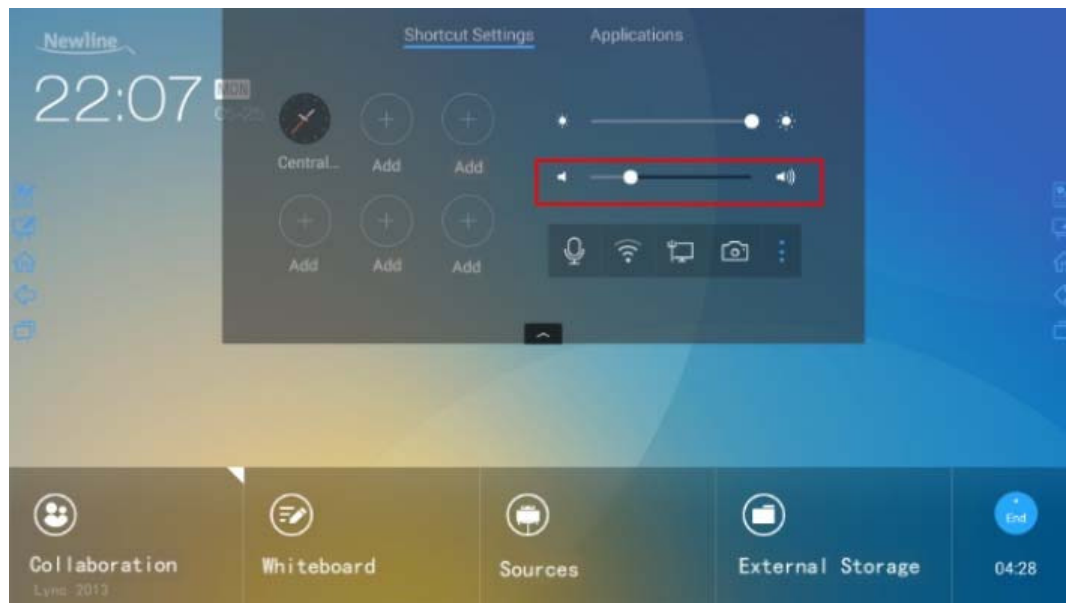
## Brightness Adjustment

Drag the slider beside the  icon to adjust the brightness.




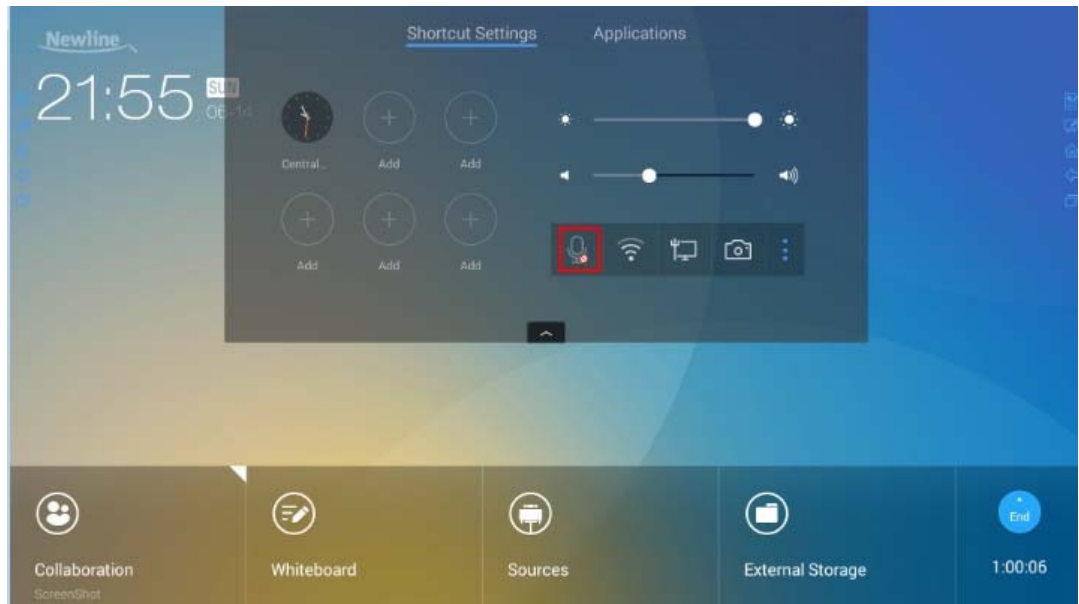
## Volume Adjustment

Drag the slider beside the  icon to adjust the volume.




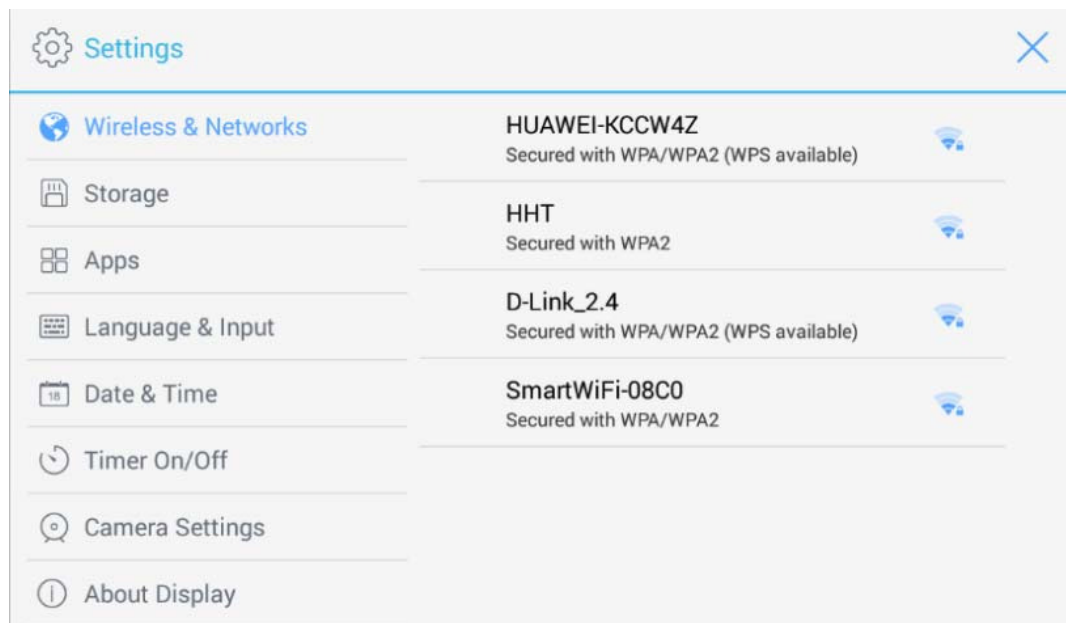
## Microphone Mute Mode

Click  to enable or disable the microphone mute mode.




## Wi-Fi Settings

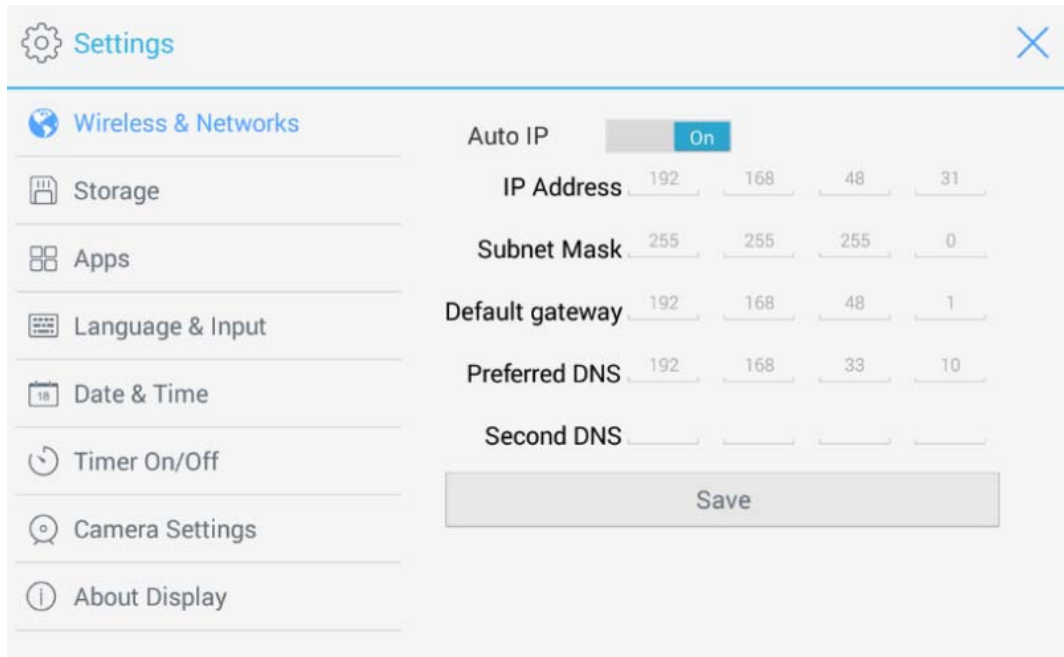
Click  to enter the system settings page and select the Wi-Fi hotspot to be connected.




## Wired Network Settings

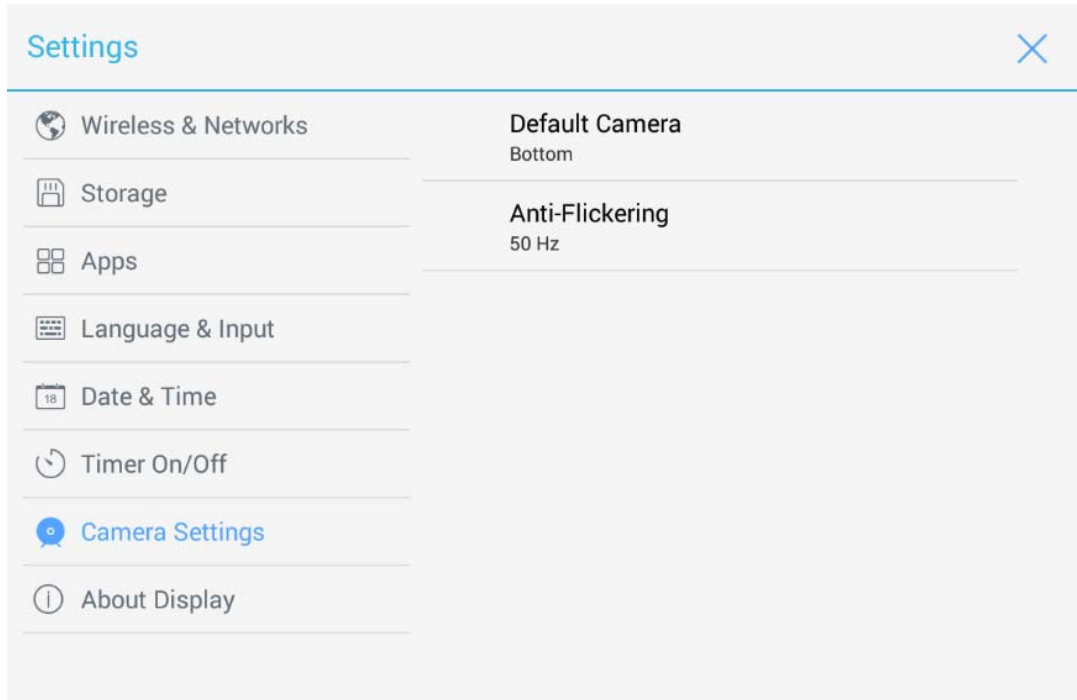
Click  to enter system settings page and set information about the wired network.





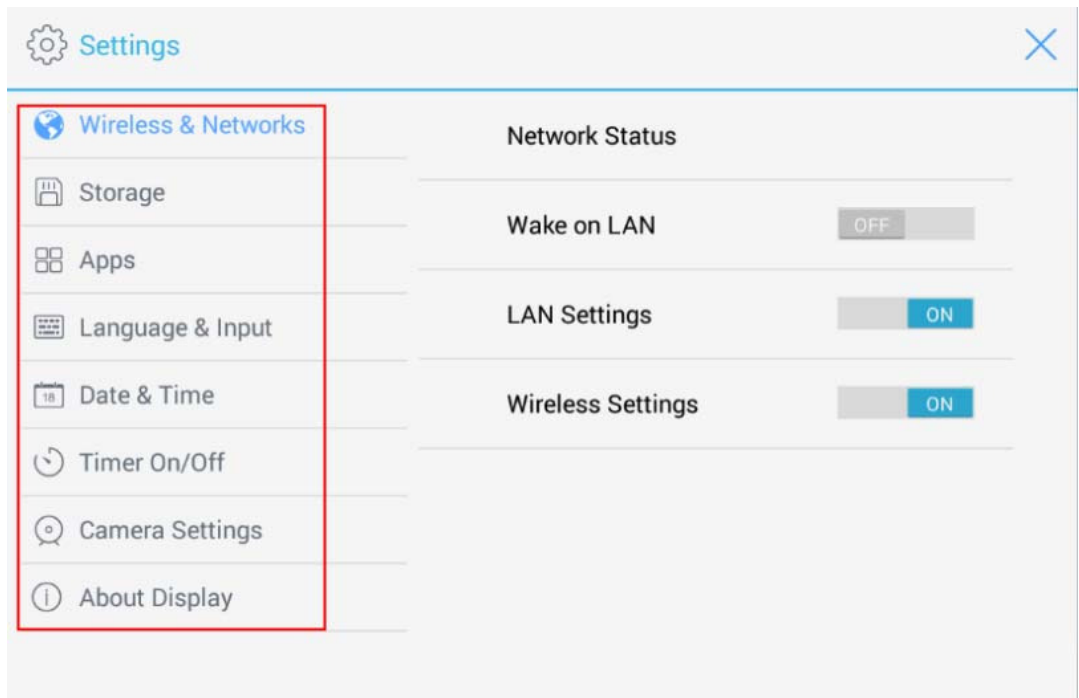
## Camera Settings

Click  to enter system settings page and set the default camera used by the display and anti-flickering information.



## System Settings

Click  to enter system settings page. Setting items are shown in the following figure.



## 4.7.2 Applications

In the assistant meeting, click **Applications** to fast select and start applications on Android system, and slide right and left on the screen to view all applications, as shown in the following figure.



# 5 Serial Port Control



---




Connect RS-232 port to the PC or controlling device. Enable RS-232 serial port connection and complete the following configuration.


<b>Port: COM1 (Set according to PC or controlling device's port number)</b>			
Bit rate	19200	Odd/even check	None
Data bits	8	Stop bit	1

The following table lists the button controlling code and return code.

<b>Function</b>	<b>Controlling codes</b>	<b>Return codes</b>
Power on	7F 08 99 A2 B3 C4 02 FF 01 00 CF	7F 09 99 A2 B3 C4 02 FF 01 00 01 CF 00
Power off	7F 08 99 A2 B3 C4 02 FF 01 01 CF	7F 09 99 A2 B3 C4 02 FF 01 01 01 CF
Mute	7F 08 99 A2 B3 C4 02 FF 01 02 CF	7F 09 99 A2 B3 C4 02 FF 01 02 01 CF
Signal source	7F 08 99 A2 B3 C4 02 FF 01 06 CF	7F 09 99 A2 B3 C4 02 FF 01 06 01 CF
Start the whiteboard	7F 08 99 A2 B3 C4 02 FF 01 07 CF	7F 09 99 A2 B3 C4 02 FF 01 07 01 CF
Display status	7F 08 99 A2 B3 C4 02 FF 01 09 CF	7F 09 99 A2 B3 C4 02 FF 01 09 01 CF
HDMI Front	7F 08 99 A2 B3 C4 02 FF 01 0A CF	7F 09 99 A2 B3 C4 02 FF 01 0A 01 CF
HDMI Rear	7F 08 99 A2 B3 C4 02 FF 01 0B CF	7F 09 99 A2 B3 C4 02 FF 01 0B 01 CF
Internal PC	7F 08 99 A2 B3 C4 02 FF 01 38 CF	7F 09 99 A2 B3 C4 02 FF 01 38 01 CF

Function	Controlling codes	Return codes
VGA	7F 08 99 A2 B3 C4 02 FF 01 0D CF	7F 09 99 A2 B3 C4 02 FF 01 0D 01 CF
Page Up	7F 08 99 A2 B3 C4 02 FF 01 13 CF	7F 09 99 A2 B3 C4 02 FF 01 13 01 CF
Page Down	7F 08 99 A2 B3 C4 02 FF 01 14 CF	7F 09 99 A2 B3 C4 02 FF 01 14 01 CF
VOL -	7F 08 99 A2 B3 C4 02 FF 01 17 CF	7F 09 99 A2 B3 C4 02 FF 01 17 01 CF
VOL +	7F 08 99 A2 B3 C4 02 FF 01 18 CF	7F 09 99 A2 B3 C4 02 FF 01 18 01 CF
Menu	7F 08 99 A2 B3 C4 02 FF 01 1B CF	7F 09 99 A2 B3 C4 02 FF 01 1B 01 CF
Home page	7F 08 99 A2 B3 C4 02 FF 01 1C CF	7F 09 99 A2 B3 C4 02 FF 01 1C 01 CF
Return (exit)	7F 08 99 A2 B3 C4 02 FF 01 1D CF	7F 09 99 A2 B3 C4 02 FF 01 1D 01 CF
Auto ADJ	7F 08 99 A2 B3 C4 02 FF 01 20 CF	7F 09 99 A2 B3 C4 02 FF 01 20 01 CF
OK	7F 08 99 A2 B3 C4 02 FF 01 2B CF	7F 09 99 A2 B3 C4 02 FF 01 2B 01 CF
←	7F 08 99 A2 B3 C4 02 FF 01 2C CF	7F 09 99 A2 B3 C4 02 FF 01 2C 01 CF
→	7F 08 99 A2 B3 C4 02 FF 01 2D CF	7F 09 99 A2 B3 C4 02 FF 01 2D 01 CF
↑	7F 08 99 A2 B3 C4 02 FF 01 2E CF	7F 09 99 A2 B3 C4 02 FF 01 2E 01 CF
↓	7F 08 99 A2 B3 C4 02 FF 01 2F CF	7F 09 99 A2 B3 C4 02 FF 01 2F 01 CF
Freeze	7F 08 99 A2 B3 C4 02 FF 01 3B CF	7F 09 99 A2 B3 C4 02 FF 01 3B 01 CF
Set volume	7F 08 99 A2 B3 C4 02 FF 05 XX CF  <b>NOTE</b> XX indicates the volume value (0 to 100), corresponding to hexadecimals 00 to 64.	7F 09 99 A2 B3 C4 02 FF 05 XX 01 CF
Set D.MODE	7F 08 99 A2 B3 C4 02 FF 06 XX CF  <b>NOTE</b> XX indicates the mode. 00 and 01 indicate standard and eco modes respectively.	7F 09 99 A2 B3 C4 02 FF 06 XX 01 CF

Function	Controlling codes	Return codes
Query the firmware version number	7F 08 99 A2 B3 C4 02 FF 01 3D CF	7F 09 99 A2 B3 C4 02 FF 01 3D 01 CF
Set Display Mode	7F 08 99 A2 B3 C4 02 FF 07 XX CF  <b>NOTE</b> XX indicates the mode. 00, 01, 02 and 03 indicate standard, bright, soft and custom modes respectively.	7F 09 99 A2 B3 C4 02 FF 07 XX 01 CF
Start the default UC program	7F 08 99 A2 B3 C4 02 FF 01 3F CF	7F 09 99 A2 B3 C4 02 FF 01 3F 01 CF
Start annotation	7F 08 99 A2 B3 C4 02 FF 01 40 CF	7F 09 99 A2 B3 C4 02 FF 01 40 01 CF
Microphone mute	7F 08 99 A2 B3 C4 02 FF 01 41 CF	7F 09 99 A2 B3 C4 02 FF 01 41 01 CF
Switch cameras	7F 08 99 A2 B3 C4 02 FF 08 XX CF  <b>NOTE</b> <ul style="list-style-type: none"><li>• XX=01 indicates that the top camera is enabled.</li><li>• XX=02 indicates that the bottom camera is enabled.</li></ul>	7F 09 99 A2 B3 C4 02 FF 08 XX 01 CF
Backlight control +	7F 08 99 A2 B3 C4 02 FF 01 47 CF	7F 09 99 A2 B3 C4 02 FF 01 47 01 CF
Backlight control -	7F 08 99 A2 B3 C4 02 FF 01 48 CF	7F 09 99 A2 B3 C4 02 FF 01 48 01 CF
Set backlight brightness	7F 08 99 A2 B3 C4 02 FF 09 XX CF <b>Note:</b> XX indicates the value of backlight brightness (0-100), corresponding to the hexadecimal number system (00-64).	7F 09 99 A2 B3 C4 02 FF 09 XX 01 CF
Read the camera position	7F 08 99 A2 B3 C4 02 FF 01 44 CF	7F 09 99 A2 B3 C4 02 FF 01 44 XX CF  <b>NOTE</b> <ul style="list-style-type: none"><li>• XX=01 indicates that the top camera is enabled.</li><li>• XX=02 indicates that the bottom camera is enabled.</li></ul>

Function	Controlling codes	Return codes
Microphone status	7F 08 99 A2 B3 C4 02 FF 01 45 CF	7F 09 99 A2 B3 C4 02 FF 01 45 XX CF  <b>NOTE</b> <ul style="list-style-type: none"> <li>• XX=01 indicates that the microphone is mute.</li> <li>• XX=02 indicates that the microphone is not mute.</li> </ul>
Read the value of backlight brightness	7F 08 99 A2 B3 C4 02 FF 01 49 CF	7F 09 99 A2 B3 C4 02 FF 01 49 XX CF <b>Note:</b> XX indicates the value of backlight brightness (0-100), corresponding to the hexadecimal number system (00-64).

# 6 Specifications

---

Parameter	Value
<b>Display</b>	
Backlight	LED
Display Area	1209.6 x 680.4mm
Active Screen Size	55"
Display Ratio	16:9
Resolution	1920*1080Pixel
Display Colors	8-bit, 16.7M colors
Brightness	370nit
Contrast	4000:1
Viewing Angle	178°
Response Time	8ms
<b>Life Time</b>	<b>30000h</b>
<b>Speaker</b>	
Speaker Position	Forward
Rated Impedance	8 Ω (±15%)
Freq. Response	80Hz(±20%) - 18kHz
Output S.P.L.	82±3dB
Max. Power Output	30W
<b>Microphone</b>	
Sensitivity	-28dB±3dB
Frequency Response	100Hz - 7.75KHz

<b>Parameter</b>	<b>Value</b>
Polar Patterns	Omnidirectional
Total Harmonic Distortion (THD)	less than 1% at 6dB SPL
Pickup range	8m
Quantity	4
<b>Camera</b>	
Position	Top x 1 & Bottom x 1 (Only one can use in the same time)
Sensor	2M Pixels
Lens	86°
Video Resolution	1920*1080@30fps (Max)
Frame Rate	30fps/60fps
<b>Electrical</b>	
Power Consumption	Maximum <120W Standby Mode≤0.5W
Working Voltage	AC 100V-240V, 50Hz/60Hz
<b>Touch</b>	
Touch Surface	Chemically strengthened soda lime glass
Transparency	>89%
Haze	0%
Surface Hardness	≥8H
Touch Technology	True Flat
HID support	HID
Touch Points	10 Points in Windows/5 Points in Android
Writing Tools	Newline Stylus or Finger
Touch Resolution	19354x10866
Scan Speed	100Hz
Positioning Accuracy	1mm
Communication Interface	USB-A
<b>Transportation/Storage</b>	
Storage Temperature/Humidity	-10°C-50°C/10%-90%



Parameter	Value
Working Temperature/Humidity	0°C-40°C/10%-90%
Mounting (optional)	Wall-mounted / Floor Stand
Outline Dimension	1320×886×87mm
Packing Dimension	1470×265×995mm
Net Weight	36Kg
Gross Weight	45Kg
<b>Ports</b>	
Front Interface Inputs	Microphone(3.5mm)×1, HDMI×1, USB(Touch)×1, USB(OPS)×1, USB(Android)×1
AV Inputs	HDMI(MHL*)×1, VGA×1, USB(Touch)×2, Audio×1
AV Outputs	3.5mm Line out x 1, HDMI x 1 (only video)
Other	USB2.0×2, RS232×1, RJ45×1, USB3.0×1, SD Reader, OPS Slot
<b>Speciality</b>	
Intelligent thermos protector	Yes
Build-in WIFI	Yes
<b>Remote Control</b>	
Technology	IR
Max Keys	26keys
Battery Type	AAA Cell
<b>Smart System</b>	
Chips	ARM Cortex A9 Quad Core 1.5GHz
RAM	2GB
Flash	8GB
Android Version	4.3
Multimedia File Formats Support	Image: JPEG, BMP, PNG Video: MPEG1, MPEG2, MPEG4, H.264, H.265, RM, RMVB, MOV, MJPEG, VC1, DivX, FLV (Support 1080P, 4K HD Decoding) Audio: MP3, M4A, (AAC)

Parameter	Value
<b>Android Software</b>	
Input Resource Preview	Yes
On Screen Annotation	Yes
Discussion Board	Yes

The above-mentioned specifications are for reference only. Newline may change the specs without additional notice. Contact local distributors for more details.

# 7 More Information

---

**For more information**

Please visit [www.newline-interactive.com](http://www.newline-interactive.com).

**Contact Us for Support**

Please email us at [support@newline-interactive.com](mailto:support@newline-interactive.com).

Newline Interactive Inc.

101 East Park Blvd. Suite 807

Plano, TX 75074

Tel: +1 (972) 468-9728

Fax: +1 (972) 422-4288

# 8 FCC Statement

---

This device complies with part 15 of the FCC Rules. Operation is subject to the following two conditions:

- (1) This device may not cause harmful interference, and
- (2) this device must accept any interference received, including interference that may cause undesired operation.

Note: The manufacturer is not responsible for any radio or TV interference caused by unauthorized modifications to this equipment. Such modifications could void the user's authority to operate this equipment. Any changes or modifications not expressly approved by the party responsible for compliance could void the user's authority to operate the equipment.

This equipment has been tested and found to comply with the limits for a Class B digital device, pursuant to part 15 of FCC Rules. These limits are designed to provide reasonable protection against harmful interference in a residential installation. This equipment generates and can radiate radio frequency energy and, if not installed and used in accordance with the instructions, may cause harmful interference to radio communications. However, there is no guarantee that interference will not occur in a particular installation. If this equipment does cause harmful interference to radio or television reception, which can be determined by turning the equipment off and on, the user is encouraged to try to correct the interference by one or more of the following measures:

- Reorient or relocate the receiving antenna.
- Increase the separation between the equipment and receiver.
- Connect the equipment into an outlet on a circuit different from that to which the receiver is connected.
- Consult the dealer or an experienced radio/TV technician for help.

## **RF warning statement**

The device has been evaluated to meet general RF exposure requirement. The device can be used with a 20cm distance restriction.