



**Shenzhen GTI Technology Co., Ltd.**

1F,2 Block, Jiaquan Building, Guanlan High-tech Park Baoan District,  
Shenzhen, Guangdong, China.

Tel: +86-755-27559792

Fax: +86-755-86116468

Report No.: GTI20160419F-1

Page 1 of 51

# TEST REPORT

**Product Name** .....: Collaboration Touch Screen

**Trademark** .....: NewLine

**Model/Type reference** .....: X5

**Listed Model(s)** .....: X5xxxxx (x=0-9,a-z,A-Z, - or blank)

**FCC ID**.....: 2ACYT-BNL16X5

**Test Standards** .....: **FCC Part 15.247: Operation within the bands 902-928 MHz, 2400-2483.5 MHz and 5725-5850 MHz**

**Applicant** .....: SHENZHEN Hitevision Technology Co., Ltd.

**Address of applicant** .....: No. 8, Qinglan 1st Road, Pingshan, Shenzhen, Guangdong  
518118, P. R. China.

**Date of Receipt** .....: June 10, 2016

**Date of Test Date**.....: June 11, 2016 to June 15, 2016

**Data of issue.** .....: June 16, 2016

<b>Test result</b>	<b>Pass *</b>
--------------------	---------------

\* In the configuration tested, the EUT complied with the standards specified above

GENERAL DESCRIPTION OF EUT	
Equipment	Collaboration Touch Screen
Model Name	X5
Adding model:	X5xxxxx (x=0-9,a-z,A-Z, - or blank)
Model differences:	x=0-9,a-z,A-Z, - or blank, It's with different model number only. Different model number should be used in different sales region and channels)
Manufacturer:	Newline Interactive Inc.
Manufacturer Address:	101 East Park Blvd. Suite 807 Plano TX 75074 U.S.A.
Power Rating:	Input: 100-240V~, 50/60Hz, Max2A

Compiled By: Thomas Morgan  
(Thomas Morgan)

Reviewed By: Tony Wang  
(Tony Wang)

Approved By: Walter Chen  
(Walter Chen)

This test report consists of 51 pages in total. It may be duplicated completely for legal use with the approval of the applicant. It should not be reproduced except in full, without the written approval of our laboratory. The client should not use it to claim product endorsement by GTI. The test results in the report only apply to the tested sample. The test report shall be invalid without all the signatures of compiler, reviewer and approver. Any objections must be raised to GTI within 15 days since the date when the report is received. It will not be taken into consideration beyond this limit.



**Table of Contents**

**Page**

<b>1. SUMMARY.....</b>	<b>4</b>
1.1. TEST STANDARDS.....	4
1.2. TEST DESCRIPTION.....	4
1.3. TEST FACILITY .....	5
1.4. MEASUREMENT UNCERTAINTY .....	5
<b>2. GENERAL INFORMATION.....</b>	<b>6</b>
2.1. ENVIRONMENTAL CONDITIONS .....	6
2.2. GENERAL DESCRIPTION OF EUT .....	6
2.3. DESCRIPTION OF TEST MODES .....	7
2.1. MEASUREMENT INSTRUMENTS LIST .....	8
2.2. TEST CONDITIONS AND RESULTS .....	9
2.3. CONDUCTED EMISSION (AC MAIN) .....	9
2.4. RADIATED EMISSION .....	12
2.5. MAXIMUM CONDUCTED OUTPUT POWER.....	20
2.6. POWER SPECTRAL DENSITY .....	21
2.7. 6dB BANDWIDTH.....	24
2.8. BAND EDGE COMPLIANCE OF RF EMISSION .....	27
2.9. SPURIOUS RF CONDUCTED EMISSION.....	32
2.10. ANTENNA REQUIREMENT.....	45
<b>3. EUT TEST PHOTO .....</b>	<b>46</b>
<b>4. PHOTOGRAPHS OF EUT CONSTRUCTIONAL .....</b>	<b>47</b>

## 1. SUMMARY

### 1.1. Test Standards

The tests were performed according to following standards:

[FCC Rules Part 15.247](#): Frequency Hopping, Direct Spread Spectrum and Hybrid Systems that are in operation within the bands of 902-928 MHz, 2400-2483.5 MHz, and 5725-5850 MHz

[ANSI C63.10-2013](#): American National Standard for Testing Unlicensed Wireless Devices

### 1.2. Test Description

FCC PART 15 15.247		
FCC Part 15.207	AC Power Conducted Emission	PASS
FCC Part 15.247(a)(2)	6dB Bandwidth	PASS
FCC Part 15.247(d)	Spurious RF Conducted Emission	PASS
FCC Part 15.247(b)	Maximum Conducted Output Power	PASS
FCC Part 15.247(e)	Power Spectral Density	PASS
FCC Part 15.109/ 15.205/ 15.209	Radiated Emissions	PASS
FCC Part 15.247(d)	Band Edge	PASS
FCC Part 15.203/15.247 (b)	Antenna Requirement	PASS

Remark: The measurement uncertainty is not included in the test result.

## 1.3. Test Facility

### 1.3.1 Address of the test laboratory

**Shenzhen General Testing & Inspection Technology Co., Ltd.**

Add: 1F, 2 Block, Jiaquan Building, Guanlan High-tech Park Baoan District, Shenzhen, Guangdong, China

### 1.3.2 Laboratory accreditation

The test facility is recognized, certified, or accredited by the following organizations:

#### IC Registration No.: 9783A

The 3m alternate test site of Shenzhen GTI Technology Co., Ltd. EMC Laboratory has been registered by Certification and Engineer Bureau of Industry Canada for the performance of with Registration NO.: 9783A on Aug, 2011.

#### FCC-Registration No.: 214666

Shenzhen GTI Technology Co., Ltd. EMC Laboratory has been registered and fully described in a report filed with the (FCC) Federal Communications Commission. The acceptance letter from the FCC is maintained in our files. Registration 214666, Sep 19, 2011

## 1.4. Measurement Uncertainty

The data and results referenced in this document are true and accurate. The reader is cautioned that there may be errors within the calibration limits of the equipment and facilities. The measurement uncertainty was calculated for all measurements listed in this test report acc. to CISPR 16 - 4 Specification for radio disturbance and immunity measuring apparatus and methods – Part 4: Uncertainty in EMC Measurements and is documented in the Shenzhen General Testing & Inspection Technology Co., Ltd quality system acc. to DIN EN ISO/IEC 17025. Furthermore, component and process variability of devices similar to that tested may result in additional deviation. The manufacturer has the sole responsibility of continued compliance of the device.

Hereafter the best measurement capability for General Testing & Inspection laboratory is reported:

Test Items	Measurement Uncertainty	Notes
Transmitter power conducted	0.57 dB	(1)
Transmitter power Radiated	2.20 dB	(1)
Conducted spurious emission 9KHz-40 GHz	1.60 dB	(1)
Radiated spurious emission 9KHz-40 GHz	2.20 dB	(1)
Conducted Emission 9KHz-30MHz	3.39 dB	(1)
Radiated Emission 30~1000MHz	4.24 dB	(1)
Radiated Emission 1~18GHz	5.16 dB	(1)
Radiated Emission 18-40GHz	5.54 dB	(1)
Occupied Bandwidth	-----	(1)

(1) This uncertainty represents an expanded uncertainty expressed at approximately the 95% confidence level using a coverage factor of k=1.96.

## 2. GENERAL INFORMATION

### 2.1. Environmental conditions

During the measurement the environmental conditions were within the listed ranges:

Temperature:	15~35°C
Relative Humidity:	30~60 %
Air Pressure:	950~1050mba

### 2.2. General Description of EUT

Product Name:	Collaboration Touch Screen
Model/Type reference:	X5
Listed Model(s):	X5xxxxx (x=0-9,a-z,A-Z, - or blank)
Model(s) Differences:	x=0-9,a-z,A-Z, - or blank, It's with different model number only. Different model number should be used in different sales region and channels)
Power Rating:	Input: 100-240VAC, 50/60Hz, Max2A
Hardware version:	UC-918-X5 V02
Software version:	V4.3
<b>WIFI</b>	
Supported type:	802.11b/802.11g/802.11n(H20)/802.11n(H40)
Modulation technology:	802.11b: DSSS 802.11g/802.11n(H20)/802.11n(H40): OFDM
Modulation type:	802.11b: BPSK/QPSK/CCK 802.11g/802.11n(H20)/802.11n(H40): BPSK/QPSK/16QAM/64QAM
Operation frequency:	802.11b/802.11g/802.11n(HT20): 2412MHz~2462MHz 802.11n(HT40): 2422MHz~2452MHz
Channel number:	802.11b/802.11g/802.11n(HT20): 11 802.11n(HT40): 7
Channel separation:	5MHz
Antenna type:	Monopole Antenna
Antenna gain:	3.0dBi

Note: For a more detailed features description, please refer to the manufacturer's specifications or the User's Manual.

## 2.3. Description of Test Modes

### Peripheral equipment list

Name:	Model:	Serial	Manufacture	Remark
Laptop Computer	Elitebook 2540p	CND05201BS	HP	---

### WIFI Operation Frequency

The Applicant provides engineering files to control the EUT for staying in continuous transmitting (Duty Cycle more than 98%) mode for testing.

Note: The engineering sample had fixed the transmit parameter by the fixed files that the manufacture supplied. The fixed parameter: modulation style, channel, power level, bandwidth

For example 802.11b-Low channel is a single file, the 802.11b-middle is a single file, the same as others.

Channel	Frequency(MHz)	Channel	Frequency(MHz)
1	2412	8	2447
2	2417	9	2452
3	2422	10	2457
4	2427	11	2462
5	2432		
6	2437		
7	2442		

### Data Rate Used:

Preliminary tests were performed in different data rate to find the worst radiated emission. The data rate shown in the table below is the worst-case rate with respect to the specific test item. Investigation has been done on all the possible configurations for searching the worst cases. The following table is a list of the test modes shown in this test report.

Test Items	Mode	Data Rate	Channel
Maximum Peak Conducted Output Power Power Spectral Density 6dB Bandwidth Spurious RF conducted emission Radiated Emission 9kHz~1GHz& Radiated Emission 1GHz~10th Harmonic	11b/DSSS	1 Mbps	1/6/11
	11g/OFDM	6 Mbps	1/6/11
	11n(20MHz)/OFDM	6.5Mbps	1/6/11
	11n(40MHz)/OFDM	MCS0	3/6/9
Band Edge	11b/DSSS	1 Mbps	1/11
	11g/OFDM	6 Mbps	1/11
	11n(20MHz)/OFDM	6.5Mbps	1/11
	11n(40MHz)/OFDM	MCS0	3/6/9

## 2.1. Measurement Instruments List

Maximum Conducted Output Power/Power Spectral Density / 6dB Bandwidth / Band Edge Compliance of RF Emission / Spurious RF Conducted Emission					
Item	Test Equipment	Manufacturer	Model No.	Serial No.	Calibrated until
1	Power Meter	Anritsu	ML2487B	110553	July 10,2016
2	Power Sensor	Anritsu	MA2411B	100345	July 10,2016
3	Spectrum Analyzer	Rohde & Schwarz	FSU	100105	Jan 04,2017
4	RF Cable	Schwarzbeck	AH32D4	SF0150	Jan 04,2017
5	Temporary Antenna connector	Schwarzbeck	SMA24D	ED1201	Jan 04,2017

Note: The temporary antenna connector is soldered on the PCB board in order to perform conducted tests and this temporary antenna connector is listed in the equipment list.

Conducted Emission					
Item	Test Equipment	Manufacturer	Model No.	Serial No.	Calibrate until
1	LISN	R&S	ENV216	101112	Jan. 04, 2017
2	LISN	R&S	ENV216	101113	Jan. 04, 2017
3	EMI Test Receiver	R&S	ESCI	100920	Jan. 04, 2017
4	Cable	Schwarzbeck	AK9515E	33156	Jan. 04, 2017

Radiated Emission					
Item	Test Equipment	Manufacturer	Model No.	Serial No.	Calibrated until
1	EMI Test Receiver	R&S	ESCI	100967	Jan 04,2017
2	High pass filter	micro-tranics	HPM50111	34202	Jan 04,2017
3	Log-Bicon Antenna	Schwarzbeck	CBL6141A	4180	Jan 04,2017
4	Ultra-Broadband Antenna	ShwarzBeck	BBHA9170	25841	Jan 07,2017
5	Loop Antenna	LAPLAC	RF300	9138	Jan 07,2017
6	Spectrum Analyzer	Rohde & Schwarz	FSU	100105	Jan 04,2017
7	Horn Antenna	Schwarzbeck	BBHA 9120D	648	Jan 07,2017
8	Pre-Amplifier	HP	8447D	1937A03050	Jan 04,2017
9	Pre-Amplifier	EMCI	EMC05183 5	980075	Jan 04,2017
10	Antenna Mast	UC	UC3000	N/A	N/A
11	Turn Table	UC	UC3000	N/A	N/A
12	Cable Below 1GHz	Schwarzbeck	AK9515E	33155	Jan 04,2017
13	Cable Above 1GHz	Hubersuhner	SUCOFLEX1 02	DA1580	Jan 04,2017

Note: 1. The Cal.Interval was one year.

2. The cable loss has calculated in test result which connection between each test instruments.



## 2.2. TEST CONDITIONS AND RESULTS

### 2.3. Conducted Emission (AC Main)

#### LIMIT

FCC CFR Title 47 Part 15 Subpart C Section 15.207

Frequency range (MHz)	Limit (dBuV)	
	Quasi-peak	Average
0.15-0.5	66 to 56*	56 to 46*
0.5-5	56	46
5-30	60	50

\* Decreases with the logarithm of the frequency.

#### TEST CONFIGURATION

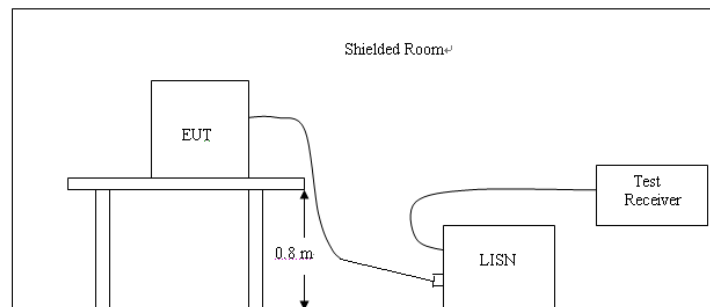

#### TEST PROCEDURE

1. The equipment was set up as per the test configuration to simulate typical actual usage per the user's manual. The EUT is a tabletop system; a wooden table with a height of 0.8 meters is used and is placed on the ground plane as per ANSI C63.10-2013.
2. Support equipment, if needed, was placed as per ANSI C63.10-2013
3. All I/O cables were positioned to simulate typical actual usage as per ANSI C63.10-2013
4. The EUT received AC120V/60Hz power through a Line Impedance Stabilization Network (LISN) which supplied power source and was grounded to the ground plane.
5. All support equipments received AC power from a second LISN, if any.
6. The EUT test program was started. Emissions were measured on each current carrying line of the EUT using a spectrum Analyzer / Receiver connected to the LISN powering the EUT. The LISN has two monitoring points: Line 1 (Hot Side) and Line 2 (Neutral Side). Two scans were taken: one with Line 1 connected to Analyzer / Receiver and Line 2 connected to a 50 ohm load; the second scan had Line 1 connected to a 50 ohm load and Line 2 connected to the Analyzer / Receiver.
7. Analyzer / Receiver scanned from 150 KHz to 30MHz for emissions in each of the test modes.
8. During the above scans, the emissions were maximized by cable manipulation.

#### TEST RESULTS

**Note:** We tested all modes, recorded the worst case at wifi 802.11b mode L Channel with HDMI scrolling H

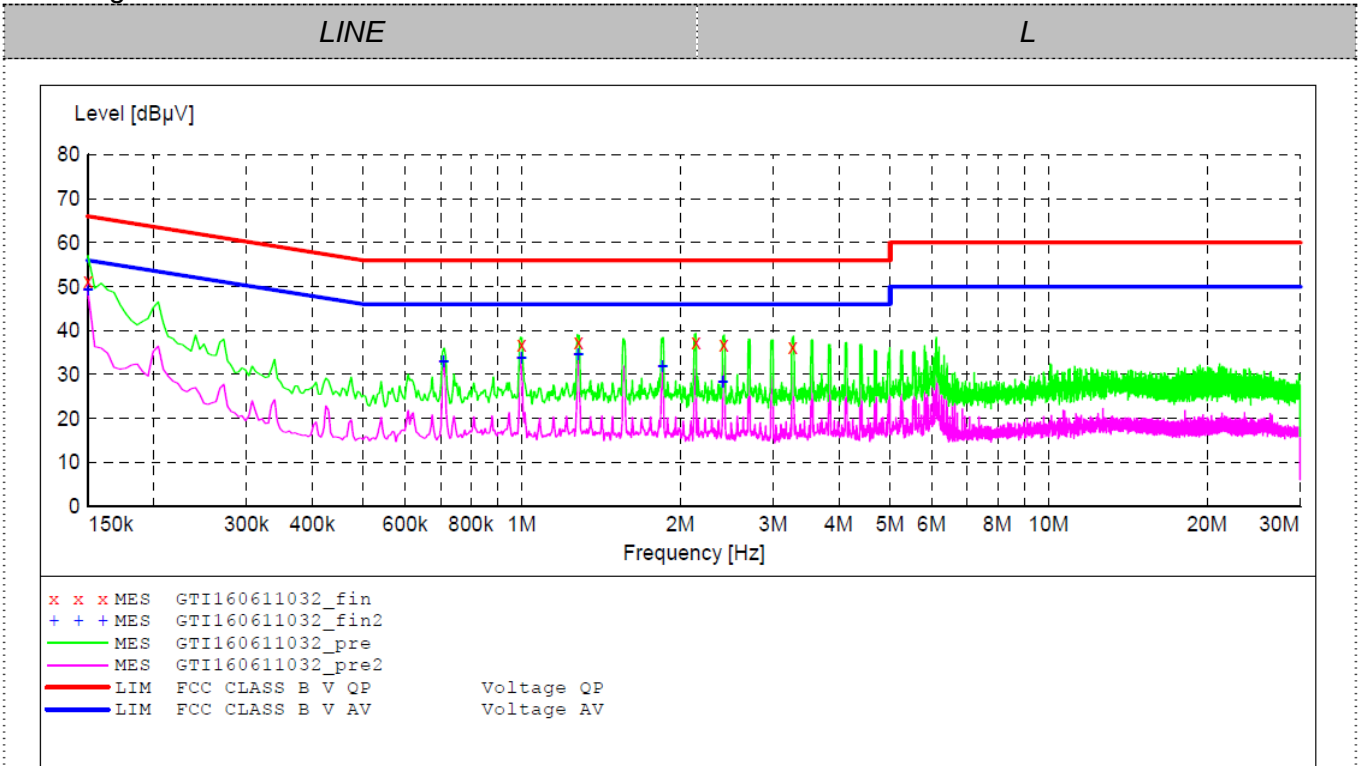

**MEASUREMENT RESULT: "GTI160611032\_fin"**

6/11/2016 2:12PM

Frequency MHz	Level dBµV	Transd dB	Limit dBµV	Margin dB	Detector	Line	PE
0.150000	51.30	9.8	66	14.7	QP	L1	GND
0.998000	36.70	10.0	56	19.3	QP	L1	GND
1.280000	37.30	10.1	56	18.7	QP	L1	GND
2.138000	37.50	10.3	56	18.5	QP	L1	GND
2.414000	36.70	10.3	56	19.3	QP	L1	GND
3.266000	36.20	10.4	56	19.8	QP	L1	GND

**MEASUREMENT RESULT: "GTI160611032\_fin2"**

6/11/2016 2:12PM

Frequency MHz	Level dBµV	Transd dB	Limit dBµV	Margin dB	Detector	Line	PE
0.150000	49.30	9.8	56	6.7	AV	L1	GND
0.710000	32.90	9.9	46	13.1	AV	L1	GND
0.998000	33.90	10.0	46	12.1	AV	L1	GND
1.280000	34.70	10.1	46	11.3	AV	L1	GND
1.850000	32.00	10.2	46	14.0	AV	L1	GND
2.408000	28.50	10.3	46	17.5	AV	L1	GND

**LINE** **N**

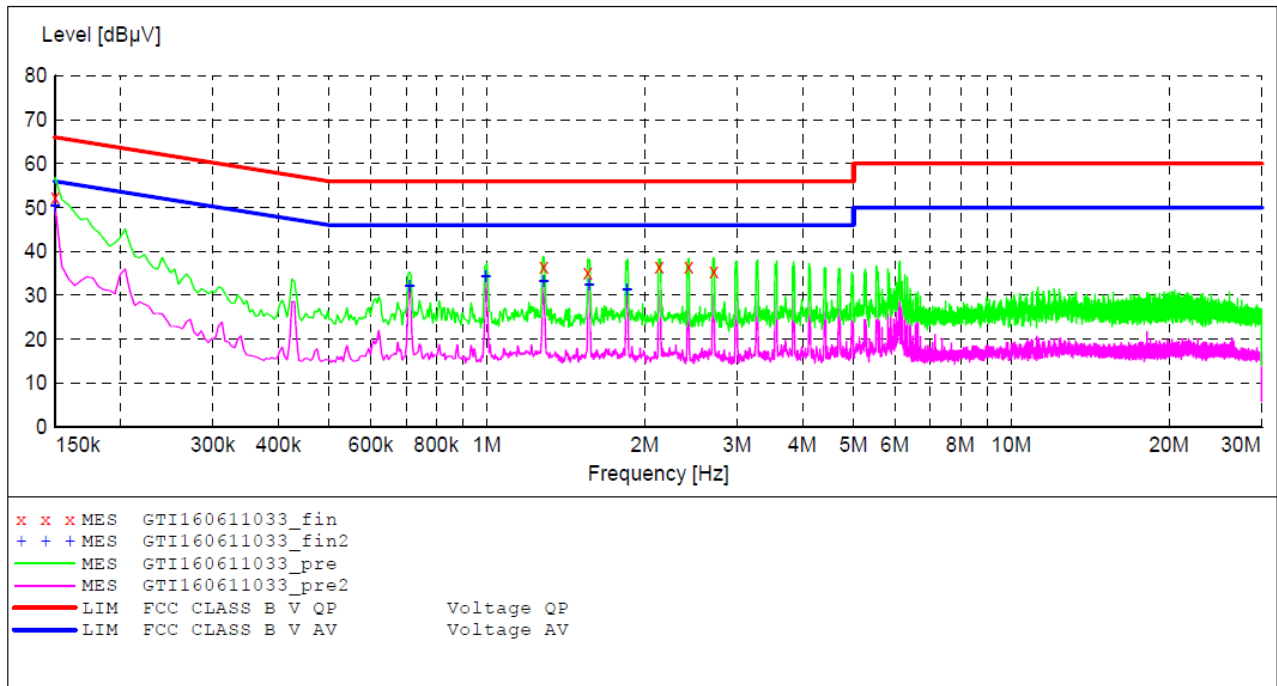

**MEASUREMENT RESULT: "GTI160611033\_fin"**

6/11/2016 2:15PM

Frequency MHz	Level dBµV	Transd dB	Limit dBµV	Margin dB	Detector	Line	PE
0.150000	52.30	9.5	66	13.7	QP	N	GND
1.283000	36.50	9.8	56	19.5	QP	N	GND
1.557500	35.10	9.9	56	20.9	QP	N	GND
2.129000	36.60	10.0	56	19.4	QP	N	GND
2.426000	36.40	10.1	56	19.6	QP	N	GND
2.705000	35.60	10.1	56	20.4	QP	N	GND

**MEASUREMENT RESULT: "GTI160611033\_fin2"**

6/11/2016 2:15PM

Frequency MHz	Level dBµV	Transd dB	Limit dBµV	Margin dB	Detector	Line	PE
0.150000	50.50	9.5	56	5.5	AV	N	GND
0.711500	32.20	9.6	46	13.8	AV	N	GND
0.995000	34.30	9.7	46	11.7	AV	N	GND
1.283000	33.30	9.8	46	12.7	AV	N	GND
1.566500	32.30	9.9	46	13.7	AV	N	GND
1.850000	31.50	10.0	46	14.5	AV	N	GND

## 2.4. Radiated Emission

### Limit

For intentional device, according to § 15.209(a), the general requirement of field strength of radiated emission from intentional radiators at a distance of 3 meters shall not exceed the following table. According to § 15.247(d), in any 100kHz bandwidth outside the frequency band in which the EUT is operating, the radio frequency power that is produced by the intentional radiator shall be at least 20dB below that in the 100kHz bandwidth within the band that contains the highest level of desired power.

The frequency spectrum above 1 GHz for Transmitter was investigated. All emission not reported are much lower than the prescribed limits. Set the RBW=1MHz, VBW=3MHz for Peak Detector while the RBW=1MHz, VBW=10Hz for Average Detector, Readings are both peak and average values. The pre-test have done for the EUT in three axes and found the worst emission at position shown in test setup photos.

Frequency (MHz)	Distance (Meters)	Radiated (dBuV/m)	Radiated ( $\mu$ V/m)
0.009-0.49	3	$20\log(2400/F(\text{KHz}))+40\log(300/3)$	$2400/F(\text{KHz})$
0.49-1.705	3	$20\log(24000/F(\text{KHz}))+40\log(30/3)$	$24000/F(\text{KHz})$
1.705-30	3	$20\log(30)+40\log(30/3)$	30
30-88	3	40.0	100
88-216	3	43.5	150
216-960	3	46.0	200
Above 960	3	54.0	500

### Test Procedure

1. For below 1GHz test, The EUT was placed on a turn table which is 0.8m above ground plane. For Above 1GHz test, The EUT was placed on a turn table which is 1.5m above ground plane;
2. Maximum procedure was performed by raising the receiving antenna from 1m to 4m and rotating the turn table from 0° to 360° to acquire the highest emissions from EUT
3. And also, each emission was to be maximized by changing the polarization of receiving antenna both horizontal and vertical.
4. Repeat above procedures until all frequency measurements have been completed.

Note: For the radiated emission test above 1GHz:

Place the measurement antenna away from each area of the EUT determined to be a source of emissions at the specified measurement distance, while keeping the measurement antenna aimed at the source of emissions at each frequency of significant emissions, with polarization oriented for maximum response. The measurement antenna may have to be higher or lower than the EUT, depending on the radiation pattern of the emission and staying aimed at the emission source for receiving the maximum signal. The final measurement antenna elevation shall be that which maximizes the emissions. The measurement antenna elevation for maximum emissions shall be restricted to a range of heights of from 1 m to 4 m above the ground or reference ground plane.

### Field Strength Calculation

The field strength is calculated by adding the Antenna Factor and Cable Factor and subtracting the Amplifier Gain and Duty Cycle Correction Factor (if any) from the measured reading. The basic equation with a sample calculation is as follows:

$$FS = RA + AF + CL - AG$$

Where FS = Field Strength	CL = Cable Attenuation Factor (Cable Loss)
RA = Reading Amplitude	AG = Amplifier Gain
AF = Antenna Factor	

For example

Frequency (MHz)	FS (dB $\mu$ V/m)	RA (dB $\mu$ V/m)	AF (dB)	CL (dB)	AG (dB)	Transd (dB)
150.00	40	58.1	12.2	1.6	31.90	-18.1

Transd=AF +CL-AG

### Test Configuration

For the actual test configuration, please refer to the related Item –EUT Test Photos.

#### Frequency range 9 KHz – 30MHz

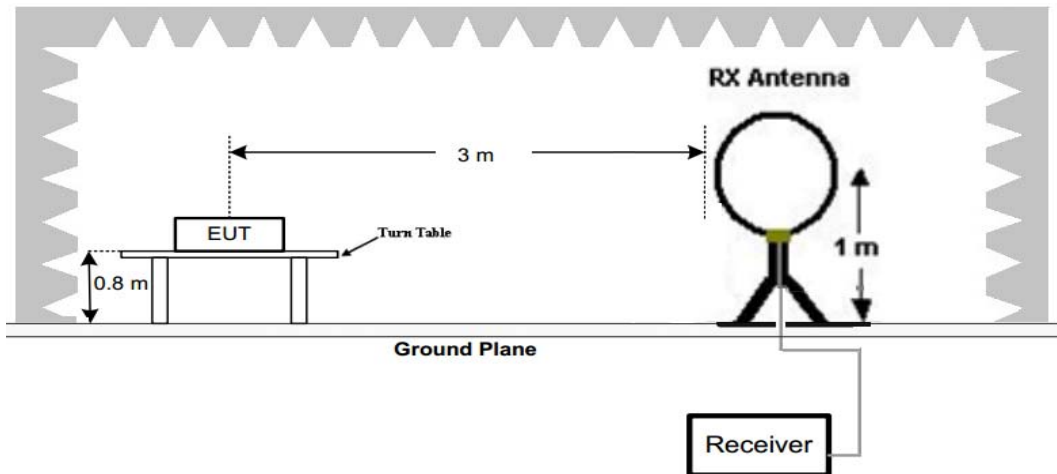

#### Frequency range 30MHz – 1000MHz

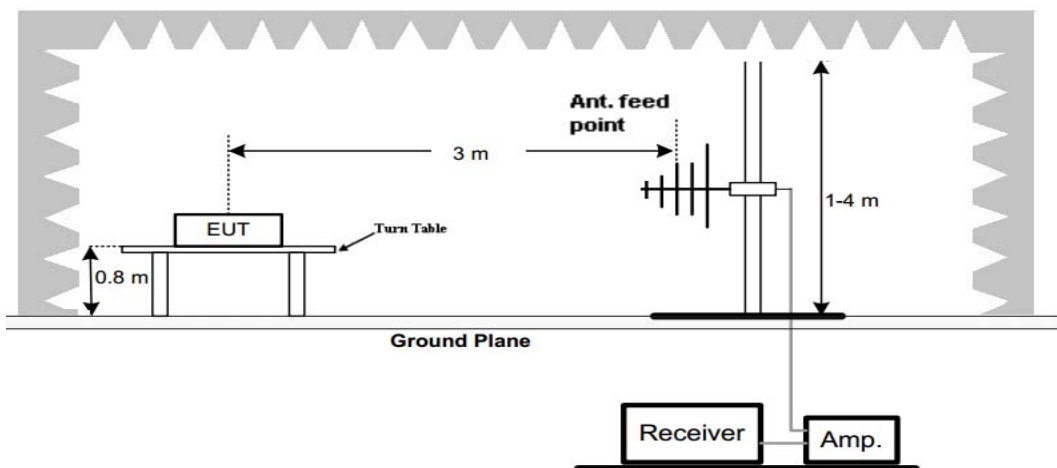

**Frequency range above 1GHz-25GHz**

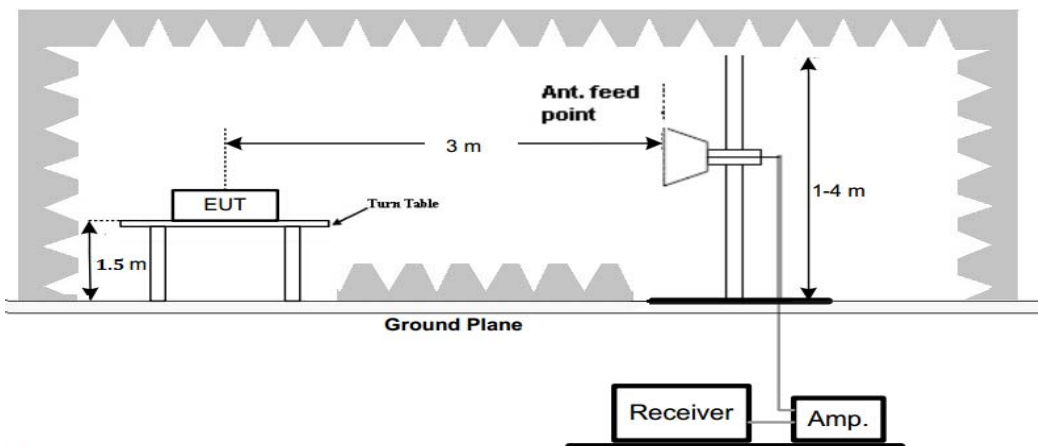

**Test Results**

Remark:

1. We tested three channels for each mode and recorded worst case at low channel of 802.11b Mode below 1GHz

**For 9 KHz-30MHz**

Frequency (MHz)	Corrected Reading (dBuV/m)@3m	FCC Limit (dBuV/m) @3m	Margin (dB)	Detector	Result
0.21	49.28	101.16	51.88	QP	PASS
1.42	29.25	64.56	35.31	QP	PASS
16.11	38.35	69.54	31.19	QP	PASS
25.05	49.35	69.54	20.19	QP	PASS

For 30MHz-1GHz

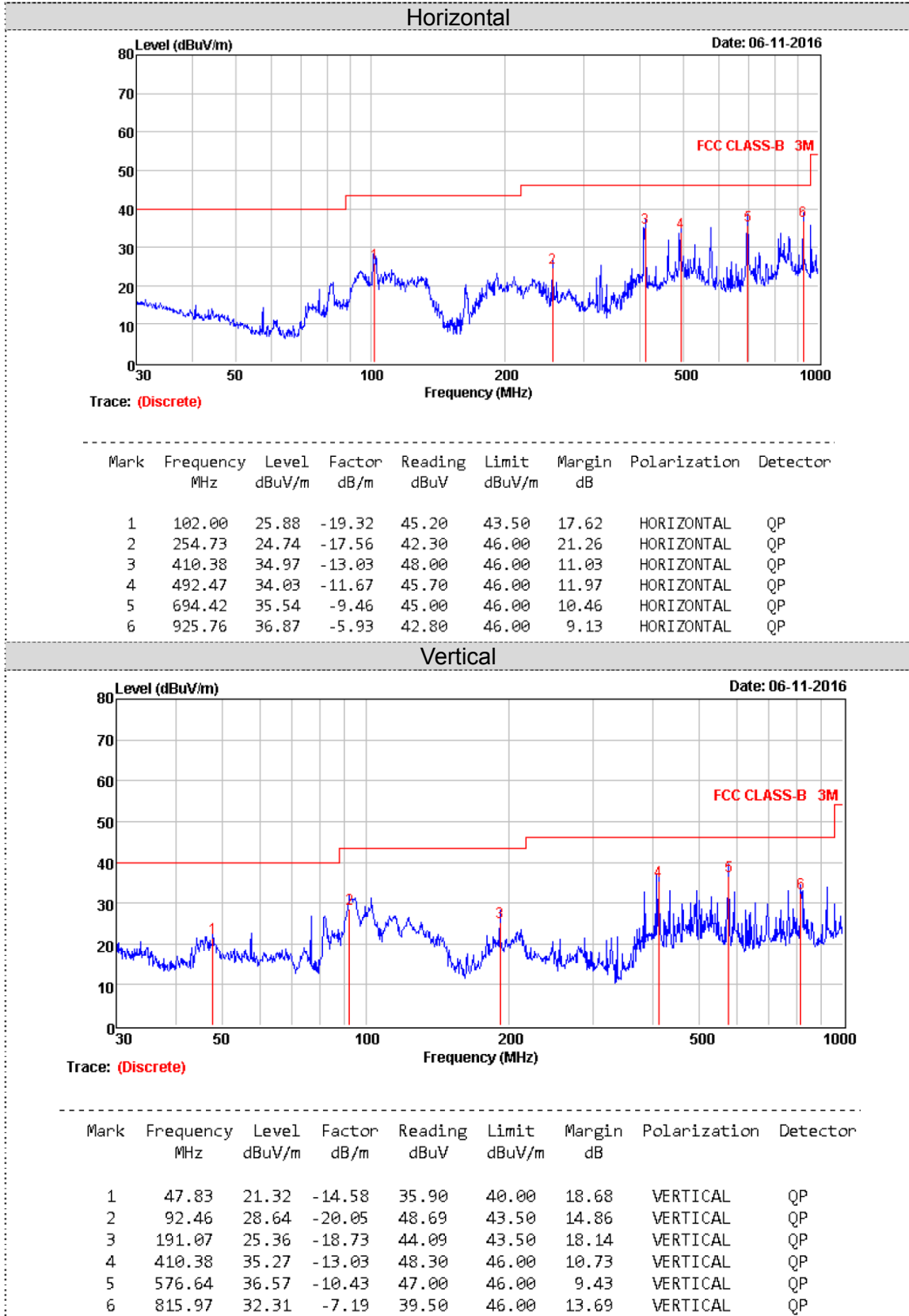



For 1GHz to 25GHz

802.11b Mode (above 1GHz)

Frequency(MHz):				2412			Polarity:			HORIZONTAL		
No.	Frequency (MHz)	Emission Level (dBUV/m)		Limit (dBUV/m)	Margin (dB)	Antenna Height (m)	Table Angle (Degree)	Raw Value (dBUV)	Antenna Factor (dB/m)	Cable Factor (dB)	Pre-amplifier (dB)	Correction Factor (dB/m)
1	4824.00	51.22	PK	74.00	22.78	1.00	128.00	49.12	31.60	7.00	36.50	2.10
1	4824.00	45.06	AV	54.00	8.94	1.00	128.00	42.96	31.60	7.00	36.50	2.10
2	7236.00	44.12	PK	74.00	29.88	1.00	128.00	33.19	37.33	8.90	35.30	10.93
2	7236.00	39.24	AV	54.00	14.76	1.00	128.00	28.31	37.33	8.90	35.30	10.93

Frequency(MHz):				2412			Polarity:			VERTICAL		
No.	Frequency (MHz)	Emission Level (dBUV/m)		Limit (dBUV/m)	Margin (dB)	Antenna Height (m)	Table Angle (Degree)	Raw Value (dBUV)	Antenna Factor (dB/m)	Cable Factor (dB)	Pre-amplifier (dB)	Correction Factor (dB/m)
1	4824.00	51.75	PK	74.00	22.25	1.00	225.00	49.65	31.60	7.00	36.50	2.10
1	4824.00	45.18	AV	54.00	8.82	1.00	225.00	43.08	31.60	7.00	36.50	2.10
2	7236.00	43.95	PK	74.00	30.05	1.00	225.00	33.02	37.33	8.90	35.30	10.93
2	7236.00	36.86	AV	54.00	17.14	1.00	225.00	25.93	37.33	8.90	35.30	10.93

Frequency(MHz):				2437			Polarity:			HORIZONTAL		
No.	Frequency (MHz)	Emission Level (dBUV/m)		Limit (dBUV/m)	Margin (dB)	Antenna Height (m)	Table Angle (Degree)	Raw Value (dBUV)	Antenna Factor (dB/m)	Cable Factor (dB)	Pre-amplifier (dB)	Correction Factor (dB/m)
1	4874.00	50.66	PK	74.00	23.34	1.00	122.00	48.54	31.02	7.60	36.50	2.12
1	4874.00	45.72	AV	54.00	8.28	1.00	122.00	43.60	31.02	7.60	36.50	2.12
2	7311.00	44.23	PK	74.00	29.77	1.00	122.00	33.15	37.28	8.60	34.80	11.08
2	7311.00	37.95	AV	54.00	16.05	1.00	122.00	26.87	37.28	8.60	34.80	11.08

Frequency(MHz):				2437			Polarity:			VERTICAL		
No.	Frequency (MHz)	Emission Level (dBUV/m)		Limit (dBUV/m)	Margin (dB)	Antenna Height (m)	Table Angle (Degree)	Raw Value (dBUV)	Antenna Factor (dB/m)	Cable Factor (dB)	Pre-amplifier (dB)	Correction Factor (dB/m)
1	4874.00	51.85	PK	74.00	22.15	1.00	235.00	49.73	31.02	7.60	36.50	2.12
1	4874.00	45.64	AV	54.00	8.36	1.00	235.00	43.52	31.02	7.60	36.50	2.12
2	7311.00	45.37	PK	74.00	28.63	1.00	235.00	34.29	37.28	8.60	34.80	11.08
2	7311.00	37.03	AV	54.00	16.97	1.00	235.00	25.95	37.28	8.60	34.80	11.08

Frequency(MHz):				2462			Polarity:			HORIZONTAL		
No.	Frequency (MHz)	Emission Level (dBUV/m)		Limit (dBUV/m)	Margin (dB)	Antenna Height (m)	Table Angle (Degree)	Raw Value (dBUV)	Antenna Factor (dB/m)	Cable Factor (dB)	Pre-amplifier (dB)	Correction Factor (dB/m)
1	4924.00	50.78	PK	74.00	23.22	1.00	140.00	47.58	31.58	7.82	36.20	3.20
1	4924.00	44.11	AV	54.00	9.89	1.00	140.00	40.91	31.58	7.82	36.20	3.20
2	7386.00	44.59	PK	74.00	29.41	1.00	140.00	32.65	38.51	8.73	35.30	11.94
2	7386.00	37.08	AV	54.00	16.92	1.00	140.00	25.14	38.51	8.73	35.30	11.94

Frequency(MHz):				2462			Polarity:			VERTICAL		
No.	Frequency (MHz)	Emission Level (dBUV/m)		Limit (dBUV/m)	Margin (dB)	Antenna Height (m)	Table Angle (Degree)	Raw Value (dBUV)	Antenna Factor (dB/m)	Cable Factor (dB)	Pre-amplifier (dB)	Correction Factor (dB/m)
1	4924.00	52.11	PK	74.00	21.89	1.00	221.00	48.91	31.58	7.82	36.20	3.20
1	4924.00	46.64	AV	54.00	7.36	1.00	221.00	43.44	31.58	7.82	36.20	3.20
2	7386.00	44.83	PK	74.00	29.17	1.00	221.00	32.89	38.51	8.73	35.30	11.94
2	7386.00	38.84	AV	54.00	15.16	1.00	221.00	26.90	38.51	8.73	35.30	11.94



**802.11g Mode (above 1GHz)**

Frequency(MHz):				2412			Polarity:			HORIZONTAL		
No.	Frequency (MHz)	Emission Level (dBuV/m)		Limit (dBuV/m)	Margin (dB)	Antenna Height (m)	Table Angle (Degree)	Raw Value (dBuV)	Antenna Factor (dB/m)	Cable Factor (dB)	Pre-amplifier (dB)	Correction Factor (dB/m)
1	4824.00	50.57	PK	74.00	23.43	1.00	128.00	48.47	31.60	7.00	36.50	2.10
1	4824.00	42.54	AV	54.00	11.46	1.00	128.00	40.44	31.60	7.00	36.50	2.10
2	7236.00	45.71	PK	74.00	28.29	1.00	128.00	34.78	37.33	8.90	35.30	10.93
2	7236.00	34.96	AV	54.00	19.04	1.00	128.00	24.03	37.33	8.90	35.30	10.93

Frequency(MHz):				2412			Polarity:			VERTICAL		
No.	Frequency (MHz)	Emission Level (dBuV/m)		Limit (dBuV/m)	Margin (dB)	Antenna Height (m)	Table Angle (Degree)	Raw Value (dBuV)	Antenna Factor (dB/m)	Cable Factor (dB)	Pre-amplifier (dB)	Correction Factor (dB/m)
1	4824.00	51.29	PK	74.00	22.71	1.00	225.00	49.19	31.60	7.00	36.50	2.10
1	4824.00	43.70	AV	54.00	10.30	1.00	225.00	41.60	31.60	7.00	36.50	2.10
2	7236.00	45.66	PK	74.00	28.34	1.00	225.00	34.73	37.33	8.90	35.30	10.93
2	7236.00	39.12	AV	54.00	14.88	1.00	225.00	28.19	37.33	8.90	35.30	10.93

Frequency(MHz):				2437			Polarity:			HORIZONTAL		
No.	Frequency (MHz)	Emission Level (dBuV/m)		Limit (dBuV/m)	Margin (dB)	Antenna Height (m)	Table Angle (Degree)	Raw Value (dBuV)	Antenna Factor (dB/m)	Cable Factor (dB)	Pre-amplifier (dB)	Correction Factor (dB/m)
1	4874.00	50.07	PK	74.00	23.93	1.00	122.00	47.95	31.02	7.60	36.50	2.12
1	4874.00	43.03	AV	54.00	10.97	1.00	122.00	40.91	31.02	7.60	36.50	2.12
2	7311.00	45.03	PK	74.00	28.97	1.00	122.00	33.95	37.28	8.60	34.80	11.08
2	7311.00	35.55	AV	54.00	18.45	1.00	122.00	24.47	37.28	8.60	34.80	11.08

Frequency(MHz):				2437			Polarity:			VERTICAL		
No.	Frequency (MHz)	Emission Level (dBuV/m)		Limit (dBuV/m)	Margin (dB)	Antenna Height (m)	Table Angle (Degree)	Raw Value (dBuV)	Antenna Factor (dB/m)	Cable Factor (dB)	Pre-amplifier (dB)	Correction Factor (dB/m)
1	4874.00	50.35	PK	74.00	23.65	1.00	235.00	48.23	31.02	7.60	36.50	2.12
1	4874.00	41.77	AV	54.00	12.23	1.00	235.00	39.65	31.02	7.60	36.50	2.12
2	7311.00	45.42	PK	74.00	28.58	1.00	235.00	34.34	37.28	8.60	34.80	11.08
2	7311.00	37.70	AV	54.00	16.30	1.00	235.00	26.62	37.28	8.60	34.80	11.08

Frequency(MHz):				2462			Polarity:			HORIZONTAL		
No.	Frequency (MHz)	Emission Level (dBuV/m)		Limit (dBuV/m)	Margin (dB)	Antenna Height (m)	Table Angle (Degree)	Raw Value (dBuV)	Antenna Factor (dB/m)	Cable Factor (dB)	Pre-amplifier (dB)	Correction Factor (dB/m)
1	4924.00	51.21	PK	74.00	22.79	1.00	235.00	48.01	31.58	7.82	36.20	3.20
1	4924.00	42.08	AV	54.00	11.92	1.00	235.00	38.88	31.58	7.82	36.20	3.20
2	7386.00	46.69	PK	74.00	27.31	1.00	235.00	34.75	38.51	8.73	35.30	11.94
2	7386.00	35.42	AV	54.00	18.58	1.00	235.00	23.48	38.51	8.73	35.30	11.94

Frequency(MHz):				2462			Polarity:			VERTICAL		
No.	Frequency (MHz)	Emission Level (dBuV/m)		Limit (dBuV/m)	Margin (dB)	Antenna Height (m)	Table Angle (Degree)	Raw Value (dBuV)	Antenna Factor (dB/m)	Cable Factor (dB)	Pre-amplifier (dB)	Correction Factor (dB/m)
1	4924.00	50.84	PK	74.00	23.16	1.00	221.00	47.64	31.58	7.82	36.20	3.20
1	4924.00	41.98	AV	54.00	12.02	1.00	221.00	38.78	31.58	7.82	36.20	3.20
2	7386.00	45.93	PK	74.00	28.07	1.00	221.00	33.99	38.51	8.73	35.30	11.94
2	7386.00	36.69	AV	54.00	17.31	1.00	221.00	24.75	38.51	8.73	35.30	11.94

**802.11n20 Mode (above 1GHz)**

Frequency(MHz):				2412			Polarity:			HORIZONTAL		
No.	Frequency (MHz)	Emission Level (dBuV/m)		Limit (dBuV/m)	Margin (dB)	Antenna Height (m)	Table Angle (Degree)	Raw Value (dBuV)	Antenna Factor (dB/m)	Cable Factor (dB)	Pre-amplifier (dB)	Correction Factor (dB/m)
1	4824.00	50.17	PK	74.00	23.83	1.00	116.00	48.07	31.60	7.00	36.50	2.10
1	4824.00	41.26	AV	54.00	12.74	1.00	116.00	39.16	31.60	7.00	36.50	2.10
2	7236.00	43.89	PK	74.00	30.11	1.00	116.00	32.96	37.33	8.90	35.30	10.93
2	7236.00	33.80	AV	54.00	20.20	1.00	116.00	22.87	37.33	8.90	35.30	10.93

Frequency(MHz):				2412			Polarity:			VERTICAL		
No.	Frequency (MHz)	Emission Level (dBuV/m)		Limit (dBuV/m)	Margin (dB)	Antenna Height (m)	Table Angle (Degree)	Raw Value (dBuV)	Antenna Factor (dB/m)	Cable Factor (dB)	Pre-amplifier (dB)	Correction Factor (dB/m)
1	4824.00	51.10	PK	74.00	22.90	1.00	210.00	49.00	31.60	7.00	36.50	2.10
1	4824.00	41.46	AV	54.00	12.54	1.00	210.00	39.36	31.60	7.00	36.50	2.10
2	7236.00	45.50	PK	74.00	28.50	1.00	210.00	34.57	37.33	8.90	35.30	10.93
2	7236.00	37.65	AV	54.00	16.35	1.00	210.00	26.72	37.33	8.90	35.30	10.93

Frequency(MHz):				2437			Polarity:			HORIZONTAL		
No.	Frequency (MHz)	Emission Level (dBuV/m)		Limit (dBuV/m)	Margin (dB)	Antenna Height (m)	Table Angle (Degree)	Raw Value (dBuV)	Antenna Factor (dB/m)	Cable Factor (dB)	Pre-amplifier (dB)	Correction Factor (dB/m)
1	4874.00	48.58	PK	74.00	25.42	1.00	116.00	46.46	31.02	7.60	36.50	2.12
1	4874.00	40.95	AV	54.00	13.05	1.00	116.00	38.83	31.02	7.60	36.50	2.12
2	7311.00	43.86	PK	74.00	30.14	1.00	116.00	32.78	37.28	8.60	34.80	11.08
2	7311.00	34.10	AV	54.00	19.90	1.00	116.00	23.02	37.28	8.60	34.80	11.08

Frequency(MHz):				2437			Polarity:			VERTICAL		
No.	Frequency (MHz)	Emission Level (dBuV/m)		Limit (dBuV/m)	Margin (dB)	Antenna Height (m)	Table Angle (Degree)	Raw Value (dBuV)	Antenna Factor (dB/m)	Cable Factor (dB)	Pre-amplifier (dB)	Correction Factor (dB/m)
1	4874.00	49.04	PK	74.00	24.96	1.00	240.00	46.92	31.02	7.60	36.50	2.12
1	4874.00	42.58	AV	54.00	11.42	1.00	240.00	40.46	31.02	7.60	36.50	2.12
2	7311.00	44.91	PK	74.00	29.09	1.00	240.00	33.83	37.28	8.60	34.80	11.08
2	7311.00	36.45	AV	54.00	17.55	1.00	240.00	25.37	37.28	8.60	34.80	11.08

Frequency(MHz):				2462			Polarity:			HORIZONTAL		
No.	Frequency (MHz)	Emission Level (dBuV/m)		Limit (dBuV/m)	Margin (dB)	Antenna Height (m)	Table Angle (Degree)	Raw Value (dBuV)	Antenna Factor (dB/m)	Cable Factor (dB)	Pre-amplifier (dB)	Correction Factor (dB/m)
1	4924.00	50.93	PK	74.00	23.07	1.00	245.00	47.73	31.58	7.82	36.20	3.20
1	4924.00	43.03	AV	54.00	10.97	1.00	245.00	39.83	31.58	7.82	36.20	3.20
2	7386.00	44.87	PK	74.00	29.13	1.00	245.00	32.93	38.51	8.73	35.30	11.94
2	7386.00	35.81	AV	54.00	18.19	1.00	245.00	23.87	38.51	8.73	35.30	11.94

Frequency(MHz):				2462			Polarity:			VERTICAL		
No.	Frequency (MHz)	Emission Level (dBuV/m)		Limit (dBuV/m)	Margin (dB)	Antenna Height (m)	Table Angle (Degree)	Raw Value (dBuV)	Antenna Factor (dB/m)	Cable Factor (dB)	Pre-amplifier (dB)	Correction Factor (dB/m)
1	4924.00	50.53	PK	74.00	23.47	1.00	215.00	47.33	31.58	7.82	36.20	3.20
1	4924.00	41.71	AV	54.00	12.29	1.00	215.00	38.51	31.58	7.82	36.20	3.20
2	7386.00	45.50	PK	74.00	28.50	1.00	215.00	33.56	38.51	8.73	35.30	11.94
2	7386.00	36.74	AV	54.00	17.26	1.00	215.00	24.80	38.51	8.73	35.30	11.94

**802.11n40 Mode (above 1GHz)**

Frequency(MHz):			2422			Polarity:			HORIZONTAL		
No.	Frequency (MHz)	Emission Level (dBuV/m)	Limit (dBuV/m)	Margin (dB)	Antenna Height (m)	Table Angle (Degree)	Raw Value (dBuV)	Antenna Factor (dB/m)	Cable Factor (dB)	Pre-amplifier (dB)	Correction Factor (dB/m)
1	4844.00	49.86 PK	74.00	24.14	1.00	138.00	47.76	31.60	7.00	36.50	2.10
1	4844.00	39.42 AV	54.00	14.58	1.00	138.00	37.32	31.60	7.00	36.50	2.10
2	7266.00	42.05 PK	74.00	31.95	1.00	138.00	31.12	37.33	8.90	35.30	10.93
2	7266.00	35.88 AV	54.00	18.12	1.00	138.00	24.95	37.33	8.90	35.30	10.93

Frequency(MHz):			2422			Polarity:			VERTICAL		
No.	Frequency (MHz)	Emission Level (dBuV/m)	Limit (dBuV/m)	Margin (dB)	Antenna Height (m)	Table Angle (Degree)	Raw Value (dBuV)	Antenna Factor (dB/m)	Cable Factor (dB)	Pre-amplifier (dB)	Correction Factor (dB/m)
1	4844.00	48.39 PK	74.00	25.61	1.00	230.00	46.29	31.60	7.00	36.50	2.10
1	4844.00	39.82 AV	54.00	14.18	1.00	230.00	37.72	31.60	7.00	36.50	2.10
2	7266.00	44.52 PK	74.00	29.48	1.00	230.00	33.59	37.33	8.90	35.30	10.93
2	7266.00	35.97 AV	54.00	18.03	1.00	230.00	25.04	37.33	8.90	35.30	10.93

Frequency(MHz):			2437			Polarity:			HORIZONTAL		
No.	Frequency (MHz)	Emission Level (dBuV/m)	Limit (dBuV/m)	Margin (dB)	Antenna Height (m)	Table Angle (Degree)	Raw Value (dBuV)	Antenna Factor (dB/m)	Cable Factor (dB)	Pre-amplifier (dB)	Correction Factor (dB/m)
1	4874.00	49.07 PK	74.00	24.93	1.00	118.00	46.95	31.02	7.60	36.50	2.12
1	4874.00	38.62 AV	54.00	15.38	1.00	118.00	36.50	31.02	7.60	36.50	2.12
2	7311.00	42.04 PK	74.00	31.96	1.00	118.00	30.96	37.28	8.60	34.80	11.08
2	7311.00	35.27 AV	54.00	18.73	1.00	118.00	24.19	37.28	8.60	34.80	11.08

Frequency(MHz):			2437			Polarity:			VERTICAL		
No.	Frequency (MHz)	Emission Level (dBuV/m)	Limit (dBuV/m)	Margin (dB)	Antenna Height (m)	Table Angle (Degree)	Raw Value (dBuV)	Antenna Factor (dB/m)	Cable Factor (dB)	Pre-amplifier (dB)	Correction Factor (dB/m)
1	4874.00	49.08 PK	74.00	24.92	1.00	250.00	46.96	31.02	7.60	36.50	2.12
1	4874.00	41.70 AV	54.00	12.30	1.00	250.00	39.58	31.02	7.60	36.50	2.12
2	7311.00	44.46 PK	74.00	29.54	1.00	250.00	33.38	37.28	8.60	34.80	11.08
2	7311.00	36.52 AV	54.00	17.48	1.00	250.00	25.44	37.28	8.60	34.80	11.08

Frequency(MHz):			2452			Polarity:			HORIZONTAL		
No.	Frequency (MHz)	Emission Level (dBuV/m)	Limit (dBuV/m)	Margin (dB)	Antenna Height (m)	Table Angle (Degree)	Raw Value (dBuV)	Antenna Factor (dB/m)	Cable Factor (dB)	Pre-amplifier (dB)	Correction Factor (dB/m)
1	4904.00	48.36 PK	74.00	25.64	1.00	235.00	45.16	31.58	7.82	36.20	3.20
1	4904.00	41.74 AV	54.00	12.26	1.00	235.00	38.54	31.58	7.82	36.20	3.20
2	7356.00	42.68 PK	74.00	31.32	1.00	235.00	30.74	38.51	8.73	35.30	11.94
2	7356.00	34.55 AV	54.00	19.45	1.00	235.00	22.61	38.51	8.73	35.30	11.94

Frequency(MHz):			2452			Polarity:			VERTICAL		
No.	Frequency (MHz)	Emission Level (dBuV/m)	Limit (dBuV/m)	Margin (dB)	Antenna Height (m)	Table Angle (Degree)	Raw Value (dBuV)	Antenna Factor (dB/m)	Cable Factor (dB)	Pre-amplifier (dB)	Correction Factor (dB/m)
1	4904.00	48.72 PK	74.00	25.28	1.00	221.00	45.52	31.58	7.82	36.20	3.20
1	4904.00	41.53 AV	54.00	12.47	1.00	221.00	38.33	31.58	7.82	36.20	3.20
2	7356.00	45.91 PK	74.00	28.09	1.00	221.00	33.97	38.51	8.73	35.30	11.94
2	7356.00	35.33 AV	54.00	18.67	1.00	221.00	23.39	38.51	8.73	35.30	11.94

## 2.5. Maximum Conducted Output Power

### Limit

30dBm for digital modulation systems.

### Test Procedure

1. Remove the antenna from the EUT and then connect a low loss RF cable from the antenna port to the Power Meter.
2. Ensure EUT transmitting with a duty cycle  $\geq 98\%$ .
3. Record the value of Power Meter.

### Test Configuration

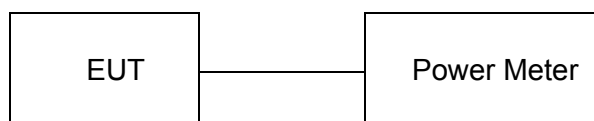

### Test Results

WIFI				
Type	Channel	Output power PK(dBm)	Limit (dBm)	Result
802.11b	01	11.13	30.00	Pass
	06	11.41		
	11	10.46		
802.11g	01	12.45	30.00	Pass
	06	12.73		
	11	11.82		
802.11n(H20)	01	11.81	30.00	Pass
	06	11.96		
	11	11.25		
802.11n(H40)	03	11.61	30.00	Pass
	06	11.64		
	09	11.51		

Note: 1.The test results including the cable lose.

## 2.6. Power Spectral Density

### Limit

For digitally modulated systems, the power spectral density conducted from the intentional radiator to the antenna shall not be greater than 8 dBm in any 3 kHz band during any time interval of continuous transmission.

### Test Procedure

- This procedure shall be used if maximum peak conducted output power was used to demonstrate compliance to the output power limit.
  1. Set analyzer center frequency to DTS channel center frequency.
  2. Set the span to 1.5 times the DTS bandwidth.
  3. Set the RBW to:  $3\text{ kHz} \leq \text{RBW} \leq 100\text{ kHz}$ .
  4. Set the VBW  $\geq 3 \times \text{RBW}$ .
  5. Detector = peak.
  6. Sweep time = auto couple.
  7. Trace mode = max hold.
  8. Allow trace to fully stabilize.
  9. Use the peak marker function to determine the maximum amplitude level within the RBW.
  10. If measured value exceeds limit, reduce RBW (no less than 3 kHz) and repeat

### Test Configuration

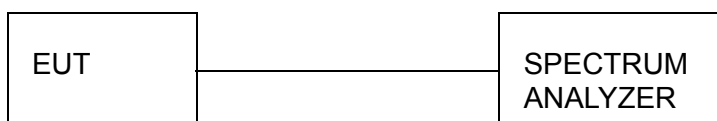

### Test Results

WIFI				
Type	Channel	Power Spectral Density (dBm/30KHz)	Limit (dBm/3KHz)	Result
802.11b	01	-6.750	8.00	Pass
	06	-6.560		
	11	-7.540		
802.11g	01	-10.480	8.00	Pass
	06	-11.100		
	11	-11.950		
802.11n(HT20)	01	-12.030	8.00	Pass
	06	-11.780		
	11	-12.810		
802.11n(HT40)	01	-15.610	8.00	Pass
	06	-14.910		
	11	-15.750		

Test plot as follows:

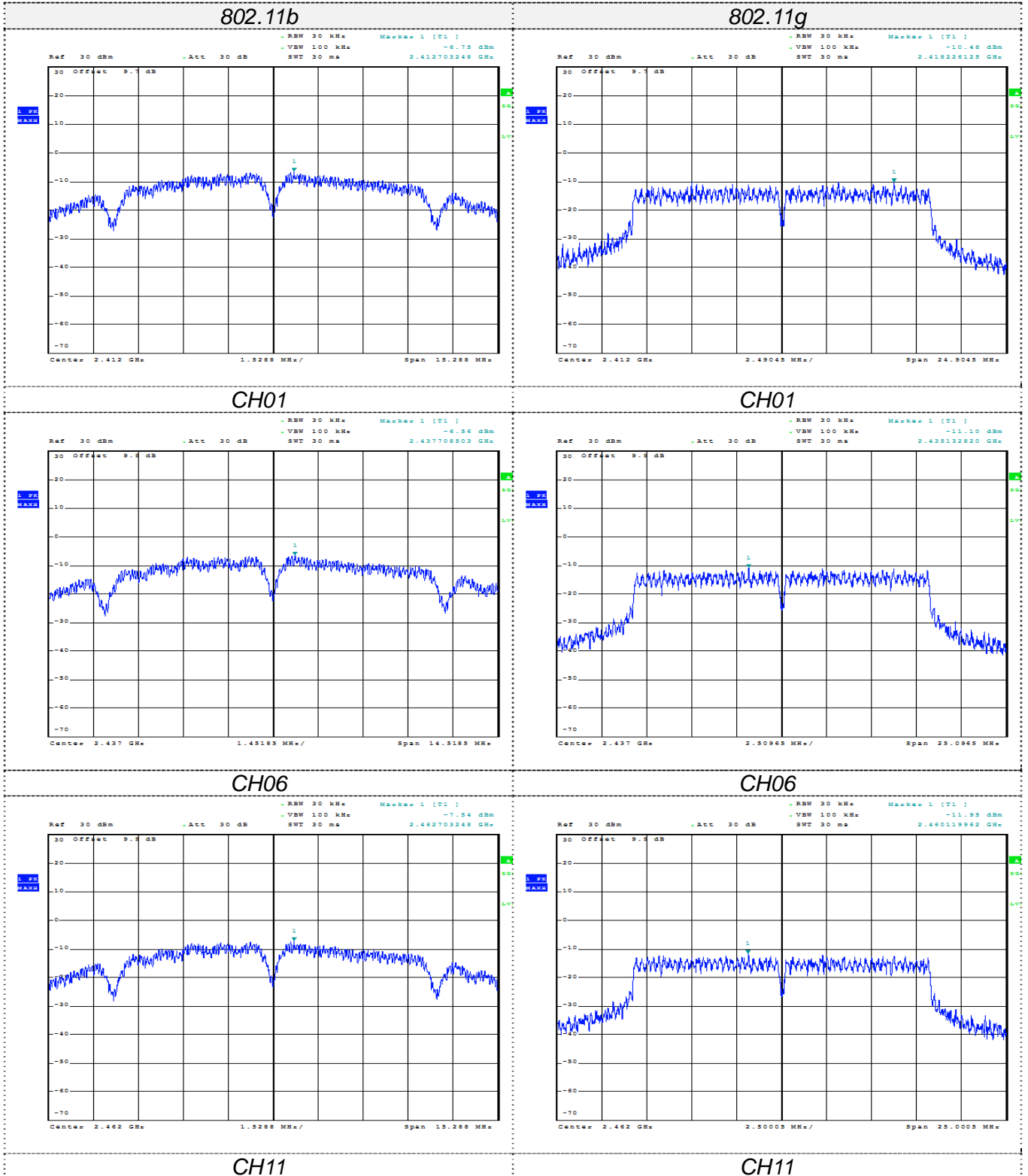

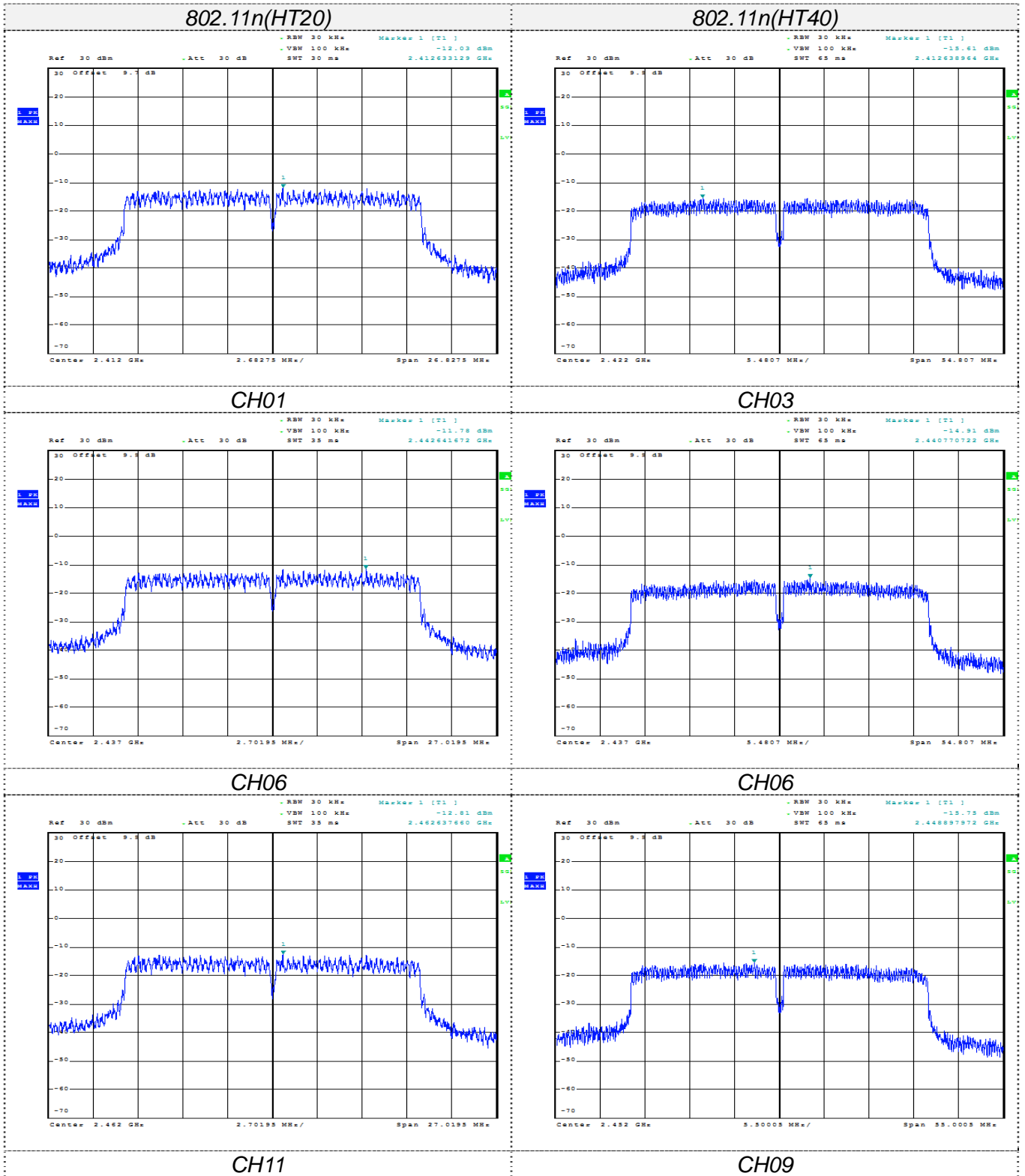

## 2.7. 6dB Bandwidth

### Limit

For digital modulation systems, the minimum 6 dB bandwidth shall be at least 500 kHz

### Test Procedure

1. The transmitter output was connected to the spectrum analyzer.
2. Set SA as follow:
  - a) RBW: 100 kHz.
  - b) VBW:  $\geq 3 \times$  RBW.
  - c) Detector: Peak.
  - d) Trace mode: max hold.
  - e) Sweep: auto couple.
3. Allow the trace to stabilize.
4. Measure the maximum width of the emission that is constrained by the frequencies associated with the two outermost amplitude points (upper and lower frequencies) that are attenuated by 6 dB relative to the maximum level measured in the fundamental emission.

### Test Configuration

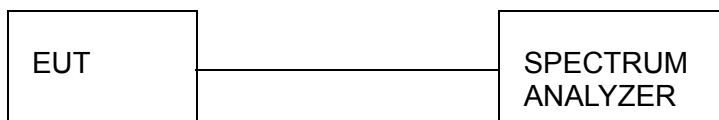

### Test Results

WIFI				
Type	Channel	6dB Bandwidth (MHz)	Limit (KHz)	Result
802.11b	01	10.128	≥500	Pass
	06	9.936		
	11	10.192		
802.11g	01	16.602	≥500	Pass
	06	16.602		
	11	16.538		
802.11n(HT20)	01	17.885	≥500	Pass
	06	17.885		
	11	17.885		
802.11n(HT40)	03	36.410	≥500	Pass
	06	36.666		
	09	36.538		

Test plot as follows:



802.11b

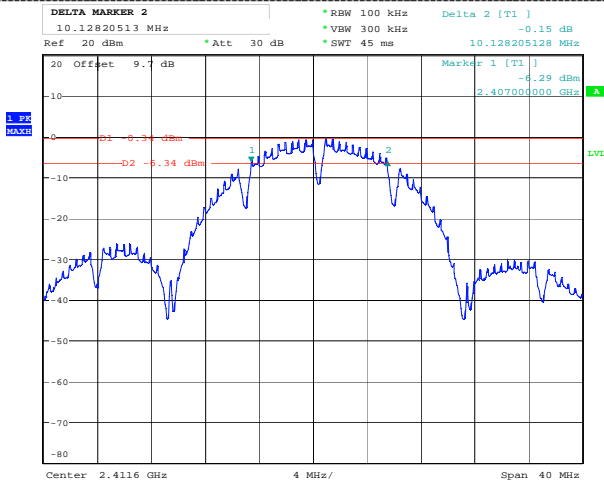

802.11g

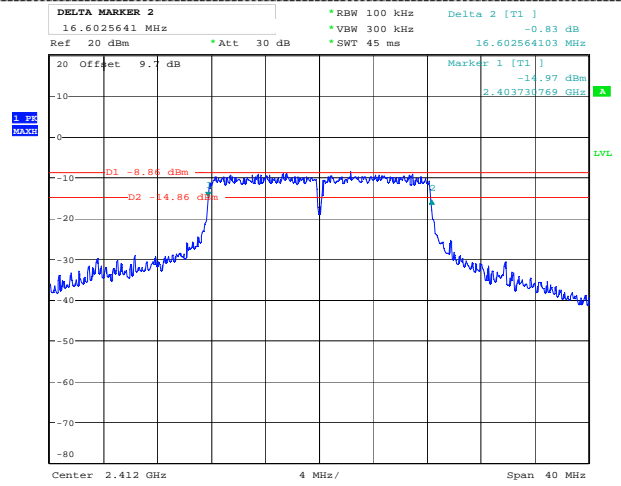

CH01

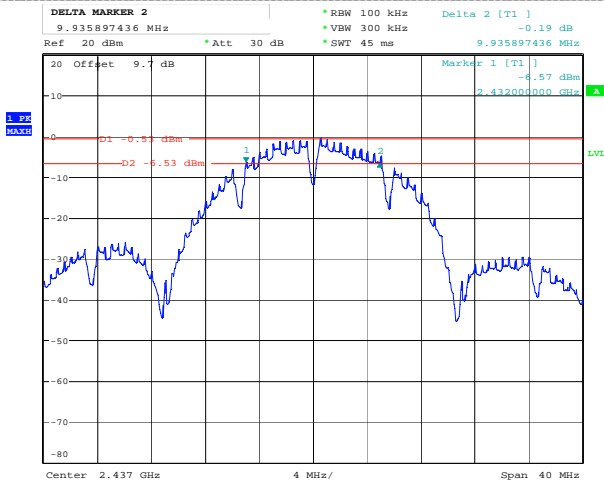

CH01

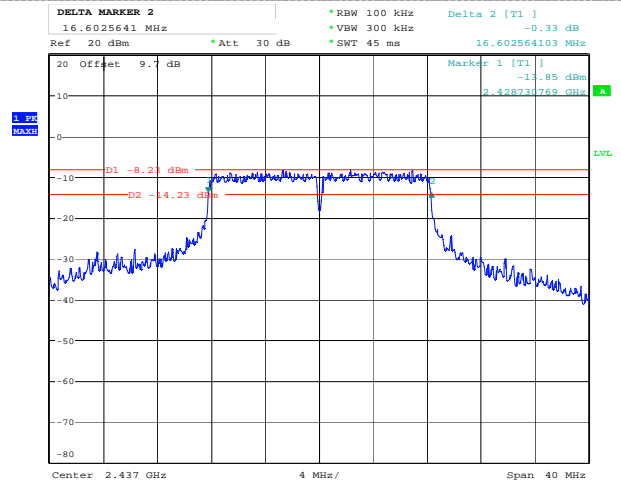

CH06

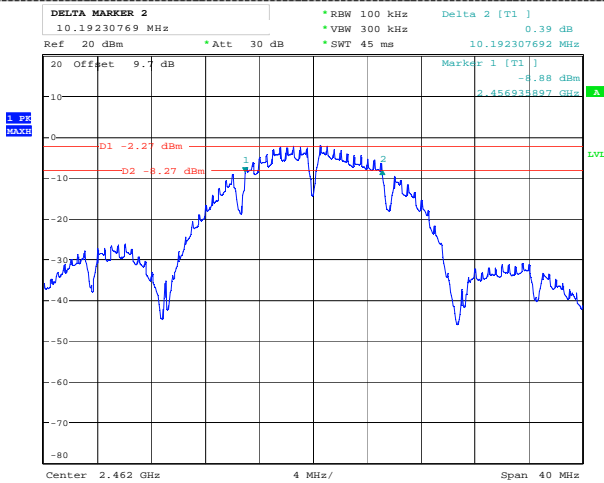

CH06

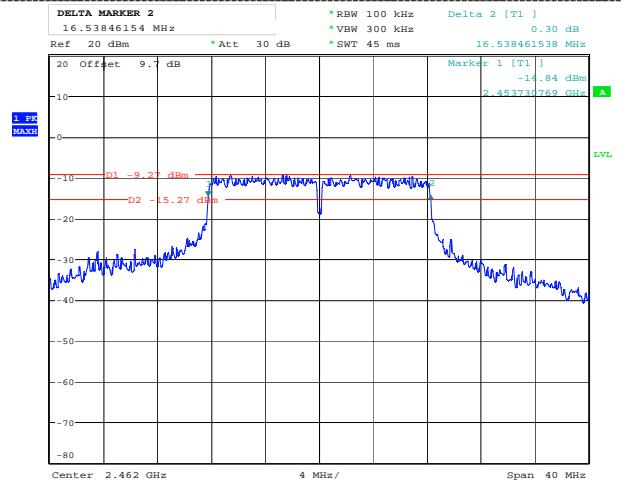

CH11

CH11

802.11n(HT20)

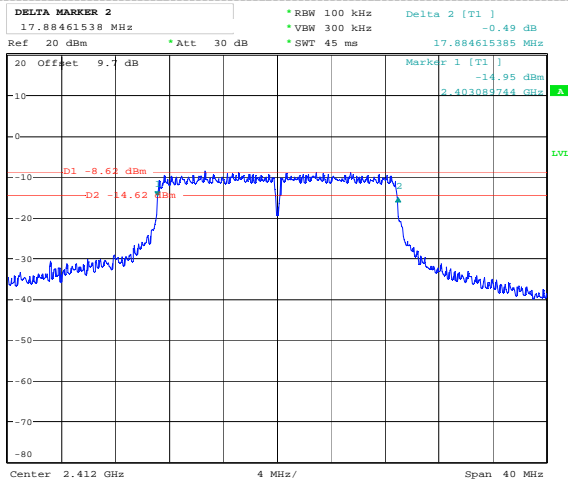

802.11n(HT40)

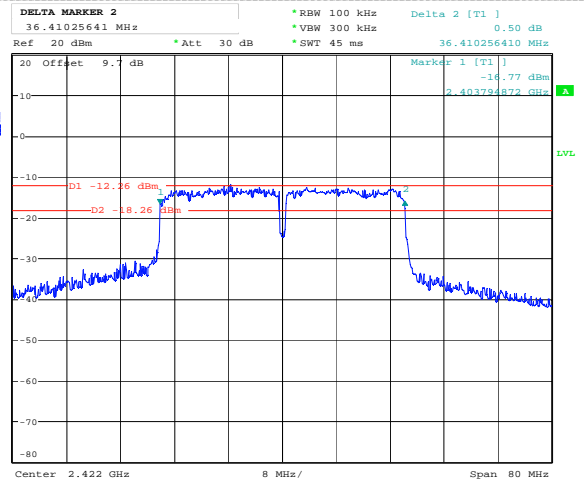

CH01

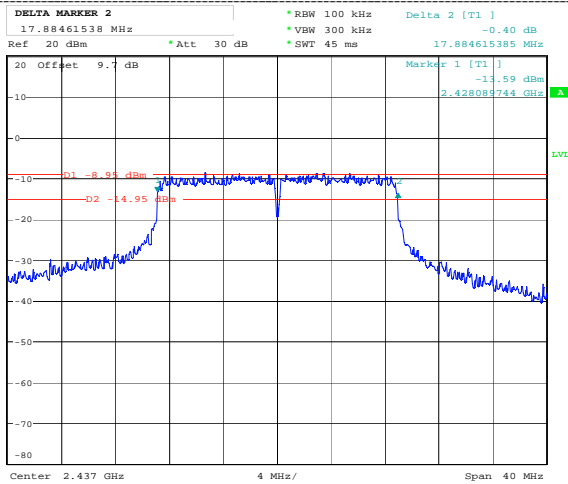

CH03

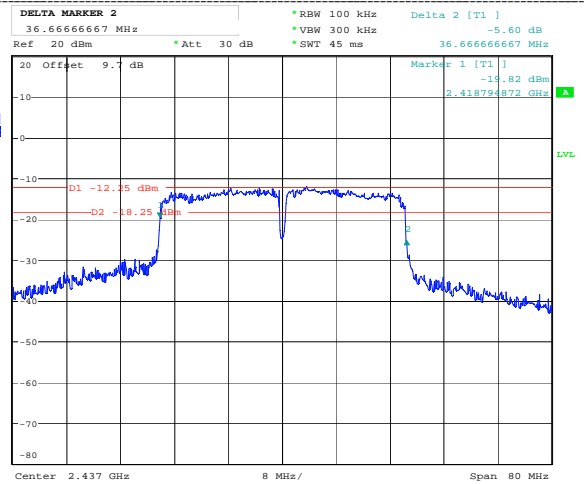

CH06

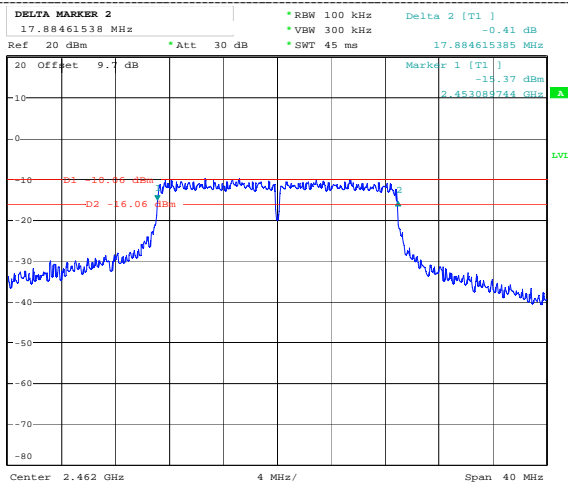

CH06

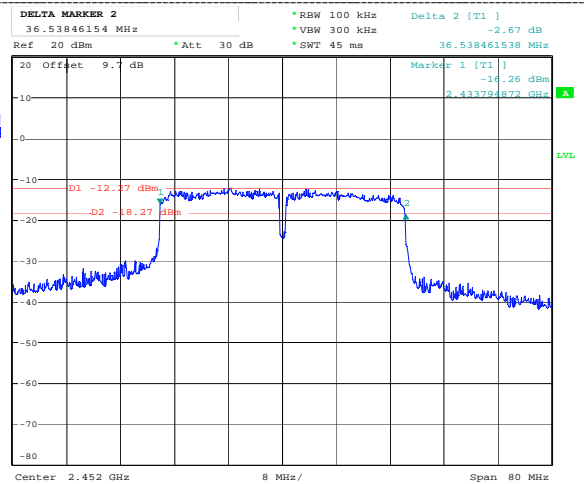

CH11



CH09



## 2.8. Band Edge Compliance of RF Emission

### Limit

In any 100 kHz bandwidth outside the frequency band in which the spread spectrum or digitally modulated intentional radiator is operating, the radio frequency power that is produced by the intentional radiator shall be at least 20 dB below that in the 100 kHz bandwidth within the band that contains the highest level of the desired power, based on either an RF conducted or a radiated measurement, provided the transmitter demonstrates compliance with the peak conducted power limits. If the transmitter complies with the conducted power limits based on the use of RMS averaging over a time interval, as permitted under paragraph (b)(3) of this section, the attenuation required under this paragraph shall be 30 dB instead of 20 dB. Attenuation below the general limits specified in §15.209(a) is not required. In addition, radiated emissions which fall in the restricted bands, as defined in §15.205(a), must also comply with the radiated emission limits specified in §15.209(a) (see §15.205(c)).

Radiated emissions which fall in the restricted bands, as defined in § 15.205(a), must also comply with the radiated emission limits specified in § 15.209(a)

### Test Procedure

#### **Test Procedure for conducted method**

- Use this procedure when the maximum (average) conducted output power was used to demonstrate compliance to the output power limit.
  1. Remove the antenna from the EUT and then connect to a low loss RF cable from the antenna port to a spectrum analyzer
  2. Turn on the EUT and make it operate in transmitting mode. Then set it to Low Channel and High Channel within its operating range, and make sure the instrument is operated in its linear range.
    1. Set spectrum analyzer RBW =100 kHz, VBW=300 kHz, Detector=peak, Sweep time=Auto, trace=maxhold
    3. Marker the highest point which fall into restricted frequency bands
    4. Repeat above procedures until all measured frequencies were complete.

#### **Test Procedure for radiated method**

1. The EUT was placed on the top of a rotating table 0.8 meters above the ground at a 3 meter anechoic chamber. The table was rotated 360 degrees to determine the position of the highest radiation.
2. The EUT was set 3 meters away from the interference receiving antenna, which was mounted on the top of a variable height antenna tower.
3. The antenna height is varied from one meter to four meters above the ground to determine the maximum value of the field strength. Both horizontal and vertical polarizations of the antenna are set to make the measurement.
4. For each suspected emission, the EUT was arranged to its worst case and then the antenna was tuned to heights from 1 meter to 4 meters and the rotatable table was turned from 0 degrees to 360 degrees to find the maximum reading.
5. The test-receiver system was set to Peak Detect Function and Specified Bandwidth with Maximum Hold Mode.
6. Place a marker at the end of the restricted band closest to the transmit frequency to show compliance. Also measure any emissions in the restricted bands. Save the spectrum analyzer plot. Repeat for each power and modulation for lowest and highest channel
7. Test the EUT in the lowest channel, the highest channel
8. The radiation measurements are performed in X, Y, Z axis positioning. And found the X axis positioning which it is worse case, only the test worst case mode is recorded in the report.
9. Repeat above procedures until all frequencies measured was complete.

**Test Results**

**A. Conducted measurements**

802.11b			
Frequency (MHz)	Delta Peak to Band emission (dBc)	Limit (dBc)	Verdict
2383.484	39.959	20	PASS
2488.023	39.388	20	PASS

	
2412	2462

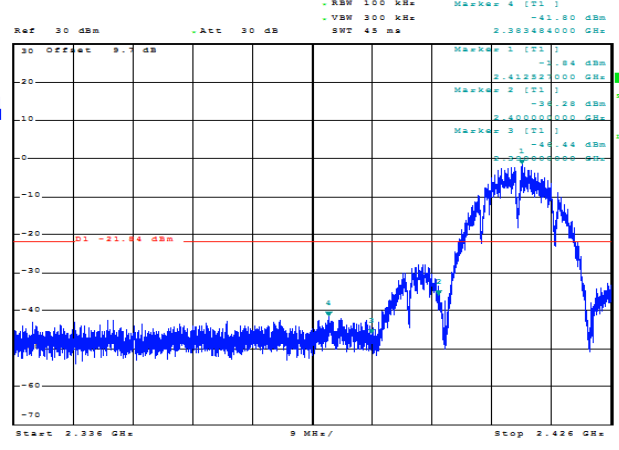
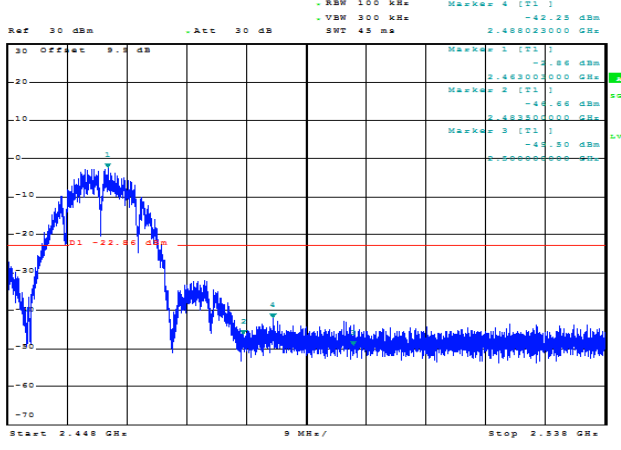
802.11g			
Frequency (MHz)	Delta Peak to Band emission (dBc)	Limit (dBc)	Verdict
2388.884	30.432	20	PASS
2484.207	32.818	20	PASS

	
2412	2462

802.11n20			
Frequency (MHz)	Delta Peak to Band emission (dBc)	Limit (dBc)	Verdict
2388.749	31.109	20	PASS
2488.239	31.744	20	PASS

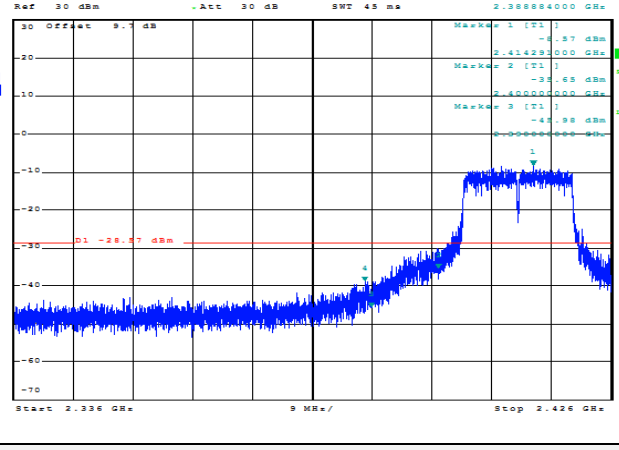
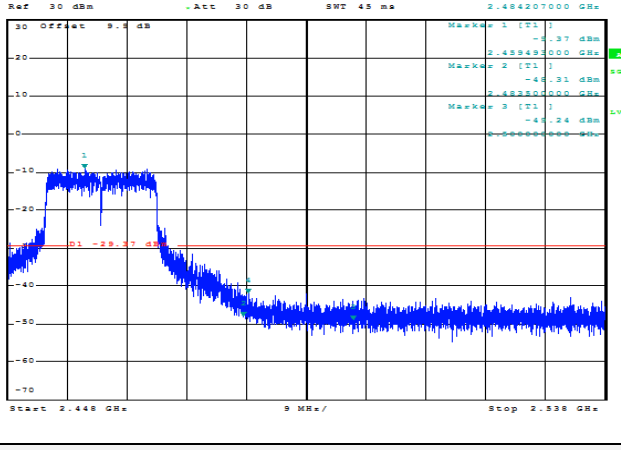
 <p>2412</p>	 <p>2462</p>
---	--

802.11n40			
Frequency (MHz)	Delta Peak to Band emission (dBc)	Limit (dBc)	Verdict
2389.523	23.103	20	PASS
2484.378	26.533	20	PASS

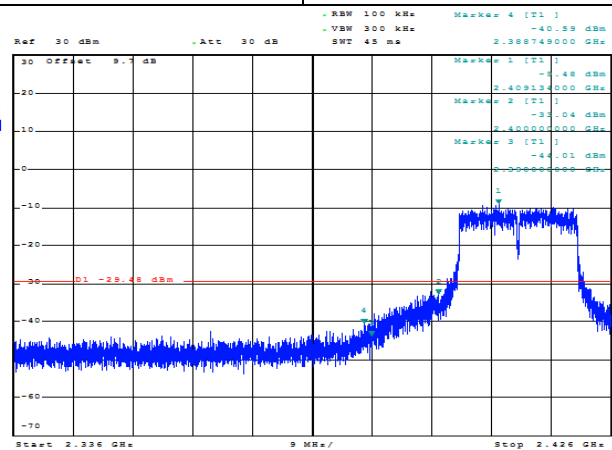
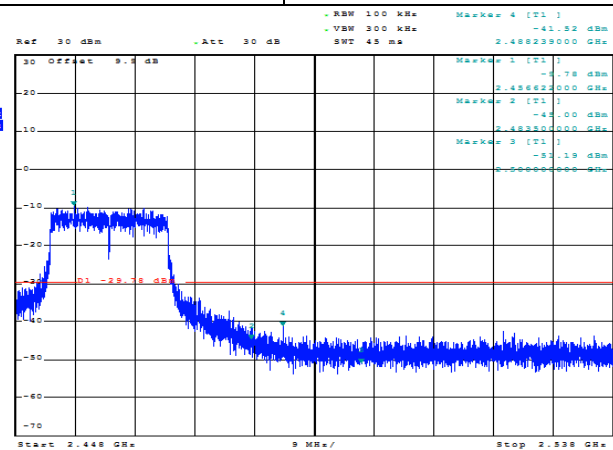
 <p>2422</p>	 <p>2452</p>
---	--

**B. Radiated measurements**

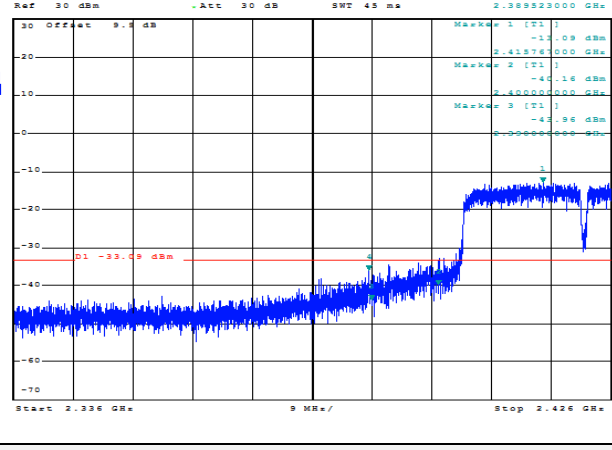
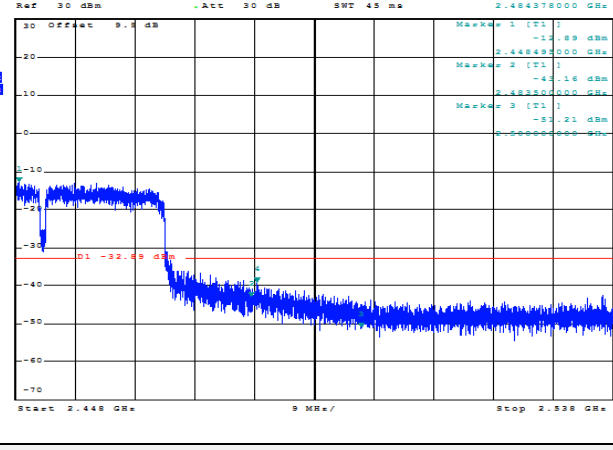
**802.11b**

Frequency(MHz):			2412			Polarity:			HORIZONTAL		
Frequency (MHz)	Emission Level (dBuV/m)		Limit (dBuV/m)	Margin (dB)	Antenna Height (m)	Table Angle (Degree)	Raw Value (dBuV)	Antenna Factor (dB/m)	Cable Factor (dB)	Pre-amplifier (dB)	Correction Factor (dB/m)
2390.00	57.25	PK	74.00	16.75	1.00	263	62.56	27.49	3.32	36.12	-5.31
2390.00	47.91	AV	54.00	6.09	1.00	263	53.22	27.49	3.32	36.12	-5.31
Frequency(MHz):			2412			Polarity:			VERTICAL		
Frequency (MHz)	Emission Level (dBuV/m)		Limit (dBuV/m)	Margin (dB)	Antenna Height (m)	Table Angle (Degree)	Raw Value (dBuV)	Antenna Factor (dB/m)	Cable Factor (dB)	Pre-amplifier (dB)	Correction Factor (dB/m)
2390.00	55.17	PK	74.00	18.83	1.00	172	60.48	27.49	3.32	36.12	-5.31
2390.00	45.43	AV	54.00	8.57	1.00	172	50.74	27.49	3.32	36.12	-5.31
Frequency(MHz):			2462			Polarity:			HORIZONTAL		
Frequency (MHz)	Emission Level (dBuV/m)		Limit (dBuV/m)	Margin (dB)	Antenna Height (m)	Table Angle (Degree)	Raw Value (dBuV)	Antenna Factor (dB/m)	Cable Factor (dB)	Pre-amplifier (dB)	Correction Factor (dB/m)
2483.50	57.52	PK	74.00	16.48	1.00	268	63.24	27.45	3.38	36.55	-5.72
2483.50	46.43	AV	54.00	7.57	1.00	268	52.15	27.45	3.38	36.55	-5.72
Frequency(MHz):			2462			Polarity:			VERTICAL		
Frequency (MHz)	Emission Level (dBuV/m)		Limit (dBuV/m)	Margin (dB)	Antenna Height (m)	Table Angle (Degree)	Raw Value (dBuV)	Antenna Factor (dB/m)	Cable Factor (dB)	Pre-amplifier (dB)	Correction Factor (dB/m)
2483.50	57.01	PK	74.00	16.99	1.00	162	62.73	27.45	3.38	36.55	-5.72
2483.50	47.39	AV	54.00	6.61	1.00	162	53.11	27.45	3.38	36.55	-5.72

**802.11g**

Frequency(MHz):			2412			Polarity:			HORIZONTAL		
Frequency (MHz)	Emission Level (dBuV/m)		Limit (dBuV/m)	Margin (dB)	Antenna Height (m)	Table Angle (Degree)	Raw Value (dBuV)	Antenna Factor (dB/m)	Cable Factor (dB)	Pre-amplifier (dB)	Correction Factor (dB/m)
2390.00	55.27	PK	74.00	18.73	1.00	258	60.58	27.49	3.32	36.12	-5.31
2390.00	46.36	AV	54.00	7.64	1.00	258	51.67	27.49	3.32	36.12	-5.31
Frequency(MHz):			2412			Polarity:			VERTICAL		
Frequency (MHz)	Emission Level (dBuV/m)		Limit (dBuV/m)	Margin (dB)	Antenna Height (m)	Table Angle (Degree)	Raw Value (dBuV)	Antenna Factor (dB/m)	Cable Factor (dB)	Pre-amplifier (dB)	Correction Factor (dB/m)
2390.00	56.18	PK	74.00	17.82	1.00	167	61.49	27.49	3.32	36.12	-5.31
2390.00	45.31	AV	54.00	8.69	1.00	167	50.62	27.49	3.32	36.12	-5.31
Frequency(MHz):			2462			Polarity:			HORIZONTAL		
Frequency (MHz)	Emission Level (dBuV/m)		Limit (dBuV/m)	Margin (dB)	Antenna Height (m)	Table Angle (Degree)	Raw Value (dBuV)	Antenna Factor (dB/m)	Cable Factor (dB)	Pre-amplifier (dB)	Correction Factor (dB/m)
2483.50	56.43	PK	74.00	17.57	1.00	268	62.15	27.45	3.38	36.55	-5.72
2483.50	45.06	AV	54.00	8.94	1.00	268	50.78	27.45	3.38	36.55	-5.72
Frequency(MHz):			2462			Polarity:			VERTICAL		
Frequency (MHz)	Emission Level (dBuV/m)		Limit (dBuV/m)	Margin (dB)	Antenna Height (m)	Table Angle (Degree)	Raw Value (dBuV)	Antenna Factor (dB/m)	Cable Factor (dB)	Pre-amplifier (dB)	Correction Factor (dB/m)
2483.50	57.15	PK	74.00	16.85	1.00	182	62.87	27.45	3.38	36.55	-5.72
2483.50	45.41	AV	54.00	8.59	1.00	182	51.13	27.45	3.38	36.55	-5.72

**802.11n20**

Frequency(MHz):			2412			Polarity:			HORIZONTAL		
Frequency (MHz)	Emission Level (dBuV/m)		Limit (dBuV/m)	Margin (dB)	Antenna Height (m)	Table Angle (Degree)	Raw Value (dBuV)	Antenna Factor (dB/m)	Cable Factor (dB)	Pre-amplifier (dB)	Correction Factor (dB/m)
2390.00	56.00	PK	74.00	18.00	1.00	283	61.31	27.49	3.32	36.12	-5.31
2390.00	45.21	AV	54.00	8.79	1.00	283	50.52	27.49	3.32	36.12	-5.31
Frequency(MHz):			2412			Polarity:			VERTICAL		
Frequency (MHz)	Emission Level (dBuV/m)		Limit (dBuV/m)	Margin (dB)	Antenna Height (m)	Table Angle (Degree)	Raw Value (dBuV)	Antenna Factor (dB/m)	Cable Factor (dB)	Pre-amplifier (dB)	Correction Factor (dB/m)
2390.00	55.57	PK	74.00	18.43	1.00	184	60.88	27.49	3.32	36.12	-5.31
2390.00	45.25	AV	54.00	8.75	1.00	184	50.56	27.49	3.32	36.12	-5.31
Frequency(MHz):			2462			Polarity:			HORIZONTAL		
Frequency (MHz)	Emission Level (dBuV/m)		Limit (dBuV/m)	Margin (dB)	Antenna Height (m)	Table Angle (Degree)	Raw Value (dBuV)	Antenna Factor (dB/m)	Cable Factor (dB)	Pre-amplifier (dB)	Correction Factor (dB/m)
2483.50	55.66	PK	74.00	18.34	1.00	278	61.38	27.45	3.38	36.55	-5.72
2483.50	46.49	AV	54.00	7.51	1.00	278	52.21	27.45	3.38	36.55	-5.72
Frequency(MHz):			2462			Polarity:			VERTICAL		
Frequency (MHz)	Emission Level (dBuV/m)		Limit (dBuV/m)	Margin (dB)	Antenna Height (m)	Table Angle (Degree)	Raw Value (dBuV)	Antenna Factor (dB/m)	Cable Factor (dB)	Pre-amplifier (dB)	Correction Factor (dB/m)
2483.50	56.29	PK	74.00	17.71	1.00	192	62.01	27.45	3.38	36.55	-5.72
2483.50	46.91	AV	54.00	7.09	1.00	192	52.63	27.45	3.38	36.55	-5.72

**802.11n40**

Frequency(MHz):			2422			Polarity:			HORIZONTAL		
Frequency (MHz)	Emission Level (dBuV/m)		Limit (dBuV/m)	Margin (dB)	Antenna Height (m)	Table Angle (Degree)	Raw Value (dBuV)	Antenna Factor (dB/m)	Cable Factor (dB)	Pre-amplifier (dB)	Correction Factor (dB/m)
2390.00	55.56	PK	74.00	18.44	1.00	283	60.87	27.49	3.32	36.12	-5.31
2390.00	43.95	AV	54.00	10.05	1.00	283	49.26	27.49	3.32	36.12	-5.31
Frequency(MHz):			2422			Polarity:			VERTICAL		
Frequency (MHz)	Emission Level (dBuV/m)		Limit (dBuV/m)	Margin (dB)	Antenna Height (m)	Table Angle (Degree)	Raw Value (dBuV)	Antenna Factor (dB/m)	Cable Factor (dB)	Pre-amplifier (dB)	Correction Factor (dB/m)
2390.00	54.51	PK	74.00	19.49	1.00	184	59.82	27.49	3.32	36.12	-5.31
2390.00	44.33	AV	54.00	9.67	1.00	184	49.64	27.49	3.32	36.12	-5.31
Frequency(MHz):			2452			Polarity:			HORIZONTAL		
Frequency (MHz)	Emission Level (dBuV/m)		Limit (dBuV/m)	Margin (dB)	Antenna Height (m)	Table Angle (Degree)	Raw Value (dBuV)	Antenna Factor (dB/m)	Cable Factor (dB)	Pre-amplifier (dB)	Correction Factor (dB/m)
2483.50	53.47	PK	74.00	20.53	1.00	278	59.19	27.45	3.38	36.55	-5.72
2483.50	42.27	AV	54.00	11.73	1.00	278	47.99	27.45	3.38	36.55	-5.72
Frequency(MHz):			2452			Polarity:			VERTICAL		
Frequency (MHz)	Emission Level (dBuV/m)		Limit (dBuV/m)	Margin (dB)	Antenna Height (m)	Table Angle (Degree)	Raw Value (dBuV)	Antenna Factor (dB/m)	Cable Factor (dB)	Pre-amplifier (dB)	Correction Factor (dB/m)
2483.50	54.78	PK	74.00	19.22	1.00	192	60.50	27.45	3.38	36.55	-5.72
2483.50	42.98	AV	54.00	11.02	1.00	192	48.70	27.45	3.38	36.55	-5.72



## 2.9. Spurious RF Conducted Emission

### Limit

1. Below -20dB of the highest emission level in operating band.
2. Fall in the restricted bands listed in section 15.205. The maximum permitted average field strength is listed in section 15.209.

### Test Procedure

The transmitter output was connected to the spectrum analyzer through a low loss RF cable. Spurious RF Conducted Emission was measured by spectrum analyzer with 100 KHz RBW and 300KHz VBW, measurement frequency range from 30MHz to 26.5GHz.

### Test Configuration

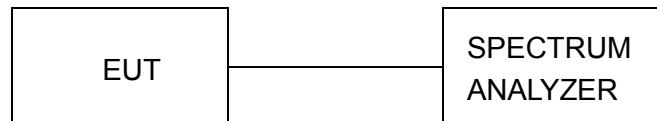

### Test Results

Remark: The measurement frequency range is from 30MHz to the 10th harmonic of the fundamental frequency. The lowest, middle and highest channels are tested to verify the spurious emissions and bandage measurement data.

Test plot as follows:



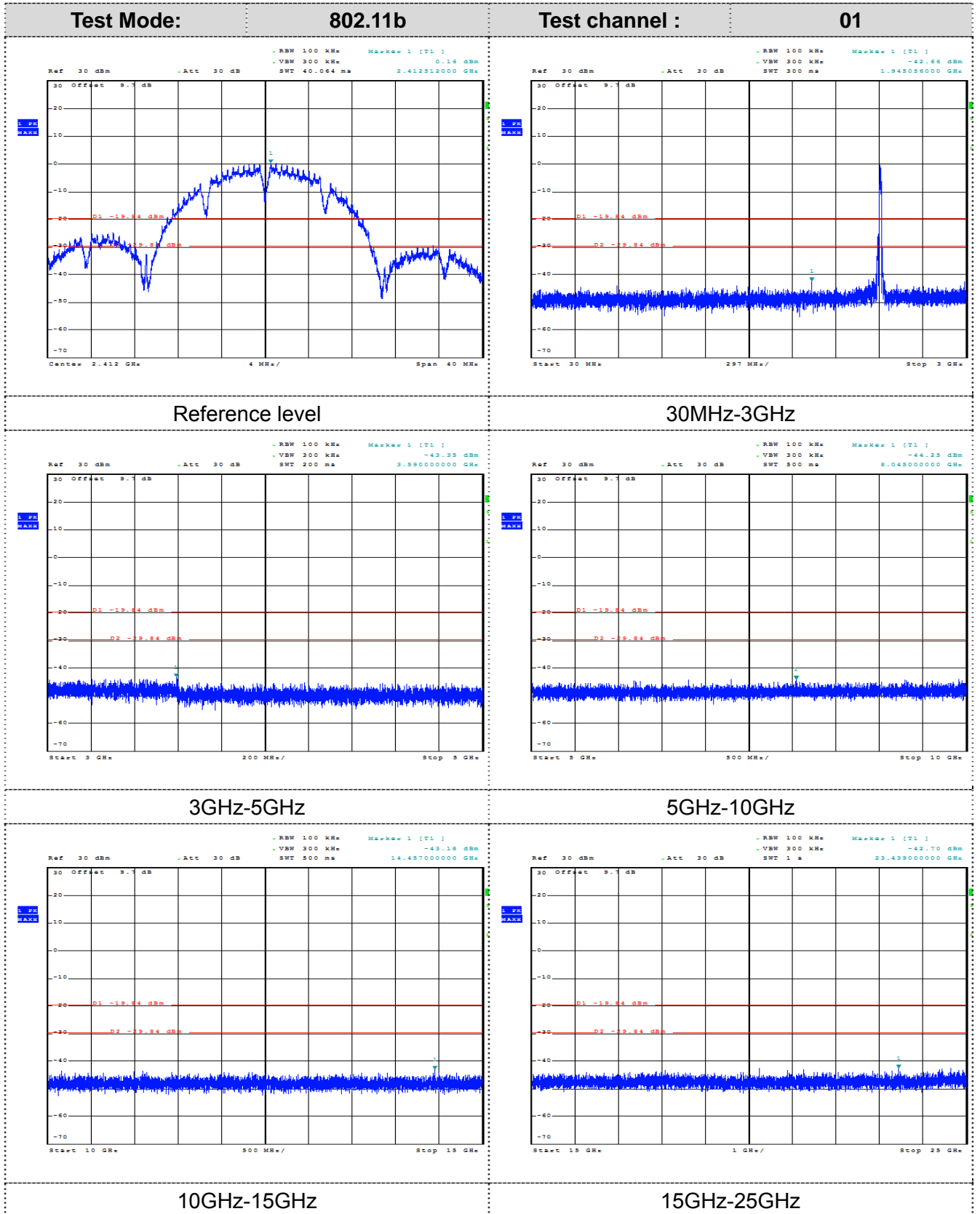

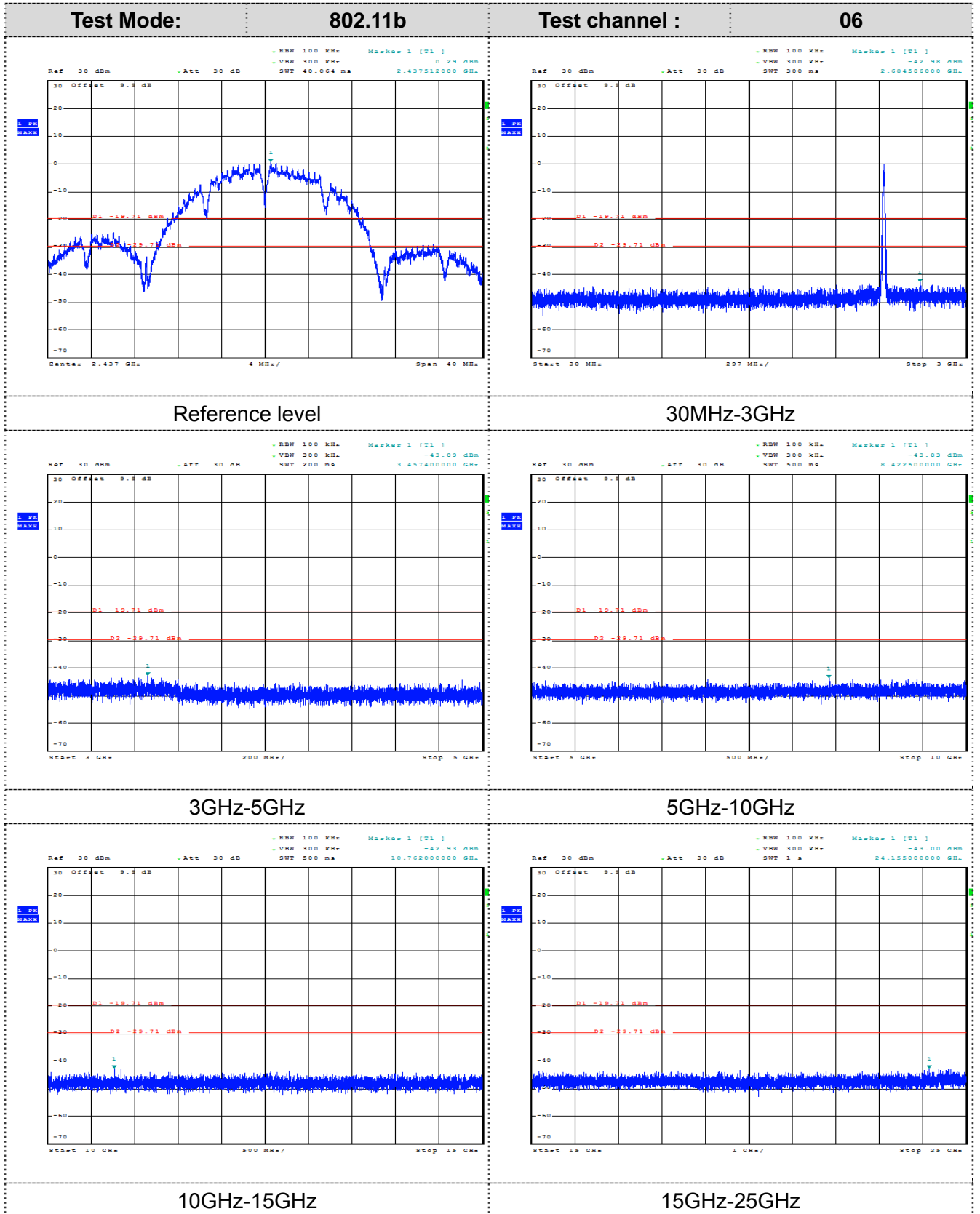

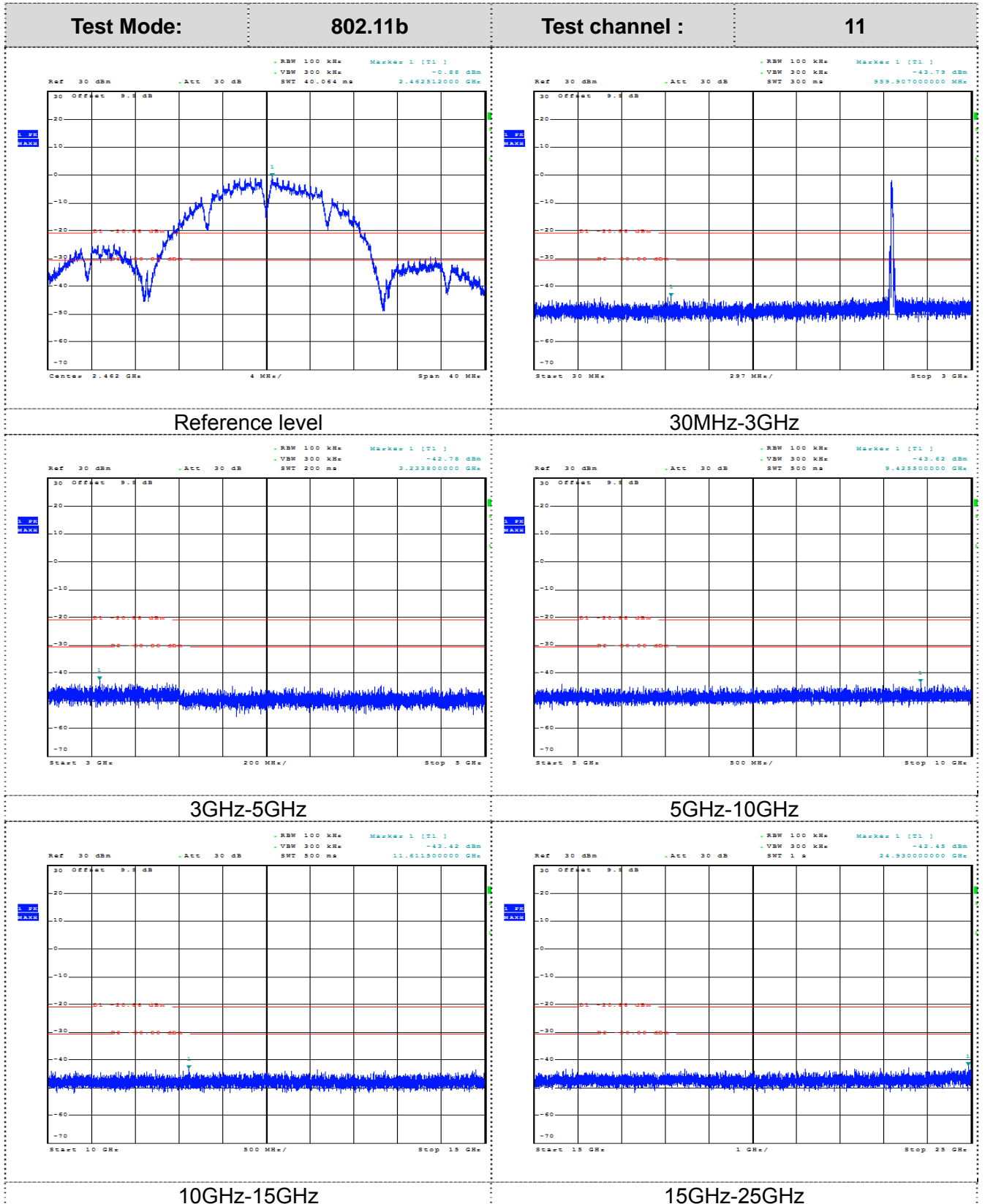

Test Mode:

802.11g

Test channel :

01

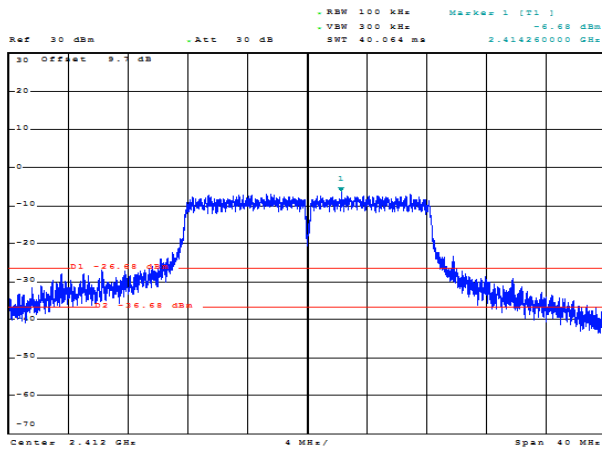

Reference level

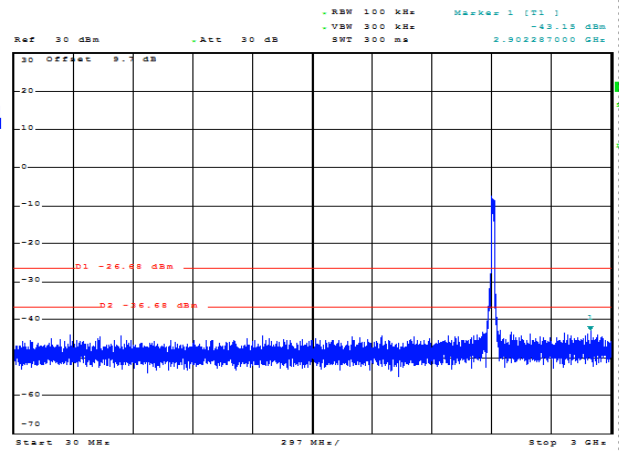

30MHz-3GHz

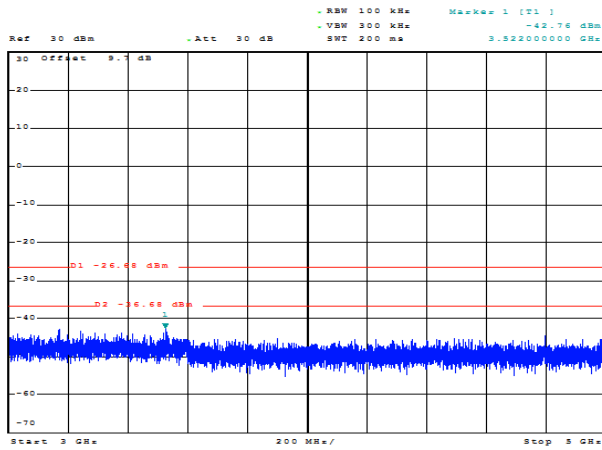

3GHz-5GHz

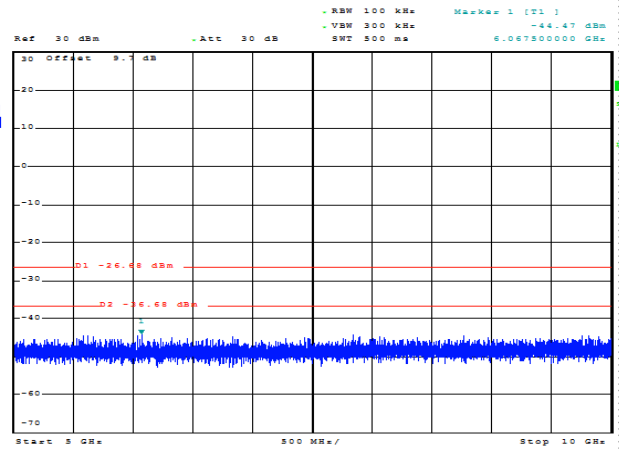

5GHz-10GHz

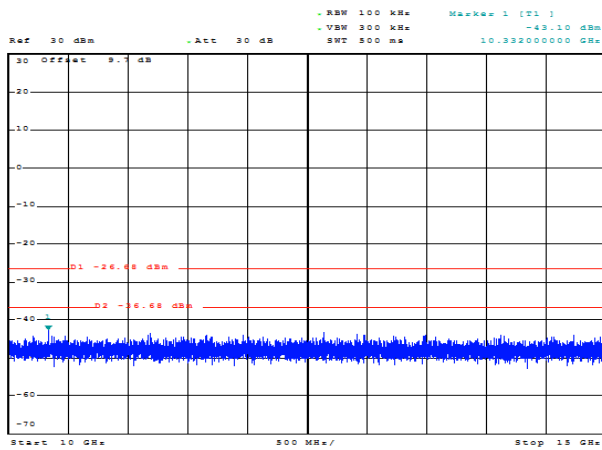

10GHz-15GHz

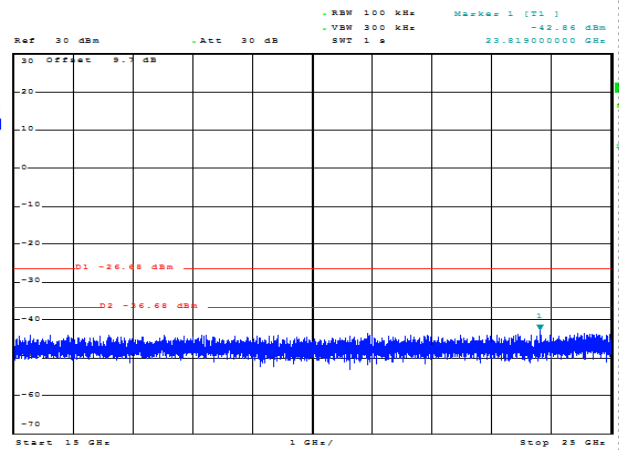

15GHz-25GHz

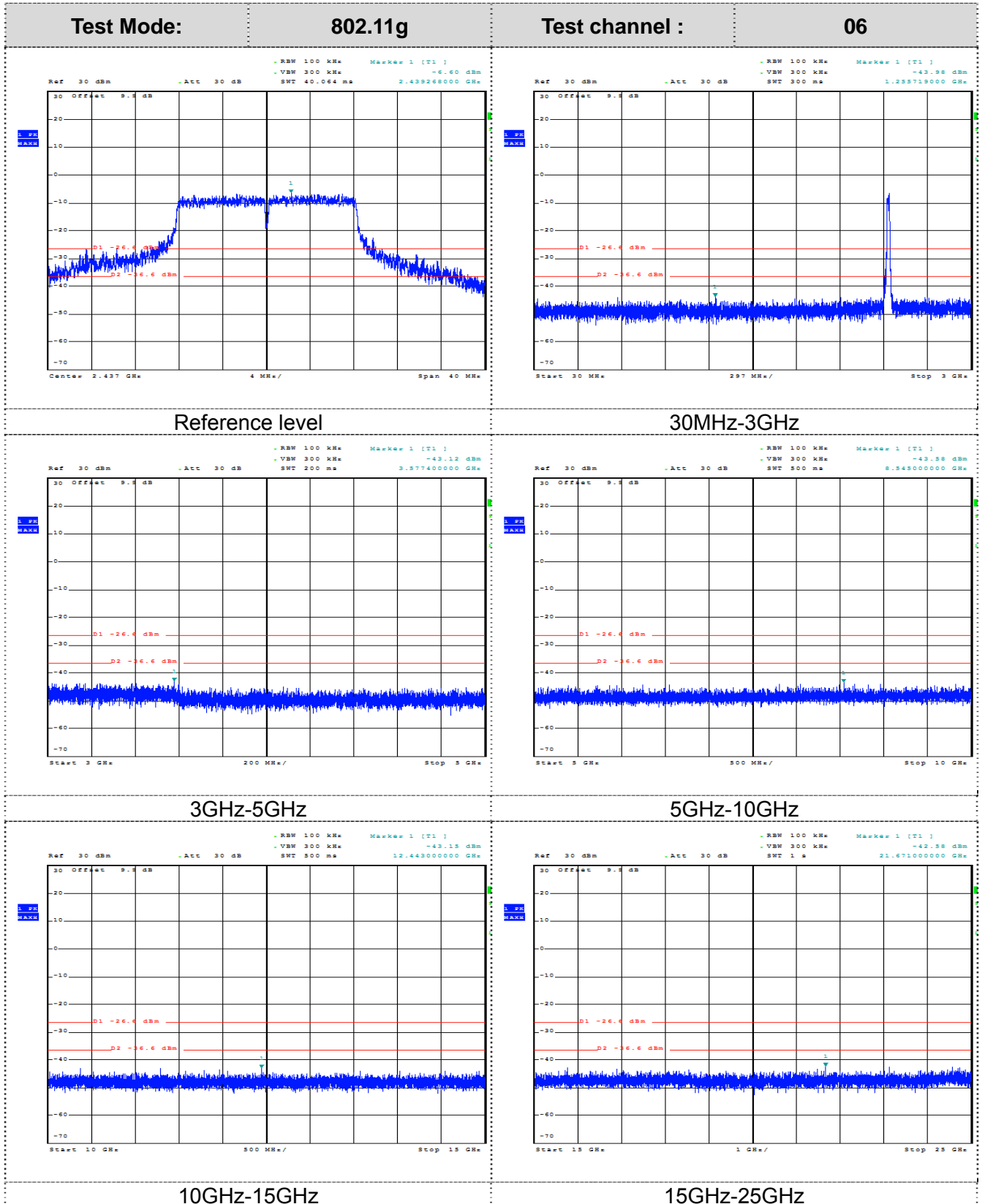

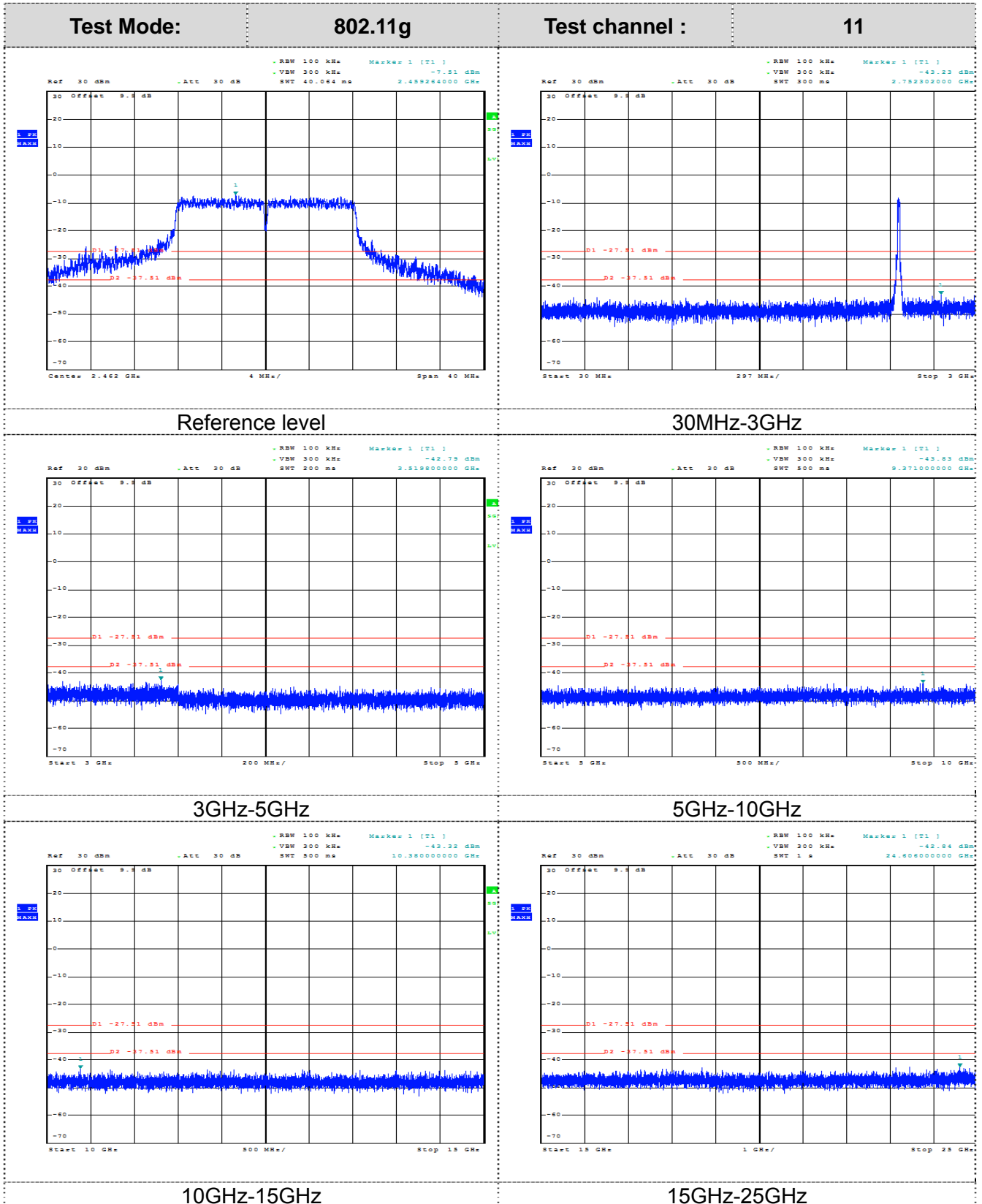

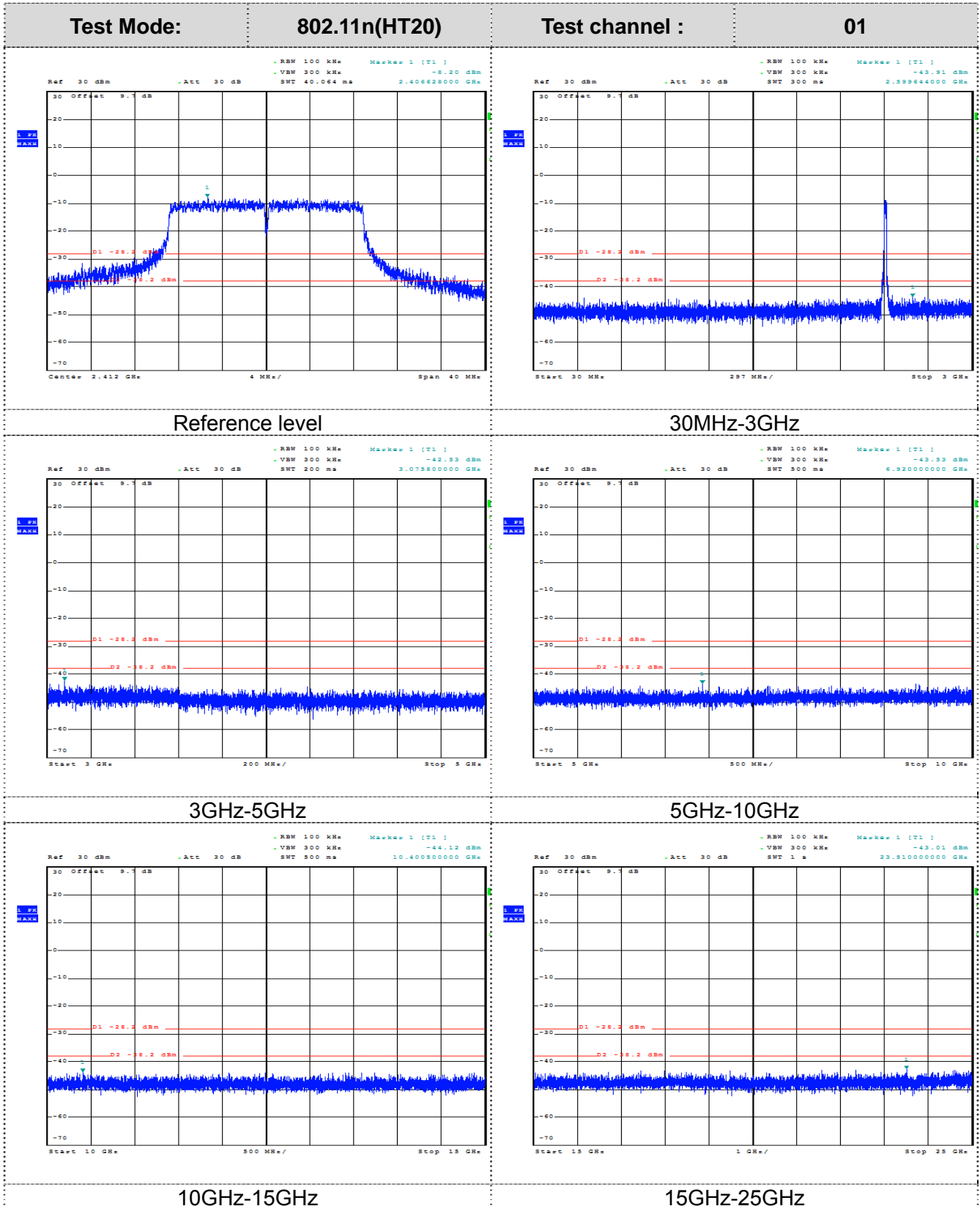

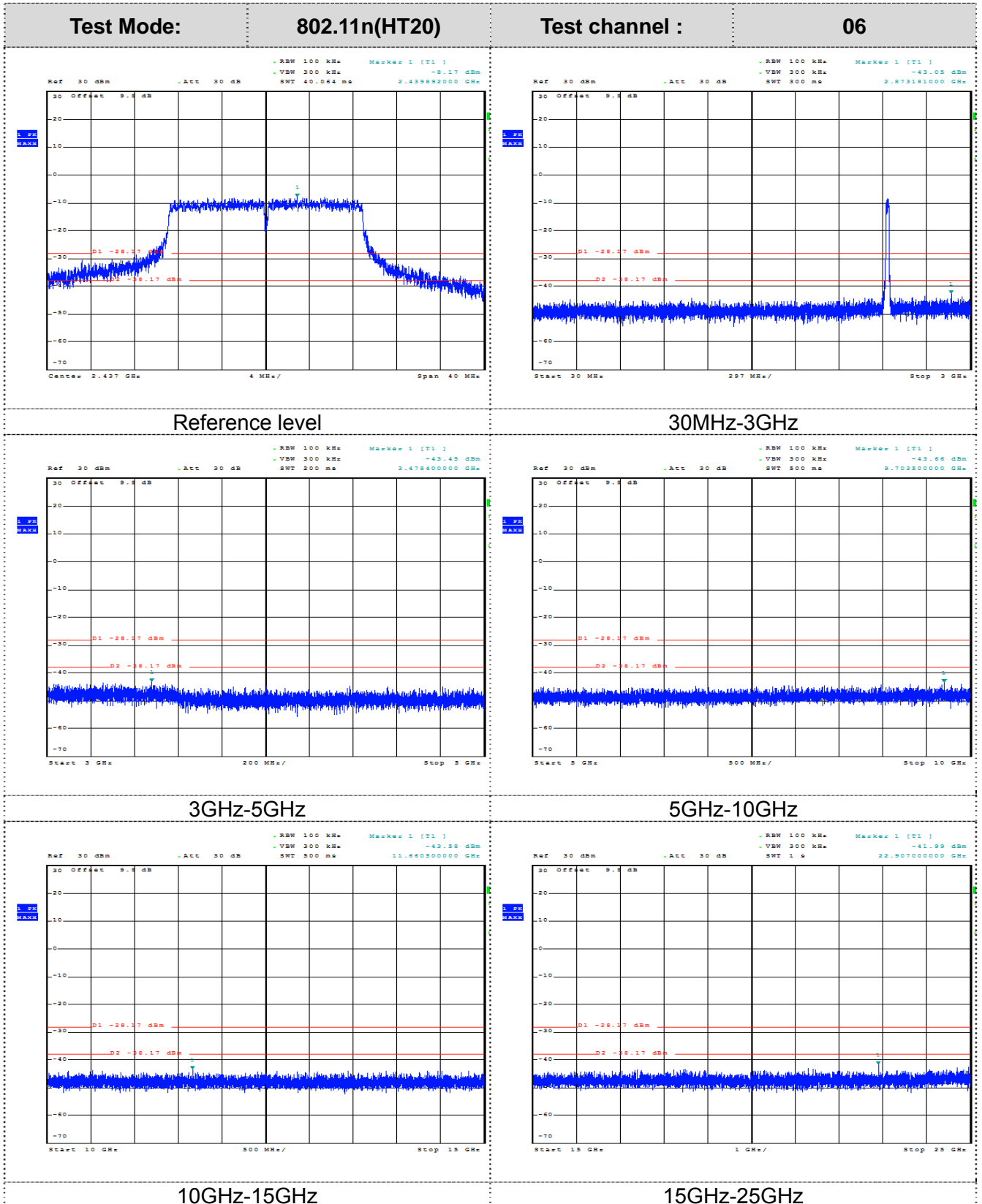



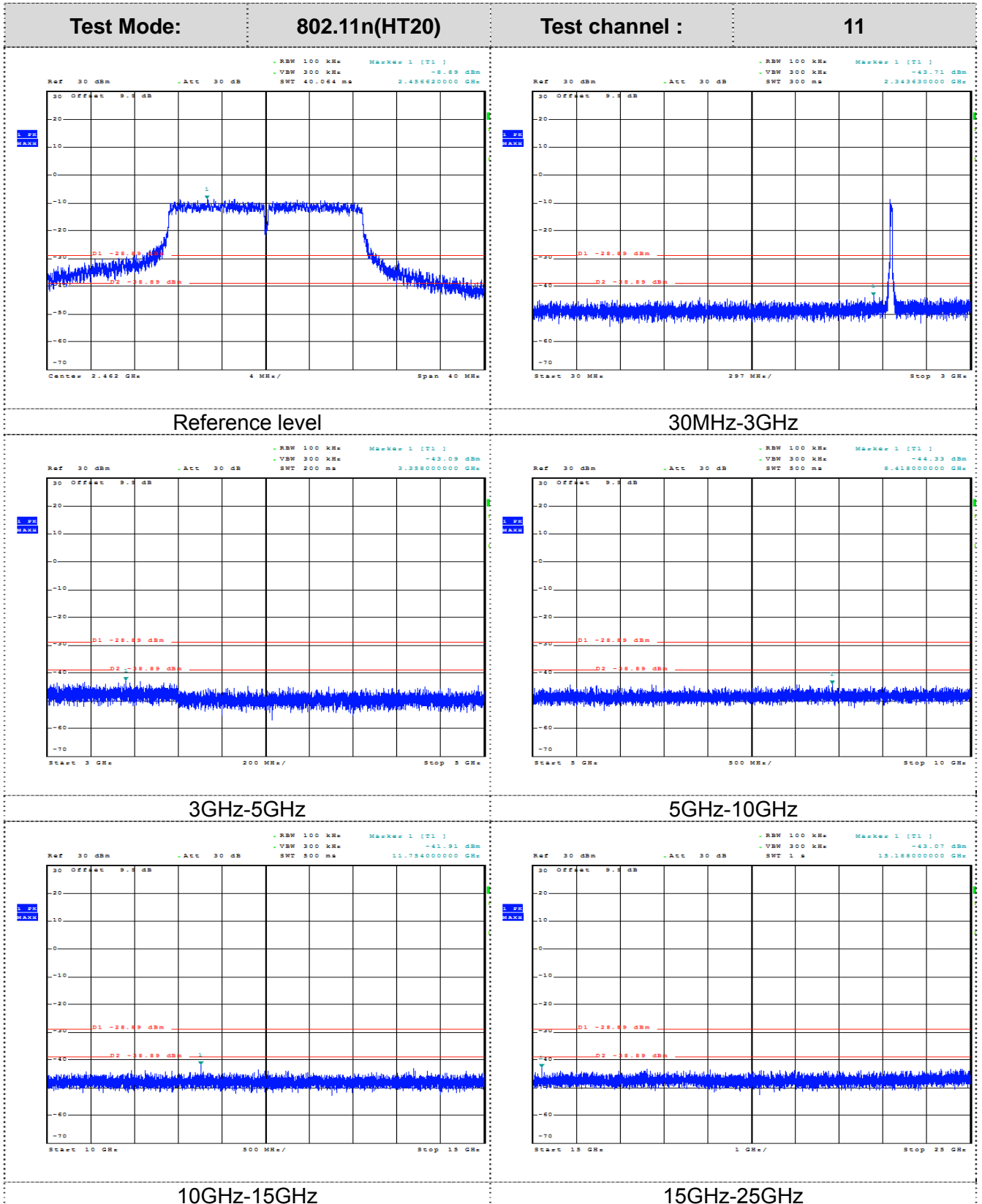

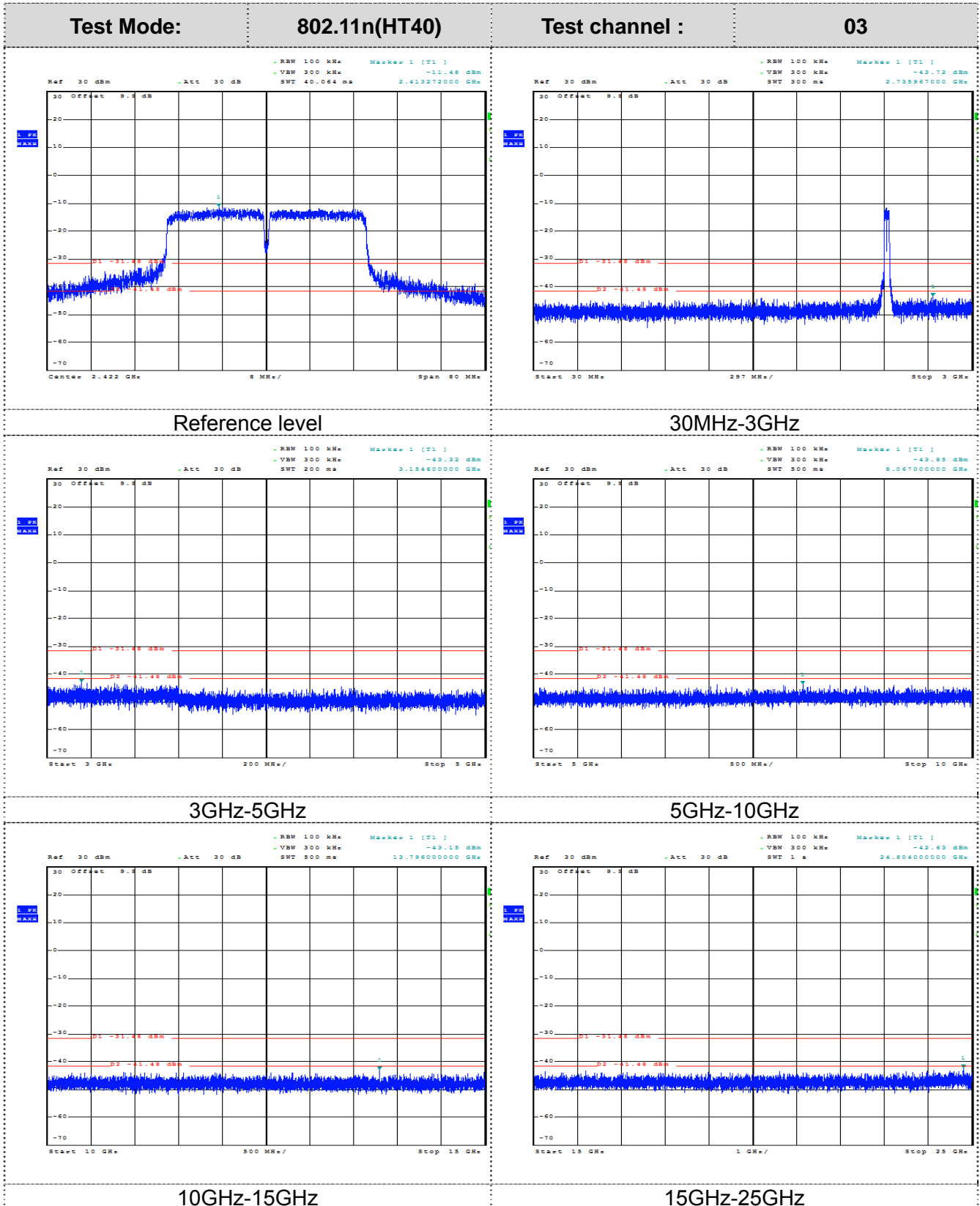

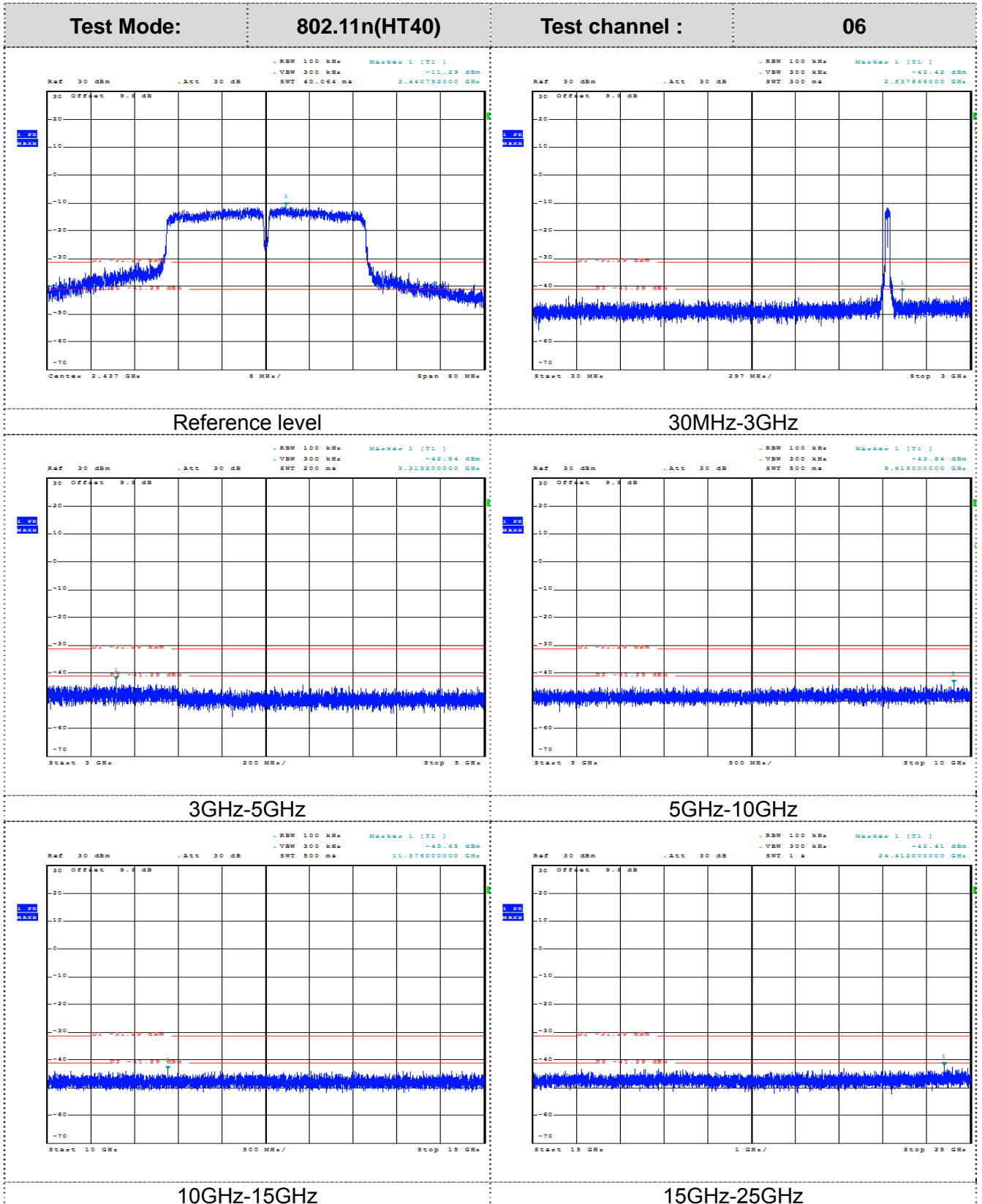

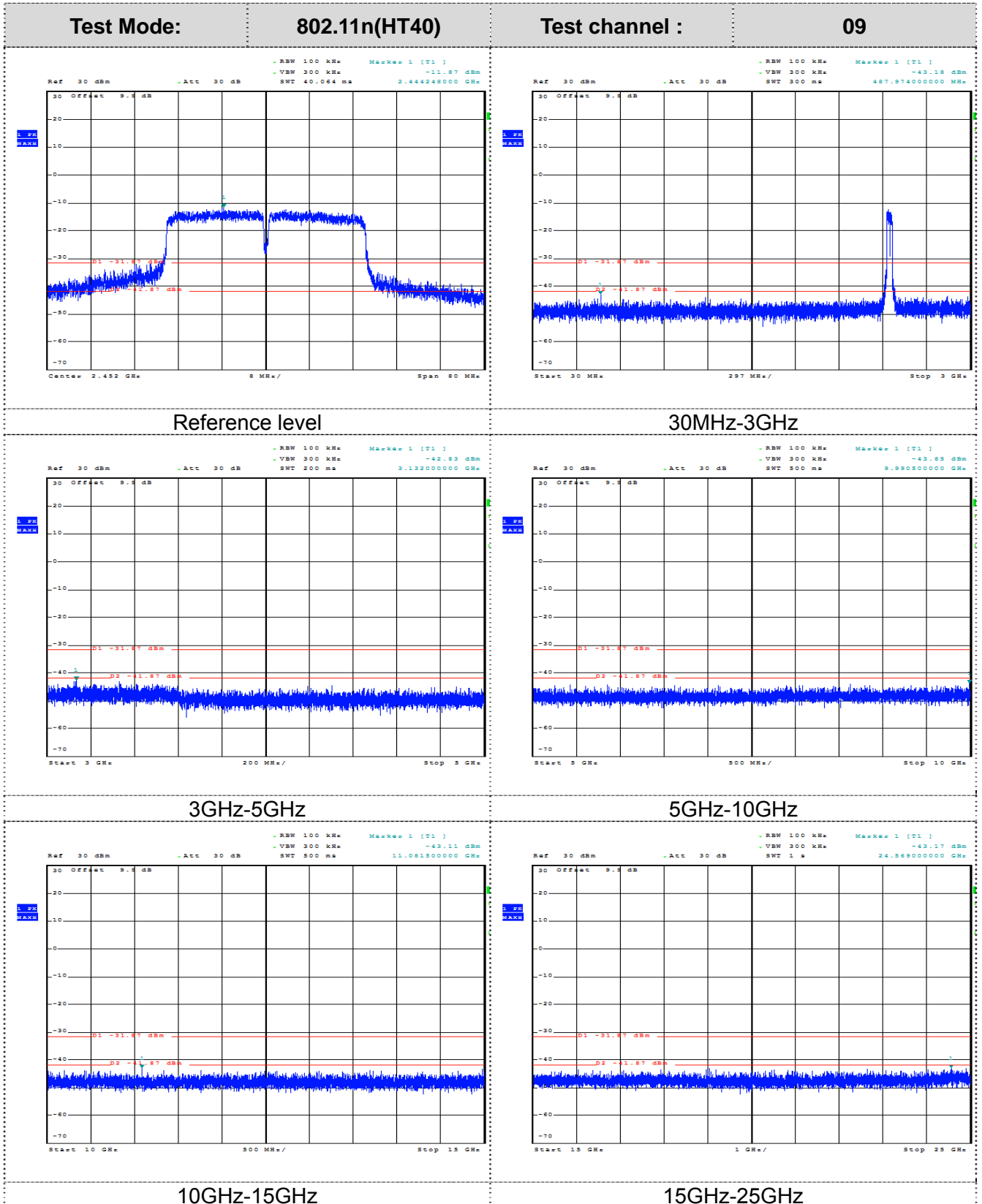

## 2.10. Antenna Requirement

### Standard Applicable

#### **For intentional device, according to FCC 47 CFR Section 15.203:**

An intentional radiator shall be designed to ensure that no antenna other than that furnished by the responsible party shall be used with the device. The use of a permanently attached antenna or of an antenna that uses a unique coupling to the intentional radiator, the manufacturer may design the unit so that a broken antenna can be replaced by the user, but the use of a standard antenna jack or electrical connector is prohibited

#### **FCC CFR Title 47 Part 15 Subpart C Section 15.247(c) (1) (I):**

(i) Systems operating in the 2400-2483.5 MHz band that is used exclusively for fixed. Point-to-point operations may employ transmitting antennas with directional gain greater than 6dBi provided the maximum conducted output power of the intentional radiator is reduced by 1 dB for every 3 dB that the directional gain of the antenna exceeds 6dBi.

#### **Test Result:**

The maximum gain of WIFI antenna was 3.0dBi.

Antenna Style: Monopole Antenna, Antenna port: SMA





### 3. EUT TEST PHOTO

Radiated Emission (30MHz-1GHz)



Radiated Emission (1GHz-25GHz)



Conducted Emission

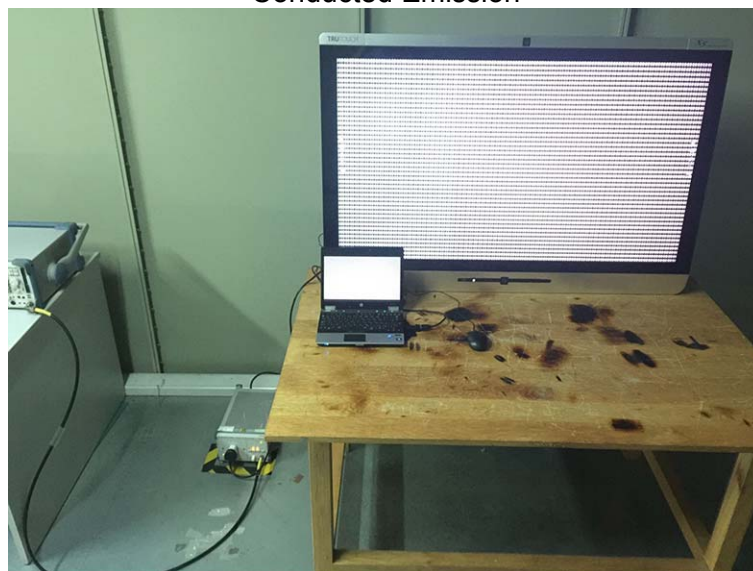

## 4. PHOTOGRAPHS OF EUT CONSTRUCTIONAL

External Photos of EUT











### Internal Photos of EUT

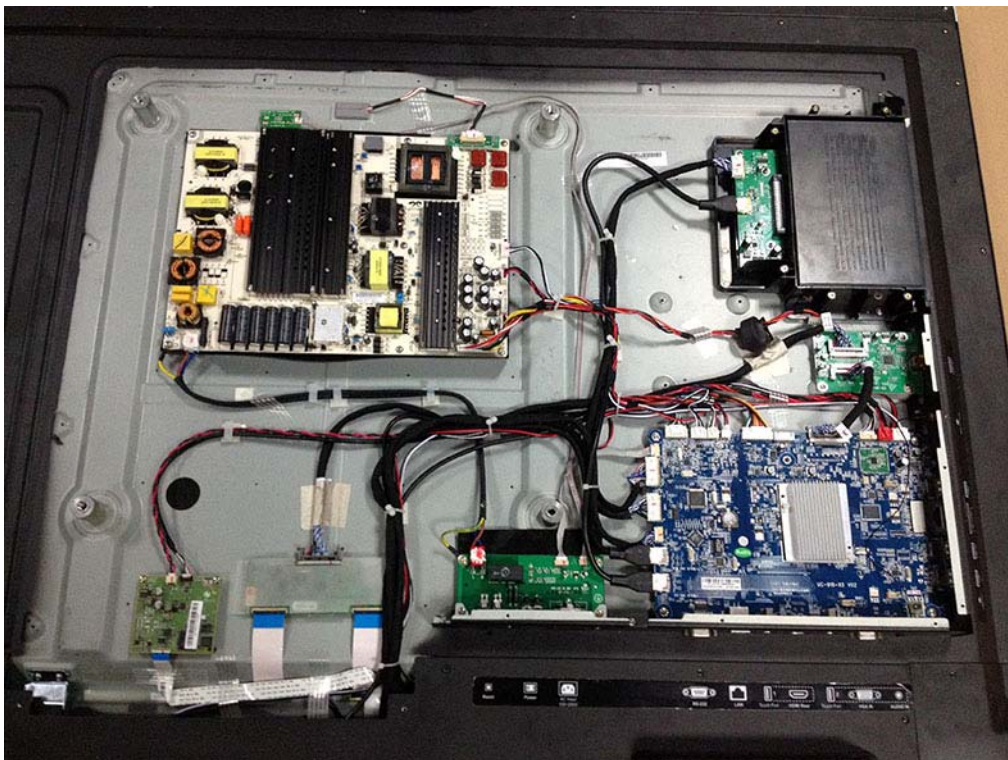



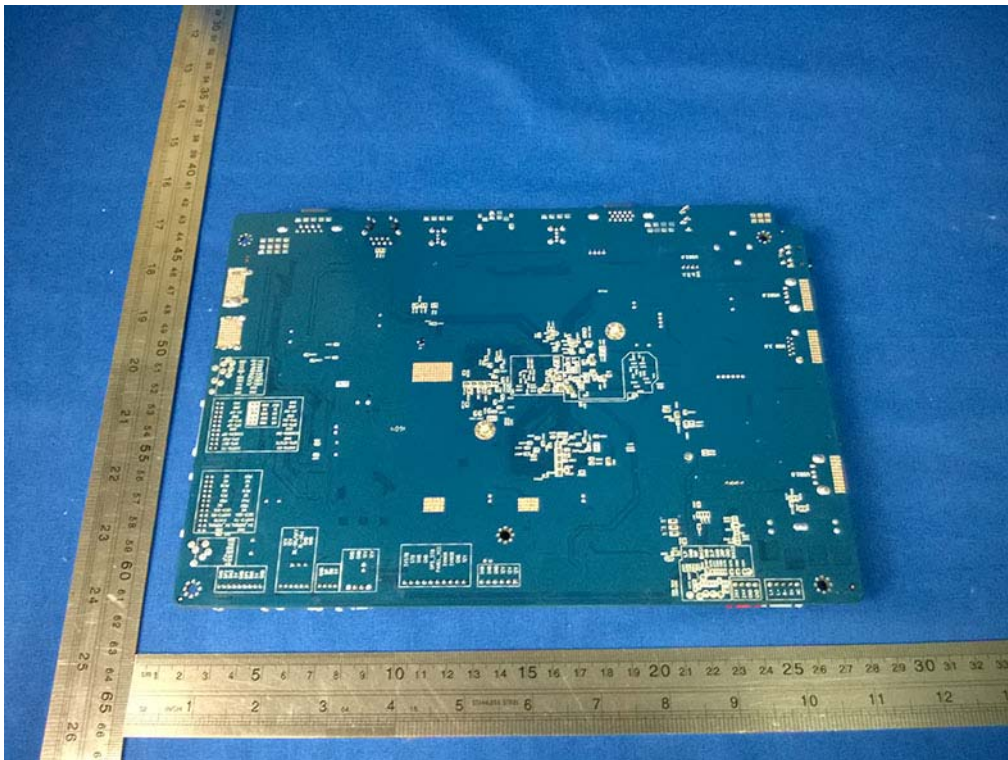
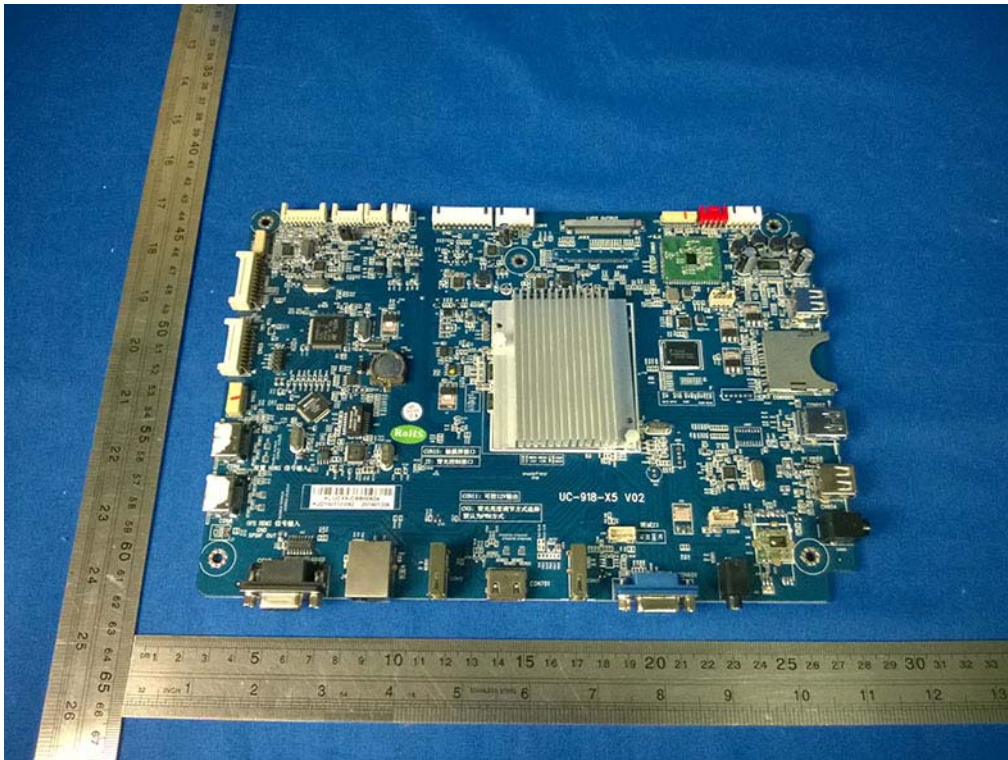



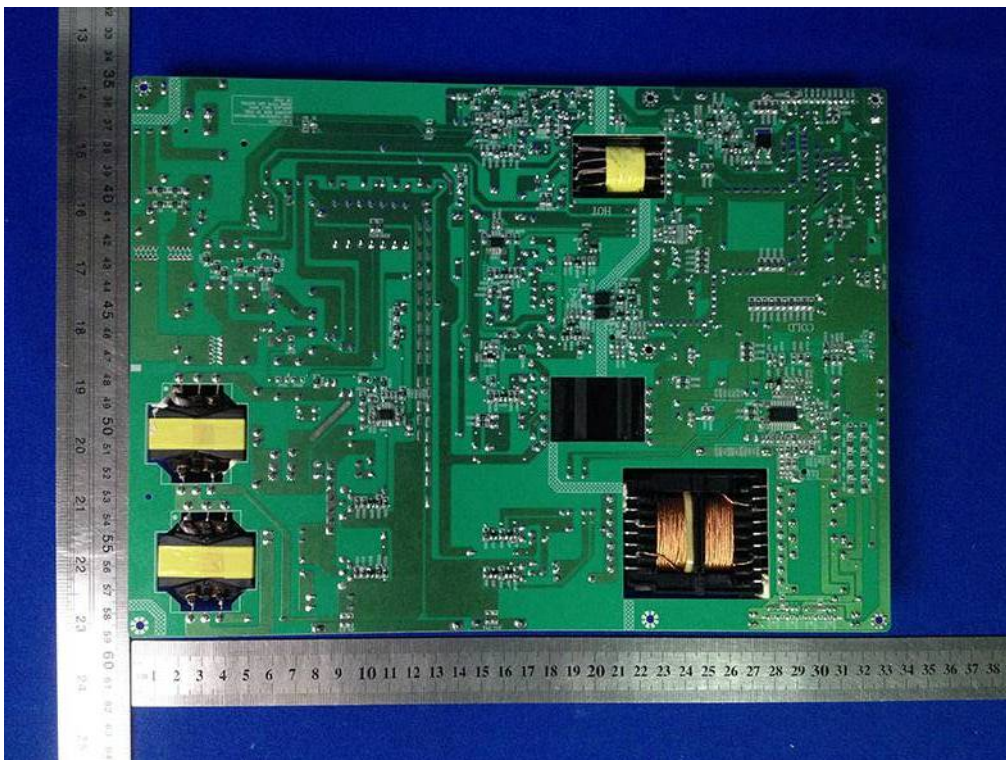
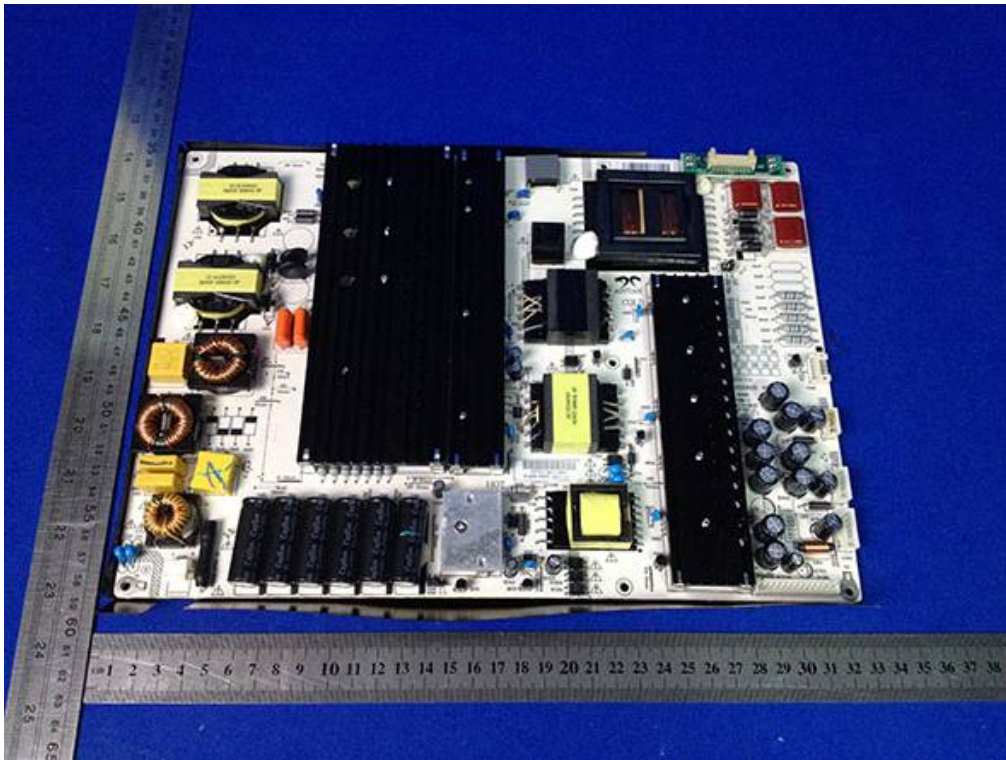



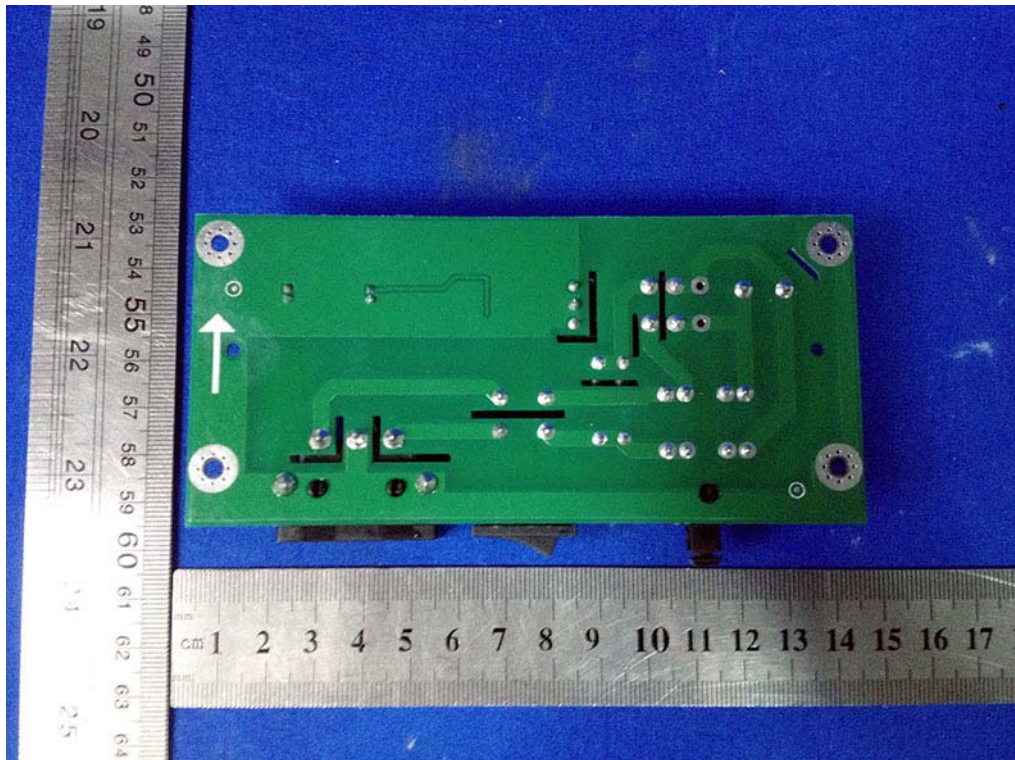
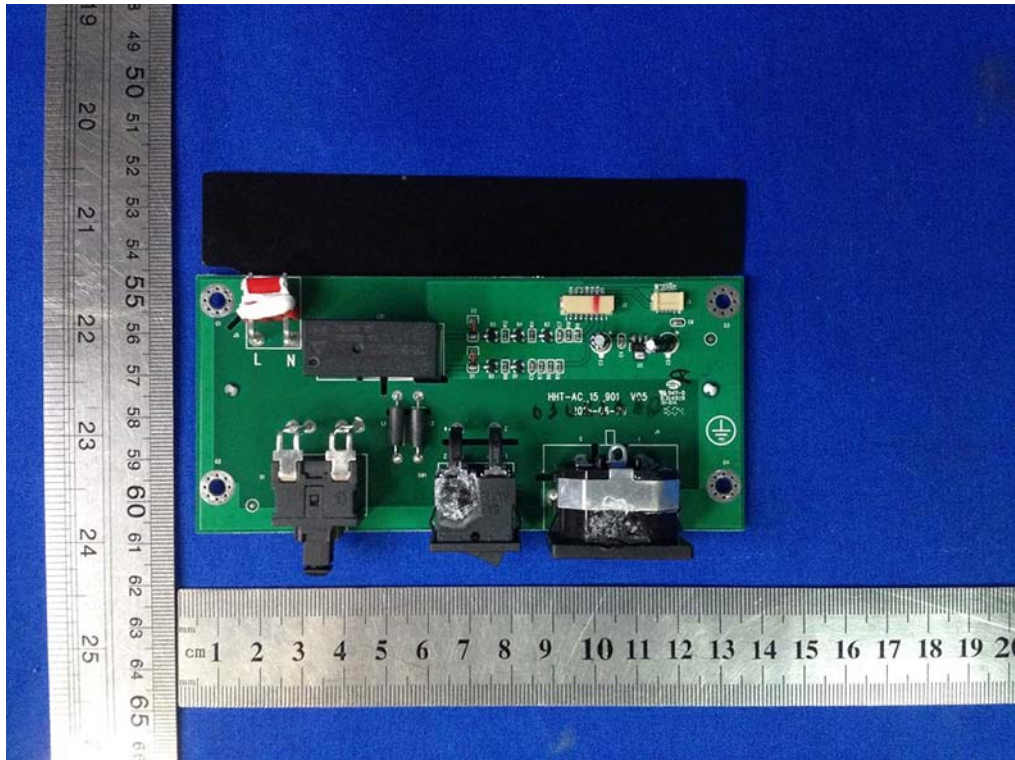

\*\*\*\*\*THE END\*\*\*\*\*