

深圳市鑫尔盛科技有限公司

【物料承认书】

APPROVAL SHEET

客户 (Customer) : 东莞市悦顺电子科技有限公司

产品名称 (Description) : 天线

产品规格 (spec) : 2.4G/5.8G 5DB 出双线, 1.13 黑色线 L=30MM, 1.13 黑色线 L=105MM

客户料号 (Cus P/N) : 118C-13041007901

料号 (Part NO) : SFANT11A15456

日期 (Date) : 2022-10-22

版本 (Version) : _____

| | | |
|-------------------|------------------|----------------|
| 核准 APPROVED BY | 审核 CHECKED BY | 制作 DRAWN BY |
| 李庆辉 | 方立志 | Ande |

Please sign back after confirmation:

Client signature: Qualified Unqualified

| | | |
|----------------|---------------|---------------|
| 批准 APPROVAL | 审核 CHECKED | 检验 CONFORM |
| | | |

地址(Adress): 深圳市宝安区福永镇凤凰社区岭下路 96 号 D 栋 3 楼

电话(TEL): 0755-33881455

传真(FAX): 0755-33233276

Email: liqinghui@xinershengant.com



深圳市鑫尔盛科技有限公司

ShenZhen XinErSheng Technology Co.,Ltd

产品主要技术参数

| 主要技术参数 | | Main technical specifications | |
|---------------------------|---------------------------------------------|-------------------------------|---------------------------------------------|
| 频率范围 (MHZ) | 2400-2483/5150-5825 | Frequency Range(MHZ) | 2400-2483/5150-5825 |
| 中心频率 特性阻抗 (Ω) | 50 ± 10 | Impedance(Ω) | 50 ± 10 |
| 增益 (dBi) | 4.0 ± 1 | Gain(dBi) | 4.0 ± 1 |
| 反射损耗 | ≤ -10 | ReTurnLoss(dB) | ≤ -10 |
| 输出电压驻波比 | ≤ 1.92 | VSWR | ≤ 1.92 |
| 最大功率 | 1W | Admitted Power | 1W |
| 极化方式 | 垂直极化 | Polarization | Linear Vertical |
| 连接方式 | IPEX | Connector Type | IPEX |
| 物理特性 | | Physical Properties | |
| 天线本体材料 | TPE | Antenna Base | TPE |
| 工作温度 | $-20^{\circ}\text{C} - +60^{\circ}\text{C}$ | Operating Temp | $-20^{\circ}\text{C} - +60^{\circ}\text{C}$ |
| 保存温度 | $-20^{\circ}\text{C} - +70^{\circ}\text{C}$ | Storage Temp | $-20^{\circ}\text{C} - +70^{\circ}\text{C}$ |

产品图纸

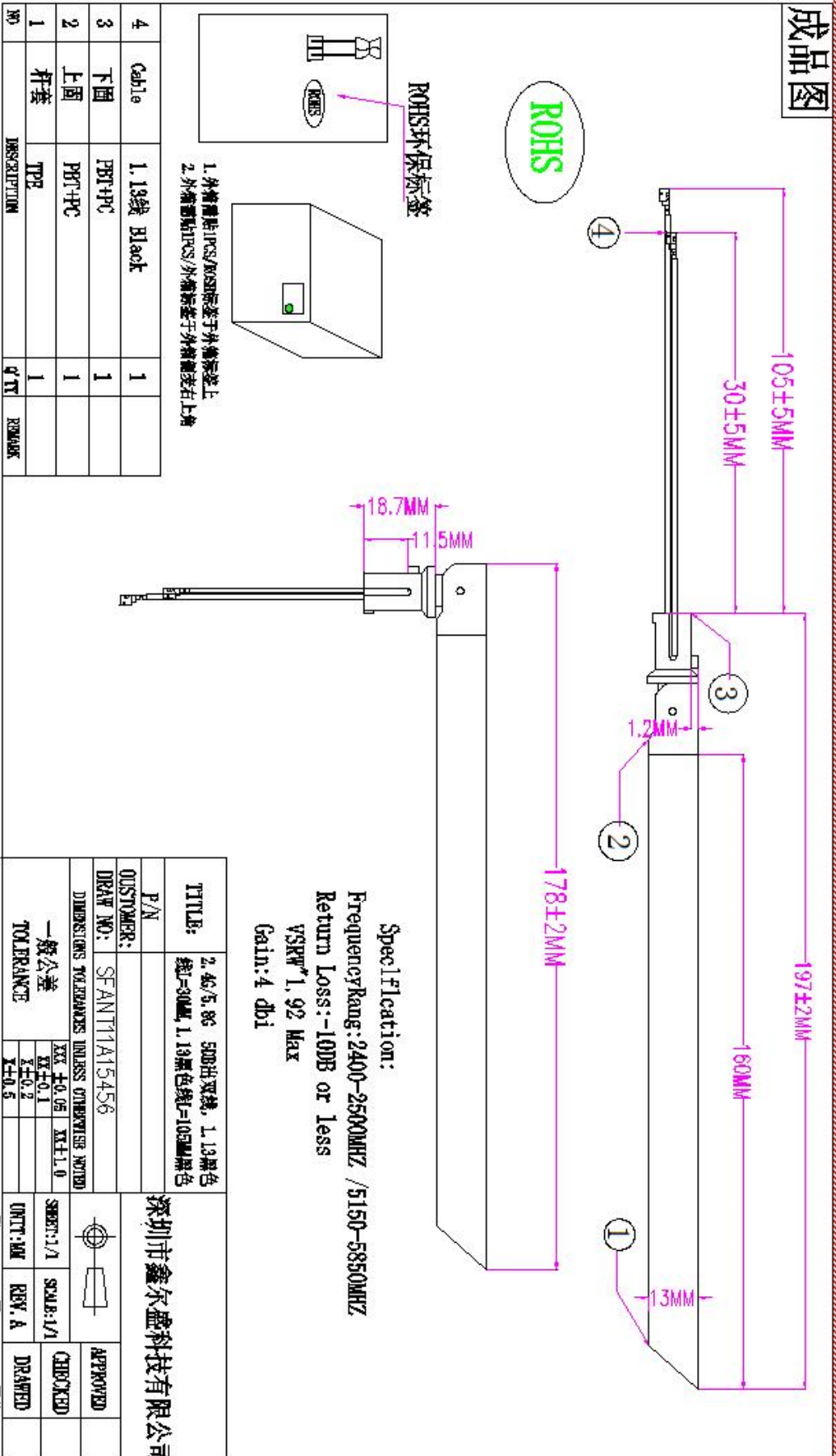

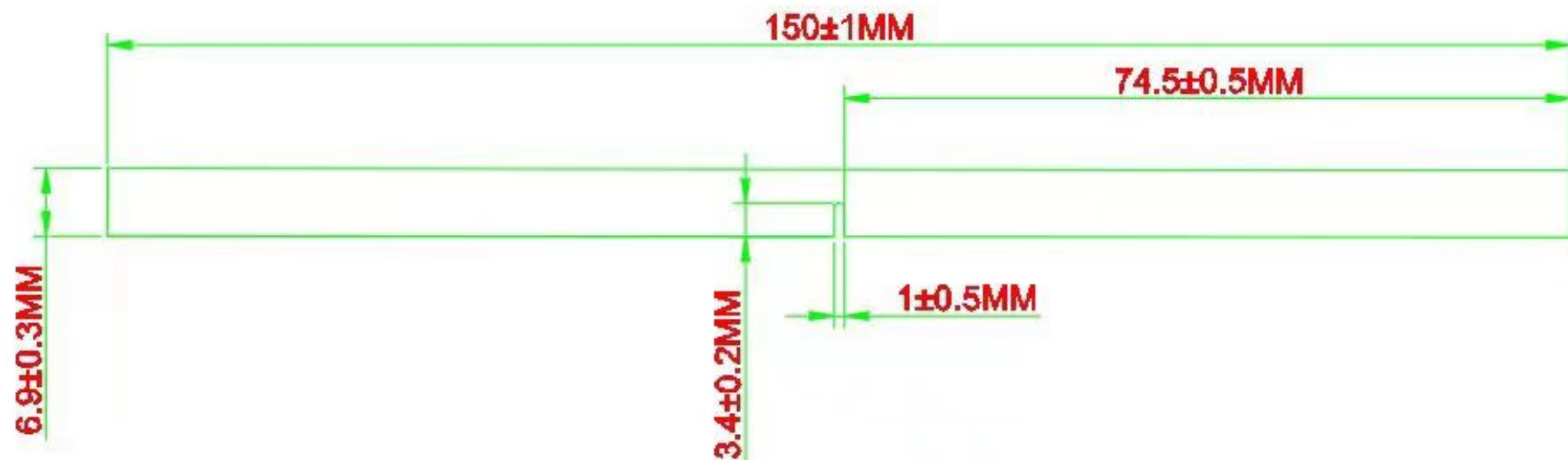

技术要求:

1. 所有单位尺寸为mm。
2. 材料: FR4, 板厚0.8, 介电常数4.4
3. 工艺: 焊盘做OSP工艺, 表面单面绿色油墨
4. 所有尺寸为管控尺寸,

| | | | | | | | | |
|--------------|-----------|-----------|--------|------------|----|--------|---------------------|----------------|
| 深圳市鑫尔盛科技有限公司 | | | | | | | 名称: XES220902 | |
| 单位 mm | 比例 1:1 | 材料 FR4 | 一般加工 | 表面处理 喷油 | | | | |
| 数量 1 | 颜色 绿色 | 设计 | 射频 | 审核 | | | | |
| | | Y M | Y M | Y M | 批准 | Y M | Y M | Y M |
| | | | | | | | 绘制时间: 2023.03.04 | 第 1 页 共 1 页 |

Feeder length $L=105\text{MM}$

Test report:

SWR



Log Mag

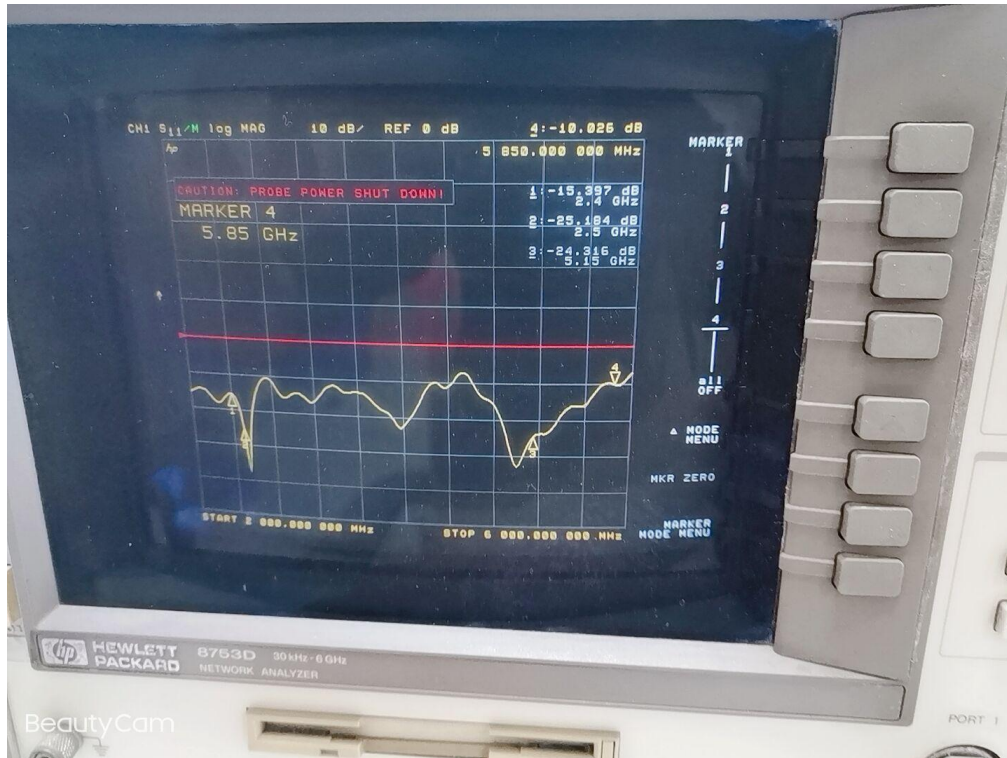

Feeder length $L=30\text{MM}$

Test report:

SWR

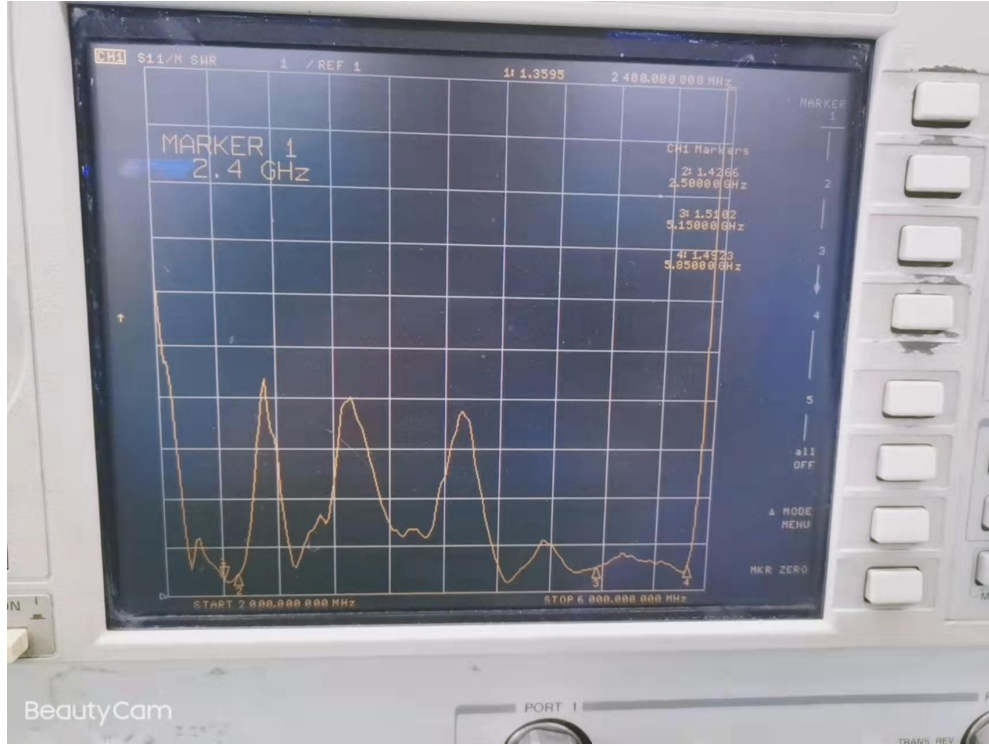

Log Mag

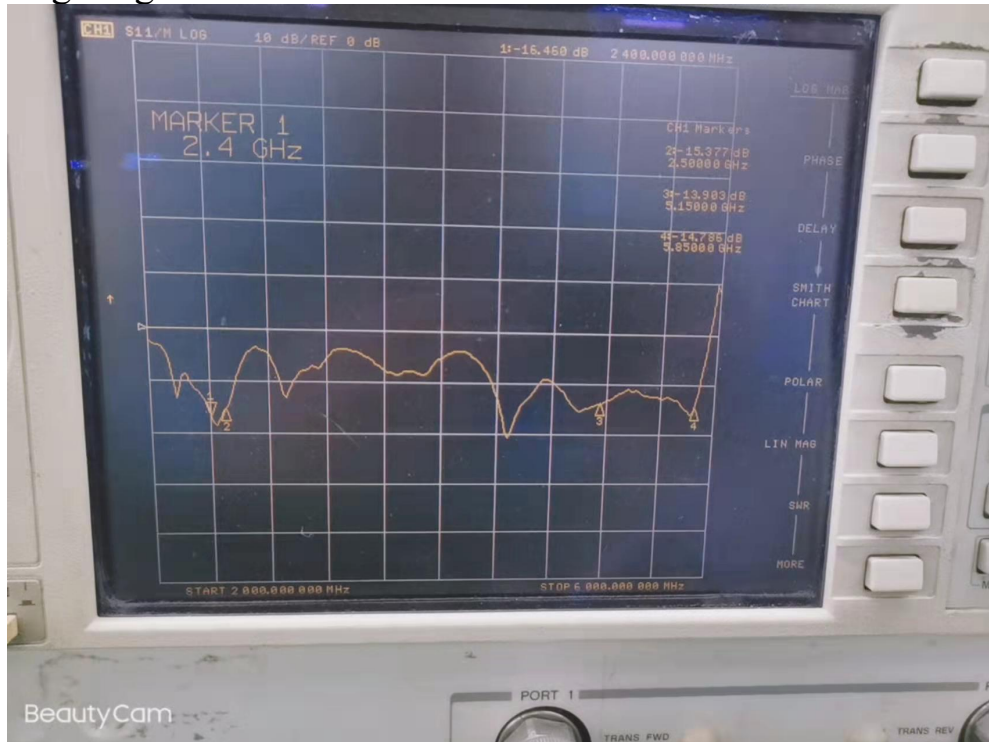



深圳市鑫尔盛科技有限公司

ShenZhen XinErSheng Technology Co.,Ltd

Feeder length L=105MM

2D、3DRaditation Pattern

| | | |
|--------------|---------------------------|-------------------------|
| | | |
| <p>2.4G</p> | <p>Gain(Peak):3.33dBi</p> | <p>Efficiency:61.5%</p> |
| | | |
| <p>2.45G</p> | <p>Gain(Peak):2.91dBi</p> | <p>Efficiency60.8%</p> |
| | | |
| <p>2.5G</p> | <p>Gain(Peak):3.56dBi</p> | <p>Efficiency:63.4%</p> |

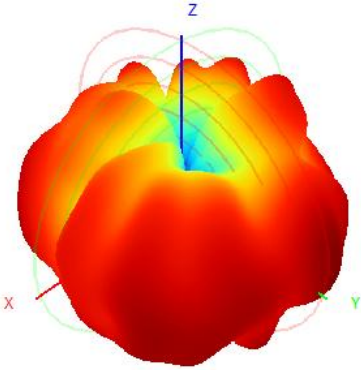
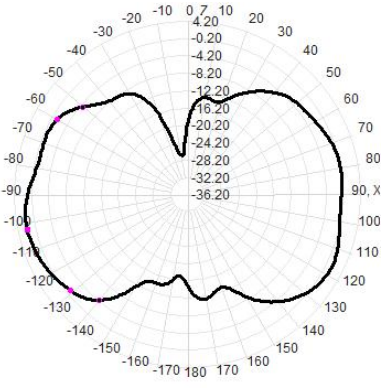
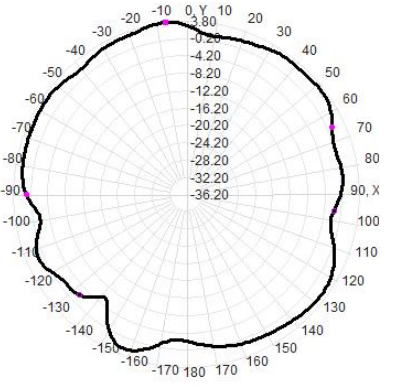
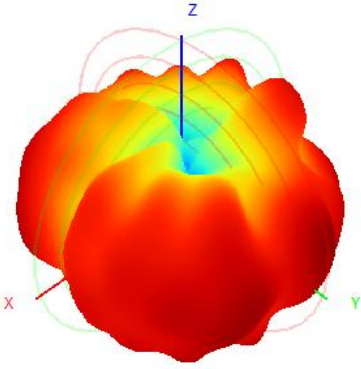
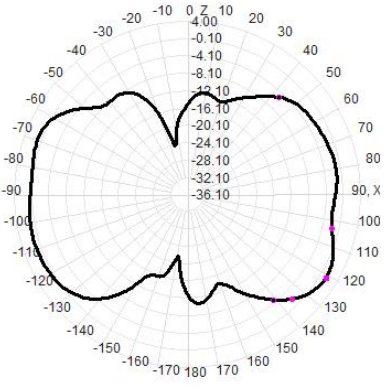
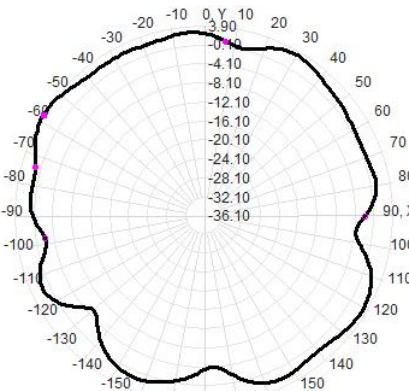
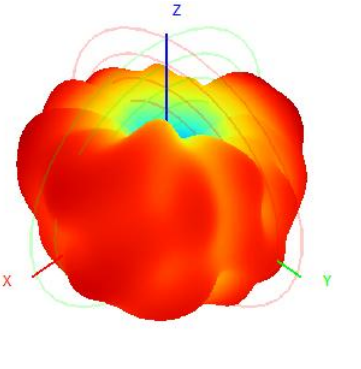
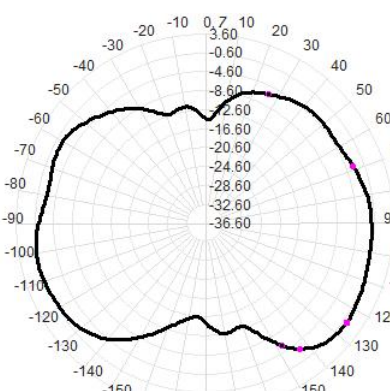
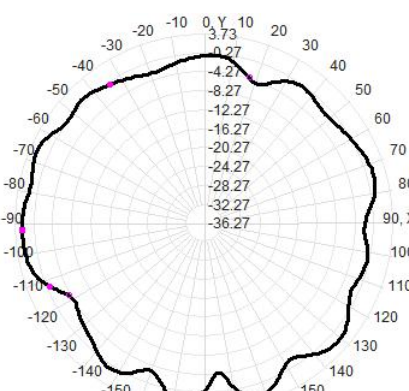
| | | |
|-------------------------------------------------------------------------------------|--------------------------------------------------------------------------------------|---------------------------------------------------------------------------------------|
|  |  |  |
| <p>5.15G</p> | <p>Gain(Peak):3.8dBi</p> | <p>Efficiency:64.1%</p> |
|  |  |  |
| <p>5.5G</p> | <p>Gain(Peak):3.9dBi</p> | <p>Efficiency65.2%</p> |
|  |  |  |
| <p>5.85G</p> | <p>Gain(Peak):3.4dBi</p> | <p>Efficiency:64.3%</p> |

Feeder length L=30MM

2D、3DRaditation Pattern

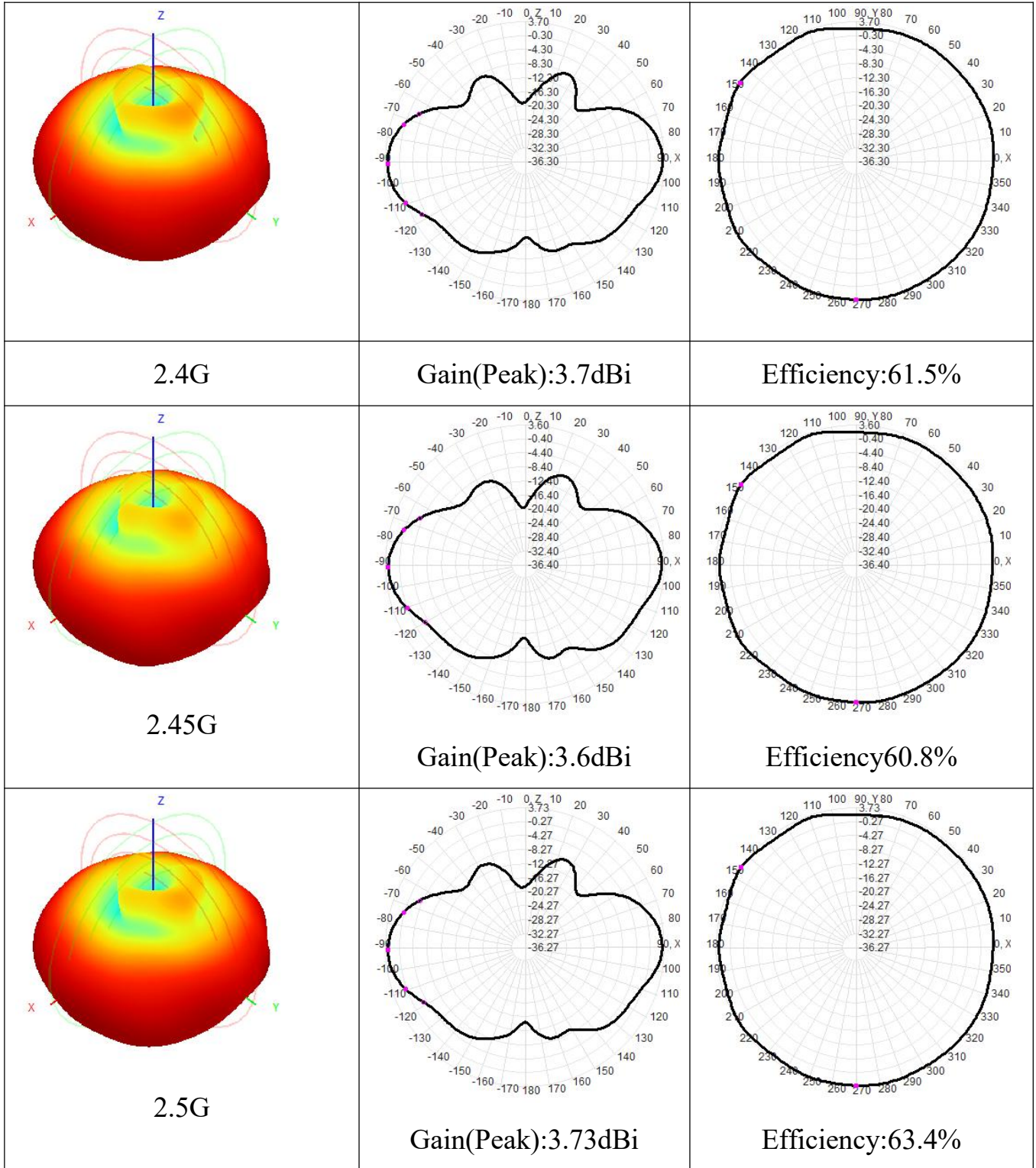

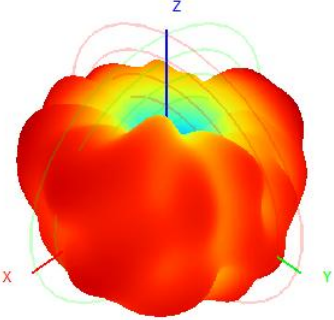
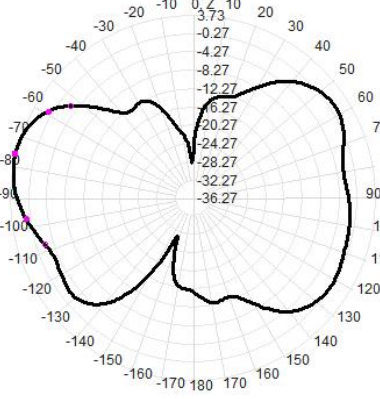
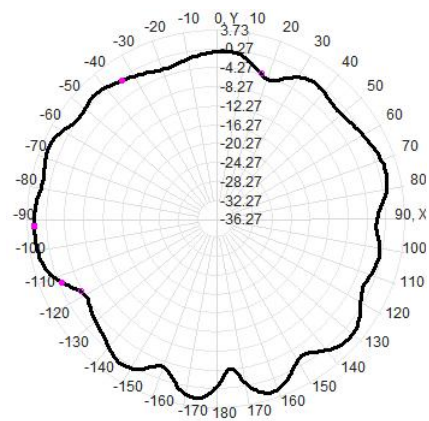
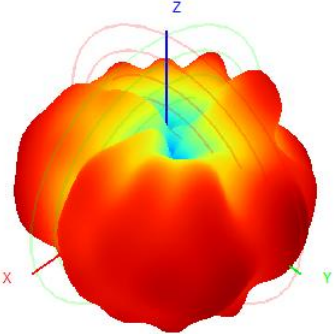
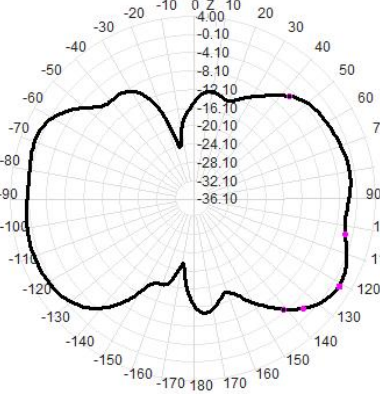
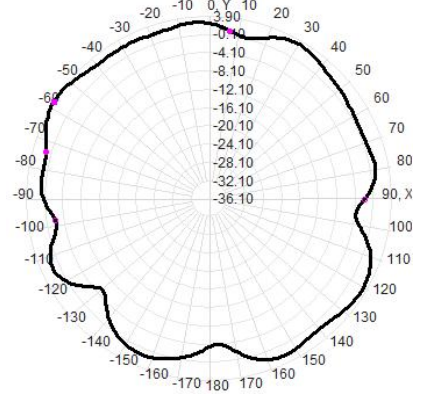
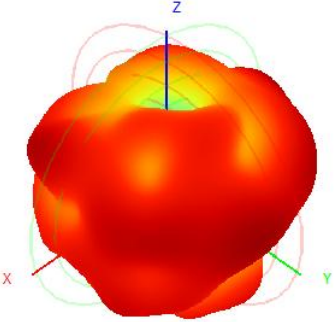
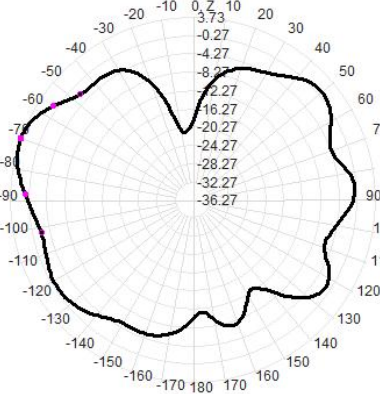
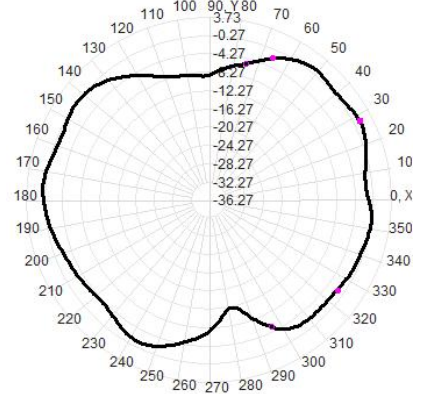
| | | |
|--------------------------------------------------------------------------------------------------|----------------------------------------------------------------------------------------------------------------|---------------------------------------------------------------------------------------------------------------|
|  |  |  |
| <p>5.15G</p> | <p>Gain(Peak):3.73dBi</p> | <p>Efficiency:64.1%</p> |
|  <p>5.5G</p> |  <p>Gain(Peak):3.9dBi</p> |  <p>Efficiency:65.2%</p> |
|  <p>5.85G</p> |  <p>Gain(Peak):3.73dBi</p> |  <p>Efficiency:64.3%</p> |