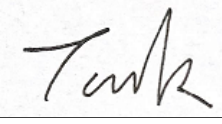
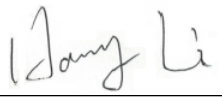

## Test report

**Report No.:** 2ACYT-AZ720  
**FCC ID:** wireless module  
**Product Name** AZ720  
**Test Model:** N/A  
**Received Date:** 2019-11-12  
**Test Date:** 2019-11-15~2019-12-12  
**Issued Date:** 2019-12-17  
**Applicant Name:** SHENZHEN Hitevision Technology Co., Ltd.  
**Applicant Address:** No. 8, Qinglan 1st Road, Pingshan Shenzhen China  
**Issued By:** Hwa-Hsing (Dongguan) Testing Co., Ltd.  
**Lab Address:** No.101, Bld N1,Yuyuan 2Rd, Yuyuan Industrial Park, HuangJiang Town, Dongguan, China  
**Test Location:** No.101, Bld N1,Yuyuan 2Rd, Yuyuan Industrial Park, HuangJiang Town, Dongguan, China  
**FCC Designation Number:** CN1255  
**Standards:** FCC Part 15, Subpart E, Section 15.407

The above equipment has been tested by [HWA-HSING](#), and found compliance with the requirement of the above standards. The test record, data evaluation & Equipment Under Test (EUT) configurations represented herein are true and accurate accounts of the measurements of the sample's EMC characteristics under the conditions specified in this report.

**Prepared by :**  , **Date:** Dec. 17, 2019  
Tank Tan//Engineer

**Approved by :**  , **Date:** Dec. 17, 2019  
Harry Li/ Supervisor

For Lab's declaration: This report is for your exclusive use. Any copying or replication of this report to or for any other person or entity, or use of our name or trademark, is permitted only with our prior written permission. This report sets forth our findings solely with respect to the test samples identified herein. The results set forth in this report are not indicative or representative of the quality or characteristics of the lot from which a test sample was taken or any similar or identical product unless specifically and expressly noted. Our report includes all of the tests requested by you and the results thereof based upon the information that you provided to us. You have 60 days from date of issuance of this report to notify us of any material error or omission caused by our negligence, provided, however, that such notice shall be in writing and shall specifically address the issue you wish to raise. A failure to raise such issue within the prescribed time shall constitute your unqualified acceptance of the completeness of this report, the tests conducted and the correctness of the report contents. Unless specific mention, The uncertainty of measurement has been explicitly taken into account to declare the compliance or non-compliance to the specification.

**Table of contents**

<b>RELEASE CONTROL RECORD .....</b>	<b>4</b>
<b>1. SUMMARY OF TEST RESULTS .....</b>	<b>5</b>
1.1 MEASUREMENT UNCERTAINTY .....	5
<b>2. GENERAL INFORMATION .....</b>	<b>6</b>
2.1 GENERAL DESCRIPTION OF EUT .....	6
2.2 DESCRIPTION OF TEST MODES .....	7
2.2.1 TEST MODE APPLICABILITY AND TESTED CHANNEL DETAIL .....	8
2.3 DUTY CYCLE OF TEST SIGNAL .....	11
2.4 DESCRIPTION OF SUPPORT UNITS .....	12
2.5 GENERAL DESCRIPTION OF APPLIED STANDARDS .....	13
<b>3. TEST TYPES AND RESULTS .....</b>	<b>14</b>
3.1 RADIATED EMISSION AND BAND-EDGE MEASUREMENT .....	14
3.1.1 LIMITS OF RADIATED EMISSION AND BAND-EDGE MEASUREMENT .....	14
3.1.2 LIMITS OF UNWANTED EMISSION OUT OF THE RESTRICTED BANDS .....	14
3.1.3 TEST INSTRUMENTS .....	15
3.1.4 TEST PROCEDURES .....	16
3.1.5 DEVIATION FROM TEST STANDARD .....	16
3.1.6 TEST SETUP .....	17
3.1.7 TEST RESULTS .....	19
3.2 CONDUCTED EMISSION MEASUREMENT .....	39
3.2.1 LIMITS OF CONDUCTED EMISSION MEASUREMENT .....	39
3.2.2 TEST INSTRUMENTS .....	39
3.2.3 TEST PROCEDURES .....	40
3.2.4 DEVIATION FROM TEST STANDARD .....	40
3.2.5 TEST SETUP .....	40
3.2.6 EUT OPERATING CONDITIONS .....	40
3.2.7 TEST RESULTS .....	41
3.3 TRANSMIT POWER MEASUREMENT .....	43
3.3.1 LIMITS OF TRANSMIT POWER MEASUREMENT .....	43
3.3.2 TEST SETUP .....	43
3.3.3 TEST INSTRUMENTS .....	44
3.3.4 TEST PROCEDURE .....	44

3.3.5	DEVIATION FROM TEST STANDARD .....	45
3.3.6	EUT OPERATING CONDITIONS .....	45
3.3.7	TEST RESULTS .....	45
3.4	PEAK POWER SPECTRAL DENSITY MEASUREMENT .....	55
3.4.1	LIMITS OF PEAK POWER SPECTRAL DENSITY MEASUREMENT .....	55
3.4.2	TEST SETUP .....	55
3.4.3	TEST INSTRUMENTS .....	55
3.4.4	TEST PROCEDURES .....	55
3.4.5	DEVIATION FROM TEST STANDARD .....	56
3.4.6	EUT OPERATING CONDITIONS .....	56
3.4.7	TEST RESULTS .....	57
3.5	FREQUENCY STABILITY .....	65
3.5.1	LIMITS OF FREQUENCY STABILITY MEASUREMENT .....	65
3.5.2	TEST SETUP .....	65
3.5.3	TEST INSTRUMENTS .....	65
3.5.4	TEST PROCEDURE .....	66
3.5.5	DEVIATION FROM TEST STANDARD .....	66
3.5.6	EUT OPERATING CONDITION .....	66
3.5.7	TEST RESULTS .....	67
<b>4.</b>	<b>PHOTOGRAPHS OF THE TEST CONFIGURATION .....</b>	<b>70</b>
<b>5.</b>	<b>APPENDIX A – MODIFICATIONS RECORDERS FOR ENGINEERING CHANGES .....</b>	<b>71</b>
<b>6.</b>	<b>APPENDIX B – INFORMATION ON THE TESTING LABORATORIES.....</b>	<b>72</b>

**Release control record**

<b>Issue no.</b>	<b>Reason for change</b>	<b>Date issued</b>
HP191107DC010-FRL	Original release.	Dec. 17, 2019

## 1. Summary of test results

The EUT has been tested according to the following specifications:

<b>FCC part 15, subpart e (section 15.407 under new rule)</b>			
ANSI C63.10:2013			
Standard section	Test type	Result	Remark
15.407(b)(6)	AC Power Conducted Emissions	PASS	Meet the requirement of limit.
15.407(b) (1/2/3/4/6)	Radiated Emissions & Band Edge Measurement	PASS	Meet the requirement of limit.
15.407(b) (1/2/3)	Emission bandwidth	PASS	Meet the requirement of limit.
15.407(a)(1/2/3)	Max Average Transmit Power	PASS	Meet the requirement of limit.
15.407(a)(1/2/3)	Peak Power Spectral Density	PASS	Meet the requirement of limit.
15.407(g)	Frequency Stability	PASS	Meet the requirement of limit.
15.203	Antenna Requirement	PASS	Meet the requirement

### 1.1 Measurement uncertainty

Where relevant, the following measurement uncertainty levels have been estimated for tests performed on the EUT as specified in CISPR 16-4-2:

Measurement	Frequency	Uncertainty
Conducted emissions	150kHz ~ 30MHz	2.66 dB
Radiated emissions	9KHz ~ 30MHz	2.90dB
	30MHz ~ 1000MHz	3.47 dB
	1GHz ~ 18GHz	4.84 dB
	18GHz ~ 40GHz	4.62 dB

This uncertainty represents an expanded uncertainty expressed at approximately the 95% confidence level using a coverage factor of  $k = 2$ .

**2. General information**

**2.1 General description of EUT**

Product name	wireless module
Brand Name	N/A
Model name.	AZ720
Series Model	N/A
FCC ID number	2ACYT-AZ720
Power supply	DC12V from DC port input
Status of EUT	Engineeringprototype
Modulation technology	OFDM
Modulation type	256QAM, 64QAM, 16QAM, QPSK, BPSK
Transfer rate	802.11a: 54.0/ 48.0/ 36.0/ 24.0/ 18.0/ 12.0/ 9.0/ 6.0Mbps 802.11n: up to 300.0Mbps 802.11ac : up to 867Mbps
Operating frequency	5180~5240MHz, 5745~5825MHz
Number of channel	See the section 2.2
Conducted output power	14.57dBm for 5150 ~ 5250MHz (Maximum AVG Power) 17.01dBm for 5725 ~ 5850MHz (Maximum AVG Power)
Antenna type& Antenna Gain	5180 ~ 5240MHz: PCB antenna with 7dBi gain 5745 ~ 5825MHz: PCB antenna with 7dBi gain
Antenna connector	I-PEX
Accessory Device	N/A
Software/Firmware Version	MP-Tool-v3.4
EUT Category	Mobile and Portable client device

**Note:**

1. For a more detailed features description, please refer to the manufacturer’s specifications or the user’s manual.
2. For the test results, the EUT had been tested with all conditions. But only the worst case was shown in test report.
3. Please refer to the EUT photo document for detailed product photo.
4. The EUT incorporates a MIMO function. The WLAN function supports CDD mode with dual antenna transmission and dual antenna reception.

Support mode	Transmit and receive mode	Transmit and Receive Chain
802.11a	MIMO	2TX,2RX
802.11n HT20	MIMO	2TX,2RX
802.11n HT40	MIMO	2TX,2RX
802.11ac VHT20	MIMO	2TX,2RX
802.11ac VHT40	MIMO	2TX,2RX
802.11ac VHT80	MIMO	2TX,2RX

\*The modulation and bandwidth are similar for 802.11n for 20MHz / 40MHz and 802.11ac mode for 20MHz/ 40MHz, therefore investigated worst case to representative mode in test report.

## 2.2 Description of test modes

### For 5150 ~ 5250MHz

4 channels are provided for 802.11a, 802.11a c 20MHz, 802.11n (20MHz):

Channel	Frequency	Channel	Frequency
36	5180 MHz	40	5200 MHz
44	5220 MHz	48	5240 MHz

2 channels are provided for 802.11a c 40MHz, 802.11n (40MHz):

Channel	Frequency	Channel	Frequency
38	5190 MHz	46	5230 MHz

1 channel is provided for 802.11ac (80MHz):

Channel	Frequency	Channel	Frequency
42	5210MHz	--	--

### For 5725 ~ 5850MHz

5 channels are provided for 802.11a, 802.11a c 20MHz, 802.11n (20MHz):

Channel	Frequency	Channel	Frequency
149	5745MHz	153	5765MHz
157	5785MHz	161	5805MHz
165	5825MHz	--	--

2 channels are provided for 802.11a c 40MHz, 802.11n (40MHz):

Channel	Frequency	Channel	Frequency
151	5755MHz	159	5795MHz

1 channel is provided for 802.11ac (80MHz):

Channel	Frequency	Channel	Frequency
155	5775MHz	--	--

**2.2.1 Test mode applicability and tested channel detail**

EUT Configure mode	Applicable test items				Description
	RE≥1G	RE≤1G	PLC	APCM	
802.11a	√	√	√	√	<b>Fully test</b>
802.11n HT20	√	√	√	√	<b>Fully test</b>
802.11n HT40	√	√	√	√	<b>Fully test</b>
802.11ac VHT20	√	√	√	√	Power check
802.11ac VHT40	√	√	√	√	Power check
802.11ac VHT80	√	√	√	√	<b>Fully test</b>
<b>Where:</b> RE≥1G: Radiated Emission above 1GHz RE≤1G: Radiated Emission below 1GHz PLC: Power Line Conducted Emission APCM: Antenna Port Conducted Measurement					

**Radiated Emission:** The EUT had been pre-tested on the positioned of each 3 axis.

Pretest mode:802.11a, Channel 38 transmitting.

The worst case was found when positioned on **X-plane**.

X-plane	worst case
Y-plane	-
Z-plane	-

**Antenna Transmitter technique:**

EUT Configure mode	SISO	SISO	MIMO	Description
	Ant 0	Ant 0	Ant 0+Ant 1	
802.11a, CH36	√	√	<b>Worst case mode</b>	<b>Max. field strength check</b> To determine the worst-case Transmitter mode
802.11n (20MHz)	√	√		
802.11n (20MHz)	-	-	√	<b>Max. conducted power check</b> To determine the worst-case mode
802.11ac (20MHz)	-	-	√	
802.11n (40MHz)	-	-	√	
802.11ac (40MHz)	-	-	√	



**Radiated emission test (above 1GHz):**

- Pre-Scan has been conducted to determine the worst-case mode from all possible combinations between available modulations, data rates and antenna ports (if EUT with antenna diversity architecture).
- Following channel(s) was (were) selected for the final test as listed below.

EUT configure mode	Worst position	Freq. Band (MHz)	Antenna Transmitter technique	Tested channel	Modulation technology	Modulation type	Data rate (Mbps)
802.11a	Z-plane	5150-5250	MIMO	36, 40, 48	OFDM	BPSK	6.0
802.11n (20MHz)	Z-plane		MIMO	36, 40, 48	OFDM	BPSK	6.5
802.11n (40MHz)	Z-plane		MIMO	38, 46	OFDM	BPSK	13.5
802.11ac 80MHz	Z-plane		MIMO	42	OFDM	BPSK	V0
802.11a	Z-plane	5725-5850	MIMO	149, 157, 165	OFDM	BPSK	6.0
802.11n (20MHz)	Z-plane		MIMO	149, 157, 165	OFDM	BPSK	MCS0
802.11n (40MHz)	Z-plane		MIMO	151, 159	OFDM	BPSK	MCS0
802.11ac 80MHz	Z-plane		MIMO	155	OFDM	BPSK	V0

**Radiated emission test (below 1GHz):**

- Following channel(s) was (were) selected for the final test as listed below.

EUT Configure mode	Worst Position	Freq. Band (MHz)	Antenna Transmitter technique	Worst case channel	Modulation technology	Modulation type	Data rate (Mbps)
802.11a	Z-plane	5150-5250 5725-5850	MIMO	<b>159</b>	OFDM	BPSK	6.0

**Power line conducted emission test:**

- Pre-Scan has been conducted to determine the worst-case mode from all possible combinations between available modulations, data rates and antenna ports (if EUT with antenna diversity architecture).
- Following channel(s) was (were) selected for the final test as listed below.

EUT Configure mode	Worst Position	Freq. Band (MHz)	Antenna Transmitter technique	Tested channel	Modulation technology	Modulation type	Data rate (Mbps)
802.11a	-	5150-5250 5725-5850	MIMO	<b>159</b>	OFDM	BPSK	6.0

**Antenna port conducted measurement:**

- This item includes all test value of each mode, but only includes spectrum plot of worst value of each mode.
- Pre-Scan has been conducted to determine the worst-case mode from all possible combinations between available modulations, data rates and antenna ports (if EUT with antenna diversity architecture).
- Following channel(s) was (were) selected for the final test as listed below.

EUT configure mode	Antenna Transmitter technique	Freq. Band (MHz)	Tested channel	Modulation technology	Modulation type	Data rate (Mbps)
802.11a	MIMO	5150-5250	36, 40, 48	OFDM	BPSK	6.0
802.11n (20MHz)	MIMO		36, 40, 48	OFDM	BPSK	6.5
802.11n (40MHz)	MIMO		38, 46	OFDM	BPSK	13.5
802.11ac 80MHz	MIMO		42	OFDM	BPSK	V0
802.11a	MIMO	5725-5850	149, 157, 165	OFDM	BPSK	6.0
802.11n (20MHz)	MIMO		149, 157, 165	OFDM	BPSK	MCS0
802.11n (40MHz)	MIMO		151, 159	OFDM	BPSK	MCS0
802.11ac 80MHz	MIMO		155	OFDM	BPSK	V0

**Test condition:**

Applicable to	Environmental conditions	Input power	Tested by
RE<1G	22.2deg. C, 50%RH	DC 12V From Adapter	Tank Tan
RE≥1G	22.2deg. C, 50%RH	DC 12V From Adapter	Tank Tan
PLC	22.4deg. C, 50%RH	DC 12V From Adapter	Tank Tan
APCM	22.6deg. C, 50%RH	DC 12V From Adapter	Harry Li

### 2.3 Duty cycle of test signal

#### Duty cycle of test signal < 98%

##### 802.11a

Duty cycle of test signal is  $1.393/1.492=93.33\%$ ,  
 Duty cycle factor =  $10 \cdot \log(1/0.9333)=0.30\text{dB}$

##### 802.11n HT20

Duty cycle of test signal is  $1.305/1.430=91.25\%$ ,  
 Duty cycle factor =  $10 \cdot \log(1/0.9125)=0.40\text{dB}$

##### 802.11n HT40

Duty cycle of test signal is  $0.6447/0.7195=89.60\%$ ,  
 Duty cycle factor =  $10 \cdot \log(1/0.8960)=0.48\text{dB}$

##### 802.11ac VHT80

Duty cycle of test signal is  $0.3217/0.4053=79.37\%$ ,  
 Duty cycle factor =  $10 \cdot \log(1/0.8295)=1.00\text{ dB}$

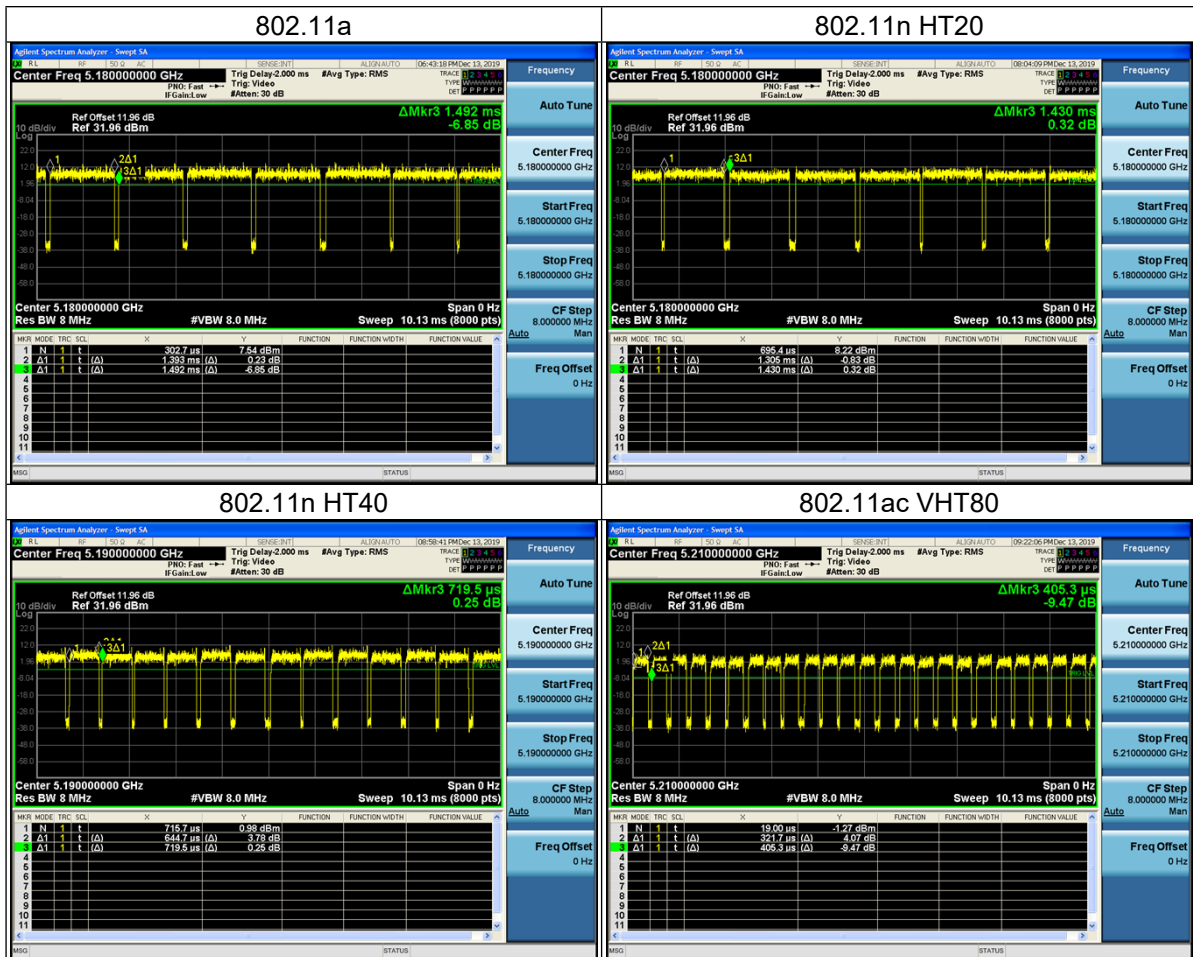

## 2.4 Description of support units

The EUT has been tested as an independent unit together with other necessary accessories or support units. The following support units or accessories were used to form a representative test configuration during the tests.

No.	Product	Brand	Model no.	Serial no.	FCC ID
1	Notebook	Lenovo	TP0093A	PF-12HMBU	N/A
2	Mouse	DELL	MS111-L	CN-09RRC7-44751-0C6-04TR	N/A
3	Adapter	ASUS	DC1202000	N/A	N/A

No.	Description of the above support units
1	AC Line: Unshielded, Detachable 1.8m; DC Line: Unshielded, Detachable 1.8m;
2	USB Line: Unshielded, Detachable 1.8m.
3	DC Line: Un-shielding 1.5m
4	RJ45 Line: Un-shielding 10m

### Configuration of System under Test:

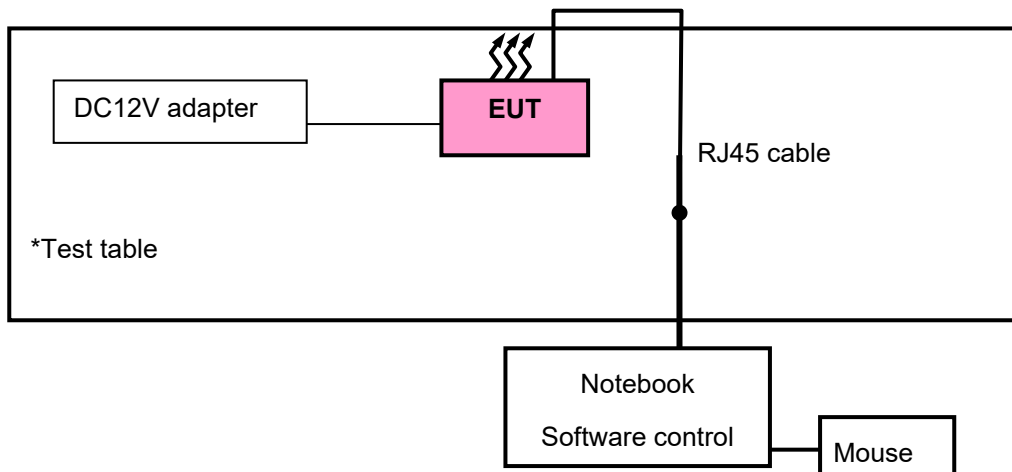

Installed the EUT in the PC and set the EUT under transmission condition continuously at specific channel frequency.

## 2.5 General description of applied standards

The EUT is a RF Product. According to the specification of the EUT declared by the manufacturer, it must comply with the requirements of the following standards:

**FCC Part 15, Subpart E (15.407)**  
**789033 D02 General UNII Test Procedures New Rules v01r03**  
**KDB 662911 D01 v02r01**  
ANSI C63.10-2013

(All test items have been performed and recorded as per the above standards) .

### Note:

The EUT is also considered as a kind of computer peripheral, because the connection to computer is necessary for typical use. It has been verified to comply with the requirements of FCC Part 15.Subpart B. Class B (DoC). The test report has been issued separately.

### 3. Test types and results

#### 3.1 Radiated emission and band-edge measurement

##### 3.1.1 Limits of radiated emission and band-edge measurement

Radiated emissions which fall in the restricted bands must comply with the radiated emission limits specified as below table:

Frequencies (MHz)	Field strength (micro volts/meter)	Measurement distance(meters)
0.009 ~ 0.490	2400/F(kHz)	300
0.490 ~ 1.705	24000/F(kHz)	30
1.705 ~ 30.0	30	30
30 ~ 88	100	3
88 ~ 216	150	3
216 ~ 960	200	3
Above 960	500	3

**Note:**

1. The lower limit shall apply at the transition frequencies.
2. Emission level (dBuV/m) = 20 log Emission level (uV/m).
3. For frequencies above 1000MHz, the field strength limits are based on average detector, however, the peak field strength of any emission shall not exceed the maximum permitted average limits, specified above by more than 30dB under any condition of modulation.

##### 3.1.2 Limits of unwanted emission out of the restricted bands

Applicable to	Limit	
789033 D02 General UNII Test Procedures New Rules v01r03	Field strength at 3m	
	PK: 74 (dBµV/m)	AV: 54 (dBµV/m)
Applicable to	EIRP Limit	Equivalent field strength at 3m
15.407(b)(1)	PK: -27 (dBm/MHz)	PK: 68.2 (dBµV/m)
15.407(b)(2)		
15.407(b)(3)		
15.407(b)(4)	See Note*	See Note*

**Note\*:For transmitters operating in the 5.725-5.85 GHz band:**

Section 15.407(b)(4) specifies the unwanted emissions limit for the U-NII-3 band. A band emissions mask is specified in Section 15.407(b)(4)(i). An alternative to the band emissions mask is specified in Section 15.407(b)(4)(ii). The alternative limits are based on the highest antenna gain specified in the filing. There are also marketing and importation restrictions for the alternative limit.

15.407(b)(4)(i) All emissions shall be limited to a level of -27 dBm/MHz at 75 MHz or more above or below the band edge increasing linearly to 10 dBm/MHz at 25 MHz above or below the band edge, and from 25 MHz above or below the band edge increasing linearly to a level of 15.6 dBm/MHz at 5 MHz above or below the band edge, and from 5 MHz above or below the band edge increasing linearly to a level of 27 dBm/MHz at the band edge.

The following formula is used to convert the equipment isotropic radiated power (eirp) to field strength:

$$E = \frac{1000000\sqrt{30P}}{3} \mu\text{V/m, where P is the eirp (Watts).}$$

### 3.1.3 Test instruments

Description & Manufacturer	Model No.	Serial No.	Date of Calibration	Due Date of Calibration
EMI Test Receiver Rohde&Schwarz	ESCI 7	100962	2019-07-16	2020-07-15
Broadband antenna Schwarzbeck	VULB 9168	00937	2019-10-18	2020-10-17
3m Semi-anechoic Chamber MAORUI	9m*6m*6m	NSEMC003	2018-10-20	2020-10-19
Signal Amplifier Com-power	PAM-103	18020051	2019-10-18	2020-10-17
Attenuator Rohde&Schwarz	TS2GA-6dB	18101101	N/A	N/A
Test software FARAD	FARAD	EZ_EMCV1.1.4.2	N/A	N/A
Fixed Attenuator Mini-Circuits	MDCS18N-10	MDCS18N-10-01	2019-10-18	2020-10-17
Loop Antenna	HLA 6121	45745	2019-10-18	2020-10-17
Preamplifier EMCI	EMC001340	980201	2019-10-18	2020-10-17
Digital Multimeter FLUKE	15B+	43512617WS	2019-10-18	2020-10-17
Horn Antenna Schwarzbeck	BBHA 9170	01959	2019-10-18	2020-10-17
Spectrum Analyzer Rohde&Schwarz	FSV-40N	101783	2019-10-18	2020-10-17
Broadband Coaxial Preamplifier Schwarzbeck	BBV 9718	00025	2019-10-18	2020-10-17
Horn Antenna Schwarzbeck	BBHA 9170	BBHA9170242	2019-10-18	2020-10-17
Pre-Amplifier EMCI	EMC 184045	980102	2019-10-18	2020-10-17
Spectrum Keysight	N9020A	MY51240612	2019-10-18	2020-10-17
Antenna Tower MF	MFA-440H	NA	NA	NA
Turn Table MF	MFT-201SS	NA	NA	NA
Antenna Tower&Turn Table Controller MF	MF-7802	NA	NA	NA

- Note:
1. The calibration interval of the above test instruments is 12 months and the calibrations are traceable to CEPREI/CHINA.
  2. The test was performed in Chamber 1.

### 3.1.4 Test procedures

- a. The EUT was placed on the top of a rotating table 1.5 meters(above 1GHz) and 0.8 meters(below 1GHz) above the ground at a 3 meters semi-anechoic chamber. The table was rotated 360 degrees to determine the position of the highest radiation.
- b. The EUT was set 3 meters away from the interference-receiving antenna, which was mounted on the top of a variable-height antenna tower.
- c. The antenna is a broadband antenna, and its height is varied from one meter to four meters above the ground to determine the maximum value of the field strength. Both horizontal and vertical polarizations of the antenna are set to make the measurement.
- d. For each suspected emission, the EUT was arranged to its worst case and then the antenna was tuned to heights from 1 meter to 4 meters and the rotatable table was turned from 0 degrees to 360 degrees to find the maximum reading.
- e. The test-receiver system was set to Peak Detect Function and Specified Bandwidth with Maximum Hold Mode.
- f. If the emission level of the EUT in peak mode was 10dB lower than the limit specified, then testing could be stopped and the peak values of the EUT would be reported. Otherwise the emissions that did not have 10dB margin would be re-tested one by one using peak, quasi-peak or average method as specified and then reported in a data sheet.
- g. For below 30MHz, a loop antenna with its vertical plane is place 3m from the EUT and rotated about its vertical axis for maximum response at each azimuth about the EUT. And the centre of the loop shall be 1m above the ground.
- h. If the emission level of the EUT in peak mode was lower than the limit specified, then testing could be stopped and the peak values of the EUT would be reported. Otherwise the emissions would be re-tested one by one using peak, quasi-peak or average method as specified and then reported in a data sheet.

#### Note:

1. The resolution bandwidth and video bandwidth of test receiver/spectrum analyzer is 120kHz for Quasi-peak detection at frequency below 1GHz.
2. The resolution bandwidth of test receiver/spectrum analyzer is 1MHz and video bandwidth is 3MHz for Peak detection at frequency above 1GHz.
3. The resolution bandwidth of test receiver/spectrum analyzer is 1MHz and the video bandwidth is  $\geq 1/T$  (Duty cycle < 98%) or 10Hz(Duty cycle > 98%) for Average detection (AV) at frequency above 1GHz.
4. All modes of operation were investigated and the worst-case emissions are reported.

### 3.1.5 Deviation from test standard

No deviation.



### 3.1.6 Test setup

Below 30MHz test setup:

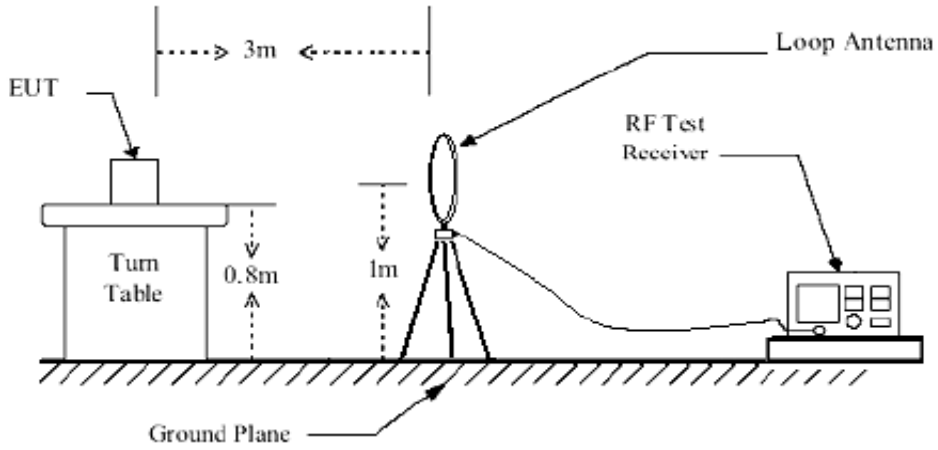

Below 1GHz test setup:

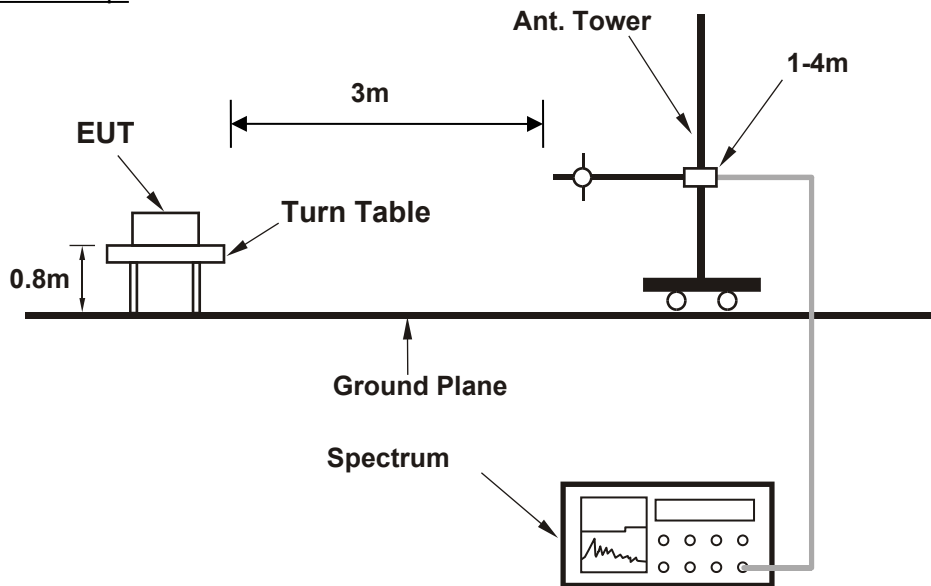

Above 1GHz test setup:

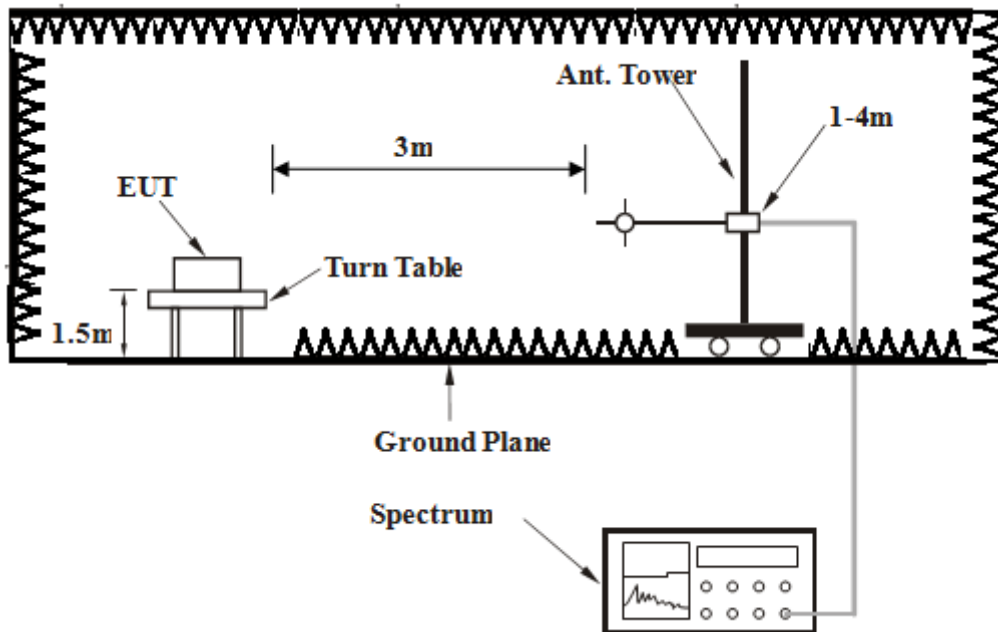

**Note:** For the actual test configuration, please refer to the attached file (Test Setup Photo).

**\*EUT operating condition:**

Installed the EUT in the PC and set the EUT under transmission condition continuously at specific channel frequency.

### 3.1.7 Test results

#### Below 1GHz worst-case data

\*9kHz ~ 30MHz Data:

The amplitude of spurious emissions attenuated more than 20dB below the permissible value is not required to be report.

\*30MHz ~ 1GHz Worst-Case Data:

EUT Test Condition	802.11a TX		
Test Channel	Channel 159	Frequency Range	30MHz ~ 1GHz
Input Power	DC 12V from adapter	Detector Function	Peak (PK) Quasi-peak (QP)
Environmental Conditions	25deg. C, 65%RH	Tested By	Tank tan

Antenna Polarity & test distance: horizontal at 3 m

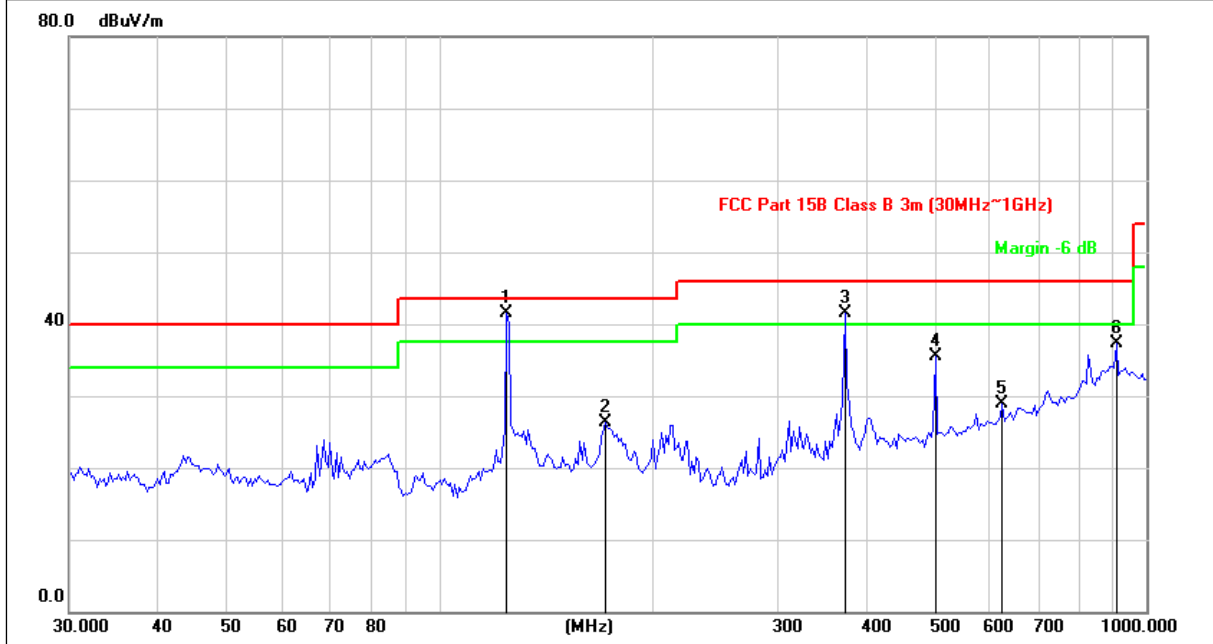

No.	Frequency (MHz)	Reading (dBuV)	Factor (dB)	Emission Level (dBuV/m)	Limit (dBuV/m)	Margin (dB)	Detector	Antenna Height (cm)	Table Angle (Degree)
1	124.5690	56.21	-14.68	41.53	43.50	-1.97	QP	200	143
2	171.9945	39.53	-13.27	26.26	43.50	-17.24	QP	200	174
3	374.6225	51.52	-9.93	41.59	46.00	-4.41	QP	200	184
4	502.9395	43.12	-7.57	35.55	46.00	-10.45	QP	200	296
5	625.0779	33.42	-4.54	28.88	46.00	-17.12	QP	100	229
6	906.4823	35.76	1.51	37.27	46.00	-8.73	QP	200	214

Remarks:

1. Emission level (dBuV/m) = Raw Value (dBuV) + Correction Factor (dB/m).
2. Factor (dB/m) = Antenna Factor (dB/m) + Cable Factor (dB).
3. The other emission levels were very low against the limit.
4. Margin value = Emission level – Limit value.

EUT Test Condition	802.11a TX		
Channel	Channel 159	Frequency Range	30MHz ~ 1GHz
Input Power	DC12V from DC port input	Detector Function	Peak (PK) Quasi-peak (QP)
Environmental Conditions	25deg. C, 65%RH	Tested By	Tank Tan

Antennal Polarity & test distance: vertical at 3 m

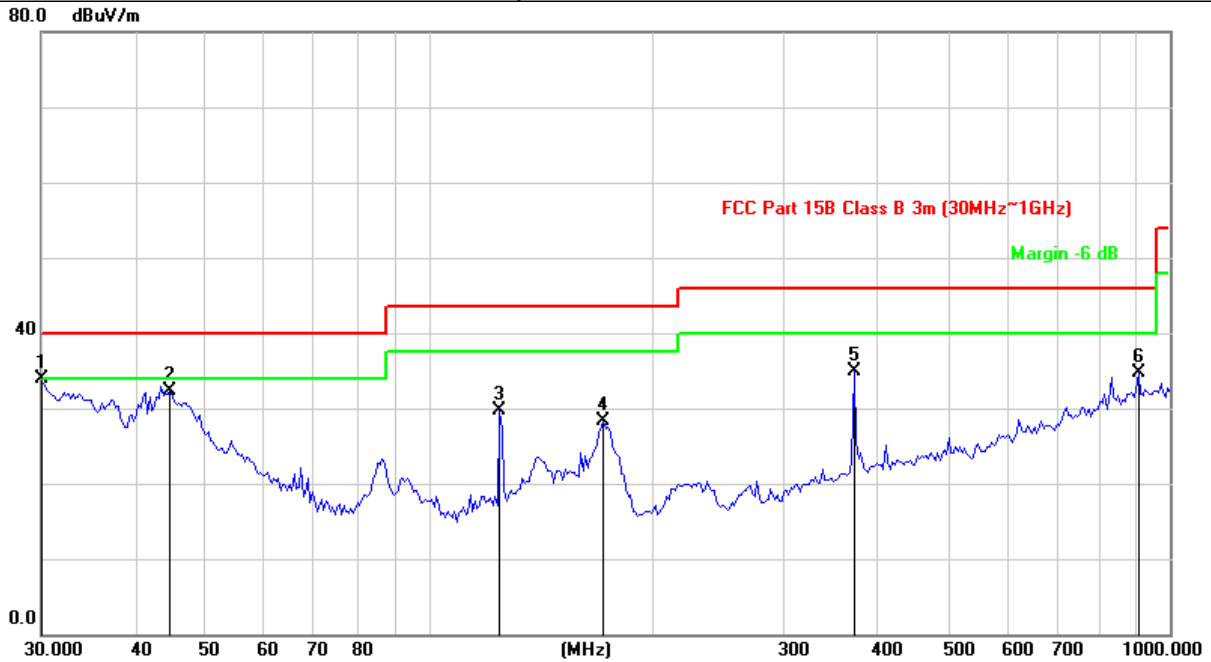

No.	Frequency (MHz)	Reading (dBuV)	Factor (dB)	Emission Level (dBuV/m)	Limit (dBuV/m)	Margin (dB)	Detector	Antenna Height (cm)	Table Angle (Degree)
1	30.0000	51.00	-17.12	33.88	40.00	-6.12	QP	100	214
2	44.7433	46.88	-14.66	32.22	40.00	-7.78	QP	100	196
3	124.5690	44.41	-14.68	29.73	43.50	-13.77	QP	100	263
4	171.9946	41.51	-13.27	28.24	43.50	-15.26	QP	100	128
5	374.6225	44.80	-9.93	34.87	46.00	-11.13	QP	100	130
6	906.4823	33.16	1.51	34.67	46.00	-11.33	QP	100	229

Remarks:

1. Emission level (dBuV/m) = Raw Value (dBuV) + Correction Factor (dB/m).
2. Correction Factor (dB/m) = Antenna Factor (dB/m) + Cable Factor (dB).
3. The other emission levels were very low against the limit.
4. Margin value = Emission level – Limit value.

**Above 1GHz data**
**802.11a**

Test Channel	TX Channel 36	Detector Function	Peak (PK) Average (AV)
Frequency Range	1GHz ~ 40GHz		

Antennal Polarity & Test Distance: Horizontal at 3 m									
No.	Frequency (MHz)	Reading (dBuV)	Factor (dB)	Emission Level (dBuV/m)	Limit (dBuV/m)	Margin (dB)	Detector	Antenna Height (cm)	Table Angle (Degree)
1	5150.000	45.89	7.54	53.43	74.00	-20.57	peak	123	327
2	5150.000	27.82	7.54	35.36	54.00	-18.64	AVG	123	327
3 *	5180.000	98.07	8.49	106.56			peak	123	327
4 *	5180.000	82.75	8.49	91.24			AVG	123	327
5	10360.000	35.18	17.87	53.05	68.30	-15.25	peak	100	218
6	10360.000	21.26	17.87	39.13	54.00	-14.87	AVG	100	218
7	15540.000	37.05	22.25	59.30	74.00	-14.70	peak	163	224
8	15540.000	21.15	22.25	43.40	54.00	-10.60	AVG	163	224
Antennal Polarity & Test Distance: Vertical at 3 m									
No.	Frequency (MHz)	Reading (dBuV)	Factor (dB)	Emission Level (dBuV/m)	Limit (dBuV/m)	Margin (dB)	Detector	Antenna Height (cm)	Table Angle (Degree)
1	5150.000	38.00	7.54	45.54	74.00	-28.46	peak	355	206
2	5150.000	24.57	7.54	32.11	54.00	-21.89	AVG	355	206
3 *	5180.000	91.35	8.49	99.84			peak	355	206
4 *	5180.000	76.08	8.49	84.57			AVG	355	206
5	10360.000	34.86	17.87	52.73	68.30	-15.57	peak	134	204
6	10360.000	21.34	17.87	39.21	54.00	-14.79	AVG	134	204
7	15540.000	36.96	22.25	59.21	74.00	-14.79	peak	147	183
8	15540.000	21.17	22.25	43.42	54.00	-10.58	AVG	147	183

1-Emission level (dBuV/m) = Raw Value (dBuV) + Correction Factor (dB/m).

2-Correction Factor (dB/m) = Antenna Factor (dB/m) + Cable Factor (dB).

3-The other emission levels were very low against the limit.

4-Margin value = Emission level – Limit value.

5- " \* ": Fundamental frequency.

Test Channel	TX Channel 40	Detector Function	Peak (PK) Average (AV)
Frequency Range	1GHz ~ 40GHz		

Antennal Polarity & Test Distance: Horizontal at 3 m									
No.	Frequency (MHz)	Reading (dBuV)	Factor (dB)	Emission Level (dBuV/m)	Limit (dBuV/m)	Margin (dB)	Detector	Antenna Height (cm)	Table Angle (Degree)
1	5150.000	33.42	7.54	40.96	74.00	-33.04	peak	101	329
2	5150.000	22.05	7.54	29.59	54.00	-24.41	AVG	101	329
3 *	5200.000	97.05	9.12	106.17			peak	101	329
4 *	5200.000	81.74	9.12	90.86			AVG	101	329
5	10400.000	34.60	18.00	52.60	68.30	-15.70	peak	116	197
6	10400.000	23.92	18.00	41.92	54.00	-12.08	AVG	116	197
7	15600.000	35.69	22.23	57.92	74.00	-16.08	peak	150	211
8	15600.000	20.73	22.23	42.96	54.00	-11.04	AVG	150	211
Antennal Polarity & Test Distance: Vertical at 3 m									
No.	Frequency (MHz)	Reading (dBuV)	Factor (dB)	Emission Level (dBuV/m)	Limit (dBuV/m)	Margin (dB)	Detector	Antenna Height (cm)	Table Angle (Degree)
1	5150.000	36.48	7.54	44.02	74.00	-29.98	peak	348	217
2	5150.000	21.26	7.54	28.80	54.00	-25.20	AVG	348	217
3 *	5200.000	90.12	9.12	99.24			peak	348	217
4 *	5200.000	74.85	9.12	83.97			AVG	348	217
5	10400.000	32.37	18.00	50.37	68.30	-17.93	peak	136	193
6	10400.000	22.39	18.00	40.39	54.00	-13.61	AVG	136	193
7	15600.000	33.42	22.23	55.65	74.00	-18.35	peak	120	175
8	15600.000	20.65	22.23	42.88	54.00	-11.12	AVG	120	175

1-Emission level (dBuV/m) = Raw Value (dBuV) + Correction Factor (dB/m).

2-Correction Factor (dB/m) = Antenna Factor (dB/m) + Cable Factor (dB).

3-The other emission levels were very low against the limit.

4-Margin value = Emission level – Limit value.

5- " \* ": Fundamental frequency.

Test Channel	TX Channel 48	Detector Function	Peak (PK) Average (AV)
Frequency Range	1GHz ~ 40GHz		

Antennal Polarity & Test Distance: Horizontal at 3 m									
No.	Frequency (MHz)	Reading (dBuV)	Factor (dB)	Emission Level (dBuV/m)	Limit (dBuV/m)	Margin (dB)	Detector	Antenna Height (cm)	Table Angle (Degree)
1 *	5240.000	99.04	7.97	107.01			peak	103	335
2 *	5240.000	83.71	7.97	91.68			AVG	103	335
3	10480.000	33.90	18.26	52.16	68.30	-16.14	peak	149	282
4	10480.000	22.82	18.26	41.08	54.00	-12.92	AVG	149	282
5	15720.000	35.34	22.19	57.53	74.00	-16.47	peak	127	176
6	15720.000	20.69	22.19	42.88	54.00	-11.12	AVG	127	176
Antennal Polarity & Test Distance: Vertical at 3 m									
No.	Frequency (MHz)	Reading (dBuV)	Factor (dB)	Emission Level (dBuV/m)	Limit (dBuV/m)	Margin (dB)	Detector	Antenna Height (cm)	Table Angle (Degree)
1 *	5240.000	92.31	7.97	100.28			peak	372	225
2 *	5240.000	77.17	7.97	85.14			AVG	372	225
3	10480.000	34.93	18.26	53.19	68.30	-15.11	peak	100	217
4	10480.000	22.48	18.26	40.74	54.00	-13.26	AVG	100	217
5	15720.000	35.28	22.19	57.47	74.00	-16.53	peak	123	188
6	15720.000	20.66	22.19	42.85	54.00	-11.15	AVG	123	188

1-Emission level (dBuV/m) = Raw Value (dBuV) + Correction Factor (dB/m).

2-Correction Factor (dB/m) = Antenna Factor (dB/m) + Cable Factor (dB).

3-The other emission levels were very low against the limit.

4-Margin value = Emission level – Limit value.

5- " \* ": Fundamental frequency.

Test Channel	TX Channel 149	Detector Function	Peak (PK) Average (AV)
Frequency Range	1GHz ~ 40GHz		

Antennal Polarity & Test Distance: Horizontal at 3 m									
No.	Frequency (MHz)	Reading (dBuV)	Factor (dB)	Emission Level (dBuV/m)	Limit (dBuV/m)	Margin (dB)	Detector	Antenna Height (cm)	Table Angle (Degree)
1* #	5725.000	46.78	6.96	53.74	122.20	-68.46	peak	100	90
2	5745.000	102.66	6.99	109.65			peak	100	90
3 *	5745.000	86.35	6.99	93.34			AVG	100	90
4	11490.000	32.73	19.77	52.50	74.00	-21.50	peak	142	217
5	11490.000	19.93	19.77	39.70	54.00	-14.30	AVG	142	217
6	17235.000	33.31	26.17	59.48	68.30	-8.82	peak	129	183
7	17235.000	20.86	26.17	47.03	54.00	-6.97	AVG	129	183
Antennal Polarity & Test Distance: Vertical at 3 m									
No.	Frequency (MHz)	Reading (dBuV)	Factor (dB)	Emission Level (dBuV/m)	Limit (dBuV/m)	Margin (dB)	Detector	Antenna Height (cm)	Table Angle (Degree)
1 #	5725.000	42.59	6.96	49.55	122.20	-72.65	peak	261	238
2	5745.000	94.57	6.99	101.56			peak	261	238
3 *	5745.000	77.52	6.99	84.51			AVG	261	238
4	11490.000	34.52	19.77	54.29	74.00	-19.71	peak	115	298
5	11490.000	19.86	19.77	39.63	54.00	-14.37	AVG	115	298
6	17235.000	36.08	26.17	62.25	68.30	-6.05	peak	100	144
7	17235.000	16.26	26.17	42.43	54.00	-12.57	AVG	100	144

1-Emission level (dBuV/m) = Raw Value (dBuV) + Correction Factor (dB/m).

2-Correction Factor (dB/m) = Antenna Factor (dB/m) + Cable Factor (dB).

3-The other emission levels were very low against the limit.

4-Margin value = Emission level – Limit value.

5- " \* ": Fundamental frequency.

6- " # ": The radiated frequency is out of the restricted band



Test Channel	TX Channel 157	Detector Function	Peak (PK) Average (AV)
Frequency Range	1GHz ~ 40GHz		

Antennal Polarity & Test Distance: Horizontal at 3 m									
No.	Frequency (MHz)	Reading (dBuV)	Factor (dB)	Emission Level (dBuV/m)	Limit (dBuV/m)	Margin (dB)	Detector	Antenna Height (cm)	Table Angle (Degree)
1 #	5725.000	34.78	6.96	41.74	122.20	-80.46	peak	100	104
2 *	5785.000	101.52	7.07	108.59			peak	100	104
3 *	5785.000	85.41	7.07	92.48			AVG	100	104
4	5850.000	33.41	7.20	40.61	122.20	-81.59	peak	100	104
5	11570.000	34.51	19.75	54.26	74.00	-19.74	peak	124	193
6	11570.000	20.02	19.75	39.77	54.00	-14.23	AVG	124	193
7	17355.000	35.24	26.68	61.92	68.30	-6.38	peak	117	228
8	17355.000	20.13	26.68	46.81	54.00	-7.19	AVG	117	228
Antennal Polarity & Test Distance: Vertical at 3 m									
No.	Frequency (MHz)	Reading (dBuV)	Factor (dB)	Emission Level (dBuV/m)	Limit (dBuV/m)	Margin (dB)	Detector	Antenna Height (cm)	Table Angle (Degree)
1 #	5725.000	35.20	6.96	42.16	122.20	-80.04	peak	323	136
2 *	5785.000	93.16	7.07	100.23			peak	323	136
3 *	5785.000	76.07	7.07	83.14			AVG	323	136
4	5850.000	33.73	7.20	40.93	122.20	-81.27	peak	323	136
5	11570.000	35.46	19.75	55.21	74.00	-18.79	peak	185	241
6	11570.000	20.32	19.75	40.07	54.00	-13.93	AVG	185	241
7	17355.000	35.51	26.68	62.19	68.30	-6.11	peak	143	176
8	17355.000	20.10	26.68	46.78	54.00	-7.22	AVG	143	176

1-Emission level (dBuV/m) = Raw Value (dBuV) + Correction Factor (dB/m).

2-Correction Factor (dB/m) = Antenna Factor (dB/m) + Cable Factor (dB).

3-The other emission levels were very low against the limit.

4-Margin value = Emission level – Limit value.

5- " \* ": Fundamental frequency.

6- " # ": The radiated frequency is out of the restricted band

Test Channel	TX Channel 165	Detector Function	Peak (PK) Average (AV)
Frequency Range	1GHz ~ 40GHz		

Antennal Polarity & Test Distance: Horizontal at 3 m									
No.	Frequency (MHz)	Reading (dBuV)	Factor (dB)	Emission Level (dBuV/m)	Limit (dBuV/m)	Margin (dB)	Detector	Antenna Height (cm)	Table Angle (Degree)
1 *	5825.000	104.03	7.15	111.18			peak	100	98
2 *	5825.000	85.95	7.15	93.10			AVG	100	98
3	5850.000	45.48	7.20	52.68	122.20	-69.52	peak	100	98
4	11650.000	34.29	19.72	54.01	74.00	-19.99	peak	138	212
5	11650.000	20.35	19.72	40.07	54.00	-13.93	AVG	138	212
6	17475.000	32.92	27.19	60.11	68.30	-8.19	peak	100	356
7	17475.000	17.13	27.19	44.32	54.00	-9.68	AVG	100	295
Antennal Polarity & Test Distance: Vertical at 3 m									
No.	Frequency (MHz)	Reading (dBuV)	Factor (dB)	Emission Level (dBuV/m)	Limit (dBuV/m)	Margin (dB)	Detector	Antenna Height (cm)	Table Angle (Degree)
1 *	5825.000	95.74	7.15	102.89			peak	254	269
2 *	5825.000	78.31	7.15	85.46			AVG	254	269
3	5850.000	43.41	7.20	50.61	122.20	-71.59	peak	254	269
4	11650.000	32.97	19.72	52.69	74.00	-21.31	peak	113	185
5	11650.000	20.30	19.72	40.02	54.00	-13.98	AVG	113	185
6	17475.000	33.01	27.19	60.20	68.30	-8.10	peak	139	178
7	17475.000	17.07	27.19	44.26	54.00	-9.74	AVG	139	178

1-Emission level (dBuV/m) = Raw Value (dBuV) + Correction Factor (dB/m).

2-Correction Factor (dB/m) = Antenna Factor (dB/m) + Cable Factor (dB).

3-The other emission levels were very low against the limit.

4-Margin value = Emission level – Limit value.

5- " \* ": Fundamental frequency.

11n HT20

Test Channel	TX Channel 36	Detector Function	Peak (PK) Average (AV)
Frequency Range	1GHz ~ 40GHz		

Antennal Polarity & Test Distance: Horizontal at 3 m

No.	Frequency (MHz)	Reading (dBuV)	Factor (dB)	Emission Level (dBuV/m)	Limit (dBuV/m)	Margin (dB)	Detector	Antenna Height (cm)	Table Angle (Degree)
1	5150.000	41.58	7.54	49.12	74.00	-24.88	peak	100	326
2	5150.000	28.32	7.54	35.86	54.00	-18.14	AVG	100	326
3 *	5180.000	97.62	8.49	106.11			peak	100	326
4 *	5180.000	82.04	8.49	90.53			AVG	100	326
5	10360.000	32.45	17.87	50.32	68.30	-17.98	peak	116	242
6	10360.000	24.02	17.87	41.89	54.00	-12.11	AVG	116	242
7	15540.000	33.86	22.25	56.11	74.00	-17.89	peak	100	109
8	15540.000	21.89	22.25	44.14	54.00	-9.86	AVG	100	109

Antennal Polarity & Test Distance: Vertical at 3 m

No.	Frequency (MHz)	Reading (dBuV)	Factor (dB)	Emission Level (dBuV/m)	Limit (dBuV/m)	Margin (dB)	Detector	Antenna Height (cm)	Table Angle (Degree)
1	5150.000	36.62	7.54	44.16	74.00	-29.84	peak	327	215
2	5150.000	23.24	7.54	30.78	54.00	-23.22	AVG	327	215
3 *	5180.000	90.93	8.49	99.42			peak	327	215
4 *	5180.000	75.17	8.49	83.66			AVG	327	215
5	10360.000	33.55	17.87	51.42	68.30	-16.88	peak	108	204
6	10360.000	22.32	17.87	40.19	54.00	-13.81	AVG	108	204
7	15540.000	35.39	22.25	57.64	74.00	-16.36	peak	162	222
8	15540.000	21.82	22.25	44.07	54.00	-9.93	AVG	162	222

1-Emission level (dBuV/m) = Raw Value (dBuV) + Correction Factor (dB/m).

2-Correction Factor (dB/m) = Antenna Factor (dB/m) + Cable Factor (dB).

3-The other emission levels were very low against the limit.

4-Margin value = Emission level – Limit value.

5- " \* ": Fundamental frequency.

Test Channel	TX Channel 40	Detector Function	Peak (PK) Average (AV)
Frequency Range	1GHz ~ 40GHz		

Antennal Polarity & Test Distance: Horizontal at 3 m									
No.	Frequency (MHz)	Reading (dBuV)	Factor (dB)	Emission Level (dBuV/m)	Limit (dBuV/m)	Margin (dB)	Detector	Antenna Height (cm)	Table Angle (Degree)
1	5150.000	36.43	7.54	43.97	74.00	-30.03	peak	104	320
2	5150.000	24.32	7.54	31.86	54.00	-22.14	AVG	104	320
3 *	5200.000	96.61	9.12	105.73			peak	104	320
4 *	5200.000	80.74	9.12	89.86			AVG	104	320
5	10400.000	32.51	18.00	50.51	68.30	-17.79	peak	152	205
6	10400.000	25.62	18.00	43.62	54.00	-10.38	AVG	152	205
7	15600.000	33.61	22.23	55.84	74.00	-18.16	peak	138	164
8	15600.000	21.83	22.23	44.06	54.00	-9.94	AVG	138	164
Antennal Polarity & Test Distance: Vertical at 3 m									
No.	Frequency (MHz)	Reading (dBuV)	Factor (dB)	Emission Level (dBuV/m)	Limit (dBuV/m)	Margin (dB)	Detector	Antenna Height (cm)	Table Angle (Degree)
1	5150.000	36.05	7.54	43.59	74.00	-30.41	peak	351	186
2	5150.000	24.28	7.54	31.82	54.00	-22.18	AVG	351	186
3 *	5200.000	89.62	9.12	98.74			peak	351	186
4 *	5200.000	74.00	9.12	83.12			AVG	351	186
5	10400.000	32.84	18.00	50.84	68.30	-17.46	peak	114	237
6	10400.000	23.15	18.00	41.15	54.00	-12.85	AVG	114	237
7	15600.000	34.12	22.23	56.35	74.00	-17.65	peak	149	255
8	15600.000	21.55	22.23	43.78	54.00	-10.22	AVG	149	255

1-Emission level (dBuV/m) = Raw Value (dBuV) + Correction Factor (dB/m).

2-Correction Factor (dB/m) = Antenna Factor (dB/m) + Cable Factor (dB).

3-The other emission levels were very low against the limit.

4-Margin value = Emission level – Limit value.

5- " \* ": Fundamental frequency.

Test Channel	TX Channel 48	Detector Function	Peak (PK) Average (AV)
Frequency Range	1GHz ~ 40GHz		

Antennal Polarity & Test Distance: Horizontal at 3 m									
No.	Frequency (MHz)	Reading (dBuV)	Factor (dB)	Emission Level (dBuV/m)	Limit (dBuV/m)	Margin (dB)	Detector	Antenna Height (cm)	Table Angle (Degree)
1 *	5240.000	98.76	7.97	106.73			peak	139	284
2 *	5240.000	83.32	7.97	91.29			AVG	139	284
3	10480.000	32.27	18.26	50.53	68.30	-17.77	peak	150	251
4	10480.000	24.85	18.26	43.11	54.00	-10.89	AVG	150	251
5	15720.000	32.63	22.19	54.82	74.00	-19.18	peak	112	163
6	15720.000	20.76	22.19	42.95	54.00	-11.05	AVG	112	163
Antennal Polarity & Test Distance: Vertical at 3 m									
No.	Frequency (MHz)	Reading (dBuV)	Factor (dB)	Emission Level (dBuV/m)	Limit (dBuV/m)	Margin (dB)	Detector	Antenna Height (cm)	Table Angle (Degree)
1 *	5240.000	92.92	7.97	100.89			peak	300	227
2 *	5240.000	76.15	7.97	84.12			AVG	300	227
3	10480.000	33.05	18.26	51.31	68.30	-16.99	peak	100	136
4	10480.000	22.56	18.26	40.82	54.00	-13.18	AVG	100	136
5	15720.000	33.04	22.19	55.23	74.00	-18.77	peak	100	232
6	15720.000	20.76	22.19	42.95	54.00	-11.05	AVG	100	232

1-Emission level (dBuV/m) = Raw Value (dBuV) + Correction Factor (dB/m).

2-Correction Factor (dB/m) = Antenna Factor (dB/m) + Cable Factor (dB).

3-The other emission levels were very low against the limit.

4-Margin value = Emission level – Limit value.

5- " \* ": Fundamental frequency.

Test Channel	TX Channel 149	Detector Function	Peak (PK) Average (AV)
Frequency Range	1GHz ~ 40GHz		

Antennal Polarity & Test Distance: Horizontal at 3 m									
No.	Frequency (MHz)	Reading (dBuV)	Factor (dB)	Emission Level (dBuV/m)	Limit (dBuV/m)	Margin (dB)	Detector	Antenna Height (cm)	Table Angle (Degree)
1#	5725.000	47.41	6.96	54.37	122.20	-67.83	peak	100	87
2*	5745.000	103.14	6.99	110.13			peak	100	87
3 *	5745.000	86.75	6.99	93.74			AVG	100	87
4	11490.000	32.40	19.77	52.17	74.00	-21.83	peak	138	220
5	11490.000	20.35	19.77	40.12	54.00	-13.88	AVG	138	220
6	17235.000	33.39	26.17	59.56	68.30	-8.74	peak	114	199
7	17235.000	20.88	26.17	47.05	54.00	-6.95	AVG	114	199
Antennal Polarity & Test Distance: Vertical at 3 m									
No.	Frequency (MHz)	Reading (dBuV)	Factor (dB)	Emission Level (dBuV/m)	Limit (dBuV/m)	Margin (dB)	Detector	Antenna Height (cm)	Table Angle (Degree)
1#	5725.000	42.17	6.96	49.13	122.20	-73.07	peak	243	187
2*	5745.000	93.87	6.99	100.86			peak	243	187
3 *	5745.000	76.88	6.99	83.87			AVG	243	187
4	11490.000	34.15	19.77	53.92	74.00	-20.08	peak	162	275
5	11490.000	20.35	19.77	40.12	54.00	-13.88	AVG	162	275
6	17235.000	36.21	26.17	62.38	68.30	-5.92	peak	130	207
7	17235.000	20.83	26.17	47.00	54.00	-7.00	AVG	130	207

1-Emission level (dBuV/m) = Raw Value (dBuV) + Correction Factor (dB/m).

2-Correction Factor (dB/m) = Antenna Factor (dB/m) + Cable Factor (dB).

3-The other emission levels were very low against the limit.

4-Margin value = Emission level – Limit value.

5- " \* ": Fundamental frequency.

6- " # ": The radiated frequency is out of the restricted band

Test Channel	TX Channel 157	Detector Function	Peak (PK) Average (AV)
Frequency Range	1GHz ~ 40GHz		

Antennal Polarity & Test Distance: Horizontal at 3 m									
No.	Frequency (MHz)	Reading (dBuV)	Factor (dB)	Emission Level (dBuV/m)	Limit (dBuV/m)	Margin (dB)	Detector	Antenna Height (cm)	Table Angle (Degree)
1 #	5725.000	35.23	6.96	42.19	122.20	-80.01	peak	100	101
2 *	5785.000	102.55	7.07	109.62			peak	100	101
3 *	5785.000	86.00	7.07	93.07			AVG	100	101
4	5850.000	34.06	7.20	41.26	122.20	-80.94	peak	100	101
5	11570.000	34.97	19.75	54.72	74.00	-19.28	peak	152	226
6	11570.000	20.08	19.75	39.83	54.00	-14.17	AVG	152	226
7	17355.000	35.41	26.68	62.09	68.30	-6.21	peak	127	132
8	17355.000	20.27	26.68	46.95	54.00	-7.05	AVG	127	132
Antennal Polarity & Test Distance: Vertical at 3 m									
No.	Frequency (MHz)	Reading (dBuV)	Factor (dB)	Emission Level (dBuV/m)	Limit (dBuV/m)	Margin (dB)	Detector	Antenna Height (cm)	Table Angle (Degree)
1 #	5725.000	34.89	6.96	41.85	122.20	-80.35	peak	296	124
2 *	5785.000	94.47	7.07	101.54			peak	296	124
3 *	5785.000	76.59	7.07	83.66			AVG	296	124
4	5850.000	33.10	7.20	40.30	122.20	-81.90	peak	296	124
5	11570.000	35.26	19.75	55.01	74.00	-18.99	peak	100	203
6	11570.000	20.37	19.75	40.12	54.00	-13.88	AVG	100	203
7	17355.000	35.66	26.68	62.34	68.30	-5.96	peak	152	146
8	17355.000	20.34	26.68	47.02	54.00	-6.98	AVG	152	146

1-Emission level (dBuV/m) = Raw Value (dBuV) + Correction Factor (dB/m).

2-Correction Factor (dB/m) = Antenna Factor (dB/m) + Cable Factor (dB).

3-The other emission levels were very low against the limit.

4-Margin value = Emission level – Limit value.

5- " \* ": Fundamental frequency.

6- " # ": The radiated frequency is out of the restricted band

Test Channel	TX Channel 165	Detector Function	Peak (PK) Average (AV)
Frequency Range	1GHz ~ 40GHz		

Antennal Polarity & Test Distance: Horizontal at 3 m									
No.	Frequency (MHz)	Reading (dBuV)	Factor (dB)	Emission Level (dBuV/m)	Limit (dBuV/m)	Margin (dB)	Detector	Antenna Height (cm)	Table Angle (Degree)
1 *	5825.000	102.49	7.15	109.64			peak	100	81
2 *	5825.000	85.28	7.15	92.43			AVG	100	81
3	5850.000	44.12	7.20	51.32	122.20	-70.88	peak	100	81
4	11650.000	34.54	19.72	54.26	74.00	-19.74	peak	138	212
5	11650.000	20.49	19.72	40.21	54.00	-13.79	AVG	138	212
6	17475.000	33.95	27.19	61.14	68.30	-7.16	peak	100	356
7	17475.000	19.92	27.19	47.11	54.00	-6.89	AVG	100	356
Antennal Polarity & Test Distance: Vertical at 3 m									
No.	Frequency (MHz)	Reading (dBuV)	Factor (dB)	Emission Level (dBuV/m)	Limit (dBuV/m)	Margin (dB)	Detector	Antenna Height (cm)	Table Angle (Degree)
1 *	5825.000	94.58	7.15	101.73			peak	336	175
2 *	5825.000	76.34	7.15	83.49			AVG	336	175
3	5850.000	42.62	7.20	49.82	122.20	-72.38	peak	336	175
4	11650.000	32.69	19.72	52.41	74.00	-21.59	peak	154	263
5	11650.000	20.39	19.72	40.11	54.00	-13.89	AVG	154	263
6	17475.000	33.68	27.19	60.87	68.30	-7.43	peak	129	201
7	17475.000	19.84	27.19	47.03	54.00	-6.97	AVG	129	201

1-Emission level (dBuV/m) = Raw Value (dBuV) + Correction Factor (dB/m).

2-Correction Factor (dB/m) = Antenna Factor (dB/m) + Cable Factor (dB).

3-The other emission levels were very low against the limit.

4-Margin value = Emission level – Limit value.

5- " \* ": Fundamental frequency.

6- " # ": The radiated frequency is out of the restricted band



**802.11n HT40**

Test Channel	TX Channel 38	Detector Function	Peak (PK) Average (AV)
Frequency Range	1GHz ~ 40GHz		

Antennal Polarity & Test Distance: Horizontal at 3 m									
No.	Frequency (MHz)	Reading (dBuV)	Factor (dB)	Emission Level (dBuV/m)	Limit (dBuV/m)	Margin (dB)	Detector	Antenna Height (cm)	Table Angle (Degree)
1	5150.000	39.54	7.54	47.08	74.00	-26.92	peak	100	323
2	5150.000	27.53	7.54	35.07	54.00	-18.93	AVG	100	323
3 *	5190.000	95.31	8.80	104.11			peak	100	323
4 *	5190.000	75.58	8.80	84.38			AVG	100	323
5	10380.000	32.42	17.93	50.35	68.30	-17.95	peak	124	279
6	10380.000	25.88	17.93	43.81	54.00	-10.19	AVG	124	279
7	15570.000	35.11	22.24	57.35	74.00	-16.65	peak	100	174
8	15570.000	21.94	22.24	44.18	54.00	-9.82	AVG	100	174
Antennal Polarity & Test Distance: Vertical at 3 m									
No.	Frequency (MHz)	Reading (dBuV)	Factor (dB)	Emission Level (dBuV/m)	Limit (dBuV/m)	Margin (dB)	Detector	Antenna Height (cm)	Table Angle (Degree)
1	5150.000	35.71	7.54	43.25	74.00	-30.75	peak	332	140
2	5150.000	23.53	7.54	31.07	54.00	-22.93	AVG	332	140
3 *	5190.000	89.93	8.80	98.73			peak	332	140
4 *	5190.000	70.46	8.80	79.26			AVG	332	140
5	10380.000	33.49	17.93	51.42	68.30	-16.88	peak	158	182
6	10380.000	20.37	17.93	38.30	54.00	-15.70	AVG	158	182
7	15570.000	35.75	22.24	57.99	74.00	-16.01	peak	136	122
8	15570.000	21.91	22.24	44.15	54.00	-9.85	AVG	136	122

1-Emission level (dBuV/m) = Raw Value (dBuV) + Correction Factor (dB/m).

2-Correction Factor (dB/m) = Antenna Factor (dB/m) + Cable Factor (dB).

3-The other emission levels were very low against the limit.

4-Margin value = Emission level – Limit value.

5- " \* ": Fundamental frequency.

Test Channel	TX Channel 46	Detector Function	Peak (PK) Average (AV)
Frequency Range	1GHz ~ 40GHz		

Antennal Polarity & Test Distance: Horizontal at 3 m									
No.	Frequency (MHz)	Reading (dBuV)	Factor (dB)	Emission Level (dBuV/m)	Limit (dBuV/m)	Margin (dB)	Detector	Antenna Height (cm)	Table Angle (Degree)
1	5150.000	36.79	7.54	44.33	74.00	-29.67	peak	100	319
2	5150.000	24.39	7.54	31.93	54.00	-22.07	AVG	100	319
3 *	5230.000	95.60	8.26	103.86			peak	100	319
4 *	5230.000	75.84	8.26	84.10			AVG	100	319
5	10460.000	33.45	18.19	51.64	68.30	-16.66	peak	100	268
6	10460.000	21.63	18.19	39.82	54.00	-14.18	AVG	100	268
7	15690.000	33.92	22.20	56.12	74.00	-17.88	peak	117	203
8	15690.000	20.91	22.20	43.11	54.00	-10.89	AVG	117	203
Antennal Polarity & Test Distance: Vertical at 3 m									
No.	Frequency (MHz)	Reading (dBuV)	Factor (dB)	Emission Level (dBuV/m)	Limit (dBuV/m)	Margin (dB)	Detector	Antenna Height (cm)	Table Angle (Degree)
1	5150.000	37.71	7.54	45.25	74.00	-28.75	peak	327	115
2	5150.000	24.35	7.54	31.89	54.00	-22.11	AVG	327	115
3 *	5230.000	89.95	8.26	98.21			peak	327	115
4 *	5230.000	70.62	8.26	78.88			AVG	327	115
5	10460.000	32.05	18.19	50.24	68.30	-18.06	peak	151	203
6	10460.000	23.05	18.19	41.24	54.00	-12.76	AVG	151	203
7	15690.000	33.58	22.20	55.78	74.00	-18.22	peak	142	139
8	15690.000	20.93	22.20	43.13	54.00	-10.87	AVG	142	139

1-Emission level (dBuV/m) = Raw Value (dBuV) + Correction Factor (dB/m).

2-Correction Factor (dB/m) = Antenna Factor (dB/m) + Cable Factor (dB).

3-The other emission levels were very low against the limit.

4-Margin value = Emission level – Limit value.

5- " \* ": Fundamental frequency.

Test Channel	TX Channel 151	Detector Function	Peak (PK) Average (AV)
Frequency Range	1GHz ~ 40GHz		

**Antennal Polarity & Test Distance: Horizontal at 3 m**

No.	Frequency (MHz)	Reading (dBuV)	Factor (dB)	Emission Level (dBuV/m)	Limit (dBuV/m)	Margin (dB)	Detector	Antenna Height (cm)	Table Angle (Degree)
1 #	5725.000	51.14	6.96	58.10	122.20	-64.10	peak	100	94
2 *	5755.000	99.82	7.01	106.83			peak	100	94
3 *	5755.000	76.01	7.01	83.02			AVG	100	94
4	11510.000	32.13	19.78	51.91	74.00	-22.09	peak	144	185
5	11510.000	20.05	19.78	39.83	54.00	-14.17	AVG	144	185
6	17265.000	34.49	26.30	60.79	68.30	-7.51	peak	126	203
7	17265.000	20.88	26.30	47.18	54.00	-6.82	AVG	126	203

**Antennal Polarity & Test Distance: Vertical at 3 m**

No.	Frequency (MHz)	Reading (dBuV)	Factor (dB)	Emission Level (dBuV/m)	Limit (dBuV/m)	Margin (dB)	Detector	Antenna Height (cm)	Table Angle (Degree)
1 #	5725.000	38.29	6.96	45.25	122.20	-76.95	peak	261	286
2 *	5755.000	90.52	7.01	97.53			peak	261	286
3 *	5755.000	71.47	7.01	78.48			AVG	261	286
4	11510.000	32.38	19.78	52.16	74.00	-21.84	peak	156	244
5	11510.000	20.18	19.78	39.96	54.00	-14.04	AVG	156	244
6	17265.000	34.52	26.30	60.82	68.30	-7.48	peak	108	325
7	17265.000	20.83	26.30	47.13	54.00	-6.87	AVG	108	325

1-Emission level (dBuV/m) = Raw Value (dBuV) + Correction Factor (dB/m).

2-Correction Factor (dB/m) = Antenna Factor (dB/m) + Cable Factor (dB).

3-The other emission levels were very low against the limit.

4-Margin value = Emission level – Limit value.

5- " \* ": Fundamental frequency.

6- " # ": The radiated frequency is out of the restricted band

Test Channel	TX Channel 159	Detector Function	Peak (PK) Average (AV)
Frequency Range	1GHz ~ 40GHz		

Antennal Polarity & Test Distance: Horizontal at 3 m									
No.	Frequency (MHz)	Reading (dBuV)	Factor (dB)	Emission Level (dBuV/m)	Limit (dBuV/m)	Margin (dB)	Detector	Antenna Height (cm)	Table Angle (Degree)
1 *	5795.000	100.07	7.09	107.16			peak	100	88
2 *	5795.000	76.40	7.09	83.49			AVG	100	88
3	5825.000	51.19	7.15	58.34	122.20	-63.86	peak	100	88
4	11590.000	32.54	19.74	52.28	74.00	-21.72	peak	100	246
5	11590.000	20.29	19.74	40.03	54.00	-13.97	AVG	100	246
6	17385.000	34.43	26.82	61.25	68.30	-7.05	peak	163	174
7	17385.000	19.54	26.82	46.36	54.00	-7.64	AVG	163	174
Antennal Polarity & Test Distance: Vertical at 3 m									
No.	Frequency (MHz)	Reading (dBuV)	Factor (dB)	Emission Level (dBuV/m)	Limit (dBuV/m)	Margin (dB)	Detector	Antenna Height (cm)	Table Angle (Degree)
1 *	5795.000	91.52	7.09	98.61			peak	272	238
2 *	5795.000	71.83	7.09	78.92			AVG	272	238
3	5825.000	39.18	7.15	46.33	122.20	-75.87	peak	272	238
4	11590.000	33.41	19.74	53.15	74.00	-20.85	peak	144	158
5	11590.000	21.14	19.74	40.88	54.00	-13.12	AVG	144	158
6	17385.000	34.65	26.82	61.47	68.30	-6.83	peak	121	287
7	17385.000	19.43	26.82	46.25	54.00	-7.75	AVG	121	287

1-Emission level (dBuV/m) = Raw Value (dBuV) + Correction Factor (dB/m).

2-Correction Factor (dB/m) = Antenna Factor (dB/m) + Cable Factor (dB).

3-The other emission levels were very low against the limit.

4-Margin value = Emission level – Limit value.

5- " \* ": Fundamental frequency.

6- " # ": The radiated frequency is out of the restricted band

**802.11ac VHT80**

Test Channel	TX Channel 42	Detector Function	Peak (PK) Average (AV)
Frequency Range	1GHz ~ 40GHz		

Antennal Polarity & Test Distance: Horizontal at 3 m									
No.	Frequency (MHz)	Reading (dBuV)	Factor (dB)	Emission Level (dBuV/m)	Limit (dBuV/m)	Margin (dB)	Detector	Antenna Height (cm)	Table Angle (Degree)
1	5150.000	45.63	7.54	53.17	74.00	-20.83	peak	100	326
2	5150.000	30.29	7.54	37.83	54.00	-16.17	AVG	100	326
3 *	5210.000	93.04	8.84	101.88			peak	100	326
4 *	5210.000	70.02	8.84	78.86			AVG	100	326
5	10420.000	32.63	18.06	50.69	68.30	-17.61	peak	110	179
6	10420.000	26.09	18.06	44.15	54.00	-9.85	AVG	110	179
7	15630.000	33.40	22.21	55.61	74.00	-18.39	peak	168	214
8	15630.000	21.21	22.21	43.42	54.00	-10.58	AVG	168	214
Antennal Polarity & Test Distance: Vertical at 3 m									
No.	Frequency (MHz)	Reading (dBuV)	Factor (dB)	Emission Level (dBuV/m)	Limit (dBuV/m)	Margin (dB)	Detector	Antenna Height (cm)	Table Angle (Degree)
1	5150.000	42.60	7.54	50.14	74.00	-23.86	peak	354	112
2	5150.000	27.08	7.54	34.62	54.00	-19.38	AVG	354	112
3 *	5210.000	85.39	8.84	94.23			peak	354	112
4 *	5210.000	63.31	8.84	72.15			AVG	354	112
5	10420.000	32.98	18.06	51.04	68.30	-17.26	peak	160	247
6	10420.000	23.11	18.06	41.17	54.00	-12.83	AVG	160	247
7	15630.000	32.51	22.21	54.72	74.00	-19.28	peak	142	185
8	15630.000	21.07	22.21	43.28	54.00	-10.72	AVG	142	185

1-Emission level (dBuV/m) = Raw Value (dBuV) + Correction Factor (dB/m).

2-Correction Factor (dB/m) = Antenna Factor (dB/m) + Cable Factor (dB).

3-The other emission levels were very low against the limit.

4-Margin value = Emission level – Limit value.

5- " \* ": Fundamental frequency.

Test Channel	TX Channel 155	Detector Function	Peak (PK) Average (AV)
Frequency Range	1GHz ~ 40GHz		

Antennal Polarity & Test Distance: Horizontal at 3 m									
No.	Frequency (MHz)	Reading (dBuV)	Factor (dB)	Emission Level (dBuV/m)	Limit (dBuV/m)	Margin (dB)	Detector	Antenna Height (cm)	Table Angle (Degree)
1 #	5725.000	51.87	6.96	58.83	122.20	-63.37	peak	100	101
2#	5755.000	97.47	7.01	104.48			peak	100	101
3 *	5755.000	70.35	7.01	77.36			AVG	100	101
4 *	5850.000	46.87	7.20	54.07	122.20	-68.13	peak	100	101
5	11550.000	35.28	19.76	55.04	74.00	-18.96	peak	108	241
6	11550.000	20.00	19.76	39.76	54.00	-14.24	AVG	108	241
7	17325.000	35.60	26.55	62.15	68.30	-6.15	peak	155	196
9	17325.000	20.47	26.55	47.02	54.00	-6.98	AVG	155	196
Antennal Polarity & Test Distance: Vertical at 3 m									
No.	Frequency (MHz)	Reading (dBuV)	Factor (dB)	Emission Level (dBuV/m)	Limit (dBuV/m)	Margin (dB)	Detector	Antenna Height (cm)	Table Angle (Degree)
1 #	5725.000	47.33	6.96	54.29	122.20	-67.91	peak	257	261
2#	5755.000	88.25	7.01	95.26			peak	257	261
3 *	5755.000	62.30	7.01	69.31			AVG	257	261
4 *	5850.000	44.22	7.20	51.42	122.20	-70.78	peak	257	261
5	11550.000	35.61	19.76	55.37	74.00	-18.63	peak	142	213
6	11550.000	20.06	19.76	39.82	54.00	-14.18	AVG	142	213
7	17325.000	35.99	26.55	62.54	68.30	-5.76	peak	111	178
8	17325.000	20.55	26.55	47.10	54.00	-6.90	AVG	111	178

1-Emission level (dBuV/m) = Raw Value (dBuV) + Correction Factor (dB/m).

2-Correction Factor (dB/m) = Antenna Factor (dB/m) + Cable Factor (dB).

3-The other emission levels were very low against the limit.

4-Margin value = Emission level – Limit value.

5- " \* ": Fundamental frequency.

6- " # ": The radiated frequency is out of the restricted band

### 3.2 Conducted emission measurement

#### 3.2.1 Limits of conducted emission measurement

Frequency of emission (MHz)	Conducted limit (dB $\mu$ V)	
	Quasi-peak	Average
0.15 ~ 0.5	66 to 56	56 to 46
0.5 ~ 5	56	46
5 ~ 30	60	50

- NOTE:**
1. The lower limit shall apply at the transition frequencies.
  2. The limit decreases in line with the logarithm of the frequency in the range of 0.15 to 0.50MHz.
  3. All emanations from a class A/B digital device or system, including any network of conductors and apparatus connected thereto, shall not exceed the level of field strengths specified above.

#### 3.2.2 Test instruments

Description & Manufacturer	Model No.	Serial No.	Date of Calibration	Due Date of Calibration
EMI Test Receiver Rohde&Schwarz	ESCI3	101418	2019-09-18	2020-09-17
Artificial Mains Network Rohde&Schwarz	ENV216	3560.6550.15	2019-10-18	2020-10-17
Test software FARAD	EZ_EMC V1.1.4.2	N/A	N/A	N/A
Hygrothermograph Yuhuaze	HTC-1	NA	2019-10-18	2020-10-17
Digital Multimeter FLUKE	15B+	43512617WS	2019-10-18	2020-10-17

- Note:
1. The calibration interval of the above test instruments is 12 months and the calibrations are traceable to CEPREI/CHINA.
  2. The test was performed in Shielded Room 743.

### 3.2.3 Test procedures

- The EUT was placed 0.4 meters from the conducting wall of the shielded room with EUT being connected to the power mains through a line impedance stabilization network (LISN). Other support units were connected to the power mains through another LISN. The two LISNs provide 50 ohm/ 50uH of coupling impedance for the measuring instrument.
- Both lines of the power mains connected to the EUT were checked for maximum conducted interference.
- The frequency range from 150kHz to 30MHz was searched. Emission levels under (Limit - 20dB) were not recorded.

**Note:** All modes of operation were investigated and the worst-case emissions are reported.

### 3.2.4 Deviation from test standard

No deviation.

### 3.2.5 Test setup

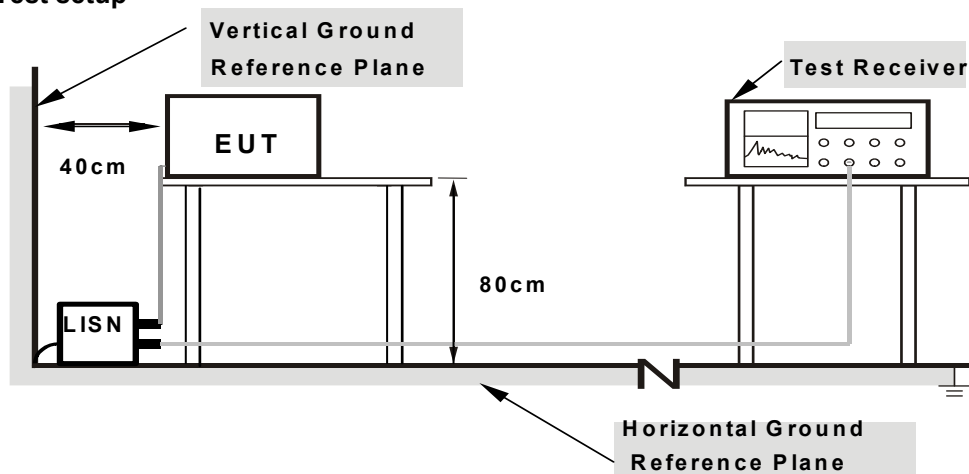

- Note:**
- Support units were connected to second LISN.
  - Both of LISNs (AMN) are 80 cm from EUT and at least 80 from other units and other metal planes

For the actual test configuration, please refer to the attached file (Test Setup Photo).

### 3.2.6 EUT operating conditions

Same as 2.4



### 3.2.7 Test results

Conducted worst-case data: 802.11a

Frequency Range	150kHz ~ 30MHz		Detector Function & Resolution band width		Quasi-Peak (QP) /Average (AV), 9kHz		
Input Power	DC12V from DC port input		Phase Of Power: Line (L)				
No	Frequency (MHz)	Reading (dBuV)	Correct Factor dB	Emission Level (dBuV)	Limit (dBuV)	Margin (dB)	Remark Detector
1	0.3075	16.20	9.61	25.81	60.04	-34.23	QP
2	0.3075	11.75	9.61	21.36	50.04	-28.68	AVG
3	0.4380	21.12	9.58	30.70	57.10	-26.40	QP
4	0.4380	15.49	9.58	25.07	47.10	-22.03	AVG
5	0.5370	10.49	9.59	20.08	56.00	-35.92	QP
6	0.5370	6.53	9.59	16.12	46.00	-29.88	AVG
7	0.6450	11.30	9.59	20.89	56.00	-35.11	QP
8	0.6450	6.50	9.59	16.09	46.00	-29.91	AVG
9	0.7530	9.69	9.59	19.28	56.00	-36.72	QP
10	0.7530	4.81	9.59	14.40	46.00	-31.60	AVG
11	1.1220	9.04	9.55	18.59	56.00	-37.41	QP
12	1.1220	4.93	9.55	14.48	46.00	-31.52	AVG

- Remarks:**
1. Q.P. and AV. are abbreviations of quasi-peak and average individually.
  2. The emission levels of other frequencies were very low against the limit.
  3. Margin value = Emission level - Limit value
  4. Correction factor = Insertion loss + Cable loss
  5. Emission Level = Correction Factor + Reading Value.

Frequency Range	150kHz ~ 30MHz	Detector Function & Resolution band width	Quasi-Peak (QP)/Average (AV), 9kHz
Input Power	DC12V from DC port input		

Phase Of Power: NEUTral (N)

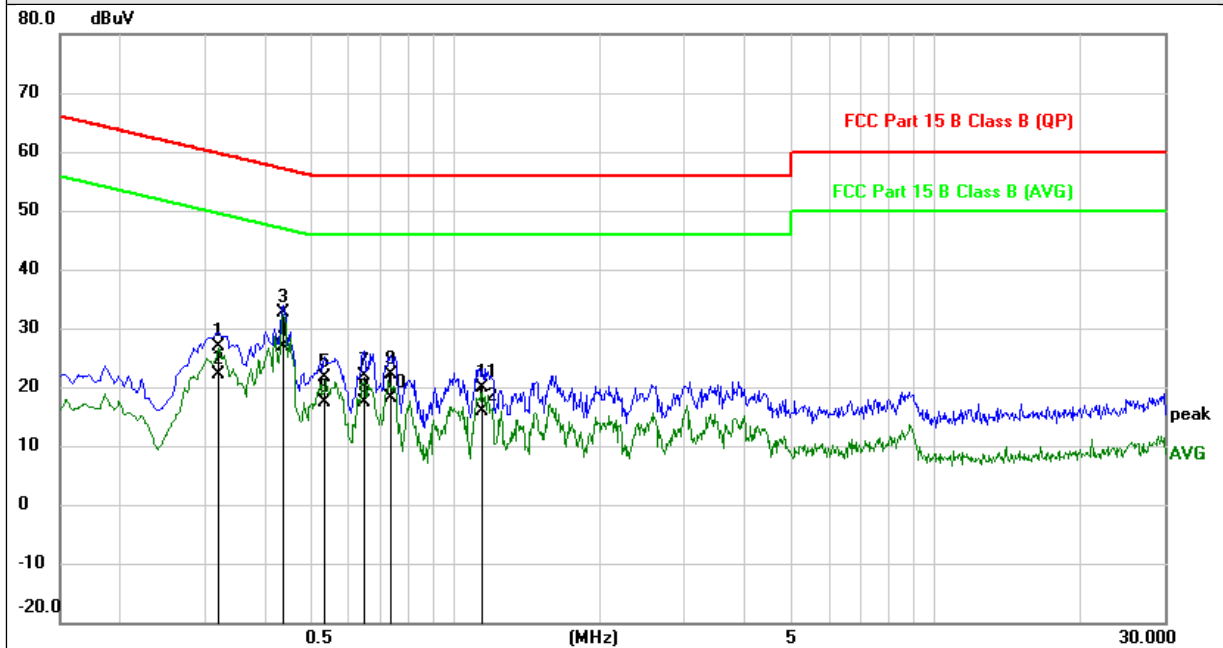

No	Frequency (MHz)	Reading (dBuV)	Correct Factor	Emission Level	Limit	Margin	Remark
			dB	(dBuV)	(dBuV)	(dB)	Detector
1	0.3209	17.28	9.61	26.89	59.68	-32.79	QP
2	0.3209	12.58	9.61	22.19	49.68	-27.49	AVG
3	0.4380	22.97	9.58	32.55	57.10	-24.55	QP
4	0.4380	17.34	9.58	26.92	47.10	-20.18	AVG
5	0.5325	12.04	9.59	21.63	56.00	-34.37	QP
6	0.5325	7.80	9.59	17.39	46.00	-28.61	AVG
7	0.6450	12.37	9.59	21.96	56.00	-34.04	QP
8	0.6450	7.70	9.59	17.29	46.00	-28.71	AVG
9	0.7350	12.65	9.59	22.24	56.00	-33.76	QP
10	0.7350	8.43	9.59	18.02	46.00	-27.98	AVG
11	1.1355	10.32	9.55	19.87	56.00	-36.13	QP
12	1.1355	6.34	9.55	15.89	46.00	-30.11	AVG

- Remarks:**
1. Q.P. and AV. are abbreviations of quasi-peak and average individually.
  2. The emission levels of other frequencies were very low against the limit.
  3. Margin value = Emission level - Limit value
  4. Correction factor = Insertion loss + Cable loss
  5. Emission Level = Correction Factor + Reading Value.

### 3.3 Transmit power measurement

#### 3.3.1 Limits of transmit power measurement

Operation Band	EUT Category		Limit
U-NII-1	-	Outdoor Access Point	1 Watt (30 dBm) (Max. e.i.r.p ≤ 125mW(21 dBm) at any elevation angle above 30 degrees as measured from the horizon)
	-	Fixed point-to-point Access Point	1 Watt (30 dBm)
	-	Indoor Access Point	1 Watt (30 dBm)
	√	Mobile and Portable client device	250mW (24 dBm)
U-NII-2A	√		250mW(24dBm) or 11 dBm+10LogB*
U-NII-2C	√		250mW(24dBm) or 11 dBm+10LogB*
U-NII-3	√		1 Watt (30 dBm)

**NOTE:** 1. Where B is the 26dB emission bandwidth in MHz.

#### 3.3.2 Test setup

For conducted power measurement setup:

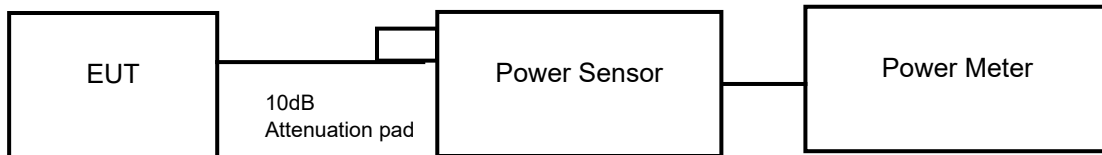

For 6/26dB bandwidth test setup

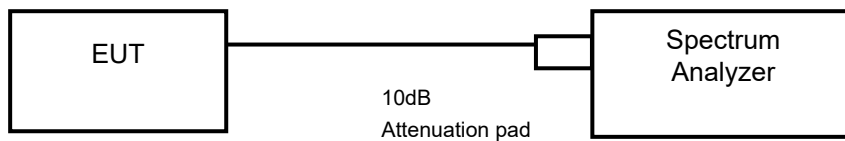

### 3.3.3 Test instruments

Description & Manufacturer	Model No.	Serial No.	Date of Calibration	Due Date of Calibration
Spectrum Keysight	N9020A	MY51240612	2019/10/18	2020/10/17
Spectrum Analyzer Rohde&Schwarz	FSV-40N	101783	2019/10/18	2020/10/17
Power Meter10Hz~18GHz Tonscend	JS0806-2	188060126	2019/10/18	2020/10/17
Signal generator Keysight	N5182A	GB40051020	2019/10/18	2020/10/17
Signal generator Keysight	N5182A	MY47420944	2019/10/18	2020/10/17
Test Software Tonscend	JS0806-2	NA	NA	NA
Hygrothermograph Yuhuaze	HTC-1	NA	2019/10/18	2020/10/17

Note: 3. The calibration interval of the above test instruments is 12 months and the calibrations are traceable to CEPREI/CHINA.

4. The test was performed in Chamber 1.

### 3.3.4 Test procedure

\*For average power measurement:

Method PM is used to perform output power measurement, trigger and gating function of wide band power meter is enabled to measure max output power of TX on burst. Duty factor is not added to measured value.

\*For 26dB bandwidth measurement:

- 1) Set RBW = approximately 1% of the emission bandwidth.
- 2) Set the VBW > RBW.
- 3) Detector = RMS.
- 4) Trace mode = max hold.
- 5) Measure the maximum width of the emission that is 26 dB down from the peak of the emission. Compare this with the RBW setting of the analyzer. Readjust RBW and repeat measurement as needed until the RBW/EBW ratio is approximately 1%.

\*For 6dB bandwidth measurement:

- 1) Set RBW = 100 kHz.
- 2) Set the video bandwidth (VBW)  $\geq$  3 RBW.
- 3) Detector = Peak.
- 4) Trace mode = max hold.
- 5) Sweep = auto couple.
- 6) Allow the trace to stabilize.
- 7) Measure the maximum width of the emission that is constrained by the frequencies associated with the two outermost amplitude points (upper and lower frequencies) that are attenuated by 6 dB relative to the maximum level measured in the fundamental emission.

### 3.3.5 Deviation from test standard

No deviation.

### 3.3.6 EUT operating conditions

The software provided by client to enable the EUT under transmission condition continuously at specific channel frequencies individually.

### 3.3.7 Test results

#### Conducted Output power:

##### 802.11a

Channel Number	Freq. (MHz)	AVG. conducted power (dBm)		AVG. conducted power (mW)		Total Max. power output		Limit (dBm)	PASS /FAIL
		Chain 0	Chain 1	Chain 0	Chain 1	mW	dBm		
36	5180	10.75	10.58	11.885	11.429	23.314	13.68	24.00	PASS
40	5200	10.52	10.42	11.272	11.015	22.287	13.48	24.00	PASS
48	5240	10.39	10.53	10.940	11.298	22.238	13.47	24.00	PASS
149	5745	11.62	12.12	14.521	16.293	30.814	14.89	30.00	PASS
157	5785	11.51	12.81	14.158	19.099	33.256	15.22	30.00	PASS
165	5825	11.04	11.89	12.706	15.453	28.158	14.50	30.00	PASS

##### 802.11ac (80MHz)

Channel Number	Freq. (MHz)	AVG. conducted power (dBm)		AVG. Conducted power (mW)		Total Max. power output		Limit (dBm)	PASS /FAIL
		Chain 0	Chain 1	Chain 0	Chain 1	mW	dBm		
42	5210	11.42	11.69	13.868	14.757	<b>28.625</b>	<b>14.57</b>	24.00	PASS
155	5775	13.59	14.38	22.856	27.416	<b>50.272</b>	<b>17.01</b>	30.00	PASS

**802.11n (20MHz)**

Channel Number	Freq. (MHz)	AVG. conducted power (dBm)		AVG. conducted power (mW)		Total Max. power output		Limit (dBm)	PASS /FAIL
		Chain 0	Chain 1	Chain 0	Chain 1	mW	dBm		
36	5180	10.71	10.99	11.776	12.560	24.336	13.86	24.00	PASS
40	5200	10.55	10.85	11.350	12.162	23.512	13.71	24.00	PASS
48	5240	10.42	10.92	11.015	12.359	23.375	13.69	24.00	PASS
149	5745	12.68	13.31	18.535	21.429	39.964	16.02	30.00	PASS
157	5785	12.51	13.12	17.824	20.512	38.335	15.84	30.00	PASS
165	5825	12.22	13.24	16.672	21.086	37.759	15.77	30.00	PASS

**802.11n (40MHz)**

Channel Number	Freq. (MHz)	AVG. conducted power (dBm)		AVG. conducted power (mW)		Total Max. power output		Limit (dBm)	PASS /FAIL
		Chain 0	Chain 1	Chain 0	Chain 1	mW	dBm		
38	5190	10.24	10.55	10.568	11.350	21.918	13.41	24.00	PASS
46	5230	10.39	10.61	10.940	11.508	22.448	13.51	24.00	PASS
151	5755	12.49	12.78	17.742	18.967	36.709	15.65	24.00	PASS
159	5795	12.31	12.90	17.022	19.498	36.520	15.63	30.00	PASS

26dB bandwidth:

802.11a

Channel Number	Freq. (MHz)	26dBc bandwidth (MHz)		PASS /FAIL
		Chain 0	Chain 1	
36	5180	19.72	19.84	PASS
40	5200	19.72	19.78	PASS
48	5240	19.68	19.92	PASS

Spectrum plot of worst value



802.11ac (80MHz)

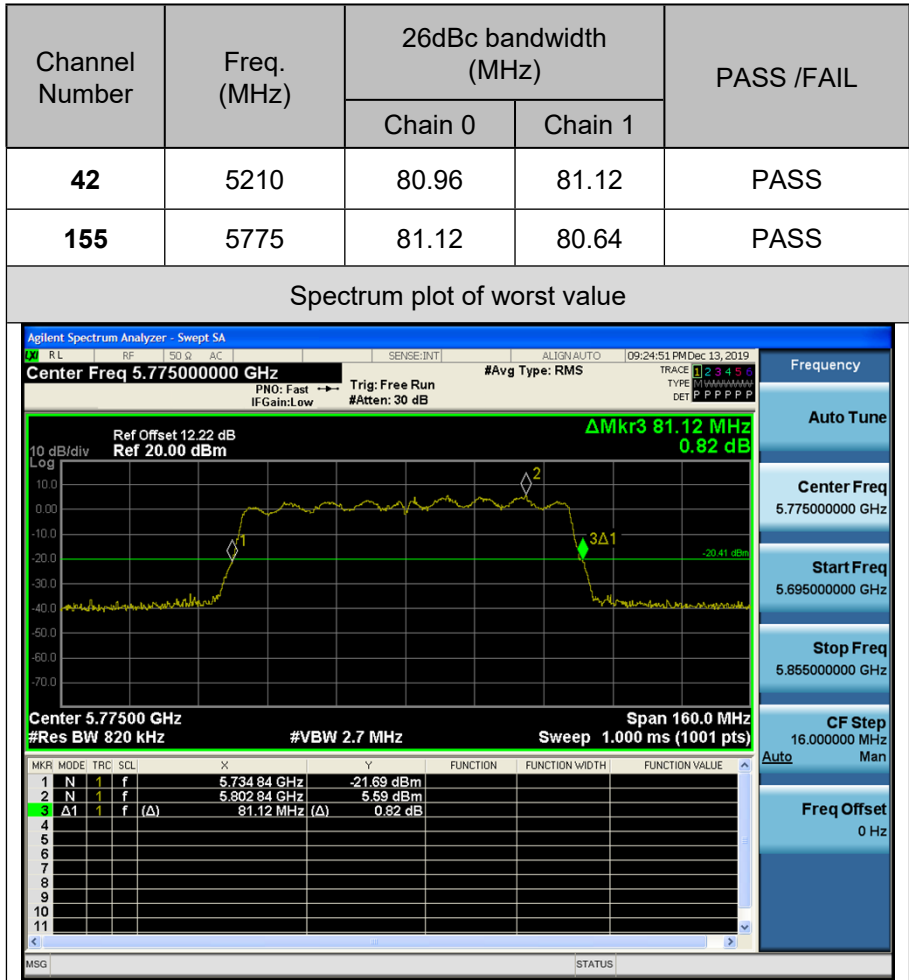



802.11n (20MHz)

Channel Number	Freq. (MHz)	26dBc bandwidth (MHz)		PASS /FAIL
		Chain 0	Chain 1	
36	5180	20.52	20.68	PASS
40	5200	20.46	20.51	PASS
48	5240	20.36	20.44	PASS

Spectrum plot of worst value



802.11n (40MHz)

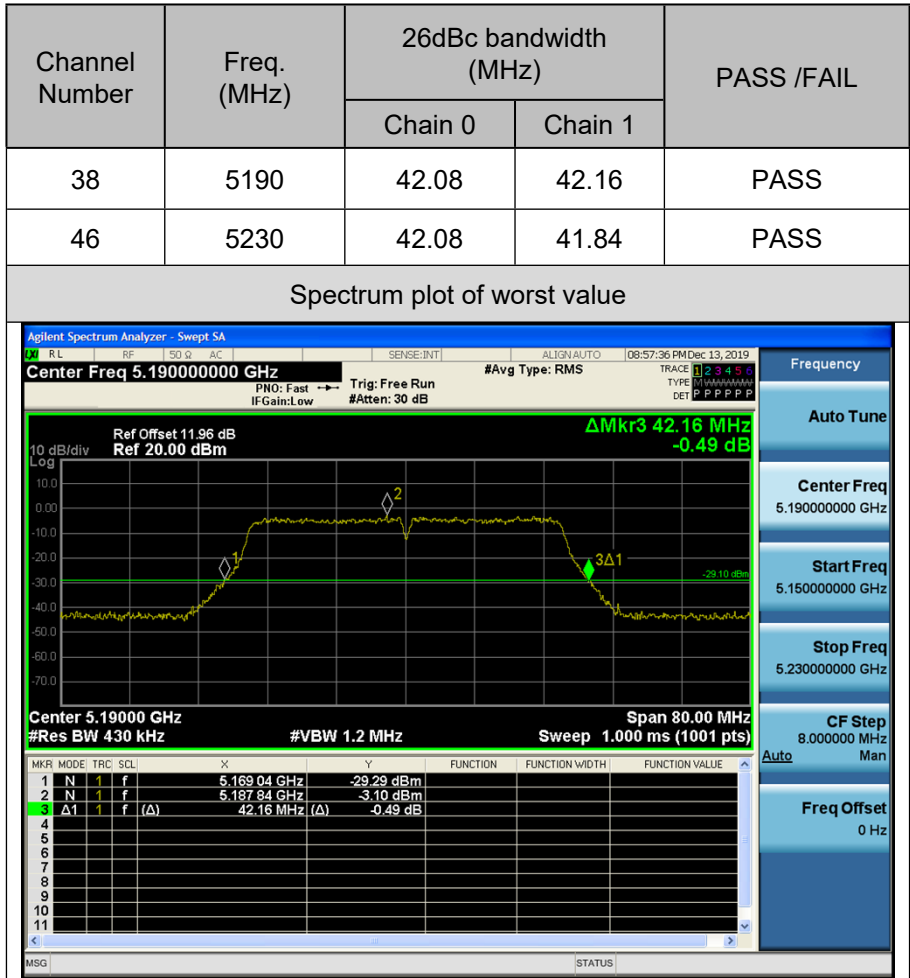

6dB bandwidth for 5725-5850MHz

802.11a



802.11n (20M)

Channel Number	Freq. (MHz)	6dBc bandwidth (MHz)		PASS /FAIL
		Chain 0	Chain 1	
149	5745	17.16	16.76	PASS
157	5785	16.96	16.64	PASS
165	5825	16.52	16.72	PASS

Spectrum plot of worst value

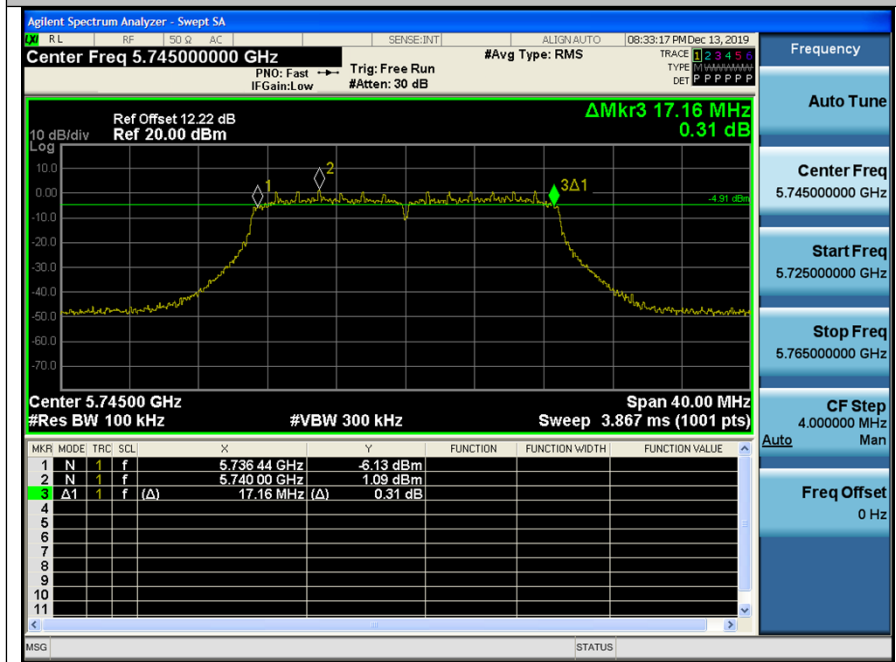

802.11n (40M)

Channel Number	Freq. (MHz)	6dBc bandwidth (MHz)		PASS /FAIL
		Chain 0	Chain 1	
151	5755	35.84	35.76	PASS
159	5795	35.68	35.84	PASS

Spectrum plot of worst value

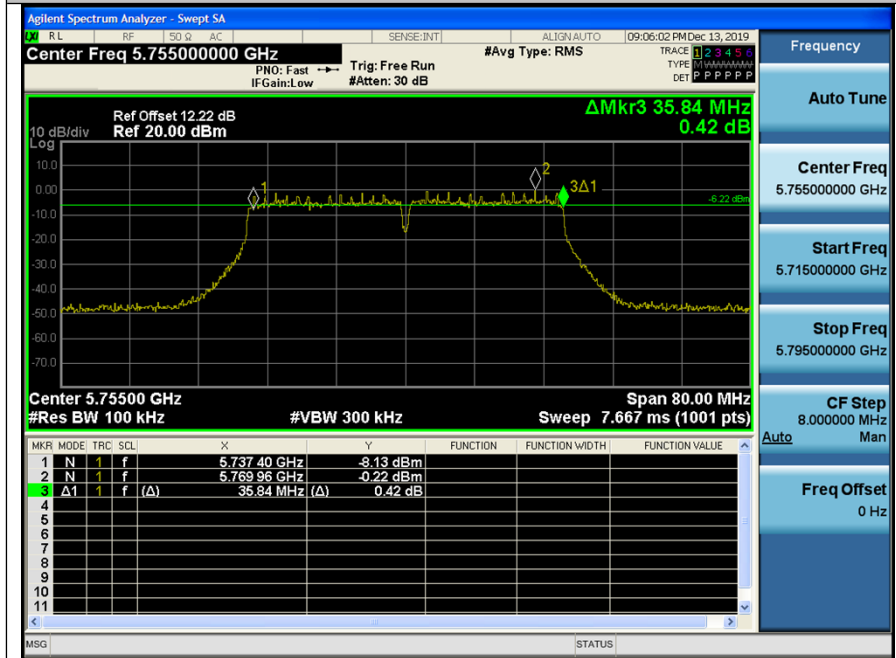

802.11ac (80MHz)

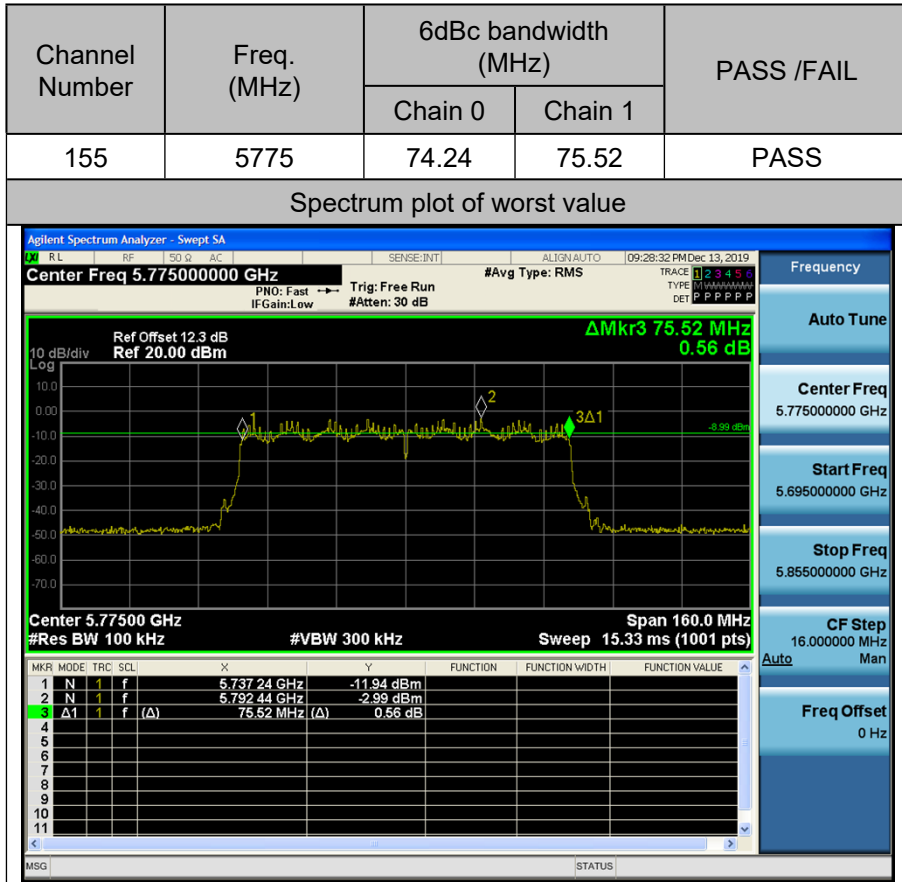

### 3.4 Peak power spectral density measurement

#### 3.4.1 Limits of peak power spectral density measurement

Operation Band	EUT Category		Limit
U-NII-1	-	Outdoor Access Point	17dBm/ MHz
	-	Fixed point-to-point Access Point	
	-	Indoor Access Point	
	√	Mobile and Portable client device	11dBm/ MHz
U-NII-2A	√		11dBm/ MHz
U-NII-2C	√		11dBm/ MHz
U-NII-3	√		30dBm/ 500kHz

#### 3.4.2 Test setup

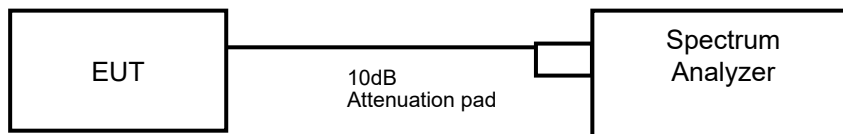

#### 3.4.3 Test instruments

Refer to section 3.3.3 to get information of above instrument.

#### 3.4.4 Test procedures

##### For U-NII-1, U-NII-2A, U-NII-2C band:

Using method SA-2

- 1) Set span to encompass the entire emission bandwidth (EBW) of the signal.
- 2) Set RBW = 1MHz, Set VBW ≥3 MHz, Detector = RMS
- 3) Set Channel power measure = 1MHz
- 4) Sweep time = auto, trigger set to "free run".
- 5) Trace average at least 100 traces in power averaging mode.
- 6) Record the max value and add 10 log (1/duty cycle)

##### For U-NII-3 band:

Using method SA-2

- 1) Set span to encompass the entire emission bandwidth (EBW) of the signal.
- 2) Set RBW = 300 kHz, Set VBW ≥1 MHz, Detector = RMS
- 3) Set Channel power measure = 1MHz
- 4) Sweep time = auto, trigger set to "free run".
- 5) Trace average at least 100 traces in power averaging mode.
- 6) Record the max value and add 10 log (1/duty cycle)

**Duty cycle factor:**

**802.11a**

Duty cycle of test signal is  $1.393/1.492=93.33\%$ ,  
 Duty cycle factor= $10*\log(1/0.9333)=0.30\text{dB}$

**802.11n HT20**

Duty cycle of test signal is  $1.305/1.430=91.25\%$ ,  
 Duty cycle factor= $10*\log(1/0.9125)=0.40\text{dB}$

**802.11n HT40**

Duty cycle of test signal is  $0.6447/0.7195=89.60\%$ ,  
 Duty cycle factor= $10*\log(1/0.8960)=0.48\text{dB}$

**802.11ac VHT80**

Duty cycle of test signal is  $0.3217/0.4053=79.37\%$ ,  
 Duty cycle factor= $10*\log(1/0.8295)=1.00\text{ dB}$

Operation mode	Duty cycle Factor(dB)	
	Chain 0	Chain 1
802.11a	0.30	
802.11n HT20	0.40	
802.11n HT40	0.48	
802.11ac VHT80	1.00	

**3.4.5 Deviation from test standard**

No deviation.

**3.4.6 EUT operating conditions**

Same as 3.3.6



### 3.4.7 Test results

#### For U-NII-1, U-NII-2A & U-NII-2C, For U-NII-3: 802.11a

Channel Number	Frequency (MHz)	RF Power Level in 1MHz BW (dBm)		Total power density (mW)		Total power density		Total power add dutycycle factor(dBm)	Limit (dBm)
		Chain 0	Chain 1	Chain 0	Chain 1	mW	dBm		
36	5180	1.539	1.714	1.425	1.484	2.909	4.638	4.938	5.99
40	5200	1.515	2.117	1.417	1.628	3.046	4.837	5.137	5.99
48	5240	2.217	2.354	1.666	1.719	3.386	5.296	5.596	5.99

Note:

1. Method 1 of power density measurement of KDB 662911 is using for calculating total power density. Total power density is summing entire spectra across ponding frequency bins on the various outputs by computer

2. For 5150~5250MHz: Directional gain = 7dBi + 10\*log(2) =10.01dBi >6dBi, so the power density limit need to reduce 4.01dB.

Channel Number	Frequency (MHz)	RF Power Level in 300kHz BW (dBm)		RF Power Level in 500kHz BW (dBm)		Total PSD (dBm/500kHz)	Total power add dutycycle factor(dBm)	Limit (dBm)
		Chain 0	Chain 1	Chain 0	Chain 1			
149	5745	5.452	4.977	3.509	3.146	6.655	6.955	25.99
157	5785	5.938	5.779	3.925	3.784	7.708	8.008	25.99
165	5825	5.823	5.819	3.822	3.819	7.641	7.941	25.99

Note:

1. Method 1 of power density measurement of KDB 662911 is using for calculating total power density. Total power density is summing entire spectra across ponding frequency bins on the various outputs by computer

2. For 5725~5850MHz: Directional gain = 7dBi + 10\*log (2) = 10.01dBi >6dBi, so the power density limit need to reduce 4.01dB.

Spectrum plot of worst value

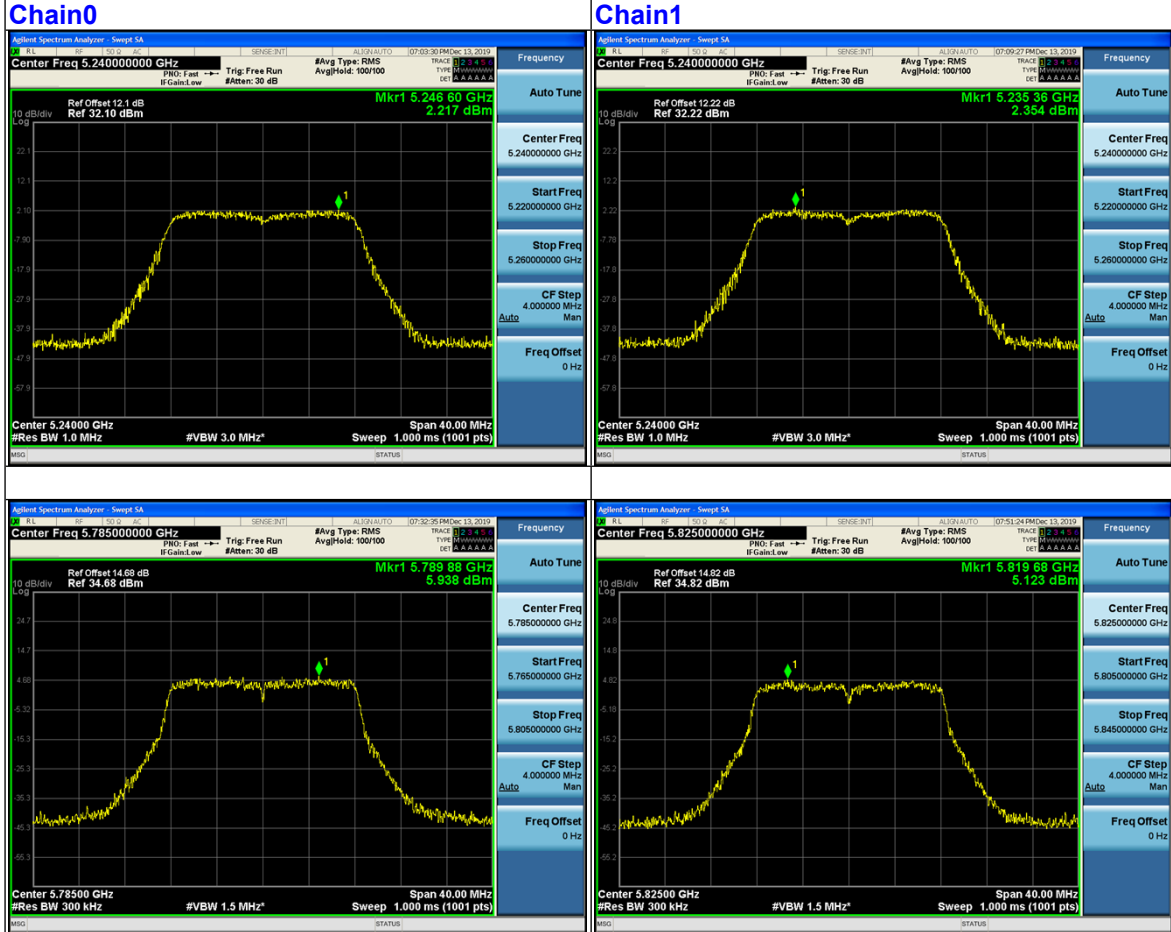

**802.11n (20MHz)**

Channel Number	Frequency (MHz)	RF Power Level in 1MHz BW (dBm)		Total power density (mW)		Total power density		Total power add dutycycle factor(dBm)	Limit (dBm)
		Chain 0	Chain 1	Chain 0	Chain 1	mW	dBm		
36	5180	2.164	2.629	1.646	1.832	3.478	5.413	5.813	5.99
40	5200	2.145	2.591	1.639	1.816	3.455	5.384	5.784	5.99
48	5240	2.198	2.972	1.659	1.982	3.641	5.613	6.013	5.99

Note:

1. Method 1 of power density measurement of KDB 662911 is using for calculating total power density. Total power density is summing entire spectra across ponding frequency bins on the various outputs by computer

2. For 5150~5250MHz: Directional gain = 7dBi + 10\*log(2) =10.01dBi >6dBi, so the power density limit need to reduce 4.01dB.

Channel Number	Frequency (MHz)	RF Power Level in 300kHz BW (dBm)		RF Power Level in 500kHz BW (dBm)		Total PSD (dBm/500kHz)	Total power add dutycycle factor(dBm)	Limit (dBm)
		Chain 0	Chain 1	Chain 0	Chain 1			
149	5745	4.935	5.264	3.115	3.360	6.476	6.876	25.99
157	5785	6.736	5.012	4.716	3.171	7.887	8.287	25.99
165	5825	6.515	5.540	4.482	3.581	8.063	8.463	25.99

Note:

1. Method 1 of power density measurement of KDB 662911 is using for calculating total power density. Total power density is summing entire spectra across ponding frequency bins on the various outputs by computer

2. For 5725~5850MHz: Directional gain = 7dBi + 10\*log(2) =10.01dBi >6dBi, so the power density limit need to reduce 4.01dB.

Spectrum plot of worst value

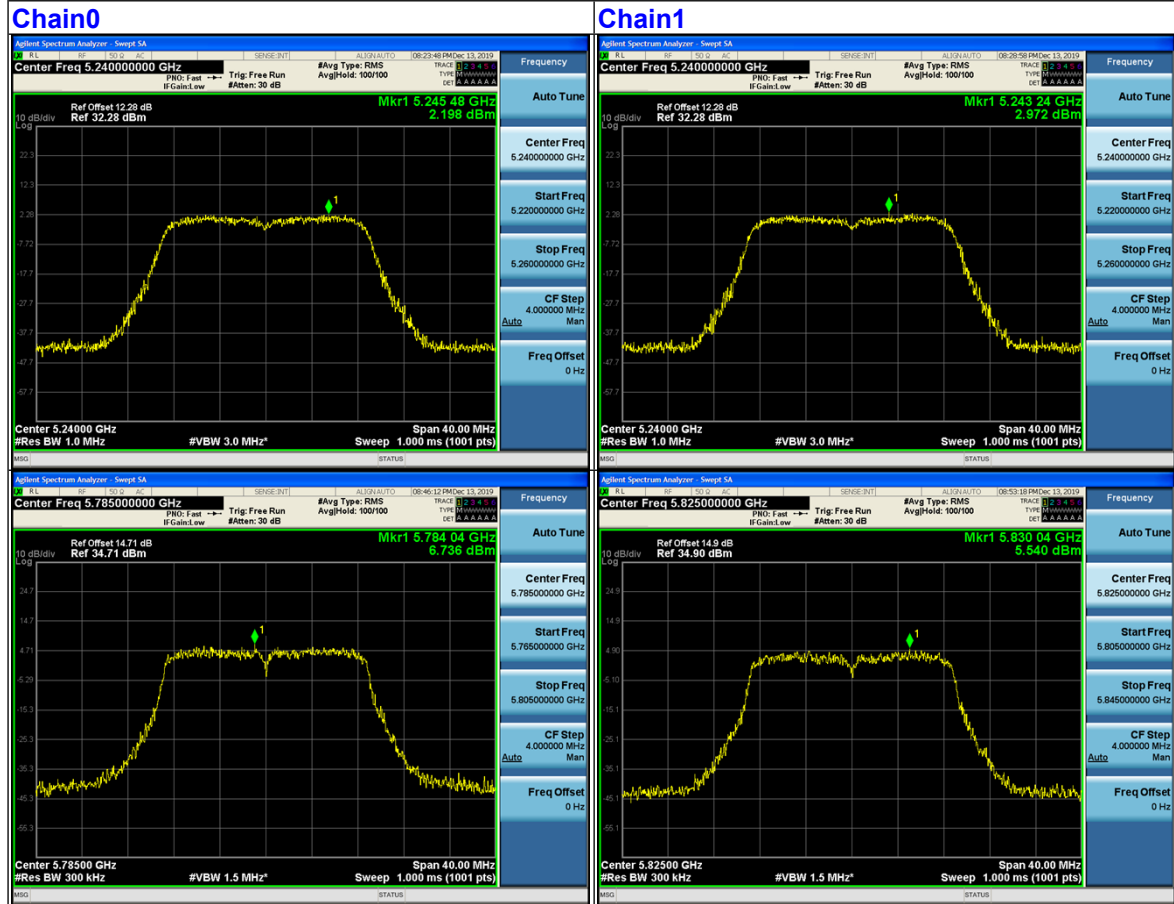

**802.11n (40MHz)**

Channel Number	Frequency (MHz)	RF Power Level in 1MHz BW (dBm)		Total power density (mW)		Total power density		Total power add dutycycle factor(dBm)	Limit (dBm)
		Chain 0	Chain 1	Chain 0	Chain 1	mW	dBm		
38	5190	0.458	-0.180	1.111	0.959	2.071	3.161	3.621	5.99
46	5230	0.006	-0.169	1.001	0.962	1.963	2.930	3.410	5399

Note:

- Method 1 of power density measurement of KDB 662911 is using for calculating total power density. Total power density is summing entire spectra across ponding frequency bins on the various outputs by computer
- For 5150~5250MHz: Directional gain= 7dBi +  $10 \cdot \log(2)$  =10.01dBi >6dBi, so the power density limit need to reduce 4.01dB.

Channel Number	Frequency (MHz)	RF Power Level in 300kHz BW (dBm)		RF Power Level in 500kHz BW (dBm)		Total PSD (dBm /500kHz)	Total power add dutycycle factor(dBm)	Limit (dBm)
		Chain 0	Chain 1	Chain 0	Chain 1			
151	5755	3.389	2.564	2.182	1.805	3.987	4.467	25.99
159	5795	4.528	3.064	2.837	2.025	4.861	5.321	25.99

Note:

- Method 1 of power density measurement of KDB 662911 is using for calculating total power density. Total power density is summing entire spectra across ponding frequency bins on the various outputs by computer
- For 5725~5850MHz: Directional gain= 7dBi +  $10 \cdot \log(2)$  =10.01dBi >6dBi, so the power density limit need to reduce 4.01dB.

Spectrum plot of worst value

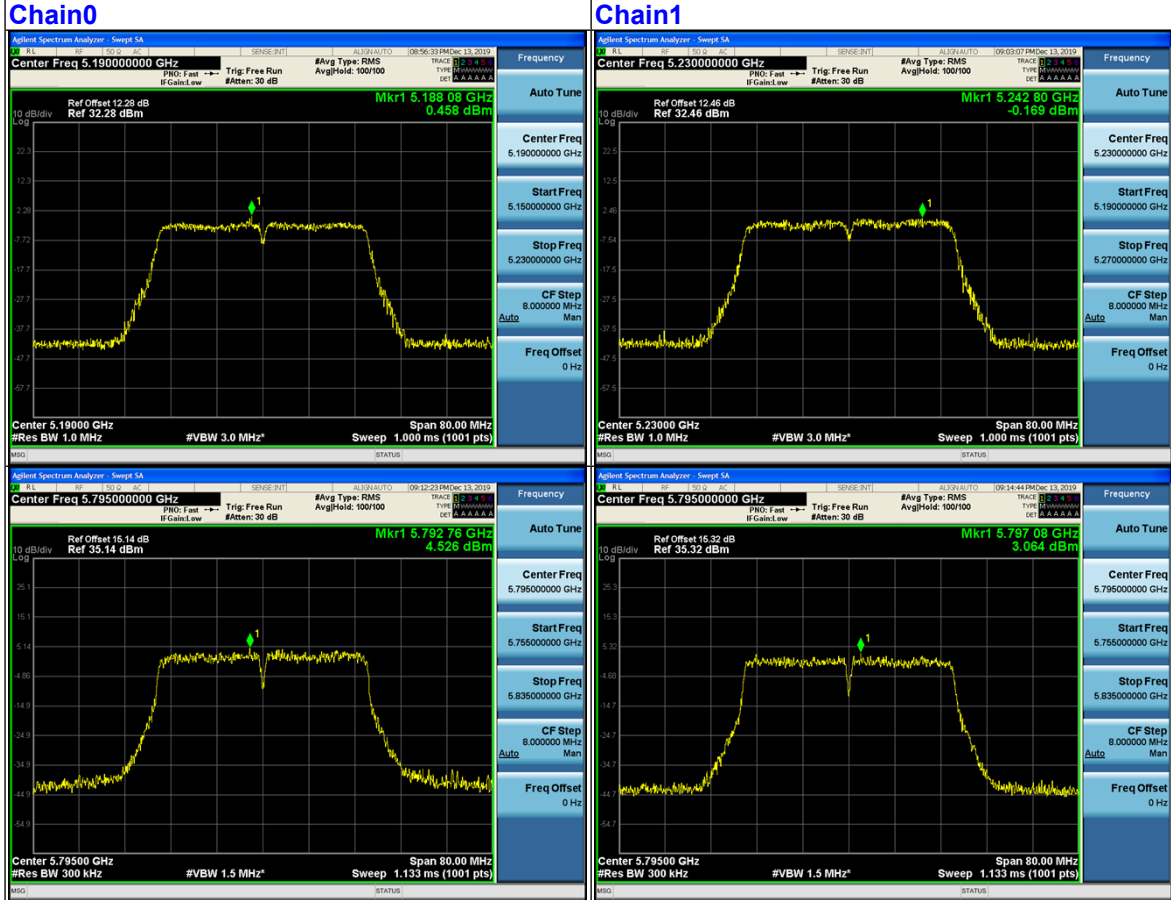

**802.11ac (80MHz)**

Channel Number	Frequency (MHz)	RF Power Level in 1MHz BW (dBm)		Total power density (mW)		Total power density		Total power add dutycycle factor(dBm)	Limit (dBm)
		Chain 0	Chain 1	Chain 0	Chain 1	mW	dBm		
42	5210	-1.992	-2.101	0.632	0.616	1.249	0.964	1.964	5.99

Note:

1. Method 1 of power density measurement of KDB 662911 is using for calculating total power density. Total power density is summing entire spectra across ponding frequency bins on the various outputs by computer

2. For 5150~5250MHz: Directional gain == 7dBi + 10\*log(2) =10.01dBi >6dBi, so the power density limit need to reduce 4.01dB.

Channel Number	Frequency (MHz)	RF Power Level in 300kHz BW (dBm)		RF Power Level in 500kHz BW (dBm)		Total PSD (dBm /500kHz)	Total power add dutycycle factor(dBm)	Limit (dBm)
		Chain 0	Chain 1	Chain 0	Chain 1			
155	5775	2.649	0.372	1.840	1.089	2.930	3.930	25.99

Note:

1. Method 1 of power density measurement of KDB 662911 is using for calculating total power density. Total power density is summing entire spectra across ponding frequency bins on the various outputs by computer

2. For 5725~5850MHz: Directional gain == 7dBi + 10\*log(2) =10.01dBi >6dBi, so the power density limit need to reduce 4.01dB.

Spectrum plot of worst value

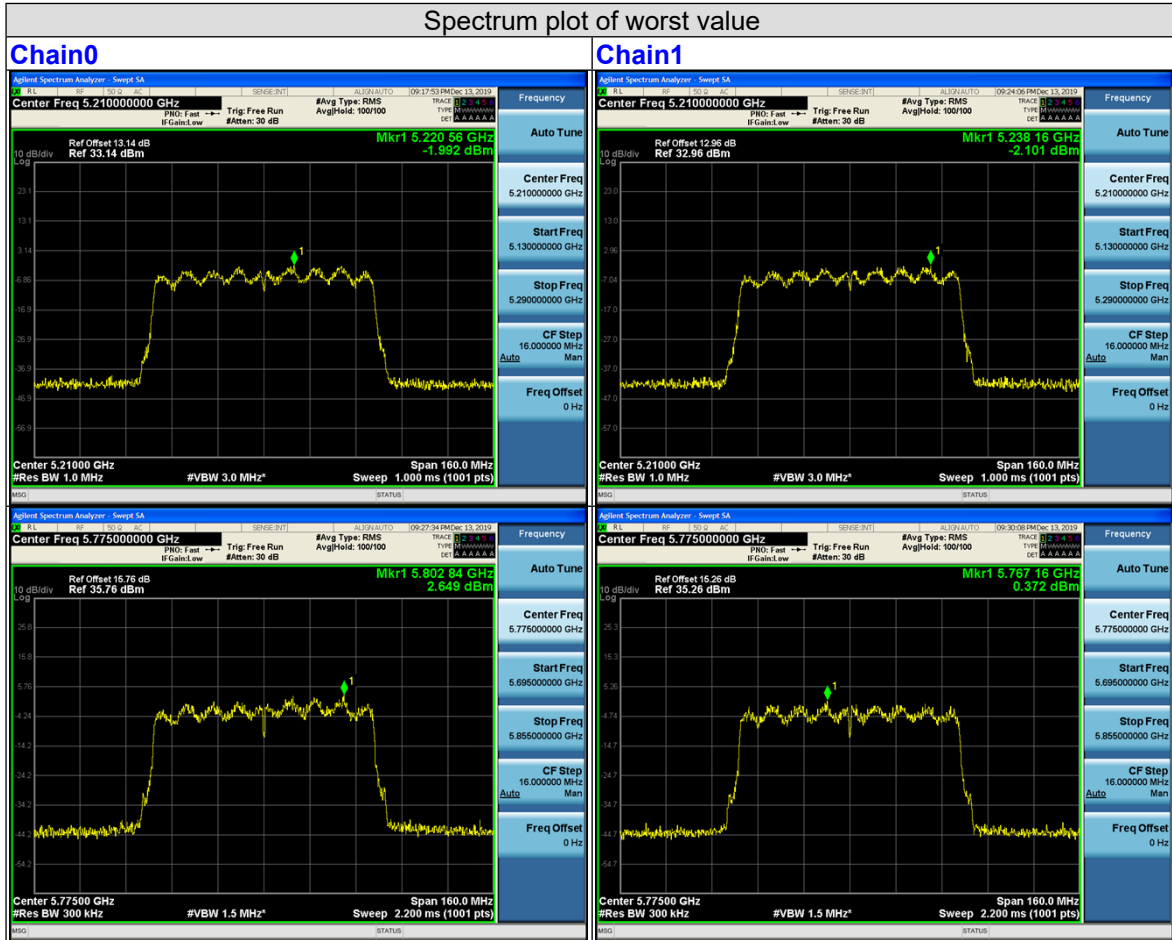



### 3.5 Frequency stability

#### 3.5.1 Limits of frequency stability measurement

The frequency of the carrier signal shall be maintained within band of operation.

#### 3.5.2 Test setup

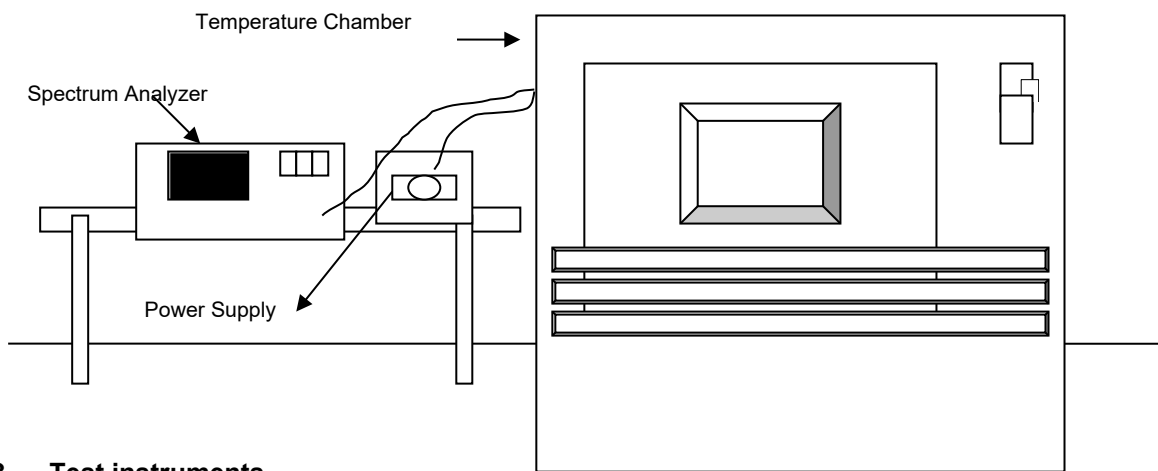

#### 3.5.3 Test instruments

Refer to section 3.3.3 to get information of above instrument.

#### **3.5.4 Test procedure**

- a. The EUT was placed inside the environmental test chamber and powered by nominal AC voltage.
- b. Turn the EUT on and couple its output to a spectrum analyzer.
- c. Turn the EUT off and set the chamber to the highest temperature specified.
- d. Allow sufficient time (approximately 30 min) for the temperature of the chamber to stabilize, turn the EUT on and measure the operating frequency after 2, 5, and 10 minutes.
- e. Repeat step 2 and 3 with the temperature chamber set to the lowest temperature.
- f. The test chamber was allowed to stabilize at +20 degree C for a minimum of 30 minutes. The supply voltage was then adjusted on the EUT from 85% to 115% and the frequency record.

#### **3.5.5 Deviation from test standard**

No deviation.

#### **3.5.6 EUT operating condition**

Set the EUT transmit at un-modulation mode to test frequency stability.

**3.5.7 Test results**

Frequency stability versus temp.									
Operating frequency: 5180MHz									
Temp. (°C)	Power supply (Vdc)	0 minute		2 minute		5 minute		10 minute	
		Measured Frequency (MHz)	Frequency Drift	Measured Frequency (MHz)	Frequency Drift	Measured Frequency (MHz)	Frequency Drift	Measured Frequency (MHz)	Frequency Drift
50	12	5179.9789	-0.00041	5179.9818	-0.00035	5179.9786	-0.00041	5179.9815	-0.00036
40	12	5179.9856	-0.00028	5179.9886	-0.00022	5179.9873	-0.00025	5179.9901	-0.00019
30	12	5180.0048	0.00009	5180.0028	0.00005	5180.0044	0.00008	5180.0047	0.00009
20	12	5179.9898	-0.00020	5179.9947	-0.00010	5179.9925	-0.00014	5179.9915	-0.00016
10	12	5179.9898	-0.00020	5179.9899	-0.00019	5179.9873	-0.00025	5179.9916	-0.00016
0	12	5180.0095	0.00018	5180.0129	0.00025	5180.0114	0.00022	5180.0111	0.00021
-10	12	5179.9775	-0.00043	5179.9766	-0.00045	5179.9762	-0.00046	5179.9791	-0.00040
-20	12	5180.0206	0.00040	5180.0216	0.00042	5180.0221	0.00043	5180.0189	0.00036
-30	12	5180.0186	0.00036	5180.0207	0.00040	5180.0222	0.00043	5180.0202	0.00039

Frequency stability versus temp.									
Operating frequency: 5180MHz									
Temp. (°C)	Power supply (Vdc)	0 minute		2 minute		5 minute		10 minute	
		Measured Frequency (MHz)	Frequency Drift	Measured Frequency (MHz)	Frequency Drift	Measured Frequency (MHz)	Frequency Drift	Measured Frequency (MHz)	Frequency Drift
20	13.2	5179.9895	-0.00020	5179.9941	-0.00011	5179.9923	-0.00015	5179.9909	-0.00018
	12	5179.9898	-0.00020	5179.9947	-0.00010	5179.9925	-0.00014	5179.9915	-0.00016
	10.8	5179.9905	-0.00018	5179.9944	-0.00011	5179.9921	-0.00015	5179.9915	-0.00016

Band 1:5150-5250MHz  
99% Occupied Bandwidth Without over DFS Band





Test Report No.: HP191107DC010-FRL

#### 4. Photographs of the test configuration

Please refer to the attached file (Test Setup Photo).

**5. Appendix a – modifications recorders for engineering changes**

No modifications were made to the EUT by the lab during the test.

## 6. Appendix b – Information on the Testing Laboratories

We, [Hwa-Hsing \(Dongguan\) Co., Ltd.](#), A global provider of TESTING and CERTIFICATION services for consumer products, electronic products and wireless information technology products. Adhering to the core values “HONEST and TRUSTWORTHY, OBJECTIVE and IMPARTIALITY, RIGOROUS and AFFICIENT”, commitment to provide professional, perfect and efficient comprehensive ONE-STOP solution of TESTING and CERTIFICATION services for Manufacturers, Buyers, Traders, Brands, Retailers. Assist client to better manage risk, protect their brands, reduce costs and cut time to over 150 markets in global. Our laboratories are FCC recognized accredited test firms and accredited and approved according to ISO/IEC 17025.

If you have any comments, please feel free to contact us at the following:

Lab Address: [No.101, Bld N1, Yuyuan 2Rd, Yuyuan Industrial Park, HuangJiang Town, Dongguan, China](#)

Contact Tel: [0769-83078199](tel:0769-83078199)

Email: [customerservice.dg@hwa-hsing.com](mailto:customerservice.dg@hwa-hsing.com)

Web Site: [www.hwa-hsing.com](http://www.hwa-hsing.com)

---END---