

FCC 47 CFR PART 15 SUBPART B
CERTIFICATION TEST REPORT

Product name: Interactive Touch Screen, LED Interactive Multi-Touch Display, Optimus-Touch Screen, Genee Touch, Interactive Led Monitor, Touch Pro

MODEL No.: TT-5515E, TT-5515EX, QIT 1255 10IN, 55G-Touch Slim-STND, P-55D, TWB-I55, TWB-I55X, TWB-I55A, TWB-I55AX, TWB-IC55, TWB-IC55X, TWB-IC55A, TWB-IC55AX, HD-I5XXXE, HD-IXXXE, WS-Z5XXX, WB-XXXXX (X can be any number of "0-9" or any letter of "A-Z")

FCC ID: 2ACYT-AHH15V69-55

REPORT NO: ES151110036E

ISSUE DATE: March 30, 2016

Prepared for

**SHENZHEN Hitevision Technology Co., Ltd.
No. 8, Qinglan 1st Road, Pingshan, Shenzhen,
Guangdong 518118, P. R. China**

Prepared by

EMTEK (SHENZHEN) CO., LTD.

**Bldg 69, Majialong Industry Zone, Nanshan District, Shenzhen,
Guangdong, China
TEL: 86-755-26954280
FAX: 86-755-26954282**

TABLE OF CONTENT

Test Report Description	Page
1. SUMMARY OF TEST RESULT	5
2. GENERAL INFORMATION	6
2.1. DESCRIPTION OF DEVICE (EUT).....	6
2.2. DESCRIPTION OF TEST FACILITY	6
2.3. DESCRIPTION OF SUPPORT DEVICE	7
2.4. MEASUREMENT UNCERTAINTY	7
3. MEASURING DEVICE AND TEST EQUIPMENT	8
3.1. FOR POWER LINE CONDUCTED EMISSION MEASUREMENT	8
3.2. FOR RADIATED EMISSION MEASUREMENT (3M CHAMBER).....	8
4. CONDUCTED EMISSION MEASUREMENT	9
4.1. BLOCK DIAGRAM OF TEST SETUP	9
4.2. MEASURING STANDARD	9
4.3. POWER LINE CONDUCTED EMISSION LIMITS (CLASS B).....	9
4.4. EUT CONFIGURATION ON MEASUREMENT	9
4.5. OPERATING CONDITION OF EUT	9
4.6. TEST PROCEDURE	10
4.7. MEASURING RESULTS	10
5. RADIATED EMISSION MEASUREMENT	21
5.1. BLOCK DIAGRAM OF TEST SETUP	21
5.2. MEASURING STANDARD	22
5.3. RADIATED EMISSION LIMITS (CLASS B).....	22
5.4. EUT CONFIGURATION ON MEASUREMENT	22
5.5. OPERATING CONDITION OF EUT	22
5.6. TEST PROCEDURE	22
5.7. MEASURING RESULTS	23
6. PHOTOGRAPHS	42
6.1. PHOTOS OF CONDUCTED EMISSION MEASUREMENT	42
6.2. PHOTOS OF RADIATION EMISSION MEASUREMENT	43

APPENDIX (Photos of EUT) (7 Pages)

TEST REPORT DESCRIPTION

Applicant : SHENZHEN Hitevision Technology Co., Ltd.

Manufacturer : SHENZHEN Hitevision Technology Co., Ltd.

Trademark : 

EUT : Interactive Touch Screen, LED Interactive Multi-Touch Display, Optimus-Touch Screen, Genee Touch, Interactive Led Monitor, Touch Pro

Model No. : TT-5515E, TT-5515EX, QIT 1255 10IN, 55G-Touch
Slim-STND, P-55D, TWB-I55, TWB-I55X, TWB-I55A, TWB-I55AX,
TWB-IC55, TWB-IC55X, TWB-IC55A, TWB-IC55AX, HD-I5XXXE,
HD-IXXXXE, WS-Z5XXX, WB-XXXXX (X can be any number of "0-9" or any letter of "A-Z")

Power Supply : AC 100-240V 50/60Hz 0.2A Max

Measurement Procedure Used:

FCC Rules and Regulations Part 15: 2015 Subpart B Class B & FCC / ANSI C63.4-2014

The device described above is tested by EMTEK (SHENZHEN) CO., LTD. to determine the maximum emission levels emanating from the device and the severe levels of the device can endure and its performance criterion. The measurement results are contained in this test report and EMTEK (SHENZHEN) CO., LTD. is assumed full of responsibility for the accuracy and completeness of these measurements. Also, this report shows that the EUT (Equipment Under Test) is technically compliant with the FCC requirements.

This report applies to above tested sample only and shall not be reproduced in part without written approval of EMTEK (SHENZHEN) CO., LTD.

Date of Test : November 11, 2015 to December 21, 2015

Prepared by : 
Yaping Shen/Editor

Reviewer : 
Joe Xia/Supervisor

Approved & Authorized Signer : 
Lisa Wang/Manager

Modified Information

Version	Report No.	Revision Date	Summary
Ver.1.0	ES151110036E	/	Original Report

1. SUMMARY OF TEST RESULT

EMISSION		
Description of Test Item	Standard & Limits	Results
Conducted Disturbance at Mains Terminals	FCC Part 15, Subpart B, Class B ANSI C63.4: 2014	Pass
Radiated Disturbance	FCC Part 15, Subpart B, Class B ANSI C63.4: 2014	Pass
Note: N/A is an abbreviation for Not Applicable.		

2. GENERAL INFORMATION

2.1. Description of Device (EUT)

EUT	:	Interactive Touch Screen, LED Interactive Multi-Touch Display, Optimus-Touch Screen, Genee Touch, Interactive Led Monitor, Touch Pro
Model Number	:	TT-5515E, TT-5515EX, QIT 1255 10IN, 55G-Touch Slim-STND, P-55D, TWB-I55, TWB-I55X, TWB-I55A, TWB-I55AX, TWB-IC55, TWB-IC55X, TWB-IC55A, TWB-IC55AX, HD-I5XXXE, HD-IXXXE, WS-Z5XXX, WB-XXXXX (X can be any number of "0-9" or any letter of "A-Z") (Note: These models are identical in circuitry and electrical, mechanical and physical construction; the only difference are appearance, trade mark and the model number. for trading purpose. We prepare TT-5515E for all test.)
Test Voltage	:	AC 120V/60Hz
Applicant	:	SHENZHEN Hitevision Technology Co., Ltd.
Address	:	No. 8, Qinglan 1st Road, Pingshan, Shenzhen, Guangdong 518118, P. R. China
Manufacturer	:	SHENZHEN Hitevision Technology Co., Ltd.
Address	:	No. 8, Qinglan 1st Road, Pingshan, Shenzhen, Guangdong 518118, P. R. China
Date of Received	:	November 11, 2015
Date of Test	:	November 11, 2015 to December 21, 2015

2.2. Description of Test Facility

Site Description EMC Lab.	:	Accredited by CNAS, 2013.10.29 The certificate is valid until 2016.10.28 The Laboratory has been assessed and proved to be in compliance with CNAS-CL01:2006 (identical to ISO/IEC 17025:2005) The Certificate Registration Number is L2291. Accredited by TUV Rheinland Shenzhen 2010.5.25 The Laboratory has been assessed according to the requirements ISO/IEC 17025. Accredited by FCC, April 17, 2013 The Certificate Registration Number is 709623. Accredited by Industry Canada, November 15, 2010 The Certificate Registration Number is 4480A-2.
Name of Firm	:	EMTEK (SHENZHEN) CO., LTD.
Site Location	:	Bldg 69, Majialong Industry Zone, Nanshan District, Shenzhen, Guangdong, China

2.3. Description of Support Device

PC	:	Manufacturer: LENOVO M/N: 9702 S/N: L3C4410 CE, FCC: DOC
Keyboard	:	Manufacturer: LENOVO M/N: KU-0225 S/N:0585494 CE, FCC: DOC
Mouse	:	Manufacturer: LENOVO M/N: MO28UOL S/N:44G7862 068 CE, FCC: DOC

2.4. Measurement Uncertainty

Test Item	Uncertainty
Conducted Emission Uncertainty	: 2.96dB(9k~150kHz Conduction 1#) 2.74dB(150k-30MHz Conduction 1#)
Radiated Emission Uncertainty (3m Chamber)	: 3.78dB (30M~1GHz Polarize: H) 4.27dB (30M~1GHz Polarize: V) 4.46dB (1~6GHz)

3. MEASURING DEVICE AND TEST EQUIPMENT

3.1. For Power Line Conducted Emission Measurement

Item	Equipment	Manufacturer	Model No.	Serial No.	Last Cal.	Cal. Interval
<input checked="" type="checkbox"/>	Test Receiver	Rohde & Schwarz	ESCI	26115-010-0027	May 16, 2015	1 Year
<input checked="" type="checkbox"/>	L.I.S.N.	Rohde & Schwarz	ENV216	101161	May 16, 2015	1 Year
<input checked="" type="checkbox"/>	50Ω Coaxial Switch	Anritsu	MP59B	6100175589	May 16, 2015	1 Year
<input checked="" type="checkbox"/>	Voltage Probe	Rohde & Schwarz	ESH2-Z3	100122	May 16, 2015	1 Year

3.2. For Radiated Emission Measurement (3m Chamber)

Item	Equipment	Manufacturer	Model No.	Serial No.	Last Cal.	Cal. Interval
<input checked="" type="checkbox"/>	EMI Test Receiver	Rohde & Schwarz	ESU	1302.6005.26	May 16, 2015	1 Year
<input checked="" type="checkbox"/>	Pre-Amplifier	A.H.	PAM-0126	1415261	May 16, 2015	1 Year
<input checked="" type="checkbox"/>	Horn Antenna	Schwarzbeck	BBHA 9120	707	May 16, 2015	1 Year
<input checked="" type="checkbox"/>	Pre-Amplifier	A.H.	PAM-0126	1415261	May 16, 2015	1 Year
<input checked="" type="checkbox"/>	Horn Antenna	Schwarzbeck	BBHA 9120	707	May 16, 2015	1 Year

4. CONDUCTED EMISSION MEASUREMENT

4.1. Block Diagram of Test Setup

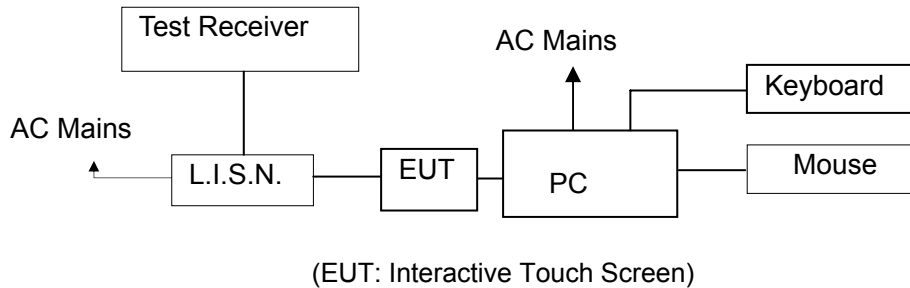

4.2. Measuring Standard

FCC Part 15, Subpart B, Class B ANSI C63.4: 2014

4.3. Power Line Conducted Emission Limits (Class B)

Frequency (MHz)	Limit (dB μ V)	
	Quasi-peak Level	Average Level
0.15 ~ 0.50	66.0 ~ 56.0 *	56.0 ~ 46.0 *
0.50 ~ 5.00	56.0	46.0
5.00 ~ 30.00	60.0	50.0

NOTE1-The lower limit shall apply at the transition frequencies.
NOTE2-The limit decreases linearly with the logarithm of the frequency in the range 0.15MHz to 0.50MHz.

4.4. EUT Configuration on Measurement

The following equipments are installed on Conducted Emission Measurement to meet FCC requirements and operating in a manner which tends to maximize its emission characteristics in a normal application.

EUT : Interactive Touch Screen
Model Number : TT-5515E

4.5. Operating Condition of EUT

4.5.1. Setup the EUT as shown on Section 4.1.

4.5.2. Turn on the power of all equipments.

4.5.3. Let the EUT work in measuring mode (HDD IN, HDMI IN, VGA IN AV IN, Y-Pb-Pr, USB Play) and measure it.

4.6. Test Procedure

The EUT is put on the plane 0.8m high above the ground by insulating support and connected to the AC mains through Line Impedance Stability Network (L.I.S.N). This provided a 50ohm coupling impedance for the tested equipments. Both sides of AC line are investigated to find out the maximum conducted emission according to the FCC regulations during conducted emission measurement.

The bandwidth of the field strength meter (R&S Test Receiver ESCS30) is set at 9kHz in 150kHz~30MHz and 200Hz in 9kHz~150kHz.

The frequency range from 150kHz to 30MHz is investigated.

All the modes were tested and the data of the worst modes are attached the following pages.

4.7. Measuring Results

PASS.

Please refer to the following pages.

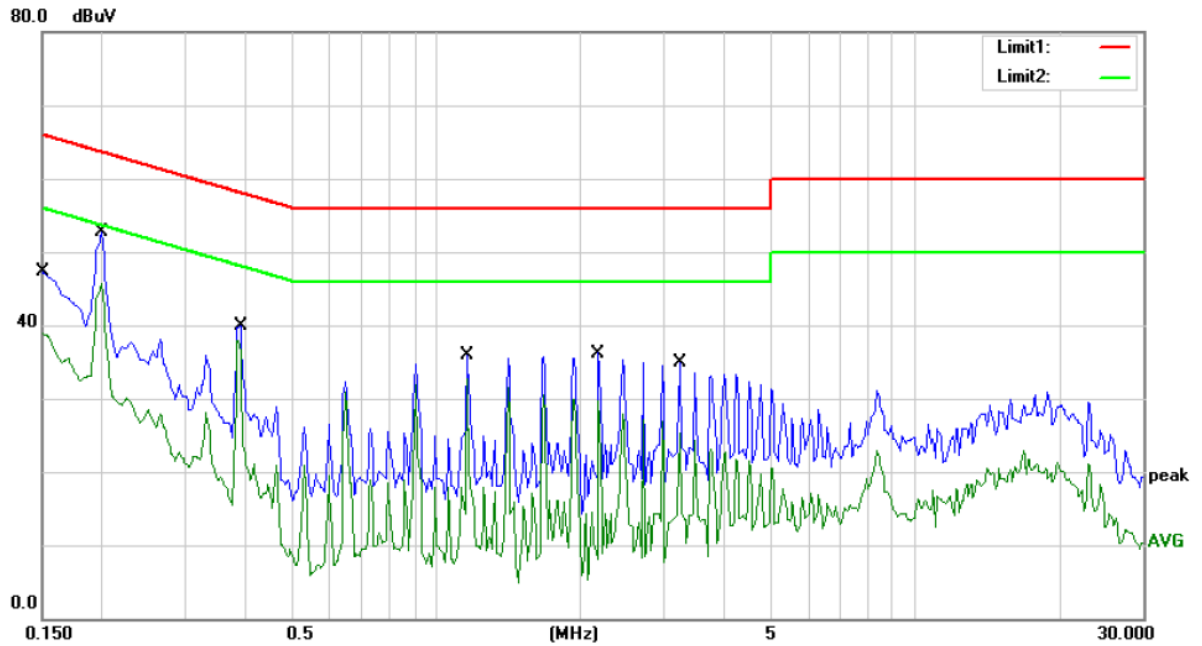

Site Conduction #1 Phase: **L1** Temperature: 22
 Limit: (CE)FCC PART 15 class B_QP Power: AC 120V/60Hz Humidity: 50 %
 Mode: USB PLAY
 Note:

No.	Mk.	Freq.	Reading Level	Correct Factor	Measure-ment	Limit	Over	Detector	Comment
		MHz	dBuV	dB	dBuV	dBuV	dB		
1		0.1500	47.25	0.00	47.25	66.00	-18.75	QP	
2		0.1500	38.95	0.00	38.95	56.00	-17.05	AVG	
3		0.2000	52.71	0.00	52.71	63.61	-10.90	QP	
4	*	0.2000	45.72	0.00	45.72	53.61	-7.89	AVG	
5		0.3900	39.87	0.00	39.87	58.06	-18.19	QP	
6		0.3900	37.94	0.00	37.94	48.06	-10.12	AVG	
7		1.1650	35.83	0.00	35.83	56.00	-20.17	QP	
8		1.1650	32.75	0.00	32.75	46.00	-13.25	AVG	
9		2.1850	36.20	0.00	36.20	56.00	-19.80	QP	
10		2.1850	29.83	0.00	29.83	46.00	-16.17	AVG	
11		3.2350	34.91	0.00	34.91	56.00	-21.09	QP	
12		3.2350	25.33	0.00	25.33	46.00	-20.67	AVG	

*:Maximum data x:Over limit !:over margin Comment: Factor build in receiver. Operator: WGQ

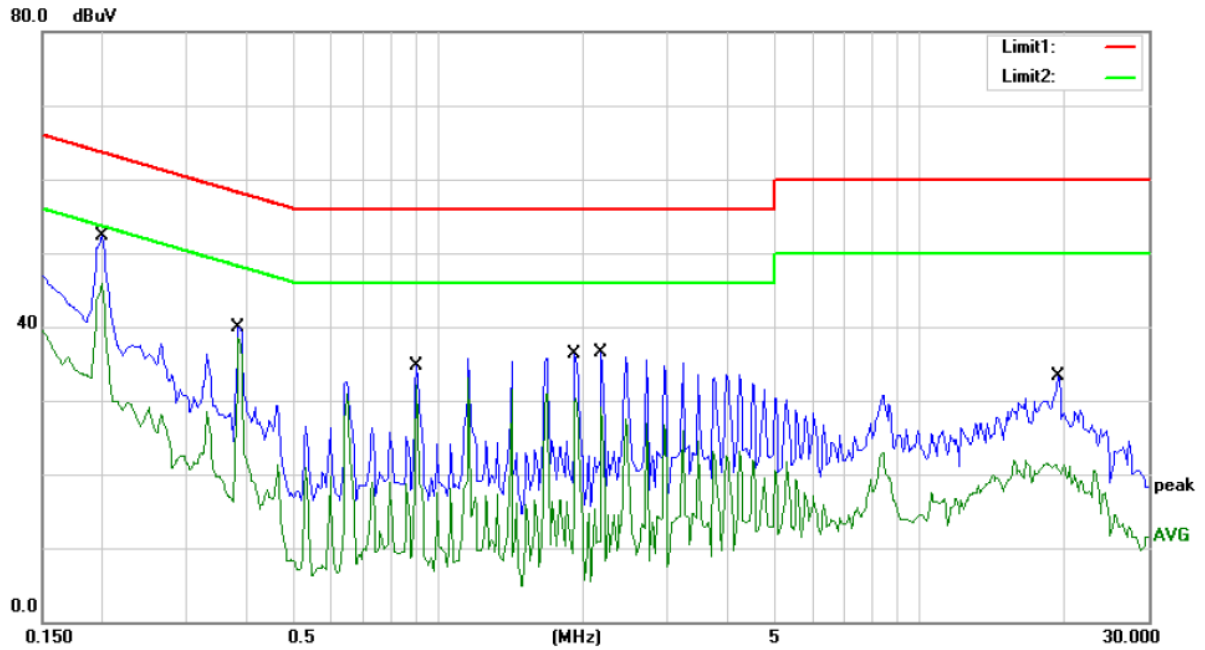

Site Conduction #1

Phase: **N**

Temperature: 22

Limit: (CE)FCC PART 15 class B_QP

Power: AC 120V/60Hz

Humidity: 50 %

Mode: USB PLAY

Note:

No.	Mk.	Freq. MHz	Reading Level dBuV	Correct Factor dB	Measure- ment dBuV	Limit dBuV	Over dB	Detector	Comment
1		0.2000	52.31	0.00	52.31	63.61	-11.30	QP	
2	*	0.2000	45.85	0.00	45.85	53.61	-7.76	AVG	
3		0.3850	39.84	0.00	39.84	58.17	-18.33	QP	
4		0.3850	38.50	0.00	38.50	48.17	-9.67	AVG	
5		0.9000	34.66	0.00	34.66	56.00	-21.34	QP	
6		0.9000	33.11	0.00	33.11	46.00	-12.89	AVG	
7		1.9250	36.34	0.00	36.34	56.00	-19.66	QP	
8		1.9250	30.30	0.00	30.30	46.00	-15.70	AVG	
9		2.1850	36.50	0.00	36.50	56.00	-19.50	QP	
10		2.1850	29.13	0.00	29.13	46.00	-16.87	AVG	
11		19.5250	33.21	0.00	33.21	60.00	-26.79	QP	
12		19.5250	21.39	0.00	21.39	50.00	-28.61	AVG	

*:Maximum data x:Over limit !:over margin Comment: Factor build in receiver. Operator: WGQ

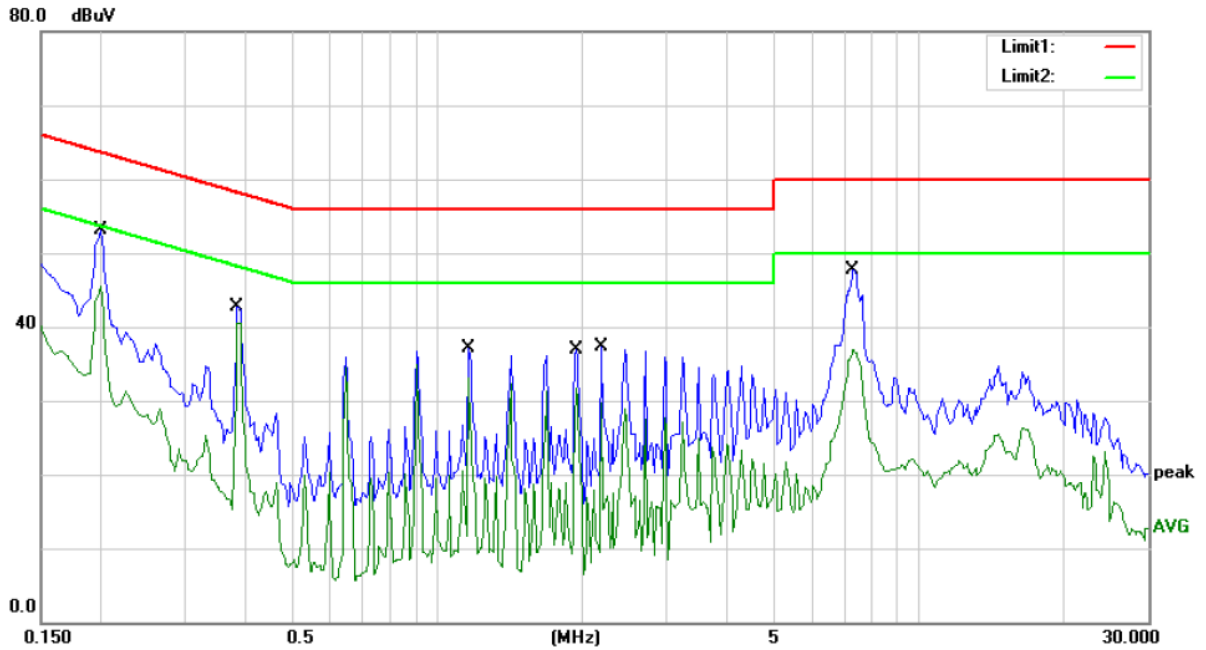

Site Conduction #1

Phase: **L1**

Temperature: 22

Limit: (CE)FCC PART 15 class B_QP

Power: AC 120V/60Hz

Humidity: 50 %

Mode: AV IN

Note:

No. Mk.	Freq. MHz	Reading Level dBuV	Correct Factor dB	Measure- ment dBuV	Limit dBuV	Over dB	Detector	Comment
1	0.2000	53.01	0.00	53.01	63.61	-10.60	QP	
2	0.2000	45.51	0.00	45.51	53.61	-8.10	AVG	
3	0.3850	42.63	0.00	42.63	58.17	-15.54	QP	
4 *	0.3850	40.50	0.00	40.50	48.17	-7.67	AVG	
5	1.1650	37.07	0.00	37.07	56.00	-18.93	QP	
6	1.1650	33.07	0.00	33.07	46.00	-12.93	AVG	
7	1.9450	36.82	0.00	36.82	56.00	-19.18	QP	
8	1.9450	31.71	0.00	31.71	46.00	-14.29	AVG	
9	2.1900	37.31	0.00	37.31	56.00	-18.69	QP	
10	2.1900	29.61	0.00	29.61	46.00	-16.39	AVG	
11	7.3200	47.74	0.00	47.74	60.00	-12.26	QP	
12	7.3200	36.87	0.00	36.87	50.00	-13.13	AVG	

*:Maximum data x:Over limit !:over margin Comment: Factor build in receiver. Operator: WGQ

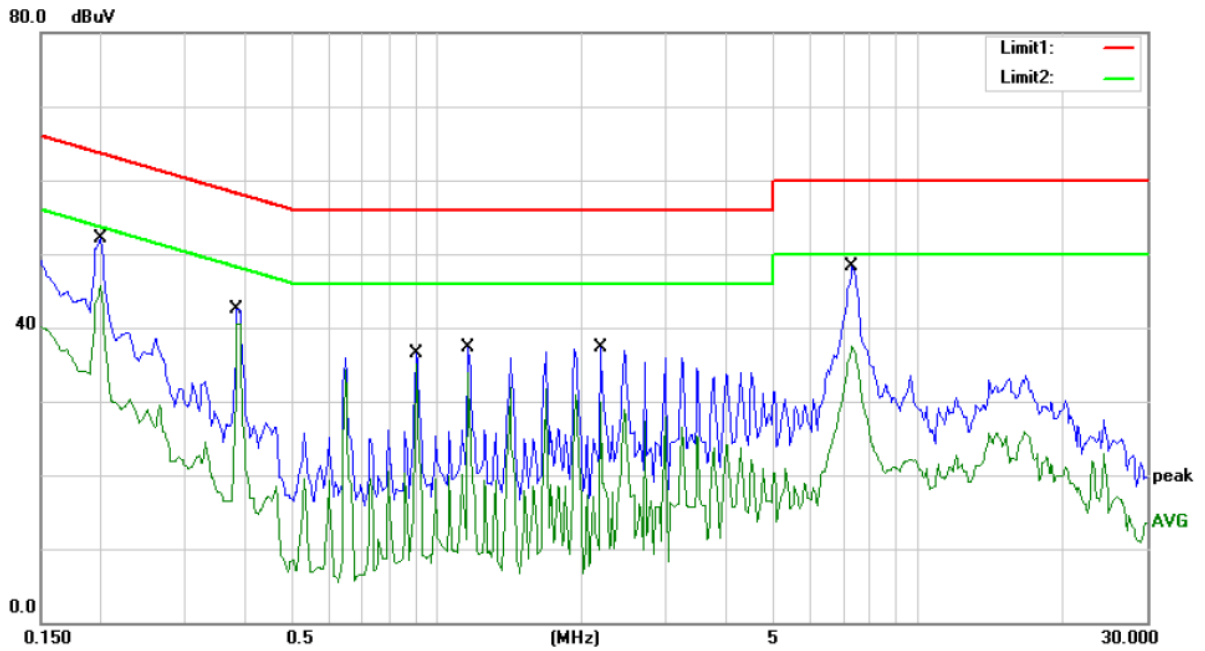

Site Conduction #1

Phase: **N**

Temperature: 22

Limit: (CE)FCC PART 15 class B_QP

Power: AC 120V/60Hz

Humidity: 50 %

Mode: AV IN

Note:

No.	Mk.	Freq.	Reading Level	Correct Factor	Measurement	Limit	Over	Detector	Comment
		MHz	dBuV	dB	dBuV	dBuV	dB		
1		0.2000	52.17	0.00	52.17	63.61	-11.44	QP	
2		0.2000	45.79	0.00	45.79	53.61	-7.82	AVG	
3		0.3850	42.57	0.00	42.57	58.17	-15.60	QP	
4	*	0.3850	40.58	0.00	40.58	48.17	-7.59	AVG	
5		0.9050	36.49	0.00	36.49	56.00	-19.51	QP	
6		0.9050	35.05	0.00	35.05	46.00	-10.95	AVG	
7		1.1650	37.29	0.00	37.29	56.00	-18.71	QP	
8		1.1650	33.90	0.00	33.90	46.00	-12.10	AVG	
9		2.1900	37.40	0.00	37.40	56.00	-18.60	QP	
10		2.1900	31.66	0.00	31.66	46.00	-14.34	AVG	
11		7.3100	48.25	0.00	48.25	60.00	-11.75	QP	
12		7.3100	37.47	0.00	37.47	50.00	-12.53	AVG	

*:Maximum data x:Over limit !:over margin Comment: Factor build in receiver. Operator: WGQ

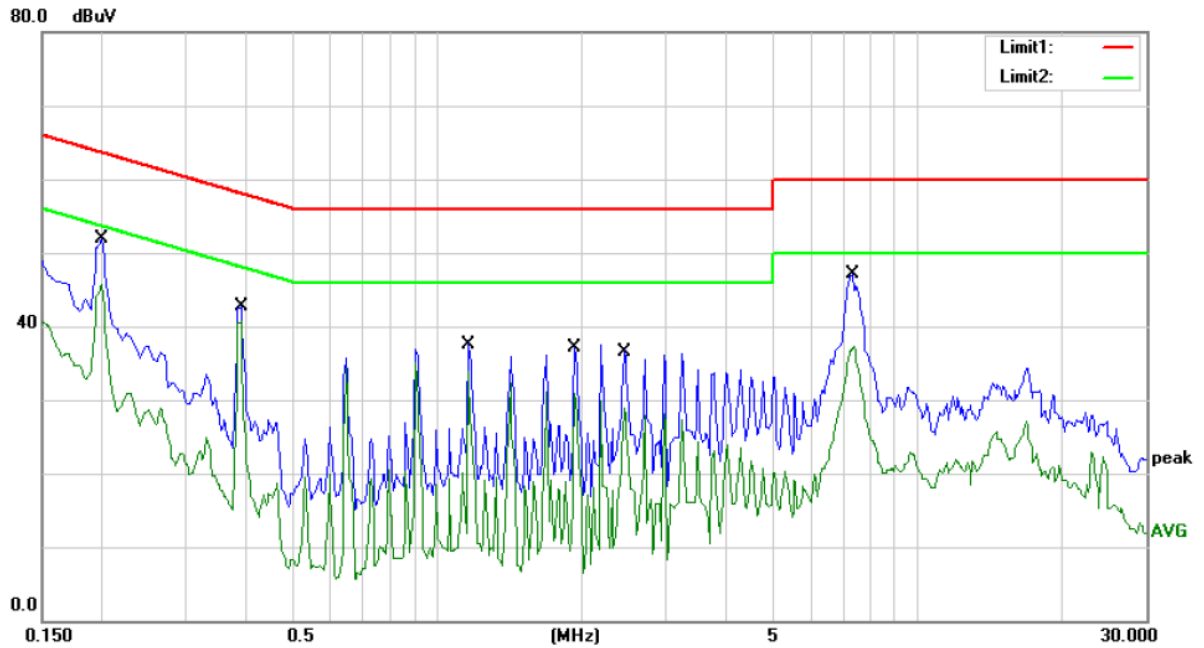

Site Conduction #1

Phase: **L1**

Temperature: 22

Limit: (CE)FCC PART 15 class B_QP

Power: AC 120V/60Hz

Humidity: 50 %

Mode: Y+Pb+Pr

Note:

No.	Mk.	Freq. MHz	Reading Level dBuV	Correct Factor dB	Measure- ment dBuV	Limit dBuV	Over dB	Detector	Comment
1		0.2000	51.91	0.00	51.91	63.61	-11.70	QP	
2		0.2000	45.79	0.00	45.79	53.61	-7.82	AVG	
3		0.3900	42.68	0.00	42.68	58.06	-15.38	QP	
4	*	0.3900	40.66	0.00	40.66	48.06	-7.40	AVG	
5		1.1600	37.60	0.00	37.60	56.00	-18.40	QP	
6		1.1600	33.98	0.00	33.98	46.00	-12.02	AVG	
7		1.9350	37.07	0.00	37.07	56.00	-18.93	QP	
8		1.9350	31.16	0.00	31.16	46.00	-14.84	AVG	
9		2.4550	36.60	0.00	36.60	56.00	-19.40	QP	
10		2.4550	28.95	0.00	28.95	46.00	-17.05	AVG	
11		7.3400	47.10	0.00	47.10	60.00	-12.90	QP	
12		7.3400	37.20	0.00	37.20	50.00	-12.80	AVG	

*:Maximum data x:Over limit !:over margin Comment: Factor build in receiver. Operator: WGQ

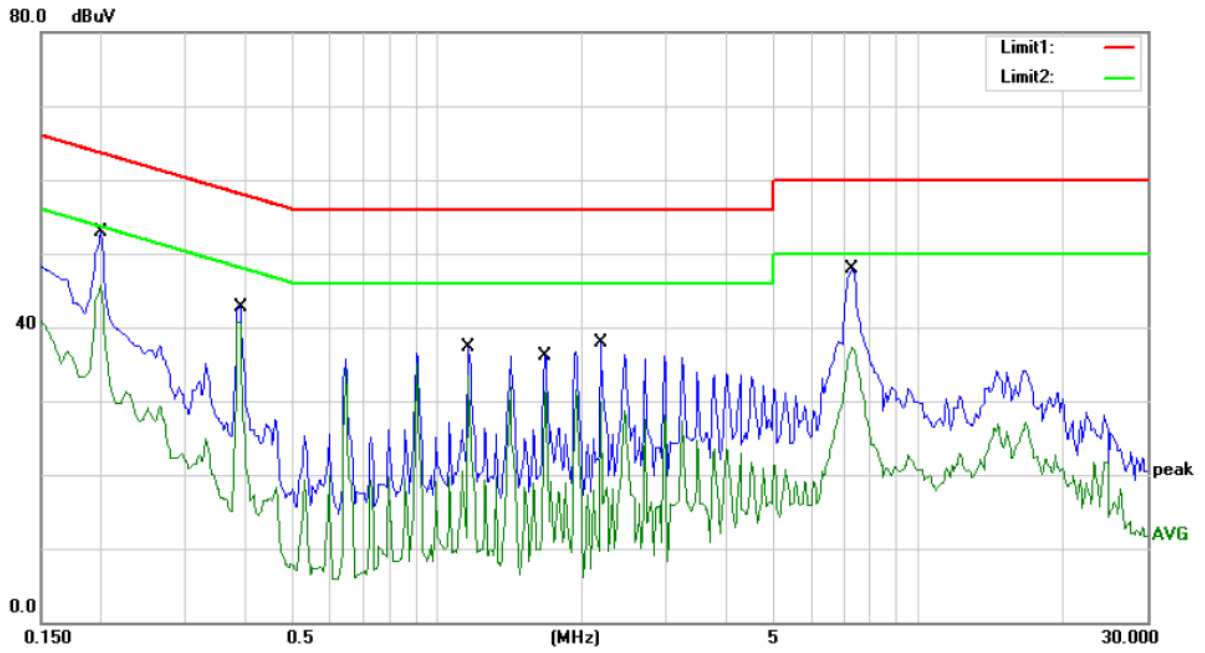

Site Conduction #1

Phase: **N**

Temperature: 22

Limit: (CE)FCC PART 15 class B_QP

Power: AC 120V/60Hz

Humidity: 50 %

Mode: Y+Pb+Pr

Note:

No.	Mk.	Freq. MHz	Reading Level dBuV	Correct Factor dB	Measure- ment dBuV	Limit dBuV	Over dB	Detector	Comment
1		0.2000	52.81	0.00	52.81	63.61	-10.80	QP	
2		0.2000	45.65	0.00	45.65	53.61	-7.96	AVG	
3		0.3900	42.62	0.00	42.62	58.06	-15.44	QP	
4	*	0.3900	40.65	0.00	40.65	48.06	-7.41	AVG	
5		1.1650	37.29	0.00	37.29	56.00	-18.71	QP	
6		1.1650	33.52	0.00	33.52	46.00	-12.48	AVG	
7		1.6800	36.09	0.00	36.09	56.00	-19.91	QP	
8		1.6800	31.43	0.00	31.43	46.00	-14.57	AVG	
9		2.1900	37.84	0.00	37.84	56.00	-18.16	QP	
10		2.1900	29.86	0.00	29.86	46.00	-16.14	AVG	
11		7.3100	47.85	0.00	47.85	60.00	-12.15	QP	
12		7.3100	37.20	0.00	37.20	50.00	-12.80	AVG	

*:Maximum data x:Over limit !:over margin Comment: Factor build in receiver. Operator: WGQ

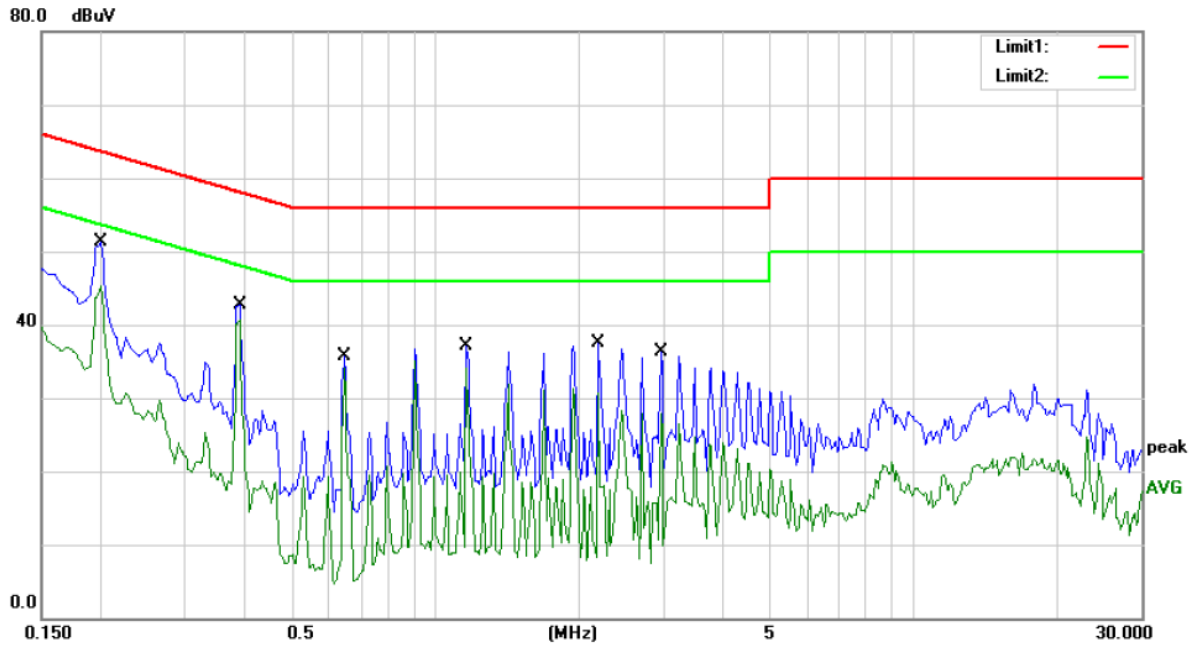

Site Conduction #1

Phase: **L1**

Temperature: 22

Limit: (CE)FCC PART 15 class B_QP

Power: AC 120V/60Hz

Humidity: 50 %

Mode: VGA IN

Note:

No.	Mk.	Freq.	Reading Level	Correct Factor	Measurement	Limit	Over	Detector	Comment
		MHz	dBuV	dB	dBuV	dBuV	dB		
1		0.2000	51.28	0.00	51.28	63.61	-12.33	QP	
2		0.2000	45.21	0.00	45.21	53.61	-8.40	AVG	
3		0.3900	42.72	0.00	42.72	58.06	-15.34	QP	
4	*	0.3900	40.73	0.00	40.73	48.06	-7.33	AVG	
5		0.6450	35.72	0.00	35.72	56.00	-20.28	QP	
6		0.6450	34.16	0.00	34.16	46.00	-11.84	AVG	
7		1.1600	37.03	0.00	37.03	56.00	-18.97	QP	
8		1.1600	34.06	0.00	34.06	46.00	-11.94	AVG	
9		2.1900	37.44	0.00	37.44	56.00	-18.56	QP	
10		2.1900	31.26	0.00	31.26	46.00	-14.74	AVG	
11		2.9750	36.28	0.00	36.28	56.00	-19.72	QP	
12		2.9750	27.89	0.00	27.89	46.00	-18.11	AVG	

*:Maximum data x:Over limit !:over margin Comment: Factor build in receiver. Operator: WGQ

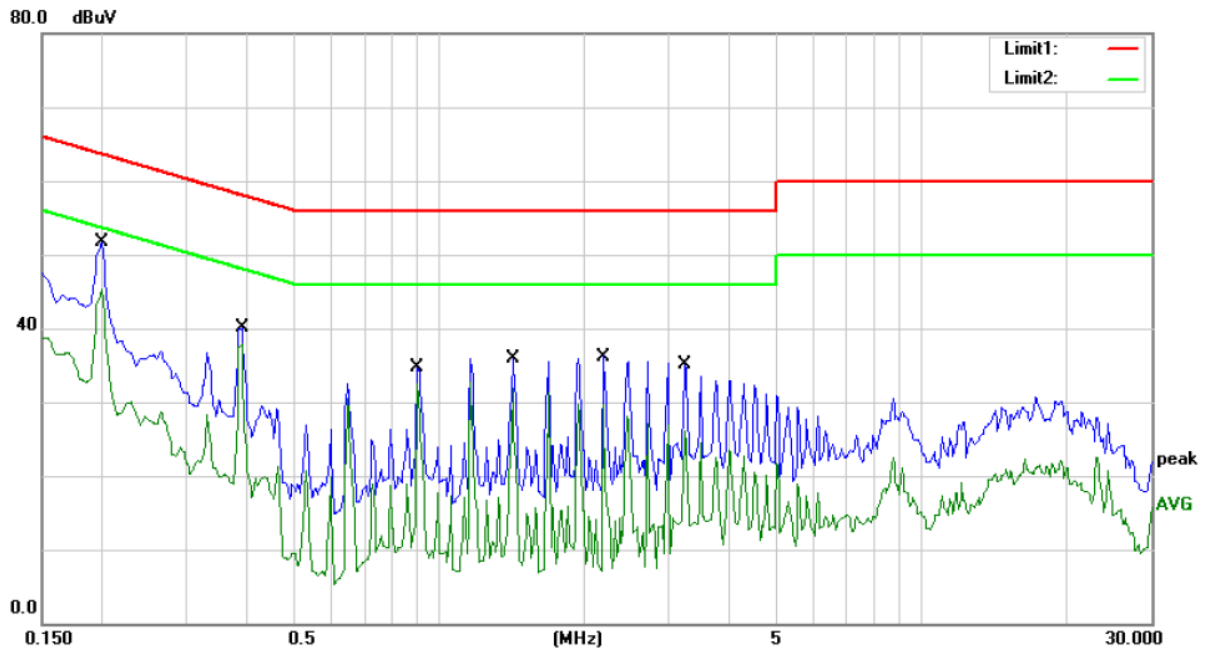

Site Conduction #1

Phase: **N**

Temperature: 22

Limit: (CE)FCC PART 15 class B_QP

Power: AC 120V/60Hz

Humidity: 50 %

Mode: VGA IN

Note:

No.	Mk.	Freq.	Reading Level	Correct Factor	Measurement	Limit	Over	Detector	Comment
		MHz	dBuV	dB	dBuV	dBuV	dB		
1		0.2000	51.79	0.00	51.79	63.61	-11.82	QP	
2	*	0.2000	45.21	0.00	45.21	53.61	-8.40	AVG	
3		0.3900	40.05	0.00	40.05	58.06	-18.01	QP	
4		0.3900	37.95	0.00	37.95	48.06	-10.11	AVG	
5		0.9000	34.80	0.00	34.80	56.00	-21.20	QP	
6		0.9000	32.75	0.00	32.75	46.00	-13.25	AVG	
7		1.4250	35.91	0.00	35.91	56.00	-20.09	QP	
8		1.4250	31.99	0.00	31.99	46.00	-14.01	AVG	
9		2.1900	36.20	0.00	36.20	56.00	-19.80	QP	
10		2.1900	29.61	0.00	29.61	46.00	-16.39	AVG	
11		3.2400	35.01	0.00	35.01	56.00	-20.99	QP	
12		3.2400	27.19	0.00	27.19	46.00	-18.81	AVG	

*:Maximum data x:Over limit !:over margin Comment: Factor build in receiver. Operator: WGQ

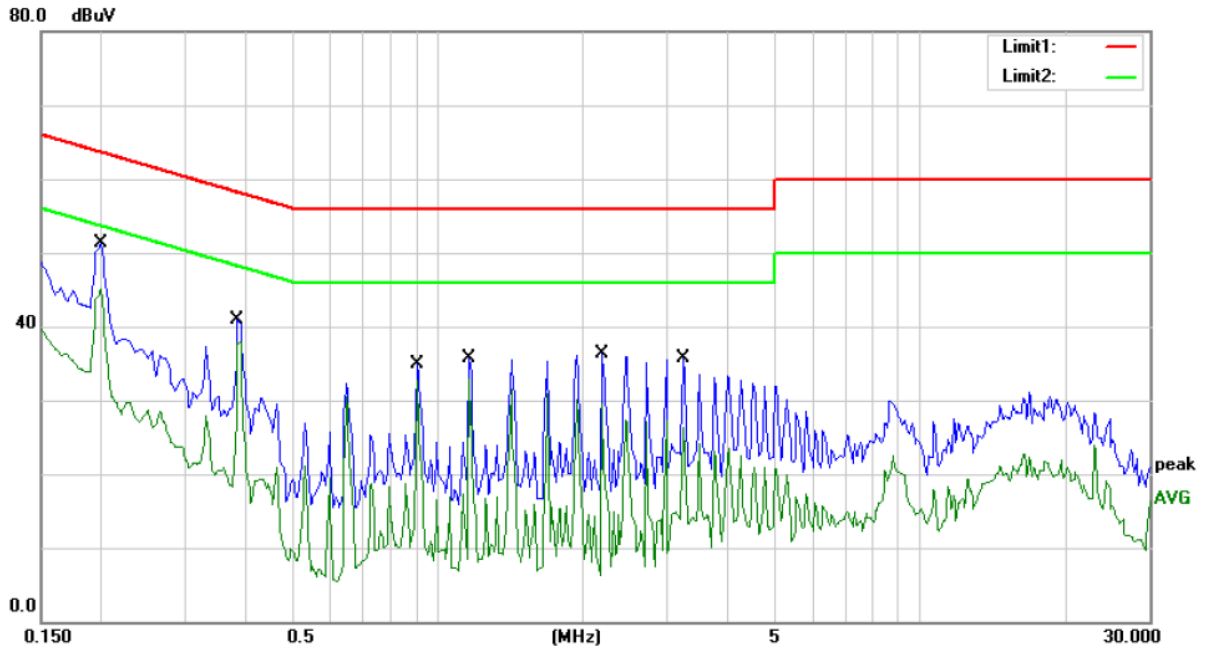

Site Conduction #1

Phase: **L1**

Temperature: 22

Limit: (CE)FCC PART 15 class B_QP

Power: AC 120V/60Hz

Humidity: 50 %

Mode: HDMI IN

Note:

No.	Mk.	Freq.	Reading Level	Correct Factor	Measurement	Limit	Over	Detector	Comment
		MHz	dBuV	dB	dBuV	dBuV	dB		
1		0.2000	51.34	0.00	51.34	63.61	-12.27	QP	
2	*	0.2000	45.07	0.00	45.07	53.61	-8.54	AVG	
3		0.3850	40.84	0.00	40.84	58.17	-17.33	QP	
4		0.3850	37.95	0.00	37.95	48.17	-10.22	AVG	
5		0.9050	34.88	0.00	34.88	56.00	-21.12	QP	
6		0.9050	32.67	0.00	32.67	46.00	-13.33	AVG	
7		1.1600	35.61	0.00	35.61	56.00	-20.39	QP	
8		1.1600	32.94	0.00	32.94	46.00	-13.06	AVG	
9		2.1900	36.22	0.00	36.22	56.00	-19.78	QP	
10		2.1900	29.42	0.00	29.42	46.00	-16.58	AVG	
11		3.2400	35.65	0.00	35.65	56.00	-20.35	QP	
12		3.2400	26.21	0.00	26.21	46.00	-19.79	AVG	

*:Maximum data x:Over limit !:over margin Comment: Factor build in receiver. Operator: WGQ

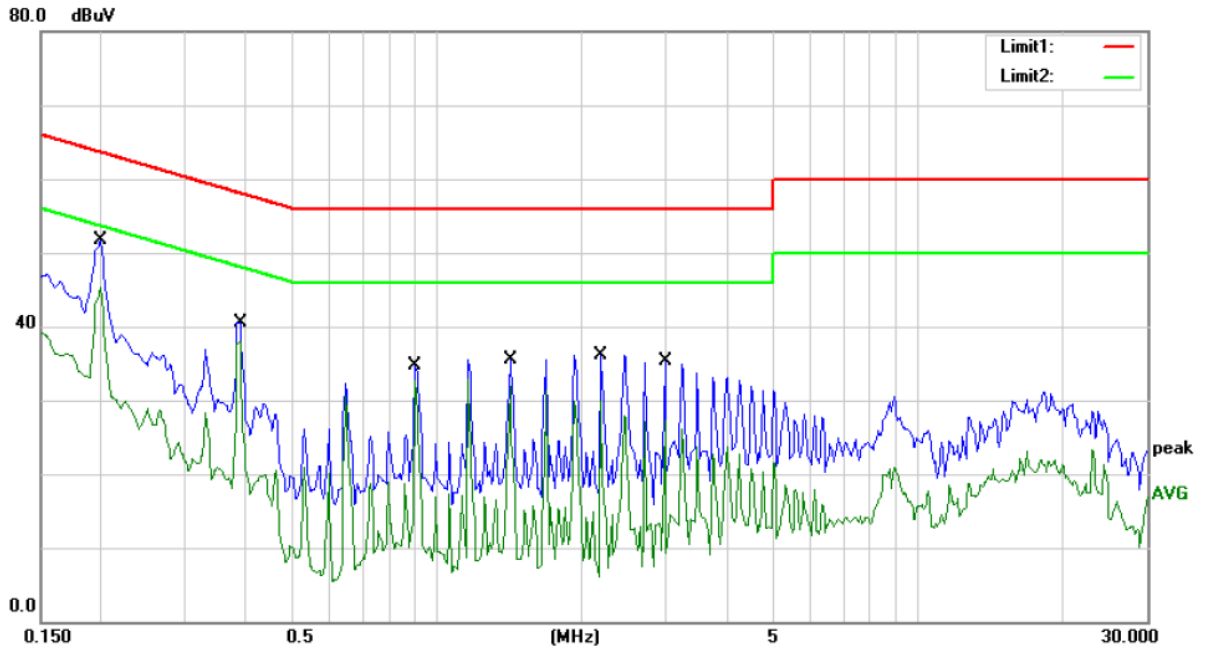

Site Conduction #1

Phase: **N**

Temperature: 22

Limit: (CE)FCC PART 15 class B_QP

Power: AC 120V/60Hz

Humidity: 50 %

Mode: HDMI IN

Note:

No.	Mk.	Freq.	Reading Level	Correct Factor	Measurement	Limit	Over	Detector	Comment
		MHz	dBuV	dB	dBuV	dBuV	dB		
1		0.2000	51.61	0.00	51.61	63.61	-12.00	QP	
2	*	0.2000	45.36	0.00	45.36	53.61	-8.25	AVG	
3		0.3900	40.49	0.00	40.49	58.06	-17.57	QP	
4		0.3900	38.00	0.00	38.00	48.06	-10.06	AVG	
5		0.9000	34.66	0.00	34.66	56.00	-21.34	QP	
6		0.9000	32.98	0.00	32.98	46.00	-13.02	AVG	
7		1.4200	35.52	0.00	35.52	56.00	-20.48	QP	
8		1.4200	31.83	0.00	31.83	46.00	-14.17	AVG	
9		2.1900	36.14	0.00	36.14	56.00	-19.86	QP	
10		2.1900	29.92	0.00	29.92	46.00	-16.08	AVG	
11		2.9800	35.36	0.00	35.36	56.00	-20.64	QP	
12		2.9800	27.23	0.00	27.23	46.00	-18.77	AVG	

*:Maximum data x:Over limit !:over margin Comment: Factor build in receiver. Operator: WGQ

5. RADIATED EMISSION MEASUREMENT

5.1. Block Diagram of Test Setup

5.1.1. Block diagram of EUT System

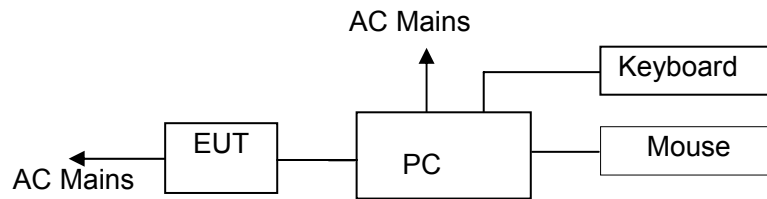

(EUT: Interactive Touch Screen)

5.1.2. Block diagram of test setup (In chamber)

30MHz-1GHz:

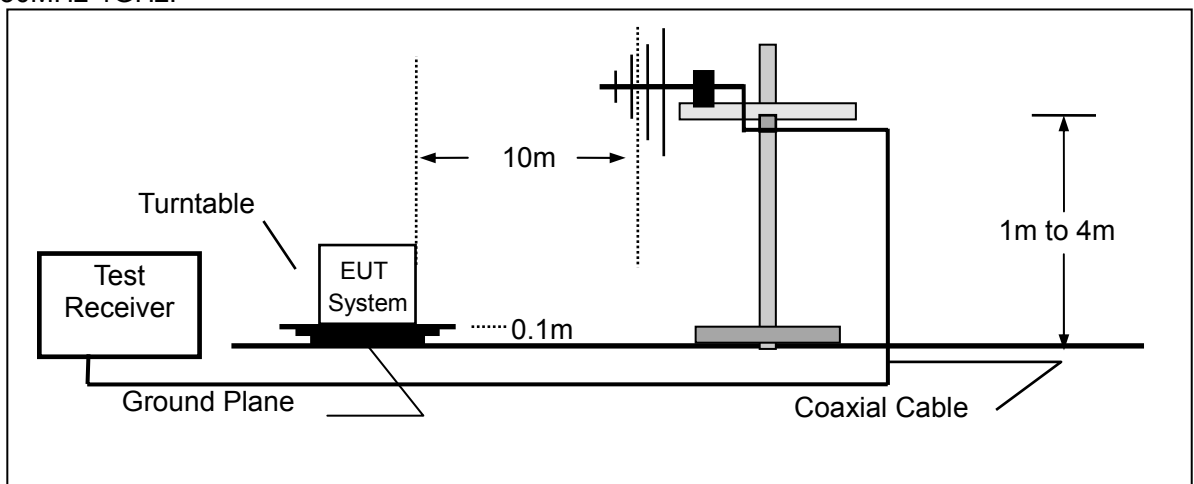

1GHz-6GHz:

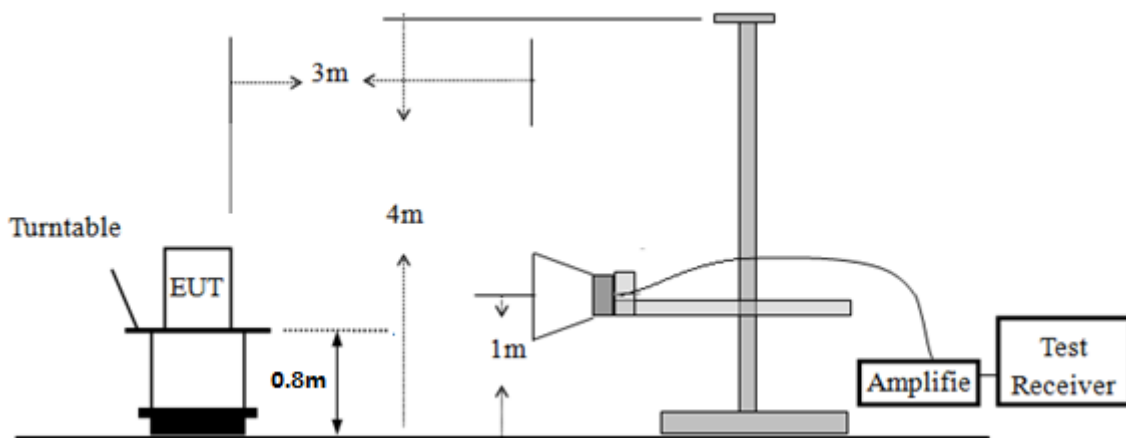

(EUT: Interactive Touch Screen)

5.2. Measuring Standard

FCC Part 15, Subpart B, Class B ANSI C63.4: 2014

5.3. Radiated Emission Limits (Class B)

Frequency MHz	Distance Meters	Field Strengths Limit	
		$\mu\text{V}/\text{m}$	$\text{dB}(\mu\text{V})/\text{m}@10\text{M}$
30 ~ 88	10	100	29.5
88 ~ 216	10	150	33.0
216 ~ 960	10	200	35.5
960 ~ 1000	10	500	43.5

Frequency (GHz)	Distance (Meters)	Field Strengths Limit	
		Average ($\text{dB}\mu\text{V}/\text{m}$)	Peak ($\text{dB}\mu\text{V}/\text{m}$)
1~6	3	54	74

Remark: (1) Emission level ($\text{dB}\mu\text{V}$) = $20 \log$ Emission level $\mu\text{V}/\text{m}$
 (2) The smaller limit shall apply at the cross point between two frequency bands.
 (3) Distance is the distance in meters between the measuring instrument, antenna and the closest point of any part of the device or system.

5.4. EUT Configuration on Measurement

The FCC Class B regulations test method must be used to find the maximum emission during radiated emission measurement.

EUT : Interactive Touch Screen
 Model Number : TT-5515E

5.5. Operating Condition of EUT

5.5.1. Setup the EUT as shown on Section 5.1.

5.5.2. Turn on the power of all equipments.

5.5.3. Let the EUT work in measuring mode (HDD IN, HDMI IN, VGA IN AV IN, Y-Pb-Pr, USB Play) and measure it.

5.6. Test Procedure

The EUT is placed on a turn table which is 0.8 meter high above the ground. The turn table can rotate 360 degrees to determine the position of the maximum emission level. The EUT is set 3 meters away from the receiving antenna which is mounted on a antenna tower. The antenna can be moved up and down from 1 to 4 meters to find out the maximum emission level. Bilog antenna (calibrated by Dipole Antenna) is used as a receiving antenna. Both horizontal and vertical polarization of the antenna are set on test.

The bandwidth of the Receiver (ESU26) is set at 120kHz.

All the modes were tested and the data of the worst modes are attached the following pages.

5.7. Measuring Results

PASS.

The frequency range from 30MHz to 6000MHz is investigated.

Please refer to the following pages.

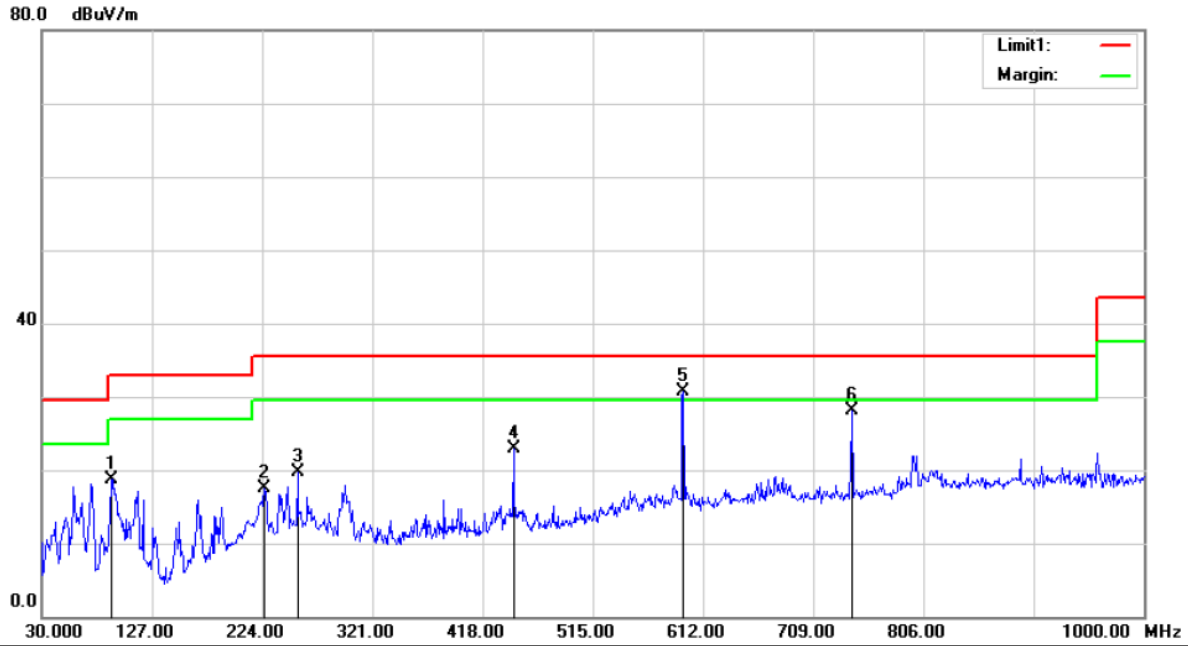

Site :10m Chamber #1

Polarization: *Horizontal*

Temperature: 26

Limit: (RE 10M)FCC 15 Class B

Power: AC 120V/60Hz

Humidity: 60 %

Mode:HDMI IN

Note:

No.	Mk.	Freq.	Reading Level	Correct Factor	Measurement	Limit	Over	Antenna Height	Table Degree	
		MHz	dBuV	dB	dBuV/m	dBuV/m	dB	cm	degree	Comment
1		91.1100	52.52	-33.80	18.72	33.00	-14.28	308	212	
2		225.9400	48.75	-31.34	17.41	35.50	-18.09	400	183	
3		255.0400	50.33	-30.54	19.79	35.50	-15.71	400	48	
4		445.1600	49.23	-26.40	22.83	35.50	-12.67	400	39	
5	*	594.5400	54.26	-23.47	30.79	35.50	-4.71	308	359	
6		742.9500	49.62	-21.46	28.16	35.50	-7.34	308	3	

*:Maximum data x:Over limit !:over margin

Operator: CSL

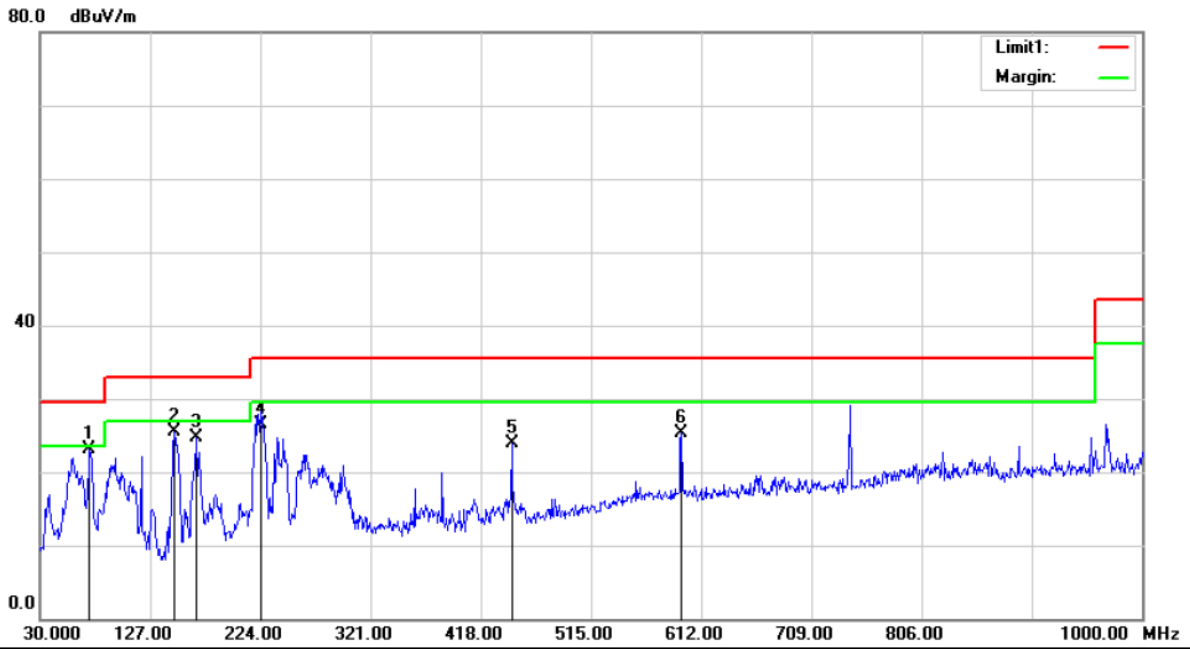

Site :10m Chamber #1 Polarization: **Vertical** Temperature: 26
 Limit: (RE 10M)FCC 15 Class B Power: AC 120V/60Hz Humidity: 60 %
 Mode:HDMI IN
 Note:

No.	Mk.	Freq. MHz	Reading Level dBuV	Correct Factor dB	Measure- ment dBuV/m	Limit dBuV/m	Over dB	Detector	Antenna Height cm	Table Degree	Comment
1	*	73.6500	57.70	-34.58	23.12	29.50	-6.38	QP	100	162	
2		148.3400	60.21	-34.78	25.43	33.00	-7.57	QP	200	179	
3		167.7400	58.54	-33.83	24.71	33.00	-8.29	QP	100	211	
4		224.0000	56.84	-30.34	26.50	35.50	-9.00	QP	200	189	
5		445.1600	48.81	-24.90	23.91	35.50	-11.59	QP	200	359	
6		594.5400	46.96	-21.68	25.28	35.50	-10.22	QP	200	359	

*:Maximum data x:Over limit !:over margin

Operator: CSL

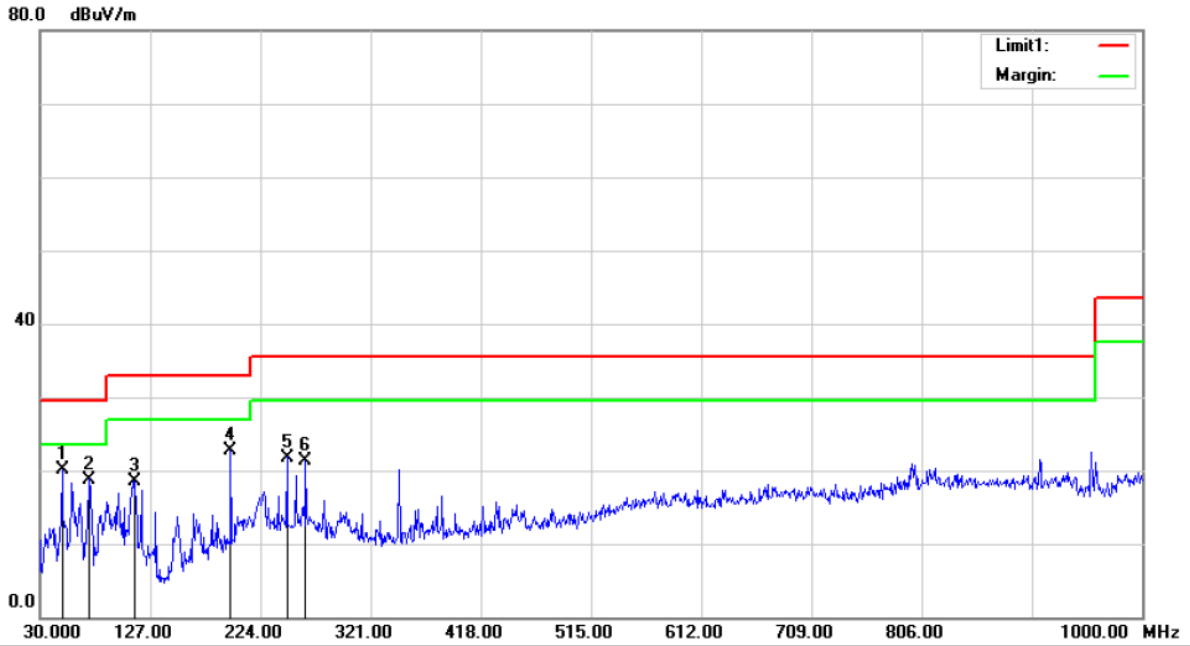

Site :10m Chamber #1 Polarization: *Horizontal* Temperature: 26
 Limit: (RE 10M)FCC 15 Class B Power: AC 120V/60Hz Humidity: 60 %
 Mode:VGA IN
 Note:

No.	Mk.	Freq.	Reading Level	Correct Factor	Measurement	Limit	Over	Antenna Height	Table Degree	
		MHz	dBuV	dB	dBuV/m	dBuV/m	dB	cm	degree	Comment
1	*	49.4000	50.47	-30.40	20.07	29.50	-9.43	309	359	
2		73.6500	54.00	-35.20	18.80	29.50	-10.70	309	353	
3		113.4200	51.48	-32.96	18.52	33.00	-14.48	400	184	
4		197.8100	55.08	-32.28	22.80	33.00	-10.20	400	125	
5		247.2800	52.53	-30.73	21.80	35.50	-13.70	400	193	
6		263.7700	51.63	-30.33	21.30	35.50	-14.20	400	0	

*:Maximum data x:Over limit !:over margin

Operator: CSL

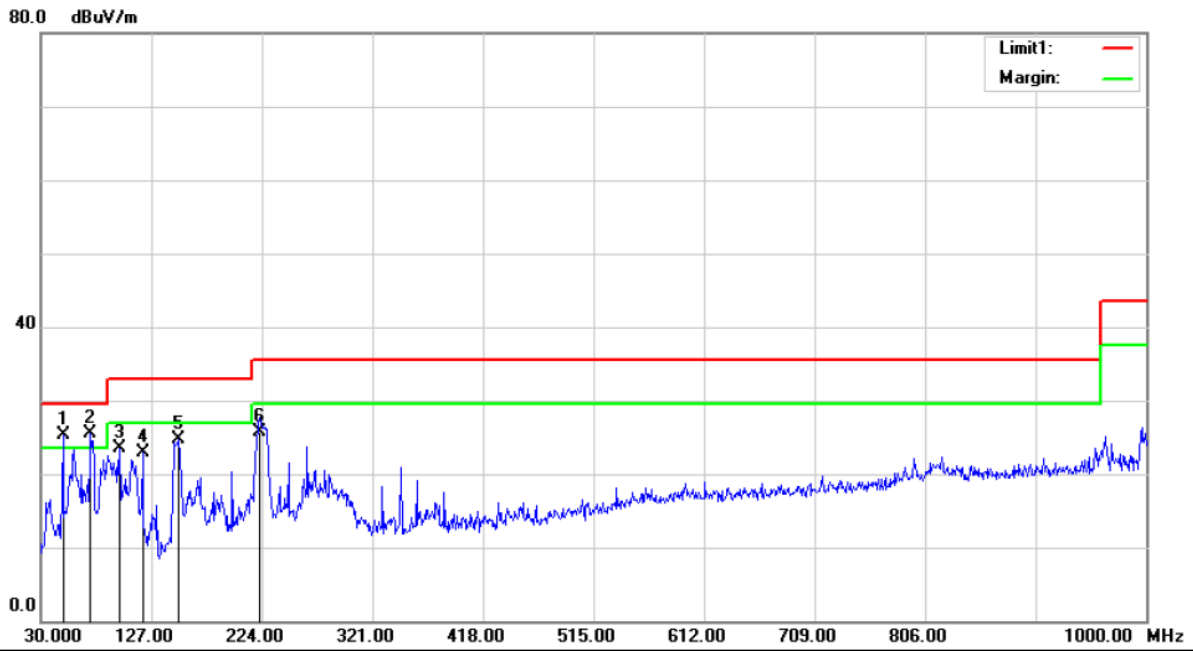

Site :10m Chamber #1

Polarization: *Vertical*

Temperature: 26

Limit: (RE 10M)FCC 15 Class B

Power: AC 120V/60Hz

Humidity: 60 %

Mode:VGA IN

Note:

No.	Mk.	Freq.	Reading Level	Correct Factor	Measurement	Limit	Over	Antenna Height	Table Degree	
		MHz	dBuV	dB	dBuV/m	dBuV/m	dB	cm	degree	Comment
1	!	49.4000	55.25	-29.91	25.34	29.50	-4.16	QP	100	260
2	*	73.6500	60.09	-34.58	25.51	29.50	-3.99	QP	199	150
3		98.8700	55.41	-31.82	23.59	33.00	-9.41	QP	100	107
4		119.2400	56.12	-33.16	22.96	33.00	-10.04	QP	100	155
5		151.2500	59.41	-34.66	24.75	33.00	-8.25	QP	100	208
6		222.0600	56.10	-30.40	25.70	35.50	-9.80	QP	100	165

*:Maximum data x:Over limit !:over margin

Operator: CSL

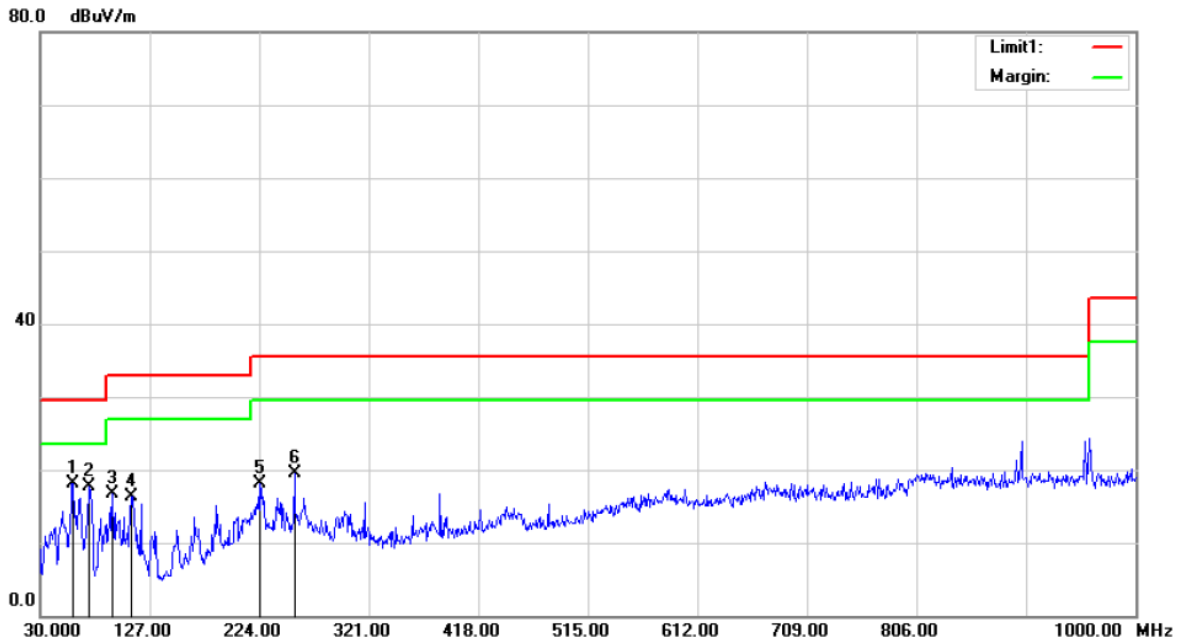

Site :10m Chamber #1 Polarization: *Horizontal* Temperature: 26
 Limit: (RE 10M)FCC 15 Class B Power: AC 120V/60Hz Humidity: 60 %
 Mode:USB PLAY
 Note:

No.	Mk.	Freq.	Reading Level	Correct Factor	Measurement	Limit	Over	Antenna Height	Table Degree	
		MHz	dBuV	dB	dBuV/m	dBuV/m	dB	cm	degree	Comment
1	*	59.1000	49.94	-31.80	18.14	29.50	-11.36	QP	400	267
2		73.6500	52.91	-35.20	17.71	29.50	-11.79	QP	308	165
3		94.0200	49.93	-33.32	16.61	33.00	-16.39	QP	308	186
4		110.5100	48.80	-32.48	16.32	33.00	-16.68	QP	400	190
5		224.0000	49.57	-31.38	18.19	35.50	-17.31	QP	308	268
6		255.0400	50.09	-30.54	19.55	35.50	-15.95	QP	308	359

*:Maximum data x:Over limit !:over margin

Operator: CSL

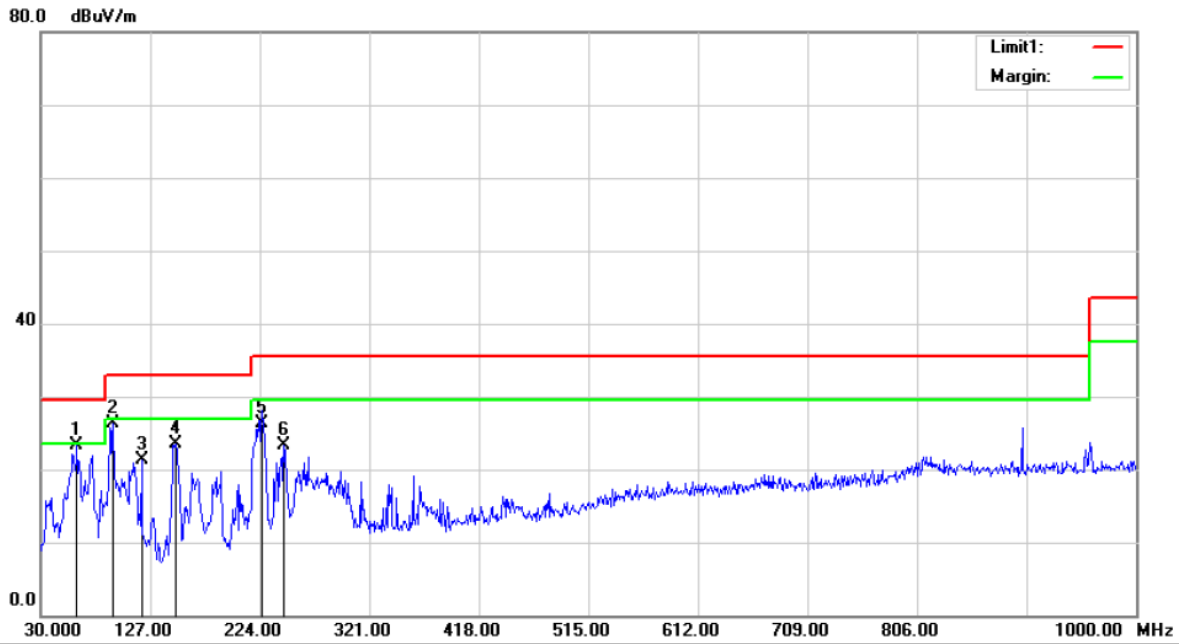

Site :10m Chamber #1

Polarization: *Vertical*

Temperature: 26

Limit: (RE 10M)FCC 15 Class B

Power: AC 120V/60Hz

Humidity: 60 %

Mode:USB PLAY

Note:

No.	Mk.	Freq.	Reading Level	Correct Factor	Measurement	Limit	Over	Antenna Height	Table Degree	
		MHz	dBuV	dB	dBuV/m	dBuV/m	dB	cm	degree	Comment
1	*	62.0100	53.62	-30.30	23.32	29.50	-6.18	200	160	
2		94.0200	58.87	-32.64	26.23	33.00	-6.77	100	220	
3		119.2400	54.53	-33.16	21.37	33.00	-11.63	100	162	
4		149.3100	58.21	-34.74	23.47	33.00	-9.53	100	192	
5		225.9400	56.59	-30.29	26.30	35.50	-9.20	100	176	
6		245.3400	53.04	-29.70	23.34	35.50	-12.16	100	146	

*:Maximum data x:Over limit !:over margin

Operator: CSL

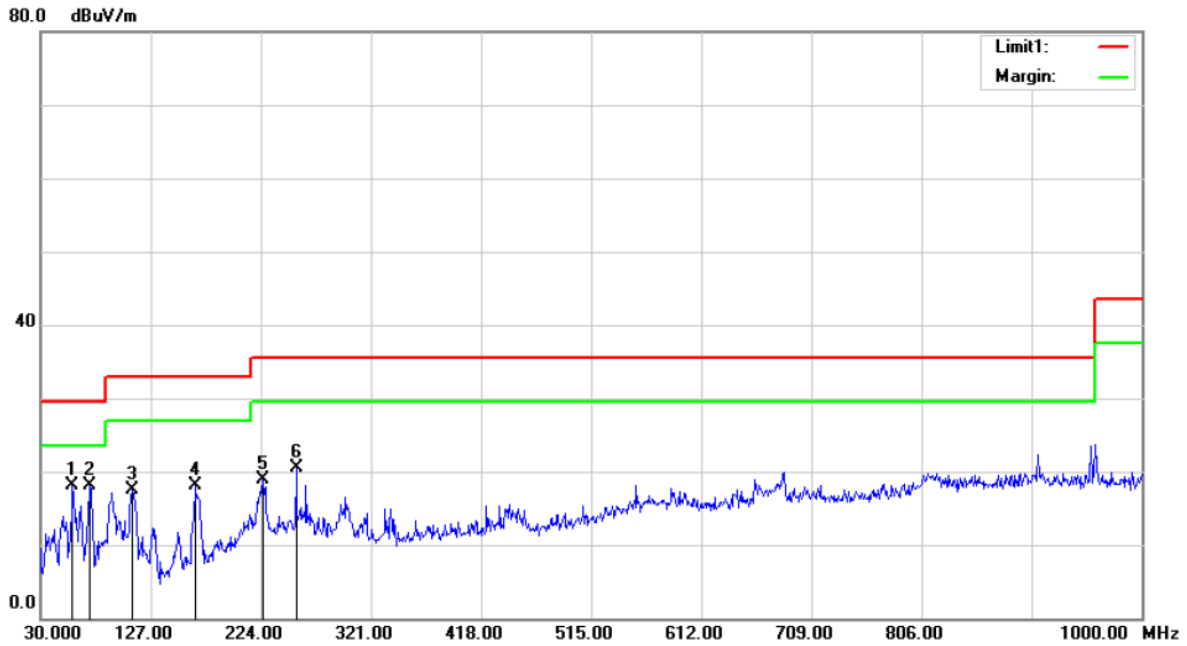

Site :10m Chamber #1 Polarization: **Horizontal** Temperature: 26
 Limit: (RE 10M)FCC 15 Class B Power: AC 120V/60Hz Humidity: 60 %
 Mode:AV IN
 Note:

No.	Mk.	Freq.	Reading Level	Correct Factor	Measurement	Limit	Over	Antenna Height	Table Degree	
		MHz	dBuV	dB	dBuV/m	dBuV/m	dB	cm	degree	Comment
1	*	58.1300	49.83	-31.64	18.19	29.50	-11.31	400	331	
2		73.6500	53.29	-35.20	18.09	29.50	-11.41	400	343	
3		110.5100	49.94	-32.48	17.46	33.00	-15.54	400	208	
4		165.8000	53.00	-34.86	18.14	33.00	-14.86	308	156	
5		225.9400	50.18	-31.34	18.84	35.50	-16.66	400	243	
6		255.0400	51.06	-30.54	20.52	35.50	-14.98	400	0	

*:Maximum data x:Over limit !:over margin

Operator: CSL

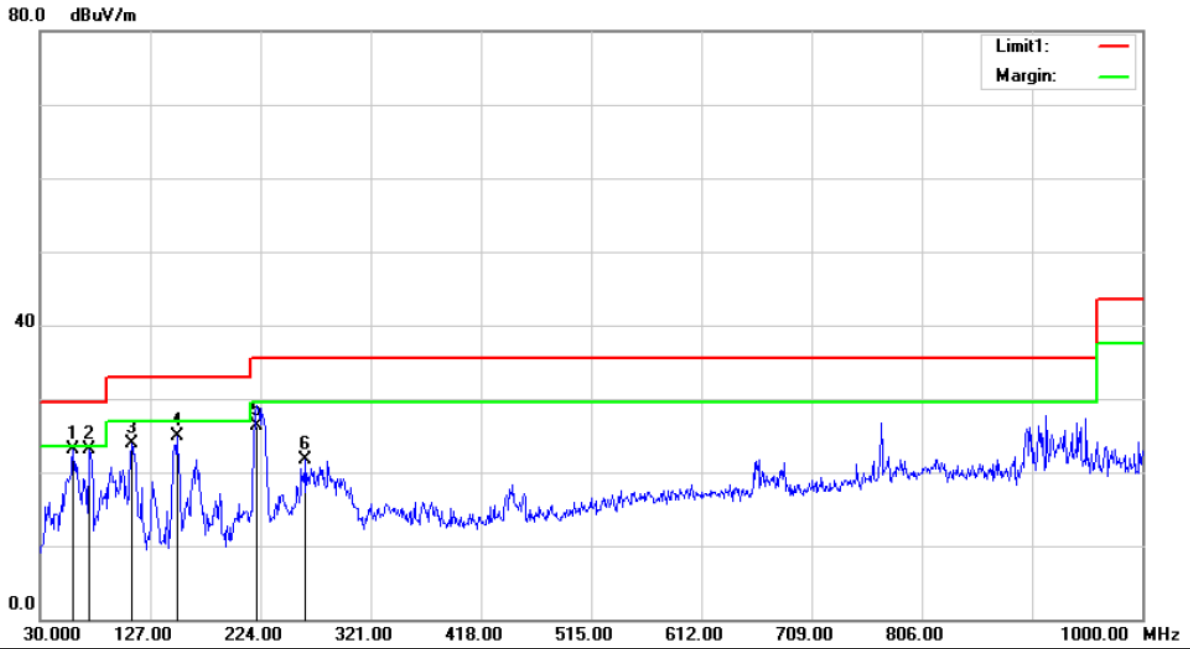

Site :10m Chamber #1

Polarization: *Vertical*

Temperature: 26

Limit: (RE 10M)FCC 15 Class B

Power: AC 120V/60Hz

Humidity: 60 %

Mode:AV IN

Note:

No.	Mk.	Freq.	Reading Level	Correct Factor	Measurement	Limit	Over	Antenna Height	Table Degree	
		MHz	dBuV	dB	dBuV/m	dBuV/m	dB	cm	degree	Comment
1	*	59.1000	52.61	-29.44	23.17	29.50	-6.33	QP 100	181	
2		73.6500	57.63	-34.58	23.05	29.50	-6.45	QP 200	142	
3		110.5100	55.64	-31.74	23.90	33.00	-9.10	QP 100	162	
4		150.2800	59.52	-34.70	24.82	33.00	-8.18	QP 100	188	
5		221.0900	56.83	-30.43	26.40	35.50	-9.10	QP 100	162	
6		263.7700	50.91	-29.20	21.71	35.50	-13.79	QP 100	239	

*:Maximum data x:Over limit !:over margin

Operator: CSL

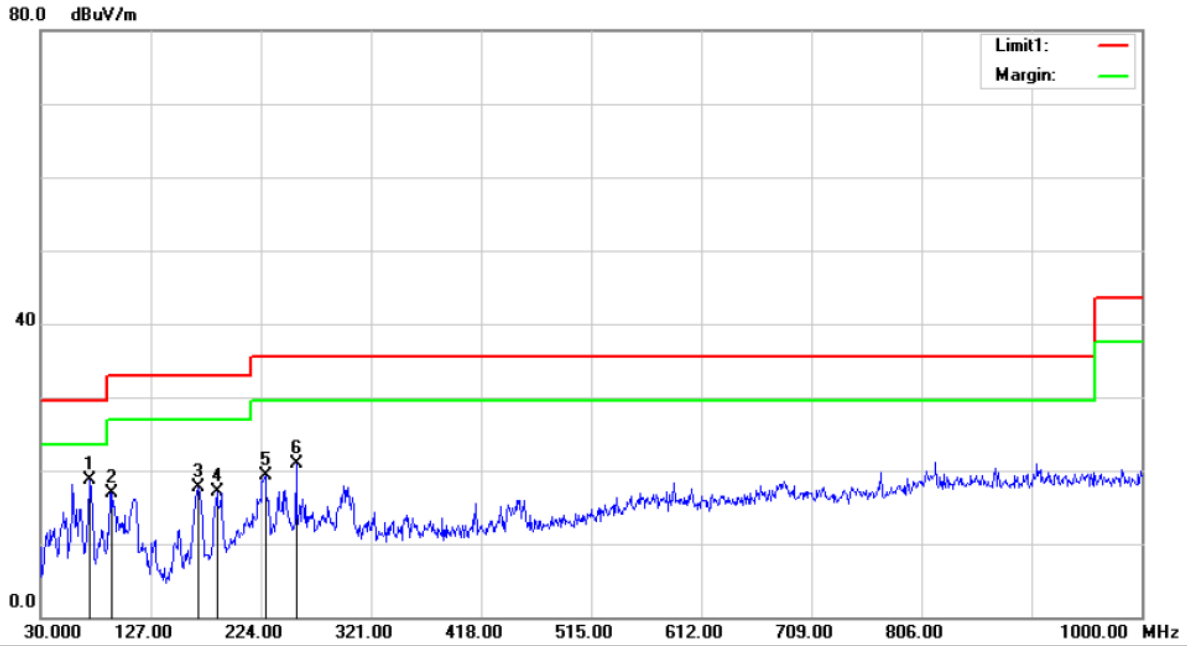

Site :10m Chamber #1 Polarization: *Horizontal* Temperature: 26
 Limit: (RE 10M)FCC 15 Class B Power: AC 120V/60Hz Humidity: 60 %
 Mode:Y-Yb-Yr
 Note:

No.	Mk.	Freq.	Reading Level	Correct Factor	Measurement	Limit	Over	Antenna Height	Table Degree	
		MHz	dBuV	dB	dBuV/m	dBuV/m	dB	cm	degree	Comment
1	*	73.6500	53.95	-35.20	18.75	29.50	-10.75	308	359	
2		93.0500	50.40	-33.48	16.92	33.00	-16.08	400	183	
3		168.7100	52.48	-34.69	17.79	33.00	-15.21	400	146	
4		185.2000	50.58	-33.54	17.04	33.00	-15.96	308	150	
5		227.8800	50.50	-31.28	19.22	35.50	-16.28	308	194	
6		255.0400	51.39	-30.54	20.85	35.50	-14.65	400	350	

*:Maximum data x:Over limit !:over margin

Operator: CSL

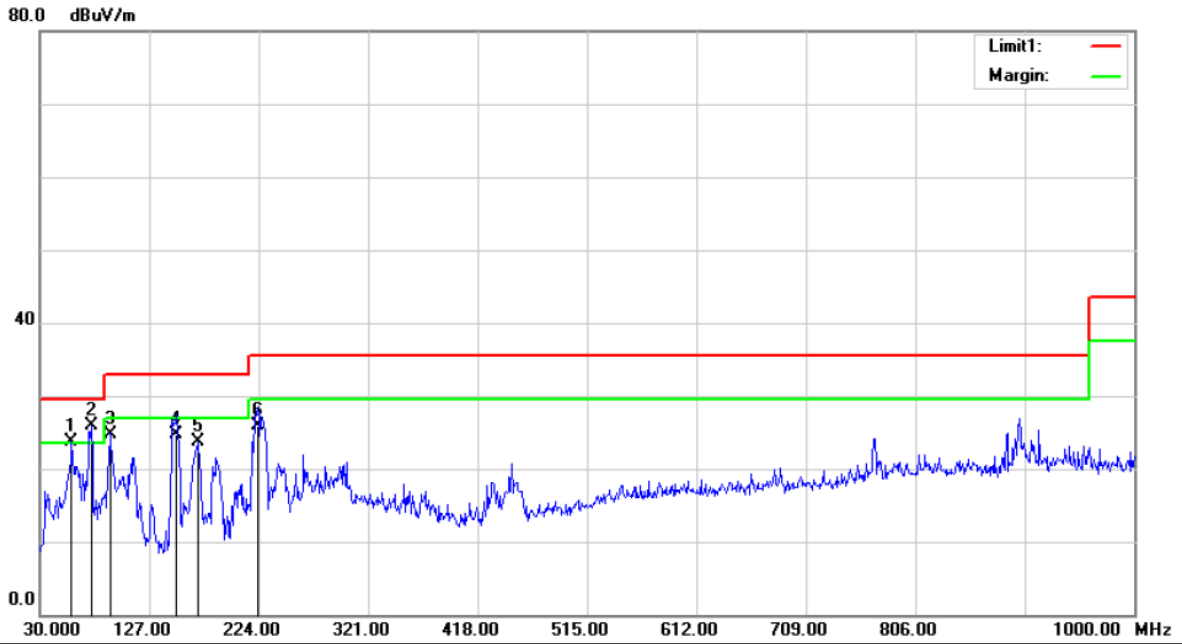

Site :10m Chamber #1 Polarization: **Vertical** Temperature: 26
 Limit: (RE 10M)FCC 15 Class B Power: AC 120V/60Hz Humidity: 60 %
 Mode:Y-Yb-Yr
 Note:

No.	Mk.	Freq.	Reading Level	Correct Factor	Measurement	Limit	Over	Antenna Height	Table Degree		
		MHz	dBuV	dB	dBuV/m	dBuV/m	dB	Detector	cm	degree	Comment
1	!	58.1300	53.09	-29.48	23.61	29.50	-5.89	QP	100	160	
2	*	75.5900	60.76	-34.94	25.82	29.50	-3.68	QP	200	148	
3		92.0800	57.77	-32.97	24.80	33.00	-8.20	QP	100	160	
4		151.2500	59.46	-34.66	24.80	33.00	-8.20	QP	100	199	
5		169.6800	57.38	-33.72	23.66	33.00	-9.34	QP	100	127	
6		223.0300	56.27	-30.37	25.90	35.50	-9.60	QP	100	275	

*:Maximum data x:Over limit !:over margin

Operator: CSL

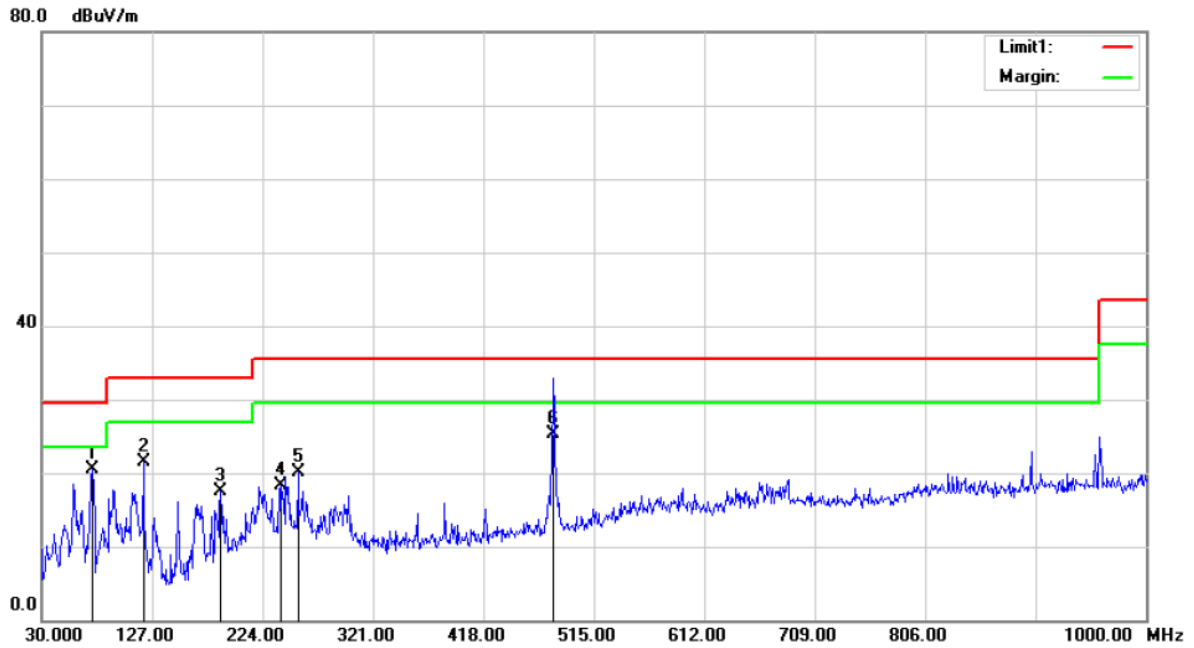

Site :10m Chamber #1

Polarization: *Horizontal*

Temperature: 26

Limit: (RE 10M)FCC 15 Class B

Power: AC 120V/60Hz

Humidity: 60 %

Mode:HDD PLAY

Note:

No.	Mk.	Freq.	Reading Level	Correct Factor	Measurement	Limit	Over	Antenna Height	Table Degree	
		MHz	dBuV	dB	dBuV/m	dBuV/m	dB	cm	degree	Comment
1	*	74.6200	55.91	-35.39	20.52	29.50	-8.98	400	344	
2		119.2400	55.41	-33.93	21.48	33.00	-11.52	400	198	
3		187.1400	50.84	-33.34	17.50	33.00	-15.50	400	226	
4		239.5200	49.17	-30.94	18.23	35.50	-17.27	400	3	
5		255.0400	50.69	-30.54	20.15	35.50	-15.35	400	226	
6		479.1100	51.12	-25.82	25.30	35.50	-10.20	400	282	

*:Maximum data x:Over limit !:over margin

Operator: CSL

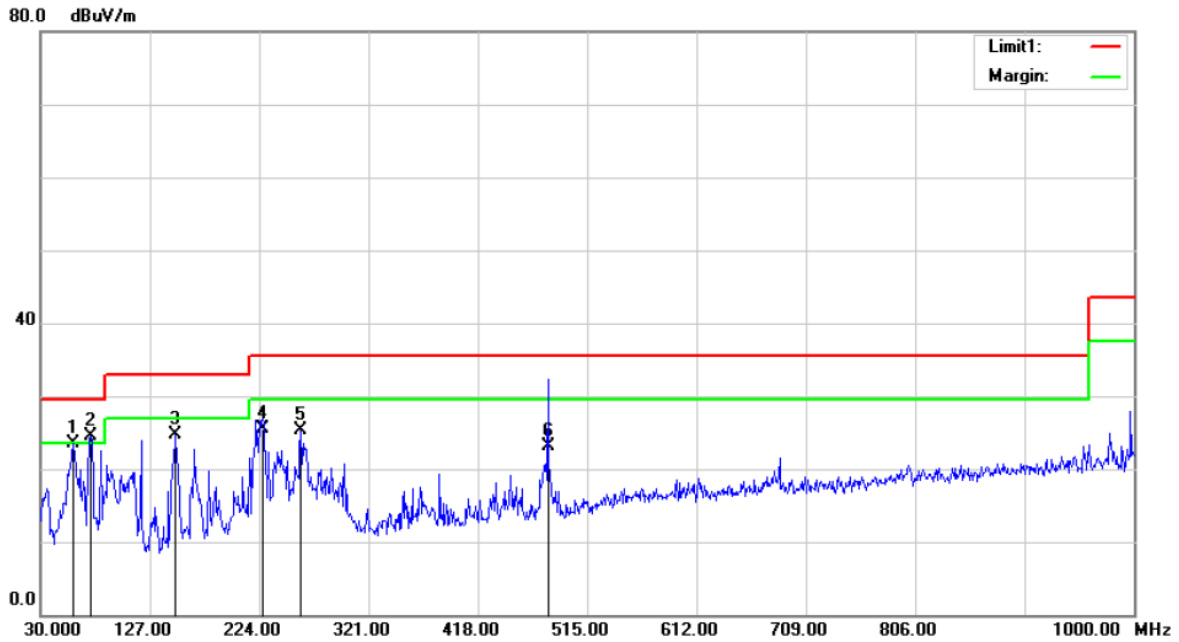

Site :10m Chamber #1 Polarization: *Vertical* Temperature: 26
 Limit: (RE 10M)FCC 15 Class B Power: AC 120V/60Hz Humidity: 60 %
 Mode:HDD PLAY
 Note:

No.	Mk.	Freq.	Reading Level	Correct Factor	Measurement	Limit	Over	Antenna Height	Table Degree		
		MHz	dBuV	dB	dBuV/m	dBuV/m	dB	Detector	cm	degree	Comment
1	!	59.1000	52.99	-29.44	23.55	29.50	-5.95	QP	100	1	
2	*	74.6200	59.24	-34.77	24.47	29.50	-5.03	QP	100	182	
3		149.3100	59.39	-34.74	24.65	33.00	-8.35	QP	100	237	
4		226.9100	55.85	-30.25	25.60	35.50	-9.90	QP	100	217	
5		260.8600	54.67	-29.27	25.40	35.50	-10.10	QP	100	224	
6		480.0800	47.34	-24.24	23.10	35.50	-12.40	QP	100	1	

*:Maximum data x:Over limit !:over margin

Operator: CSL

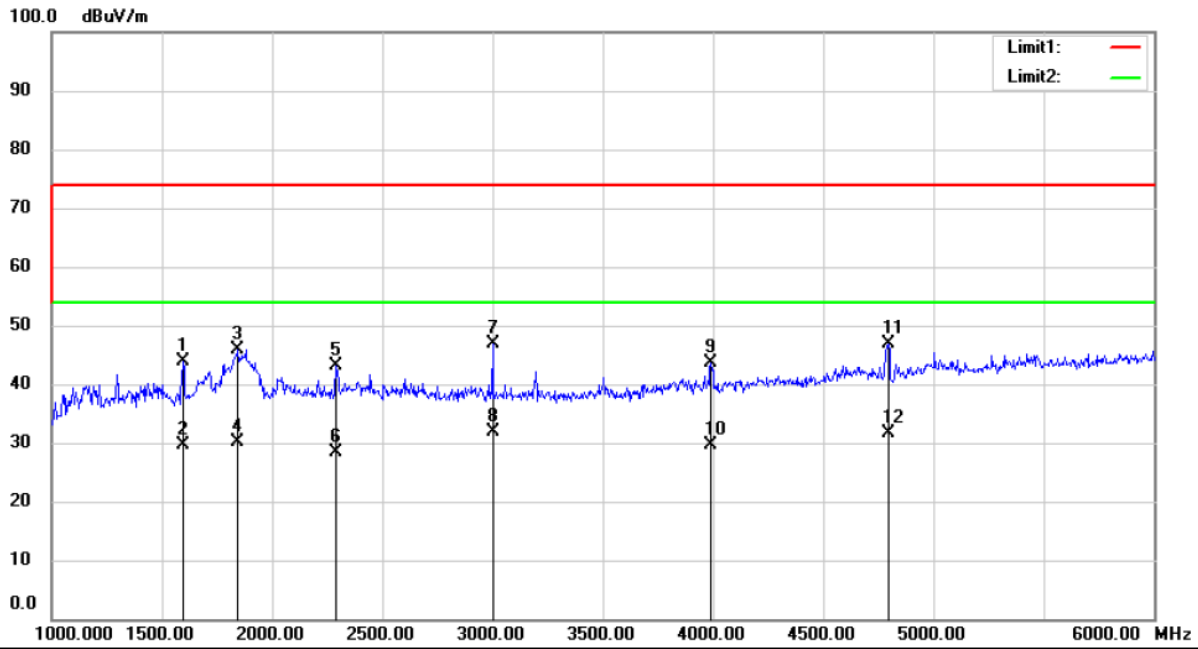

Site 3m Chamber #3

Polarization: **Horizontal**

Temperature: 24 C

Limit: (RE)FCC PART 15 CLASS B

Power: AC 120V/60Hz

Humidity: 53 %

Mode:HDD PLAY

Note:

No.	Mk.	Freq.	Reading Level	Correct Factor	Measurement	Limit	Over	Antenna Height	Table Degree	
		MHz	dBuV	dB	dBuV/m	dBuV/m	dB	cm	degree	Comment
1		1595.000	67.59	-23.61	43.98	74.00	-30.02			peak
2		1595.000	53.21	-23.61	29.60	54.00	-24.40			AVG
3		1845.000	69.52	-23.59	45.93	74.00	-28.07			peak
4		1845.000	53.69	-23.59	30.10	54.00	-23.90			AVG
5		2290.000	65.41	-22.32	43.09	74.00	-30.91			peak
6		2290.000	50.72	-22.32	28.40	54.00	-25.60			AVG
7		3000.000	68.56	-21.63	46.93	74.00	-27.07			peak
8	*	3000.000	53.63	-21.63	32.00	54.00	-22.00			AVG
9		3990.000	62.14	-18.61	43.53	74.00	-30.47			peak
10		3990.000	48.21	-18.61	29.60	54.00	-24.40			AVG
11		4795.000	62.49	-15.69	46.80	74.00	-27.20			peak
12		4795.000	47.39	-15.69	31.70	54.00	-22.30			AVG

*:Maximum data x:Over limit !:over margin

Operator: CSL

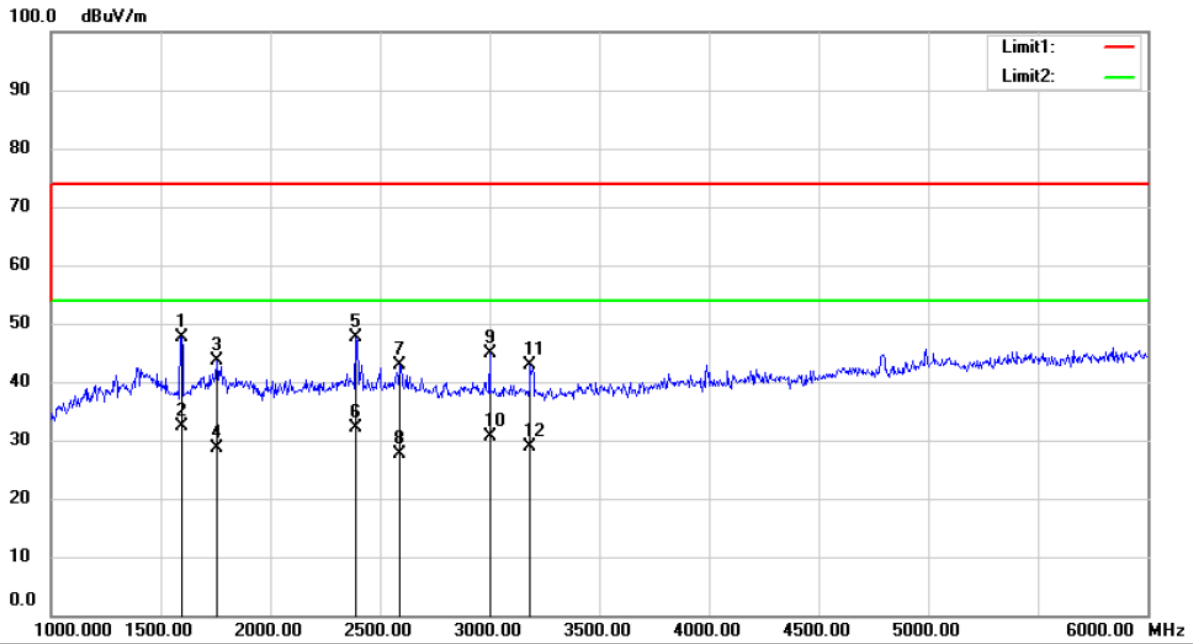

Site: 3m Chamber #3 Polarization: **Vertical** Temperature: 24 C
 Limit: (RE)FCC PART 15 CLASS B Power: AC 120V/60Hz Humidity: 53 %
 Mode:HDD PLAY
 Note:

No.	Mk.	Freq.	Reading Level	Correct Factor	Measurement	Limit	Over	Antenna Height	Table Degree	
		MHz	dBuV	dB	dBuV/m	dBuV/m	dB	cm	degree	Comment
1		1595.000	71.23	-23.61	47.62	74.00	-26.38			peak
2	*	1595.000	56.11	-23.61	32.50	54.00	-21.50			AVG
3		1755.000	67.38	-23.71	43.67	74.00	-30.33			peak
4		1755.000	52.31	-23.71	28.60	54.00	-25.40			AVG
5		2390.000	69.81	-22.07	47.74	74.00	-26.26			peak
6		2390.000	54.17	-22.07	32.10	54.00	-21.90			AVG
7		2590.000	64.69	-21.76	42.93	74.00	-31.07			peak
8		2590.000	49.36	-21.76	27.60	54.00	-26.40			AVG
9		3000.000	66.46	-21.63	44.83	74.00	-29.17			peak
10		3000.000	52.23	-21.63	30.60	54.00	-23.40			AVG
11		3185.000	64.15	-21.23	42.92	74.00	-31.08			peak
12		3185.000	50.13	-21.23	28.90	54.00	-25.10			AVG

*:Maximum data x:Over limit !:over margin

Operator: CSL

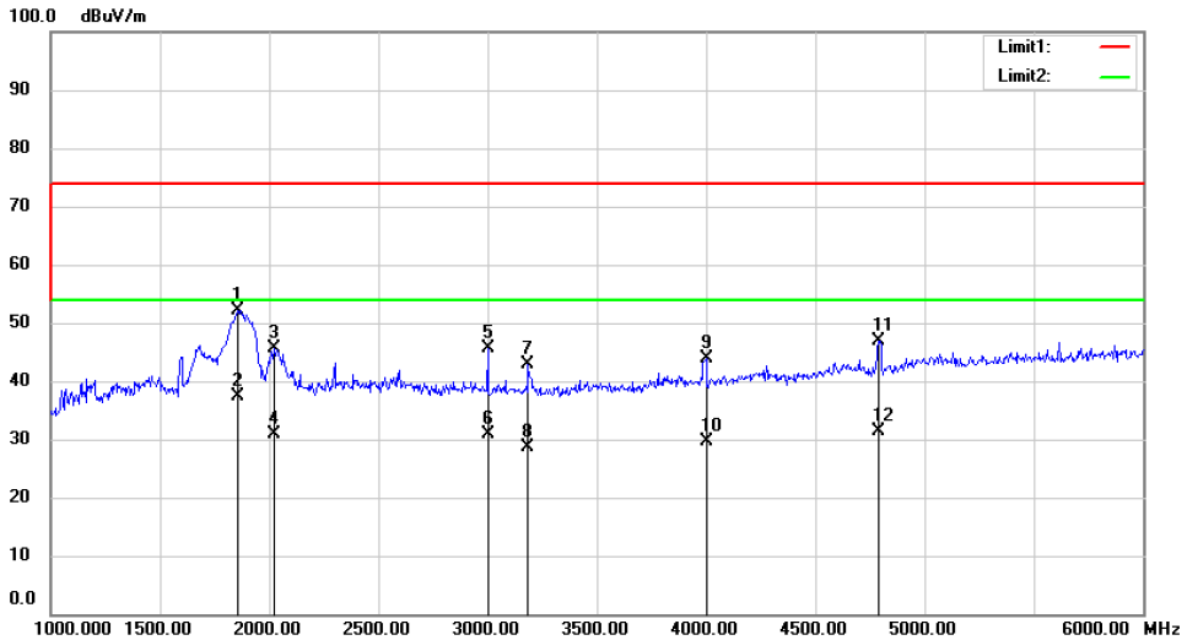

Site 3m Chamber #3 Polarization: **Horizontal** Temperature: 24 C
 Limit: (RE)FCC PART 15 CLASS B Power: AC 120V/60Hz Humidity: 53 %
 Mode:HDMI IN
 Note:

No.	Mk.	Freq.	Reading Level	Correct Factor	Measurement	Limit	Over	Antenna Height	Table Degree	
		MHz	dBuV	dB	dBuV/m	dBuV/m	dB	cm	degree	Comment
1		1855.000	75.71	-23.55	52.16	74.00	-21.84			peak
2	*	1855.000	60.95	-23.55	37.40	54.00	-16.60			AVG
3		2020.000	68.66	-23.01	45.65	74.00	-28.35			peak
4		2020.000	53.91	-23.01	30.90	54.00	-23.10			AVG
5		3000.000	67.20	-21.63	45.57	74.00	-28.43			peak
6		3000.000	52.43	-21.63	30.80	54.00	-23.20			AVG
7		3185.000	64.01	-21.23	42.78	74.00	-31.22			peak
8		3185.000	49.83	-21.23	28.60	54.00	-25.40			AVG
9		4000.000	62.48	-18.57	43.91	74.00	-30.09			peak
10		4000.000	48.17	-18.57	29.60	54.00	-24.40			AVG
11		4790.000	62.71	-15.72	46.99	74.00	-27.01			peak
12		4790.000	47.12	-15.72	31.40	54.00	-22.60			AVG

*:Maximum data x:Over limit !:over margin

Operator: CSL

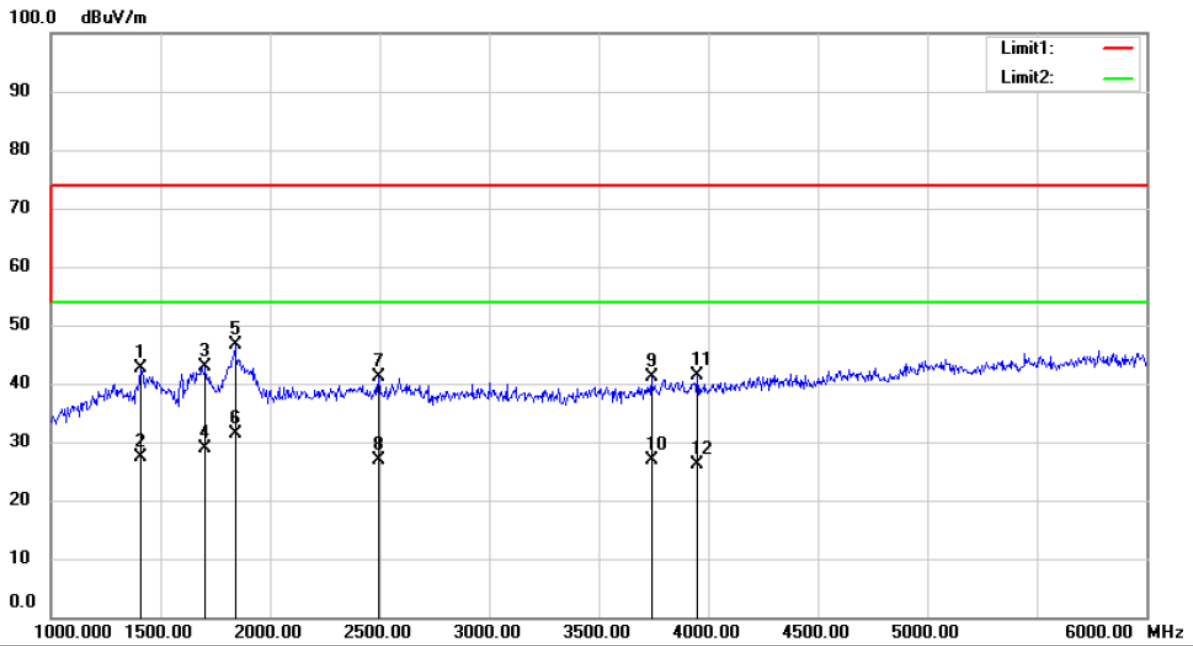

Site 3m Chamber #3 Polarization: **Vertical** Temperature: 24 C
 Limit: (RE)FCC PART 15 CLASS B Power: AC 120V/60Hz Humidity: 53 %
 Mode:HDMI IN
 Note:

No.	Mk.	Freq.	Reading Level	Correct Factor	Measurement	Limit	Over	Antenna Height	Table Degree	
		MHz	dBuV	dB	dBuV/m	dBuV/m	dB	cm	degree	Comment
1		1410.000	65.93	-23.21	42.72	74.00	-31.28			peak
2		1410.000	50.61	-23.21	27.40	54.00	-26.60			AVG
3		1705.000	66.47	-23.69	42.78	74.00	-31.22			peak
4		1705.000	52.59	-23.69	28.90	54.00	-25.10			AVG
5		1840.000	70.21	-23.60	46.61	74.00	-27.39			peak
6	*	1840.000	55.00	-23.60	31.40	54.00	-22.60			AVG
7		2495.000	62.83	-21.81	41.02	74.00	-32.98			peak
8		2495.000	48.61	-21.81	26.80	54.00	-27.20			AVG
9		3740.000	60.63	-19.60	41.03	74.00	-32.97			peak
10		3740.000	46.50	-19.60	26.90	54.00	-27.10			AVG
11		3950.000	60.17	-18.77	41.40	74.00	-32.60			peak
12		3950.000	44.87	-18.77	26.10	54.00	-27.90			AVG

*:Maximum data x:Over limit !:over margin

Operator: CSL

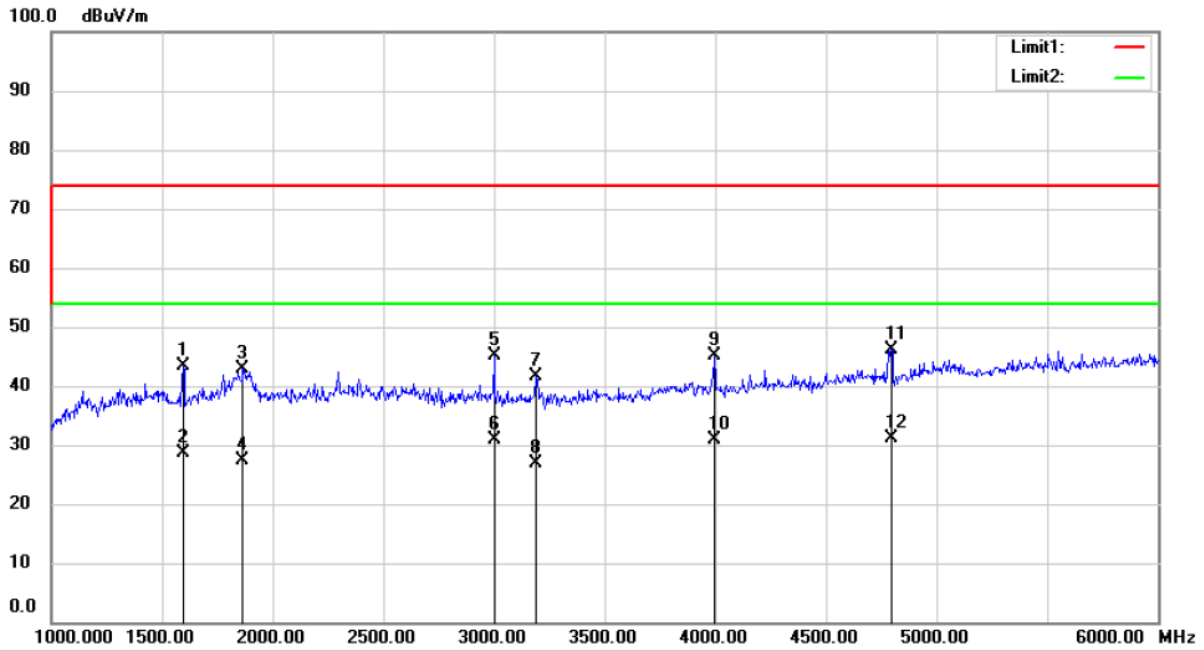

Site 3m Chamber #3 Polarization: **Horizontal** Temperature: 24 C
 Limit: (RE)FCC PART 15 CLASS B Power: AC 120V/60Hz Humidity: 53 %
 Mode:VGA IN
 Note:

No.	Mk.	Freq.	Reading Level	Correct Factor	Measurement	Limit	Over	Antenna Height	Table Degree	
		MHz	dBuV	dB	dBuV/m	dBuV/m	dB	cm	degree	Comment
1		1595.000	67.08	-23.61	43.47	74.00	-30.53			peak
2		1595.000	52.21	-23.61	28.60	54.00	-25.40			AVG
3		1865.000	66.41	-23.52	42.89	74.00	-31.11			peak
4		1865.000	50.92	-23.52	27.40	54.00	-26.60			AVG
5		3000.000	66.77	-21.63	45.14	74.00	-28.86			peak
6		3000.000	52.53	-21.63	30.90	54.00	-23.10			AVG
7		3190.000	62.91	-21.23	41.68	74.00	-32.32			peak
8		3190.000	48.03	-21.23	26.80	54.00	-27.20			AVG
9		3995.000	63.66	-18.58	45.08	74.00	-28.92			peak
10		3995.000	49.38	-18.58	30.80	54.00	-23.20			AVG
11		4795.000	61.83	-15.69	46.14	74.00	-27.86			peak
12	*	4795.000	46.89	-15.69	31.20	54.00	-22.80			AVG

*:Maximum data x:Over limit !:over margin

Operator: CSL

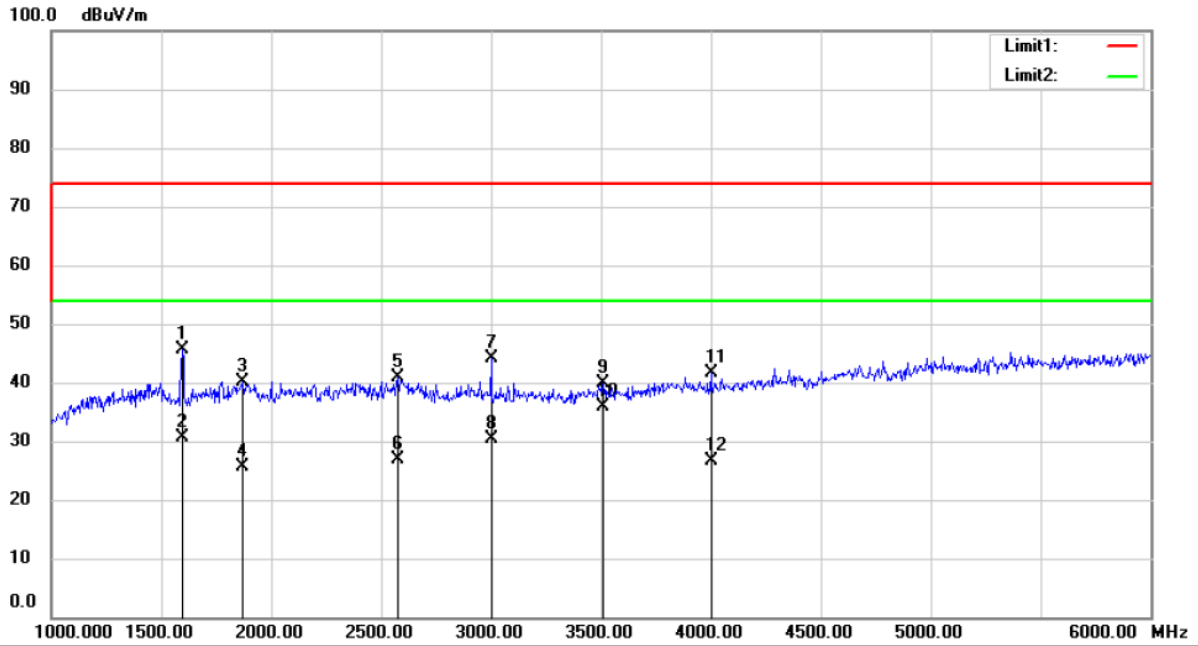

Site 3m Chamber #3 Polarization: **Vertical** Temperature: 24 C
 Limit: (RE)FCC PART 15 CLASS B Power: AC 120V/60Hz Humidity: 53 %
 Mode:VGA IN
 Note:

No.	Mk.	Freq.	Reading	Correct	Measure-	Limit	Over	Antenna	Table	
		MHz	Level	Factor	ment			Height	Degree	Comment
			dBuV	dB	dBuV/m	dBuV/m	dB	cm	degree	
1		1595.000	69.29	-23.61	45.68	74.00	-28.32			peak
2		1595.000	54.21	-23.61	30.60	54.00	-23.40			AVG
3		1870.000	63.72	-23.50	40.22	74.00	-33.78			peak
4		1870.000	49.20	-23.50	25.70	54.00	-28.30			AVG
5		2575.000	62.58	-21.77	40.81	74.00	-33.19			peak
6		2575.000	48.67	-21.77	26.90	54.00	-27.10			AVG
7		3000.000	65.82	-21.63	44.19	74.00	-29.81			peak
8		3000.000	52.03	-21.63	30.40	54.00	-23.60			AVG
9		3510.000	60.30	-20.52	39.78	74.00	-34.22			peak
10	*	3510.000	56.32	-20.52	35.80	54.00	-18.20			AVG
11		4000.000	60.08	-18.57	41.51	74.00	-32.49			peak
12		4000.000	45.27	-18.57	26.70	54.00	-27.30			AVG

*:Maximum data x:Over limit !:over margin

Operator: CSL

6. PHOTOGRAPHS

6.1. Photos of Conducted Emission Measurement



6.2. Photos of Radiation Emission Measurement

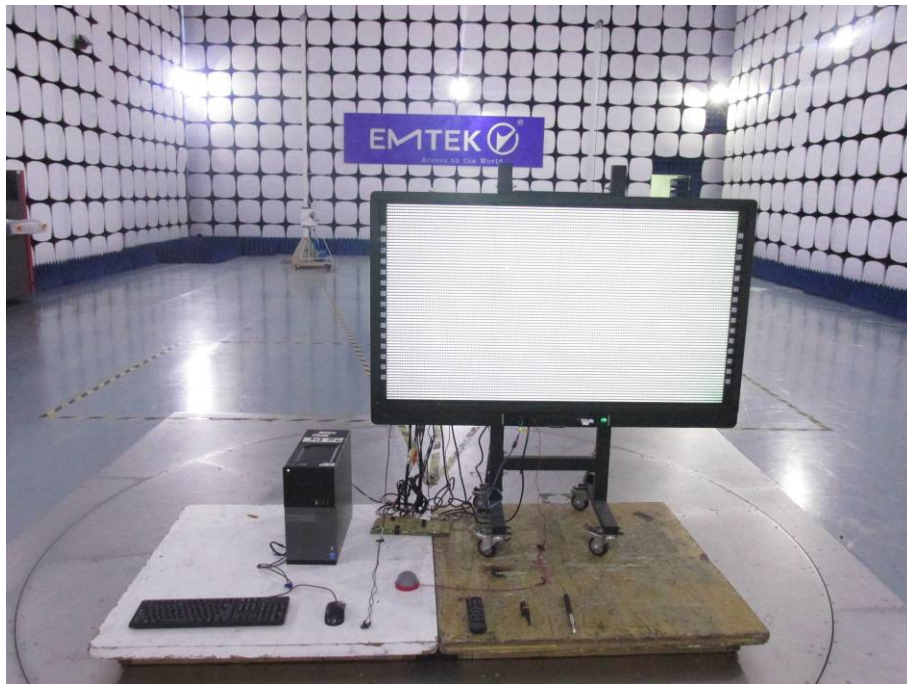

APPENDIX
(Photos of EUT)







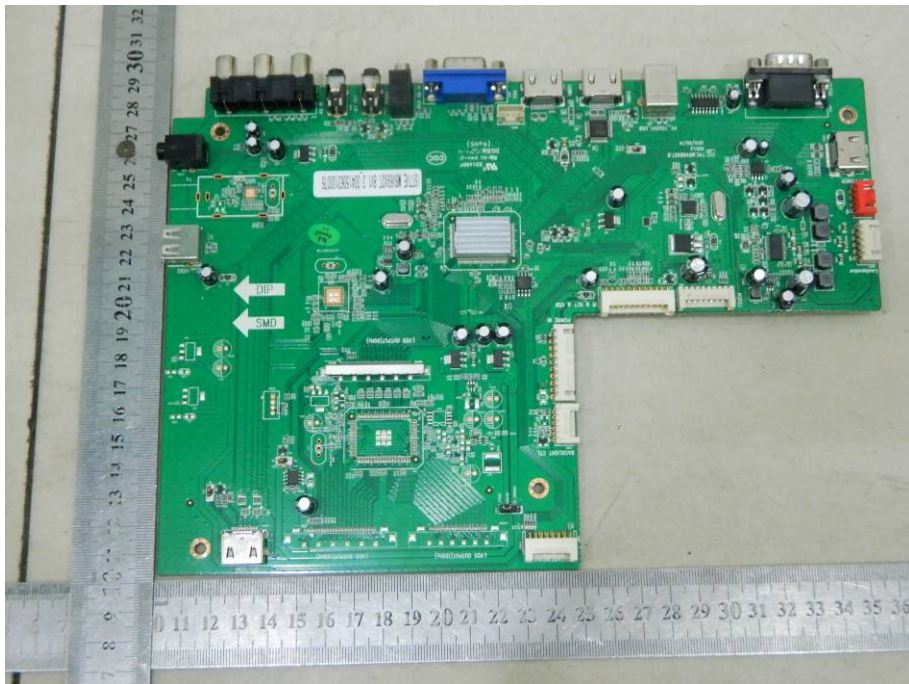

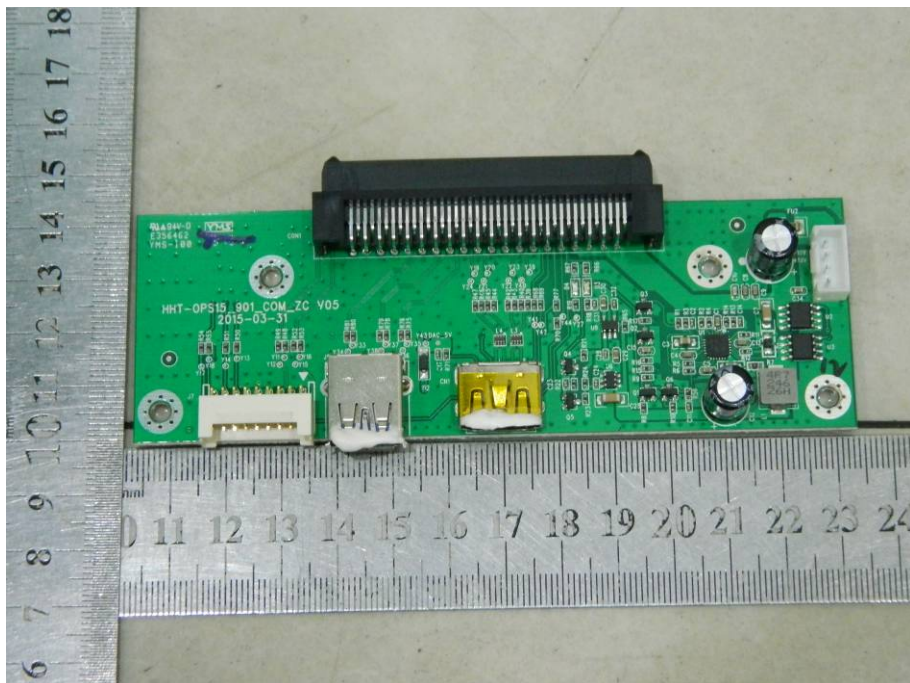
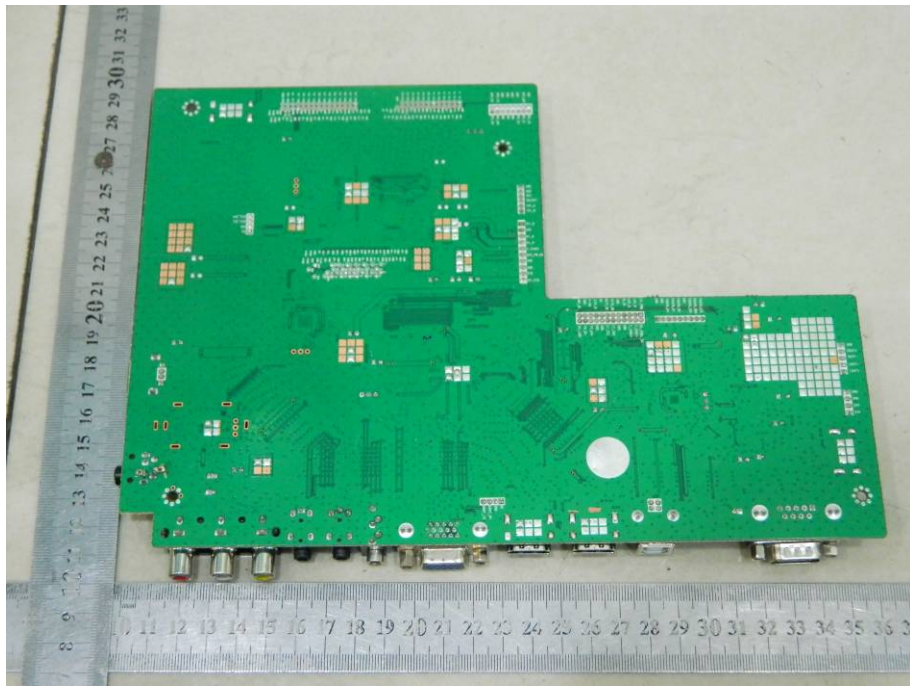

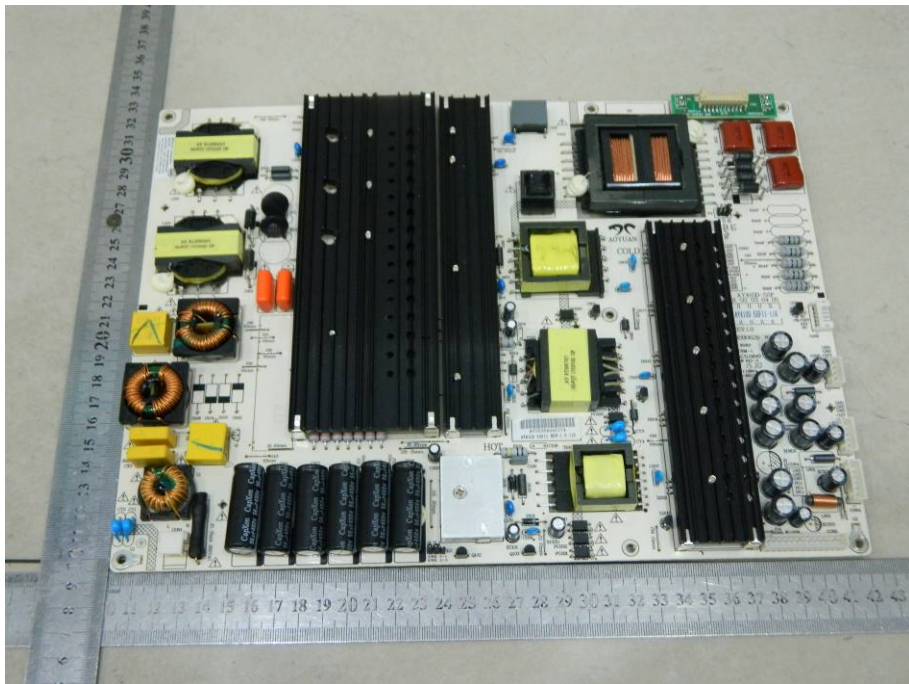
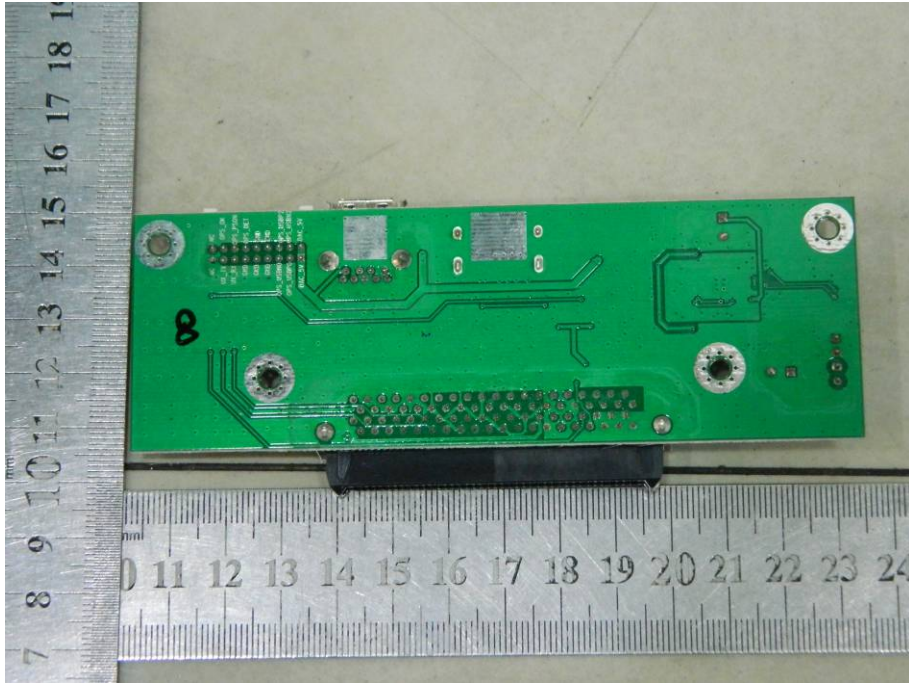

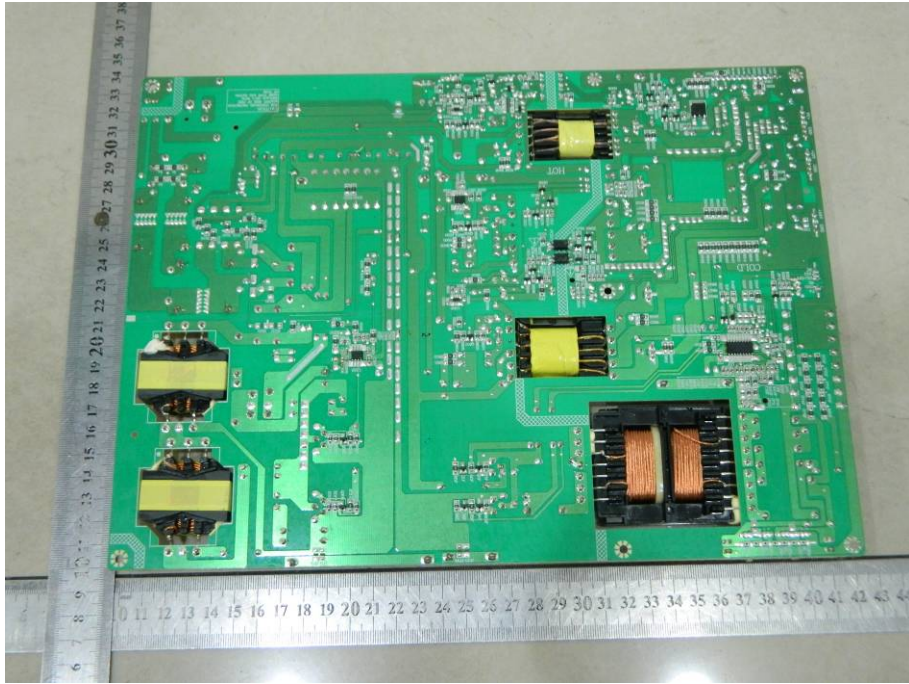

-----The end-----