

FCC 47 CFR PART 15 SUBPART B

CERTIFICATION TEST REPORT

For

SHENZHEN Hitevision Technology Co., Ltd.

Interactive Touch Screen, LED Interactive Multi-Touch Display, Optimus-Touch Screen, Genee Touch, Interactive Led Monitor, Touch Pro

Model No.: TWB-IB70, TWB-IB70X, TWB-IB70A, TWB-IB70AX, VI-70X1, 70G-Touch Slim-DELX, QIT1270 10BA, TT-7015B, TT-7015BX, TT-701XB, Predia PRO OTS-70V3/15S, We-Touch 70-10T, TWB-IBC70, TWB-IBC70X, TWB-IBC70A, TWB-IBC70AX, P-70Da, HD-I5XXXE, HD-IXXXE, WS-Z5XXX('X'=0-9 or A-Z)

FCC ID: 2ACYT-AHH15901-70

Prepared for : SHENZHEN Hitevision Technology Co., Ltd.
Address : No. 8, Qinglan 1st Road, Pingshan, Shenzhen, Guangdong 518118, P. R. China

Prepared by : EMTEK (SHENZHEN) CO., LTD.
Address : Bldg 69, Majialong Industry Zone, Nanshan District, Shenzhen, Guangdong, China

Tel: (0755) 26954280
Fax: (0755) 26954282

Report Number : ES150917006E
Date of Test : September 17, 2015 to October 19, 2015
Date of Report : October 19, 2015

TABLE OF CONTENT

Test Report Description	Page
1. SUMMARY OF TEST RESULT	5
2. GENERAL INFORMATION	6
2.1. Description of Device (EUT).....	6
2.2. Description of Test Facility.....	7
2.3. Description of Support Device.....	7
2.4. Measurement Uncertainty	7
3. MEASURING DEVICE AND TEST EQUIPMENT	8
3.1. For Power Line Conducted Emission Measurement.....	8
3.2. For Radiated Emission Measurement (10m Chamber).....	8
3.3. For Radiated Emission Measurement (3m Chamber).....	8
4. POWER LINE CONDUCTED EMISSION MEASUREMENT	9
4.1. Block Diagram of Test Setup	9
4.2. Measuring Standard	9
4.3. Power Line Conducted Emission Limits (Class B)	9
4.4. EUT Configuration on Measurement.....	9
4.5. Operating Condition of EUT	9
4.6. Test Procedure	10
4.7. Measuring Results.....	10
5. RADIATED EMISSION MEASUREMENT.....	15
5.1. Block Diagram of Test Setup	15
5.2. Measuring Standard	16
5.3. Radiated Emission Limits (Class B)	16
5.4. EUT Configuration on Measurement.....	16
5.5. Operating Condition of EUT	16
5.6. Test Procedure	16
5.7. Measuring Results.....	17

TEST REPORT DESCRIPTION

Applicant : SHENZHEN Hitevision Technology Co., Ltd.

Manufacturer : SHENZHEN Hitevision Technology Co., Ltd.

Trademark :



EUT : Interactive Touch Screen, LED Interactive Multi-Touch Display, Optimus-Touch Screen, Genee Touch, Interactive Led Monitor, Touch Pro

Model No. : TWB-IB70, TWB-IB70X, TWB-IB70A, TWB-IB70AX, VI-70X1, 70G-Touch Slim-DELX, QIT1270 10BA, TT-7015B, TT-7015BX, TT-701XB, Predia PRO OTS-70V3/15S, We-Touch 70-10T, TWB-IBC70, TWB-IBC70X, TWB-IBC70A, TWB-IBC70AX, P-70Da, HD-I5XXXE, HD-IXXXE, WS-Z5XXX('X'=0-9 or A-Z)

Power Supply : AC 100-240V ~50/60Hz Max 2.5A

Measurement Procedure Used:

FCC Rules and Regulations Part 15 : 2015 Subpart B Class B & FCC / ANSI C63.4-2014

The device described above is tested by EMTEK (SHENZHEN) CO., LTD. to determine the maximum emission levels emanating from the device and the severe levels of the device can endure and its performance criterion. The measurement results are contained in this test report and EMTEK (SHENZHEN) CO., LTD. is assumed full of responsibility for the accuracy and completeness of these measurements. Also, this report shows that the EUT (Equipment Under Test) is technically compliant with the FCC requirements.

This report applies to above tested sample only and shall not be reproduced in part without written approval of EMTEK (SHENZHEN) CO., LTD.

Date of Test : September 17, 2015 to October 19, 2015

Prepared by :

A handwritten signature in black ink that reads 'Joe Xia'.

Joe Xia /Editor

Reviewer :

A handwritten signature in black ink that reads 'Jack Li'.

Jack Li /Supervisor

Approve & Authorized Signer :

A handwritten signature in black ink that reads 'Lisa Wang'.

Lisa Wang /Manager

Modified Information

Version	Report No.	Revision Date	Summary
Ver.1.0	ES150917006E	/	Original Report

1. SUMMARY OF TEST RESULT

EMISSION		
Description of Test Item	Standard & Limits	Results
Conducted Disturbance at Mains Terminals	FCC Part 15, Subpart B, Class B ANSI C63.4: 2014	Pass
Radiated Disturbance	FCC Part 15, Subpart B, Class B ANSI C63.4: 2014	Pass
Note: N/A is an abbreviation for Not Applicable.		

2. GENERAL INFORMATION

2.1. Description of Device (EUT)

EUT	:	Interactive Touch Screen, LED Interactive Multi-Touch Display, Optimus-Touch Screen, Genee Touch, Interactive Led Monitor, Touch Pro
Model Number	:	TWB-IB70, TWB-IB70X, TWB-IB70A, TWB-IB70AX, VI-70X1, 70G-Touch Slim-DELX, QIT1270 10BA, TT-7015B, TT-7015BX, TT-701XB, Predia PRO OTS-70V3/15S, We-Touch 70-10T, TWB-IBC70, TWB-IBC70X, TWB-IBC70A, TWB-IBC70AX, P-70Da, HD-I5XXXE, HD-IXXXXE, WS-Z5XXX('X'=0-9 or A-Z) (Note: These models are identical in circuitry and electrical, mechanical and physical construction; the only difference is the model number. for trading purpose. We prepare TWB-IB70 for all test.)
Applicant	:	SHENZHEN Hitevision Technology Co., Ltd.
Address	:	No. 8, Qinglan 1st Road, Pingshan, Shenzhen, Guangdong 518118, P. R. China
Manufacturer	:	SHENZHEN Hitevision Technology Co., Ltd.
Address	:	No. 8, Qinglan 1st Road, Pingshan, Shenzhen, Guangdong 518118, P. R. China
Date of Received	:	September 17, 2015
Date of Test	:	September 17, 2015 to October 19, 2015

2.2. Description of Test Facility

Site Description	
EMC Lab.	<ul style="list-style-type: none"> : Accredited by CNAS, 2013.10.29 The certificate is valid until 2016.10.28 The Laboratory has been assessed and proved to be in compliance with CNAS-CL01: 2006(identical to ISO/IEC17025: 2005) The Certificate Registration Number is L2291 : Accredited by TUV Rheinland Shenzhen, 2010.5.25 The Laboratory has been assessed according to the requirements ISO/IEC 17025. : Accredited by FCC, July 24, 2013 The Certificate Registration Number is 406365. : Accredited by FCC, April 17, 2013 The Certificate Registration Number is 709623. : Accredited by Industry Canada, November 29, 2012 The Certificate Registration Number is 4480A

2.3. Description of Support Device

PC	: Manufacturer: LENOVO M/N: 9702 S/N: L3C4410 CE, FCC: DOC
LCD TV	: Manufacturer: SONY M/N: KDL-24EX520 S/N: 6258850 CE , FCC,
Keyboard	: Manufacturer: LENOVO M/N: KU-0225 S/N:0585494 CE, FCC: DOC
Mouse	: Manufacturer: LENOVO M/N: MO28UOL S/N:44G7862 068 CE, FCC: DOC

2.4. Measurement Uncertainty

Test Item	Uncertainty
Conducted Emission Uncertainty	: 2.96dB(9k~150kHz Conduction 1#) 2.74dB(150k-30MHz Conduction 1#)
Radiated Emission Uncertainty (10m Chamber)	: 3.96dB (30M~1GHz Polarize: H) 4.04dB (30M~1GHz Polarize: V)
Radiated Emission Uncertainty (3m Chamber)	: 4.46dB (1~6GHz)

3. MEASURING DEVICE AND TEST EQUIPMENT

3.1. For Power Line Conducted Emission Measurement

Item	Equipment	Manufacturer	Model No.	Serial No.	Last Cal.	Cal. Interval
<input checked="" type="checkbox"/>	Test Receiver	Rohde & Schwarz	ESCI	26115-010-002 7	May 16, 2015	1 Year
<input checked="" type="checkbox"/>	L.I.S.N.	Rohde & Schwarz	ENV216	101161	May 16, 2015	1 Year
<input checked="" type="checkbox"/>	50Ω Coaxial Switch	Anritsu	MP59B	6100175589	May 16, 2015	1 Year
<input checked="" type="checkbox"/>	Voltage Probe	Rohde & Schwarz	ESH2-Z3	100122	May 16, 2015	1 Year

3.2. For Radiated Emission Measurement (10m Chamber)

Item	Equipment	Manufacturer	Model No.	Serial No.	Last Cal.	Cal. Interval
<input checked="" type="checkbox"/>	EMI Test Receiver	Rohde & Schwarz	ESR3	1316.3003K03- 101706-HN	May 16, 2015	1 Year
<input checked="" type="checkbox"/>	EMI Test Receiver	Rohde & Schwarz	ESR3	1316.3003K03- 101707-Z1	May 16, 2015	1 Year
<input checked="" type="checkbox"/>	Pre-Amplifier	Lunar EM	LNA10M1G-40	J10111309120 01	May 16, 2015	1 Year
<input checked="" type="checkbox"/>	Pre-Amplifier	Lunar EM	LNA10M1G-40	J10111311260 02	May 16, 2015	1 Year
<input checked="" type="checkbox"/>	Bilog Antenna	Schwarzbeck	VULB9163	659	May 16, 2015	1 Year
<input checked="" type="checkbox"/>	Bilog Antenna	Schwarzbeck	VULB9163	661	May 16, 2015	1 Year

3.3. For Radiated Emission Measurement (3m Chamber)

Item	Equipment	Manufacturer	Model No.	Serial No.	Last Cal.	Cal. Interval
<input checked="" type="checkbox"/>	EMI Test Receiver	Rohde & Schwarz	ESU	1302.6005.26	May 16, 2015	1 Year
<input checked="" type="checkbox"/>	Pre-Amplifier	A.H.	PAM-0126	1415261	May 16, 2015	1 Year
<input checked="" type="checkbox"/>	Horn Antenna	Schwarzbeck	BBHA 9120	707	May 16, 2015	1 Year

4. POWER LINE CONDUCTED EMISSION MEASUREMENT

4.1. Block Diagram of Test Setup

For Connect to PC:

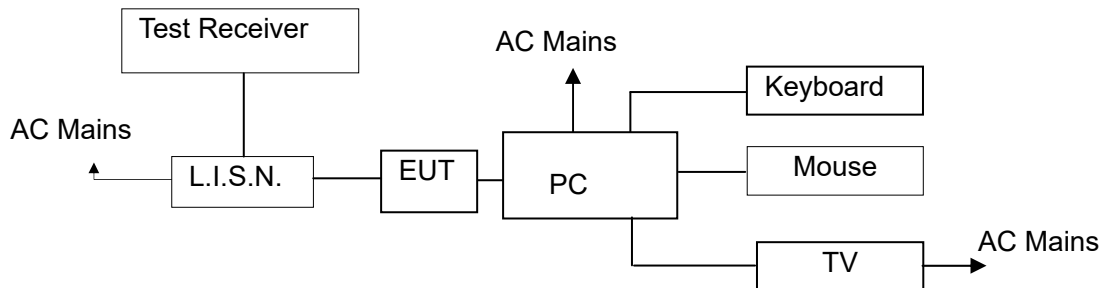

(EUT: Interactive Touch Screen)

4.2. Measuring Standard

FCC Part 15, Subpart B, Class B ANSI C63.4: 2014

4.3. Power Line Conducted Emission Limits (Class B)

Frequency (MHz)	Limit (dB μ V)	
	Quasi-peak Level	Average Level
0.15 ~ 0.50	66.0 ~ 56.0 *	56.0 ~ 46.0 *
0.50 ~ 5.00	56.0	46.0
5.00 ~ 30.00	60.0	50.0

NOTE1-The lower limit shall apply at the transition frequencies.
NOTE2-The limit decreases linearly with the logarithm of the frequency in the range 0.15MHz to 0.50MHz.

4.4. EUT Configuration on Measurement

The following equipments are installed on Conducted Emission Measurement to meet FCC requirements and operating in a manner which tends to maximize its emission characteristics in a normal application.

EUT : Interactive Touch Screen
Model Number : TWB-IB70

4.5. Operating Condition of EUT

4.5.1. Setup the EUT as shown on Section 4.1.

4.5.2. Turn on the power of all equipments.

4.5.3. Let the EUT work in measuring mode (AV in, Y+Pb+Pr in, HDMI in, USB Play, SD CARD play, VGA & Ping) and measure it.

4.6. Test Procedure

The EUT is put on the plane 0.1m high above the ground by insulating support and connected to the AC mains through Line Impedance Stability Network (L.I.S.N). This provided a 50ohm coupling impedance for the tested equipments. Both sides of AC line are investigated to find out the maximum conducted emission according to the FCC regulations during conducted emission measurement.

The bandwidth of the field strength meter (R&S Test Receiver ESCS30) is set at 9kHz in 150kHz~30MHz and 200Hz in 9kHz~150kHz.

The frequency range from 150kHz to 30MHz is investigated.

All the modes were tested and the data of the worst modes (VGA(1920*1080) & Ping) are attached the following pages.

4.7. Measuring Results

PASS.

Please refer to the following pages.

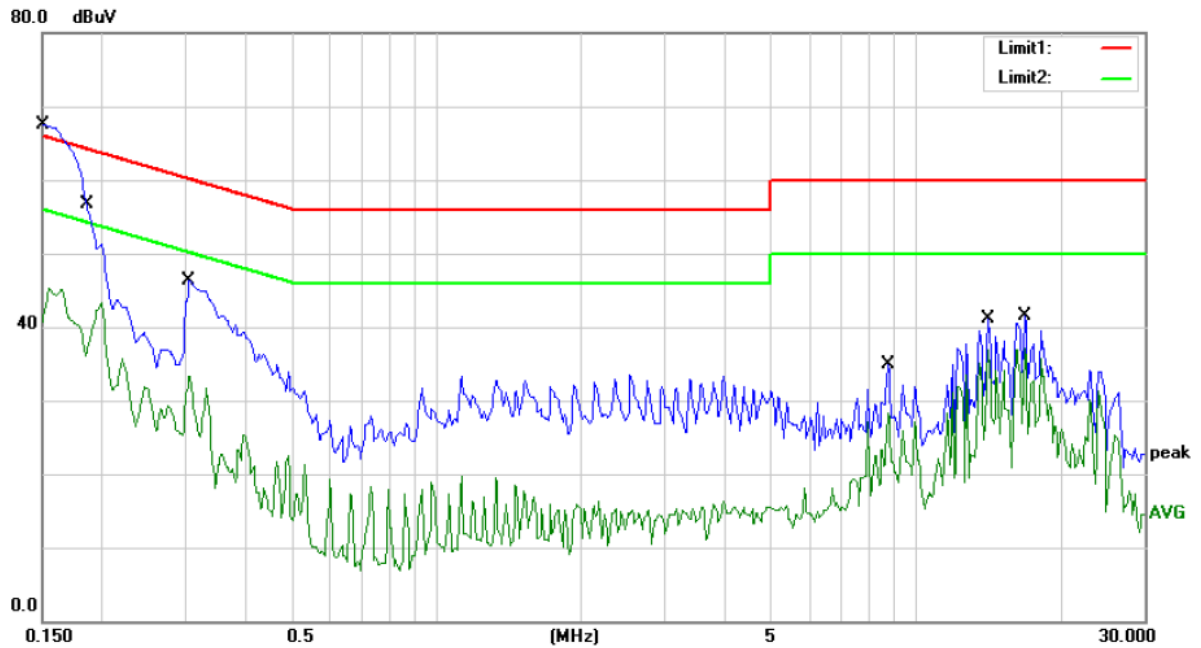

Site Conduction #1

Phase: **L1**

Temperature: 22

Limit: (CE)FCC PART 15 class B_QP

Power: AC 120V/60Hz

Humidity: 50 %

EUT: Interactive Touch Screen

M/N: TWB-IB70

Mode: VGA(1920*1080)+PING

Note:

No.	Mk.	Freq.	Reading Level	Correct Factor	Measurement	Limit	Over	Detector	Comment
		MHz	dBuV	dB	dBuV	dBuV	dB		
1	*	0.1500	63.00	0.00	63.00	66.00	-3.00	QP	
2		0.1500	45.24	0.00	45.24	56.00	-10.76	AVG	
3		0.1874	55.67	0.00	55.67	64.15	-8.48	QP	
4		0.1874	43.30	0.00	43.30	54.15	-10.85	AVG	
5		0.3050	46.25	0.00	46.25	60.11	-13.86	QP	
6		0.3050	33.30	0.00	33.30	50.11	-16.81	AVG	
7		8.7600	34.98	0.00	34.98	60.00	-25.02	QP	
8		8.7600	28.36	0.00	28.36	50.00	-21.64	AVG	
9		14.1500	41.19	0.00	41.19	60.00	-18.81	QP	
10		14.1500	36.82	0.00	36.82	50.00	-13.18	AVG	
11		16.9000	41.43	0.00	41.43	60.00	-18.57	QP	
12		16.9000	37.19	0.00	37.19	50.00	-12.81	AVG	

*:Maximum data x:Over limit !:over margin Comment: Factor build in receiver. Operator: WAP

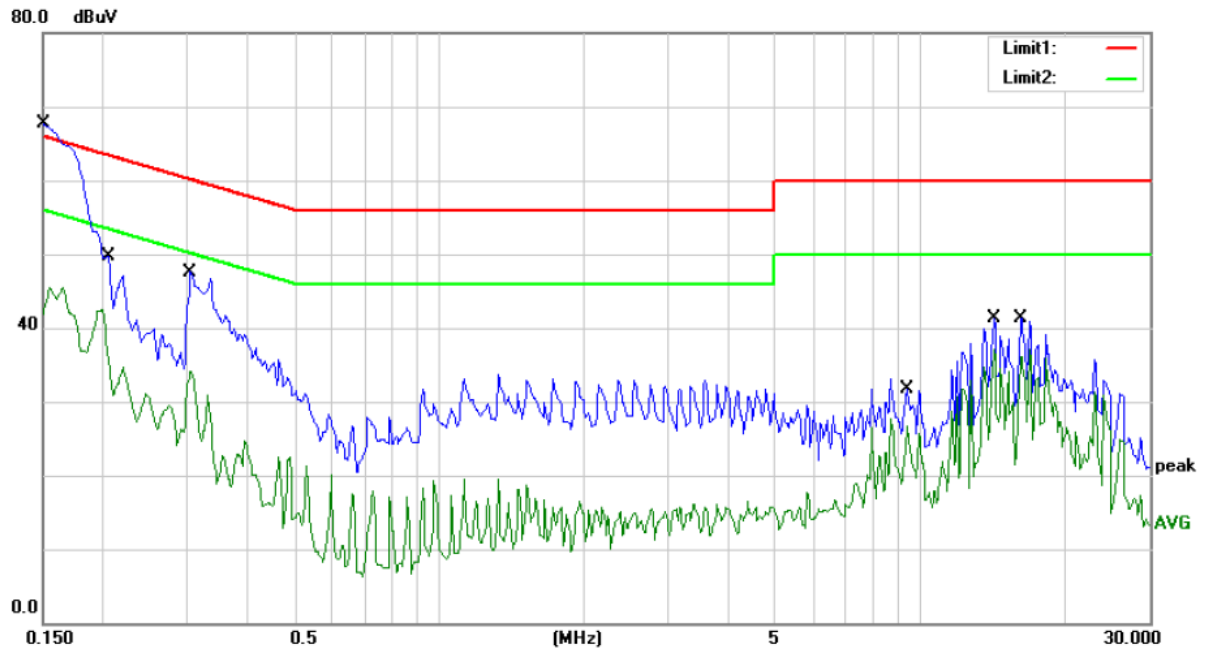

Site Conduction #1

Phase: **N**

Temperature: 22

Limit: (CE)FCC PART 15 class B_QP

Power: AC 120V/60Hz

Humidity: 50 %

EUT: Interactive Touch Screen

M/N: TWB-IB70

Mode: VGA(1920*1080)+PING

Note:

No.	Mk.	Freq.	Reading Level	Correct Factor	Measurement	Limit	Over	Detector	Comment
		MHz	dBuV	dB	dBuV	dBuV	dB		
1	*	0.1500	63.00	0.00	63.00	66.00	-3.00	QP	
2		0.1500	45.46	0.00	45.46	56.00	-10.54	AVG	
3		0.2050	49.64	0.00	49.64	63.41	-13.77	QP	
4		0.2050	42.49	0.00	42.49	53.41	-10.92	AVG	
5		0.3050	47.60	0.00	47.60	60.11	-12.51	QP	
6		0.3050	34.09	0.00	34.09	50.11	-16.02	AVG	
7		9.3900	31.75	0.00	31.75	60.00	-28.25	QP	
8		9.3900	27.78	0.00	27.78	50.00	-22.22	AVG	
9		14.2750	41.27	0.00	41.27	60.00	-18.73	QP	
10		14.2750	37.12	0.00	37.12	50.00	-12.88	AVG	
11		16.2250	41.40	0.00	41.40	60.00	-18.60	QP	
12		16.2250	37.13	0.00	37.13	50.00	-12.87	AVG	

*:Maximum data x:Over limit !:over margin Comment: Factor build in receiver. Operator: WAP

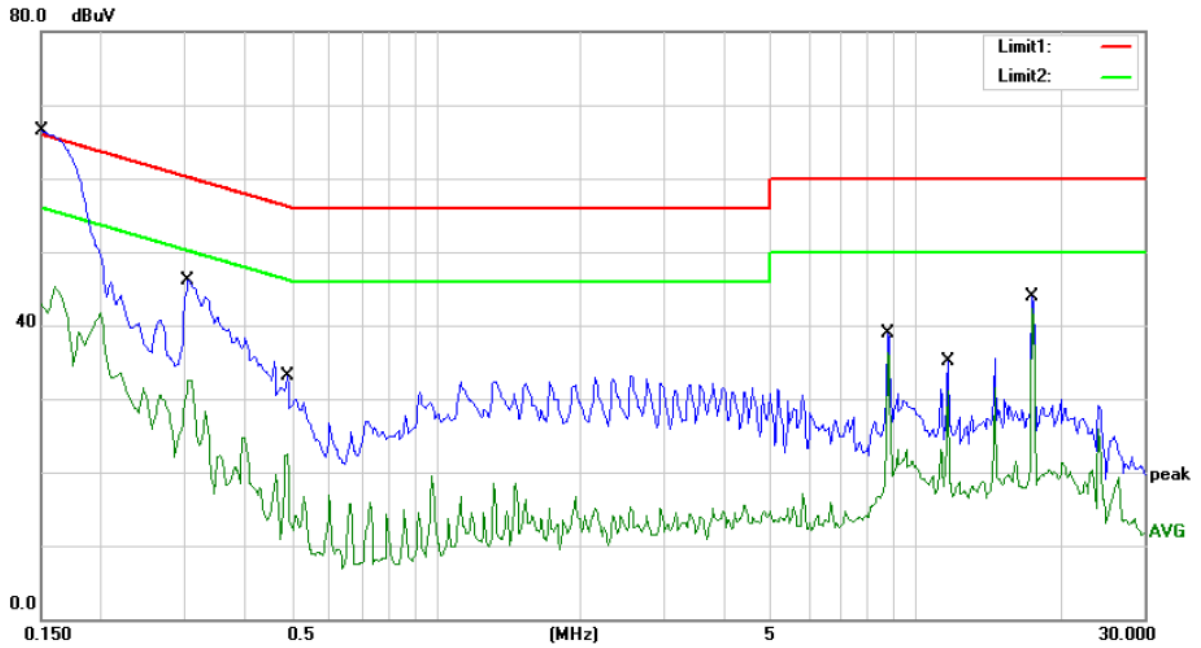

Site Conduction #1 Phase: **L1** Temperature: 22
 Limit: (CE)FCC PART 15 class B_QP Power: AC 240V/50Hz Humidity: 50 %
 EUT: Interactive Touch Screen
 M/N: TWB-IB70
 Mode: VGA(1920*1080)+PING
 Note:

No.	Mk.	Freq.	Reading Level	Correct Factor	Measurement	Limit	Over	Detector	Comment
		MHz	dBuV	dB	dBuV	dBuV	dB		
1	*	0.1500	61.00	0.00	61.00	66.00	-5.00	QP	
2		0.1500	45.32	0.00	45.32	56.00	-10.68	AVG	
3		0.3050	46.19	0.00	46.19	60.11	-13.92	QP	
4		0.3050	32.55	0.00	32.55	50.11	-17.56	AVG	
5		0.4900	33.13	0.00	33.13	56.17	-23.04	QP	
6		0.4900	22.50	0.00	22.50	46.17	-23.67	AVG	
7		8.7700	38.84	0.00	38.84	60.00	-21.16	QP	
8		8.7700	36.32	0.00	36.32	50.00	-13.68	AVG	
9		11.7000	35.16	0.00	35.16	60.00	-24.84	QP	
10		11.7000	31.06	0.00	31.06	50.00	-18.94	AVG	
11		17.5500	43.83	0.00	43.83	60.00	-16.17	QP	
12		17.5500	42.27	0.00	42.27	50.00	-7.73	AVG	

*:Maximum data x:Over limit !:over margin Comment: Factor build in receiver. Operator: WAP

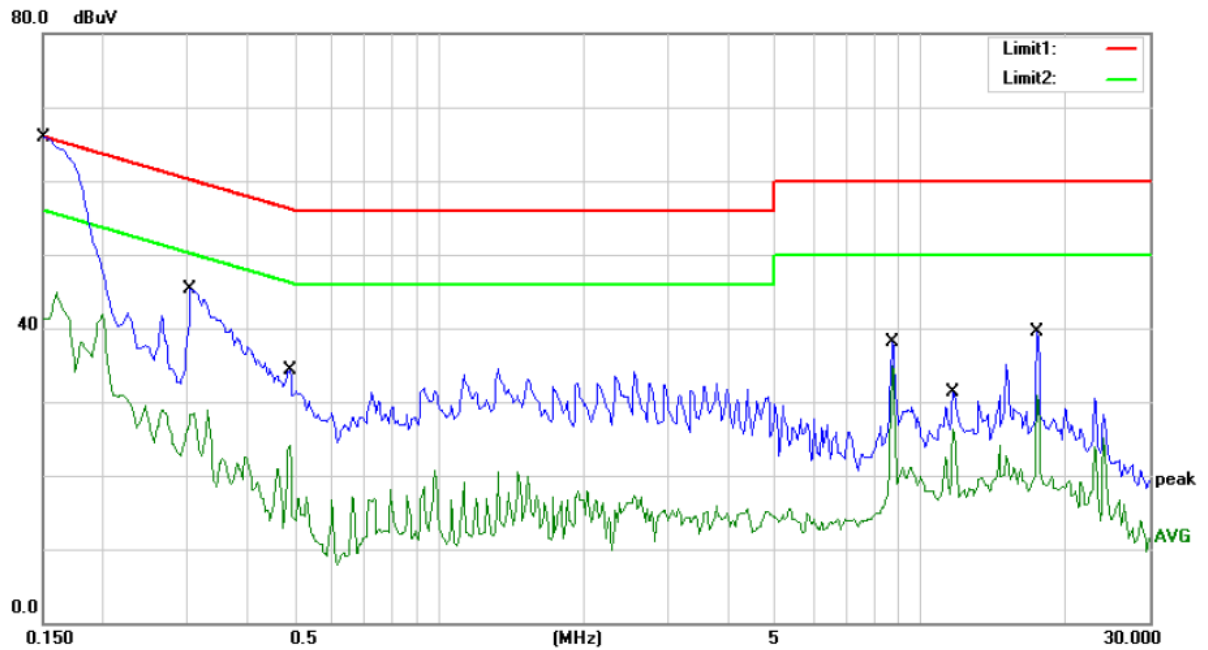

Site Conduction #1 Phase: **N** Temperature: 22
 Limit: (CE)FCC PART 15 class B_QP Power: AC 240V/50Hz Humidity: 50 %
 EUT: Interactive Touch Screen
 M/N: TWB-IB70
 Mode: VGA(1920*1080)+PING
 Note:

No.	Mk.	Freq.	Reading Level	Correct Factor	Measurement	Limit	Over	Detector	Comment
		MHz	dBuV	dB	dBuV	dBuV	dB		
1	*	0.1500	61.00	0.00	61.00	66.00	-5.00	QP	
2		0.1500	44.87	0.00	44.87	56.00	-11.13	AVG	
3		0.3050	45.25	0.00	45.25	60.11	-14.86	QP	
4		0.3050	28.96	0.00	28.96	50.11	-21.15	AVG	
5		0.4900	34.35	0.00	34.35	56.17	-21.82	QP	
6		0.4900	24.12	0.00	24.12	46.17	-22.05	AVG	
7		8.7700	38.05	0.00	38.05	60.00	-21.95	QP	
8		8.7700	34.90	0.00	34.90	50.00	-15.10	AVG	
9		11.7250	31.32	0.00	31.32	60.00	-28.68	QP	
10		11.7250	26.35	0.00	26.35	50.00	-23.65	AVG	
11		17.5500	39.48	0.00	39.48	60.00	-20.52	QP	
12		17.5500	30.82	0.00	30.82	50.00	-19.18	AVG	

*:Maximum data x:Over limit !:over margin Comment: Factor build in receiver. Operator: WAP

5. RADIATED EMISSION MEASUREMENT

5.1. Block Diagram of Test Setup

5.1.1. Block diagram of EUT System

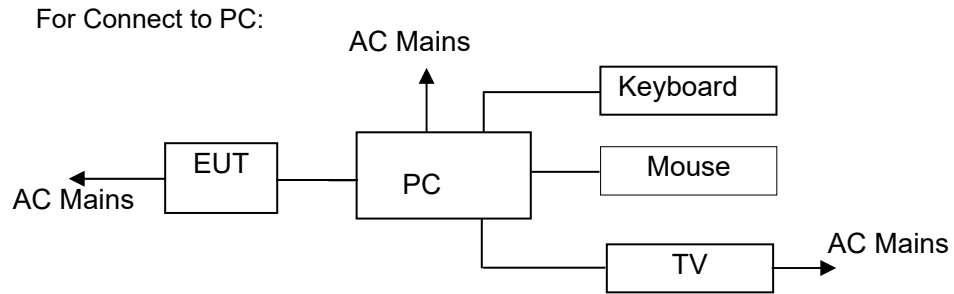

(EUT: Interactive Touch Screen)

5.1.2. Block diagram of test setup (In chamber)

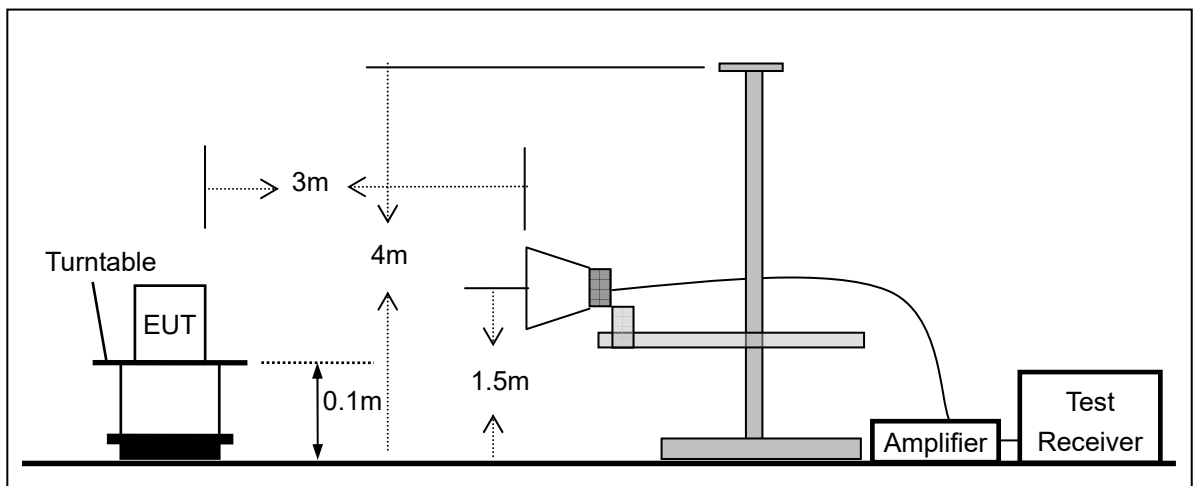
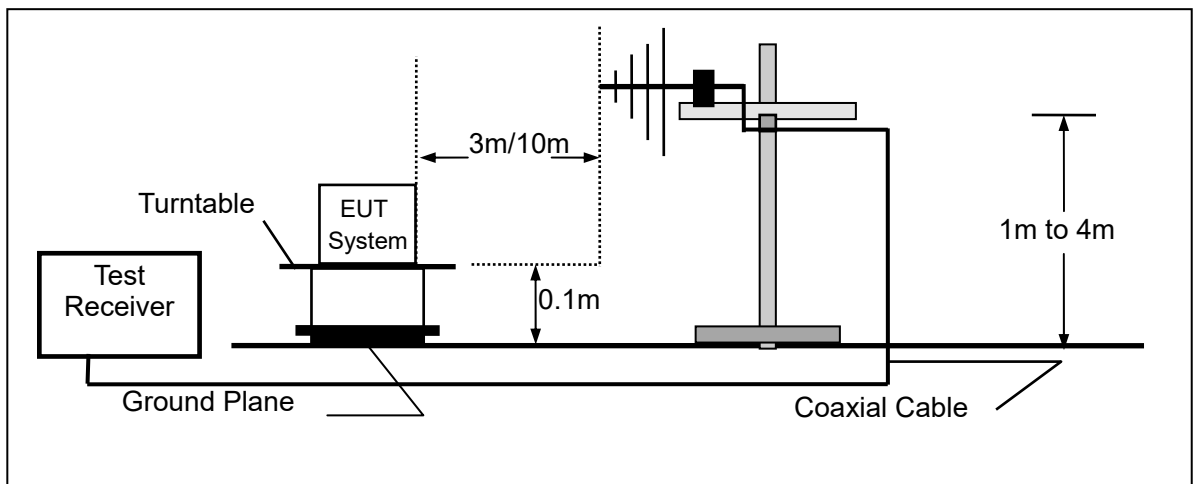

(EUT: Interactive Touch Screen)

5.2. Measuring Standard

FCC Part 15, Subpart B, Class B ANSI C63.4: 2014

5.3. Radiated Emission Limits (Class B)

Frequency MHz	Distance Meters	Field Strengths Limit	
		$\mu\text{V}/\text{m}$	$\text{dB}(\mu\text{V})/\text{m}$
30 ~ 88	10	100	30.0
88 ~ 216	10	150	33.5
216 ~ 960	10	200	36.0
960 ~ 1000	10	500	44.0

Frequency (GHz)	Distance (Meters)	Field Strengths Limit	
		Average ($\text{dB}\mu\text{V}/\text{m}$)	Peak ($\text{dB}\mu\text{V}/\text{m}$)
1~6	3	54	74

Remark: (1) Emission level ($\text{dB}\mu\text{V}$) = $20 \log$ Emission level $\mu\text{V}/\text{m}$
 (2) The smaller limit shall apply at the cross point between two frequency bands.
 (3) Distance is the distance in meters between the measuring instrument, antenna and the closest point of any part of the device or system.

5.4. EUT Configuration on Measurement

The FCC Class B regulations test method must be used to find the maximum emission during radiated emission measurement.

EUT : Interactive Touch Screen
 Model Number : TWB-IB70

5.5. Operating Condition of EUT

5.5.1. Setup the EUT as shown on Section 5.1.

5.5.2. Turn on the power of all equipments.

5.5.3. Let the EUT work in measuring mode (AV in, Y+Pb+Pr in, HDMI in, USB Play, SD CARD play, VGA & Ping) and measure it.

5.6. Test Procedure

The EUT is placed on a turn table which is 0.1 meter high above the ground. The turn table can rotate 360 degrees to determine the position of the maximum emission level. The EUT is set 3/10 meters away from the receiving antenna which is mounted on a antenna tower. The antenna can be moved up and down from 1 to 4 meters to find out the maximum emission level. Bilog antenna (calibrated by Dipole Antenna) is used as a receiving antenna. Both horizontal and vertical polarization of the antenna are set on test.

The bandwidth of the Receiver (ESU26) is set at 120kHz.

All the modes were tested and the data of the worst modes (VGA(1920*1080) & Ping) are attached the following pages.

5.7. Measuring Results

PASS.

The frequency range from 30MHz to 6000MHz is investigated.

Please refer to the following pages.

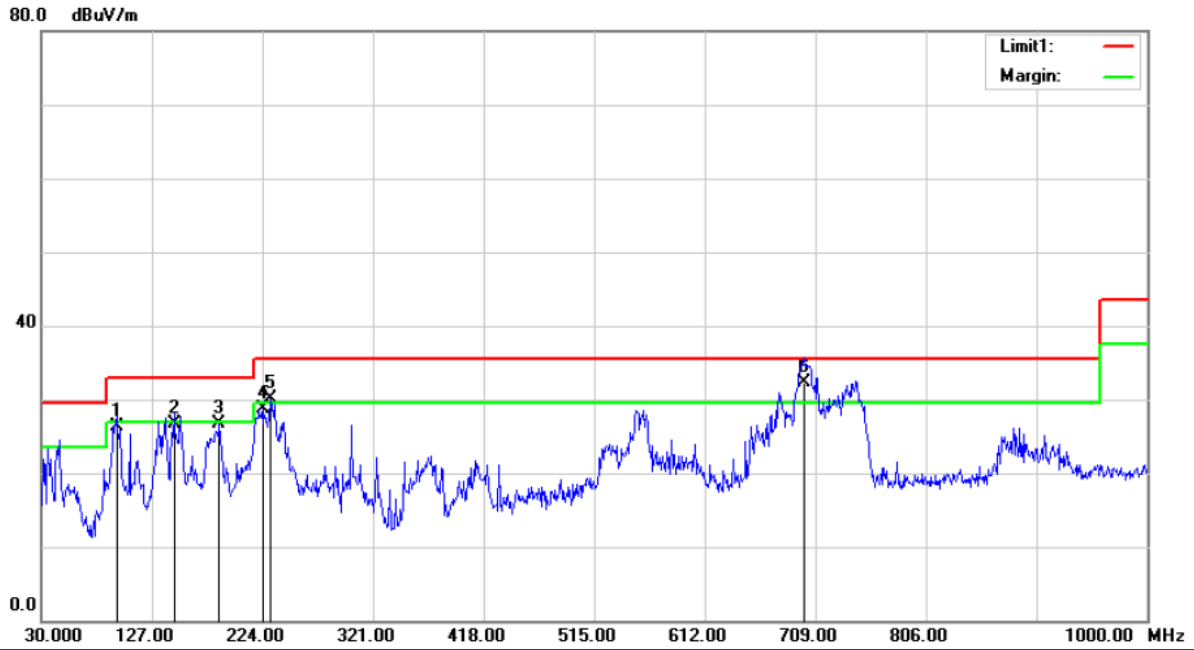

Site :10m Chamber #1
 Limit: (RE 10M)FCC 15 Class B
 EUT: Interactive Touch Screen
 M/N: TWB-IB70
 Mode:VGA(1920X1080)+PING
 Note:

Polarization: **Vertical**
 Power: AC 120V/60Hz
 Temperature: 26
 Humidity: 60 %

No.	Mk.	Freq.	Reading Level	Correct Factor	Measurement	Limit	Over	Antenna Height	Table Degree		
		MHz	dBuV	dB	dBuV/m	dBuV/m	dB	Detector	cm	degree	Comment
1		95.9600	58.62	-32.32	26.30	33.00	-6.70	QP	100	249	
2		146.4000	61.57	-34.87	26.70	33.00	-6.30	QP	100	183	
3		186.1700	59.25	-32.48	26.77	33.00	-6.23	QP	100	153	
4		224.9700	58.96	-30.31	28.65	35.50	-6.85	QP	100	153	
5	!	230.7900	60.20	-30.13	30.07	35.50	-5.43	QP	100	151	
6	*	699.3000	52.61	-20.31	32.30	35.50	-3.20	QP	100	153	

*:Maximum data x:Over limit !:over margin

Operator: CSL

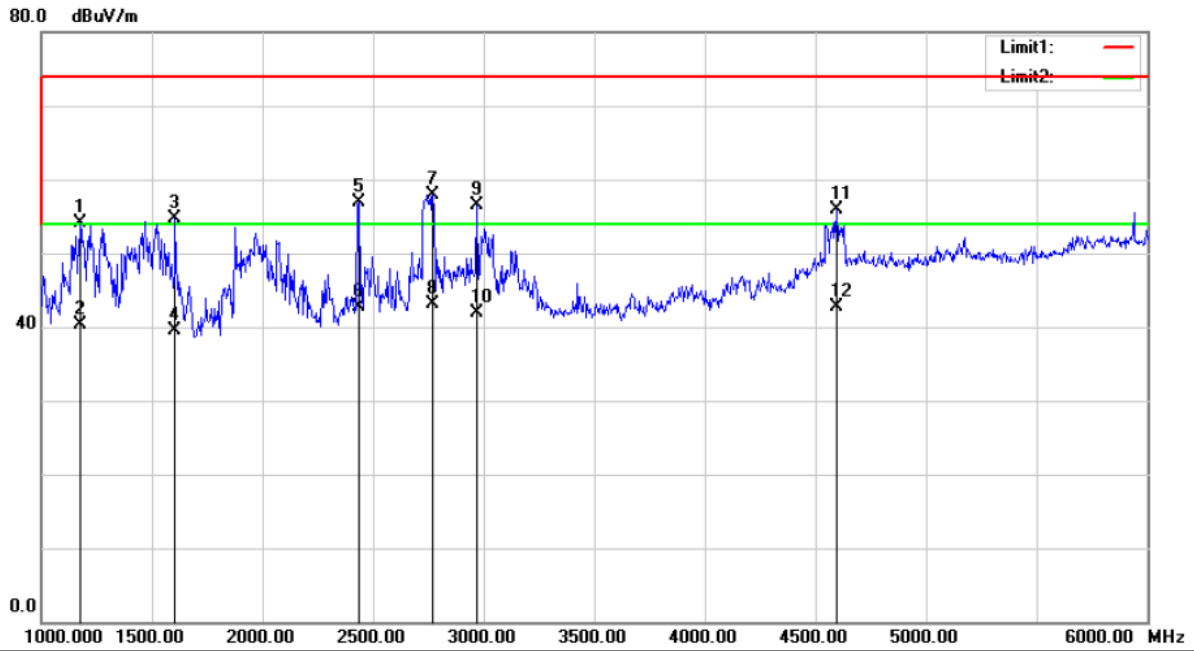

Site Conducted #3 Polarization: **Horizontal** Temperature: 24
 Limit: (RE)FCC PART 15 CLASS B Power: AC 120V/60Hz Humidity: 53 %
 EUT: InteractiveTouch Screen
 M/N: TWB-IB70
 Mode:VGA(1920*1080)&ping
 Note:

No.	Mk.	Freq.	Reading Level	Correct Factor	Measurement	Limit	Over	Antenna Height	Table Degree	
		MHz	dBuV	dB	dBuV/m	dBuV/m	dB	cm	degree	Comment
1		1175.000	67.00	-12.89	54.11	74.00	-19.89	QP	0	
2		1175.000	53.19	-12.89	40.30	54.00	-13.70	AVG	0	
3		1605.000	65.72	-10.93	54.79	74.00	-19.21	QP	0	
4		1605.000	50.43	-10.93	39.50	54.00	-14.50	AVG	0	
5		2435.000	64.93	-8.09	56.84	74.00	-17.16	QP	0	
6		2435.000	50.89	-8.09	42.80	54.00	-11.20	AVG	0	
7		2770.000	64.53	-6.59	57.94	74.00	-16.06	QP	0	
8	*	2770.000	49.69	-6.59	43.10	54.00	-10.90	AVG	0	
9		2970.000	62.16	-5.67	56.49	74.00	-17.51	QP	0	
10		2970.000	47.57	-5.67	41.90	54.00	-12.10	AVG	0	
11		4595.000	56.59	-0.71	55.88	74.00	-18.12	QP	0	
12		4595.000	43.51	-0.71	42.80	54.00	-11.20	AVG	0	

*:Maximum data x:Over limit !:over margin

Operator: Cai

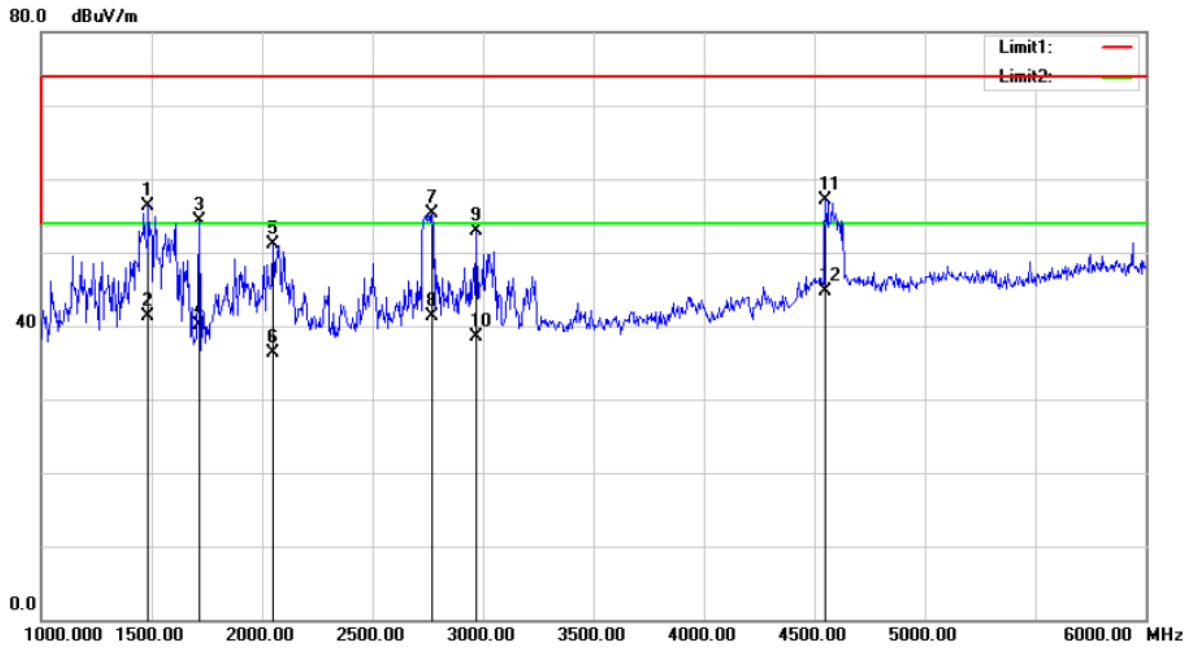

Site Conducted #3 Polarization: **Vertical** Temperature: 24
 Limit: (RE)FCC PART 15 CLASS B Power: AC 120V/60Hz Humidity: 53 %
 EUT: InteractiveTouch Screen
 M/N: TWB-IB70
 Mode:\VGA(1920*1080)&ping
 Note:

No.	Mk.	Freq.	Reading Level	Correct Factor	Measurement	Limit	Over	Antenna Height	Table Degree	
		MHz	dBuV	dB	dBuV/m	dBuV/m	dB	cm	degree	Comment
1		1485.000	68.16	-11.95	56.21	74.00	-17.79	QP	0	
2		1485.000	53.25	-11.95	41.30	54.00	-12.70	AVG	0	
3		1715.000	65.78	-11.42	54.36	74.00	-19.64	QP	0	
4		1715.000	51.62	-11.42	40.20	54.00	-13.80	AVG	0	
5		2050.000	61.65	-10.53	51.12	74.00	-22.88	QP	0	
6		2050.000	46.93	-10.53	36.40	54.00	-17.60	AVG	0	
7		2770.000	62.71	-7.32	55.39	74.00	-18.61	QP	0	
8		2770.000	48.62	-7.32	41.30	54.00	-12.70	AVG	0	
9		2970.000	59.31	-6.41	52.90	74.00	-21.10	QP	0	
10		2970.000	44.91	-6.41	38.50	54.00	-15.50	AVG	0	
11		4550.000	59.71	-2.52	57.19	74.00	-16.81	QP	0	
12	*	4550.000	47.22	-2.52	44.70	54.00	-9.30	AVG	0	

*:Maximum data x:Over limit !:over margin

Operator: Cai

-----The end-----