

**FCC 47 CFR PART 15 SUBPART B**

**CERTIFICATION TEST REPORT**

*For*

SHENZHEN Hitevision Technology Co., Ltd.

Interactive Touch Screen, LED Interactive Multi-Touch Display, Optimus-Touch Screen, Genee Touch, Interactive Led Monitor, Touch Pro

Model No.: TWB-IB65, TWB-IB65X, TWB-IB65AX, FM-A65, SV-XF6, Predia PRO OTS-65V3/15S, 65GT-DELX/H15, QIT1265 10BA, TT-6515B, TT-6515BX, TT-651XB, VI-65X1, TWB-IB65A, TWB-IBC65, TWB-IBC65X, TWB-IBC65AX, P-65Da, P-65X, 65G-Touch Slim-DELX, We-Touch 65-10T, HD-I6XXXE, HD-IXXXE, WS-Z6XXX(X=0-9 or A-Z)

FCC ID: 2ACYT-AHH15901-65

Prepared for : SHENZHEN Hitevision Technology Co., Ltd.  
Address : No. 8, Qinglan 1st Road, Pingshan, Shenzhen, Guangdong 518118, P. R. China

Prepared by : SHENZHEN EMTEK CO., LTD.  
Address : Bldg 69, Majialong Industry Zone, Nanshan District, Shenzhen, Guangdong, China

Tel: (0755) 26954280  
Fax: (0755) 26954282

Report Number : ES150810123E  
Date of Test : August 10, 2015 to September 11, 2015  
Date of Report : September 14, 2015

## TABLE OF CONTENT

Test Report Description	Page
<b>1. SUMMARY OF TEST RESULT .....</b>	<b>5</b>
<b>2. GENERAL INFORMATION .....</b>	<b>6</b>
2.1. Description of Device (EUT).....	6
2.2. Description of Test Facility.....	7
2.3. Description of Support Device.....	7
2.4. Measurement Uncertainty .....	7
<b>3. MEASURING DEVICE AND TEST EQUIPMENT .....</b>	<b>8</b>
3.1. For Power Line Conducted Emission Measurement.....	8
3.2. For Radiated Emission Measurement (10m Chamber).....	8
3.3. For Radiated Emission Measurement (3m Chamber).....	8
<b>4. POWER LINE CONDUCTED EMISSION MEASUREMENT .....</b>	<b>9</b>
4.1. Block Diagram of Test Setup .....	9
4.2. Measuring Standard .....	9
4.3. Power Line Conducted Emission Limits (Class B) .....	9
4.4. EUT Configuration on Measurement.....	9
4.5. Operating Condition of EUT .....	9
4.6. Test Procedure .....	10
4.7. Measuring Results.....	10
<b>5. RADIATED EMISSION MEASUREMENT.....</b>	<b>15</b>
5.1. Block Diagram of Test Setup .....	15
5.2. Measuring Standard .....	16
5.3. Radiated Emission Limits (Class B) .....	16
5.4. EUT Configuration on Measurement.....	16
5.5. Operating Condition of EUT .....	16
5.6. Test Procedure .....	16
5.7. Measuring Results.....	17

## TEST REPORT DESCRIPTION

Applicant : SHENZHEN Hitevision Technology Co., Ltd.  
Manufacturer : SHENZHEN Hitevision Technology Co., Ltd.  
Trademark :   
  
EUT : Interactive Touch Screen, LED Interactive Multi-Touch Display, Optimus-Touch Screen, Genee Touch, Interactive Led Monitor, Touch Pro  
Model No. : TWB-IB65, TWB-IB65X, TWB-IB65AX, FM-A65, SV-XF6, Predia PRO OTS-65V3/15S, 65GT-DELX/H15, QIT1265 10BA, TT-6515B, TT-6515BX, TT-651XB, VI-65X1, TWB-IB65A, TWB-IBC65, TWB-IBC65X, TWB-IBC65AX, P-65Da, P-65X, 65G-Touch Slim-DELX, We-Touch 65-10T, HD-I6XXXE, HD-IXXXE, WS-Z6XXX (X=0-9 or A-Z)  
Power Supply : AC 100-240V ~50/60Hz Max 2.5A

### Measurement Procedure Used:

FCC Rules and Regulations Part 15 : 2015 Subpart B Class B & FCC / ANSI C63.4-2014

The device described above is tested by SHENZHEN EMTEK CO., LTD. to determine the maximum emission levels emanating from the device and the severe levels of the device can endure and its performance criterion. The measurement results are contained in this test report and SHENZHEN EMTEK CO., LTD. is assumed full of responsibility for the accuracy and completeness of these measurements. Also, this report shows that the EUT (Equipment Under Test) is technically compliant with the FCC requirements.

This report applies to above tested sample only and shall not be reproduced in part without written approval of SHENZHEN EMTEK CO., LTD.

Date of Test : August 10, 2015 to September 11, 2015

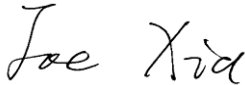
Prepared by :   
Joe Xia /Editor

Reviewer :   
Jack Li /Supervisor

Approve & Authorized Signer :   
Lisa Wang /Manager

### Modified Information

Version	Report No.	Revision Date	Summary
Ver.1.0	ES150810123E	/	Original Report

## 1. SUMMARY OF TEST RESULT

<b>EMISSION</b>		
Description of Test Item	Standard & Limits	Results
Conducted Disturbance at Mains Terminals	FCC Part 15, Subpart B, Class B ANSI C63.4: 2014	Pass
Radiated Disturbance	FCC Part 15, Subpart B, Class B ANSI C63.4: 2014	Pass
Note: N/A is an abbreviation for Not Applicable.		

## 2. GENERAL INFORMATION

### 2.1. Description of Device (EUT)

EUT	:	Interactive Touch Screen, LED Interactive Multi-Touch Display, Optimus-Touch Screen, Genee Touch, Interactive Led Monitor, Touch Pro
Model Number	:	TWB-IB65, TWB-IB65X, TWB-IB65AX, FM-A65, SV-XF6, Predia PRO OTS-65V3/15S, 65GT-DELX/H15, QIT1265 10BA, TT-6515B, TT-6515BX, TT-651XB, VI-65X1, TWB-IB65A, TWB-IBC65, TWB-IBC65X, TWB-IBC65AX, P-65Da, P-65X, 65G-Touch Slim-DELX, We-Touch 65-10T, HD-I6XXXE, HD-IXXXE, WS-Z6XXX (X=0-9 or A-Z) (Note: These models are identical in circuitry and electrical, mechanical and physical construction; the only difference is the model number. for trading purpose. We prepare TWB-IB65 for all test.)
Applicant	:	SHENZHEN Hitevision Technology Co., Ltd.
Address	:	No. 8, Qinglan 1st Road, Pingshan, Shenzhen, Guangdong 518118, P. R. China
Manufacturer	:	SHENZHEN Hitevision Technology Co., Ltd.
Address	:	No. 8, Qinglan 1st Road, Pingshan, Shenzhen, Guangdong 518118, P. R. China
Date of Received	:	August 10, 2015
Date of Test	:	August 10, 2015 to September 11, 2015

## 2.2. Description of Test Facility

### Site Description

- EMC Lab. : Accredited by CNAS, 2013.10.29  
The certificate is valid until 2016.10.28  
The Laboratory has been assessed and proved to be in compliance with CNAS-CL01: 2006(identical to ISO/IEC17025: 2005)  
The Certificate Registration Number is L2291
- : Accredited by TUV Rheinland Shenzhen, 2010.5.25  
The Laboratory has been assessed according to the requirements ISO/IEC 17025.
- : Accredited by FCC, July 24, 2013  
The Certificate Registration Number is 406365.
- : Accredited by FCC, April 17, 2013  
The Certificate Registration Number is 709623.
- : Accredited by Industry Canada, November 29, 2012  
The Certificate Registration Number is 4480A

## 2.3. Description of Support Device

- PC : Manufacturer: LENOVO  
M/N: 9702  
S/N: L3C4410  
CE, FCC: DOC
- LCD TV : Manufacturer: SONY  
M/N: KDL-24EX520  
S/N: 6258850  
CE , FCC,
- Keyboard : Manufacturer: LENOVO  
M/N: KU-0225  
S/N:0585494  
CE, FCC: DOC
- Mouse : Manufacturer: LENOVO  
M/N: MO28UOL  
S/N:44G7862 068  
CE, FCC: DOC

## 2.4. Measurement Uncertainty

- | Test Item                                      | Uncertainty   |
|--|---|
| Conducted Emission Uncertainty                 | : 2.96dB(9k~150kHz Conduction 1#)<br>2.74dB(150k-30MHz Conduction 1#) |
| Radiated Emission Uncertainty<br>(10m Chamber) | : 3.96dB (30M~1GHz Polarize: H)<br>4.04dB (30M~1GHz Polarize: V)      |
| Radiated Emission Uncertainty<br>(3m Chamber)  | : 4.46dB (1~6GHz)   |

### 3. MEASURING DEVICE AND TEST EQUIPMENT

#### 3.1. For Power Line Conducted Emission Measurement

Item	Equipment	Manufacturer	Model No.	Serial No.	Last Cal.	Cal. Interval
<input checked="" type="checkbox"/>	Test Receiver	Rohde & Schwarz	ESCI	26115-010-002 7	May 16, 2015	1 Year
<input checked="" type="checkbox"/>	L.I.S.N.	Rohde & Schwarz	ENV216	101161	May 16, 2015	1 Year
<input checked="" type="checkbox"/>	50Ω Coaxial Switch	Anritsu	MP59B	6100175589	May 16, 2015	1 Year
<input checked="" type="checkbox"/>	Voltage Probe	Rohde & Schwarz	ESH2-Z3	100122	May 16, 2015	1 Year

#### 3.2. For Radiated Emission Measurement (10m Chamber)

Item	Equipment	Manufacturer	Model No.	Serial No.	Last Cal.	Cal. Interval
<input checked="" type="checkbox"/>	EMI Test Receiver	Rohde & Schwarz	ESR3	1316.3003K03- 101706-HN	May 16, 2015	1 Year
<input checked="" type="checkbox"/>	EMI Test Receiver	Rohde & Schwarz	ESR3	1316.3003K03- 101707-Z1	May 16, 2015	1 Year
<input checked="" type="checkbox"/>	Pre-Amplifier	Lunar EM	LNA10M1G-40	J10111309120 01	May 16, 2015	1 Year
<input checked="" type="checkbox"/>	Pre-Amplifier	Lunar EM	LNA10M1G-40	J10111311260 02	May 16, 2015	1 Year
<input checked="" type="checkbox"/>	Bilog Antenna	Schwarzbeck	VULB9163	659	May 16, 2015	1 Year
<input checked="" type="checkbox"/>	Bilog Antenna	Schwarzbeck	VULB9163	661	May 16, 2015	1 Year

#### 3.3. For Radiated Emission Measurement (3m Chamber)

Item	Equipment	Manufacturer	Model No.	Serial No.	Last Cal.	Cal. Interval
<input checked="" type="checkbox"/>	EMI Test Receiver	Rohde & Schwarz	ESU	1302.6005.26	May 16, 2015	1 Year
<input checked="" type="checkbox"/>	Pre-Amplifier	A.H.	PAM-0126	1415261	May 16, 2015	1 Year
<input checked="" type="checkbox"/>	Horn Antenna	Schwarzbeck	BBHA 9120	707	May 16, 2015	1 Year



## 4. POWER LINE CONDUCTED EMISSION MEASUREMENT

### 4.1. Block Diagram of Test Setup

For Connect to PC:

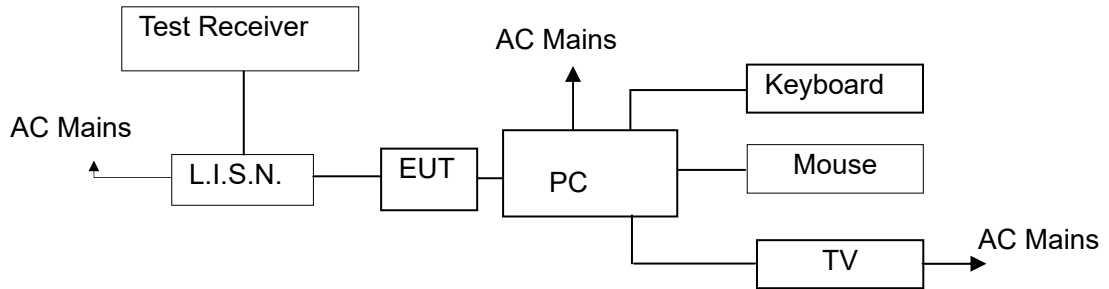

(EUT: Interactive Touch Screen)

### 4.2. Measuring Standard

FCC Part 15, Subpart B, Class B ANSI C63.4: 2014

### 4.3. Power Line Conducted Emission Limits (Class B)

Frequency (MHz)	Limit (dB $\mu$ V)	
	Quasi-peak Level	Average Level
0.15 ~ 0.50	66.0 ~ 56.0 *	56.0 ~ 46.0 *
0.50 ~ 5.00	56.0	46.0
5.00 ~ 30.00	60.0	50.0

NOTE1-The lower limit shall apply at the transition frequencies.  
NOTE2-The limit decreases linearly with the logarithm of the frequency in the range 0.15MHz to 0.50MHz.

### 4.4. EUT Configuration on Measurement

The following equipments are installed on Conducted Emission Measurement to meet FCC requirements and operating in a manner which tends to maximize its emission characteristics in a normal application.

EUT : Interactive Touch Screen  
Model Number : TWB-IB65

### 4.5. Operating Condition of EUT

4.5.1. Setup the EUT as shown on Section 4.1.

4.5.2. Turn on the power of all equipments.

4.5.3. Let the EUT work in measuring mode (AV in, Y+Pb+Pr in, HDMI in, USB Play, SD CARD play, VGA & Ping) and measure it.

#### 4.6. Test Procedure

The EUT is put on the plane 0.1m high above the ground by insulating support and connected to the AC mains through Line Impedance Stability Network (L.I.S.N). This provided a 50ohm coupling impedance for the tested equipments. Both sides of AC line are investigated to find out the maximum conducted emission according to the FCC regulations during conducted emission measurement.

The bandwidth of the field strength meter (R&S Test Receiver ESCS30) is set at 9kHz in 150kHz~30MHz and 200Hz in 9kHz~150kHz.

The frequency range from 150kHz to 30MHz is investigated.

All the modes were tested and the data of the worst modes (VGA(1920\*1080) & Ping) are attached the following pages.

#### 4.7. Measuring Results

**PASS.**

Please refer to the following pages.

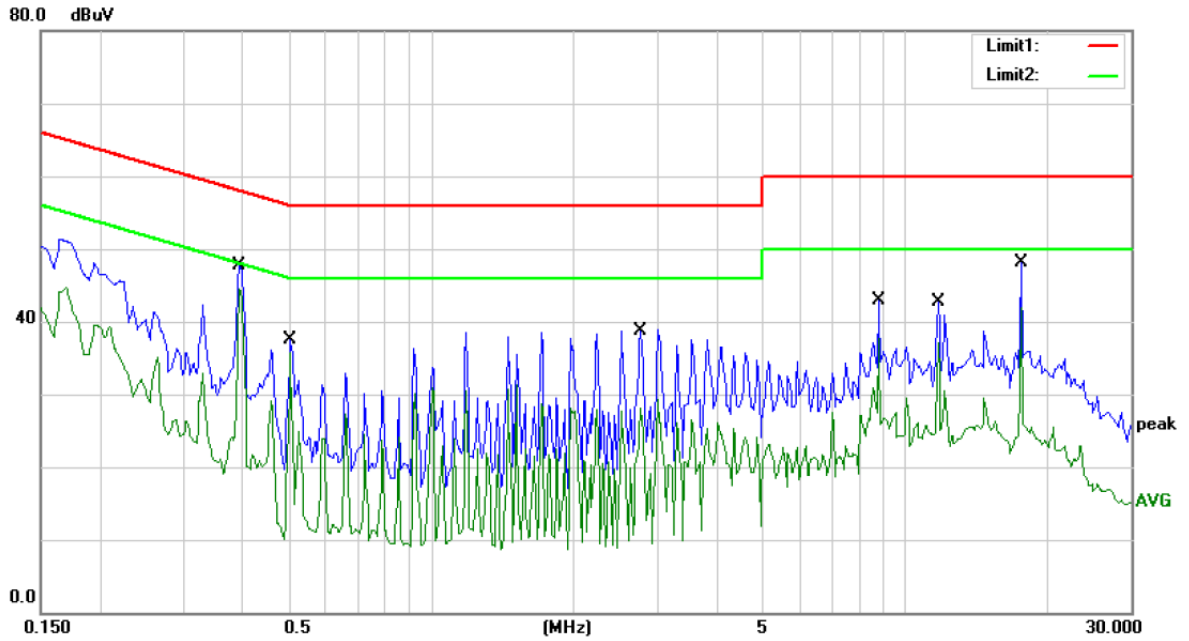

Site Conduction #2

Phase: **L1**

Temperature: 26

Limit: (CE)FCC PART15 Class B\_QP

Power: AC 120V/60Hz

Humidity: 55 %

Mode: VGA(1920\*1080)&Ping

Note:

No.	Mk.	Freq. MHz	Reading Level dBuV	Correct Factor dB	Measure- ment dBuV	Limit dBuV	Over dB	Detector	Comment
1		0.3950	47.67	0.00	47.67	57.96	-10.29	QP	
2	*	0.3950	44.48	0.00	44.48	47.96	-3.48	AVG	
3		0.5050	37.44	0.00	37.44	56.00	-18.56	QP	
4		0.5050	35.65	0.00	35.65	46.00	-10.35	AVG	
5		2.7650	38.65	0.00	38.65	56.00	-17.35	QP	
6		2.7650	28.13	0.00	28.13	46.00	-17.87	AVG	
7		8.8100	42.83	0.00	42.83	60.00	-17.17	QP	
8		8.8100	37.65	0.00	37.65	50.00	-12.35	AVG	
9		11.7500	42.62	0.00	42.62	60.00	-17.38	QP	
10		11.7500	37.09	0.00	37.09	50.00	-12.91	AVG	
11		17.6250	48.08	0.00	48.08	60.00	-11.92	QP	
12		17.6250	42.00	0.00	42.00	50.00	-8.00	AVG	

\*:Maximum data    x:Over limit    !:over margin    Comment: Factor build in receiver.    Operator: Neo

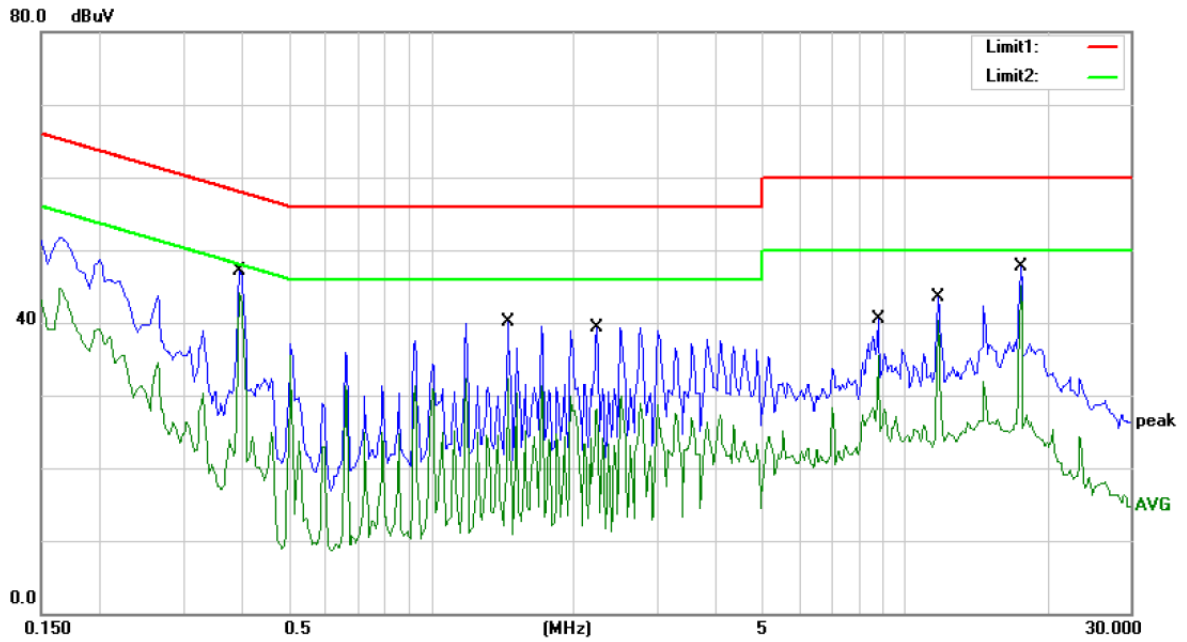

Site Conduction #2

Phase: **N**

Temperature: 26

Limit: (CE)FCC PART15 Class B\_QP

Power: AC 120V/60Hz

Humidity: 55 %

Mode: VGA(1920\*1080)&Ping

Note:

No.	Mk.	Freq.	Reading Level	Correct Factor	Measurement	Limit	Over	Detector	Comment
		MHz	dBuV	dB	dBuV	dBuV	dB		
1		0.3950	47.08	0.00	47.08	57.96	-10.88	QP	
2	*	0.3950	44.10	0.00	44.10	47.96	-3.86	AVG	
3		1.4500	40.18	0.00	40.18	56.00	-15.82	QP	
4		1.4500	32.39	0.00	32.39	46.00	-13.61	AVG	
5		2.2400	39.37	0.00	39.37	56.00	-16.63	QP	
6		2.2400	28.19	0.00	28.19	46.00	-17.81	AVG	
7		8.8100	40.49	0.00	40.49	60.00	-19.51	QP	
8		8.8100	35.54	0.00	35.54	50.00	-14.46	AVG	
9		11.7500	43.57	0.00	43.57	60.00	-16.43	QP	
10		11.7500	40.33	0.00	40.33	50.00	-9.67	AVG	
11		17.6250	47.68	0.00	47.68	60.00	-12.32	QP	
12		17.6250	45.13	0.00	45.13	50.00	-4.87	AVG	

\*:Maximum data    x:Over limit    !:over margin    Comment: Factor build in receiver.    Operator: Neo

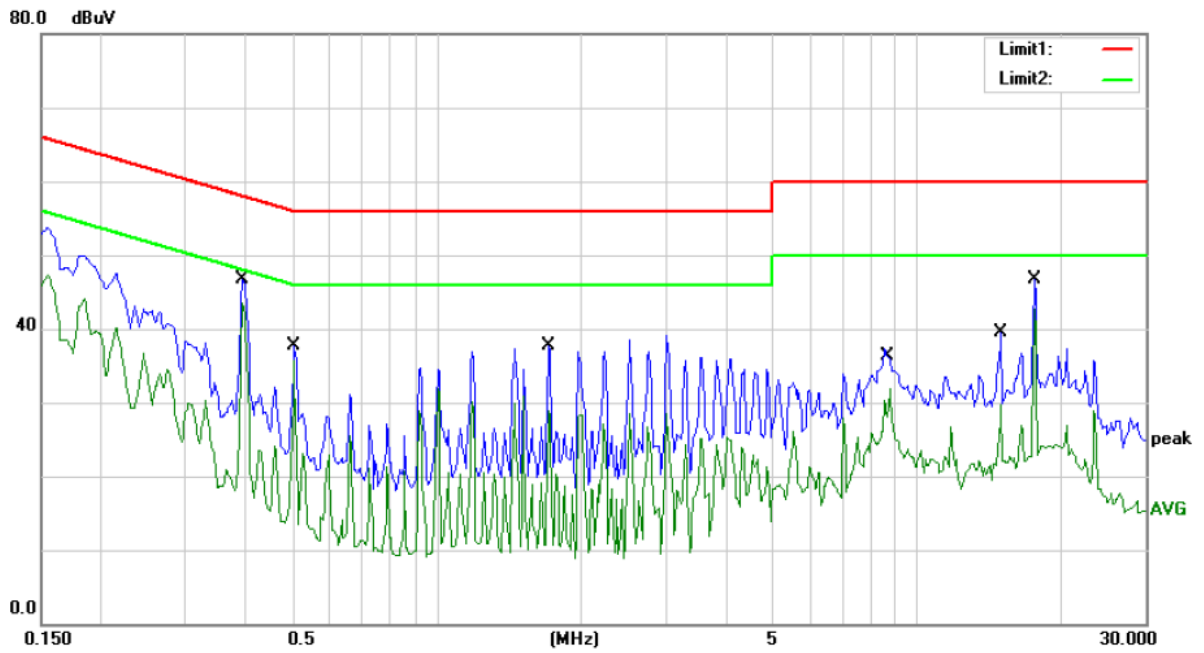

Site Conduction #2

Phase: **L1**

Temperature: 26

Limit: (CE)FCC Part15 class B\_QP

Power: AC 240V/50Hz

Humidity: 55 %

Mode: VGA(1920\*1080)&Ping

Note:

No.	Mk.	Freq.	Reading Level	Correct Factor	Measurement	Limit	Over	Detector	Comment
		MHz	dBuV	dB	dBuV	dBuV	dB		
1		0.3950	46.62	0.00	46.62	57.96	-11.34	QP	
2	*	0.3950	43.47	0.00	43.47	47.96	-4.49	AVG	
3		0.5050	37.76	0.00	37.76	56.00	-18.24	QP	
4		0.5050	35.76	0.00	35.76	46.00	-10.24	AVG	
5		1.7150	37.71	0.00	37.71	56.00	-18.29	QP	
6		1.7150	28.92	0.00	28.92	46.00	-17.08	AVG	
7		8.8100	37.38	0.00	37.38	60.00	-22.62	QP	
8		8.8100	31.81	0.00	31.81	50.00	-18.19	AVG	
9		15.0000	39.53	0.00	39.53	60.00	-20.47	QP	
10		15.0000	29.75	0.00	29.75	50.00	-20.25	AVG	
11		17.6250	46.62	0.00	46.62	60.00	-13.38	QP	
12		17.6250	42.68	0.00	42.68	50.00	-7.32	AVG	

\*:Maximum data    x:Over limit    !:over margin    Comment: Factor build in receiver.    Operator: Neo

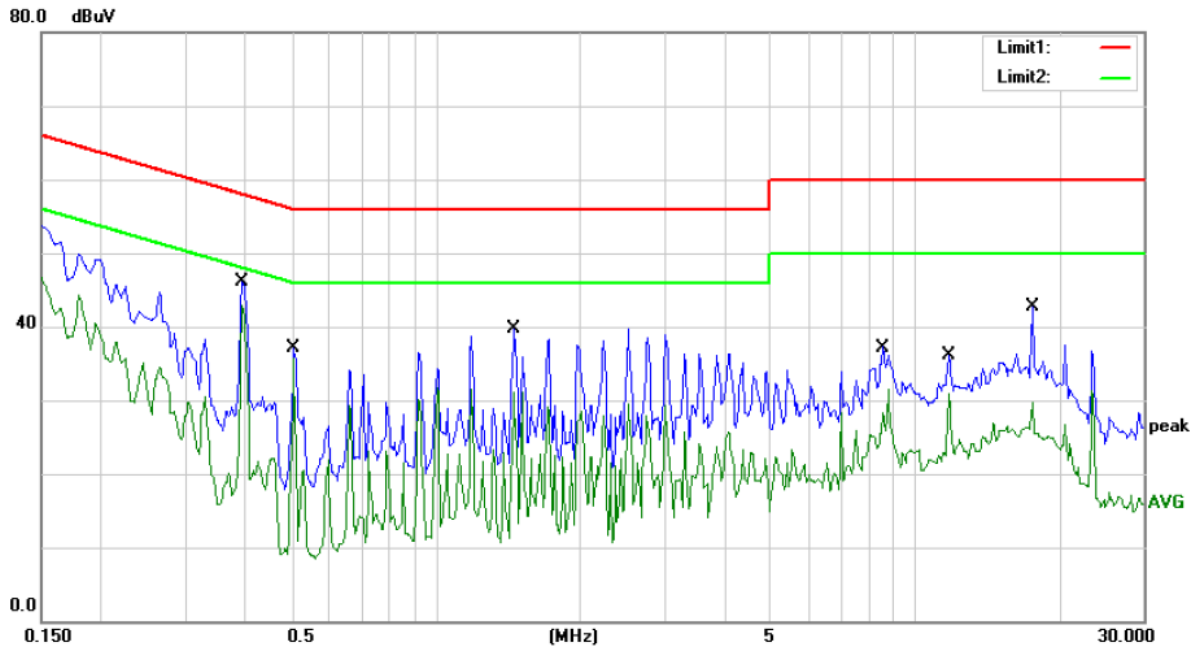

Site Conduction #2

Phase: **N**

Temperature: 26

Limit: (CE)FCC Part15 class B\_QP

Power: AC 240V/50Hz

Humidity: 55 %

Mode: VGA(1920\*1080)&Ping

Note:

No.	Mk.	Freq.	Reading Level	Correct Factor	Measurement	Limit	Over	Detector	Comment
		MHz	dBuV	dB	dBuV	dBuV	dB		
1		0.3950	46.05	0.00	46.05	57.96	-11.91	QP	
2	*	0.3950	42.89	0.00	42.89	47.96	-5.07	AVG	
3		0.5050	37.10	0.00	37.10	56.00	-18.90	QP	
4		0.5050	35.65	0.00	35.65	46.00	-10.35	AVG	
5		1.4500	39.72	0.00	39.72	56.00	-16.28	QP	
6		1.4500	31.20	0.00	31.20	46.00	-14.80	AVG	
7		8.5600	37.20	0.00	37.20	60.00	-22.80	QP	
8		8.5600	31.43	0.00	31.43	50.00	-18.57	AVG	
9		11.7500	36.11	0.00	36.11	60.00	-23.89	QP	
10		11.7500	30.88	0.00	30.88	50.00	-19.12	AVG	
11		17.6000	42.71	0.00	42.71	60.00	-17.29	QP	
12		17.6000	29.72	0.00	29.72	50.00	-20.28	AVG	

\*:Maximum data    x:Over limit    !:over margin    Comment: Factor build in receiver.    Operator: Neo

## 5. RADIATED EMISSION MEASUREMENT

### 5.1. Block Diagram of Test Setup

#### 5.1.1. Block diagram of EUT System

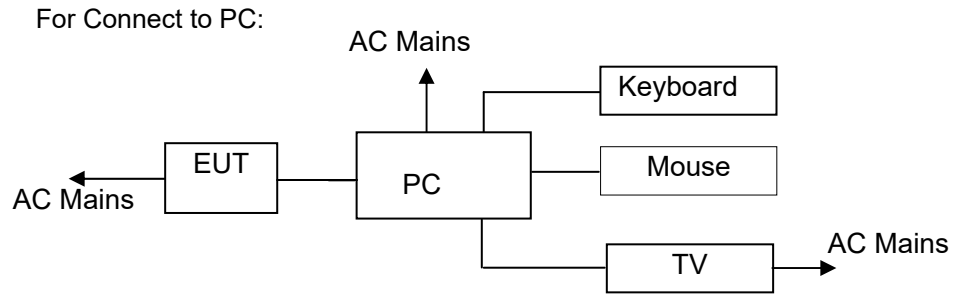

(EUT: Interactive Touch Screen)

#### 5.1.2. Block diagram of test setup (In chamber)

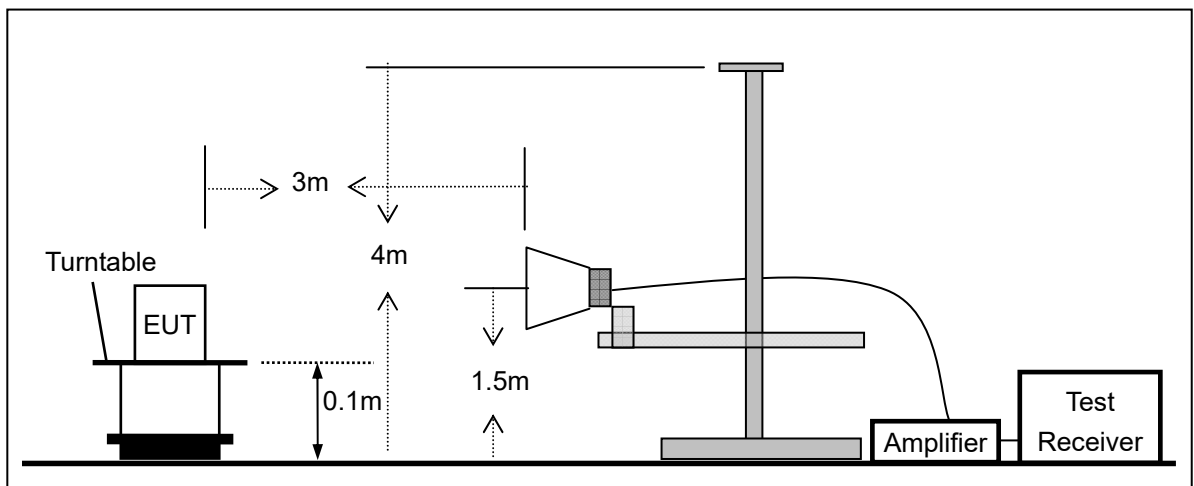
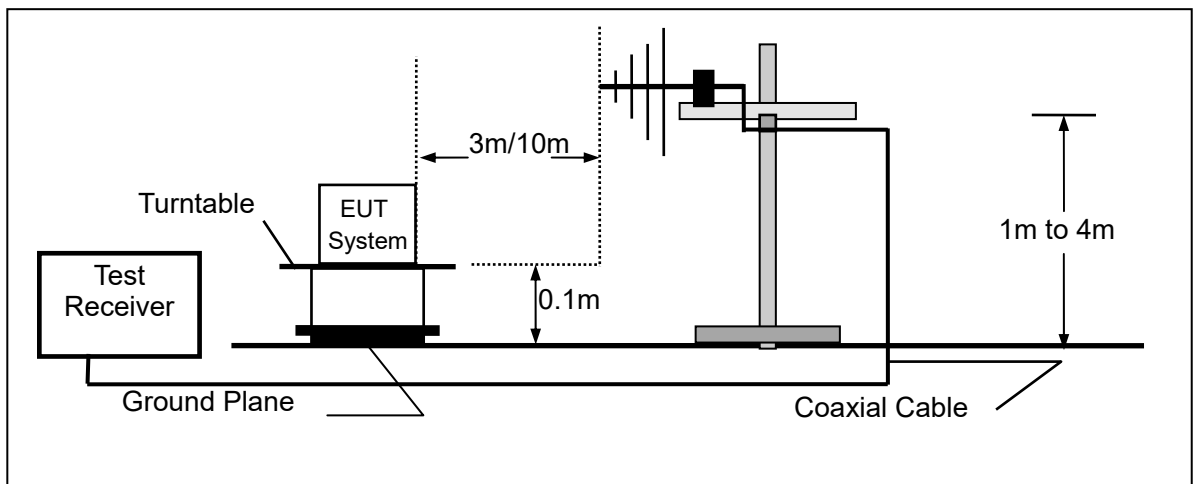

(EUT: Interactive Touch Screen)

## 5.2. Measuring Standard

FCC Part 15, Subpart B, Class B ANSI C63.4: 2014

## 5.3. Radiated Emission Limits (Class B)

Frequency MHz	Distance Meters	Field Strengths Limit	
		$\mu\text{V}/\text{m}$	$\text{dB}(\mu\text{V})/\text{m}$
30 ~ 88	10	100	30.0
88 ~ 216	10	150	33.5
216 ~ 960	10	200	36.0
960 ~ 1000	10	500	44.0

Frequency (GHz)	Distance (Meters)	Field Strengths Limit	
		Average ( $\text{dB}\mu\text{V}/\text{m}$ )	Peak ( $\text{dB}\mu\text{V}/\text{m}$ )
1~6	3	54	74

Remark: (1) Emission level ( $\text{dB}\mu\text{V}$ ) =  $20 \log$  Emission level  $\mu\text{V}/\text{m}$   
 (2) The smaller limit shall apply at the cross point between two frequency bands.  
 (3) Distance is the distance in meters between the measuring instrument, antenna and the closest point of any part of the device or system.

## 5.4. EUT Configuration on Measurement

The FCC Class B regulations test method must be used to find the maximum emission during radiated emission measurement.

EUT : Interactive Touch Screen  
 Model Number : TWB-IB65

## 5.5. Operating Condition of EUT

5.5.1. Setup the EUT as shown on Section 5.1.

5.5.2. Turn on the power of all equipments.

5.5.3. Let the EUT work in measuring mode (AV in, Y+Pb+Pr in, HDMI in, USB Play, SD CARD play, VGA & Ping) and measure it.

## 5.6. Test Procedure

The EUT is placed on a turn table which is 0.1 meter high above the ground. The turn table can rotate 360 degrees to determine the position of the maximum emission level. The EUT is set 3/10 meters away from the receiving antenna which is mounted on a antenna tower. The antenna can be moved up and down from 1 to 4 meters to find out the maximum emission level. Bilog antenna (calibrated by Dipole Antenna) is used as a receiving antenna. Both horizontal and vertical polarization of the antenna are set on test.

The bandwidth of the Receiver (ESU26) is set at 120kHz.

All the modes were tested and the data of the worst modes (VGA(1920\*1080) & Ping) are attached the following pages.



## 5.7. Measuring Results

**PASS.**

The frequency range from 30MHz to 6000MHz is investigated.

Please refer to the following pages.

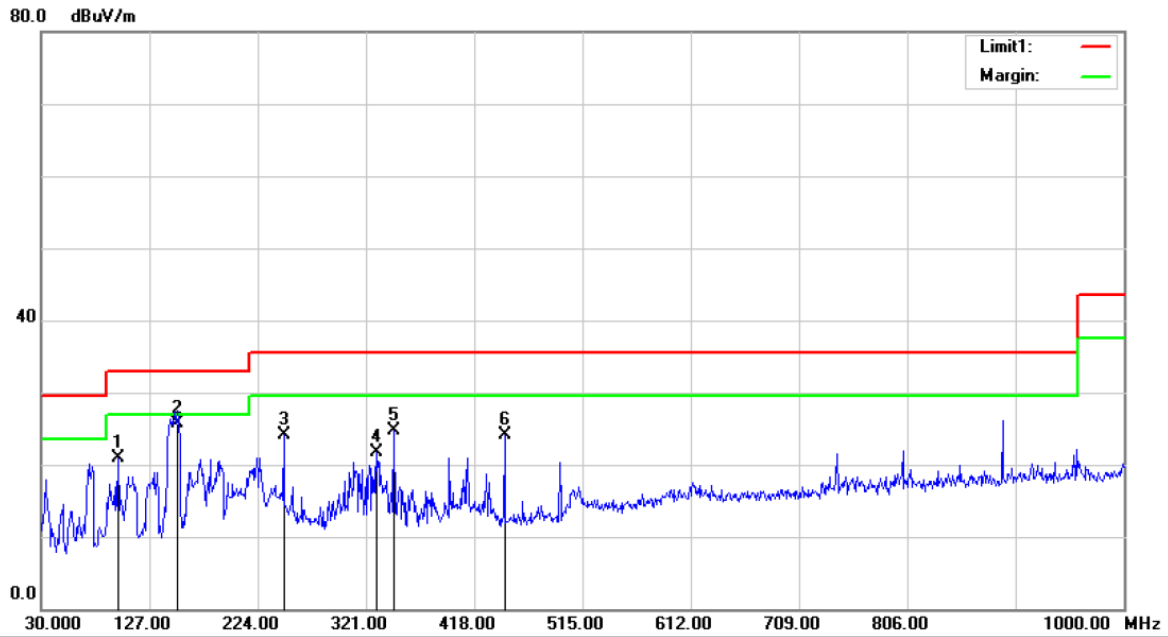

Site :10m Chamber #1      Polarization: **Horizontal**      Temperature: 26  
 Limit: (RE 10M)FCC 15 Class B      Power: AC 120V/60Hz      Humidity: 60 %  
 Mode:VGA(1920X1080)&Ping  
 Note:

No.	Mk.	Freq. MHz	Reading Level dBuV	Correct Factor dB	Measure- ment dBuV/m	Limit dBuV/m	Over dB	Antenna Height cm	Table Degree	Comment
1		98.8700	53.36	-32.52	20.84	33.00	-12.16	QP 308	359	
2	*	152.2200	61.19	-35.49	25.70	33.00	-7.30	QP 308	64	
3		247.2800	54.87	-30.73	24.14	35.50	-11.36	QP 400	216	
4		330.7000	50.54	-28.78	21.76	35.50	-13.74	QP 400	23	
5		346.2200	53.07	-28.43	24.64	35.50	-10.86	QP 308	351	
6		445.1600	50.51	-26.40	24.11	35.50	-11.39	QP 400	227	

\*:Maximum data    x:Over limit    !:over margin

Operator: CSL

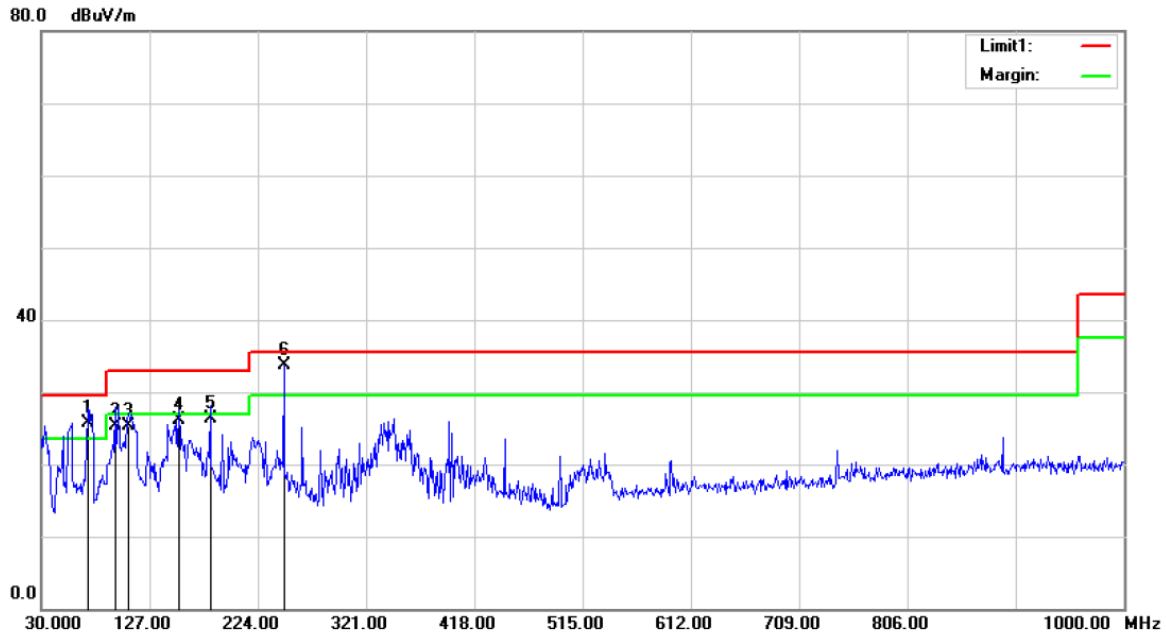

Site :10m Chamber #1      Polarization: **Vertical**      Temperature: 26  
 Limit: (RE 10M)FCC 15 Class B      Power: AC 120V/60Hz      Humidity: 60 %  
 Mode:VGA(1920X1080)&Ping  
 Note:

No.	Mk.	Freq.	Reading Level	Correct Factor	Measurement	Limit	Over	Antenna Height	Table Degree	
		MHz	dBuV	dB	dBuV/m	dBuV/m	dB	cm	degree	Comment
1	!	71.7100	60.01	-34.21	25.80	29.50	-3.70	200	359	
2		95.9600	57.72	-32.32	25.40	33.00	-7.60	100	44	
3		107.6000	56.95	-31.65	25.30	33.00	-7.70	200	347	
4		153.1900	60.77	-34.57	26.20	33.00	-6.80	100	10	
5		181.3200	59.27	-32.97	26.30	33.00	-6.70	100	287	
6	*	247.2800	63.38	-29.63	32.45	35.50	-3.05	100	334	

\*:Maximum data    x:Over limit    !:over margin

Operator: CSL

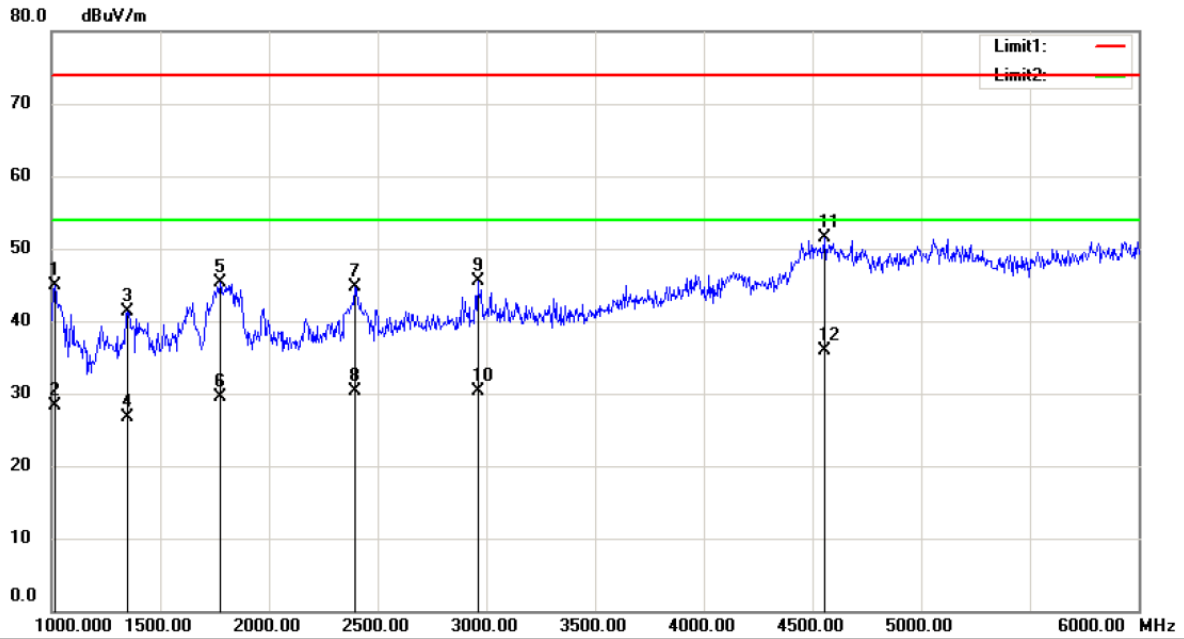

Site 3m Chamber #1

Polarization: **Horizontal**

Temperature: 22 C

Limit: (RE)FCC PART 15 CLASS B PEAK

Power: AC 120V/60Hz

Humidity: 50 %

Mode:VGA(1920x1080)&Ping

Note:

No.	Mk.	Freq.	Reading Level	Correct Factor	Measurement	Limit	Over	Antenna Height	Table Degree	
		MHz	dBuV	dB	dBuV/m	dBuV/m	dB	cm	degree	Comment
1		1015.000	58.50	-13.62	44.88	74.00	-29.12			peak
2		1015.000	41.92	-13.62	28.30	54.00	-25.70			AVG
3		1350.000	53.20	-11.88	41.32	74.00	-32.68			peak
4		1350.000	38.58	-11.88	26.70	54.00	-27.30			AVG
5		1775.000	55.60	-10.37	45.23	74.00	-28.77			peak
6		1775.000	39.97	-10.37	29.60	54.00	-24.40			AVG
7		2395.000	52.82	-8.21	44.61	74.00	-29.39			peak
8		2395.000	38.61	-8.21	30.40	54.00	-23.60			AVG
9		2960.000	51.20	-5.78	45.42	74.00	-28.58			peak
10		2960.000	36.18	-5.78	30.40	54.00	-23.60			AVG
11		4555.000	52.98	-1.52	51.46	74.00	-22.54			peak
12	*	4555.000	37.42	-1.52	35.90	54.00	-18.10			AVG

\*:Maximum data    x:Over limit    !:over margin

Operator: KK

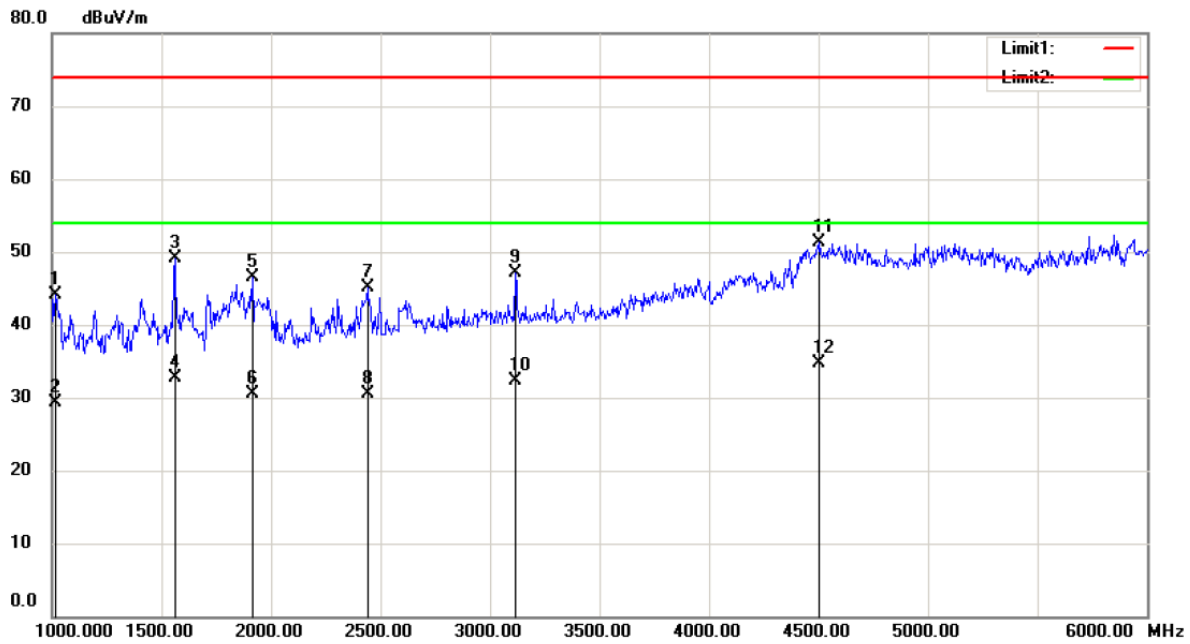

Site 3m Chamber #1 Polarization: **Vertical** Temperature: 22 C  
 Limit: (RE)FCC PART 15 CLASS B PEAK Power: AC 120V/60Hz Humidity: 50 %  
 Mode:VGA(1920x1080)&Ping  
 Note:

No.	Mk.	Freq.	Reading Level	Correct Factor	Measurement	Limit	Over	Antenna Height	Table Degree	
		MHz	dBuV	dB	dBuV/m	dBuV/m	dB	cm	degree	Comment
1		1015.000	57.75	-13.62	44.13	74.00	-29.87			peak
2		1015.000	43.02	-13.62	29.40	54.00	-24.60			AVG
3		1560.000	60.10	-10.93	49.17	74.00	-24.83			peak
4		1560.000	43.73	-10.93	32.80	54.00	-21.20			AVG
5		1915.000	56.57	-10.00	46.57	74.00	-27.43			peak
6		1915.000	40.60	-10.00	30.60	54.00	-23.40			AVG
7		2440.000	53.19	-8.03	45.16	74.00	-28.84			peak
8		2440.000	38.63	-8.03	30.60	54.00	-23.40			AVG
9		3115.000	52.65	-5.52	47.13	74.00	-26.87			peak
10		3115.000	37.82	-5.52	32.30	54.00	-21.70			AVG
11		4505.000	52.90	-1.68	51.22	74.00	-22.78			peak
12	*	4505.000	36.48	-1.68	34.80	54.00	-19.20			AVG

\*:Maximum data x:Over limit !:over margin

Operator: KK

-----The end-----