

MultiHaul™ TG

Wireless 60 GHz L2 SDN Mesh
for Multi-Gigabit Ethernet

Installation, Operation and Maintenance Manual

Trademarks

Siklu, the Siklu logo, and MultiHaul™ are all trademarks of Siklu Communication Ltd. All other product names and trademarks mentioned in this document are trademarks or registered trademarks of their respective companies.

Copyrights

Copyright © 2021 Siklu Communication Ltd. All rights reserved.

No part of this publication may be reproduced or distributed in any form or by any means, or stored in a database or retrieval system, without the prior written consent of Siklu.

Disclaimers

The information contained in this document is subject to change without notice.

Siklu assumes no responsibility for any errors that may appear. Siklu makes no warranties, expressed or implied, by operation of law or otherwise, relating to this document, the products or the computer software programs described herein.

This document was originally written in English. Please refer to the English language version for a full and accurate description of all products and services described herein.



Contents

| | |
|---|----|
| 1. Introduction | 5 |
| 1.1 Scope | 5 |
| 1.2 Applicable Products and Releases..... | 5 |
| 1.3 Audience | 5 |
| 1.4 Conventions | 5 |
| 1.5 List of Abbreviations..... | 6 |
| 2. Safety and Regulatory Notices..... | 7 |
| 2.1 General | 7 |
| 2.2 FCC Regulatory Statements..... | 7 |
| 2.3 Canada Regulatory Statements..... | 7 |
| 2.4 EU Regulatory Notes | 10 |
| 3. MultiHaul™ TG Overview..... | 11 |
| 4. Installing the MultiHaul™ TG Units | 13 |
| 4.1 Preparing the Site | 13 |
| 4.1.1 Physical and Environmental Requirements..... | 13 |
| 4.1.2 Cabling Requirements..... | 14 |
| 4.1.3 Node Orientation | 15 |
| 4.2 MultiHaul™ TG Package Contents..... | 15 |
| 4.3 Unpacking the MultiHaul™ TG Units..... | 15 |
| 4.4 Required Tools | 15 |
| 4.5 Mounting and Aligning the MultiHaul™ TG Node on a Pole..... | 16 |
| 4.6 Mounting the MultiHaul™ TG Node on a Wall | 22 |
| 4.7 Mounting and Aligning the MultiHaul™ TG TU on a Pole or Wall..... | 23 |
| 4.8 Connecting Cables | 24 |
| 4.8.1 Connecting the Cables to the MultiHaul™ TG Node..... | 24 |
| 4.8.2 Connecting the Cables to the MultiHaul™ TG TU | 25 |
| 4.8.3 Weatherproofing the Cables..... | 25 |
| 4.8.4 Grounding MultiHaul™ TG Units | 26 |
| 4.8.5 Installing Lightning Surge Protectors on Cables..... | 27 |
| 4.8.6 Powering Units..... | 27 |
| 4.8.7 Connecting Other Network Cables..... | 27 |
| 4.9 Unit LEDs..... | 28 |
| 4.10 Link Up Verification | 29 |
| 4.10.1 Node Checks | 29 |
| 4.10.2 TU Checks..... | 29 |



| | |
|---|----|
| 4.10.3 Configuring the System..... | 29 |
| 4.11 Resetting the Unit..... | 30 |
| 5. Management Concepts..... | 31 |
| 4.1 Connecting to the CLI..... | 31 |
| 4.2 Configuring Management IPv4 Address \ Default Gateway | 32 |



1. Introduction

1.1 Scope

This document describes how to install, configure, operate and maintain the MultiHaul™ TG, Siklu's Wireless 60 GHz L2 SDN Mesh for Multi-Gigabit Ethernet.

1.2 Applicable Products and Releases

- MultiHaul™ TG NodeN366
- MultiHaul™ TG Terminal Unit (TU) T265
- MultiHaul™ TG Software MH-TG-1.0

1.3 Audience

This document assumes a working knowledge of wireless connectivity platforms and their operating environments.

This document is intended for use by persons involved in planning, installing, configuring, and using the MultiHaul™ TG units.

1.4 Conventions

The following conventions are used in this document in order to make locating, reading, and using information easier.



Note: Informs you of an optional activity that may be performed at this stage.



Caution: Informs you that if you do not proceed as instructed, damage to or destruction of equipment, loss of functionality, or a health hazard to personnel may result.



Warning: Warns you that if you do not proceed as instructed, personal injury or loss of life could result.



1.5 List of Abbreviations

| Abbreviation | Description |
|--------------|--|
| CDRH | Center for Devices and Radiological Health, a branch of the United States Food and Drug Administration (FDA) |
| FOV | Field Of View |
| MTU | Maximum Transmission Unit |
| NVRAM | Non-Volatile Random Access Memory |
| OTA | Over The Air |
| PD | Powered Device |
| PHY | Physical layer |
| PoE | Power over Ethernet |
| PoP | Point of Presence |
| PSE | Power Sourcing Equipment |
| PtMP | Point To MultiPoint |
| RAM | Random Access Memory |
| SaaS | Software as a Service |
| SDN | Software-Defined Networking |
| SFF | Small Form Factor |
| SFP | Small Form-Factor Pluggable |
| TU | Terminal Unit |
| UV | Ultraviolet |



2. Safety and Regulatory Notices

The following are mandatory notices for installation and operation of MultiHaul™ TG Wireless Backhaul System. Indications appearing here are required by the designated government and regulatory agencies for purposes of safety and compliance.

2.1 General



Verify that your installation matches local codes, including insertion of surge protectors when PoE power is provided from an injector that not certified for outdoor lines.



Do not install or operate the MultiHaul™ TG units in the presence of flammable gases or fumes. Operating any electrical instrument in such an environment is a safety hazard.

2.2 FCC Regulatory Statements

This equipment has been tested and found to comply with the limits for a Class B digital device, pursuant to Part 15 of the FCC Rules. These limits are designed to provide reasonable protection against harmful interference in a residential installation. This equipment generates uses and can radiate radio frequency energy and, if not installed and used in accordance with the instructions, may cause harmful interference to radio communications. However, there is no guarantee that interference will not occur in any installation scenario. If this equipment does cause harmful interference to radio or television reception, which can be determined by turning the equipment off and on, the user is encouraged to try to correct the interference by one or more of the following measures:

- Reorient or relocate the receiving antenna.
- Increase the separation between the equipment and receiver.
- Connect the equipment into an outlet on a circuit different from that to which the receiver is connected.
- Consult the dealer or an experienced radio/TV technician for help.



Changes or modifications to this equipment not expressly approved by the party responsible for compliance (Siklu Communication Ltd) could void the user's authority to operate the equipment.

2.3 Canada Regulatory Statements

This Class B digital apparatus complies with Canadian ICES-003.

Cet appareil numérique de la classe B est conforme à la norme NMB-003 du Canada.

This device complies with Innovation, Science and Economic Development Canada's license-exempt RSS standard (s). Operation is subject to two conditions: (1) This device may not cause harmful interference, and (2) this device must accept any interference that may be received or that may cause undesired operation.

Le présent appareil est conforme aux CNR d'Innovation, Sciences et Développement économique Canada applicables aux appareils radio exempts de licence. L'exploitation est autorisée aux deux conditions suivantes : (1) l'appareil ne doit pas produire de brouillage, et (2) l'utilisateur de l'appareil doit accepter tout brouillage radioélectrique subi, même si le brouillage est susceptible d'en compromettre le fonctionnement.



2.4 EU Regulatory Notes

This product meets the technical requirements of ECC REC 07-03 (7 June 2019), Table 3, bracket C2, with operation at 60.48 GHz and 62.64 GHz and radiated transmitted power (EIRP) under 40 dBm. In some EU countries outdoor operation of this device is not permitted. If in doubt, please enquire with your Telecommunications Regulator.



Changes or modifications to this equipment not expressly approved by Siklu Communication Ltd or the party responsible for compliance could void the user's authority to operate the equipment.



Outdoor units and antennas should be installed **ONLY** by experienced installation professionals who are familiar with local building and safety codes and, wherever applicable, are licensed by the appropriate government regulatory authorities. Failure to do so may void the product warranty and may expose the end user or the service provider to legal and financial liabilities. Siklu Communication Ltd and its resellers or distributors are not liable for injury, damage or violation of regulations associated with the installation of outdoor units or antennas.



Les unités extérieures et les antennes doivent être installées par des professionnels expérimentés d'installation qui sont familiers avec les normes locales et les codes de sécurité et, si applicable, sont agréées par les autorités gouvernementales. Ne pas le faire peut annuler la garantie du produit et peut exposer l'utilisateur final ou le fournisseur de services à des obligations juridiques et financières. Les revendeurs ou distributeurs de ces équipements ne sont pas responsables des blessures, des dommages ou violations des règlements liés à l'installation des unités extérieures ou des antennes. L'installateur doit configurer le niveau de puissance de sortie des antennes conformément aux réglementations nationales et au type d'antenne.



3. MultiHaul™ TG Overview

The MultiHaul™ TG family is an advanced solution for fixed wireless delivery of multi-Gigabit services to homes, businesses and within smart cities Broadband IoT applications. It is complemented by additional Siklu solutions for network design and operation, the SmartHaul™ suite of SaaS applications and services, together with EtherHaul™, a series of very high capacity PtP wireless links.

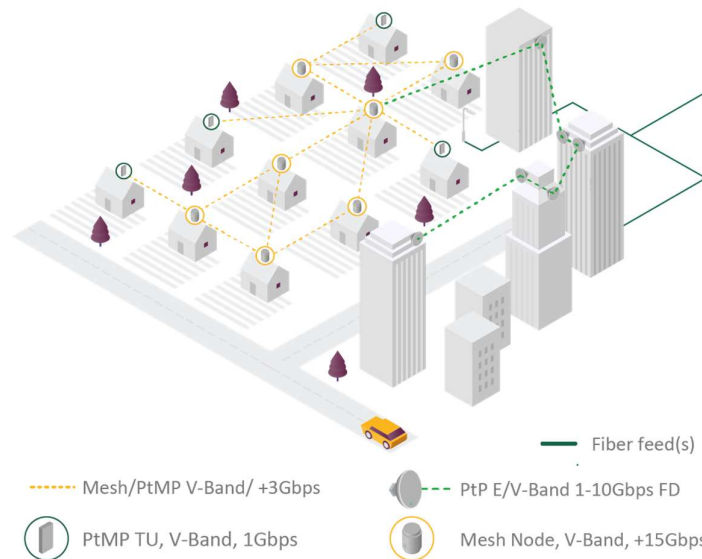

MultiHaul™ TG is the culmination of innovation for L2 SDN mesh carrier-class systems operating in the uncongested, unlicensed V-band, delivering very high capacity over small to large neighborhoods for a wide range of applications. The plug and play units are designed for easy installation by a single technician, using a single cable for power and data.

This section provides a brief overview of the MultiHaul™ TG units.

The MultiHaul™ TG family consists of the following units:

- MultiHaul™ TG N366 - a compact multi-sector unit deployed as a L2 SDN mesh node with built-in self-backhaul. Nodes can connect to additional N366 nodes to build a resilient wireless backbone across the served area, or to a network POP via either a fiber connection or a Siklu EtherHaul™ link with up to 10 Gbps FD.
- MultiHaul™ TG T265 - terminal units (TUs) deliver up to 1 GbE wirelessly to served locations. A smart beam-forming antenna provides for easy installation of a high capacity reliable wireless link by a single person, and serves one to three end-units per location.

N366 Node

Featuring 4 independent 90° sectors for a complete 360° coverage, a single node can be installed on a pole or roof to serve multiple locations. The node supports up to 15 TUs in each 90° sector when the sector does not self-backhaul to other nodes, up to a total of 60 TUs per N366. Each sector can also support 1 or 2 self-backhaul links, reducing the number of TUs that can be supported to 13 or 14 respectively (each backhaul link comes at the expense of a TU link).



The main features of the node include:

- 4 x 90° sectors.
- 4600 Mbps aggregate capacity OTA (over the air) per sector.
- 3 ports:
 - RJ-45 port with PoE-In, and capable of speeds from 1 Gbps to 2.5, 5 and 10 Gbps.
 - RJ-45 port with PoE-Out, and capable of speeds up to 1Gbps.
 - SFP+ socket for SMF or MMF connections at speeds of up to 1 Gbps or 10 Gbps, depending on the inserted SFP device.
- On-board web GUI or CLI, for local or remote management and operations.
- Centralized management via SmartHaul™ EMS.

T265 TUs

Featuring 90° scanning for easy installation, long distance and high performance, a TU can be installed on a pole or wall to serve between 1 - 3 connected devices with a copper or fiber interface. Additionally, the PSE/PoE-Out feature simplifies installation of the served devices by removing the need for additional power equipment.

The main features of the TU include:

- 90° horizontal scanning.
- 4600 Mbps aggregate capacity OTA (over the air).
- Up to 1 Gbps traffic.
- Up to 3 Ports, model dependent:
 - RJ-45 ports with PoE-In, and capable of 2.5 and 1Gbps speeds.
 - Optional RJ-45 port with PoE-Out.
 - SFP+ socket for connection of SMF or MMF at speeds of up 10 Gbps.
- On-board Web EMS or CLI, for local or remote management and operations.
- Centralized management via SmartHaul™ EMS.

Additional information is provided in this manual, as well as in the N366 and T26x datasheets and product descriptions.



4. Installing the MultiHaul™ TG Units

This section describes how to install the MultiHaul™ TG nodes and TUs.

4.1 Preparing the Site

Carefully select and prepare each site to make installation and configuration as simple and trouble-free as possible. During site selection and preparation, take into account local safety regulations and consider the long-term needs of both your network and your applications.



Installation and maintenance of the MultiHaul™ TG link should only be done by service personnel who are properly trained and certified to carry out such activities.

L'installation et l'entretien d'une unité MultiHaul™ TG ne doivent être effectués que par du personnel de service qui sont formés et accrédités pour mener à bien ces activités.

Minimum safe distance from antenna while radiating is 29.75 cm / 11.7 in (general public) or 13.3 cm / 5.2 in (occupational) (according to calculation done based on "Environmental evaluation and exposure limit according to FCC CFR 47 part 1, 1.1307, 1.1310; RSS-102, Safety Code 6).

Distance de sécurité minimum de l'antenne rayonnante est 29.75 cm (selon le calcul fait sur la base de "l'évaluation environnementale et la limite d'exposition en accordance avec FCC CFR 47 part 1, 1,1307, 1,1310, RSS-102, CODE 6 sécurité).

4.1.1 Physical and Environmental Requirements

Each site should meet the following requirements:

- There must be a clear, unobstructed line-of-sight between the units.
- MultiHaul™ TG units should be mounted on a fixed, stable, permanent structure. Units can be mounted using the following methods:
 - On reinforced steel mounting poles with the following diameters:
 - Node - 1.5" - 12"
 - TU - 1.5" - 4"



2" - 4" poles are recommended, in which case you can use the provided self-locking bands.

- Directly on a wall using the AX-MK-WM accessory, ordered separately from Siklu or your reseller.



Do not mount a MultiHaul™ TG unit on a structure that is temporary or easily moved. Doing so may result in poor service or equipment damage.



4.1.2 Cabling Requirements

- Install the MultiHaul™ TG unit where network connections and optional power cabling are ready for operation and easily accessible.
- All cabling connected to the MultiHaul™ TG unit should be outdoor grade, with UV protection.
- Use the following cables as per your type of connection:
 - 1 GbE - Cat5e (or higher) shielded outdoor cables terminated with metallic RJ45 connectors.
 - 10 GbE - Cat6 (or higher) shielded outdoor cables terminated with metallic RJ45 connectors.
- The MultiHaul™ TG unit is powered through the PoE input (ETH1). Take into account the power requirements of the MultiHaul™ TG unit (see [Section 3.2 - Technical Specifications](#) and external PD(s) when planning Ethernet cabling and passive POE Midspan/Injectors.
- PSE Output (PoE Out) is available on MultiHaul™ TG units with more than a single Ethernet port.
- PSE port output voltage is nearly the same as PoE port input voltage. The total cable length from the PoE injector or PSE device to the last powered device (PD) should not exceed 100 meters (PSE to first unit + first unit to second unit).



- PSE output is available only if the unit is powered directly by a power source such as 48VDC, or a PoE Injector/Midspan.
- One MultiHaul™ TG unit will power a 2nd unit, however that 2nd unit cannot power a third unit.
- You must also consider proper power-in limitations to avoid damage to the first or second unit in the chain.

- In order to protect indoor equipment, you must install surge protection circuits on all copper cables on their entrance to the building.
- Install the MultiHaul™ TG unit in a location where proper electrical outdoor grounding is readily available. Typically, the grounding connection is attached directly to the mounting pole. If not already present, then suitable structure-to-earth grounding connections must be created before installation. Ground the unit using 16 AWG diameter (minimum) grounding cable or according to local electrical code.



Improper electrical grounding can result in excessive electromagnetic interference or electrical discharge.

Siklu will not be held responsible for any malfunction or damage if the unit is not properly grounded.



4.1.3 Node Orientation

The network has been carefully designed by your or Siklu.'s Planning Team to achieve the highest standards in availability and reliability, taking into account all potential lines of sight between the large quantity of units in your network. It is critical to implement the orientation of the multi-sector nodes as they are designed by the planners of the network. Sector 1 is the reference sector for node orientation. Make sure you obtain the azimuth for sector 1 from your or Siklu's Planning Team before installing, and align sector 1 along this planned azimuth, as described in [Section 4.5 - Mounting and Aligning the MultiHaul™ TG Node on a Pole](#), Step 7.

4.2 MultiHaul™ TG Package Contents

The MultiHaul™ TG N366 or T265 packages include the following components:

| Description | N366 | T265 |
|--|------|---------------------------|
| MultiHaul™ TG unit | 1 | 1 |
| MultiHaul™ TG mounting bracket | 1 | 1 (attached to the TU) |
| Unit grounding cable (90 cm / 35.4 in) | 1 | 1 |
| All-weather shells | 2 | 2 |
| Self-locking bands | 2 | 2 |
| PoE injector with AC cable | - | 1 |

4.3 Unpacking the MultiHaul™ TG Units

Before installation, the MultiHaul™ TG package content should be examined carefully that all parts listed in the Quick Start Guide are present and there is no visible damage.



Unpack the MultiHaul™ TG components with care to avoid damaging or scratching the antenna radome.

4.4 Required Tools

The following tools are required for MultiHaul™ TG installation:

- Philips screwdriver, medium size head
- 7 mm hex socket driver
- Standard open-end wrench, 13 mm for the port caps
- Cutter
- Cable ties (for securing network and optional power cables)
- Cable labeling



4.5 Mounting and Aligning the MultiHaul™ TG Node on a Pole

To mount the node on a pole:

1. Insert self-locking bands in the mounting bracket.



The self-locking bands provided with the node are suitable for poles with a diameter of 1.5"-4". Poles with a diameter of 2"-4" are recommended.

2. Align the mounting bracket with the arrow pointing up and mount it on the pole.



Do NOT tighten the self-locking bands yet.

3. If all four sectors have a clear field of view and are not blocked by the pole, tighten the self-locking bands.



4. Ensure that the 4 mounting bracket screws are open.



5. Slide the node into the mounting bracket.

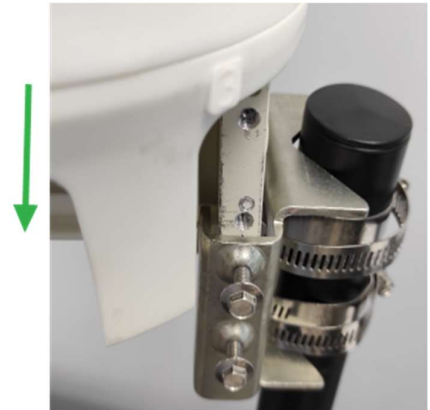

6. Tighten the four mounting bracket screws so that the node is securely fixed to the mounting bracket.

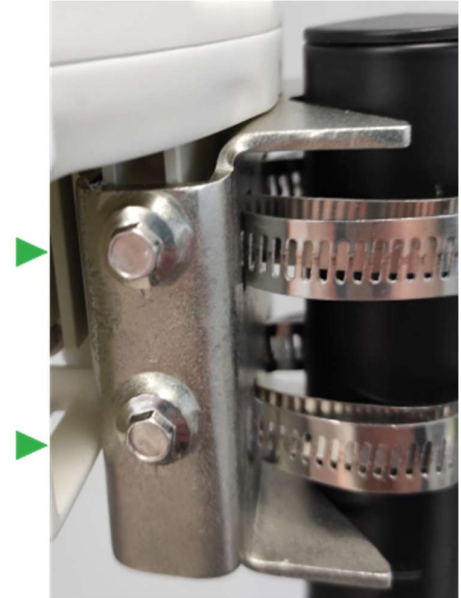

The node is now mounted on the pole.



7. Visually verify that the node's Sector 1 is aligned in accordance to the network design and instructions you received from your or Siklu's Planning Team (see [Section 4.1.3 - Node Orientation](#)). If required, slightly release the self-locking bands and optimize the azimuth alignment by turning the mounting bracket.

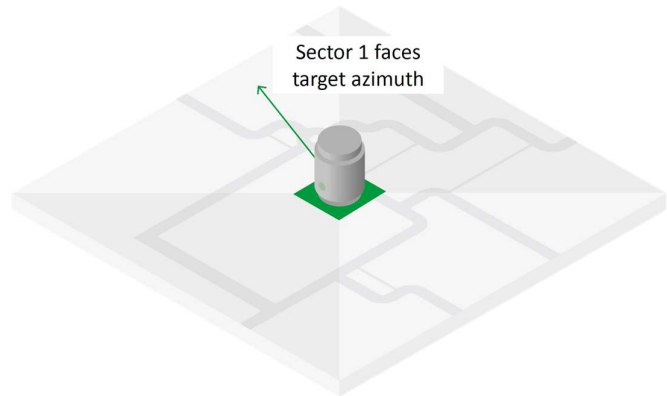

Each sector is identified by the number that appears below the sector panel.



8. Once sector 1 faces the target azimuth, tighten the self-locking bands if required to secure the bracket to the mounting pole.



4.6 Mounting the MultiHaul™ TG Node on a Wall

The node can be mounted on a wall using the AX-MK-WM accessory and four wall-mount screws (not provided), as shown in the following figure:



Order the AX-MK-WM accessory separately from Siklu or your reseller.



4.7 Mounting and Aligning the MultiHaul™ TG TU on a Pole or Wall

The TU is provided with a pre-attached mounting bracket suitable for mounting on a pole or wall.

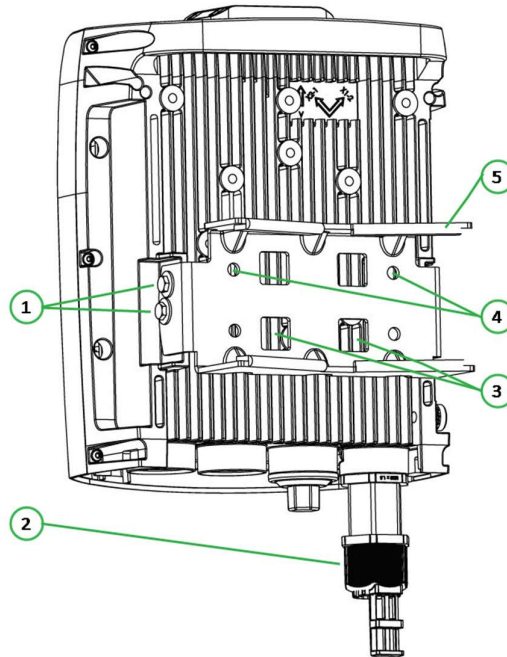

1. Elevation lock bolts (2 x 7 mm on each side)
2. All-weather shells (1 or 3, depending on model)
3. Self-locking bands fixing points (for 2 x 130 mm bands provided)

4. Wall-mount fixing holes (4)
5. Mounting bracket

Field of View Considerations while Mounting



TUs should be pointed towards the node.

When mounting the TU using the attached mounting bracket, the FOV (field-of-view) of the TU is as follows:

- horizontal: $\pm 45^\circ$ electronically.
- vertical : $\pm 35^\circ$ (25° electronically and 10° mechanical adjustment, achieved through the elevation lock bolts).







- When mounting the TU on a pole: if additional vertical adjustment is required, use the EH-MK-SM mounting kit.
- When mounting the TU on a wall using the attached mounting bracket: if additional horizontal adjustment is required, use the AX-MK-WM accessory.
- When mounting the TU on a wall: if both additional horizontal and vertical adjustment are required, use the EH-MK-SM mounting kit and the AX-MK-WM accessory together.

4.8 Connecting Cables

4.8.1 Connecting the Cables to the MultiHaul™ TG Node

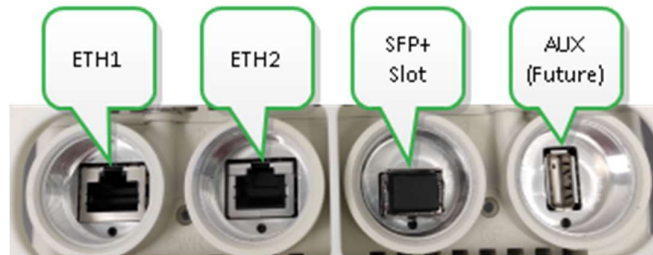
The MultiHaul™ TG node includes the following ports on the connector panel under the node, as shown and described below:



| Port | Connector Type | Description |
|------|----------------|--|
| ETH1 | RJ45 | <ul style="list-style-type: none"> • 10 GbE (10/5/2.5/1 GbE) • PoE in |
| ETH2 | RJ45 | <ul style="list-style-type: none"> • 1 GbE • PoE out |
| ETH3 | SFP+ | <ul style="list-style-type: none"> • 1 GbE • 10 GbE |
| | |  <p>Use only Class 1 Laser SFP/SFP+ with rated voltage of 3.3 Vdc which is safety approved to UL/EN/IEC 60950-1, and is CDRH (Center for Devices and Radiological Health) registered if deploying in the USA.</p> |
| AUX | USB | For future use |



4.8.2 Connecting the Cables to the MultiHaul™ TG TU

The MultiHaul™ TG TU includes the following ports on the connector panel under the TU, as shown and described below:

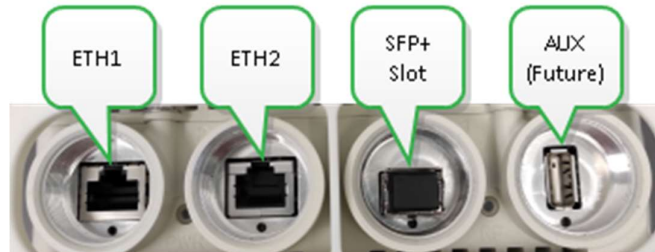

| Port | Connector Type | Description |
|---|----------------|--|
| ETH1 | RJ45 | <ul style="list-style-type: none"> • 10 GbE (2.5/1 GbE) • PoE in |
| ETH2 (T265-CCP only) | RJ45 | <ul style="list-style-type: none"> • 1 GbE • PoE out |
| ETH3 (T265-CCP only) | SFP+ | <ul style="list-style-type: none"> • 1 GbE • 10 GbE |
| <p>Use only Class 1 Laser SFP with rated voltage of 3.3 Vdc which is safety approved to UL/EN/IEC 60950-1 and which is CDRH registered.</p> | | |
| AUX | USB | For future use |

4.8.3 Weatherproofing the Cables

Before connecting a cable to a unit, you must first enclose the cable connector in a protective all-weather shell. Up to two sets of all-weather shells are provided with the unit. Additional all-weather shells can be purchased from Siklu or your reseller (P/N EH-AWS-SHORT).

The provided protective all-weather shells fit cables from 3.5 mm to 9.0 mm in diameter.

In some installations, the cables to the units are protected inside a 3/4" flexible conduit. Siklu provides an adapter to maintain the Ingress Protection (IP) rating of the installation by matching the all-weather shell termination to a Liquid Tight Adaptor (LTA) of your choice. The adapter can be purchased from Siklu or your reseller (P/N EH-AWS-ADAPT-CNDUIT).



To weatherproof the cables:

1. Thread the connectorized cable through the lock and shell, and plug it into the corresponding port.
2. Tighten the shell to the unit firmly by hand (do not use tools).
3. Pick a rubber gasket matching the cable diameter and insert the gasket snugly into the shell.

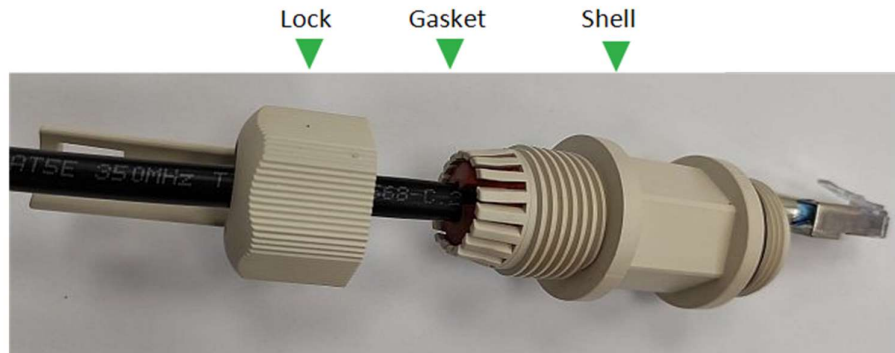

4. Secure the connector lock (do not use tools).
5. Attach the cable to the lock with two cable ties.



To avoid accidental damage to the connector, unlock the lock before removing the shell.

4.8.4 Grounding MultiHaul™ TG Units

1. Connect one end of the grounding cable to the ground lug terminal. Secure the screw.



2. Connect the other end of the grounding cable to the ground connection. If the ground connection is out of reach of the grounding cable, install a longer cable using 16 AWG grounding cable minimum or according to local electrical code.



4.8.5 Installing Lightning Surge Protectors on Cables



Verify that your installation matches local codes, including insertion of surge protectors when PoE power is provided from an injector that not certified for outdoor lines.

A lightning surge protector should be installed on every ethernet cable to protect the indoor networking equipment. The lightning surge arrester should be installed next to the cable point-of-entry and must be properly grounded, as shown in the following figure.

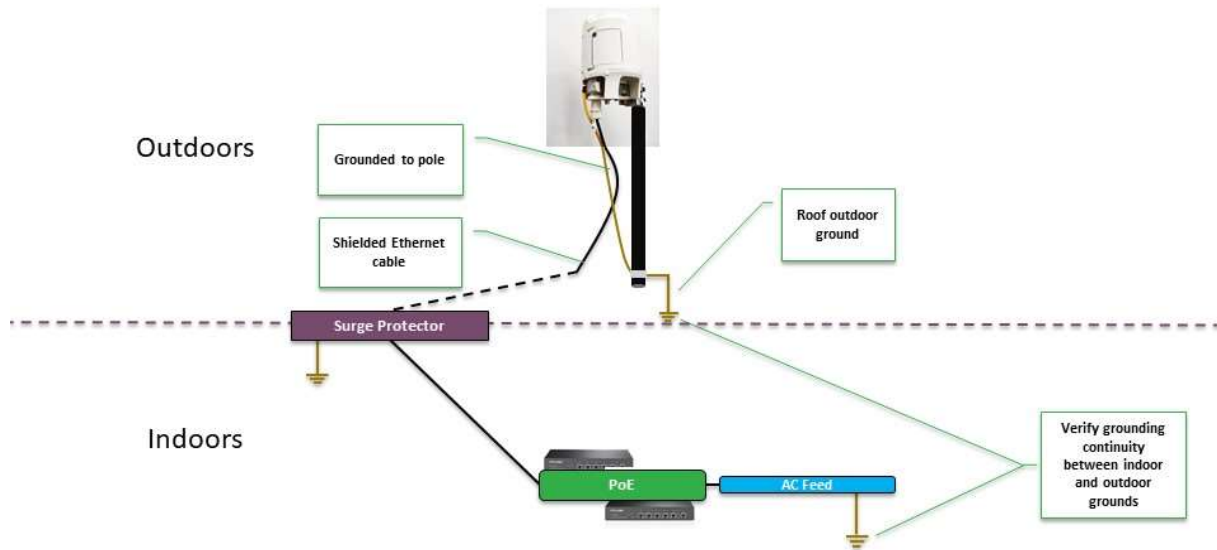

4.8.6 Powering Units

You can power the unit using one of the following methods:

- PoE through the Ethernet cable connected to ETH1.
- Direct DC (input range: 36÷57 Vdc) by using an RJ45-DC adapter that can be purchased from Siklu or your reseller (P/N EH-PoE-DC-adaptor). In this case, port ETH1 will be used for power only.



Use a PoE power supply which is safety approved to UL/EN/IEC 60950-1 as a limited power source (LPS) with rated voltage of 42-57 Vdc and rated current of 2.5 A max, and approved for the altitude where it is deployed.

To power up the MultiHaul™ TG:

1. Connect the ethernet cable with PoE or direct DC cable to port ETH1.

4.8.7 Connecting Other Network Cables

1. Connect any other network cables (ETH2, ETH3) as required by the deployment plan.



4.9 Unit LEDs

The MultiHaul™ TG unit includes the following LEDs on the connector panel under the unit, as shown and described below:

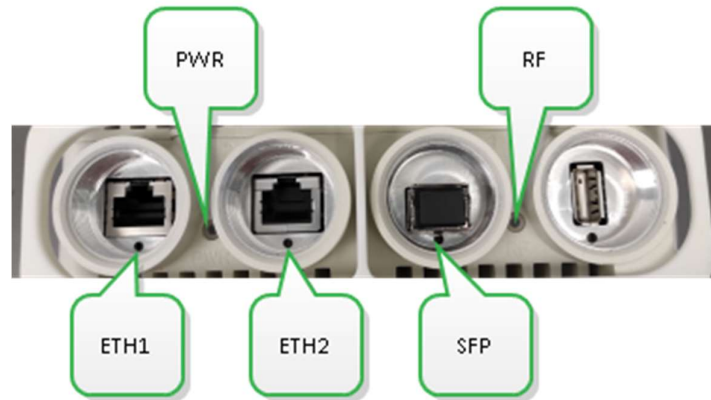

| LED | Color | Description |
|-------------------------------|--------|--|
| PWR (Power) | Green | <ul style="list-style-type: none"> On - power is on. Blinking - booting up. |
| | Orange | <ul style="list-style-type: none"> On - booting up (boot failure if LED remains on for more than 2 seconds). |
| | Red | <ul style="list-style-type: none"> Blinking - when reset pushbutton is released. |
| | Off | <ul style="list-style-type: none"> No power. |
| RF | Green | <ul style="list-style-type: none"> Node: on - at least one link connected (link can be to another node or a TU on any sector). TU: on - connected to the node. |
| | Off | <ul style="list-style-type: none"> No link. |
| ETH1 | Green | <ul style="list-style-type: none"> Node: on - 10 GbE link. TU: on - 2.5 GbE link. |
| | Orange | <ul style="list-style-type: none"> Node: on - 5/2.5/1 GbE, 10/100 Mbps link. TU: on - 1 GbE, 10/100 Mbps link. |
| | Off | <ul style="list-style-type: none"> No link (carrier). |
| ETH2 (Node and T265-CCP only) | Green | <ul style="list-style-type: none"> On - 1 GbE link. |
| | Orange | <ul style="list-style-type: none"> On - 10/100 Mbps link. |
| | Off | <ul style="list-style-type: none"> No Link (carrier). |
| SFP (Node and T265-CCP only) | Green | <ul style="list-style-type: none"> On - 10 GbE link. |
| | Orange | <ul style="list-style-type: none"> On - 1 GbE link. |
| | Off | <ul style="list-style-type: none"> No Link (carrier). |



4.10 Link Up Verification

4.10.1 Node Checks

Perform the following checks on each node:

1. Verify that node sector 1 is pointing to the azimuth specified for the site.
2. Verify the self-locking bands are tightened.
3. Verify that the unit has been properly grounded.
4. Verify that the PWR LED is green.

4.10.2 TU Checks

Perform the following checks on each TU:

1. Point the TU towards the serving node (see [Section 4.7 - Mounting and Aligning the MultiHaul™ TG TU on a Pole or Wall](#)).
2. Verify the self-locking bands and the elevation lock bolts are tightened.



If you mounted the TU using the EH-MK-SM mounting kit, verify the elevation and azimuth lock bolts on the mounting kit are tightened.

3. Verify that the PWR LED is green.
4. Verify that the RF LED is green, indicating correct association with the serving node (Link Up).

4.10.3 Configuring the System

The MultiHaul™ TG units can now pass management and traffic between the units over the radio link, to/from the ethernet ports.

You can use the GUI or CLI for advanced configuration of the units, monitoring their status and troubleshooting.



4.11 Resetting the Unit



Resetting the unit causes all user configurations to be lost.

The MultiHaul™ TG unit includes a pushbutton next to the USB port on the connector panel under the unit, as shown and described below:

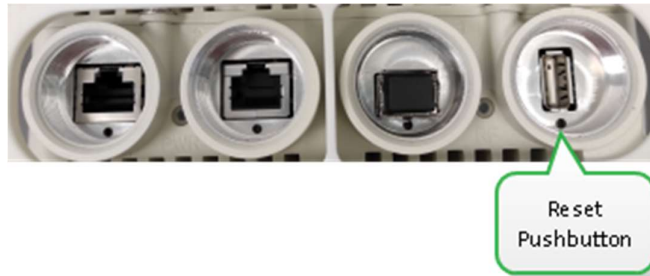

| Button | Description |
|--------|---|
| Reset | 10 second or more press - reset to factory default. |



5. Management Concepts

You can manage MultiHaul™ TG units using the Command Line Interface (CLI) only with the current SW version.

MultiHaul™ TG supports NETCONF and YANG to easily configure the units and extract data.

NETCONF is a protocol defined by the IETF to install, manipulate, and delete the configuration of network devices. NETCONF operations are realized on top of a Remote Procedure Call (RPC) layer using an XML encoding and provides a basic set of operations to edit and query configuration on a network device.

YANG is a data modeling language for the definition of data sent over NETCONF. It can be used to model both configuration data and state data of network elements.

4.1 Connecting to the CLI

To establish a CLI Session with the MultiHaul™ TG unit:

1. Use any SSH client program, such as PuTTY, available for download from the web.
2. Open an SSH session to the IP address of the unit (default = 192.168.0.1).

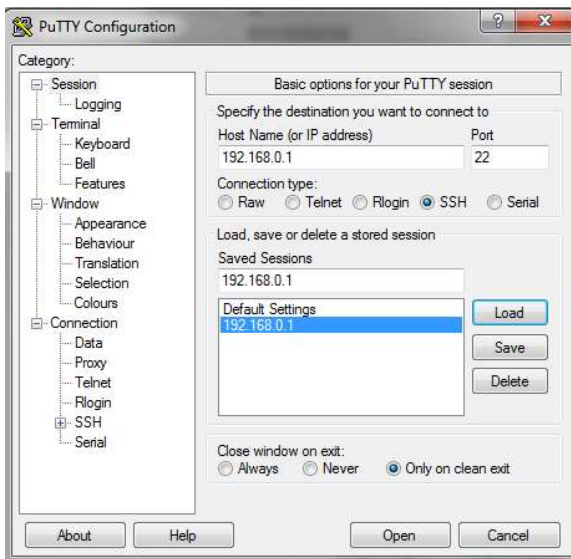

3. Configure PuTTY with the following recommended settings:
 - a. Under **Terminal > Keyboard**:
 - **The Backspace key** = Control-H
 - **The function keys and keypad** = Linux
 - b. Under **Window**:
 - **Set Lines of Scrollback** = 100000
4. Type a name under **Saved Sessions** and click **Save**. The session will be stored under the Saved Sessions.



Whenever you want to connect, click the saved session name then click Load.

5. After connecting, type the username and password. The default credentials are:

username: admin

password: admin

After you type your username, the prompt changes to [username]@[unit ip address]:



```
login as: admin
admin@31.168.34.110's password:
```



If you typed incorrect credentials, **Access denied** appears. If the password was incorrect, you can retype it. If the username was incorrect, disconnect and reconnect.

4.2 Configuring Management IPv4 Address \ Default Gateway

MultiHaul™ TG supports up to four IP addresses that can be on different subnets and associated with different VLANs.

The IP addresses and gateway are managed through the ip container as follows:

| Parameter | Mandatory | Values | Remarks |
|-----------|-----------|-----------------|---|
| ipv4 | ✓ | address | List of static IPv4 addresses, for management |
| | | default-gateway | Unit default IPv4 gateway |

To set management IPv4 addresses and a default gateway, type the following commands:



```
set ip ipv4 address 10.40.1.100 prefix-length 24
set ip ipv4 default-gateway 10.40.1.1
commit
```

To delete management IPv4 addresses and the default gateway, type the following commands:

```
delete ip ipv4 address 192.168.0.1
delete ip ipv4 default-gateway 10.40.1.1
commit
```

To show the management IP configuration, type the following command:

```
MH-N366>show ip ipv4
ipv4 {
  address {
    ip 31.168.34.110;
    prefix-length 29;
  }
  default-gateway 31.168.34.105;
}
```

