

# EH-600T Rev D0 Functional Description and Block Diagram



August , 2014

[www.siklu.com](http://www.siklu.com)

Updated September 2015

## 1. General Product Description

The **EtherHaul-600T** radio provides wireless point-to-point Gigabit Ethernet connectivity over the 57-64GHz unlicensed V-band spectrum. Optimized for small cell backhaul, it is designed to meet mobile service providers' stringent requirements for easily installed, high-capacity, carrier-grade backhaul solutions.

The **EH-600T** is based on Siklu's revolutionary integrated-silicon technology, which results in a highly reliable, zero footprint, and low-cost radio.

The **EH-600T** offers Gigabit throughput, MEF-compliant networking and QoS, enhanced Hitless Adaptive Bandwidth, Coding & Modulation for maximum spectral efficiency, and link availability. It supports network synchronization, advanced OAM&PM tools and ring protection optimized for small cell and mobile backhaul. It features multiple GbE interfaces, supporting complex network topologies, such as daisy chain, ring, and mesh and colocation installation. All in a very small and light outdoor package that is optimized for street level installations and designed to overcome pole sway, twist and/or tilt. The EH-600T is fast, simple and inexpensive to deploy.

EH-600T as the best solution for small cell backhaul features:

- Field proven technology
- Reduced TCO and fast ROI
- All-outdoor invisible footprint
  - Small and light
  - Quick and easy to install
- Optimized for street level deployment
  - Works on poles, walls, traffic lights and more
  - Designed to overcome sway, twist and/or tilt
- Spectrum efficiency
  - Hitless Adaptive Bandwidth Coding and Modulation for high availability
- Advanced layer-2 features:
  - MEF-compliant QoS
  - VLAN, Provider Bridge
  - SLA assurance
- Advanced AES encryption

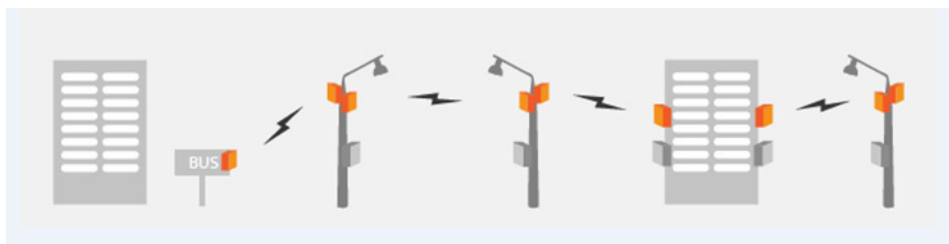

Figure 1 - Small cell deployment diagram

Easily integrated into provider or enterprise networks, out-of-the-box up & running capable, the EtherHaul products provides advanced carrier Ethernet features including cutting-edge, integrated Layer 2 switching and Ethernet OA&M capabilities. Highly-scalable, the EtherHaul products are software-upgradable to support future Layer 2.5/3 networking and routing capabilities as networks evolve to flat-IP topologies.

The EtherHaul products features advanced adaptive modulation, bandwidth and coding - allowing operators to maintain, prioritize, and verify QoS in all weather conditions, while achieving maximum (up to 99.999%) link availability.

Offering easy and low cost all-outdoor installation and a small form factor, the EtherHaul products are also environmentally-friendly - boasting a small system and antenna footprint, and especially low power consumption.

The EtherHaul systems are High-capacity Gigabit Ethernet backhaul, with advanced networking capabilities, at the lowest TCO in the industry. EtherHaul enables mobile operators to profitably and reliably provide data intensive services. Provided by Siklu, the pioneer in silicon based mm-waves backhaul systems, EtherHaul systems are the perfect choice for future proof investment.

## 2. EH-600T General Block Diagram

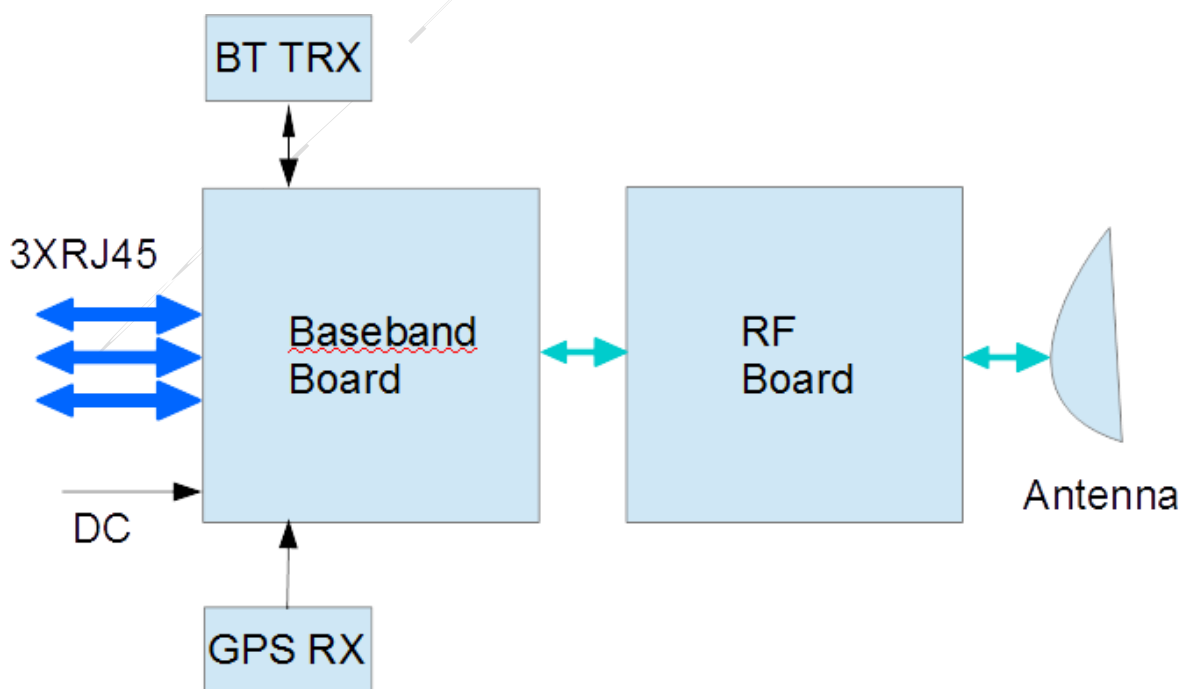

Figure 1: EH-600T Block Diagram