

The ZoneSafe System

User Manual

Document Name
ZoneSafe™ User Manual
Document Number
14/6784
Original Issue Date
17-07-2017

Contents

1	Introduction	4
2	What's in the Box	4
3	How the System Works	4
4	System Components	5
4.1	Control Unit	5
4.3	Tags	6
4.4	Driver Tag	6
4.5	Wireless Tag Charger	6
4.5.1	Wireless Charger Charging Instructions	7
4.6	TufTags	7
4.6.1	TufTag Installation	7
4.7	Plus Tag Tester	7
4.8	Fixing	8
4.8.1	AMPS	8
4.8.2	Adapter plates	8
5	System Operation	9
5.3	Configuration	9
5.3.1	Connection	9
5.3.2	Summary	9
5.1	On Sequence	9
5.2	Off Sequence	9
5.3.3	Configuration of Wi-Fi Profiles	10
5.3.4	Configuration of Event Upload Settings	10
6	Hardware Installation	10
6.1	Requirements	10
6.2	Installation Considerations	10
6.2.1	Antenna Mounting	10
6.2.2	Distance between Antennas	11
6.2.3	Optimum Tag Position	12
6.3	Control Unit	12
6.4	Antenna Unit	13
6.5	Tags	13
7	Example Installation	13
8	Connections	14
8.1	Control Unit	14
8.2	Antenna Unit	15
8.2.1	Antenna Connections	15
8.2.2	Antenna Switches	15
8.3	Hardware Setup & Test	15
8.3.1	Installation of Units	15
8.3.2	Confirm Antenna Range	16
8.3.3	System Monitoring	16
9	System Specification	16
9.1	Control Unit	16
9.2	Antenna Unit	16
9.3	Tags	17
9.4	Tag Tester	17
10	Troubleshooting	17
11	WEEE Directive	17
12	Disclaimer	17
13	Approvals	18
14	FCC Compliance Information	18
14.1	Applicable FCC IDs:	18
15.	Declarations of Conformity	19
15.1	Control Unit	19
15.2	Antenna Unit	20
15.3	Standard Tag	21
15.4	VibraTag	22
15.5	Plus Tag Tester	23

Issue No.	Date of Issue	Details of Changes
1	17/07/2017	Original Version
2	12/10/2017	updated images
3	12/10/2017	updated info
4	16/01/2018	DoC and FCC info added
5	23/01/2018	Added TufTag & Wireless Charger Information

Information in this document is subject to change without notice.
You do not have permission to reproduce, publish or share any part of this document either electronically or printed in part or full without prior written consent from Avonwood Developments Ltd.

1 Introduction

ZoneSafe is a proximity warning and alert system for minimising collision risks to workers and assets in a working environment.







The system uses Active RFID tags worn by workers or fitted to assets. These are detected when in close proximity and activate an audible visual alarm to indicate a risk to equipment operators.

The system is typically installed on to materials handling equipment, industrial lift equipment, support equipment and heavy plant.

Disclaimer:
As supplied the ZoneSafe system offers an indication to risk via audible and visual warnings only. ZoneSafe is not to be used as a protective device, initiate or perform safety related functions or take over control to prevent accidents.

2 What's in the Box

A standard system consists of:

Controller & Parts			Antenna & Parts		
		Cable Loom & Connector for Controller			M16 Blanking Plug (Note - part comes with controller)
		Inline Fuse Holder x2 per unit			M4 x 35mm Hex Screw x6 per unit
		7.5 Amp Blade Fuse x2 per unit			6 Way Screw Terminal x2 per unit

Please note - tags are required for each ZoneSafe system to work. These are purchased separately.



3 How the System Works

ZoneSafe is a tag based system using active radio frequency identification (RFID) technology. The system comprises of an in-cab control unit with either single or multiple antenna units installed onto equipment, and active tags worn by workers or fitted to assets.

Three groups of active RFID tags are available, Driver Tags, Pedestrian Tags and Tuf Tags. A number of tag options are available within these groups.

Antenna units installed on the equipment produce a 360° detection zone. This is user configurable and can be set to detect tags from a range of 3m to 9m distance. Using antenna units either single, multiple or overlapping detection zones can be set up and configured depending on vehicle type and detection requirements.

Driver tags are placed into a tag holder located on the top of the control unit when the machine is operational. This enables the drivers tag to be logged and prevent it from being detected. If a driver tag is not inserted in the holder, an audible alarm will sound.

When a pedestrian tag or asset tag enters the 3m to 9m detection zone, an audible and visual alarm is activated from the in-cab control unit indicating to the equipment operator that a tagged person or asset is in close proximity to the vehicle.

The system maintains an event log and stores up to 4000 individual events. Events can be viewed either using an internet browser connected to the control unit via Wi-Fi direct or by automatic upload via a Wi-Fi access point at my.zonesafe.net.

NOTE:
ZoneSafe must be fitted and commissioned by an approved installer. No responsibility will be accepted for damage to systems caused by incorrect installation or misuse.

Detection accuracy will depend on environmental and installation factors.

4 System Components

The ZoneSafe system comprises of the following standard components and accessories:
(for a more comprehensive range of our products please contact our sales team)

Standard Components

1. Control Unit
2. Antenna Unit
3. Standard Driver Tag - sold separately
4. Standard Pedestrian Tag - sold separately

Accessories (including but not limited to)

1. Plus Tag Tester (Tag battery level testing)
2. TufTag (Cone mounted tag for tagging assets)
3. VibraTag (Vibrating tag)
4. Fixing Plates (Installation)
5. Cloud Software (Identify, monitor and improve areas of risk such as near miss occurrences throughout your work site)

4.1 Control Unit

The Control unit provides the overall functionality of the system and acts as the user interface. The unit contains a battery backed real-time clock for precisely logging tag detect events, internal memory to store event data and a Wi-Fi interface for communication. A relay is available for additional external sounders or beacons.

The Control unit is mounted in the driver cab next to the operator so it can be clearly visible at all times. Audible alerts are emitted from a sounder located on the front, a light panel and button create visual alerts and indicate various alarm states. The button can be configured to acknowledge the detection of one or more tags.

The table of alarms indicates the types of alarms that the control unit will highlight. The alarm state demonstrates each alarm colour sequence (note- black indicates the light is off).



Priority	State	Alarm Colour	Alarm State	Sounder	Button Colour
1	2+ Pedestrian	Red (Flash)		Two Tone Fast	Red
2	1 Pedestrian	Red (Flash)		Two Tone Slow	Red
3	Reserved	x	x	x	x
4	System Error	Pink (Flash)		System Beep	Red
5	No Ignition	Red (Pulse)		One Tone	Red
6	No Driver Tag	Red (Pulse)		One Tone	Red
7	WiFi Connected	Blue (Pulse)		x	Green
8	Ok	x	x	x	Green

4.2 Antenna Unit

The Antenna Unit creates a detection zone around the vehicle or asset. Antennas should be fitted at appropriate locations to provide the optimum detection zone required (see 6.2.1 Antenna Mounting).

Antenna units are linked (in series) to the system Control Unit. The number of antennas required depends on the size of the vehicle and detection zone around it. Each antenna detection zone can be adjusted between 3 - 9 metres (see 8.2.2 Antenna Switches).



4.3 Tags

Tags are worn by all personnel. When a tag enters the detection zone around a vehicle or asset, a visual and audible alarm is provided from the in cab control unit to warn the machine operator. Each tag is factory configured with a unique ID and can be used on any ZoneSafe enabled job site.

Tags within the proximity of a detection zone will be logged by the control unit. The data logged from the tag includes its unique ID, date/time and battery status.



4.4 Driver Tag

A Driver Tag is required for the driver of the vehicle and for the system to work. The tag is placed into the Control Unit (see 5.1 On Sequence), which not only arms the system but also masks itself from the antenna. If the vehicle is started, and there is no tag present, the control unit will automatically alarm emitting the no tag alarm tone. The driver must take the tag with them when they exit the vehicle.



NOTE: It is essential that all personnel on the work site wear a tag.

4.5 Wireless Tag Charger

The wireless tag charger is used to charge any style of ZoneSafe rechargeable tag such as the VibraTag by simply connecting the charger via the mini USB cable to a power source and placing the tag on top of the charging pad. For further information, please see the following section.



4.5.1 Wireless Charger Charging Instructions

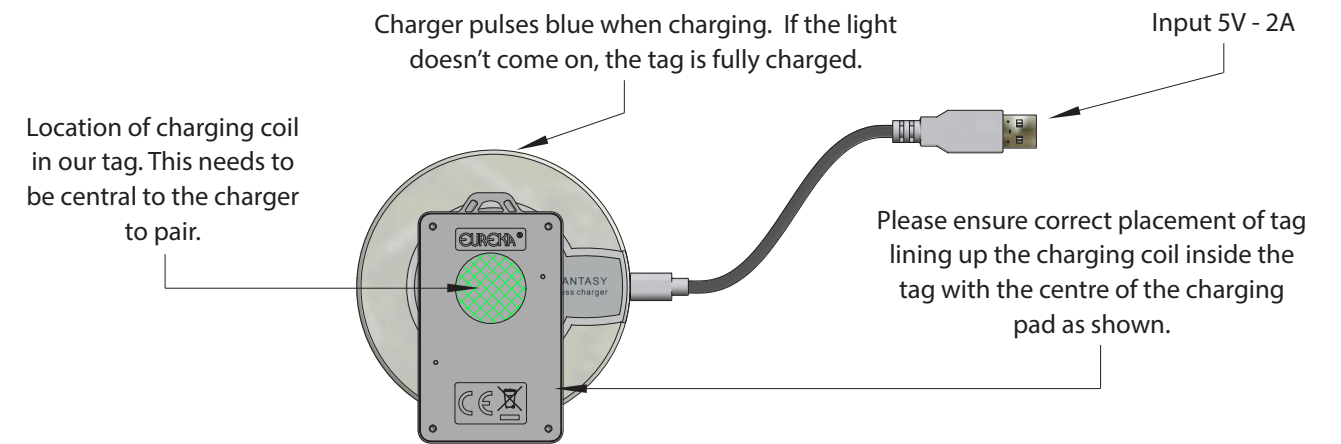

4.6 TufTags

TufTag is our cone mounted active tag and integrates seamlessly with our ZoneSafe proximity warning systems. Designed to protect static assets, the TufTag can be used in any situation where a vehicle operator needs to be alerted to a potential hazard.



4.6.1 TufTag Installation

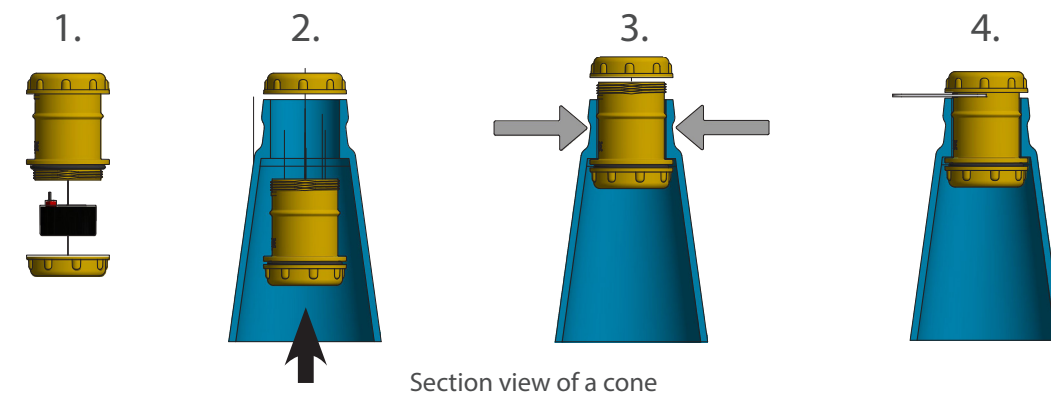

1. Connect and fit the battery and tighten the cap.
2. Take off the top cap and fit the tag through the neck of the cone from the inside. Hold the cone horizontally and extend your arm to help push it through the neck or place on top of another cone to push the tag through.
3. Squeeze the neck of the cone and screw the top cap on.
4. Tighten the top cap with the card spanner tool.

4.7 Plus Tag Tester

The Plus Tag Tester provides an easy way to test the status of any ZoneSafe / Eureka tag. We recommend personnel check their tag battery status daily before entering the job site. The unit reads a tag and displays the status of the battery using indicator LEDs. Daily use of the tag test unit ensures tag batteries are always in a serviceable condition.



Indicator LED's include:

- Blue Flash - Indicates The Plus Reader is turned on
- Quick Blue Flash - Indicates the reader has identified the tag
- Green Light - Indicates tag battery is good
- Red Light - Indicates low tag battery

4.8 Fixing

For fixing of the Controller and the Antenna, use the AMPS configuration fixings on the back of the devices or use one of the adapter plates.

4.8.1 AMPS

Both the in-cab control unit and antenna have M5 threaded inserts in the AMPS configuration on the rear. Engagement depth of machine screw must not exceed 8mm.

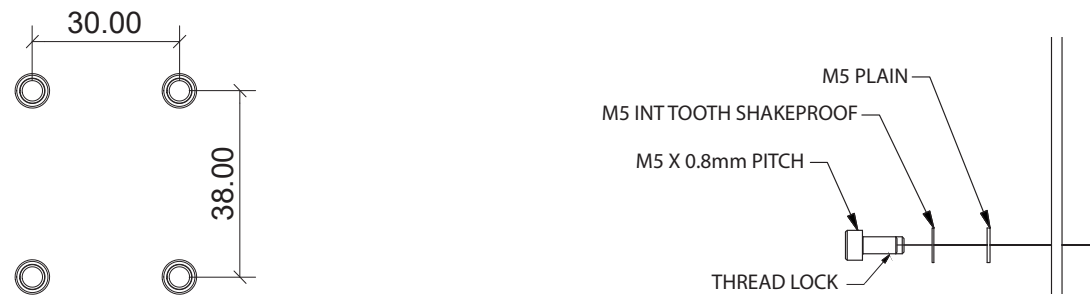

You can use the hole configuration to attach a 1.5" Ball RAM Mount base and any configuration of RAM mount fixtures. Holes can be made directly on the vehicle and fixing can be done from the back through the vehicle body and into the fixings. Thread lock and shake-proof washers are recommended - always fasten securely but do not over-tighten.

4.8.2 Adapter plates

An adapter plate is available for the Control unit and the Antenna. This fixes to each unit via four countersunk M5 screws with thread lock.

The adapter plates provide four legacy holes for customers who want to use the existing holes they made following a previous ZoneSafe system installation. The plates also provide slots top and bottom which are large enough for M8 fixings.

The method for attaching the Control unit will vary from vehicle to vehicle, if the adapter plate is to be used then the slots allow for front fixing or as an example a U bolt clamp can be fastened to them.



'D' Adapter Plate fitted to Controller Unit

'A' Adapter Plate fitted to Antenna

Exhaust 'U' Bolt Clamp fitted to Controller Unit

5 System Operation

5.1 On Sequence

- Place the driver tag into the slot
- Turn the vehicle ignition ON to initialise the system
- If the Push Button LED = GREEN then the system is operational (for any other indication see the alarm table)



- Detection Zone is now ACTIVE

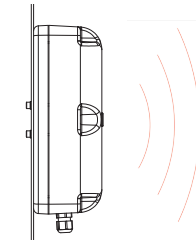

NOTE: If the ignition remains on and no driver tag is in detected in the holder for a period of time, the "No Driver Tag" alarm will be raised. This is intended to prevent the vehicle being operated by an un-authorized driver.

5.2 Off Sequence

- Turn the vehicle ignition OFF
- Remove the driver tag from the holder
- Button LED turns off

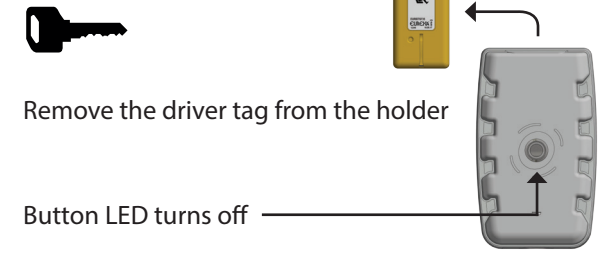

- Detection Zone is now INACTIVE

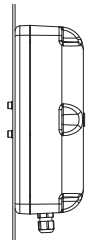

NOTE: If the ignition is off and the driver tag remains left in the holder for a period of time, the "No Ignition" alarm will be raised. This is intended to remind the driver to take the tag when leaving the vehicle.

5.3 Configuration

The ZoneSafe Wi-Fi Controller can automatically connect to Wi-Fi infrastructure networks and upload ZoneSafe event data to the ZoneSafe Insight website. The Wi-Fi connection also permits a direct connection to allow configuration and monitoring of the device via its integral Web Server.

5.3.1 Connection

The ZoneSafe Wi-Fi Controller broadcasts a SSID of ZoneSafe_XXXXXX where XXXXXX is the device's serial number, as printed on the product label. From your device, view available Wi-Fi connections and select this network and click Connect. Enter the default security key "ZONESAFE" and click OK

When the connection has been established open a web browser and enter URL <http://192.168.0.1/> This is the address of the ZoneSafe Wi-Fi Controller. When prompted for credentials, enter the default user name "admin" and password "PASSWORD".

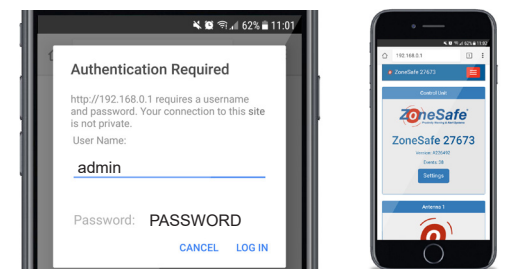

5.3.2 Summary

The Summary page displays the Control Unit and a separate box for each of the configured antennas. Click the Settings button on the respective unit to open the configuration page for this unit.

5.3.3 Configuration of Wi-Fi Profiles

It is highly recommended to add at least one Wi-Fi network profile to your ZoneSafe device to allow automatic event uploading and remote monitoring. The ZoneSafe Wi-Fi Controller can store up to 4 Wi-Fi network profiles that it will automatically connect to.

Click WI-FI from the menu. The device will perform a scan of Wi-Fi networks and display the list of networks found in order of signal strength. Click the Add button on the row for the network you wish to add and enter the network passphrase when prompted. Click Delete to remove the profile from the device.

5.3.4 Configuration of Event Upload Settings

Click Admin – Upload Settings from the menu.

The Upload Interval is specified in seconds. Set this value to zero to disable event uploading. After entering the required value, click the Save button to apply the changes.

The other settings should only be changed under instruction from Avonwood Developments.

6 Hardware Installation

Before installation please read the following guide lines to ensure that the system is correctly installed and provides optimum performance.

NOTE: We recommend the installation of ZoneSafe™ is carried out by a fully authorised ZoneSafe™ installatio engineer.

The ZoneSafe Control Unit must be installed to be at least 20cm away from any person when in normal use.

6.1 Requirements

- 12V or 24V DC battery supply (protected by a 7.5A anti-surge fuse)
- 0V Earth location
- 12V or 24V DC ignition supply (protected by a 7.5A anti-surge fuse)
- Cable & tools

6.2 Installation Considerations

6.2.1 Antenna Mounting

- Antennas can be mounted vertically (best) or horizontally. For vertically mounted antennas in high positions, angle unit downwards

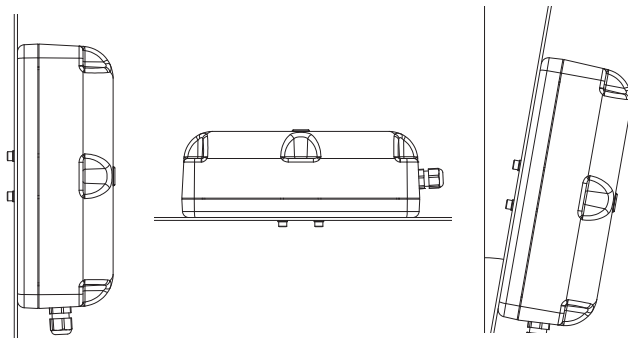

- No metal should be within 200mm of the top, bottom and sides of the antenna.
- No metal should be in front of the wakeup antenna, for example a grille.

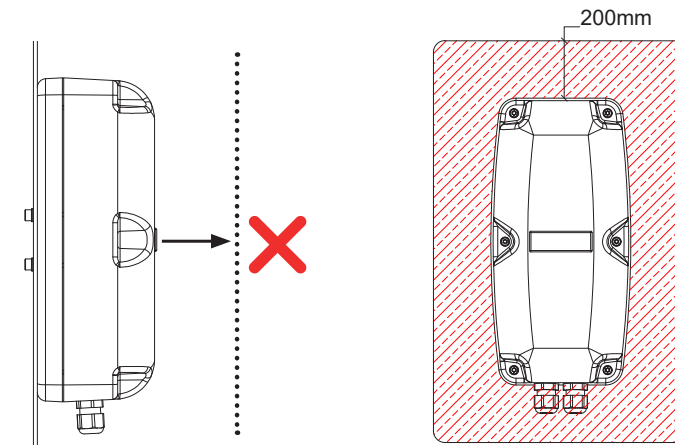

6.2.2 Distance between Antennas

Choose the size of the detection zone prior to fitting the system to the machine/object. The distance between antennas should equal the detection zone minus 20%. Use the table to help set up an optimum detection zone. This setup will help reduce lobe effects and provide an optimum detection zone.

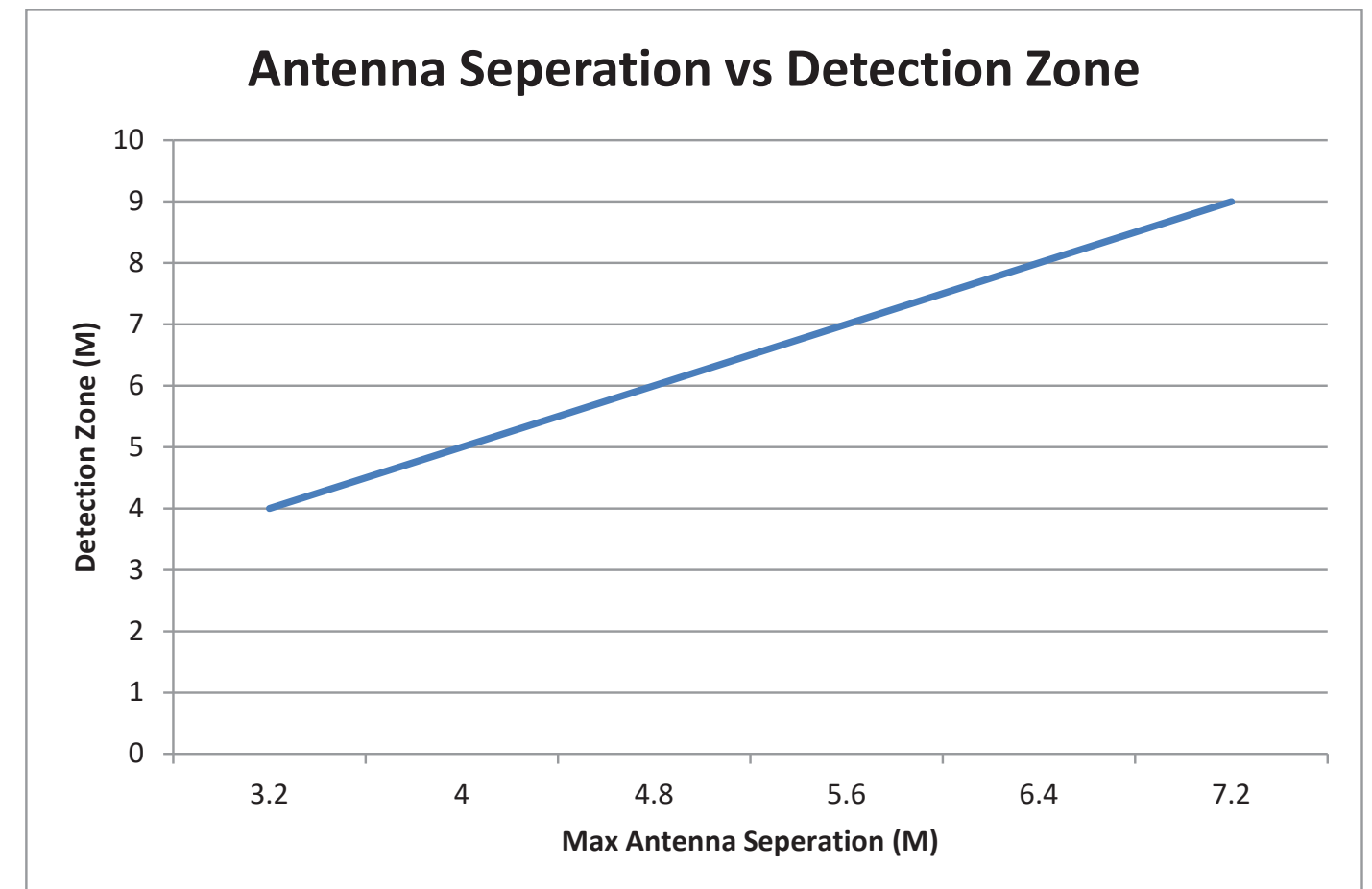

6.2.3 Optimum Tag Position

The optimum detection range of the tag can be achieved when the tag and wakeup antenna are level to each other. Changing the angle of the antenna can overcome high mounting issues, but may reduce the effective read range.

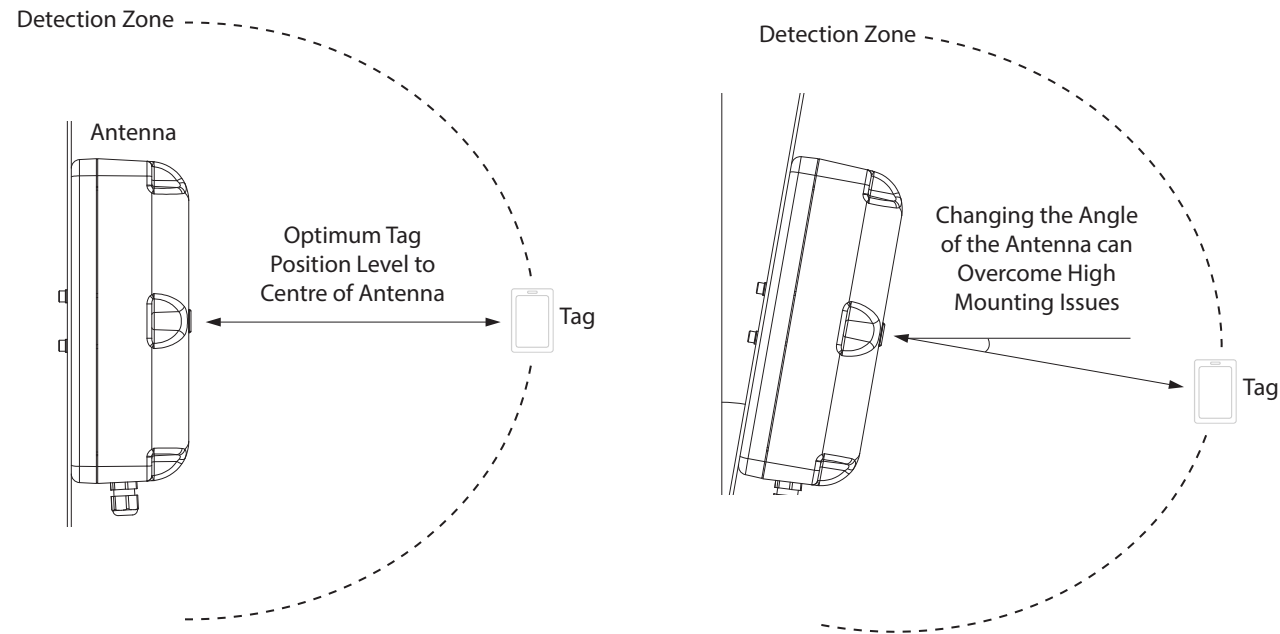

6.3 Control Unit

The Control Unit should be located within the machine operator's view and reach, but must not restrict the operator's view of the working area or any operational controls. The Control Unit must not be located within 75cm of an Antenna Unit. The unit should preferably be installed in a vertical position or in clockwise tilt to allow water to freely drain.

Should you need to remove the tamper cover located at the bottom of the control unit covering the cable loom and connection, please follow the instructions below.

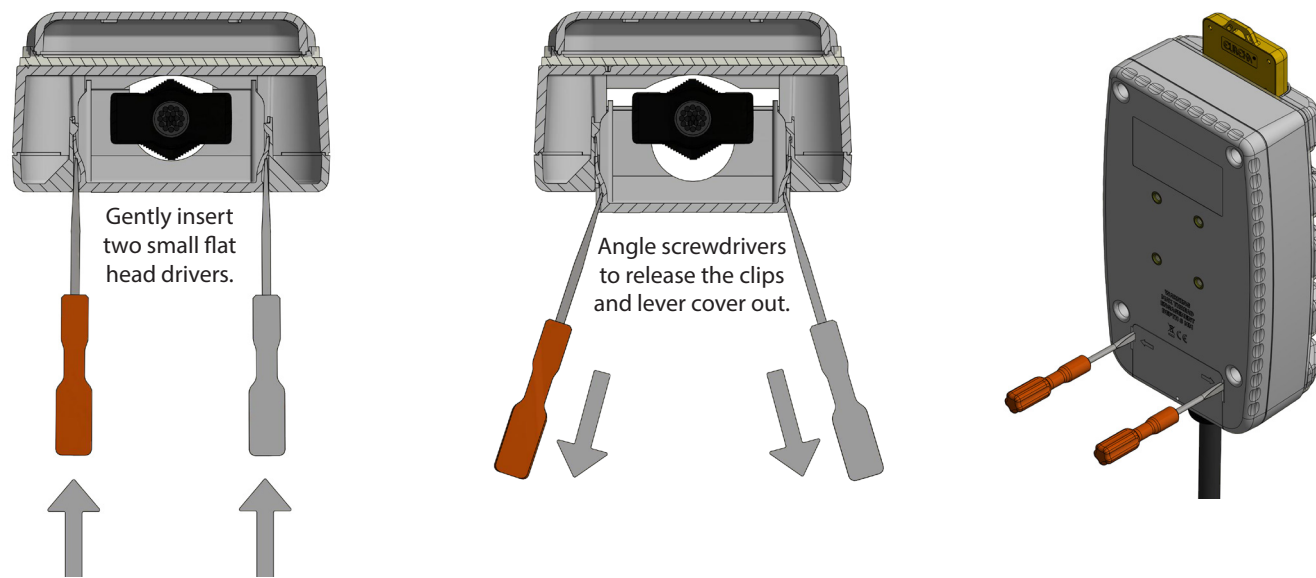

6.4 Antenna Unit

Identify suitable locations for the Antenna Units and install the wiring loom from the Control Unit to the first Antenna Unit location. Then install the wiring from the first antenna location to the second antenna location, then the second location to third location etc.

The incoming power and data cable from the Control Unit enters via one cable gland and leaves via the other cable gland to the next Antenna Unit in series.

6.5 Tags

Tags should be worn or attached vertically if possible to ensure best detection range. Tags can be worn using a lanyard, a belt clip add on, an armband or integrated into PPE such as a high visibility vest. All personnel on the job site must wear a working tag in order to be picked up by our system.

7 Example Installation

Depending on the size and shape of the vehicle, more than one antenna may need to be fitted to provide a well defined detection zone. Below illustrates a range of different vehicle types with at least one antenna fitted to each vehicle. The larger the vehicle, the more antennas will need to be fitted to create an adequate detection zone around the vehicle. Antennas can also be fitted to moving parts such as the boom or dipper arm of a vehicle to create a moving detection zone.

One Antenna System Fitted to Forklift Truck

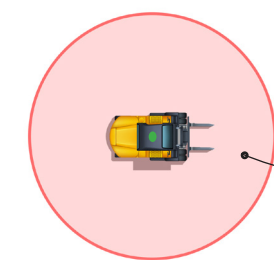

Two Antenna System Fitted to Bulldozer

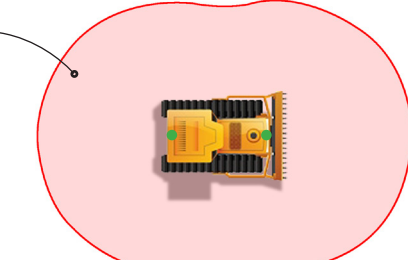

Four Antenna System Fitted to Shovel Loader

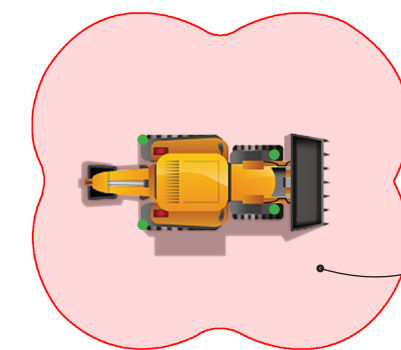

Five Antenna System Fitted to Excavator with Antenna Fitted to Digger Arm

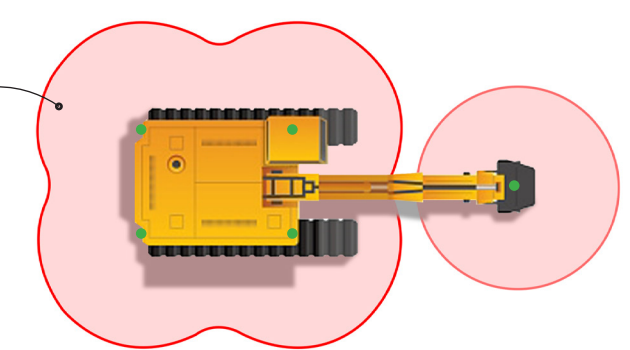

● Antenna Location (Approx)

8 Connections

NOTE: For 12V systems with long cable runs, a separate supply may be required to the Control Unit and each Antenna Unit.

IMPORTANT: Ensure power is isolated & vehicle ignition is OFF before making connections.

8.1 Control Unit

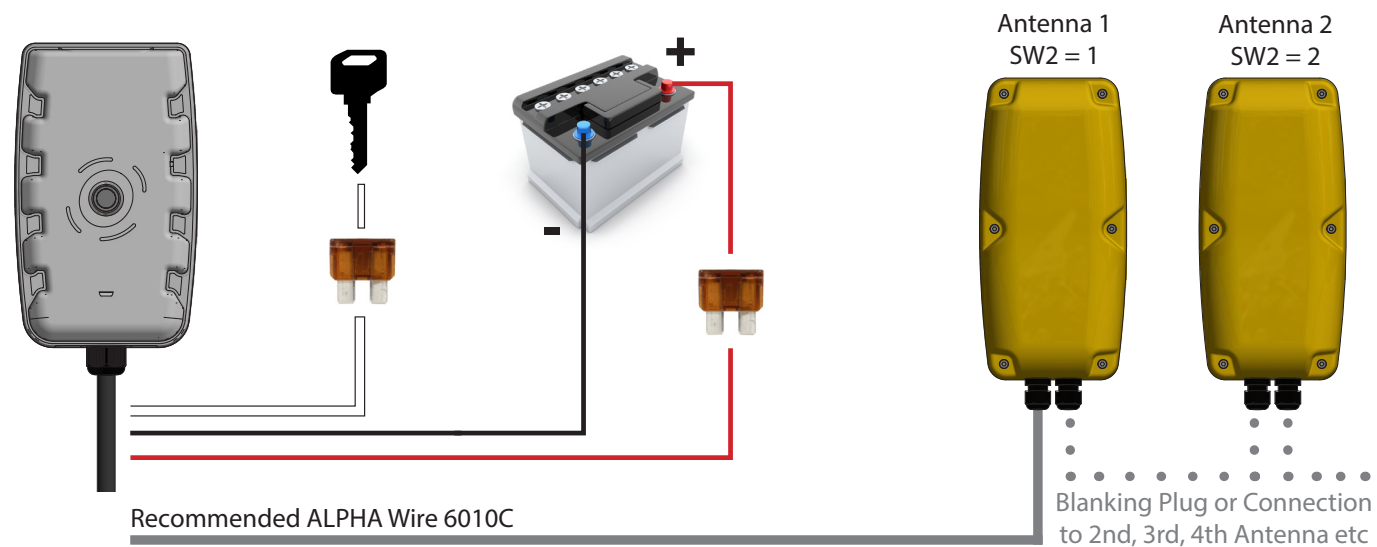

Mandatory Wiring:

Description	Colour	To
VBAT_IN	Red	Vehicle battery +ve
0V_IN	Black	Vehicle battery 0V
VIGN_IN	White	Vehicle ignition +ve
0V_OUT	Red/Brown	Wakeup CONN2/1
VIGN_OUT	Red/Black	Wakeup CONN2/2
SYNC_B	Violet	Wakeup CONN2/3
SYNC_A	Yellow/Red	Wakeup CONN2/4
RS485_B	Yellow	Wakeup CONN2/5
RS485_A	Green/Red	Wakeup CONN2/6

Optional Wiring:

Description	Colour
IN2+	Pink
IN1+	Blue
IN2-	Green
RL_NC	Orange
RL_NO	Brown
IN3+	Turquoise
IN3-	Grey
IN1-	Red/Blue
RL_COM	White/Red

8.2 Antenna Unit

Antenna Units are linked together using the IN and OUT 6 way headers, CONN2 and CONN3.

- Cable: 3 pair individually screened, Core: 7/0.2 (i.e. Belden 8777, Alpha 6010C, Cable Hub/ FS cables 2203PIFRD)

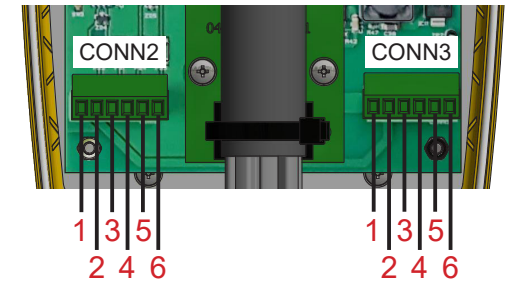

8.2.1 Antenna Connections

Pin numbering and descriptions for CONN2 and CONN3 are identical. CONN2 can be used for the outgoing cable and CONN3 for the incoming cable or vice-versa.

Wiring:

CONN2/3 Pin Number	Description	Colour*
1	0V_IN	Black/Red
2	VIGN_IN	Red
3	SYNC_B	Black/White
4	SYNC_A	White
5	RS485_B	Black/Green
6	RS485_A	Green

*Wiring Colours Based on Alpha Wire 6010C

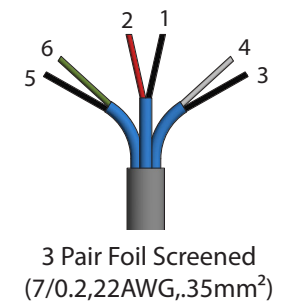

8.2.2 Antenna Switches

Locate SW1, SW2 & SW3 inside antenna unit.

Using a trim tool or a small flat bladed screw driver, turn SW1 clockwise to increase power or anticlockwise to decrease power. Set SW1 to give the desired tag detection range.

SW2 – ADDRESS (1=first antenna unit: must be numbered sequentially to the last)

SW3 – SYNC (OFF=external (driven from controller) ON=internal)

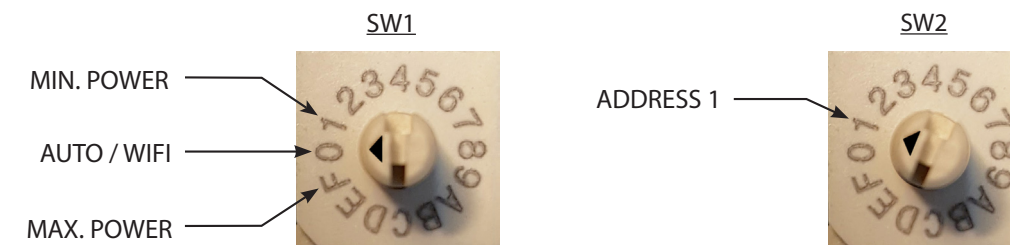

8.3 Hardware Setup & Test

8.3.1 Installation of Units

Connect Control Unit and Antenna Unit cables before connecting to vehicle systems. Make sure switches SW1 to SW3 are set on the Antenna Units as described in the previous section.

8.3.2 Confirm Antenna Range

Using an LED Test Tag (supplied separately), walk around the detection zone that has been set. An LED on the test tag will illuminate when it is in the detection zone providing a visual illustration of the zone. The LED on the test tag may pulse but should not be off for more than 1 second. As necessary, adjust TX power on each Antenna Unit to alter the size of the detection zone. If one or more Antenna Units are installed incorrectly they can oppose each other and detection free zones may exist.

8.3.3 System Monitoring

The system continuously monitors data communication & status from each Antenna Unit while in operation.

9 System Specification

9.1 Control Unit

ZoneSafe Control Unit		
Electrical	Voltage Current Consumption Memory	12V - 24V DC nom (11-32V max) 1A max 4000 Events
Mechanical	Dimensions (incl. glands) Material Weight Connectors Relay (for additional sounders / beacons) Digital Input	180mm x 102mm x 58mm ABS 0.5kg IP D-type N/O N/C 0.5A @125VAC, 2A@ 30VDC 3 x Opto-Isolated inputs
Communications	Wi-Fi	IEEE 802.11b/g/n (2.4GHz)
Environment	Ingress Protection Temperature	IP65 -10°C to +50°C



9.2 Antenna Unit

ZoneSafe Antenna Unit		
Electrical	Voltage Current Consumption	12V - 24V DC nom (11-32V max) 2A max
Mechanical	Dimensions (incl. glands) Material Weight Connectors Mounting	245mm x 105mm x 90mm ABS / PC 1.4kg Nylon Glands AMPS Configuration
Communications	Wired	RS485
Environment	Ingress Protection Temperature	IP67 -10°C to +50°C
Radio	TX Frequency RX Frequency Range	125kHz 868.3MHz TX: adjustable 3-9m approx RX: 50m typ



9.3 Tags

Contact our sales team for a more comprehensive guide to our range of tags. All our tags are hermetically sealed to withstand the harshest environments.

9.4 Tag Tester

See Plus Tag Tester Manual 14/6667 for more information

10 Troubleshooting

Description	Diagnosis	Solution
Alarm does not mute.	More than one tag in detection zone.	Check detection zone for all tags.
With driver tag and ignition on, there is a constant tone.	Wiring fault on ignition.	Check ignition and power is connected correctly.
With no tag in the zone, the alarm still pulses.	Driver tag is being detected.	Contact a qualified installation engineer, check driver search time and masking field.
Alarm goes off in certain locations.	Tag detection.	Is there a tag behind a wall, on the second floor or behind an obstacle?
All vehicles in the area alarm at the same time.	Vehicle ID (wakeup address) is the same.	Using Zonesafe software change wakeup address.
Why is the alarm a constant tone when leaving the vehicle?	Driver tag left in holder.	Remove driver tag.

If a fault cannot be identified in the above table, or the solution does not resolve your fault, please contact your Zonesafe qualified installation engineer. It is the responsibility of the end user to keep a record of unique vehicle wake up ID if altered from the manufacture supplied ID.

11 WEEE Directive

The Waste Electrical and Electronic Equipment Directive (WEEE Directive) was introduced into UK law in January 2007 by the Waste Electronic and Electrical Equipment Regulations 2006.

This product shall not be treated as household waste. It must be treated in accordance with the Waste Electronic and Electrical Equipment Regulations 2006.

Avonwood Developments Limited is a WEEE registered producer WEE/EFO483SX.

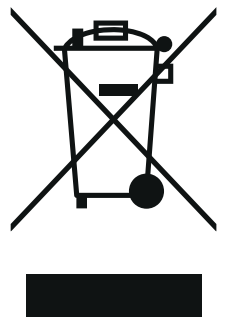

12 Disclaimer

The ZoneSafe™ proximity warning systems manufactured by Avonwood Developments Limited are supplied as an audible and/or visual alert system only. The ZoneSafe™ proximity warning system is not a protective device, it does not initiate or perform safety related functions and it does not provide control to reduce risk.

ZoneSafe™ should not be used to replace proper job site organisation, safeguards, operator training and the application of

relevant vision standards that addresses safety and the safety of people on job sites.

Due to the nature of radio frequency, wireless communications and possible interference, data can never be guaranteed. Data can be corrupted, have errors or be totally lost. Avonwood Developments Limited ZoneSafe™ systems should not be used in situations where failure to transmit or receive data could result in damage of any kind to the user or any other party, including but not limited to personal injury, death or loss of property. Avonwood Developments Limited accepts no responsibility for damages of any kind resulting from errors in data transmitted or received using Avonwood's ZoneSafe™ systems, or for the failure of the Avonwood's ZoneSafe™ systems to transmit or receive such data.

Avonwood Developments Limited accepts no liability for any and all direct, indirect, special, general, incidental, consequential, punitive or exemplary damages including, but not limited to, loss of profits or revenue or anticipated profits or revenue arising out of the use or inability to use any Avonwood Developments Limited products.

Information in this document is subject to change without notice.

13 Approvals

(a) For a Class A digital device or peripheral, the instructions furnished the user shall include the following or similar statement, placed in a prominent location in the text of the manual:

NOTE: This equipment has been tested and found to comply with the limits for a Class A digital device, pursuant to part 15 of the FCC Rules. These limits are designed to provide reasonable protection against harmful interference when the equipment is operated in a commercial environment. This equipment generates, uses, and can radiate radio frequency energy and, if not installed and used in accordance with the instruction manual, may cause harmful interference to radio communications. Operation of this equipment in a residential area is likely to cause harmful interference in which case the user will be required to correct the interference at his own expense.

This device complies with part 15 of the FCC Rules. Operation is subject to the following two conditions: (1) This device may not cause harmful interference, and (2) this device must accept any interference received, including interference that may cause undesired operation.

14 FCC Compliance Information

Note: This equipment has been tested and found to comply with the limits for a Class A digital device, pursuant to part 15 of the FCC Rules. These limits are designed to provide reasonable protection against harmful interference when the equipment is operated in a commercial environment. This equipment generates, uses, and can radiate radio frequency energy and, if not installed and used in accordance with the instruction manual, may cause harmful interference to radio communications. Operation of this equipment in a residential area is likely to cause harmful interference in which case the user will be required to correct the interference at his own expense.

Changes or modifications to ZoneSafe™ systems not expressly approved by Avonwood Developments Limited may void the user's authority to operate the equipment.

The ZoneSafe Control Unit must be installed to be at least 20cm away from any person when in normal use.

14.1 Applicable FCC IDs:

ZoneSafe Control Unit	2ACWNZSR6783
ZoneSafe Antenna Unit	2ACWNZSA6782
VibraTag	2ACWNZST6687
Standard Tag	2ACWNZS6277

15. Declarations of Conformity

Over the following pages you will find Declarations of Conformity for each piece of equipment in The ZoneSafe Manual.

15.1 Control Unit

EU Declaration of Conformity (DoC)

We,

Company Name: Avonwood Developments Ltd

Address: Knoll Technology Centre, Stapehill Road,
Wimborne, Dorset. BH21 7ND

Declare that the DoC is issued under our sole responsibility and belongs to the following product:

Product: ZoneSafe Standard Control Unit

Part Number: ZSR6783-EU

The object of the declaration described above is in conformity with the relevant Union harmonisation legislation:

Radio Equipment Directive 2014/53/EU

The following harmonised standards and technical specifications have been applied:

Reference & Date	Title
EN 300 220-2 V3.1.1 (2017-02)	Short Range Devices (SRD) operating in the frequency range 25 MHz to 1 000 MHz
EN 300 330 V2.1.1 (2017-02)	Short Range Devices (SRD); Radio equipment in the frequency range 9 kHz to 25 MHz and inductive loop systems in the frequency range 9 kHz to 30 MHz
Draft EN 301 489-1 V2.2.0 (2017-03)	ElectroMagnetic Compatibility (EMC) standard for radio equipment and services
Draft EN 301 489-3 V2.2.1 (2017-03)	ElectroMagnetic Compatibility (EMC) standard for radio equipment and services
Draft EN 301 489-17 V3.2.0 (2017-03)	ElectroMagnetic Compatibility (EMC) standard for radio equipment and services

Signed for and on behalf of: Avonwood Developments Ltd

Place of issue: Knoll Technology Centre

Date of issue: 16th January 2018

Name: Adrian Nash

Position: Engineering Manager

Signature:



15.2 Antenna Unit

EU Declaration of Conformity (DoC)

We,

Company Name: Avonwood Developments Ltd
 Address: Knoll Technology Centre, Stapehill Road,
 Wimborne, Dorset. BH21 7ND

Declare that the DoC is issued under our sole responsibility and belongs to the following product:

Product: ZoneSafe Antenna Unit
 Part Number: ZSA6782-EU

The object of the declaration described above is in conformity with the relevant Union harmonisation legislation:

Radio Equipment Directive 2014/53/EU

The following harmonised standards and technical specifications have been applied:

Reference & Date	Title
EN 300 220-2 V3.1.1 (2017-02)	Short Range Devices (SRD) operating in the frequency range 25 MHz to 1 000 MHz
EN 300 330 V2.1.1 (2017-02)	Short Range Devices (SRD); Radio equipment in the frequency range 9 kHz to 25 MHz and inductive loop systems in the frequency range 9 kHz to 30 MHz
Draft EN 301 489-1 V2.2.0 (2017-03)	ElectroMagnetic Compatibility (EMC) standard for radio equipment and services
Draft EN 301 489-3 V2.2.1 (2017-03)	ElectroMagnetic Compatibility (EMC) standard for radio equipment and services
Draft EN 301 489-17 V3.2.0 (2017-03)	ElectroMagnetic Compatibility (EMC) standard for radio equipment and services

Signed for and on behalf of: Avonwood Developments Ltd

Place of issue: Knoll Technology Centre

Date of issue: 16th January 2018

Name: Adrian Nash

Position: Engineering Manager

Signature:



15.3 Standard Tag

EU Declaration of Conformity (DoC)

We,

Company Name: Avonwood Developments Ltd
 Address: Knoll Technology Centre, Stapehill Road,
 Wimborne, Dorset. BH21 7ND

Declare that the DoC is issued under our sole responsibility and belongs to the following product:

Product: Standard Tag
 Part Number: ZST6735-EU

The object of the declaration described above is in conformity with the relevant Union harmonisation legislation:

Radio Equipment Directive 2014/53/EU

The following harmonised standards and technical specifications have been applied:

Reference & Date	Title
EN 300 220-2 V3.1.1 (2017-02)	Short Range Devices (SRD) operating in the frequency range 25 MHz to 1 000 MHz
EN 300 330 V2.1.1 (2017-02)	Short Range Devices (SRD); Radio equipment in the frequency range 9 kHz to 25 MHz and inductive loop systems in the frequency range 9 kHz to 30 MHz
Draft EN 301 489-1 V2.2.0 (2017-03)	ElectroMagnetic Compatibility (EMC) standard for radio equipment and services
Draft EN 301 489-3 V2.2.1 (2017-03)	ElectroMagnetic Compatibility (EMC) standard for radio equipment and services
Draft EN 301 489-17 V3.2.0 (2017-03)	ElectroMagnetic Compatibility (EMC) standard for radio equipment and services

Signed for and on behalf of: Avonwood Developments Ltd

Place of issue: Knoll Technology Centre

Date of issue: 16th January 2018

Name: Adrian Nash

Position: Engineering Manager

Signature:



15.4 VibraTag

EU Declaration of Conformity (DoC)

We,

Company Name: Avonwood Developments Ltd
 Address: Knoll Technology Centre, Stapehill Road,
 Wimborne, Dorset. BH21 7ND

Declare that the DoC is issued under our sole responsibility and belongs to the following product:

Product: VibraTag Series
 Type Designations: ZST6687-EU-P VibraTag – Pedestrian (EU)
 ZST6687-EU-D VibraTag – Driver (EU)
 ZST6687-EU-RP Rechargeable Tag – Pedestrian (EU)
 ZST6687-EU-RD Rechargeable Tag – Driver (EU)

The object of the declaration described above is in conformity with the relevant Union harmonisation legislation:
 Radio Equipment Directive 2014/53/EU

The following harmonised standards and technical specifications have been applied:

Reference & Date	Title
EN 300 220-2 V3.1.1 (2017-02)	Short Range Devices (SRD) operating in the frequency range 25 MHz to 1 000 MHz
EN 300 330 V2.1.1 (2017-02)	Short Range Devices (SRD); Radio equipment in the frequency range 9 kHz to 25 MHz and inductive loop systems in the frequency range 9 kHz to 30 MHz
Draft EN 301 489-1 V2.2.0 (2017-03)	ElectroMagnetic Compatibility (EMC) standard for radio equipment and services
Draft EN 301 489-3 V2.2.1 (2017-03)	ElectroMagnetic Compatibility (EMC) standard for radio equipment and services
Draft EN 301 489-17 V3.2.0 (2017-03)	ElectroMagnetic Compatibility (EMC) standard for radio equipment and services

Signed for and on behalf of: Avonwood Developments Ltd

Place of issue: Knoll Technology Centre
 Date of issue: 16th January 2018
 Name: Adrian Nash
 Position: Engineering Manager

Signature:



15.5 Plus Tag Tester

EU Declaration of Conformity (DoC)

We,

Company Name: Avonwood Developments Ltd
 Address: Knoll Technology Centre, Stapehill Road,
 Wimborne, Dorset. BH21 7ND

Declare that the DoC is issued under our sole responsibility and belongs to the following product:

Product Range: Plus Reader Series
 Type Designations: ZSR6663-EU Plus Reader
 ZSR6663-EU-T Plus Tag Tester

The object of the declaration described above is in conformity with the relevant Union harmonisation legislation:

Radio Equipment Directive 2014/53/EU

The following harmonised standards and technical specifications have been applied:

Reference & Date	Title
EN 300 220-2 V3.1.1 (2017-02)	Short Range Devices (SRD) operating in the frequency range 25 MHz to 1 000 MHz
EN 300 330 V2.1.1 (2017-02)	Short Range Devices (SRD); Radio equipment in the frequency range 9 kHz to 25 MHz and inductive loop systems in the frequency range 9 kHz to 30 MHz
Draft EN 301 489-1 V2.2.0 (2017-03)	ElectroMagnetic Compatibility (EMC) standard for radio equipment and services
Draft EN 301 489-3 V2.2.1 (2017-03)	ElectroMagnetic Compatibility (EMC) standard for radio equipment and services
Draft EN 301 489-17 V3.2.0 (2017-03)	ElectroMagnetic Compatibility (EMC) standard for radio equipment and services

Signed for and on behalf of: Avonwood Developments Ltd

Place of issue: Knoll Technology Centre
 Date of issue: 16th January 2018
 Name: Adrian Nash
 Position: Engineering Manager

Signature:



ZoneSafe is a registered trademark of Avonwood Developments Ltd.

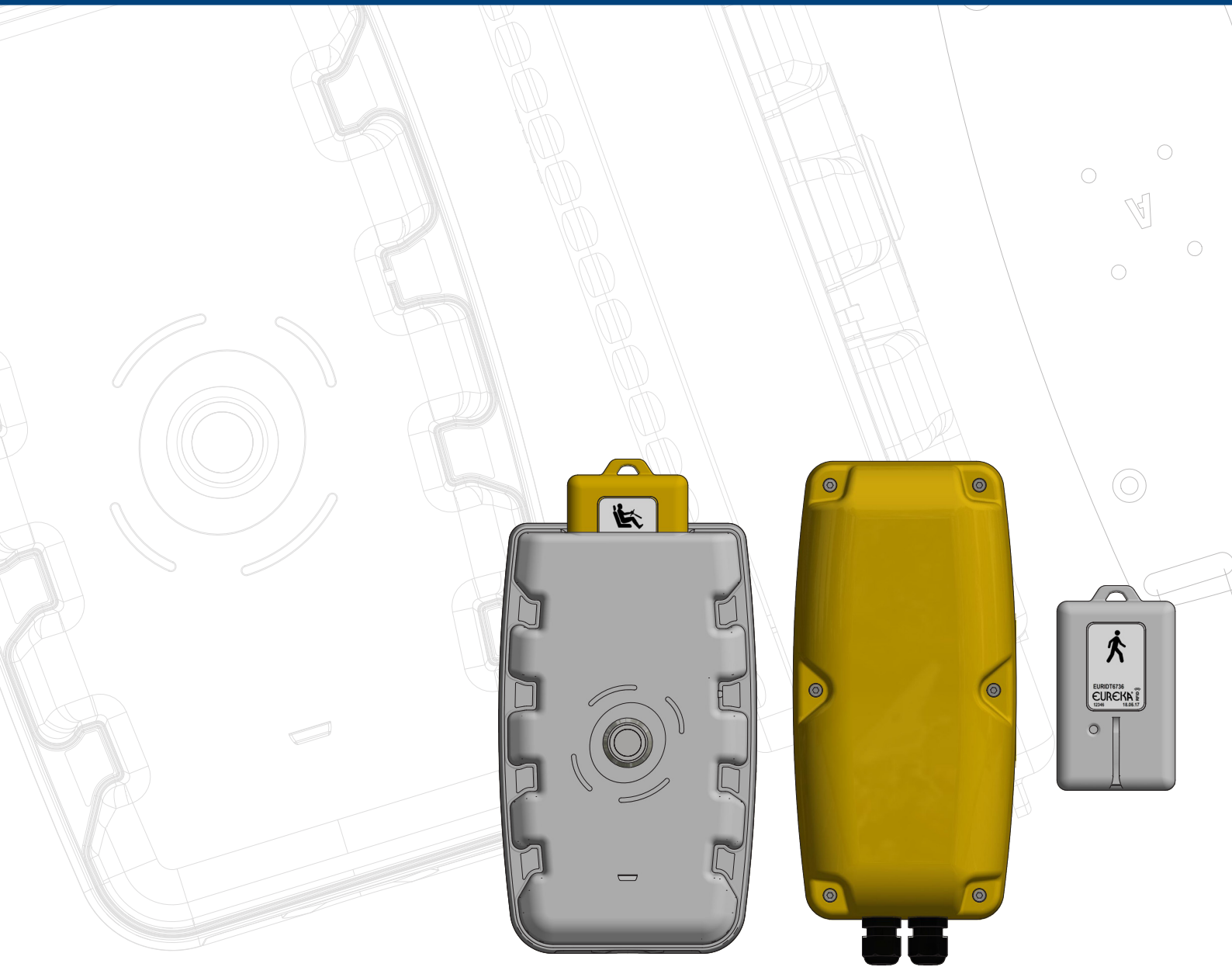

14 6784E



Avonwood Developments Ltd
Knoll Technology Centre,
Stapehill Road,
Wimborne,
Dorset, United Kingdom,
BH21 7ND

www.avonwood.co.uk
sales@avonwood.co.uk

+44 (0) 1202 868000