



## Installation Guide

---

# Standard and Enhanced Keypad

19810009 Rev F

September 2018

# Copyrights and Trademarks

## Copyright Information

Copyright © 1998-2018 by Stanley Security Solutions

All rights reserved. No part of this work covered by the copyright hereon may be reproduced or used in any form or by any means graphic, electronic, or mechanical, including photocopying, recording, taping, or information storage and retrieval systems without permission of Stanley Security Solutions.

## Trademarks

Sonitrol is a Registered Trademark of Stanley Security Solutions.

All other products are trademarks of their respective manufacturers. All registered and unregistered trademarks are the sole property of their respective companies.

## Related Publications

The table below contains related Sonitrol documents with corresponding part numbers.

Description	Part Number
iBase Installation Guide	19810005
FlexIP Installation Guide	19810065
FlexiBase Installation Guide	19810022
Panel Programming Guide	19810015
Keypad User Guide	19810016

## History of Changes:

Date	Summary of Changes
8/27/2014	Updated FCC IC information, and iCLASS mounting instructions
6/16/2017	Rev E – Updated to include FlexIP fire communicator keypad mounting instructions and compliance info.
8/31/2018	Updated FCC information and change/addition of iPROX Enhanced Keypad

# Table of Contents

<b>1. Introduction.....</b>	<b>5</b>
1.1 Copyright and Trademark.....	5
1.2 Reference Material .....	5
1.3 Overview.....	5
<b>2. Hardware .....</b>	<b>6</b>
2.1 Opening Case .....	6
2.2 Wall Mounting.....	6
2.3 Single Gang Box Mounting.....	7
2.4 Terminal Block Mounting.....	8
2.5 Keypad Wiring .....	8
2.6 Cabling Considerations .....	9
2.7 Closing Case .....	9
2.8 Specifications .....	9
<b>3. FCC .....</b>	<b>11</b>
<b>4. IC .....</b>	<b>12</b>
<b>5. STANLEY HARDWARE LIMITED WARRANTY STATEMENT .....</b>	<b>13</b>

This page is intentionally left blank.

# 1. Introduction

## 1.1 Copyright and Trademark

Copyright 2018 by Stanley Security Solutions. All rights reserved.

No part of this document may be reproduced or distributed in any form or by any means, or stored in a database or retrieval system, without the prior written permission of Sonitrol Corporation.

## 1.2 Reference Material

This manual covers the information needed to install the SonIP Standard and Enhanced Keypads. See 19810016 ~~SonIP Keypad~~ *SonIP Keypad User Guide* for user options and service procedures. See 19810005 *SonIP iBase Installation Guide* or 19810065 *FlexIP Installation Guide* for complete planning and additional installation procedures. See 19810015 *SonIP iBase/FlexiBase & FlexIP Programming Guide* for options and programming procedures.

## 1.3 Overview



The Standard and Enhanced Keypads are compatible with the SonIP- iBase, FlexiBase, and FlexIP Systems. The two keypads have the same system and programming functionality.

The Enhanced Keypad has an integrated HID iCLASS reader or a 125KHZ PROX reader that can be configured as an Arm/ Disarm reader or ingress access control.

The Standard or Enhanced Keypad is the primary user interface for navigating system programming, performing simple data entry, and controlling the SonIP iBase, FlexiBase and FlexIP System alarms and access control functions. A Liquid Crystal Display (LCD), with scrolling text, is provided for displaying data entry, system status messages, programming menus, and function options. These can be accessed and selected through the alphanumeric digital keypad. The LCD display is backlit and the keypad is low level illuminated, or in case of poor lighting conditions, may be programmed for high level illumination. The LCD backlight remains illuminated at the normal brightness at all times except when a button has been pressed. The keypad high level illumination remains active for 15 seconds after the last key press. The keypad can be mounted up to 100m (328 ft.) from the control panel, nearest module, or power hub.

**Note:** If a keypad needs to be located more than 100m (328 ft.) from the previous device, a Power Hub module must be installed in a convenient location so that the 100m (328 ft.) limitation is observed for all peripheral bus wire runs.

## 2. Hardware

Each Keypad is shipped with the following hardware

- (2) RJ-45 male crimp connectors



**CAUTION:** You must be free of static electricity before handling circuit boards. It is recommended that you wear a grounding strap or touch a bare metal surface to discharge static electricity.

### 2.1 Opening Case

Depress tabs on bottom of case using a small slotted screwdriver. The case should pop off once the second tab is depressed. The board will be located in front cover.

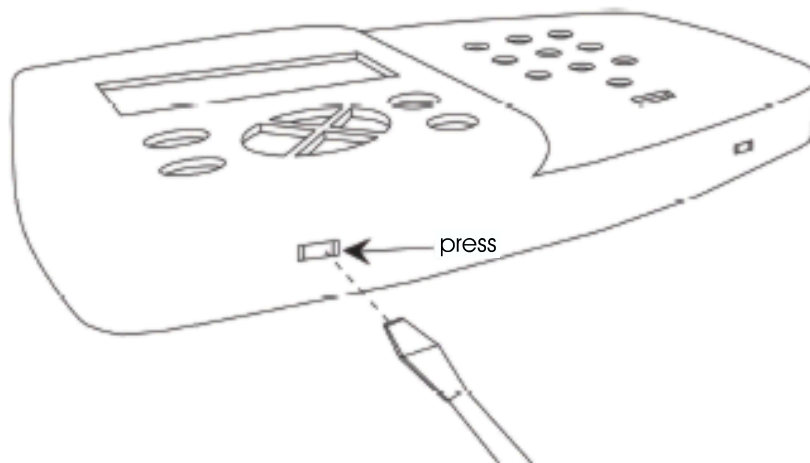

Figure 1. Depress Tab with slotted screwdriver

### 2.2 Wall Mounting

The Standard and Enhanced keypad backplate has several mounting hole locations (see Figure 2). For wall mounting use two of the middle mounting holes.



#### Note

FCC Compliance requirement - All Enhanced Keypads must be installed with metal backbox with EMT conduit runs back to control panel. (Does not apply to Standard Keypad).

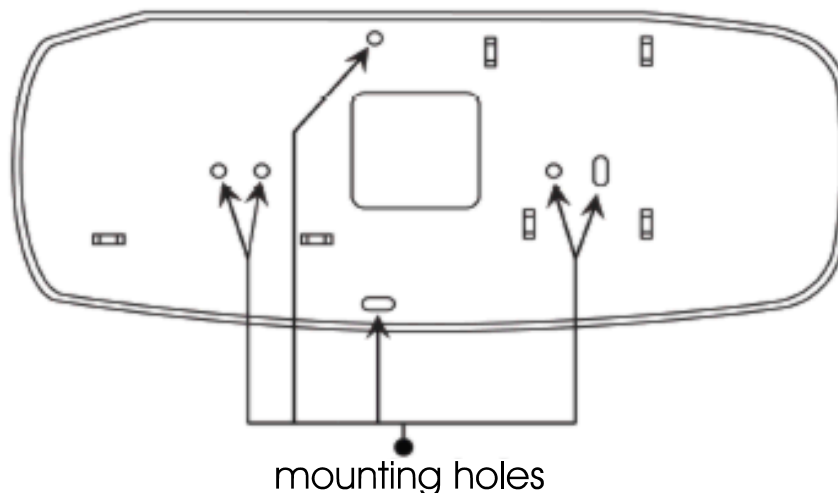

**Figure 2. Backplate Mounting Holes**

Place keypad backplate with straight edge or flat side up level on wall. Using a level, hold the backplate against the wall and mark the mounting holes. Mount the backplate using the appropriate hardware. The slotted mounting holes can be used to level during installation.

**2.3 Single Gang Box Mounting**

You can mount the Standard or Enhanced keypad directly to a single gang outlet box, either horizontally or vertically, depending on the orientation of the gang box.

**Note:** Be aware that the backplate may not completely cover the box.

Recommended wire gauges for typical keypad installations are 16-18 AWG.

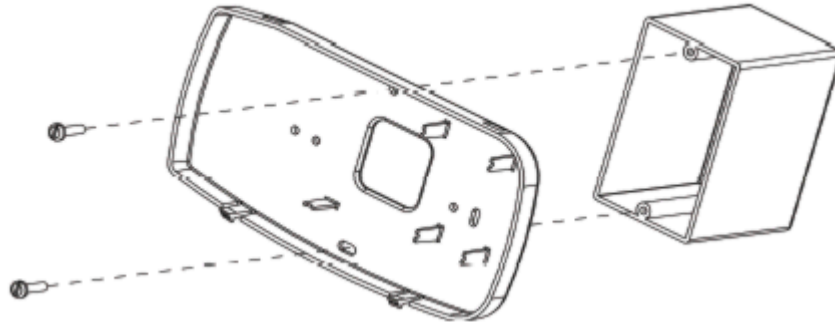

**Figure 3. Gang Box Mounting**

Dip Switch Settings: Determine the appropriate address for this module and set the address switches as follows:

**Note:** On Dip switch 1 (labeled DPSW1 on PCA) slide the switch to the ON position for a 1 and to the OFF position for a 0.

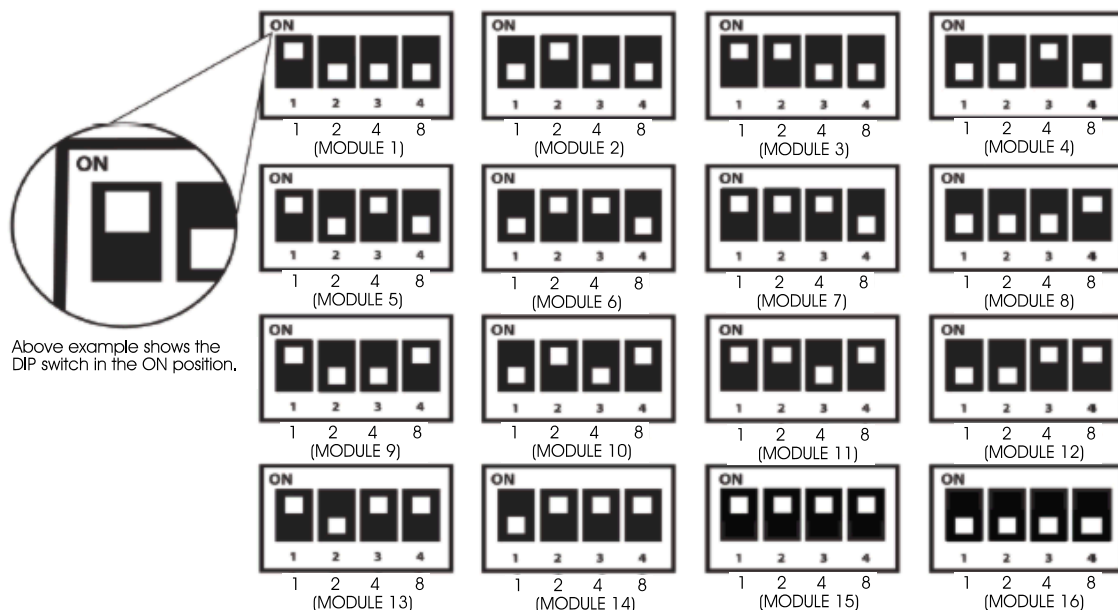
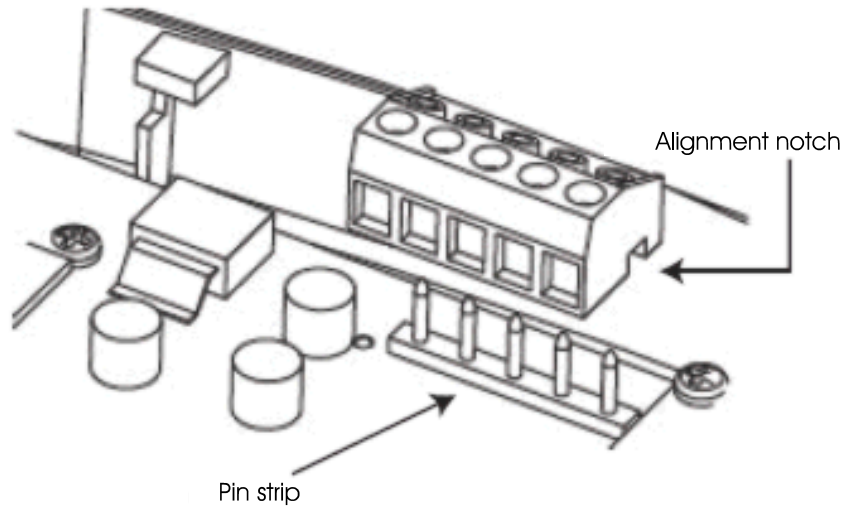

**Figure 4. Dip Switch Addresses**

**Note:** The addresses of the Keypads correspond to the number of keypads in the system. The dip switch addresses also represent the last octet of the modules IP address (192.168.60.1 – 192.168.60.16). To address the keypad use consecutive numbers from 1-16. Do not duplicate address switch settings.

## 2.4 Terminal Block Mounting

1. The terminal blocks are removable for wiring. They are not directional and can be installed incorrectly. Re-install by aligning the correct number of positions terminal block over the pins and the slot over the pin strip and pressing down.



**Figure 5. Mounting Terminal Block on Board**

2. If the terminal blocks become separated they can easily be reassembled by sliding the grooved edge into the receiving slot on the other piece.

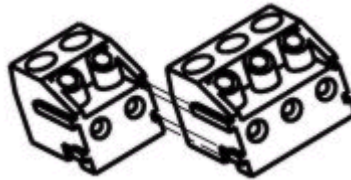

**Figure 6. Terminal Block Assembly**

## 2.5 Keypad Wiring

Remove keypad terminal block and connect appropriate wires. To ensure proper connections, each connection is silk-screened on the keypad circuit board. The keypad connections at the control panel must match connections at Keypad.

- **J3:**

- +12V, Positive power supply input connection for Keypad
- GND, Negative power supply input connection for Keypad
- BEEP OUT, Open Collector Output for sounding an external sounder or driving an external LED

**Note:** UL requires that there be NO CONNECTION to this output, which goes low while the keypad is beeping.

- +12V, Positive power supply output connection for Keypad
- GND, Negative power supply output connection for Keypad

- **J1:**

- LAN IN - Peripheral Bus Data Connections

- **J2:**

- LAN OUT - Peripheral Bus Data Connections



## 2.6 Cabling Considerations

If a keypad needs to be located more than 100m (328 ft.) from the previous device, a Power Hub module must be installed in a convenient location so that the 100m (328 ft.) limitation is observed for all peripheral bus wire runs.

- Sonitrol recommends that you use CAT 5, 5e, 6 or 6e cable when running Standard and Enhanced keypad cables.
- DO NOT run cables parallel to AC wiring, unless the AC is in metallic conduit.
- Avoid mounting the keypad next to a light switch or electrical outlet.
- Keep wires away from fluorescent light fixtures. Fluorescent lights produce a high level of electrical noise.
- Keep cables away from high current devices (i.e., motors, welders, etc.) which might induce spikes into the wires.

Attach the Standard or Enhanced keypad to the backplate after completing all wiring and checks

## 2.7 Closing Case

Insert upper tabs into slots and press bottom of keypad in until lower tabs snap into place. You should hear a click when case is properly closed.

## 2.8 FlexIP Fire Communicator

When installing the Keypad at a FlexIP system where the FlexIP will operate as a fire communicator (see Doc# 19810178 for details), the following keypad mounting procedure must be followed.

1. Address the keypad mounted at the FlexIP enclosure as Keypad 1.
2. For installations in U.S., the keypad can be mounted directly to the enclosure or to a separate close nipple box connected to the enclosure via conduit. For installations in Canada, the keypad shall be mounted in a separate close nipple box connected to the enclosure via conduit.
3. When mounting the keypad on the outside of the enclosure door, the keypad shall be mounted a minimum of 2 inches below the Sonitrol logo and a minimum of 1 inch from the bottom and sides of the enclosure.
4. When mounting the keypad on the outside of the enclosure door, the size of the enclosure hole intended for the keypad shall be a maximum of 1.25 inches in diameter.

## 2.9 Specifications

- Supply voltage: 12-14 VDC
- Dimensions:
  - Enhanced: 9.5" W x 4.5" H (24.1cm x 11.4 cm)
  - Standard: 8" W x 4.5" H (20.3 cm x 11.4 cm)
- Operating Temperature: 32 to 122°F (0 to 50°C)
- Humidity: 93% non-condensing
- Patent: Pending
- Current consumption on:
  - Standard Keypad: 275mA max
  - Enhanced Keypad: 375mA max
- UL Listings:
  - UL 294 - Access Control System Units
  - UL 365 - Police Station Connected Burglar Alarm Units and Systems

- UL 609 - Local Burglar Alarm Units and Systems
- UL 864 - Control Units and Accessories for Fire Alarm Systems
- UL 1076 - Proprietary Burglar Alarm Units and Systems
- UL 1610 - Central-Station Burglar-Alarm Units
- UL 1635 - Digital Alarm Communicator System Units
- ULC Listings:
  - CAN/ULC-S303-M91 - Local Burglar Alarm Units and Systems
  - CAN/ULC - S304-06 - Signal Receiving Center and Premise Burglar Alarm Control Units
    - Active Level = A1 minimum risk for ULC
  - CSA C22.2 No 205 - Signal Equipment
  - ULC/ORD-C1076-86 - Proprietary Burglar Alarm Units and Systems
  - ULC S559 - Equipment for Fire Signal Receiving Centres and Systems

**Note**

The Enhanced Keypad is not a UL tested or listed product.

### 3. FCC (Standard and iProx Enhanced)

**Warning:** Changes or modifications to this device not expressly approved by Stanley Security Solutions could void the user's authority to operate the equipment.

**Note:** This equipment has been tested and found to comply with the limits for a Class B digital device, pursuant to Part 15 of the FCC Rules. These limits are designed to provide reasonable protection against harmful interference in a residential installation. This equipment generates, uses, and can radiate radio frequency energy and, if not installed and used in accordance with the instructions, may cause harmful interference to radio communications. However, there is no guarantee that interference will not occur in a particular installation. If this equipment does cause harmful interference to radio or television reception, which can be determined by turning the equipment off and on, the user is encouraged to try to correct the interference by one or more of the following measures:

- Reorient or relocate the receiving antenna.
- Increase the separation between the equipment and receiver.
- Connect the equipment into an outlet on a circuit different from that to which the receiver is connected.
- Consult the dealer or an experienced radio/TV technician for help.

**FCC ID:** 2ACWM-SONIPPROXKP

THIS DEVICE COMPLIES WITH PART 15 OF THE FCC RULES. OPERATION IS SUBJECT TO THE FOLLOWING TWO CONDITIONS: (1) THIS DEVICE MAY NOT CAUSE HARMFUL INTERFERENCE, AND (2) THIS DEVICE MUST ACCEPT ANY INTERFERENCE RECEIVED, INCLUDING INTERFERENCE THAT MAY CAUSE UNDESIRE OPERATION. IN COMPLIANCE WITH FCC REQUIREMENT 15.27 NO SPECIAL ACCESSORIES ARE REQUIRED IN ORDER TO COMPLY WITH PART 15 OF THE FCC REGULATIONS. CHANGES OR MODIFICATIONS NOT EXPRESSLY APPROVED BY SONITROL COULD VOID THE USER'S AUTHORITY TO OPERATE THE EQUIPMENT.

This equipment complies with FCC radiation exposure limits set forth for an uncontrolled environment. This equipment is in direct contact with the body of the user under normal operating conditions. This transmitter must not be co-located or operating in conjunction with any other antenna or transmitter.

## 4. IC

**Note:** Under Industry Canada regulations, this radio transmitter may only operate using an antenna of a type and maximum (or lesser) gain approved for the transmitter by Industry Canada. To reduce potential radio interference to other users, the antenna type and its gain should be so chosen that the equivalent isotropically radiated power (e.i.r.p.) is not more than that necessary for successful communication.

Conformément à la réglementation d'Industrie Canada, le présent émetteur radio peut fonctionner avec une antenne d'un type et d'un gain maximal (ou inférieur) approuvé pour l'émetteur par Industrie Canada. Dans le but de réduire les risques de brouillage radioélectrique à l'intention des autres utilisateurs, il faut choisir le type d'antenne et son gain de sorte que la puissance isotrope rayonnée équivalente (p.i.r.e.) ne dépasse pas l'intensité nécessaire à l'établissement d'une communication satisfaisante.

This device complies with Industry Canada's licence-exempt RSSs. Operation is subject to the following two conditions:

- (1) This device may not cause interference; and
- (2) This device must accept any interference, including interference that may cause undesired operation of the device.

Le présent appareil est conforme aux CNR d'Industrie Canada applicables aux appareils radio exempts de licence. L'exploitation est autorisée aux deux conditions suivantes :

- (1) l'appareil ne doit pas produire de brouillage;
- (2) l'appareil doit accepter tout brouillage radioélectrique subi, même si le brouillage est susceptible d'en compromettre le fonctionnement.

**IC ID:** 7309A-SONIPPROXKP

This Class B digital apparatus complies with Canadian CAN ICES-3 (B)/NMB-3(B)

Cet appareil numérique de la classe B est conforme à la norme CAN ICES-3 (B)/NMB-3(B) du Canada.

**Canadian Point of Contact**

David P. Jones, President / Paul A. Nickel, Vice President

Sonitrol Distribution Canada, Inc.

5875 Kennedy Road

Mississauga, Ontario L4Z 2G3

Canada

Tel: [+1 905-890 7727](tel:+19058907727)

## **5. STANLEY HARDWARE LIMITED WARRANTY STATEMENT**

Stanley warrants each new product of its manufacture, to be free from defects in material and workmanship. It will repair or replace defective parts for a period of 24 months from the date of manufacture, providing the equipment has not been subjected to abnormal conditions such as misuse, abuse, misapplication, alteration, lightning damage or damage by an Act of God. This excludes packing, handling and shipping charges from the Customer. The limited warranty is restricted to the original purchaser.

ALL OTHER WARRANTIES, EXPRESSED OR IMPLIED, INCLUDING MERCHANT ABILITY, THE FITNESS OF EQUIPMENT FOR A PARTICULAR PURPOSE OR WITH RESPECT TO CLAIMS OF ANY THIRD PARTY BY THE WAY OF INFRINGEMENT OR THE LIKE, ARE EXCLUDED.