

FCC Radio Test Report

FCC ID: 2ACVUTE-WM03

Report No. : TB-FCC141299
Applicant : Active Key GmbH & Co. KG

Equipment Under Test (EUT)

EUT Name : Silicone Waterproof Laser Mouse
Model No. : TE-WM03
Serial No. : N/A
Brand Name : Active Key
Receipt Date : 2014-7-18
Test Date : 2014-07-18 to 2014-07-31
Issue Date : 2014-08-04
Standards : FCC Part 15, Subpart C
Test Method : ANSI C63.4:2003
Conclusions : **PASS**

In the configuration tested, the EUT complied with the standards specified above,
The EUT technically complies with the FCC requirements

Test/Witness Engineer :

Ivan Su

Approved & Authorized :

Ray Ho



This report details the results of the testing carried out on one sample. The results contained in this test report do not relate to other samples of the same product. The manufacturer should ensure that all products in series production are in conformity with the product sample detailed in the report.

Contents

CONTENTS.....	2
1. GENERAL INFORMATION ABOUT EUT	4
1.1 Client Information.....	4
1.2 General Description of EUT (Equipment Under Test)	4
1.3 Block Diagram Showing the Configuration of System Tested.....	5
1.4 Description of Support Units	5
1.5 Description of Test Mode.....	6
1.6 Description of Test Software Setting	6
1.7 Test Facility.....	7
2. TEST SUMMARY	8
3. CONDUCTED EMISSION TEST	9
3.1 Test Standard and Limit.....	9
3.2 Test Setup.....	9
3.3 Test Procedure.....	9
3.4 Test Equipment Used.....	10
3.5 EUT Operating Mode	10
3.6 Test Data.....	10
4. RADIATED EMISSION TEST	11
4.1 Test Standard and Limit.....	11
4.2 Test Setup.....	12
4.3 Test Procedure.....	13
4.4 EUT Operating Condition	13
4.5 Test Equipment	14
4.6 Test Data.....	14
5. RESTRICTED BANDS REQUIREMENT	23
5.1 Test Standard and Limit.....	23
5.2 Test Setup.....	23
5.3 Test Procedure.....	24
5.4 EUT Operating Condition	24
5.5 Test Equipment	24
5.6 Test Data.....	24
6. BANDWIDTH TEST	31
6.1 Test Setup.....	31
6.2 Test Procedure.....	31
6.3 EUT Operating Condition	31
6.4 Test Equipment	31
6.5 Test Data.....	31
7. ANTENNA REQUIREMENT.....	35
7.1 Standard Requirement.....	35

7.2 Antenna Connected Construction	35
7.3 Result.....	35

1. General Information about EUT

1.1 Client Information

Applicant	:	Active Key GmbH & Co. KG
Address	:	Badstrasse 13 - 15,91257 Pegnitz Germany
Manufacturer	:	Techvane Industrial Co.,Limited
Address	:	1st & 2nd Floor, Block 25, Chentian Industrial Zone, Xixiang, Baoan, Shenzhen, China

1.2 General Description of EUT (Equipment Under Test)

EUT Name	:	Silicone Waterproof Laser Mouse	
Models No.	:	TE-WM03	
Model Difference	:	N/A	
Product Description	:	Operation Frequency:2402~2480 MHz	
		Number of Channels:	79 channels
		Out Power:	86.70 dBuV/m@3m Peak 86.47 dBuV/m@3m Avg
		Antenna Gain:	0 dBi
		Modulation Type:	FSK
Power Supply	:	DC Voltage supplied by AA battery.	
Power Rating	:	DC 3.0V (2*AA battery).	
Connecting I/O Port(S)	:	Please refer to the User's Manual	

Note:

(1) For a more detailed features description, please refer to the manufacturer's specifications or the User's Manual.

(2) Channel List:

Channel	Frequency (MHz)	Channel	Frequency (MHz)	Channel	Frequency (MHz)
00	2402	27	2429	54	2456
01	2403	28	2430	55	2457
02	2404	29	2431	56	2458
03	2405	30	2432	57	2459
04	2406	31	2433	58	2460
05	2407	32	2434	59	2461
06	2408	33	2435	60	2462

07	2409	34	2436	61	2463
08	2410	35	2437	62	2464
09	2411	36	2438	63	2465
10	2412	37	2439	64	2466
11	2413	38	2440	65	2467
12	2414	39	2441	66	2468
13	2415	40	2442	67	2469
14	2416	41	2443	68	2470
15	2417	42	2444	69	2471
16	2418	43	2445	70	2472
17	2419	44	2446	71	2473
18	2420	45	2447	72	2474
19	2421	46	2448	73	2475
20	2422	47	2449	74	2476
21	2423	48	2450	75	2477
22	2424	49	2451	76	2478
23	2425	50	2452	77	2479
24	2426	51	2453	78	2480
25	2427	52	2454		
26	2428	53	2455		

1.3 Block Diagram Showing the Configuration of System Tested

Mode 1: TX Mode

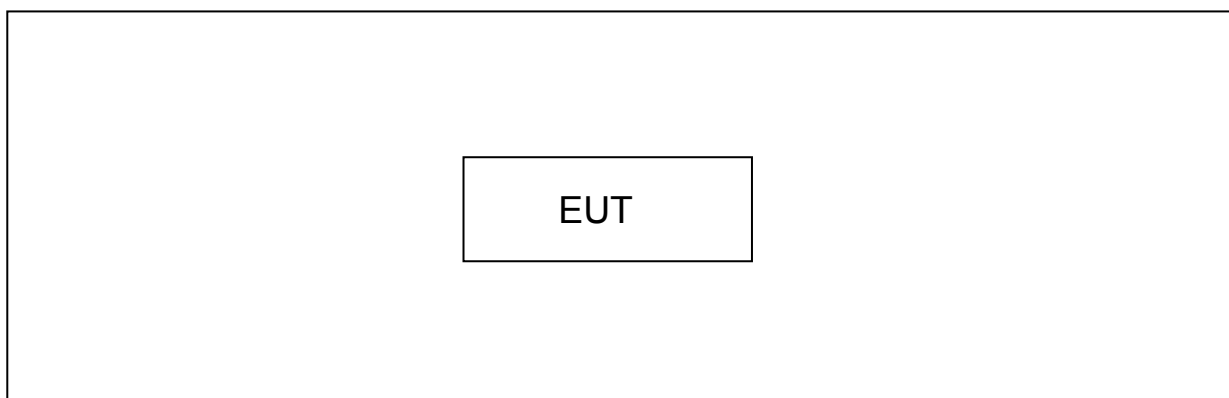

1.4 Description of Support Units

The EUT has been tested as an independent unit.

Name	Model	S/N	Manufacturer	Used “√”
------	-------	-----	--------------	----------

---	---	---	---	---
-----	-----	-----	-----	-----

1.5 Description of Test Mode

To investigate the maximum EMI emission characteristics generates from EUT, the test system was pre-scanning tested base on the consideration of following EUT operation mode or test configuration mode which possible have effect on EMI emission level. Each of these EUT operation mode(s) or test configuration mode(s) mentioned follow was evaluated respectively.

For Conducted Test	
Final Test Mode	Description
N/A	N/A

For Radiated Test	
Final Test Mode	Description
Mode 1	TX Mode

Note:

For all test, we have verified the construction and function in typical operation. And all the test modes were carried out with the EUT in transmitting operation in maximum power with all kinds of data rate.

- (1)According to ANSI C63.4 standards, the measurements are performed at the highest, middle, lowest available channels.
- (2)During the testing procedure, the continuously transmitting with the maximum power mode was programmed by the customer.
- (3) The EUT is considered a portable unit; it was pre-tested on the positioned of each 3 axis, X-plane, Y-plane and Z-plane. The worst case was found positioned on X-plane. Therefore only the test data of this X-plane was used for radiated emission measurement test.
- (4) During testing the EUT is powered by new battery.

1.6 Description of Test Software Setting

During testing channel & Power controlling software provided by the customer was used to control the operating channel as well as the output power level. The RF output power selection is for the setting of RF output power expected by the customer and is going to be fixed on the firmware of the final end product power parameters of RF mode.

1.7 Test Facility

The testing was performed by the Shenzhen Toby Technology Co., Ltd., in their facilities located at:

1A/F., Bldg.6, Yusheng Industrial Zone, The National Road No.107 Xixiang Section 467, Xixiang, Bao'an, Shenzhen, Guangdong, China.

At the time of testing, the following bodies accredited the Laboratory:

CNAS (L5813)

The Laboratory has been accredited by CNAS to ISO/IEC 17025: 2005 General Requirements for the Competence of Testing and Calibration Laboratories for the competence in the field of testing. And the Registration No.: CNAS L5813.

FCC List No.: (811562)

The Laboratory is listed in the United States of American Federal Communications Commission (FCC), and the registration number is 811562.

IC Registration No.: (11950A-1)

The Laboratory has been registered by Certification and Engineering Bureau of Industry Canada for radio equipment testing. The site registration: Site# 11950A-1.

2. Test Summary

FCC Part 15 Subpart C(15.249)			
Standard Section	Test Item	Judgment	Remark
15.203	Antenna Requirement	PASS	N/A
15.205	Restricted Bands	PASS	N/A
15.207	AC Power Conducted Emission	N/A	N/A
15.249 &15.209	Radiated Spurious Emission	PASS	N/A
15.215(C)	20dB Bandwidth	PASS	N/A

Note: N/A is an abbreviation for Not Applicable.

3. Conducted Emission Test

3.1 Test Standard and Limit

3.1.1 Test Standard

FCC Part 15.207

3.1.2 Test Limit

Conducted Emission Test Limit

Frequency	Maximum RF Line Voltage (dB μ V)	
	Quasi-peak Level	Average Level
150kHz~500kHz	66 ~ 56 *	56 ~ 46 *
500kHz~5MHz	56	46
5MHz~30MHz	60	50

Notes:

(1) *Decreasing linearly with logarithm of the frequency.

(2) The lower limit shall apply at the transition frequencies.

(3) The limit decrease in line with the logarithm of the frequency in the range of 0.15 to 0.50MHz.

3.2 Test Setup

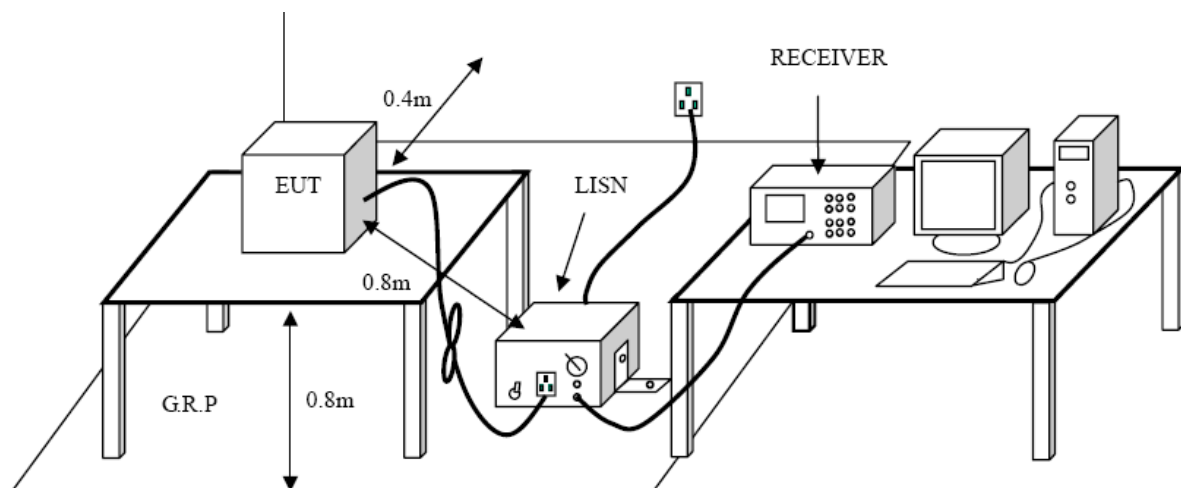

3.3 Test Procedure

The EUT was placed 0.8 meters from the horizontal ground plane with EUT being connected to the power mains through a line impedance stabilization network (LISN). All other support equipments powered from additional LISN(s). The LISN provide 50 Ohm/ 50uH of coupling impedance for the measuring instrument.

Interconnecting cables that hang closer than 40 cm to the ground plane shall be folded back and forth in the center forming a bundle 30 to 40 cm long.

I/O cables that are not connected to a peripheral shall be bundled in the center. The end of the cable may be terminated, if required, using the correct terminating impedance. The overall length shall not exceed 1 m.

LISN is at least 80 cm from nearest part of EUT chassis.

The bandwidth of EMI test receiver is set at 9kHz, and the test frequency band is from 0.15MHz to 30MHz.

3.4 Test Equipment Used

Description	Manufacturer	Model No.	Serial No.	Cal. Date	Cal. Due Date
EMI Test Receiver	ROHDE & SCHWARZ	ESCI	100321	2013-08-10	2014-08-09
50Ω Coaxial Switch	Anritsu	MP59B	X10321	2013-08-10	2014-08-09
L.I.S.N	Rohde & Schwarz	ENV216	101131	2013-08-10	2014-08-09
L.I.S.N	SCHWARZBECK	NNBL 8226-2	8226-2/164	2013-08-10	2014-08-09

3.5 EUT Operating Mode

Please refer to the description of test mode.

3.6 Test Data

The EUT is powered by battery, so no requirement for this test item.

4. Radiated Emission Test

4.1 Test Standard and Limit

4.1.1 Test Standard

FCC Part 15.209

4.1.2 Test Limit

Radiated Emission Limit (9kHz~1000MHz)

Frequency (MHz)	Field Strength (microvolt/meter)	Measurement Distance (meters)
0.009~0.490	2400/F(KHz)	300
0.490~1.705	24000/F(KHz)	30
1.705~30.0	30	30
30~88	100	3
88~216	150	3
216~960	200	3
Above 960	500	3

Radiated Emission Limit (Above 1000MHz)

Frequency (MHz)	Class A (dBuV/m)(at 3 M)		Class B (dBuV/m)(at 3 M)	
	Peak	Average	Peak	Average
Above 1000	80	60	74	54

Note:

- (1) The tighter limit applies at the band edges.
- (2) Emission Level(dBuV/m)=20log Emission Level(Uv/m)

Limits of radiated emission measurement (15.249)

FCC Part 15 (15.249), Subpart C	
Limit	Frequency Range (MHz)
Field strength of fundamental 50000 μ V/m (94 dB μ V/m) @ 3 m	2400~2483.5

4.2 Test Setup

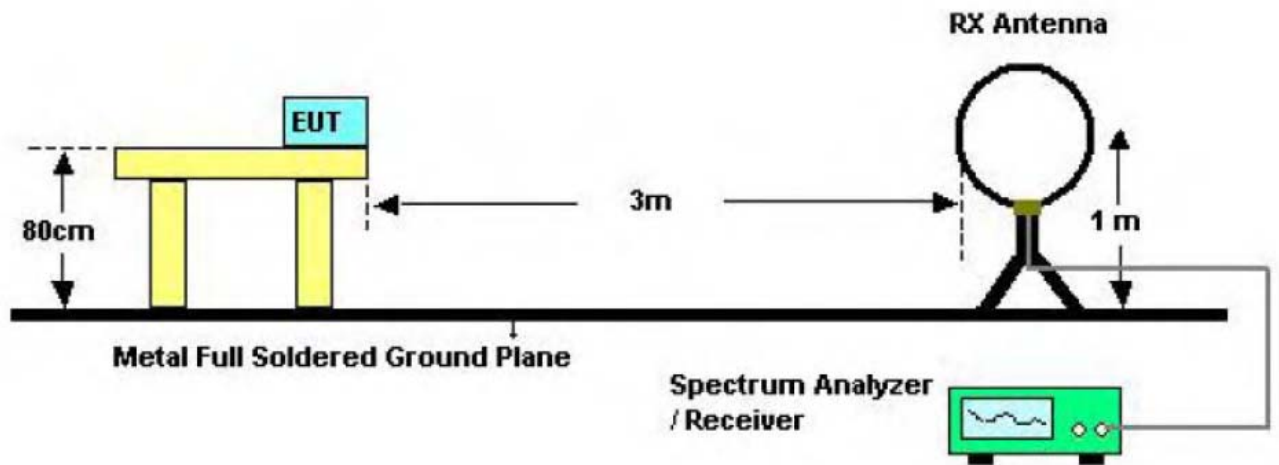

Bellow 30MHz Test Setup

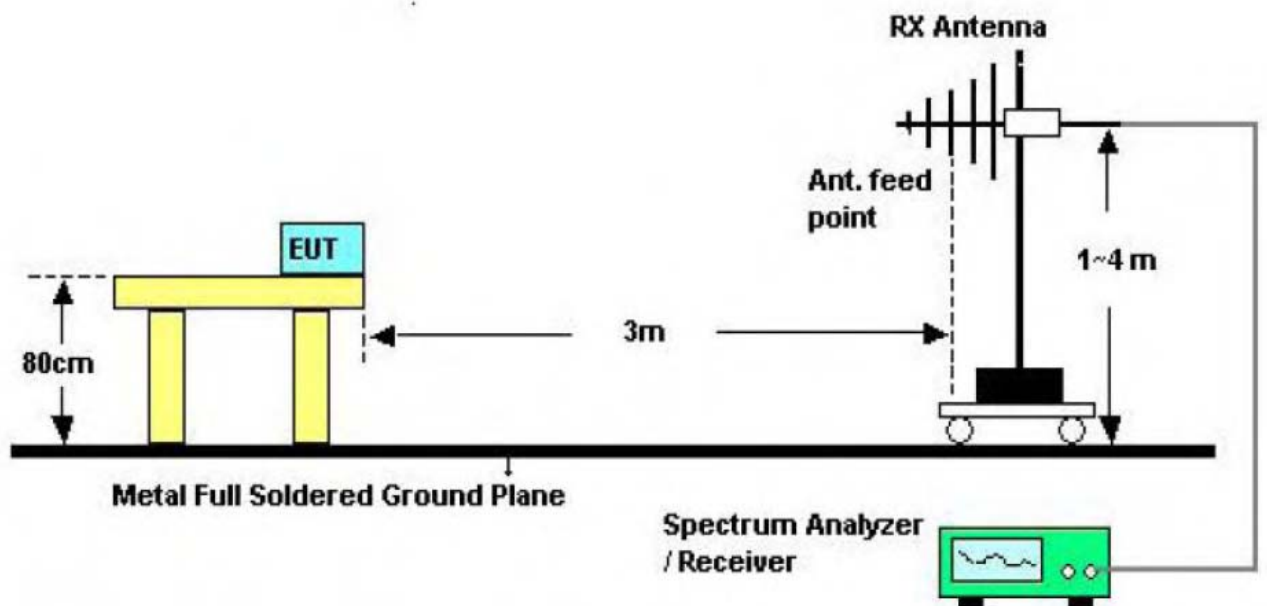

Bellow 1000MHz Test Setup

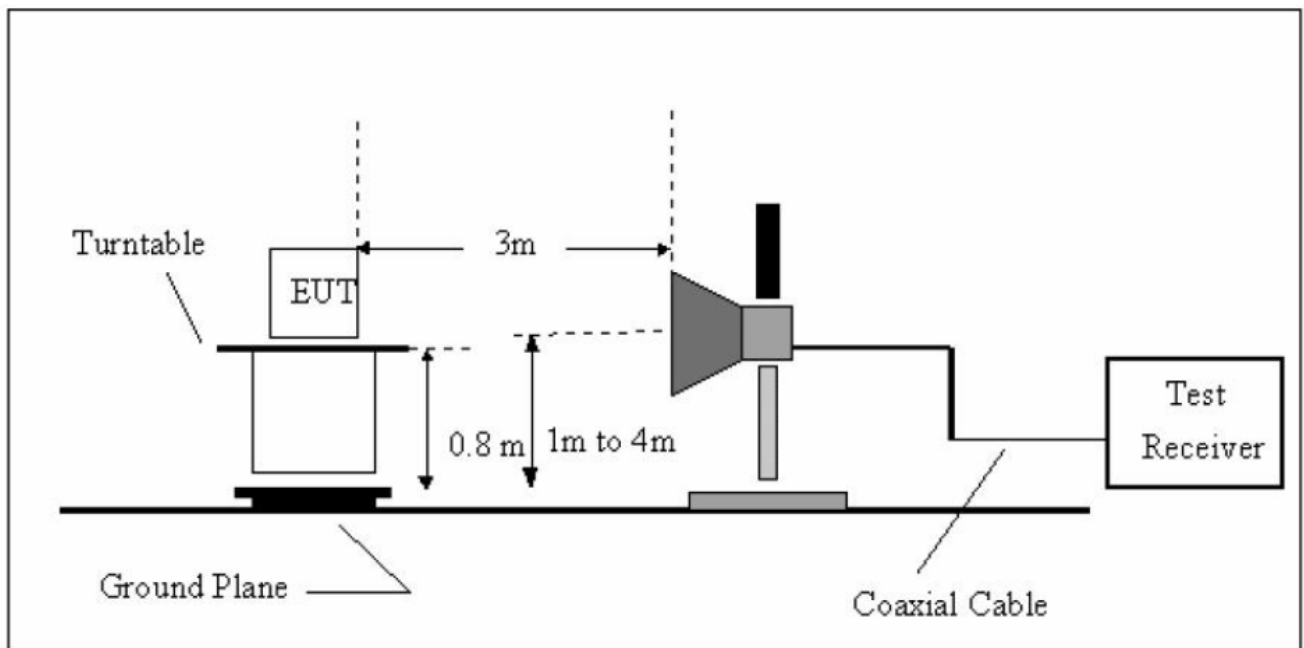

Above 1GHz Test Setup

4.3 Test Procedure

- (1) The measuring distance of 3m shall be used for measurements at frequency up to 1GHz and above 1 GHz. The EUT was placed on a rotating 0.8m high above ground, the table was rotated 360 degrees to determine the position of the highest radiation.
- (2) The Test antenna shall vary between 1m and 4m, Both Horizontal and Vertical antenna are set to make measurement.
- (3) The initial step in collecting conducted emission data is a spectrum analyzer peak detector mode pre-scanning the measurement frequency range. Significant peaks are then marked and then Quasi Peak detector mode re-measured.
- (4) If the Peak Mode measured value compliance with and lower than Quasi Peak Mode Limit Bellow 1 GHz, the EUT shall be deemed to meet QP Limits and then no additional QP Mode measurement performed. But the Peak Value and average value both need to comply with applicable limit above 1 GHz.
- (5) For the actual test configuration, please see the test setup photo.

4.4 EUT Operating Condition

The EUT was set to Continual Transmitting in maximum power, and new batteries are used during testing.

4.5 Test Equipment

Equipment	Manufacturer	Model No.	Serial No.	Last Cal.	Cal. Due Date
Spectrum Analyzer	Agilent	E4407B	MY45106456	Mar. 20, 2014	Mar. 19, 2015
Spectrum Analyzer	Rohde & Schwarz	FSP30	DE25181	Aug. 10, 2013	Aug.09, 2014
EMI Test Receiver	Rohde & Schwarz	ESCI	101165	Aug. 10, 2013	Aug.09, 2014
Bilog Antenna	ETS-LINDGREN	3142E	00117537	Mar. 07, 2014	Mar.06, 2015
Horn Antenna	ETS-LINDGREN	3117	00143207	Mar. 07, 2014	Mar.06, 2015
Pre-amplifier	HP	11909A	185903	Mar. 07, 2014	Mar.06, 2015
Pre-amplifier	HP	8447B	3008A00849	Mar. 07, 2014	Mar.06, 2015
Cable	HUBER+SUHNER	100	SUCOFLEX	Mar. 07, 2014	Mar.06, 2015
Signal Generator	Rohde & Schwarz	SML03	IKW682-054	Feb. 11, 2014	Feb.10, 2015
Positioning Controller	ETS-LINDGREN	2090	N/A	N/A	N/A

4.6 Test Data

Please see the next page.

EUT:	Silicone Waterproof Laser Mouse	Model Name :	TE-WM03
Temperature:	25 °C	Relative Humidity:	55%
Test Voltage:	DC 3.0V		
Ant. Pol.	Horizontal		
Test Mode:	TX Mode 2402MHz		
Remark:	Only worse case is reported		

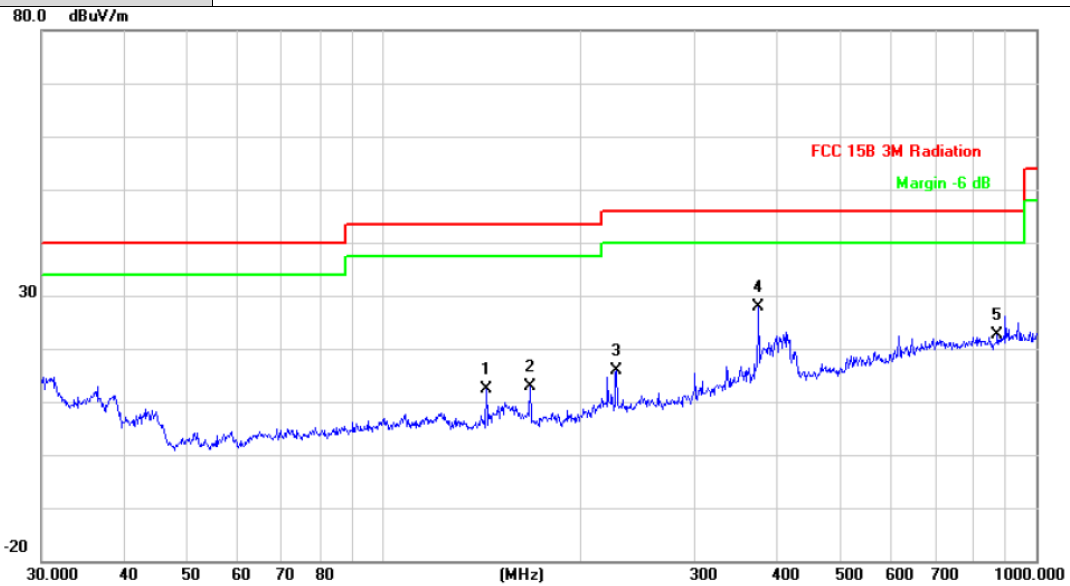

No.	Mk.	Freq.	Reading Level	Correct Factor	Measurement	Limit	Over	Detector
		MHz	dBuV	dB/m	dBuV/m	dBuV/m	dB	
1		143.8295	33.99	-21.67	12.32	43.50	-31.18	peak
2		167.8243	34.03	-21.04	12.99	43.50	-30.51	peak
3		227.6906	35.01	-19.18	15.83	46.00	-30.17	peak
4	*	375.9385	42.33	-14.40	27.93	46.00	-18.07	peak
5		872.1832	28.63	-6.10	22.53	46.00	-23.47	peak

Emission Level= Read Level+ Correct Factor

EUT:	Silicone Waterproof Laser Mouse	Model Name :	TE-WM03
Temperature:	25 °C	Relative Humidity:	55%
Test Voltage:	DC 3.0V		
Ant. Pol.	Vertical		
Test Mode:	TX Mode 2402MHz		
Remark:	Only worse case is reported		

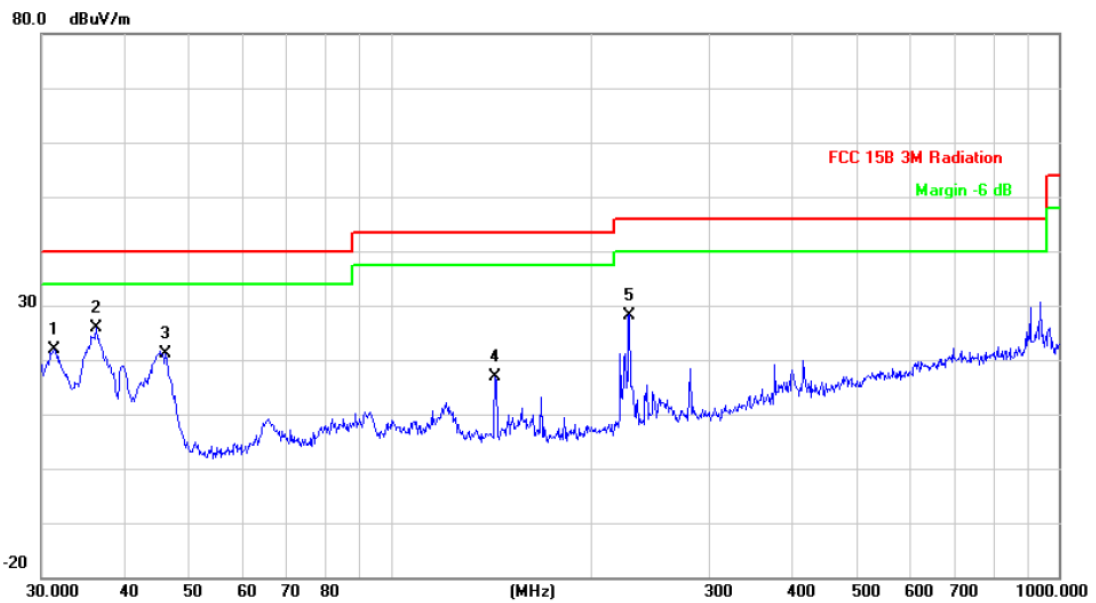

No.	Mk.	Freq.	Reading Level	Correct Factor	Measurement	Limit	Over	
		MHz	dBuV	dB/m	dBuV/m	dBuV/m	dB	Detector
1		31.3992	36.68	-14.83	21.85	40.00	-18.15	peak
2	*	36.2541	43.77	-17.83	25.94	40.00	-14.06	peak
3		46.0164	43.76	-22.71	21.05	40.00	-18.95	peak
4		143.3261	38.66	-21.71	16.95	43.50	-26.55	peak
5		227.6906	47.43	-19.18	28.25	46.00	-17.75	peak

Emission Level= Read Level+ Correct Factor

EUT:	Silicone Waterproof Laser Mouse	Model Name :	TE-WM03
Temperature:	25 °C	Relative Humidity:	55%
Test Voltage:	DC 3.0V		
Ant. Pol.	Horizontal		
Test Mode:	TX FSK Mode 2402MHz		
Remark:	No report for the emission which more than 10 dB below the prescribed limit.		

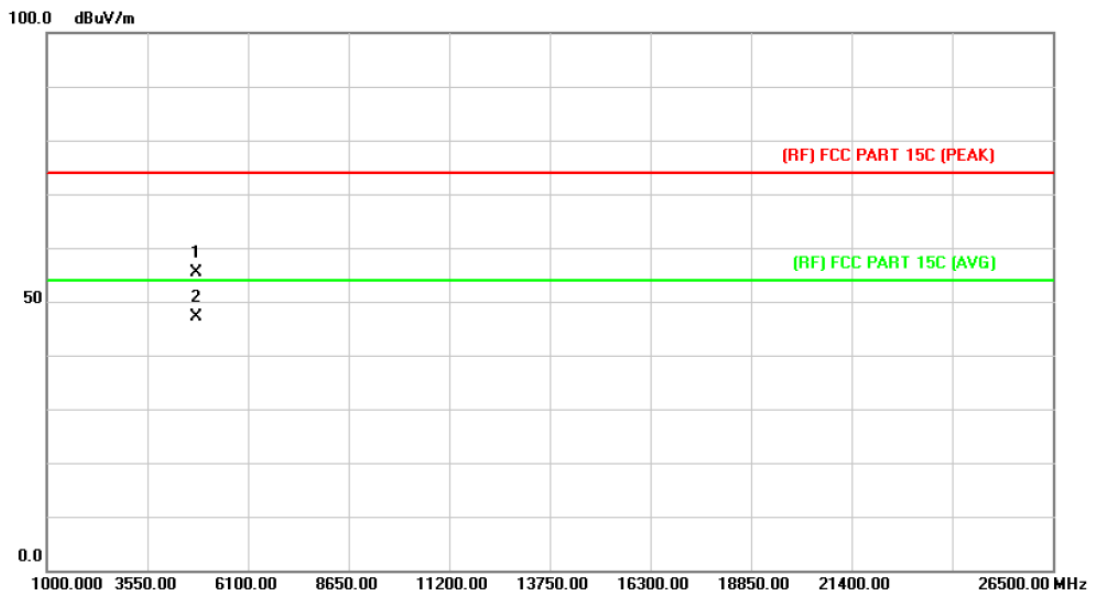

No.	Mk.	Freq. MHz	Reading Level dBuV	Correct Factor dB/m	Measure- ment dBuV/m	Limit dBuV/m	Over dB	Detector
1		4803.990	41.88	13.44	55.32	74.00	-18.68	peak
2	*	4803.990	33.65	13.44	47.09	54.00	-6.91	AVG

Emission Level= Read Level+ Correct Factor

EUT:	Silicone Waterproof Laser Mouse	Model Name :	TE-WM03
Temperature:	25 °C	Relative Humidity:	55%
Test Voltage:	DC 3.0V		
Ant. Pol.	Vertical		
Test Mode:	TX FSK Mode 2402MHz		
Remark:	No report for the emission which more than 10 dB below the prescribed limit.		

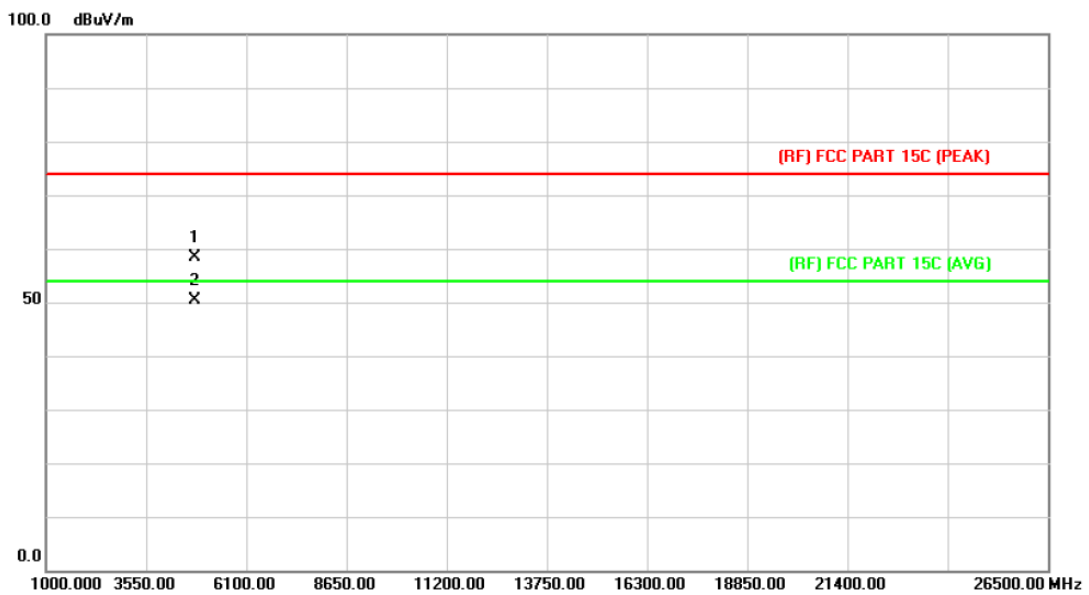

No.	Mk.	Freq. MHz	Reading Level dBuV	Correct Factor dB/m	Measure- ment dBuV/m	Limit dBuV/m	Over dB	Detector
1		4803.990	45.00	13.44	58.44	74.00	-15.56	peak
2	*	4803.990	36.97	13.44	50.41	54.00	-3.59	AVG

Emission Level= Read Level+ Correct Factor

EUT:	Silicone Waterproof Laser Mouse	Model Name :	TE-WM03
Temperature:	25 °C	Relative Humidity:	55%
Test Voltage:	DC 3.0V		
Ant. Pol.	Horizontal		
Test Mode:	TX FSK Mode 2440MHz		
Remark:	No report for the emission which more than 10 dB below the prescribed limit.		

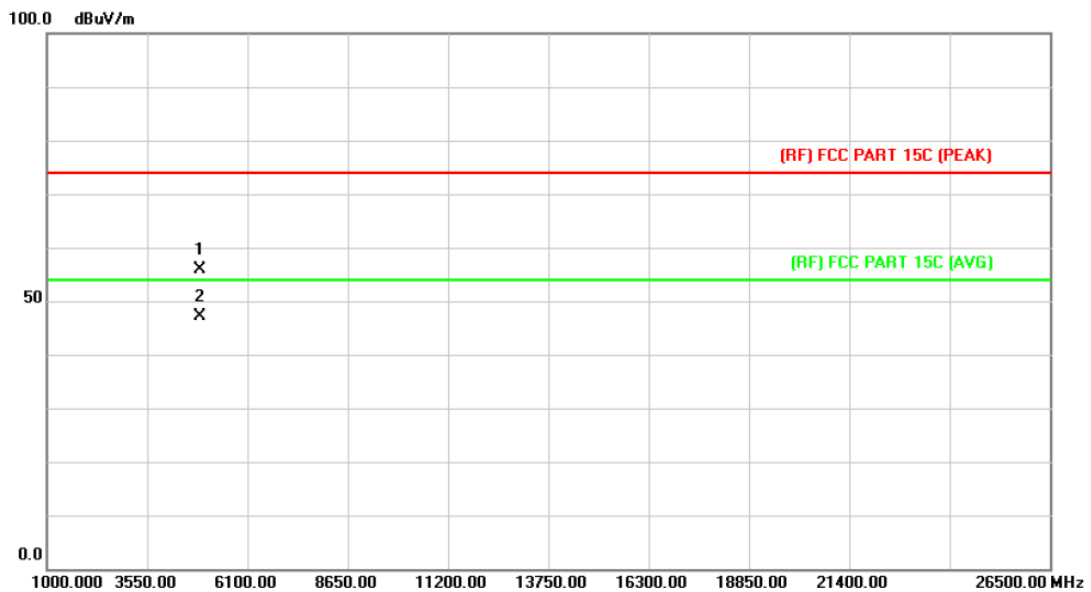

No.	Mk.	Freq.	Reading Level	Correct Factor	Measurement	Limit	Over	Detector
		MHz	dBuV	dB/m	dBuV/m	dBuV/m	dB	
1		4880.010	41.87	13.89	55.76	74.00	-18.24	peak
2	*	4880.010	33.36	13.89	47.25	54.00	-6.75	AVG

Emission Level= Read Level+ Correct Factor

EUT:	Silicone Waterproof Laser Mouse	Model Name :	TE-WM03
Temperature:	25 °C	Relative Humidity:	55%
Test Voltage:	DC 3.0V		
Ant. Pol.	Vertical		
Test Mode:	TX FSK Mode 2440MHz		
Remark:	No report for the emission which more than 10 dB below the prescribed limit.		

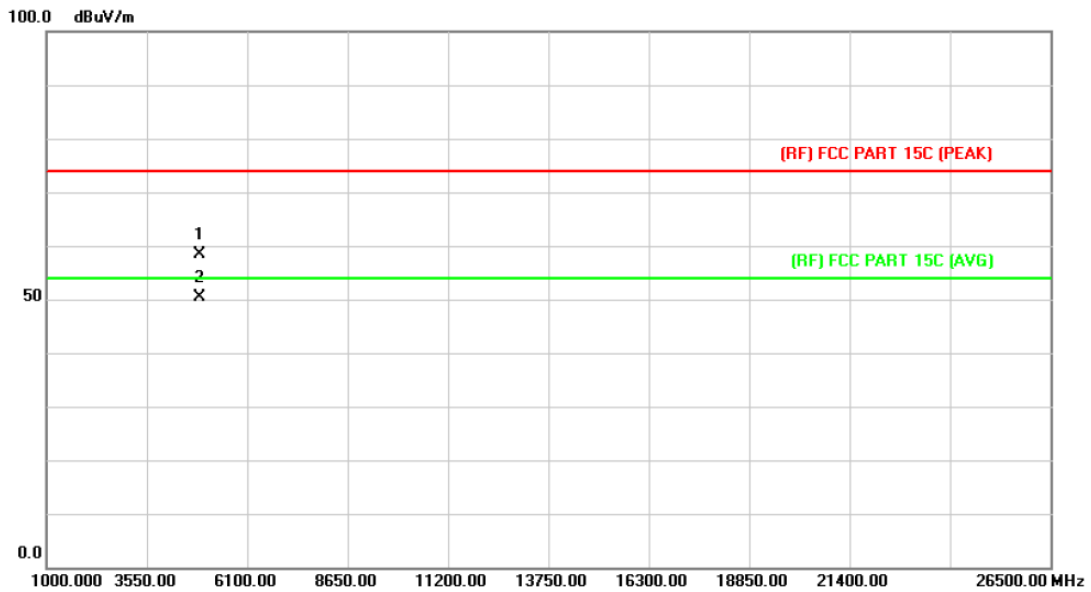

No.	Mk.	Freq. MHz	Reading Level dBuV	Correct Factor dB/m	Measure- ment dBuV/m	Limit dBuV/m	Over dB	Detector
1		4880.010	44.52	13.89	58.41	74.00	-15.59	peak
2	*	4880.010	36.47	13.89	50.36	54.00	-3.64	AVG

Emission Level= Read Level+ Correct Factor

EUT:	Silicone Waterproof Laser Mouse	Model Name :	TE-WM03
Temperature:	25 °C	Relative Humidity:	55%
Test Voltage:	DC 3.0V		
Ant. Pol.	Horizontal		
Test Mode:	TX FSK Mode 2480MHz		
Remark:	No report for the emission which more than 10 dB below the prescribed limit.		

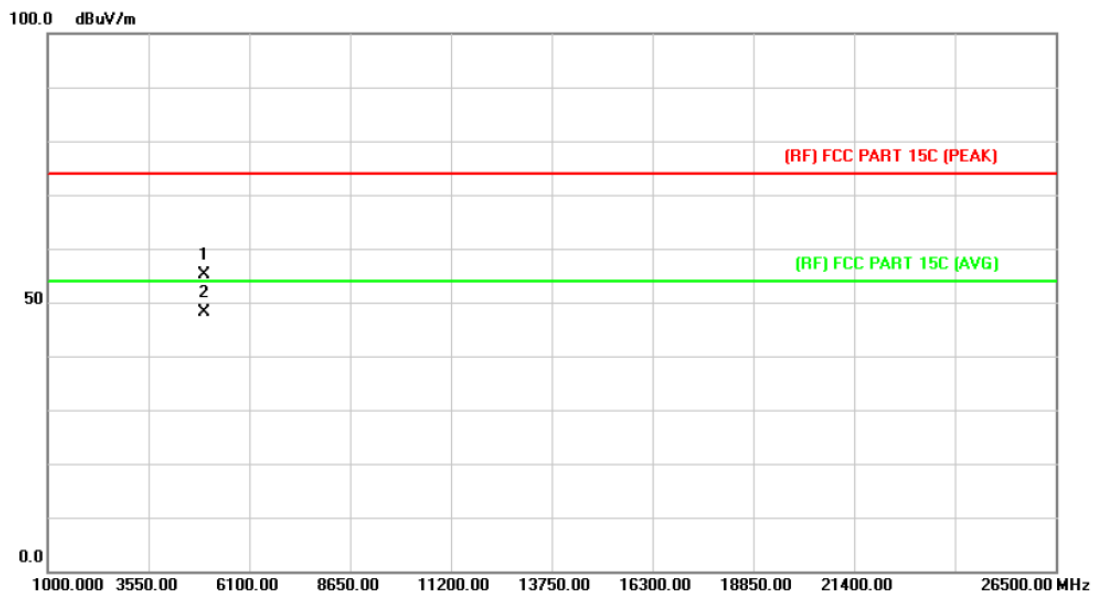

No.	Mk.	Freq. MHz	Reading Level dBuV	Correct Factor dB/m	Measure- ment dBuV/m	Limit dBuV/m	Over dB	Detector
1		4959.990	40.71	14.36	55.07	74.00	-18.93	peak
2	*	4959.990	33.67	14.36	48.03	54.00	-5.97	AVG

Emission Level= Read Level+ Correct Factor

EUT:	Silicone Waterproof Laser Mouse	Model Name :	TE-WM03
Temperature:	25 °C	Relative Humidity:	55%
Test Voltage:	DC 3.0V		
Ant. Pol.	Vertical		
Test Mode:	TX FSK Mode 2480MHz		
Remark:	No report for the emission which more than 10 dB below the prescribed limit.		

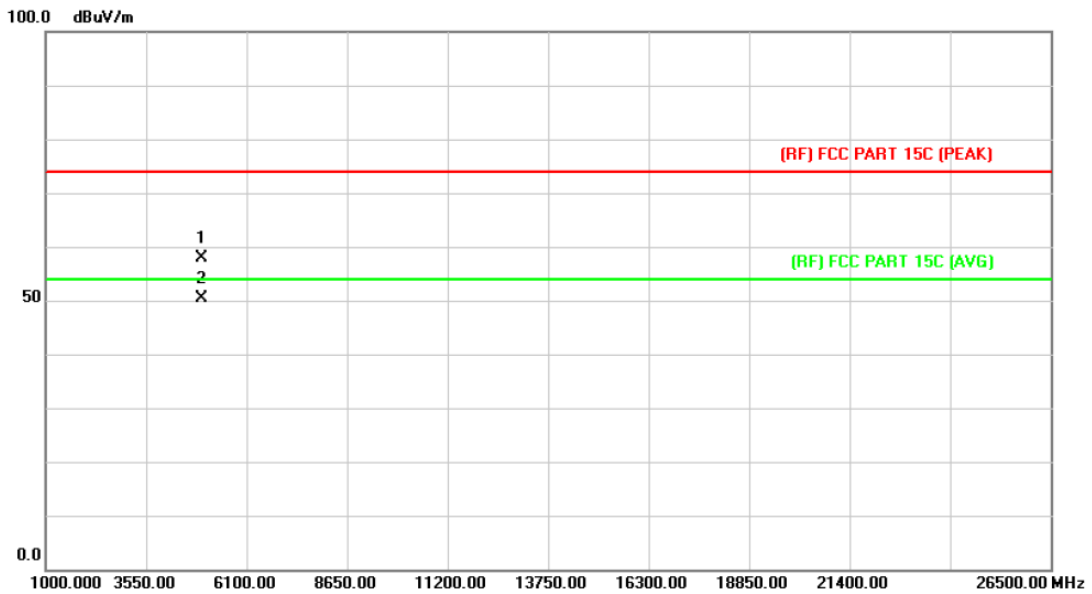

No.	Mk.	Freq.	Reading Level	Correct Factor	Measurement	Limit	Over	Detector
		MHz	dBuV	dB/m	dBuV/m	dBuV/m	dB	
1		4959.990	43.59	14.36	57.95	74.00	-16.05	peak
2	*	4959.990	36.00	14.36	50.36	54.00	-3.64	AVG

Emission Level= Read Level+ Correct Factor

5. Restricted Bands Requirement

5.1 Test Standard and Limit

5.1.1 Test Standard

FCC Part 15.209

FCC Part 15.205

5.1.2 Test Limit

Restricted Frequency Band (MHz)	Class B (dBuV/m)(at 3 M)
2310~2390	Attenuated by at least 50 dB below the level of the fundamental or to the general radiated emission limits in 15.209, whichever is the lesser attenuation
2483.5~2500	

Limits of Field Strength of Fundamental (15.249)

FCC Part 15 (15.249), Subpart C		
Detector	Limit	Frequency Range (MHz)
Average	Field strength of fundamental (94 dB μ V/m) @ 3 m	2400~2483.5
Peak	Field strength of fundamental (114 dB μ V/m) @ 3 m	

5.2 Test Setup

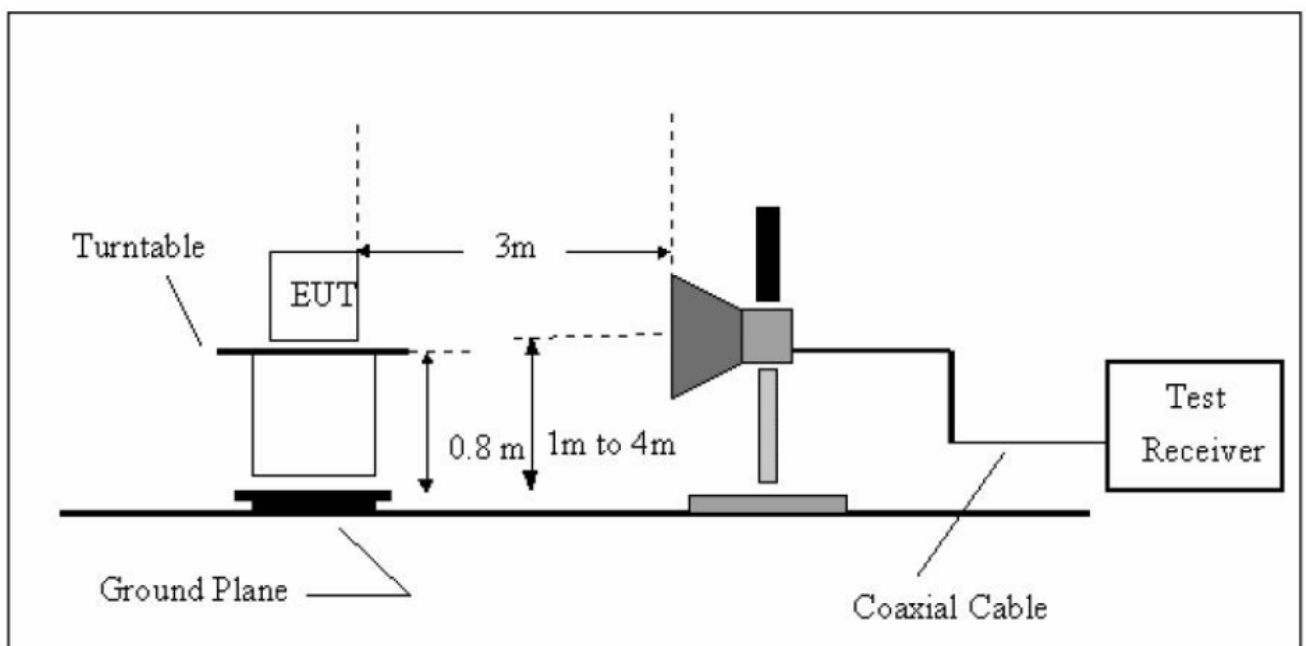

5.3 Test Procedure

- (1) The measuring distance of 3m shall be used for measurements at frequency up to 1GHz and above 1 GHz. The EUT was placed on a rotating 0.8m high above ground, the table was rotated 360 degrees to determine the position of the highest radiation.
- (2) The Test antenna shall vary between 1m and 4m, Both Horizontal and Vertical antenna are set to make measurement.
- (3) The initial step in collecting conducted emission data is a spectrum analyzer peak detector mode pre-scanning the measurement frequency range. Significant peaks are then marked and then Quasi Peak detector mode re-measured.
- (4) If the Peak Mode measured value compliance with and lower than Quasi Peak Mode Limit Bellow 1 GHz, the EUT shall be deemed to meet QP Limits and then no additional QP Mode measurement performed. But the Peak Value and average value both need to comply with applicable limit above 1 GHz.
- (5) For the actual test configuration, please see the test setup photo.

5.4 EUT Operating Condition

The Equipment Under Test was set to Continual Transmitting in maximum power.

5.5 Test Equipment

Equipment	Manufacturer	Model No.	Serial No.	Last Cal.	Cal. Due Date
Spectrum Analyzer	Agilent	E4407B	MY45106456	Mar. 20, 2014	Mar. 19, 2015
Spectrum Analyzer	Rohde & Schwarz	FSP30	DE25181	Aug. 10, 2013	Aug.09, 2014
EMI Test Receiver	Rohde & Schwarz	ESCI	101165	Aug. 10, 2013	Aug.09, 2014
Bilog Antenna	ETS-LINDGREN	3142E	00117537	Mar. 07, 2014	Mar.06, 2015
Horn Antenna	ETS-LINDGREN	3117	00143207	Mar. 07, 2014	Mar.06, 2015
Pre-amplifier	HP	11909A	185903	Mar. 07, 2014	Mar.06, 2015
Pre-amplifier	HP	8447B	3008A00849	Mar. 07, 2014	Mar.06, 2015
Cable	HUBER+SUHNER	100	SUCOFLEX	Mar. 07, 2014	Mar.06, 2015
Signal Generator	Rohde & Schwarz	SML03	IKW682-054	Feb. 11, 2014	Feb.10, 2015
Positioning Controller	ETS-LINDGREN	2090	N/A	N/A	N/A

5.6 Test Data

Remark: During testing above 1GHz the measuring instrument use RBW=1 MHz and VBW=3 MHz with Peak Detector for Peak Values, and use RBW=1 MHz and VBW=10 Hz

with Peak Detector for Average Values.
 Test data please refer the following pages.

EUT:	Silicone Waterproof Laser Mouse	Model Name :	TE-WM03
Temperature:	25 °C	Relative Humidity:	55%
Test Voltage:	DC 3.0V		
Ant. Pol.	Horizontal		
Test Mode:	TX FSK Mode 2402MHz		
Remark:	N/A		

No.	Mk.	Freq.	Reading Level	Correct Factor	Measurement	Limit	Over	Antenna Height	Table Degree	Comment
		MHz	dBuV	dB/m	dBuV/m	dBuV/m	dB	cm	degree	
1		2390.000	42.89	0.77	43.66	74.00	-30.34	peak	112	274
2		2390.000	31.63	0.77	32.40	54.00	-21.60	AVG		
3	X	2402.040	84.84	0.82	85.66	74.00	11.66	peak	112	274
4	*	2402.040	84.61	0.82	85.43	54.00	31.43	AVG		FUNDAMENTAL FREQUENCY

Emission Level= Read Level+ Correct Factor
 Fundamental Frequency Limits: Peak= 114 dBuV/m/ AVG= 94 dBuV/m

EUT:	Silicone Waterproof Laser Mouse	Model Name :	TE-WM03
Temperature:	25 °C	Relative Humidity:	55%
Test Voltage:	DC 3.0V		
Ant. Pol.	Vertical		
Test Mode:	TX FSK Mode 2402MHz		
Remark:	N/A		

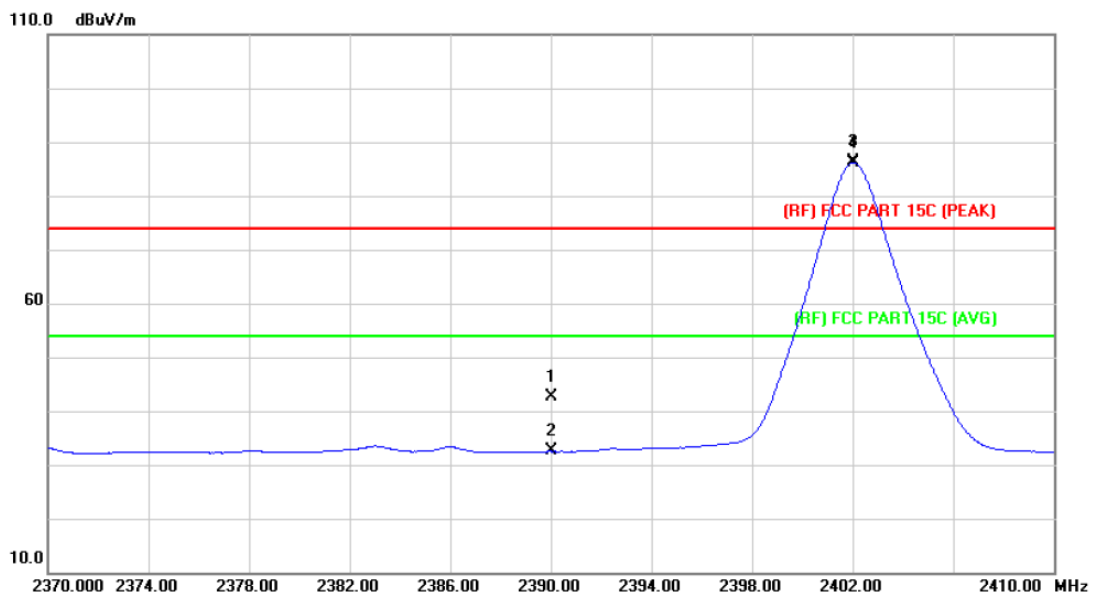

No.	Mk.	Freq.	Reading Level	Correct Factor	Measurement	Limit	Over	Antenna Height	Table Degree	Comment
		MHz	dBuV	dB/m	dBuV/m	dBuV/m	dB	cm	degree	
1		2390.000	41.96	0.77	42.73	74.00	-31.27	peak	104	0
2		2390.000	31.74	0.77	32.51	54.00	-21.49	AVG		
3	X	2402.000	85.57	0.82	86.39	74.00	12.39	peak	104	0
4	*	2402.000	85.35	0.82	86.17	54.00	32.17	AVG		FUNDAMENTAL FREQUENCY

Emission Level= Read Level+ Correct Factor

Fundamental Frequency Limits: Peak= 114 dBuV/m/ AVG= 94 dBuV/m

EUT:	Silicone Waterproof Laser Mouse	Model Name :	TE-WM03
Temperature:	25 °C	Relative Humidity:	55%
Test Voltage:	DC 3.0V		
Ant. Pol.	Horizontal		
Test Mode:	TX FSK Mode 2440MHz		
Remark:	N/A		

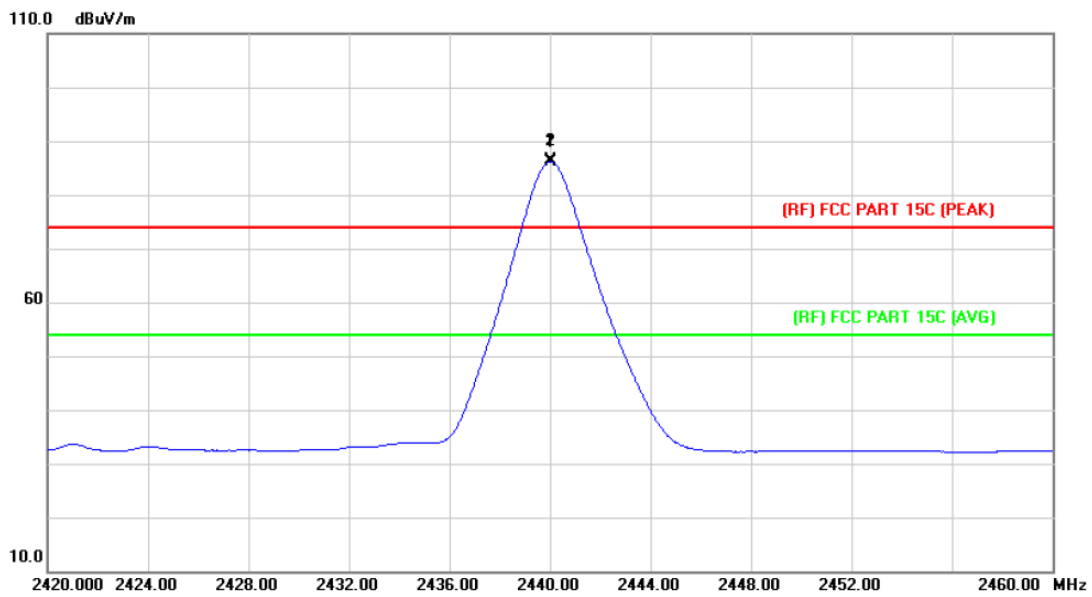

No.	Mk.	Freq.	Reading Level	Correct Factor	Measurement	Limit	Over	Antenna Height	Table Degree	Comment
		MHz	dBuV	dB/m	dBuV/m	dBuV/m	dB	cm	degree	
1	*	2440.000	85.16	0.98	86.14	54.00	32.14	AVG		FUNDAMENTAL FREQUENCY
2	X	2440.040	85.41	0.98	86.39	74.00	12.39	peak	103	32 FUNDAMENTAL FREQUENCY

Emission Level= Read Level+ Correct Factor

Fundamental Frequency Limits: Peak= 114 dBuV/m/ AVG= 94 dBuV/m

EUT:	Silicone Waterproof Laser Mouse	Model Name :	TE-WM03
Temperature:	25 °C	Relative Humidity:	55%
Test Voltage:	DC 3.0V		
Ant. Pol.	Vertical		
Test Mode:	TX FSK Mode 2440MHz		
Remark:	N/A		

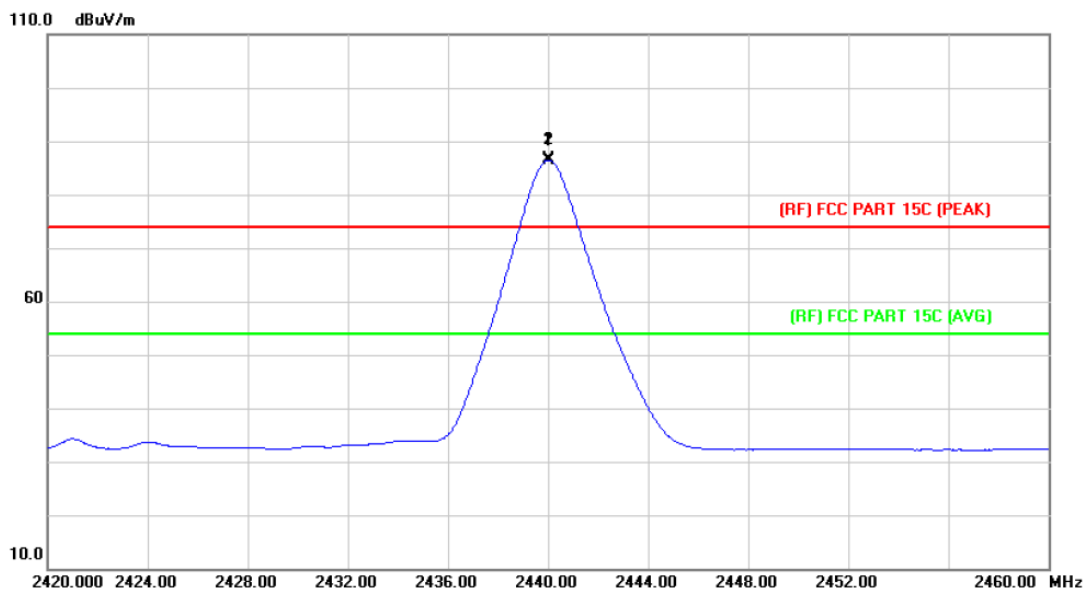

No.	Mk.	Freq.	Reading Level	Correct Factor	Measurement	Limit	Over	Antenna Height	Table Degree	Comment
		MHz	dBuV	dB/m	dBuV/m	dBuV/m	dB	cm	degree	
1	*	2440.000	85.49	0.98	86.47	54.00	32.47	AVG		FUNDAMENTAL FREQUENCY
2	X	2440.040	85.72	0.98	86.70	74.00	12.70	peak	111	353 FUNDAMENTAL FREQUENCY

Emission Level= Read Level+ Correct Factor

Fundamental Frequency Limits: Peak= 114 dBuV/m/ AVG= 94 dBuV/m

EUT:	Silicone Waterproof Laser Mouse	Model Name :	TE-WM03
Temperature:	25 °C	Relative Humidity:	55%
Test Voltage:	DC 3.0V		
Ant. Pol.	Horizontal		
Test Mode:	TX FSK Mode 2480MHz		
Remark:	N/A		

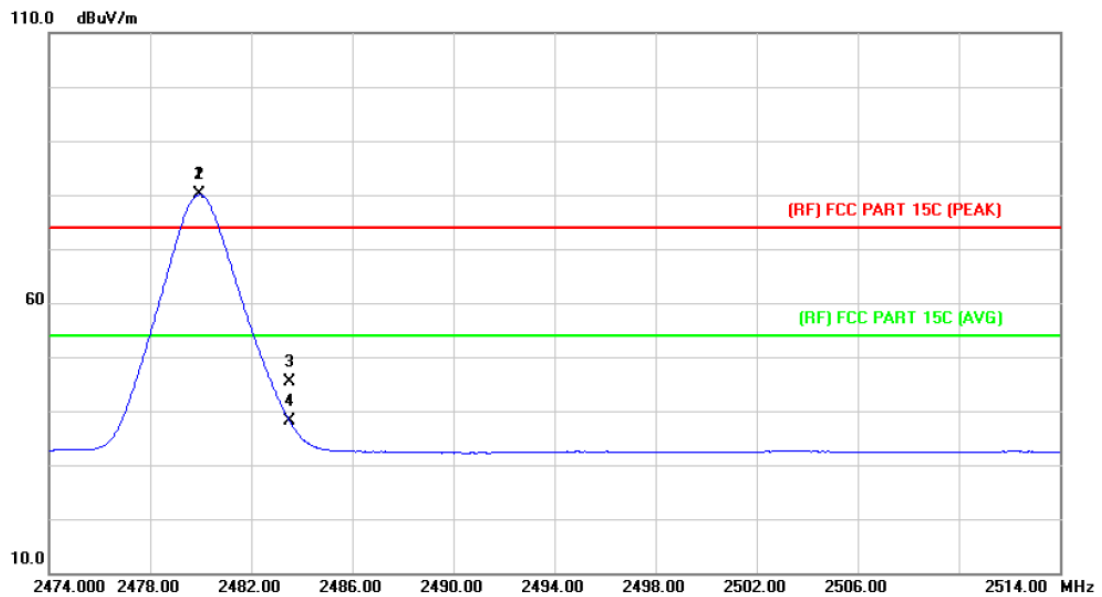

No.	Mk.	Freq. MHz	Reading Level dBuV	Correct Factor dB/m	Measurement dBuV/m	Limit dBuV/m	Over dB	Detector	Antenna Height cm	Table Degree degree	Comment
1	X	2479.960	79.07	1.15	80.22	74.00	6.22	peak	169	360	FUNDAMENTAL FREQUENCY
2	*	2479.960	78.88	1.15	80.03	54.00	26.03	AVG			FUNDAMENTAL FREQUENCY
3		2483.500	44.15	1.17	45.32	74.00	-28.68	peak	169	360	
4		2483.500	36.94	1.17	38.11	54.00	-15.89	AVG			

Emission Level= Read Level+ Correct Factor

Fundamental Frequency Limits: Peak= 114 dBuV/m/ AVG= 94 dBuV/m

EUT:	Silicone Waterproof Laser Mouse	Model Name :	TE-WM03
Temperature:	25 °C	Relative Humidity:	55%
Test Voltage:	DC 3.0V		
Ant. Pol.	Vertical		
Test Mode:	TX FSK Mode 2480MHz		
Remark:	N/A		

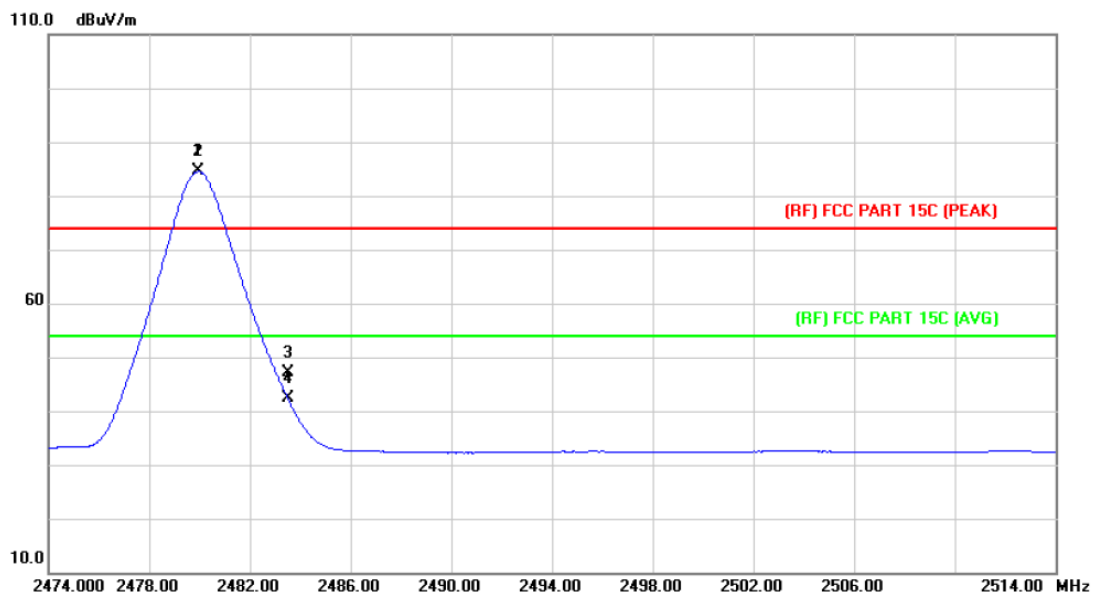

No.	Mk.	Freq. MHz	Reading Level dBuV	Correct Factor dB/m	Measure- ment dBuV/m	Limit dBuV/m	Over dB	Detector	Antenna Height cm	Table Degree	Comment
1	X	2479.960	83.57	1.15	84.72	74.00	10.72	peak	105	182	FUNDAMENTAL FREQUENCY
2	*	2479.960	83.38	1.15	84.53	54.00	30.53	AVG			FUNDAMENTAL FREQUENCY
3		2483.500	45.88	1.17	47.05	74.00	-26.95	peak	105	182	
4		2483.500	41.10	1.17	42.27	54.00	-11.73	AVG			

Emission Level= Read Level+ Correct Factor

Fundamental Frequency Limits: Peak= 114 dBuV/m/ AVG= 94 dBuV/m

6. Bandwidth Test

6.1 Test Setup

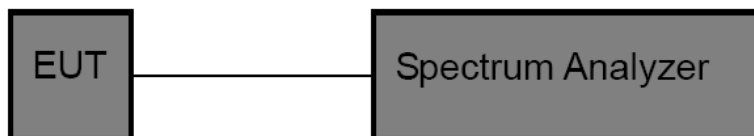

6.2 Test Procedure

- (1) The EUT was directly connected to the spectrum analyzer and antenna output port as show in the block diagram above.
- (2) Spectrum Setting:
Bandwidth: RBW=100 kHz, VBW=300kHz.
- (3) The bandwidth is measured at an amplitude level reduced 20dB from the reference level. The reference level is the level of the highest amplitude signal observed from the transmitter at the fundamental frequency. Once the reference level is established, the equipment is conditioned with typical modulating signal to produce the worst –case (i.e the widest) bandwidth.

6.3 EUT Operating Condition

The EUT was set to continuously transmitting for the Bandwidth Test.

6.4 Test Equipment

Equipment	Manufacturer	Model No.	Serial No.	Last Cal.	Cal. Due Date
Spectrum Analyzer	Agilent	E4407B	MY45106456	Mar. 20, 2014	Mar. 19, 2015

6.5 Test Data

Low Channel Frequency (MHz)	20dB Bandwidth (kHz)
2402	308.00

2402 MHz

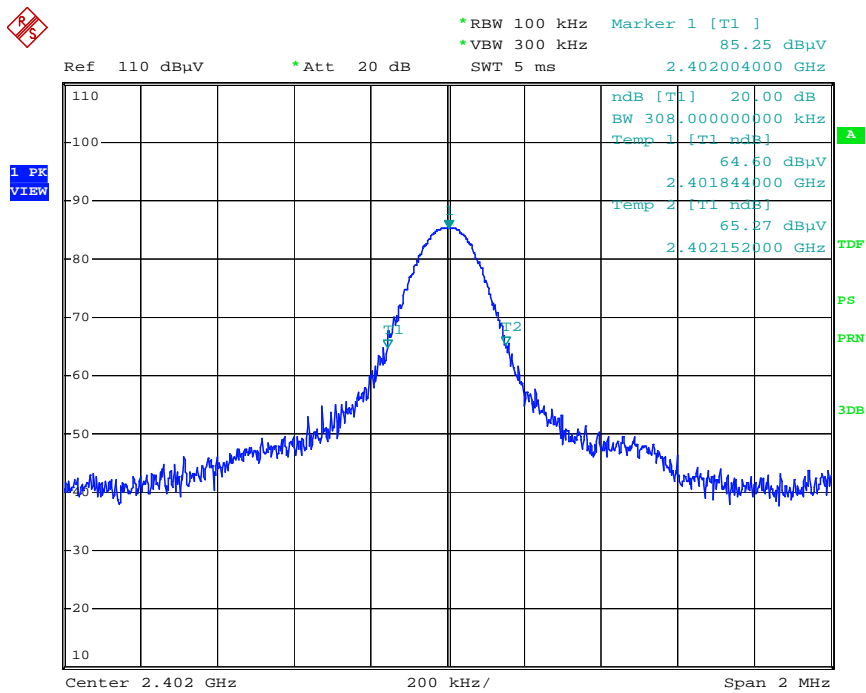

Date: 13.AUG.2014 10:41:17

Middle Channel Frequency (MHz)	20dB Bandwidth (kHz)
2440	298.00

2440 MHz

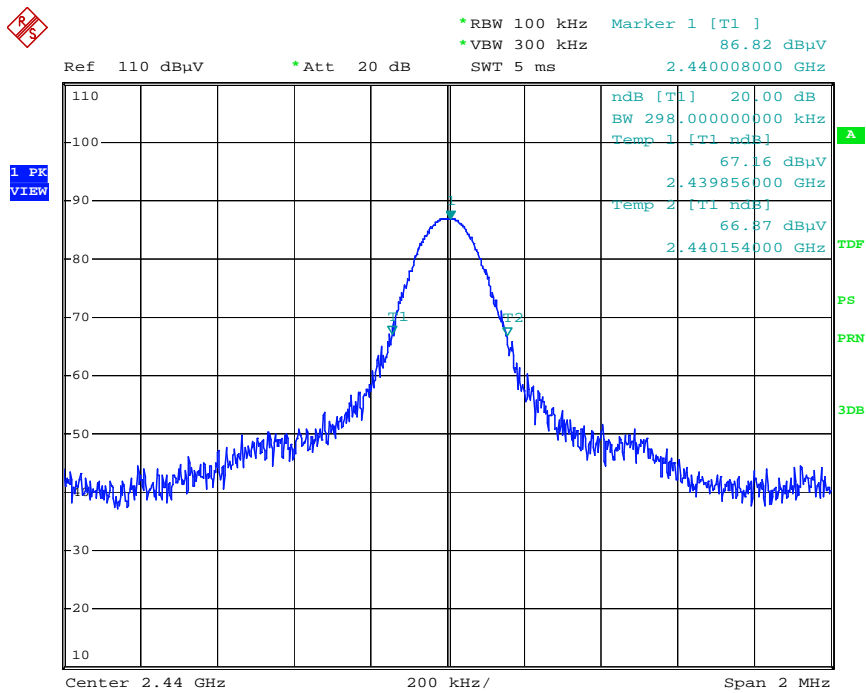

Date: 13.AUG.2014 10:34:34

High Channel Frequency (MHz)	20dB Bandwidth (MHz)
2480	298.00

2482 MHz

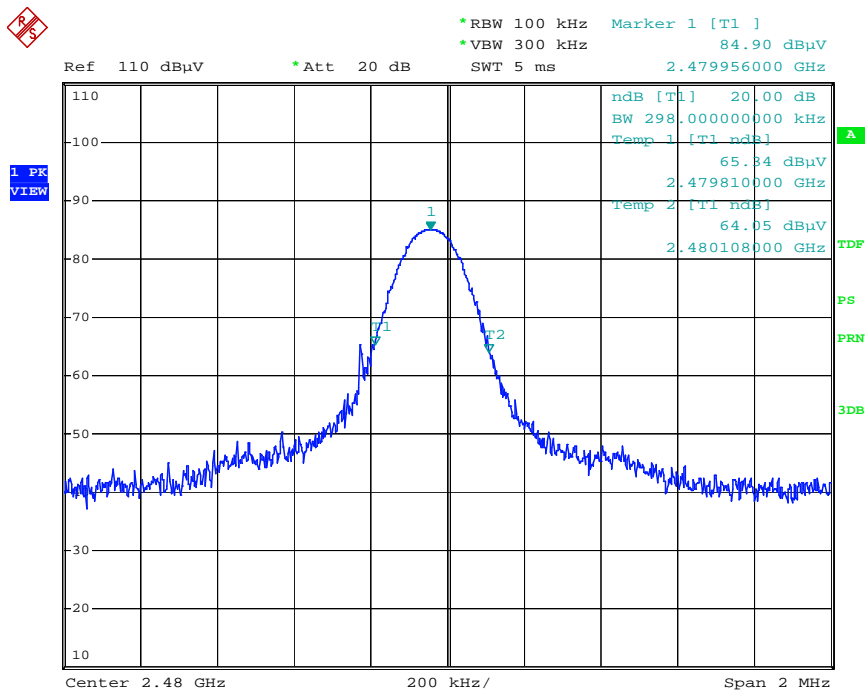

Date: 13.AUG.2014 10:39:35

7. Antenna Requirement

7.1 Standard Requirement

7.1.1 Standard

FCC Part 15.203

7.1.2 Requirement

An intentional radiator shall be designed to ensure that no antenna other than that furnished by the responsible party shall be used with the device. The use of a permanently attached antenna or of an antenna that uses a unique coupling to the intentional radiator shall be considered sufficient to comply with the provisions of this Section. The manufacturer may design the unit so that a broken antenna can be replaced by the user, but the use of a standard antenna jack or electrical connector is prohibited.

7.2 Antenna Connected Construction

The directional gains of the antenna used for transmitting is 0 dBi, and the antenna de-signed with permanent attachment and no consideration of replacement. Please see the EUT photo for details.

7.3 Result

The EUT antenna is a Printed Antenna. It complies with the standard requirement.