



FCC RADIO TEST REPORT

FCC ID:2ACVKKC-KBR101U

Product : Dual-model RF & Bluetooth keyboard with touchpad

Trade Name : N/A

Model Name : KC-KBR101

Serial Model : N/A

Report No. : NTEK-2014NT0618929F3

Prepared for

Kano Computing Limited

69-89 Mile End Road, London, E1 4TT, United Kingdom

Prepared by

Shenzhen NTEK Testing Technology Co., Ltd.

1/F, Building E, Fenda Science Park, Sanwei Community, Xixiang Street
Bao'an District, Shenzhen P.R. China

Tel.: +86-0755-61156588 Fax.: +86-0755-61156599

Website: www.ntek.org.cn

TEST RESULT CERTIFICATION

Applicant's name : Kano Computing Limited
Address : 69-89 Mile End Road, London, E1 4TT, United Kingdom
Manufacturer's Name..... : Shenzhen Riitek Technology CO.,Ltd.
Address : A1-4,A Zone,Baoyunda Logistic Center, Avenue Xixiang, BaoAn District, Shenzhen,China

Product description

Product name : Dual-model RF & Bluetooth keyboard with touchpad
Model and/or type reference : KC-KBR101
Serial Model : N/A
Rating(s)..... : DC 5V

Standards : FCC Part15.249 01 Oct. 2013

Test procedure..... ANSI C63.4-2003

This device described above has been tested by NTEK, and the test results show that the equipment under test (EUT) is in compliance with the FCC requirements. And it is applicable only to the tested sample identified in the report.

This report shall not be reproduced except in full, without the written approval of NTEK, this document may be altered or revised by NTEK, personal only, and shall be noted in the revision of the document.

Date of Test :
Date (s) of performance of tests : 18 Jun. 2014 ~10 Jul. 2014
Date of Issue..... : 10 Jul. 2014
Test Result..... : **Pass**

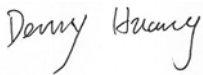
Testing Engineer : 
Denny Huang

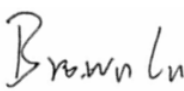
Technical Manager : 
(Brown Lu)

Authorized Signatory : 
(Bill Yao)

Table of Contents

Page

1 . SUMMARY OF TEST RESULTS	4
1.1 TEST FACILITY	5
1.2 MEASUREMENT UNCERTAINTY	5
2 . GENERAL INFORMATION	6
2.1 GENERAL DESCRIPTION OF EUT	6
2.2 DESCRIPTION OF TEST MODES	8
2.3 BLOCK DIGRAM SHOWING THE CONFIGURATION OF SYSTEM TESTED	9
2.4 DESCRIPTION OF SUPPORT UNITS(CONDUCTED MODE)	10
2.5 EQUIPMENTS LIST FOR ALL TEST ITEMS	11
3 . ANTENNA REQUIREMENT	12
3.1 STANDARD REQUIREMENT	12
3.2 EUT ANTENNA	12
3.3 CONDUCTED EMISSION MEASUREMENT	13
3.3.1 POWER LINE CONDUCTED EMISSION LIMITS	13
3.3.2 TEST PROCEDURE	14
3.3.3 DEVIATION FROM TEST STANDARD	14
3.3.4 TEST SETUP	14
3.2.5 TEST RESULT	15
3.4 RADIATED EMISSION MEASUREMENT	17
3.4.1 RADIATED EMISSION LIMITS	17
3.4.2 TEST PROCEDURE	18
3.4.3 DEVIATION FROM TEST STANDARD	18
3.4.4 TEST SETUP	19
3.4.5 TEST RESULTS (BLOW 30MHZ)	21
3.4.6 TEST RESULTS (BETWEEN 30 – 1000 MHZ)	22
3.4.7 TEST RESULTS (ABOVE 1000 MHZ)	24
3.4.8 TEST RESULTS (RESTRICTED BANDS REQUIREMENTS)	30
4 . BANDWIDTH TEST	34
4.1 TEST PROCEDURE	34
4.2 DEVIATION FROM STANDARD	34
4.3 TEST SETUP	34
4.4 TEST RESULTS	35
5 . EUT TEST PHOTO	37
APPENDIX-PHOTOGRAPHS OF EUT CONSTRUCTIONAL DETAILS	

1. SUMMARY OF TEST RESULTS

Test procedures according to the technical standards:

FCC Part15, Subpart C (15.249)			
Standard Section	Test Item	Judgment	Remark
15.207	Conducted Emission	Pass	
15.203	Antenna Requirement	Pass	
15.249	Radiated Spurious Emission	Pass	
15.205	Band Edge Emission	Pass	
15.249	Occupied Bandwidth	Pass	

1.1 TEST FACILITY

NTEK Testing Technology Co., Ltd

Add. : 1/F, Building E, Fenda Science Park, Sanwei Community, Xixiang Street, Bao'an District, Shenzhen P.R. China.

FCC FRN Registration No.:238937; IC Registration No.:9270A-1

CNAS Registration No.:L5516

1.2 MEASUREMENT UNCERTAINTY

The reported uncertainty of measurement $y \pm U$, where expanded uncertainty U is based on a standard uncertainty multiplied by a coverage factor of $k=2$, providing a level of confidence of approximately **95 %**.

No.	Item	Uncertainty
1	Conducted Emission Test	$\pm 1.38\text{dB}$
2	RF power,conducted	$\pm 0.16\text{dB}$
3	Spurious emissions,conducted	$\pm 0.21\text{dB}$
4	All emissions,radiated(<1G)	$\pm 4.68\text{dB}$
5	All emissions,radiated(>1G)	$\pm 4.89\text{dB}$
6	Temperature	$\pm 0.5^\circ\text{C}$
7	Humidity	$\pm 2\%$

2. GENERAL INFORMATION

2.1 GENERAL DESCRIPTION OF EUT

Equipment	Dual-model RF & Bluetooth keyboard with touchpad
Trade Name	N/A
Model Name	KC-KBR101
Serial Model	N/A
Model Difference	N/A
Product Description	The EUT is a Dual-model RF & Bluetooth keyboard with touchpad
	Operation Frequency: 2401MHz-2480MHz
	Modulation Type: GFSK
	Antenna Designation: PCB Antenna
	Antenna Gain(Peak) 1.0 dBi
	EIRP 82.00dBuv/m@3m
	Based on the application, features, or specification exhibited in User's Manual, the EUT is considered as an ITE/Computing Device. More details of EUT technical specification, please refer to the User's Manual.
Channel List	Please refer to the Note 2.
Adapter	N/A
Battery	N/A

Note:

1. For a more detailed features description, please refer to the manufacturer's specifications or the User's Manual.

2.

Channel	Frequency (MHz)
01	2401
02	2407
03	2410
04	2414
05	2421
06	2428
07	2435
08	2437
09	2440
10	2441
11	2442
12	2467
13	2468
14	2480

3.

Table for Filed Antenna

Ant .	Brand	Model Name	Antenna Type	Connector	Gain (dBi)	NOTE
1	N/A	N/A	PCB Antenna	N/A	1.0	Antenna

2.2 DESCRIPTION OF TEST MODES

To investigate the maximum EMI emission characteristics generates from EUT, the test system was pre-scanning tested base on the consideration of following EUT operation mode or test configuration mode which possible have effect on EMI emission level. Each of these EUT operation mode(s) or test configuration mode(s) mentioned above was evaluated respectively.

Pretest Mode	Description
Mode 1	Link Mode
Mode 2	TX CH 01
Mode 3	TX CH 09
Mode 4	TX CH 14

For Conducted Emission	
Final Test Mode	Description
Mode 1	Link Mode

For Radiated Emission	
Final Test Mode	Description
Mode 1	Link Mode
Mode 2	TX CH 01
Mode 3	TX CH 09
Mode 4	TX CH 14

Note:

- (1) The measurements are performed at the highest, middle, lowest available channels.
- (2) The EUT use new battery.

2.3 BLOCK DIGRAM SHOWING THE CONFIGURATION OF SYSTEM TESTED

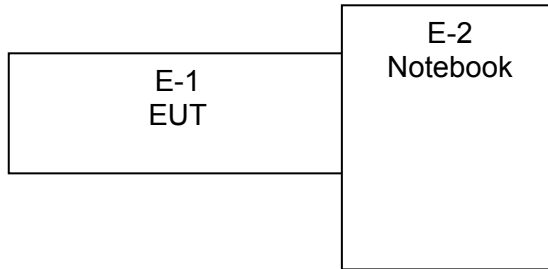

2.4 DESCRIPTION OF SUPPORT UNITS(CONDUCTED MODE)

The EUT has been tested as an independent unit together with other necessary accessories or support units. The following support units or accessories were used to form a representative test configuration during the tests.

Item	Equipment	Mfr/Brand	Model/Type No.	Series No.	Note
E-1	Dual-model RF & Bluetooth keyboard with touchpad	N/A	KC-KBR101	N/A	EUT
E-2	Notebook	DELL	PP10L	N/A	

Item	Shielded Type	Ferrite Core	Length	Note

Note:

- (1) The support equipment was authorized by Declaration of Confirmation.
- (2) For detachable type I/O cable should be specified the length in cm in 『Length』 column.

2.5 EQUIPMENTS LIST FOR ALL TEST ITEMS
Radiation Test equipment

Radiation Test equipment

Item	Kind of Equipment	Manufacturer	Type No.	Serial No.	Last calibration	Calibrated until	Calibration period
1	Spectrum Analyzer	Agilent	E4407B	MY45108040	2013.07.06	2014.07.05	1 year
1	Spectrum Analyzer	Agilent	E4407B	MY45108040	2014.07.06	2015.07.05	1 year
2	Test Receiver	R&S	ESPI	101318	2014.06.07	2015.06.06	1 year
3	Bilog Antenna	TESEQ	CBL6111D	31216	2013.07.06	2014.07.05	1 year
3	Bilog Antenna	TESEQ	CBL6111D	31216	2014.07.06	2015.07.05	1 year
4	50Ω Coaxial Switch	Anritsu	MP59B	6200264416	2014.06.07	2015.06.06	1 year
5	Spectrum Analyzer	ADVANTEST	R3132	150900201	2014.06.07	2015.06.06	1 year
6	Horn Antenna	EM	EM-AH-10180	2011071402	2013.07.06	2014.07.05	1 year
6	Horn Antenna	EM	EM-AH-10180	2011071402	2014.07.06	2015.07.05	1 year
7	Horn Ant	Schwarzbeck	BBHA 9170	9170-181	2013.07.06	2014.07.05	1 year
7	Horn Ant	Schwarzbeck	BBHA 9170	9170-181	2014.07.06	2015.07.05	1 year
8	Amplifier	EM	EM-30180	060538	2013.12.22	2014.12.21	1 year
9	Loop Antenna	ARA	PLA-1030/B	1029	2014.06.08	2015.06.07	1 year
10	Power Meter	R&S	NRVS	100696	2013.07.06	2014.07.05	1 year
10	Power Meter	R&S	NRVS	100696	2014.07.06	2015.07.05	1 year
11	Power Sensor	R&S	URV5-Z4	0395.1619.05	2013.07.06	2014.07.05	1 year
11	Power Sensor	R&S	URV5-Z4	0395.1619.05	2014.07.06	2015.07.05	1 year

Conduction Test equipment

Item	Kind of Equipment	Manufacturer	Type No.	Serial No.	Last calibration	Calibrated until	Calibration period
1	Test Receiver	R&S	ESCI	101160	2014.06.06	2015.06.05	1 year
2	LISN	R&S	ENV216	101313	2013.08.24	2014.08.23	1 year
3	LISN	EMCO	3816/2	00042990	2013.08.24	2014.08.23	1 year
4	50Ω Coaxial Switch	Anritsu	MP59B	6200264417	2014.06.07	2015.06.06	1 year
5	Passive Voltage Probe	R&S	ESH2-Z3	100196	2014.06.07	2015.06.06	1 year
6	Absorbing clamp	R&S	MOS-21	100423	2014.06.08	2015.06.07	1 year

1	Attenuation	MCE	24-10-34	BN9258	2014.06.08	2015.06.07	1 year
---	-------------	-----	----------	--------	------------	------------	--------

3. ANTENNA REQUIREMENT

3.1 STANDARD REQUIREMENT

15.203 requirement: For intentional device, according to 15.203: an intentional radiator shall be designed to ensure that no antenna other than that furnished by the responsible party shall be used with the device.

3.2 EUT ANTENNA

The EUT antenna is PCB Antenna. It comply with the standard requirement.

3.3 CONDUCTED EMISSION MEASUREMENT

3.3.1 POWER LINE CONDUCTED EMISSION Limits (Frequency Range 150KHz-30MHz)

FREQUENCY (MHz)	Class A (dBuV)		Class B (dBuV)		Standard
	Quasi-peak	Average	Quasi-peak	Average	
0.15 -0.5			66 - 56 *	56 - 46 *	CISPR
0.50 -5.0			56.00	46.00	CISPR
5.0 -30.0			60.00	50.00	CISPR

0.15 -0.5			66 - 56 *	56 - 46 *	LP002.
0.50 -5.0			56.00	46.00	LP002.
5.0 -30.0			60.00	50.00	LP002.

Note:

- (1) The tighter limit applies at the band edges.
- (2) The limit of " * " marked band means the limitation decreases linearly with the logarithm of the frequency in the range.

The following table is the setting of the receiver

Receiver Parameters	Setting
Attenuation	10 dB
Start Frequency	0.15 MHz
Stop Frequency	30 MHz
IF Bandwidth	9 kHz

3.3.2 TEST PROCEDURE

- a. The EUT was placed 0.4 meters from the horizontal ground plane with EUT being connected to the power mains through a line impedance stabilization network (LISN). All other support equipments powered from additional LISN(s). The LISN provide 50 Ohm/ 50uH of coupling impedance for the measuring instrument.
- b. Interconnecting cables that hang closer than 40 cm to the ground plane shall be folded back and forth in the center forming a bundle 30 to 40 cm long.
- c. I/O cables that are not connected to a peripheral shall be bundled in the center. The end of the cable may be terminated, if required, using the correct terminating impedance. The overall length shall not exceed 1 m.
- d. LISN at least 80 cm from nearest part of EUT chassis.
- e. For the actual test configuration, please refer to the related Item –EUT Test Photos.

3.3.3 DEVIATION FROM TEST STANDARD

No deviation

3.3.4 TEST SETUP

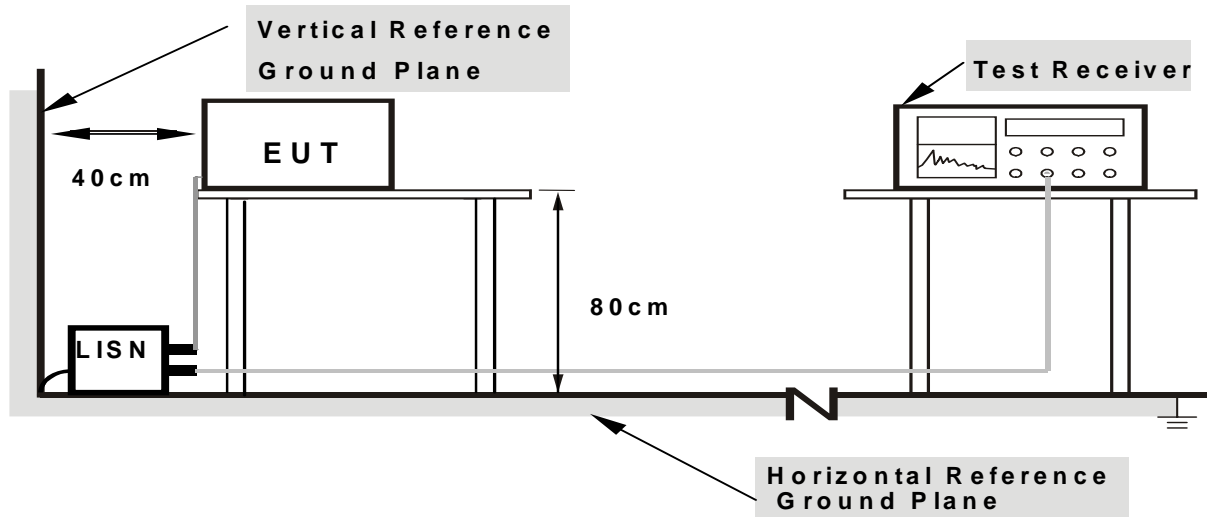

Note: 1. Support units were connected to second LISN.

2. Both of LISNs (AMN) are 80 cm from EUT and at least 80 cm from other units and other metal planes

3.2.5 TEST RESULT

EUT :	Dual-model RF & Bluetooth keyboard with touchpad	Model Name. :	KC-KBR101
Temperature :	26 °C	Relative Humidity :	54%
Pressure :	1010hPa	Phase :	L
Test Voltage :	DC 5.0V from adapter AC 120V/60Hz	Test Mode :	Mode 1

Frequency (MHz)	Reading Level (dBμV)	Correct Factor (dB)	Measure-ment (dBμV)	Limits (dBμV)	Margin (dB)	Remark
0.2419	20.82	0.00	20.82	52.03	-31.21	AVG
0.2419	31.37	0.00	31.37	62.03	-30.66	QP
0.3537	34.58	0.00	34.58	58.87	-24.29	QP
0.3537	21.37	0.00	21.37	48.87	-27.50	AVG
0.6097	39.40	0.00	39.40	56.00	-16.60	QP
0.6097	22.02	0.00	22.02	46.00	-23.98	AVG
0.7298	38.85	0.00	38.85	56.00	-17.15	QP
0.7298	21.22	0.00	21.22	46.00	-24.78	AVG
2.0779	30.16	0.00	30.16	56.00	-25.84	QP
2.0779	17.23	0.00	17.23	46.00	-28.77	AVG
3.8900	27.26	0.00	27.26	56.00	-28.74	QP
3.8900	16.61	0.00	16.61	46.00	-29.39	AVG

Remark:

1. All readings are Quasi-Peak and Average values.
2. Factor = Insertion Loss + Cable Loss.

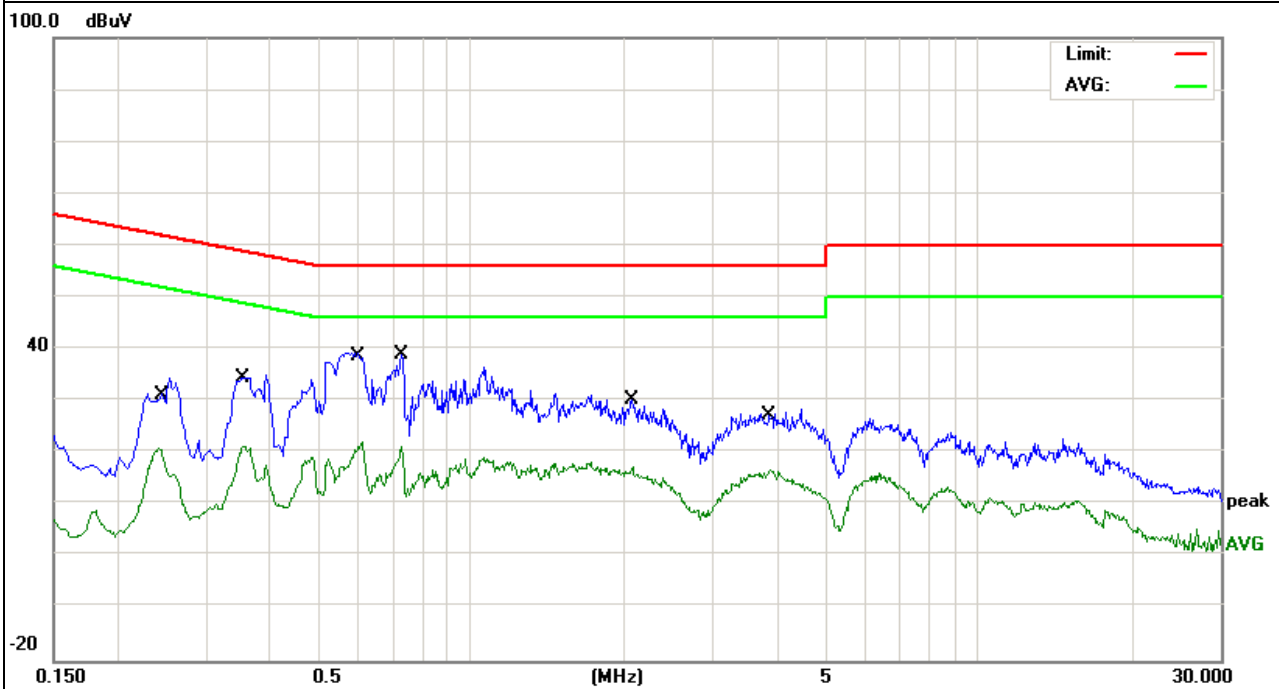

EUT :	Dual-model RF & Bluetooth keyboard with touchpad	Model Name. :	KC-KBR101
Temperature :	26 °C	Relative Humidity :	54%
Pressure :	1010hPa	Phase :	N
Test Voltage :	DC 5.0V from adapter AC 120V/60Hz	Test Mode :	Mode 1

Frequency (MHz)	Reading Level (dBμV)	Correct Factor (dB)	Measurement (dBμV)	Limits (dBμV)	Margin (dB)	Remark
0.2419	35.24	0.00	35.24	62.03	-26.79	QP
0.2419	24.30	0.00	24.30	52.03	-27.73	AVG
0.3659	33.92	0.00	33.92	58.59	-24.67	QP
0.3659	21.90	0.00	21.90	48.59	-26.69	AVG
0.4899	20.90	0.00	20.90	46.17	-25.27	AVG
0.4899	34.48	0.00	34.48	56.17	-21.69	QP
0.6097	40.35	0.00	40.35	56.00	-15.65	QP
0.6097	23.04	0.00	23.04	46.00	-22.96	AVG
1.5620	17.85	0.00	17.85	46.00	-28.15	AVG
1.5620	30.29	0.00	30.29	56.00	-25.71	QP
2.1018	30.16	0.00	30.16	56.00	-25.84	QP
2.1018	18.05	0.00	18.05	46.00	-27.95	AVG

Remark:

1. All readings are Quasi-Peak and Average values.
2. Factor = Insertion Loss + Cable Loss.

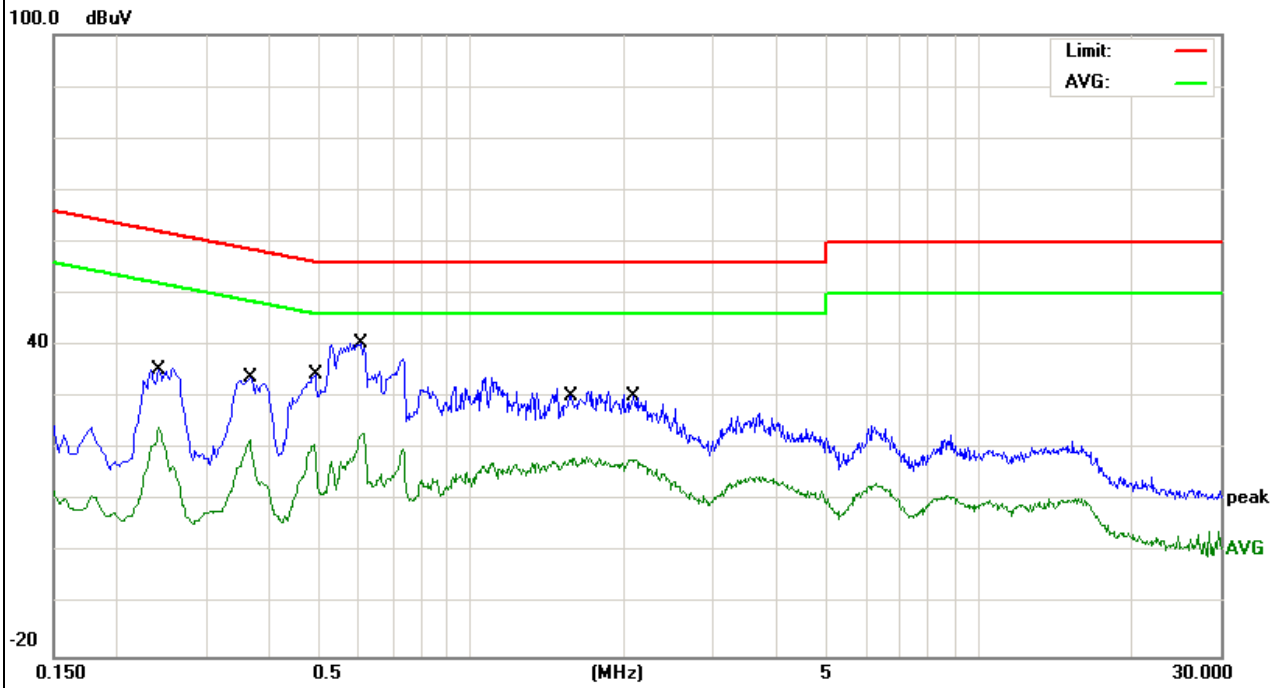

3.4 RADIATED EMISSION MEASUREMENT

3.4.1 Radiated Emission Limits (FCC 15.209)

Frequencies (MHz)	Field Strength (micorvolts/meter)	Measurement Distance (meters)
0.009~0.490	2400/F(KHz)	300
0.490~1.705	24000/F(KHz)	30
1.705~30.0	30	30
Frequency (MHz)	Limit (dBuV)	
30~88	40	3
88~216	43.5	3
216~960	46	3
960 -10000	54.00	3
*902 - 928	94.00	3

Note:

- (1) The tighter limit applies at the band edges.
- (2) Emission level (dBuV/m)=20log Emission level (uV/m).
- (3) *Note: This is the limit for the fundamental frequency.

LIMITS OF RADIATED EMISSION MEASUREMENT (FCC 15.249)

Frequency of Emission (MHz)	Field Strength of fundamental ((millivolts /meter)	Field Strength of Harmonics (microvolts/meter)
902-928	50	500

Notes:

- (1) Emissions radiated outside of the specified frequency bands, except for harmonics, shall be attenuated by at least 50 dB below the level of the fundamental or to the general radiated emission limits in Section 15.209, whichever is the lesser attenuation.

Spectrum Parameter	Setting
Attenuation	Auto
Start Frequency	1000 MHz
Stop Frequency	10th carrier harmonic
RB / VB (emission in restricted band)	1MHz / 1MHz for Peak

Receiver Parameter	Setting
Attenuation	Auto
Start ~ Stop Frequency	9kHz~150kHz / RB 200Hz for QP
Start ~ Stop Frequency	150kHz~30MHz / RB 9kHz for QP
Start ~ Stop Frequency	30MHz~1000MHz / RB 120kHz for QP

3.4.2 TEST PROCEDURE

- a. The measuring distance of at 3 m shall be used for measurements at frequency up to 1GHz. For frequencies above 1GHz, any suitable measuring distance may be used.
- b. The EUT was placed on the top of a rotating table 0.8 meters above the ground at a 3m meter open area test site. The table was rotated 360 degrees to determine the position of the highest radiation.
- c. The height of the equipment or of the substitution antenna shall be 0.8 m; the height of the test antenna shall vary between 1 m to 4 m.
- d. The initial step in collecting conducted emission data is a spectrum analyzer peak detector mode pre-scanning the measurement frequency range. Significant peaks are then marked and then Quasi Peak detector mode re-measured.
- e. If the Peak Mode measured value compliance with and lower than Quasi Peak Mode Limit, the EUT shall be deemed to meet QP Limits and then no additional QP Mode measurement performed.
- f. For the actual test configuration, please refer to the related Item –EUT Test Photos.

Note:

Both horizontal and vertical antenna polarities were tested and performed pretest to three orthogonal axis. The worst case emissions were reported

During the radiated emission test, the Spectrum Analyzer was set with the following configurations:

Frequency Band (MHz)	Function	Resolution bandwidth	Video Bandwidth
30 to 1000	QP	120 kHz	300 kHz
Above 1000	Peak	1 MHz	1 MHz
	Average	1 MHz	10 Hz

3.4.3 DEVIATION FROM TEST STANDARD

No deviation

3.4.4 TEST SETUP

(A) Radiated Emission Test-Up Frequency Below 30MHz

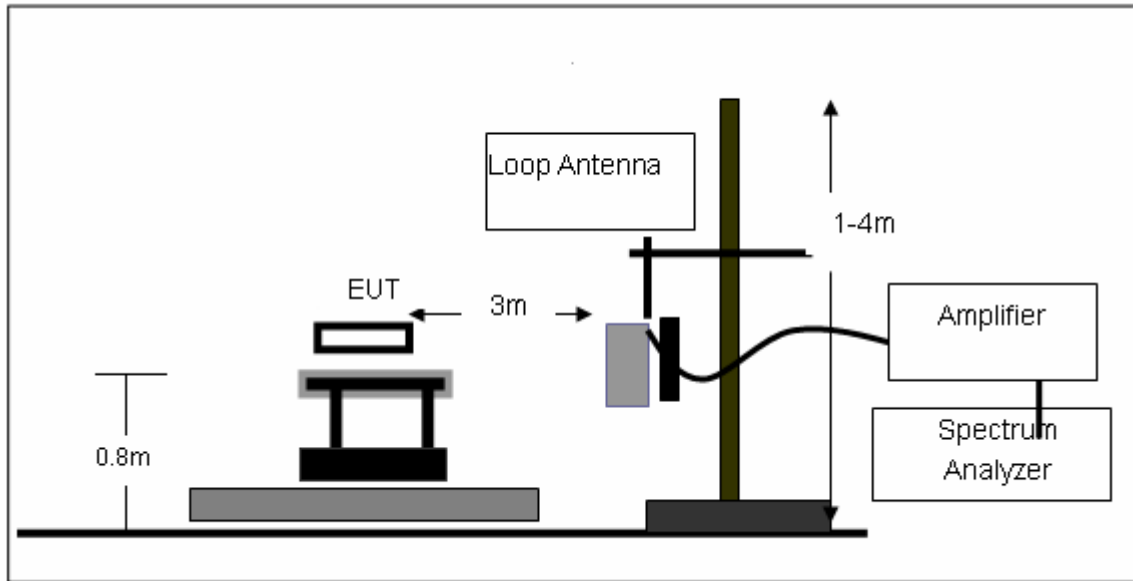

(B) Radiated Emission Test-Up Frequency 30MHz~1GHz

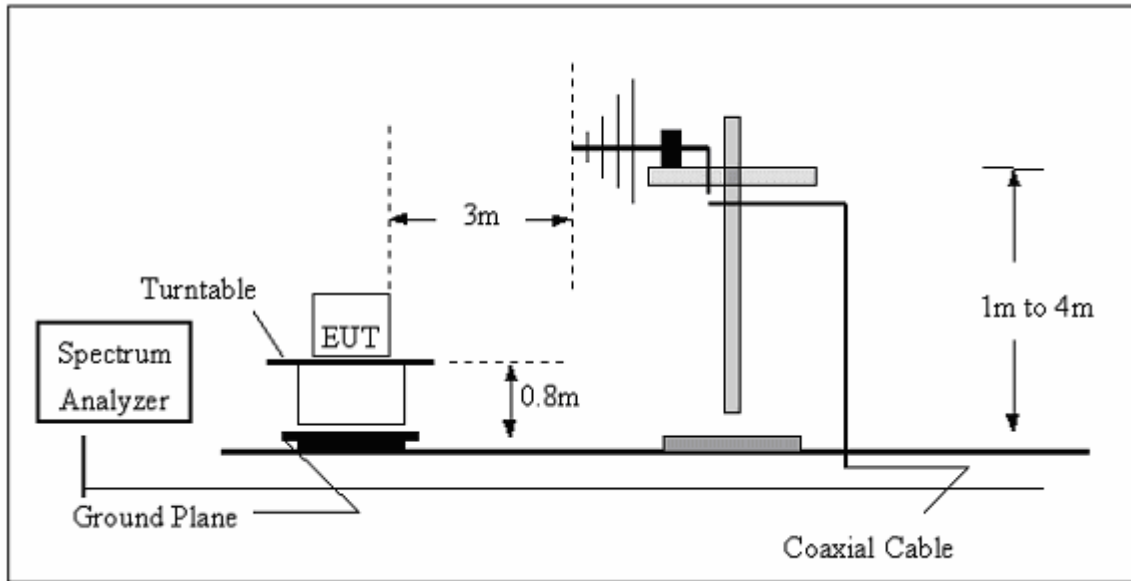

(C) Radiated Emission Test-Up Frequency Above 1GHz

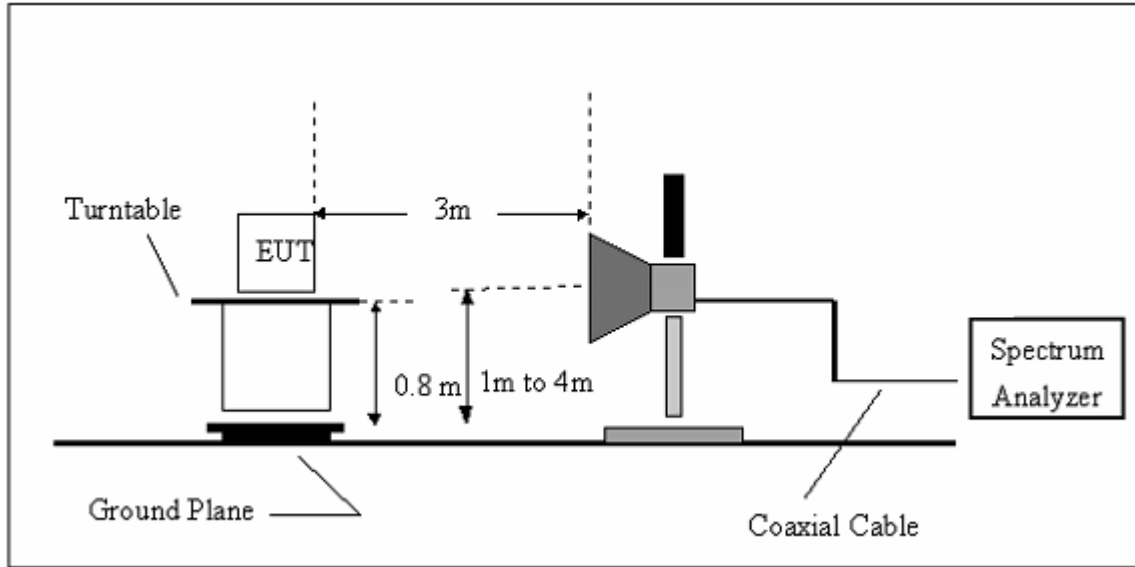

3.4.5 TEST RESULTS (BLOW 30MHz)

EUT :	Dual-model RF & Bluetooth keyboard with touchpad	Model Name. :	KC-KBR101
Temperature :	20 °C	Relative Humidity :	48%
Pressure :	1010 hPa	Test Voltage :	N/A
Test Mode :	TX	Polarization :	--

Freq.	Reading	Limit	Margin	State
(MHz)	(dBuV/m)	(dBuV/m)	(dB)	P/F
--	--	--	--	PASS
--	--	--	--	PASS

NOTE:

The amplitude of spurious emissions which are attenuated by more than 20dB below the permissible value has no need to be reported.

Distance extrapolation factor = $20 \log(\text{specific distance}/\text{test distance})$ (dB);

Limit line = specific limits(dBuv) + distance extrapolation factor.

3.4.6 TEST RESULTS (BETWEEN 30 – 1000 MHZ)

EUT :	Dual-model RF & Bluetooth keyboard with touchpad	Model Name :	KC-KBR101
Temperature :	20 °C	Relative Humidity :	48%
Pressure :	1010 hPa	Test Voltage :	DC 5.0V from adapter AC 120V/60Hz
Test Mode :	TX	Polarization :	Vertical

Frequency (MHz)	Meter Reading (dBμV)	Factor (dB)	Emission Level (dBμV/m)	Limits (dBμV/m)	Margin (dB)	Remark
211.5262	18.24	11.56	29.80	43.50	-13.70	QP
233.3487	16.71	13.04	29.75	46.00	-16.25	QP
425.0280	12.69	18.81	31.50	46.00	-14.50	QP
492.4685	12.55	20.15	32.70	46.00	-13.30	QP
668.1422	14.74	23.91	38.65	46.00	-7.35	QP
986.0715	6.54	27.50	34.04	54.00	-19.96	QP

Remark:

1. Factor = Antenna Factor + Cable Loss – Pre-amplifier.

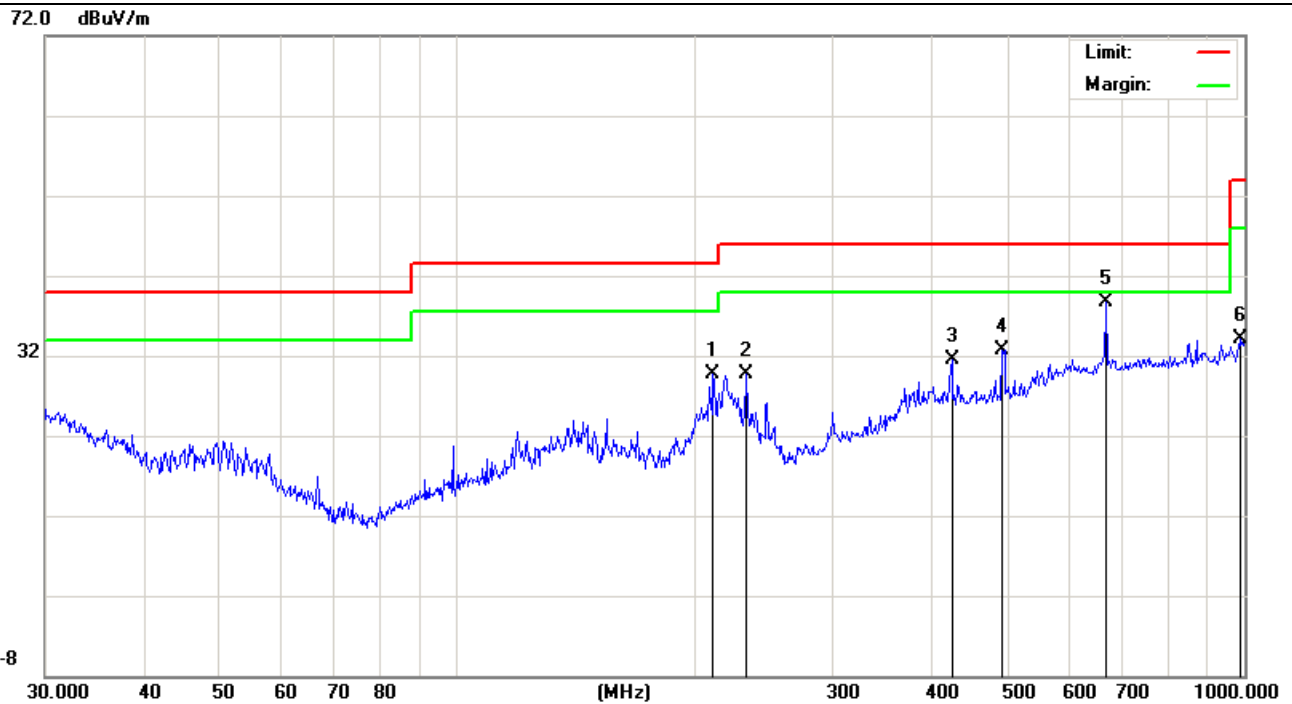

EUT :	Dual-model RF & Bluetooth keyboard with touchpad	Model Name :	KC-KBR101
Temperature :	20 °C	Relative Humidity :	48%
Pressure :	1010 hPa	Test Voltage :	DC 5.0V from adapter AC 120V/60Hz
Test Mode :	TX	Polarization :	Horizontal

Frequency (MHz)	Meter Reading (dBµV)	Factor (dB)	Emission Level (dBµV/m)	Limits (dBµV/m)	Margin (dB)	Remark
162.0414	16.08	10.50	26.58	43.50	-16.92	QP
212.2692	22.80	11.61	34.41	43.50	-9.09	QP
319.9370	18.57	14.98	33.55	46.00	-12.45	QP
423.5403	18.75	18.78	37.53	46.00	-8.47	QP
665.8034	13.98	23.85	37.83	46.00	-8.17	QP
972.3374	6.74	27.43	34.17	54.00	-19.83	QP

Remark:

- Factor = Antenna Factor + Cable Loss – Pre-amplifier.

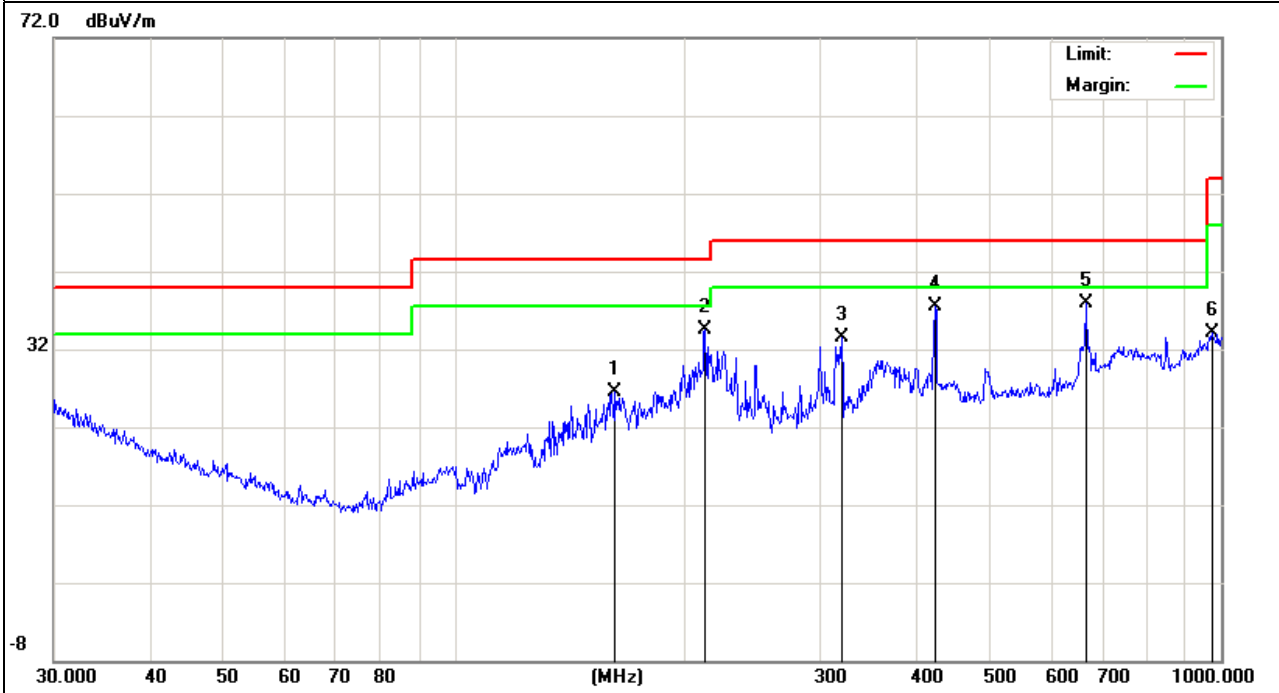

3.4.7 TEST RESULTS (ABOVE 1000 MHZ)

EUT :	Dual-model RF & Bluetooth keyboard with touchpad	Model Name :	KC-KBR101
Temperature :	20 °C	Relative Humidity :	48%
Pressure :	1010 hPa	Test Voltage :	DC 5.0V from adapter AC 120V/60Hz
Test Mode :	TX-2401MHZ	Polarization :	Horizontal

Frequency (MHz)	Meter Reading (dBμV)	Factor (dB)	Emission Level (dBμV/m)	Limits (dBμV/m)	Margin (dB)	Detector Type
2401.216	92.89	-12.99	79.90	114.00	-34.10	peak
2401.216	85.33	-12.99	72.34	94.00	-21.66	AVG
4802.245	62.56	-3.65	58.91	74.00	-15.09	peak
4802.245	52.24	-3.65	48.59	54.00	-5.41	AVG

Remark:
Factor = Antenna Factor + Cable Loss – Pre-amplifier.

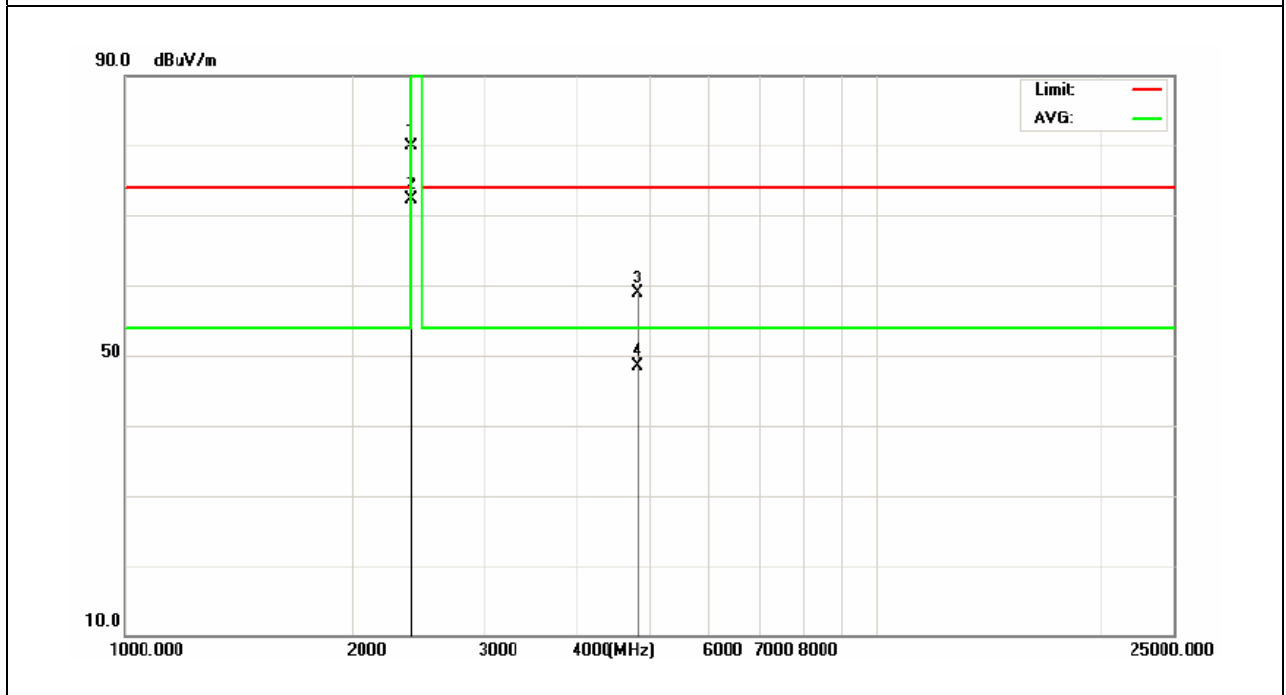

EUT :	Dual-model RF & Bluetooth keyboard with touchpad	Model Name :	KC-KBR101
Temperature :	20 °C	Relative Humidity :	48%
Pressure :	1010 hPa	Test Voltage :	DC 5.0V from adapter AC 120V/60Hz
Test Mode :	TX-2401MHz	Polarization :	Vertical

Frequency (MHz)	Meter Reading (dBµV)	Factor (dB)	Emission Level (dBµV/m)	Limits (dBµV/m)	Margin (dB)	Detector Type
2401.235	93.09	-12.99	80.10	114.00	-33.90	peak
2401.235	85.14	-12.99	72.15	94.00	-21.85	AVG
4802.512	61	-3.65	57.35	74.00	-16.65	peak
4802.512	51.82	-3.65	48.17	54.00	-5.83	AVG

Remark:
 Factor = Antenna Factor + Cable Loss – Pre-amplifier.

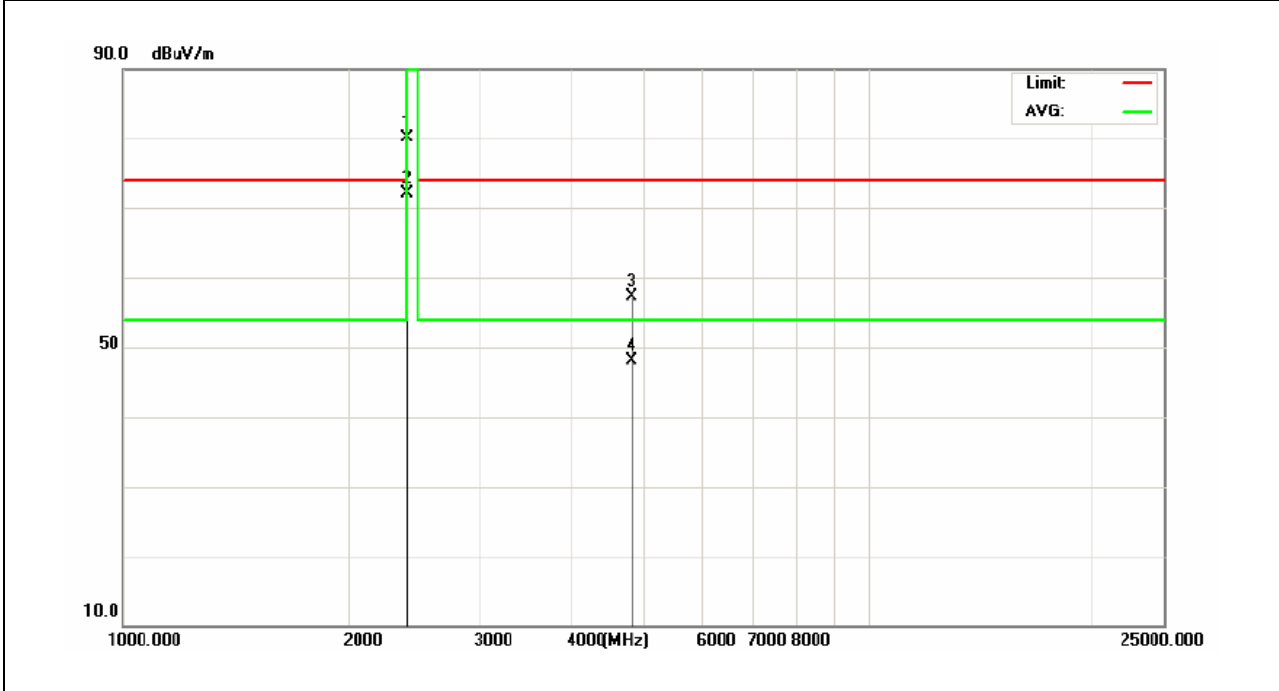

EUT :	Dual-model RF & Bluetooth keyboard with touchpad	Model Name :	KC-KBR101
Temperature :	20 °C	Relative Humidity :	48%
Pressure :	1010 hPa	Test Voltage :	DC 5.0V from adapter AC 120V/60Hz
Test Mode :	TX-2440MHz	Polarization :	Horizontal

Frequency (MHz)	Meter Reading (dBµV)	Factor (dB)	Emission Level (dBµV/m)	Limits (dBµV/m)	Margin (dB)	Detector Type
2440.321	93.34	-12.94	80.40	114.00	-33.60	peak
2440.321	86.58	-12.94	73.64	94.00	-20.36	AVG
4880.069	61.47	-3.67	57.80	74.00	-16.20	peak
4880.069	51.96	-3.67	48.29	54.00	-5.71	AVG

Remark:
Factor = Antenna Factor + Cable Loss – Pre-amplifier.

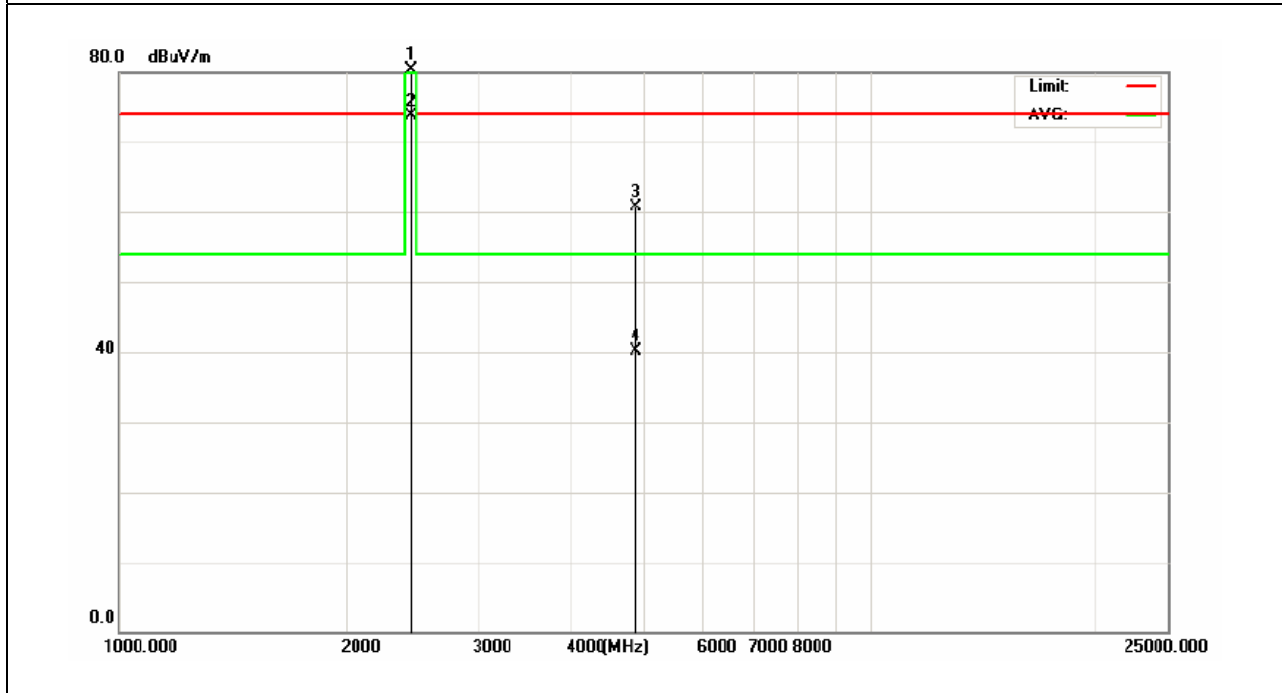

EUT :	Dual-model RF & Bluetooth keyboard with touchpad	Model Name :	KC-KBR101
Temperature :	20 °C	Relative Humidity :	48%
Pressure :	1010 hPa	Test Voltage :	DC 5.0V from adapter AC 120V/60Hz
Test Mode :	TX-2440MHz	Polarization :	Vertical

Frequency (MHz)	Meter Reading (dBµV)	Factor (dB)	Emission Level (dBµV/m)	Limits (dBµV/m)	Margin (dB)	Detector Type
2440.159	94.04	-12.94	81.10	114.00	-32.90	peak
2440.159	84.33	-12.94	71.39	94.00	-22.61	AVG
4880.228	61.27	-3.67	57.60	74.00	-16.40	peak
4880.228	53.33	-3.67	49.66	54.00	-4.34	AVG

Remark:
Factor = Antenna Factor + Cable Loss – Pre-amplifier.

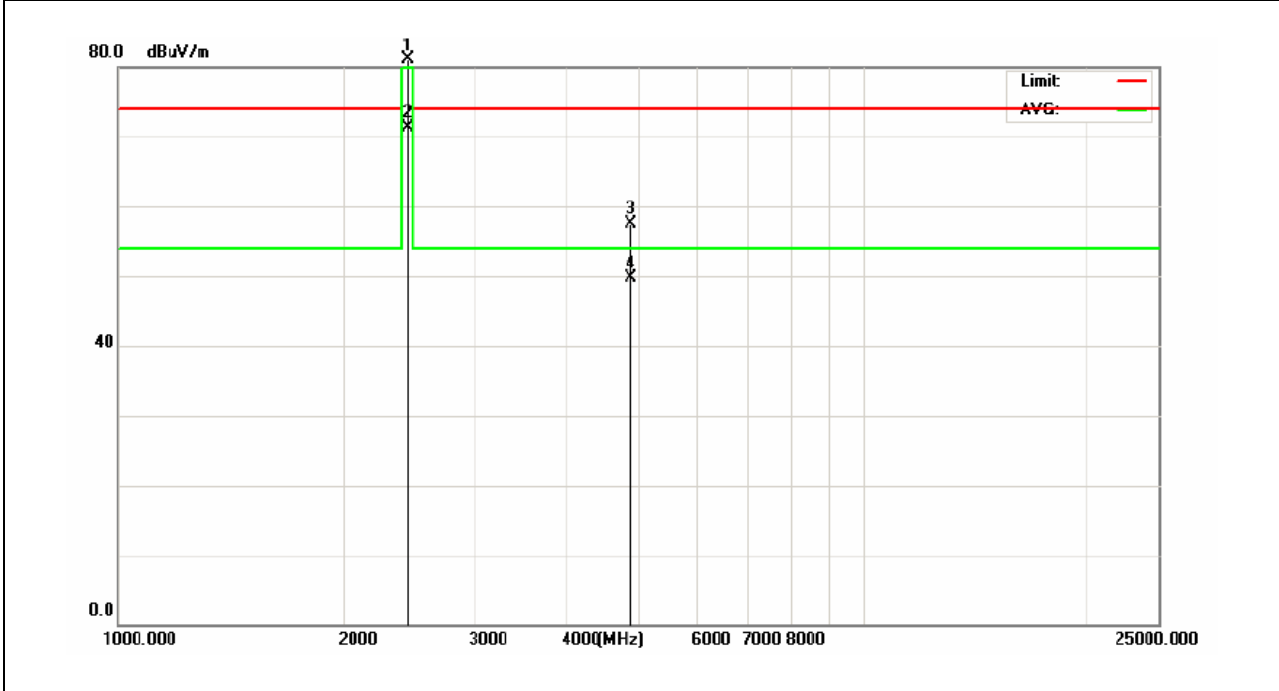

EUT :	Dual-model RF & Bluetooth keyboard with touchpad	Model Name :	KC-KBR101
Temperature :	20 °C	Relative Humidity :	48%
Pressure :	1010 hPa	Test Voltage :	DC 5.0V from adapter AC 120V/60Hz
Test Mode :	TX-2480MHz	Polarization :	Horizontal

Frequency (MHz)	Meter Reading (dBμV)	Factor (dB)	Emission Level (dBμV/m)	Limits (dBμV/m)	Margin (dB)	Detector Type
2480.251	93.99	-12.79	81.20	114.00	-32.80	peak
2480.251	84.52	-12.79	71.73	94.00	-22.27	AVG
4960.185	60.19	-3.59	56.60	74.00	-17.40	peak
4960.185	52.33	-3.59	48.74	54.00	-5.26	AVG

Remark:
Factor = Antenna Factor + Cable Loss – Pre-amplifier.

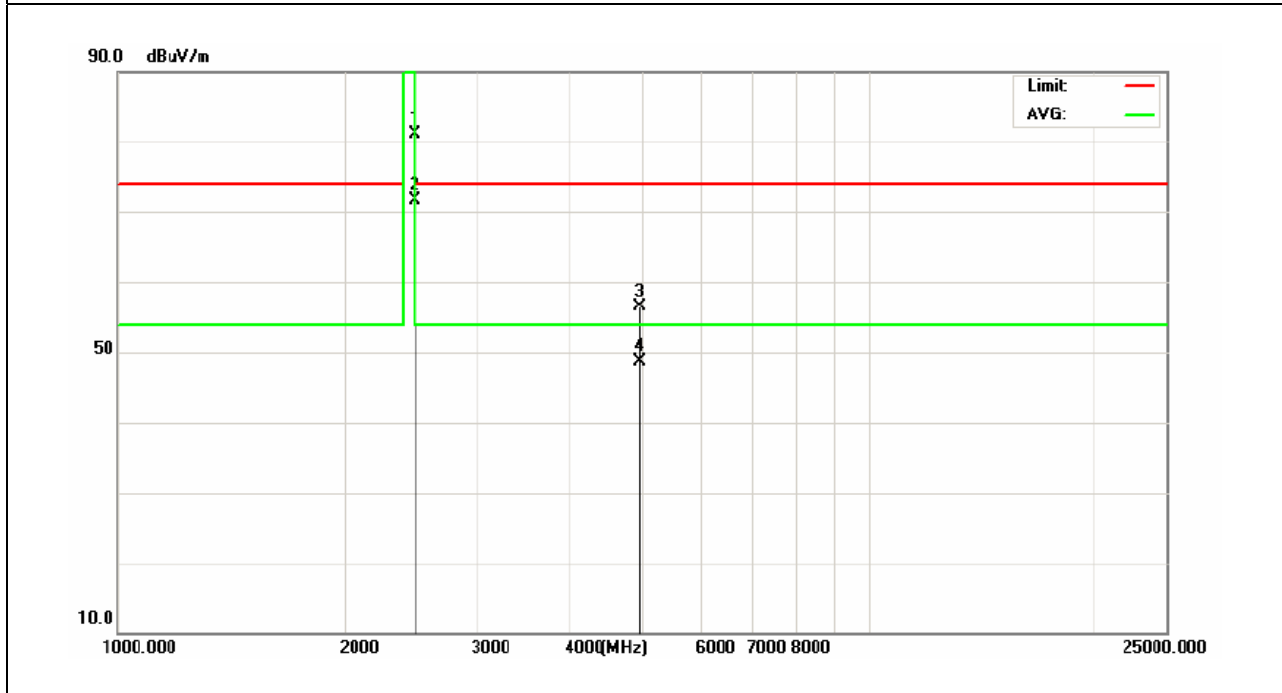

EUT :	Dual-model RF & Bluetooth keyboard with touchpad	Model Name :	KC-KBR101
Temperature :	20 °C	Relative Humidity :	48%
Pressure :	1010 hPa	Test Voltage :	DC 5.0V from adapter AC 120V/60Hz
Test Mode :	TX-2480MHz	Polarization :	Vertical

Frequency (MHz)	Meter Reading (dBµV)	Factor (dB)	Emission Level (dBµV/m)	Limits (dBµV/m)	Margin (dB)	Detector Type
2480.037	94.79	-12.79	82.00	114.00	-32.00	2480.037
2480.037	84.96	-12.79	72.17	94.00	-21.83	2480.037
4960.311	62.49	-3.59	58.90	74.00	-15.10	4960.311
4960.311	52.79	-3.59	49.20	54.00	-4.80	4960.311

Remark:
Factor = Antenna Factor + Cable Loss – Pre-amplifier.

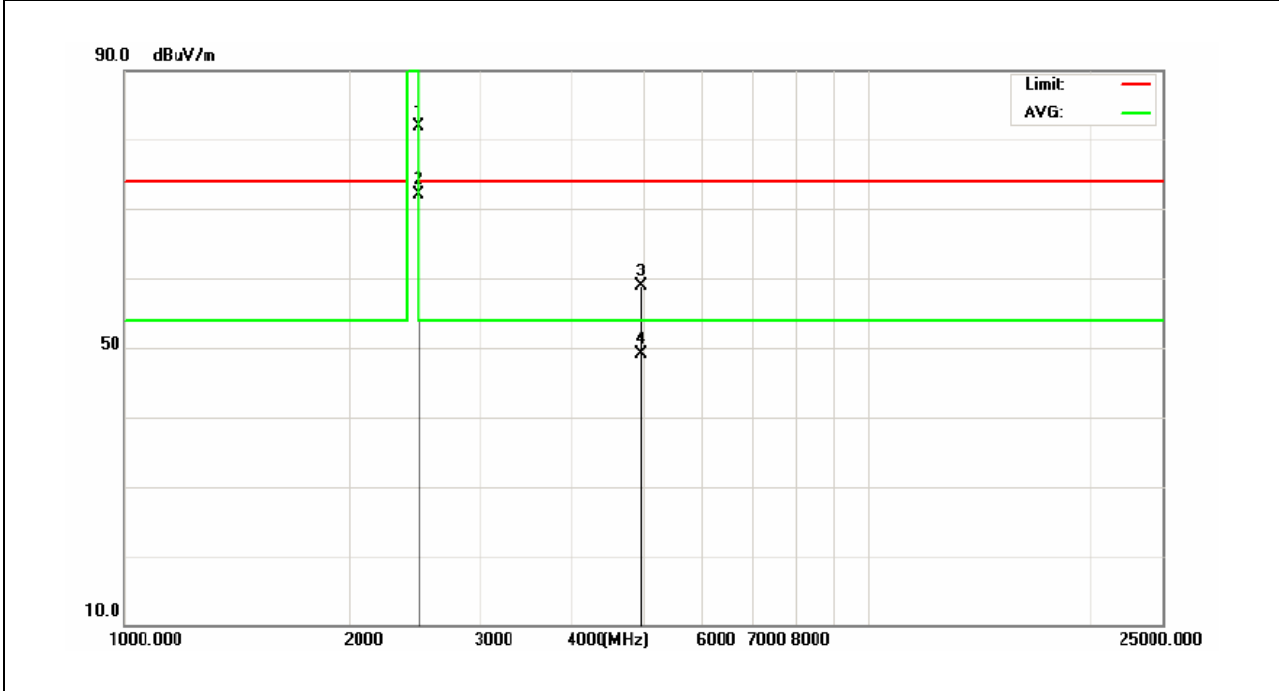

3.4.8 TEST RESULTS (RESTRICTED BANDS REQUIREMENTS)

EUT :	Dual-model RF & Bluetooth keyboard with touchpad	Model Name :	KC-KBR101
Temperature :	20 °C	Relative Humidity :	48%
Pressure :	1010 hPa	Test Voltage :	DC 5.0V from adapter AC 120V/60Hz
Test Mode :	TX-2401MHz	Polarization :	Horizontal

Frequency (MHz)	Meter Reading (dBμV)	Factor (dB)	Emission Level (dBμV/m)	Limits (dBμV/m)	Margin (dB)	Detector Type
2326.39	46.97	-13.07	33.90	74.00	-40.10	peak
2400.00	51.39	-12.99	38.40	74.00	-35.60	peak

Remark:
Factor = Antenna Factor + Cable Loss – Pre-amplifier.

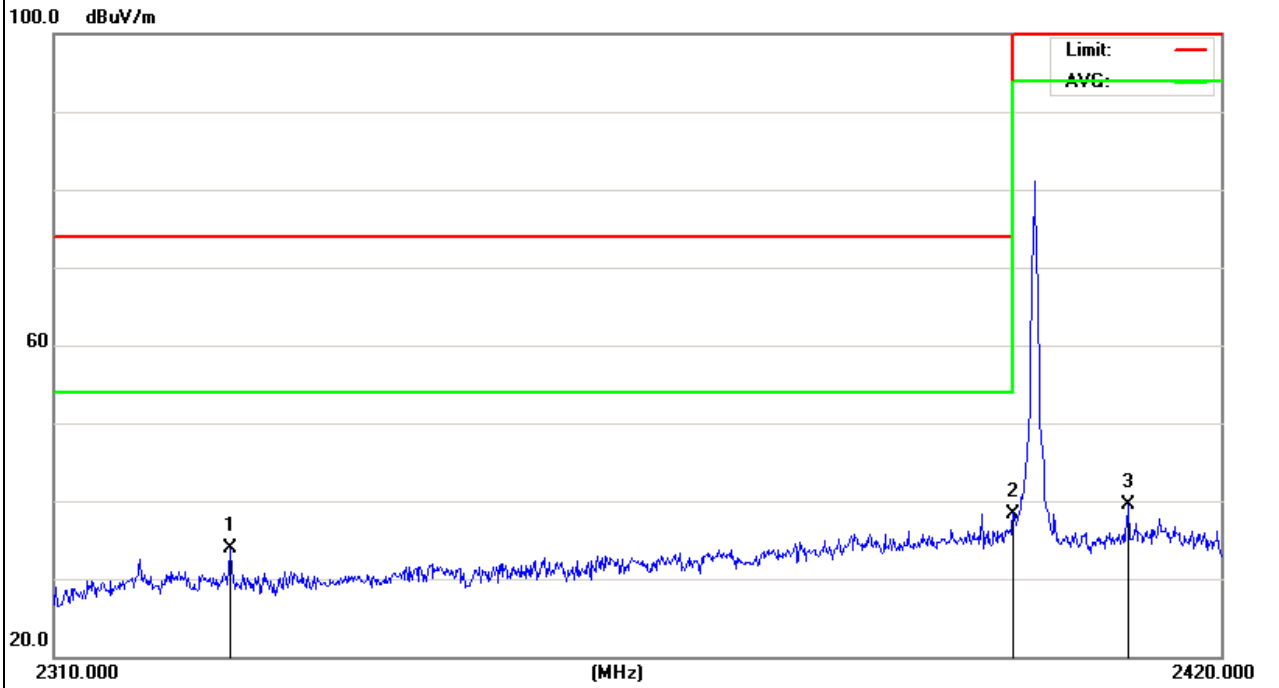

EUT :	Dual-model RF & Bluetooth keyboard with touchpad	Model Name :	KC-KBR101
Temperature :	20 °C	Relative Humidity :	48%
Pressure :	1010 hPa	Test Voltage :	DC 5.0V from adapter AC 120V/60Hz
Test Mode :	TX-2401MHz	Polarization :	Vertical

Frequency (MHz)	Meter Reading (dBμV)	Factor (dB)	Emission Level (dBμV/m)	Limits (dBμV/m)	Margin (dB)	Detector Type
2326.170	51.72	-13.07	38.65	74.00	-35.35	peak
2390.080	54.52	-13.06	41.46	74.00	-32.54	peak
2400.000	53.81	-12.99	38.82	74.00	-35.18	peak

Remark:
Factor = Antenna Factor + Cable Loss – Pre-amplifier.

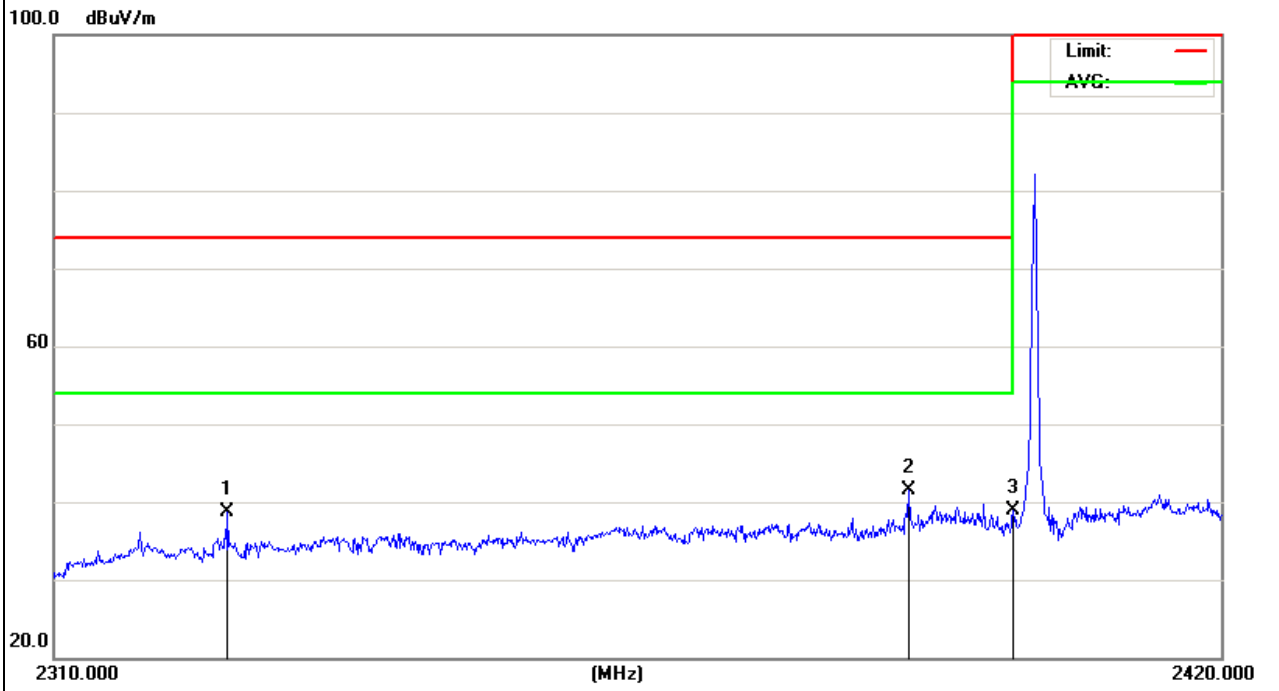

EUT :	Dual-model RF & Bluetooth keyboard with touchpad	Model Name :	KC-KBR101
Temperature :	20 °C	Relative Humidity :	48%
Pressure :	1010 hPa	Test Voltage :	DC 5.0V from adapter AC 120V/60Hz
Test Mode :	TX-2480MHz	Polarization :	Horizontal

Frequency (MHz)	Meter Reading (dBµV)	Factor (dB)	Emission Level (dBµV/m)	Limits (dBµV/m)	Margin (dB)	Detector Type
2483.500	49.46	-12.78	36.68	74.00	-37.32	peak
2491.950	48.09	-12.76	35.33	74.00	-38.67	peak

Remark:
 Factor = Antenna Factor + Cable Loss – Pre-amplifier.

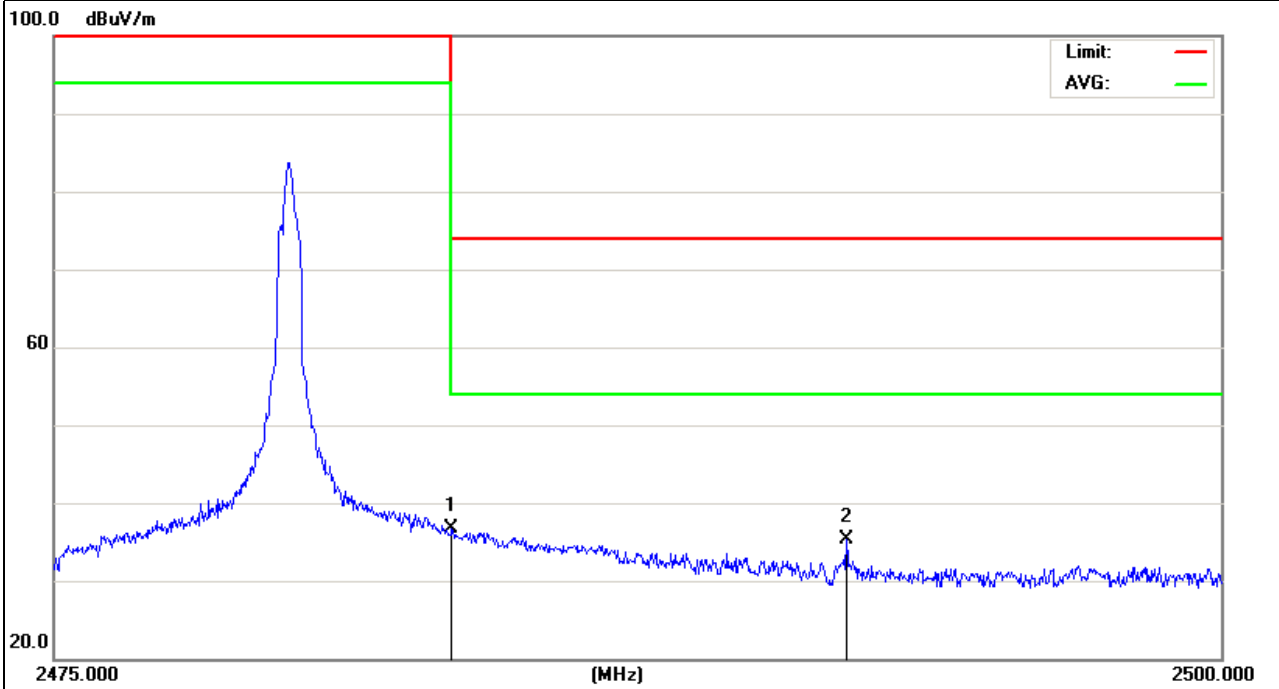

EUT :	Dual-model RF & Bluetooth keyboard with touchpad	Model Name :	KC-KBR101
Temperature :	20 °C	Relative Humidity :	48%
Pressure :	1010 hPa	Test Voltage :	DC 5.0V from adapter AC 120V/60Hz
Test Mode :	TX-2480MHz	Polarization :	Vertical

Frequency (MHz)	Meter Reading (dBµV)	Factor (dB)	Emission Level (dBµV/m)	Limits (dBµV/m)	Margin (dB)	Detector Type
2483.500	49.26	-12.78	36.48	74.00	-37.52	peak
2484.825	53.67	-12.78	40.89	74.00	-33.11	peak

Remark:
 Factor = Antenna Factor + Cable Loss – Pre-amplifier.

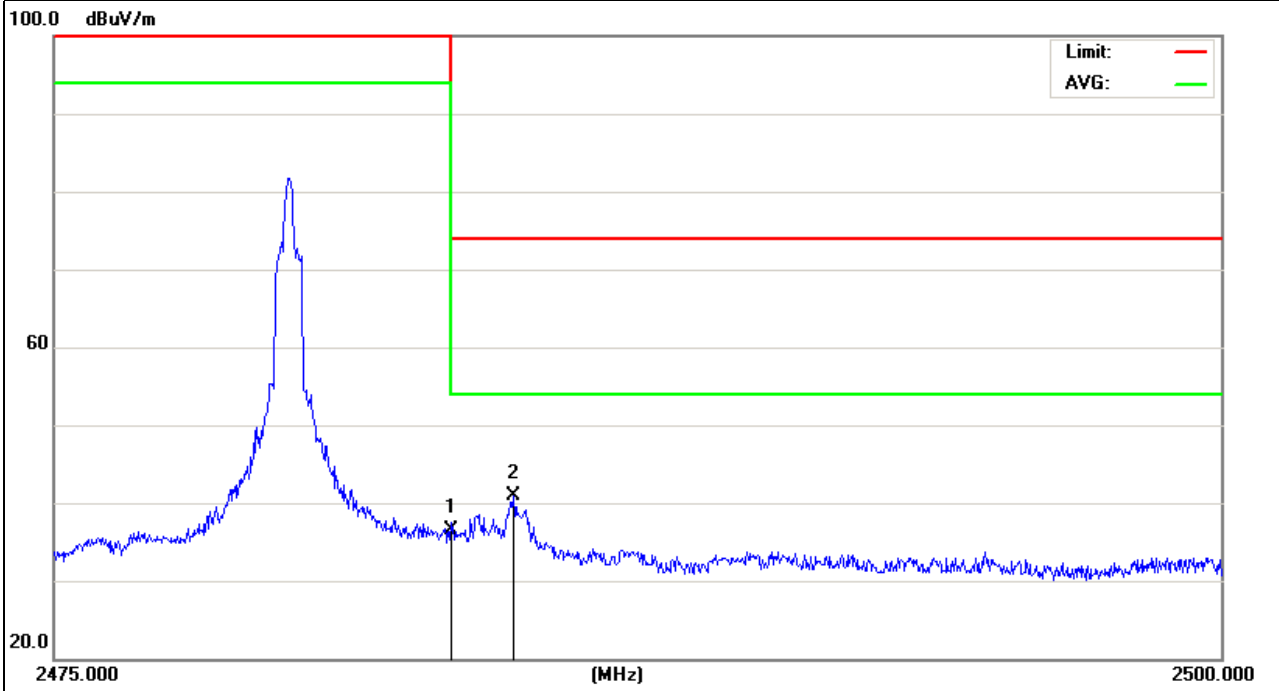

4. BANDWIDTH TEST

4.1 TEST PROCEDURE

- a. The EUT was directly connected to the spectrum analyzer and antenna output port as show in the block diagram below,
- b. Spectrum Setting : RBW= 100KHz, VBW \geq RBW, Sweep time = Auto.

4.2 DEVIATION FROM STANDARD

No deviation.

4.3 TEST SETUP



4.4 TEST RESULTS

EUT :	Dual-model RF & Bluetooth keyboard with touchpad	Model Name :	KC-KBR101
Temperature :	26 °C	Relative Humidity :	53%
Pressure :	1020 hPa	Test Power :	DC 5.0V from adapter AC 120V/60Hz
Test Mode :	TX		

Frequency (MHz)	20 dBc Bandwidth (MHz)	99% Bandwidth (MHz)
2401	0.5719	0.5968
2440	0.6609	0.6391
2480	0.7221	0.7252

The Lowest Channel:2401MHz

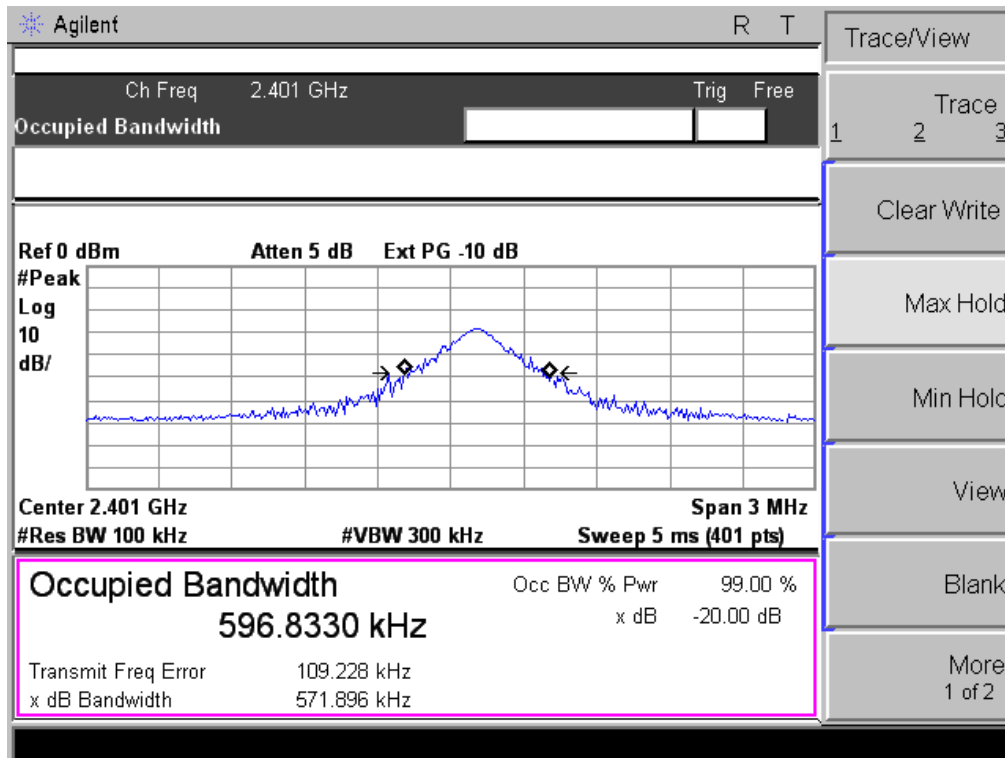

The Middle Channel: 2440MHz

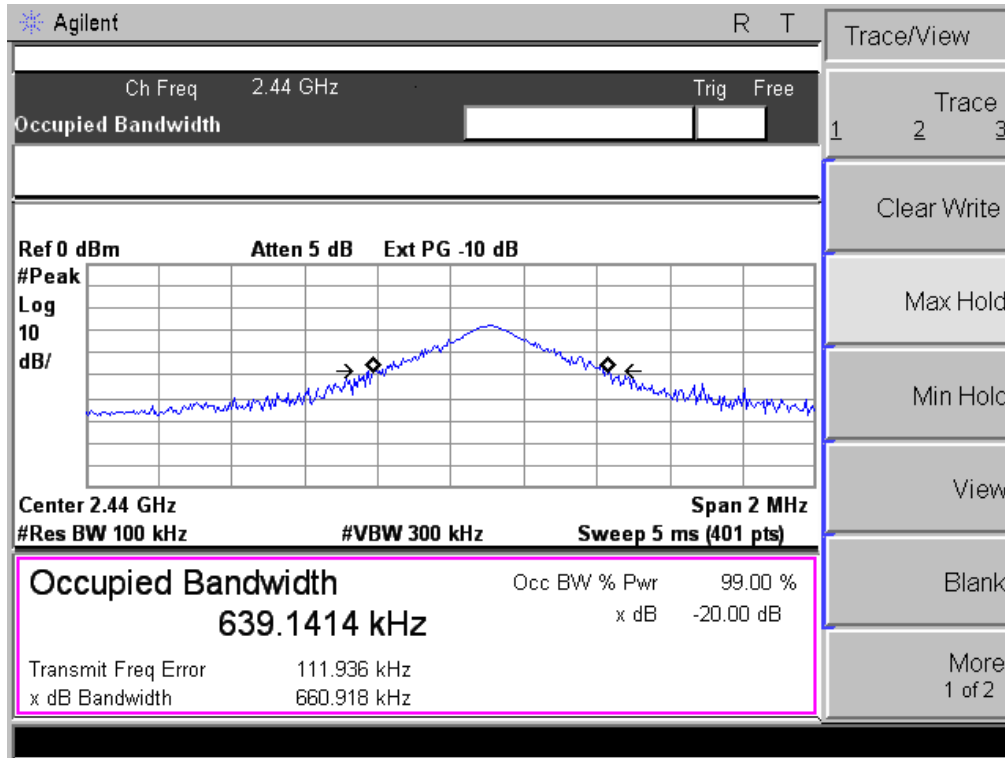

The HIGH Channel: 2480MHz

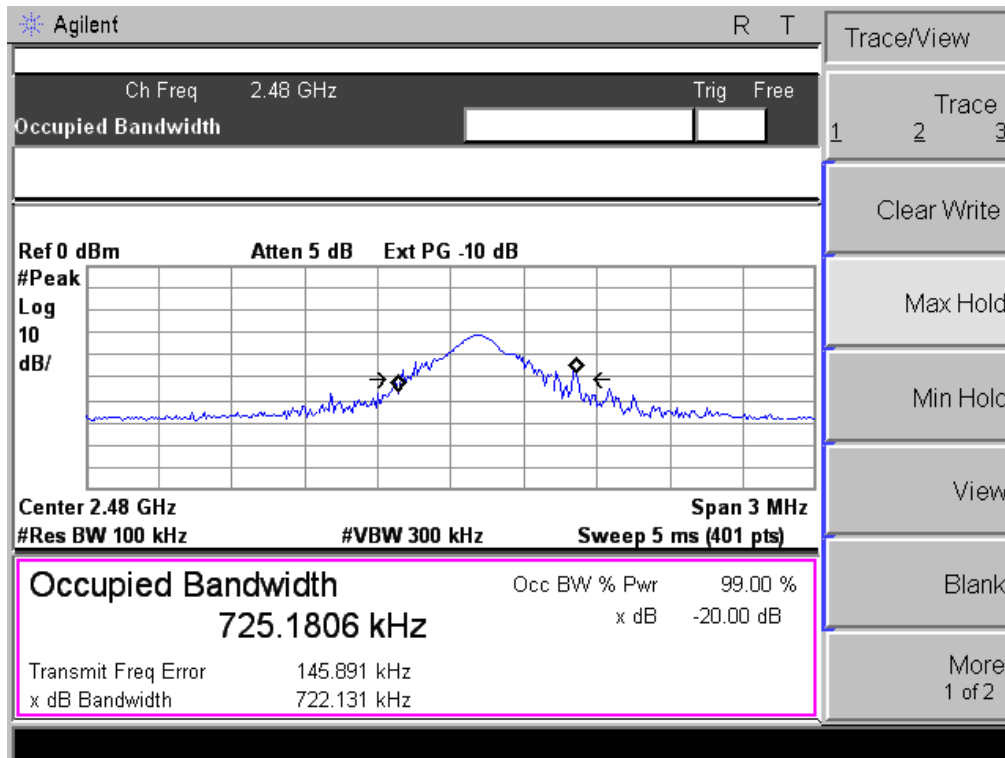

5. EUT TEST PHOTO

Radiated Measurement Photos

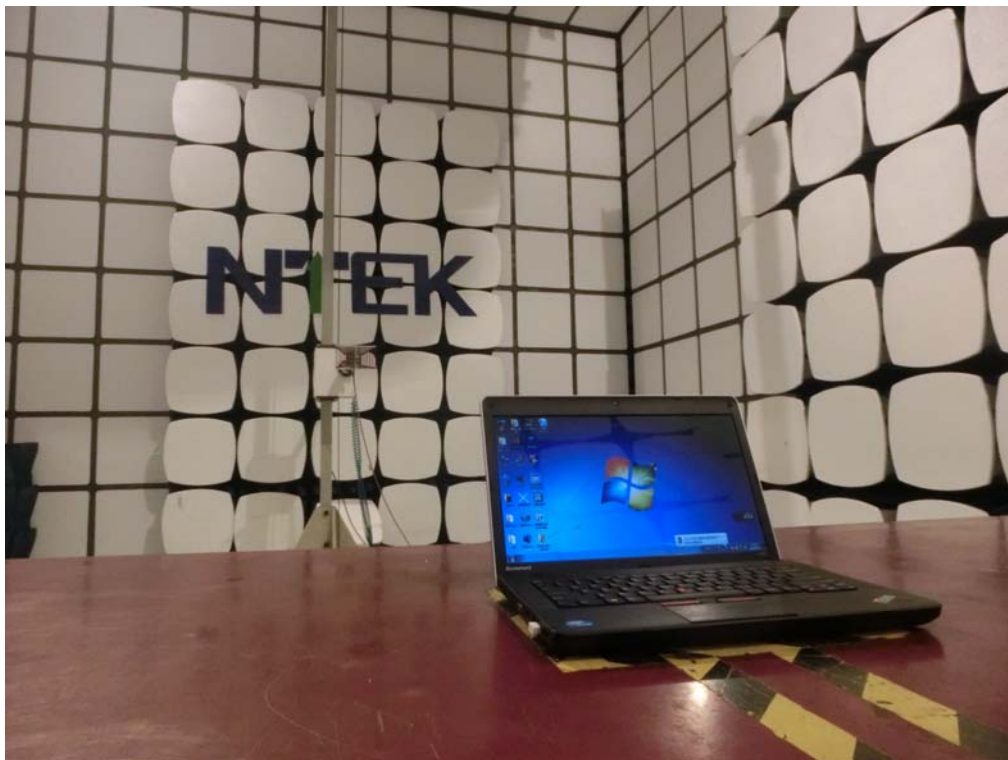

CONDUCTED EMISSION Photos

