

FCC PART 95 TEST REPORT

Report Reference No......: **TZ170100273-GMRS/FRS**

FCC ID.....: **2ACVFT-228**

Compiled by

(position+printed name+signature)..: File administrators Tony Li

Supervised by

(position+printed name+signature)..: Technique principal Robin Fang

Approved by

(position+printed name+signature)..: Manager James Wu

Tony Li
Robin Fang
James Wu

Date of issue.....: May 2, 2017

Representative Laboratory Name: Shenzhen Tongzhou Testing Co.,Ltd

Address: 1th floor, building 1, Haomai High-tech park, Huating Road 387, Dalang street, Longhua, Shenzhen, China

Testing Laboratory Name: Dongguan Dongdian Testing Service Co.,Ltd

Address: No.17, Zongbu Road 2, Songshan Lake Sci&Tech, Industry Park, Dongguan City, Guangdong Province, China

Applicant's name: **Shenzhen ChangTaiWei Electronic CO.,LTD**

Address: 5/F.,6 Block, XinGu Industrial zone, GuShu Village,XiXiang Town,BaoAn District,Shenzhen City,GuangDong Province,China

Test specification

Standard: **47 CFR § 95 Personal Radio Service**
ANSI/TIA 603-D:2010

TRF Originator: Shenzhen Tongzhou Testing Co.,Ltd

Master TRF.....: Dated 2016-01

Shenzhen Tongzhou Testing Co.,Ltd All rights reserved.

This publication may be reproduced in whole or in part for non-commercial purposes as long as the Shenzhen Tongzhou Testing Co.,Ltd is acknowledged as copyright owner and source of the material. Shenzhen Tongzhou Testing Co.,Ltd takes no responsibility for and will not assume liability for damages resulting from the reader's interpretation of the reproduced material due to its placement and context.

Test item description: Two Way Radio

Trade Mark: Victoria

Model/Type reference.....: T-228

Listed Models: /

Manufacturer: **Shenzhen ChangTaiWei Electronic CO.,LTD**

Type of Emission: FM

Rating: DC 4.5V By battery

Result.....: **PASS**

TEST REPORT

Test Report No. :	TZ170100273-GMRS/FRS	May 2, 2017
		Date of issue

Equipment under Test : Two Way Radio

Model /Type : T-228

Listed Models : /

Applicant : **Shenzhen ChangTaiWei Electronic CO.,LTD**

Address : 5/F.,6 Block, XinGu Industrial zone, GuShu Village,XiXiang Town,BaoAn District,Shenzhen City,GuangDong Province,China

Manufacturer : **Shenzhen ChangTaiWei Electronic CO.,LTD**

Address : 5/F.,6 Block, XinGu Industrial zone, GuShu Village,XiXiang Town,BaoAn District,Shenzhen City,GuangDong Province,China

Test Result:	PASS
---------------------	-------------

The test report merely corresponds to the test sample.

It is not permitted to copy extracts of these test result without the written permission of the test laboratory.

**** Modified History ****

Revision	Description	Issued Data	Remark
Revision 1.0	Initial Test Report Release	2017-05-02	Andy Zhang

Contents

<u>1.</u>	<u>TEST STANDARDS</u>	<u>5</u>
<u>2.</u>	<u>SUMMARY</u>	<u>6</u>
2.1.	General Remarks	6
2.2.	Product Description	6
2.3.	Equipment Under Test	6
2.4.	EUT operation mode	6
2.5.	Block Diagram of Test Setup	7
2.6.	Related Submittal(s) / Grant (s)	7
2.7.	Modifications	7
2.8.	Additional Comments	7
<u>3.</u>	<u>TEST ENVIRONMENT</u>	<u>10</u>
3.1.	Address of the test laboratory	10
3.2.	Test Facility	10
3.3.	Environmental conditions	10
3.4.	Test Description	10
3.5.	Statement of the measurement uncertainty	11
3.6.	Equipments Used during the Test	11
<u>4.</u>	<u>TEST CONDITIONS AND RESULTS.....</u>	<u>12</u>
4.1.	RF POWER OUTPUT	12
4.2.	Modulation Characteristics	15
4.3.	Occupied Bandwidth and Emission Mask	22
4.4.	Field Strength Spurious Emissions	27
4.5.	Frequency Stability	30

1. TEST STANDARDS

The tests were performed according to following standards:

[FCC Rules Part 95: 2016](#) Personal Radio Services

[FCC part 95 Subpart A: 2016](#) General Mobile Radio Service (GMRS)

[FCC part 95 Subpart B: 2016](#) Family Radio Service (FRS)

[TIA/EIA 603 D: June 2010](#) Land Mobile FM or PM Communications Equipment Measurement and Performance Standards.

[FCC Part 2: 2016](#) Frequency allocations and radio treaty matters, general rules and regulations.

2. SUMMARY

2.1. General Remarks

Date of receipt of test sample	:	April 18, 2017
Testing commenced on	:	April 18, 2017
Testing concluded on	:	May 2, 2017

2.2. Product Description

The **Shenzhen ChangTaiWei Electronic CO.,LTD**'s Model: T-228 or the "EUT" as referred to in this report; more general information as follows, for more details, refer to the user's manual of the EUT.

Name of EUT	Two Way Radio
Model/Type reference	T-228
Listed Models	/
FCC ID	2ACVFT-228
Modulation Type	FM for Analog Voice
Emission Designator	11K0F3E
Maximum Output Power	0.5W ERP for FRS/GMRS
Antenna Type	External and Ingrate (cannot removed)
Frequency Range	GMRS: 462.55MHz-462.7250MHz FRS: 467.5625MHz-467.7125MHz

2.3. Equipment Under Test

Power supply system utilised

Power supply voltage	:	<input type="radio"/> 120V / 60 Hz	<input type="radio"/> 115V / 60Hz
		<input type="radio"/> 12 V DC	<input type="radio"/> 24 V DC
		<input checked="" type="radio"/> Other (specified in blank below)	

DC 4.5V By battery

2.4. EUT operation mode

EUT operation mode no.	Description of operation mode	Additional information
Op 1	FM+BW12.5KHz+GMRS+TX	The equipment is set with FM modulation and 12.5KHz bandwidth at GMRS mode for transmitter, powered by DC 4.50V
Op 2	FM+BW12.5KHz+FRS+TX	The equipment is set with FM modulation and 12.5KHz bandwidth at FRS mode for transmitter, powered by DC 4.50V
Op 3	Standby	Standby Mode, powered by DC 4.50V
Note:		
1. The sample will states RX and standby at same time according to half duplex work principle.		

2.5. Block Diagram of Test Setup

Fig. 2-1 Configuration of Tested System

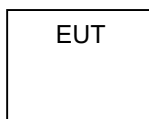

2.6. Related Submittal(s) / Grant (s)

This submittal(s) (test report) is intended for **FCC ID: 2ACVFT-228** filing to comply with FCC Part 2, FCC Part 95A and Part 95B of the FCC CFR 47 Rules.

2.7. Modifications

No modifications were implemented to meet testing criteria.

2.8. Additional Comments

GMRS transmitter channel frequencies

According to §95.621: The GMRS transmitter channel frequencies (reference frequencies from which the carrier frequency, suppressed or otherwise, may not deviate by more than the specified frequency tolerance) are 462.5500, 462.5625, 462.5750, 462.5875, 462.6000, 462.6125, 462.6250, 462.6375, 462.6500, 462.6625, 462.6750, 462.6875, 462.7000, 462.7125, 462.7250, 467.5500, 467.5750, 467.6000, 467.6250, 467.6500, 467.6750, 467.7000, and 467.7250.

M-880 woks 15 frequencies at GMRS mode within §95.621 require frequencies; frequencies list as follows

Channel	Frequency (MHz)	Mode type
1	462.5625	GMRS
2	462.5875	GMRS
3	462.6125	GMRS
4	462.6375	GMRS
5	462.6625	GMRS
6	462.6875	GMRS
7	462.7125	GMRS
15	462.5500	GMRS
16	462.5750	GMRS
17	462.6000	GMRS
18	462.6250	GMRS
19	462.6500	GMRS
20	462.6750	GMRS
21	462.7000	GMRS
22	462.7250	GMRS

FRS transmitter channel frequencies

According to §95.626: the FRS unit channel frequencies are:

Channel No.	(MHz)
1	462.5625
2	462.5875
3	462.6125
4	462.6375
5	462.6625
6	462.6875
7	462.7125
8	467.5625

9	467.5875
10	467.6125
11	467.6375
12	467.6625
13	467.6875
14	467.7125

M-880 works 7 frequencies at FRS mode within §95.626 require frequencies; frequencies list as follows

Channel	Frequency (MHz)	Mode type
8	467.5625	FRS
9	467.5875	FRS
10	467.6125	FRS
11	467.6375	FRS
12	467.6625	FRS
13	467.6875	FRS
14	467.7125	FRS

Emission types requirement for FCC Part 95 devices

According to §95.631 Emission types should meet;

- (a) A GMRS transmitter must transmit only emission types A1D, F1D, G1D, H1D, J1D, R1D, A3E, F3E, G3E, H3E, J3E or R3E. A non-voice emission is limited to selective calling or tone-operated squelch tones to establish or continue voice communications. See §95.181 (g) and (h).
- (b) An R/C transmitter may transmit any appropriate non-voice emission which meets the emission limitations of §95.633.
- (c) A CB transmitter may transmit only emission types A1D, H1D, J1D, R1D, A3E, H3E, J3E, R3E. A non-voice emission is limited to selective calling or tone-operated squelch tones to establish or continue voice communications. See §95.412 (b) and (c).
- (d) An FRS unit may transmit only emission type F3E or F2D. A non-voice emission is limited to selective calling or tone-operated squelch tones to establish or continue voice communications, digital data transmission of location information or text messaging.
- (e) No GMRS or CB transmitter shall employ a digital modulation or emission.
- (f) No GMRS, CB or R/C transmitter shall transmit non-voice data.
- (g) An LPRS station may transmit any emission type appropriate for communications in this service. Two-way voice communications, however, are prohibited.
- (h) A MedRadio station may transmit any emission type appropriate for communications in this service. Voice communications, however, are prohibited.
- (i) A WMTS station may transmit any emission type appropriate for communications in this service, except for video and voice. Waveforms such as electrocardiograms (ECGs) are not considered video.
- (j) A MURS transmitter must transmit only emission types A1D, A2B, A2D, A3E, F2B, F1D, F2D, F3E, G3E. Emission types A3E, F3E and G3E include selective calling or tone-operated squelch tones to establish or continue voice communications. MURS transmitters are prohibited from transmitting in the continuous carrier mode.
- (k) DSRCS-OBUs are governed under subpart L of this part.

M-880 works at FM voice (F3E) for GMRS and FRS;

FCC rules for FCC Part 95 test frequency requirements

According to FCC rules: Except where otherwise specified, measurements shall be performed for each frequency band of operation for which the radio apparatus is to be certified, with the device operating at the frequencies in each band of operation shown in Table below. The frequencies selected for measurements shall be reported in the test report.

Table Frequency Range of Operation

Frequency Range Over Which the Device Operates (in each Band)	Number of Measurement Frequencies Required	Location of Measurement Frequency in Band of Operation
1 MHz or less	1	middle
1 MHz to 10 MHz	2	1 near high end, 1 near low end
Greater than 10 MHz	3	1 near high end, 1 near middle, 1 near low end

The application will programmable channels and power by software (not open to end-user, only open to agency), test labs can only tune knob to change channels;

The application provide test channels as follows;

Modulation	Channel separation	Channel number	Frequency (MHz)
GMRS/FM	12.5 KHz	Ch4	462.6375
FRS/FM	12.5 KHz	Ch11	467.6375

3. TEST ENVIRONMENT

3.1. Address of the test laboratory

Dongguan Dongdian Testing Service Co.,Ltd

No.17, Zongbu Road 2, Songshan Lake Sci&Tech, Industry Park, Dongguan City, Guangdong Province, China

The sites are constructed in conformance with the requirements of ANSI C63.7, ANSI C63.4 (2003) and CISPR Publication 22.

3.2. Test Facility

The test facility is recognized, certified, or accredited by the following organizations:

IC Registration No.: 10288A-1

The 3m alternate test site of Dongguan Dongdian Testing Service Co.,Ltd EMC Laboratory has been registered by Certification and Engineer Bureau of Industry Canada for the performance of with Registration No.: 10288A-1 on May, 2012.

FCC-Registration No.: 270092

Dongguan Dongdian Testing Service Co.,Ltd EMC Laboratory has been registered and fully described in a report filed with the (FCC) Federal Communications Commission. The acceptance letter from the FCC is maintained in our files. Registration 270092, Mar, 2015.

3.3. Environmental conditions

During the measurement the environmental conditions were within the listed ranges:

Temperature:	15-35 ° C
Humidity:	30-60 %
Atmospheric pressure:	950-1050mbar

3.4. Test Description

Test Specification clause	Test case	Test Mode	Test Channel	Recorded In Report		Pass	Fail	NA	NP	Remark
§95.639	Maximum Transmitter Power	<input checked="" type="checkbox"/> Op1 <input checked="" type="checkbox"/> Op2	<input checked="" type="checkbox"/> Middle	<input checked="" type="checkbox"/> Op1 <input checked="" type="checkbox"/> Op2	<input checked="" type="checkbox"/> Middle	<input checked="" type="checkbox"/>	<input type="checkbox"/>	<input type="checkbox"/>	<input type="checkbox"/>	Pass
§95.637 §2.1047	Modulation Characteristic	<input checked="" type="checkbox"/> Op1 <input checked="" type="checkbox"/> Op2	<input checked="" type="checkbox"/> Middle	<input checked="" type="checkbox"/> Op1 <input checked="" type="checkbox"/> Op2	<input checked="" type="checkbox"/> Middle	<input checked="" type="checkbox"/>	<input type="checkbox"/>	<input type="checkbox"/>	<input type="checkbox"/>	Pass
§95.633 §2.1049	Occupied Bandwidth	<input checked="" type="checkbox"/> Op1 <input checked="" type="checkbox"/> Op2	<input checked="" type="checkbox"/> Middle	<input checked="" type="checkbox"/> Op1 <input checked="" type="checkbox"/> Op2	<input checked="" type="checkbox"/> Middle	<input checked="" type="checkbox"/>	<input type="checkbox"/>	<input type="checkbox"/>	<input type="checkbox"/>	Pass
§95.635 §2.1049	Emission Mask	<input checked="" type="checkbox"/> Op1 <input checked="" type="checkbox"/> Op2	<input checked="" type="checkbox"/> Middle	<input checked="" type="checkbox"/> Op1 <input checked="" type="checkbox"/> Op2	<input checked="" type="checkbox"/> Middle	<input checked="" type="checkbox"/>	<input type="checkbox"/>	<input type="checkbox"/>	<input type="checkbox"/>	Pass
§95.621 §95.626 §2.1055	Frequency Stability	<input checked="" type="checkbox"/> Op1 <input checked="" type="checkbox"/> Op2	<input checked="" type="checkbox"/> Middle	<input checked="" type="checkbox"/> Op1 <input checked="" type="checkbox"/> Op2	<input checked="" type="checkbox"/> Middle	<input checked="" type="checkbox"/>	<input type="checkbox"/>	<input type="checkbox"/>	<input type="checkbox"/>	Pass
§95.635	TX spurious emissions radiated	<input checked="" type="checkbox"/> Op1 <input checked="" type="checkbox"/> Op2	<input checked="" type="checkbox"/> Middle	<input checked="" type="checkbox"/> Op1 <input checked="" type="checkbox"/> Op2	<input checked="" type="checkbox"/> Middle	<input checked="" type="checkbox"/>	<input type="checkbox"/>	<input type="checkbox"/>	<input type="checkbox"/>	Pass
§15.209(a)	TX spurious Emissions radiated < 30 MHz	<input checked="" type="checkbox"/> Op1 <input checked="" type="checkbox"/> Op2	<input checked="" type="checkbox"/> Middle	<input checked="" type="checkbox"/> Op1 <input checked="" type="checkbox"/> Op2	<input checked="" type="checkbox"/> Middle	<input checked="" type="checkbox"/>	<input type="checkbox"/>	<input type="checkbox"/>	<input type="checkbox"/>	Pass
§15.107(a) §15.207	Conducted Emissions < 30 MHz	<input checked="" type="checkbox"/> Op3	-/-	<input checked="" type="checkbox"/> Op3	-/-	<input type="checkbox"/>	<input type="checkbox"/>	<input checked="" type="checkbox"/>	<input type="checkbox"/>	Pass

Note:

1. NA = Not Applicable; NP = Not Performed;

3.5. Statement of the measurement uncertainty

The data and results referenced in this document are true and accurate. The reader is cautioned that there may be errors within the calibration limits of the equipment and facilities. The measurement uncertainty was calculated for all measurements listed in this test report acc. to CISPR 16 - 4 „Specification for radio disturbance and immunity measuring apparatus and methods – Part 4: Uncertainty in EMC Measurements“ and is documented in the Dongguan Dongdian Testing Service Co.,Ltd quality system acc. to DIN EN ISO/IEC 17025. Furthermore, component and process variability of devices similar to that tested may result in additional deviation. The manufacturer has the sole responsibility of continued compliance of the device.

Hereafter the best measurement capability for Dongguan Dongdian Testing Service Co.,Ltd laboratory is reported:

Test	Range	Measurement Uncertainty	Notes
Radiated Emission	30~1000MHz	3.16 dB	(1)
Radiated Emission	1~18GHz	3.56 dB	(1)
Conducted Disturbance	0.15~30MHz	2.44 dB	(1)

- (1) This uncertainty represents an expanded uncertainty expressed at approximately the 95% confidence level using a coverage factor of k=2.

3.6. Equipments Used during the Test

Field Strength Spurious Emissions						
Item	Test Equipment	Manufacturer	Model No.	Serial No.	Last Cal.	Cal. Interval
1	Ultra-Broadband Antenna	ShwarzBeck	VULB9163	462	2017/04/11	3 years
2	EMI TEST Receiver	Rohde&Schwarz	ESU8	100316	2016/10/25	1 years
3	EMI TEST Software	Audix	E3	6.111111	N/A	N/A
4	Horn Antenna	EMCO	3116	00060095	2017/04/11	3 years
5	Pre-Amplifier	Rohde&Schwarz	SCU-01	10049	2016/10/25	1 years
6	Pre-Amplifier	A.H.	PAM0-0118	360	2016/10/25	1 years
7	Pre-Amplifier	A.H.	PAM-1840VH	562	2016/10/25	1 years
8	Double Ridged Horn Antenna	Rohde&Schwarz	HF907	100265	2017/04/11	3 years
9	Active Loop Antenna	Schwarz beck	FMZB1519	0.38	2017/04/11	3 years
11	TURNTABLE	MATURO	TT2.0	----	N/A	N/A
12	ANTENNA MAST	MATURO	TAM-4.0-P	----	N/A	N/A
13	Spectrum Analyzer	R&S	FSU26	1166.1660.26	2016/10/25	1 years
14	RF Communication TEST SET	HP	8920A	3813A10502	2016/10/25	1 years

Modulation Characteristics						
Item	Test Equipment	Manufacturer	Model No.	Serial No.	Last Cal.	Cal. Interval
1	RF Communication TEST SET	HP	8920A	3813A10502	2016/10/25	1 years

RF Power Output & Occupied Bandwidth & Antenna Conducted Emissions						
Item	Test Equipment	Manufacturer	Model No.	Serial No.	Last Cal.	Cal. Interval
1	RF Communication TEST SET	HP	8920A	3813A10502	2016/10/25	1 years
2	Signal Spectrum Analyzer	R&S	FSU26	101961	2016/10/25	1 years
3	Attenuator	R&S	ESH3-22	100449	2016/10/25	1 years

4. TEST CONDITIONS AND RESULTS

4.1. RF POWER OUTPUT

TEST CONFIGURATION

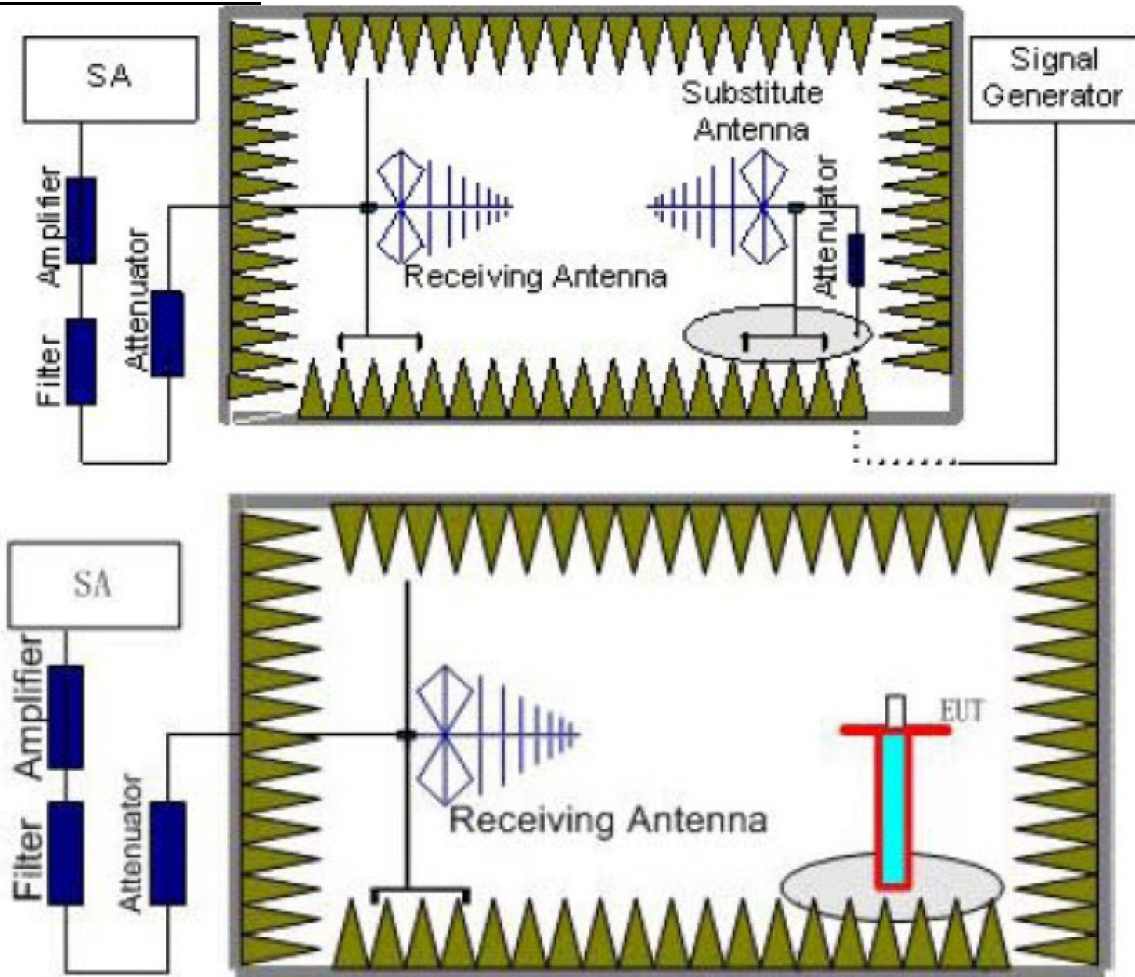

TEST PROCEDURE

1. EUT was placed on a 1.5 meter high non-conductive stand at a 3 meter test distance from the receive antenna. A receiving antenna was placed on the antenna mast 3 meters from the EUT for emission measurements. The height of receiving antenna is 1.0 m. Detected emissions were maximized at each frequency by rotating the EUT through 360° and adjusting the receiving antenna polarization. The radiated emission measurements of all transmit frequencies in six channels were measured with peak detector.
2. A log-periodic antenna or double-ridged waveguide horn antenna shall be substituted in place of the EUT. The log-periodic antenna will be driven by a signal generator and the level will be adjusted till the same power value on the spectrum analyzer or receiver. The level of the spurious emissions can be calculated through the level of the signal generator, cable loss, the gain of the substitution antenna and the reading of the spectrum analyzer or receiver.
3. The EUT is then put into continuously transmitting mode at its maximum power level during the test. Set Test Receiver or Spectrum RBW=100kHz, VBW=300kHz for 30MHz to 1GHz, And the maximum value of the receiver should be recorded as (Pr).
4. The EUT shall be replaced by a substitution antenna. In the chamber, an substitution antenna for the frequency band of interest is placed at the reference point of the chamber. An RF Signal source for the frequency band of interest is connected to the substitution antenna with a cable that has been constructed to not interfere with the radiation pattern of the antenna. A power (PMea) is applied to the input of the substitution antenna, and adjust the level of the signal generator output until the value of the receiver reach the previously recorded (Pr). The power of signal source (PMea) is recorded. The test should be performed by rotating the test item and adjusting the receiving antenna polarization.

5. A amplifier should be connected to the Signal Source output port. And the cable should be connect between the Amplifier and the Substitution Antenna. The cable loss (P_{cl}), the Substitution Antenna Gain (G_a) and the Amplifier Gain (P_{Ag}) should be recorded after test.

The measurement results are obtained as described below:

$$\text{Power(EIRP)} = P_{\text{Mea}} - P_{\text{Ag}} - P_{\text{cl}} + G_a$$

If used signal generator which signal level can up to 33dBm, so we not used power

Amplifier for substitution test; The measurement results are amend as described below:

$$\text{Power(EIRP)} = P_{\text{Mea}} - P_{\text{cl}} + G_a$$

6. This value is EIRP since the measurement is calibrated using an antenna of known gain (2.15 dBi) and known input power.

7. ERP can be calculated from EIRP by subtracting the gain of the dipole, $\text{ERP} = \text{EIRP} - 2.15 \text{dBi}$.

LIMIT

Per FCC Part § 2.1046 and Part §95.639;

- (a) No GMRS transmitter, under any condition of modulation, shall exceed:
 - (1) 50 W *Carrier power* (average TP during one unmodulated RF cycle) when transmitting emission type A1D, F1D, G1D, A3E, F3E or G3E.
 - (2) 50 W peak envelope TP when transmitting emission type H1D, J1D, R1D, H3E, J3E or R3E.
- (b) No R/C transmitter, under any condition of modulation, shall exceed a carrier power or peak envelope TP (single-sideband only) of:
 - (1) 4 W in the 26-27 MHz frequency band, except on channel frequency 27.255 MHz;
 - (2) 25 W on channel frequency 27.255 MHz;
 - (3) 0.75 W in the 72-76 MHz frequency band.
- (c) No CB transmitter, under any condition of modulation, shall exceed:
 - (1) 4 W Carrier power when transmitting emission type A1D or A3E;
 - (2) 12 W peak envelope TP when transmitting emission type H1D, J1D, R1D, H3E, J3E or R3E. Each CB transmitter which transmits emission type H3E, J3E or R3E must automatically prevent the TP from exceeding 12 W peak envelope TP or the manufacturer's rated peak envelope TP, whichever is less.
- (d) No FRS unit, under any condition of modulation, shall exceed 0.500 W effective radiated power (ERP).
- (e) The maximum transmitter output power authorized for LPRS stations is 100 mW.
- (f) In the MedRadio Service:
 - (1) For transmitters operating in the 401-406 MHz band that are not excepted under §95.627(b) from the frequency monitoring requirements of §95.627(a), the maximum radiated power in any 300 kHz bandwidth by MedRadio transmitters operating at 402-405 MHz, or in any 100 kHz bandwidth by MedRadio transmitters operating at 401-402 MHz or 405-406 MHz shall not exceed 25 microwatts EIRP. For transmitters that are excepted under §95.627(b) from the frequency monitoring requirements of §95.627(a), the power radiated by any station operating in 402-405 MHz shall not exceed 100 nanowatts EIRP confined to a maximum total emission bandwidth of 300 kHz centered at 403.65 MHz, the power radiated by any station operating in 401-401.85 MHz or 405-406 MHz shall not exceed 250 nanowatts EIRP in any 100 kHz bandwidth and the power radiated by any station operating in 401.85-402 MHz shall not exceed 25 microwatts in the 150 kHz bandwidth. See §§95.633(e).
 - (2) For transmitters operating in 413-419 MHz, 426-432 MHz, 438-444 MHz, or 451-457 MHz bands, the peak EIRP over the frequency bands of operation shall not exceed the lesser of 1 mW or $10 \log B - 7.782$ dBm, where B is the 20 dB emission bandwidth in MHz; and the peak power spectral density shall not exceed 800 microwatts per megahertz in any 1 megahertz band.
 - (3) For transmitters operating in the 2360-2390 MHz band, the maximum EIRP over the frequency bands of operation shall not exceed the lesser of 1 mW or $10 \log(B)$ dBm, where B is the 20 dB emission bandwidth in MHz.
 - (4) For transmitters operating in the 2390-2400 MHz band, the maximum EIRP over the frequency bands of operation shall not exceed the lesser of 20 mW or $16 + 10 \log(B)$ dBm, where B is the 20 dB emission bandwidth in MHz.
 - (5) The antenna associated with any MedRadio transmitter must be supplied with the transmitter and shall be considered part of the transmitter subject to equipment authorization. Compliance with these EIRP limits may be determined as set forth in §95.627(g) or §95.628(h), as applicable.
- (g) The maximum field strength authorized for WMTS stations in the 608-614 MHz band is 200 mV/m, measured at 3 meters. For stations in the 1395-1400 MHz and 1427-1429.5 MHz bands, the maximum field strength is 740 mV/m, measured at 3 meters.
- (h) No MURS unit, under any condition of modulation, shall exceed 2 Watts transmitter power output.

DSRCS-OBUs are governed under subpart L of this part, except the maximum output power for portable DSRCS-OBUs is 1.0 mW. For purposes of this paragraph, a portable is a transmitting device designed to be used so that the radiating structure(s) of the device is/are within 20 centimeters of the body of the user.

TEST RESULTS

Channel	Frequency (MHz)	P _{Mea} (dBm)	Amplifier Gain (dBi)	Path Loss	Antenna Gain	Correction (dB)	ERP (dBm)	Limit (dBm)	Polarization
4	462.6375	-8.95	31.23	1.02	4.71	2.15	23.82	33.02	H
4	462.6375	-5.86	31.23	1.02	4.71	2.15	26.91	33.02	H
11	467.6375	-9.33	31.23	1.02	4.71	2.15	23.44	26.99	V
11	467.6375	-6.74	31.23	1.02	4.71	2.15	26.03	26.99	V

4.2. Modulation Characteristics

TEST CONFIGURATION

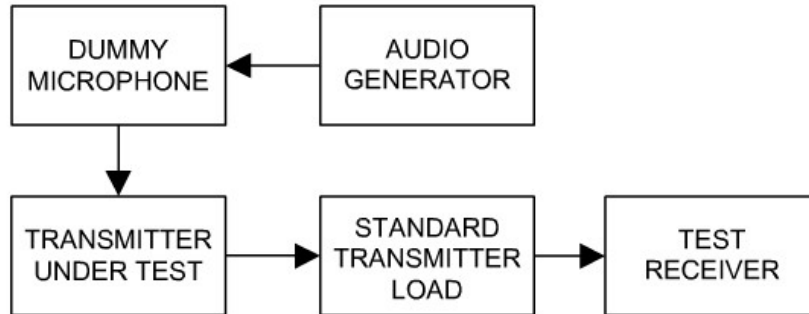

Figure 1: Modulation Limit & Audio Frequency Response

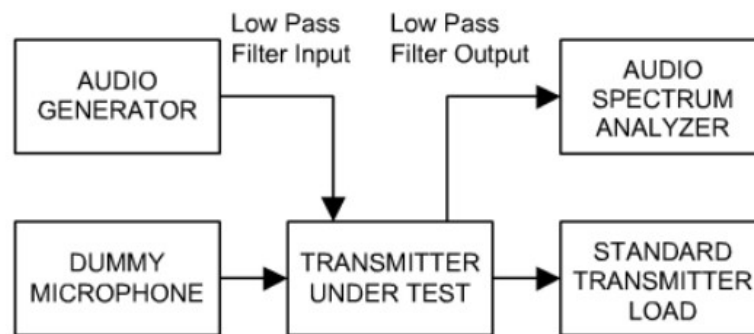

Figure 2: Audio Low Pass Filter Response

TEST PROCEDURE

Modulation Characteristics

- 1 Configure the EUT as shown in figure 1, adjust the audio input for 60% of rated system deviation at 1 KHz using this level as a reference (0dB) and vary the input level from -20 to +20dB. Record the frequency deviation obtained as a function of the input level.
- 2 Repeat step 1 with input frequency changing to 300 Hz, 500 Hz, 1000 Hz, 1500 Hz, 2500 Hz and 3000 Hz in sequence.
- 3 Recorded the frequency deviation.
- 4 The Peak frequency deviation must not exceed:
 - FRS: +/- 2.5 KHz
 - GMRS: +/- 5 KHz

Modulation Frequency Response

- 1 Configure the EUT as shown in figure 1.
- 2 Set the audio signal generator frequency to the sound pressure level at the microphone of the EUT.
- 3 The frequency of the audio signal generator is changed from 100Hz to 5 KHz.
- 4 Recorded the frequency deviation.
- 5 The Peak frequency deviation must not exceed:
 - FRS: +/- 2.5 KHz
 - GMRS: +/- 5 KHz
- 6 Calculate the audio frequency response at each frequency as:
 - Response = $20 \log_{10} (DEV_{FREQ} / DEV_{REF})$
 - DEV_{FREQ} = Frequency Deviation at 100 – 5000Hz
 - DEV_{REF} = Frequency Deviation at 1000 Hz

Audio Frequency Response

- 7 Configure the EUT as shown in figure 1.
- 8 Adjust the audio input for rated system deviation at 1 KHz using this level as a reference (0dB).

9 Vary the Audio frequency from 1 KHz to 100 KHz and record the frequency deviation.
 Audio Frequency Response = $20\log_{10}$ (Deviation of test frequency/Deviation of 1 KHz reference).

LIMIT

According to CFR47 section §95.637 modulation standards, all FCC part 95 device should meets following modulation requirement;

- (a) A GMRS transmitter that transmits emission types F1D, G1D, or G3E must not exceed a peak frequency deviation of plus or minus 5 kHz. A GMRS transmitter that transmits emission type F3E must not exceed a peak frequency deviation of plus or minus 5 kHz. A FRS unit that transmits emission type F3E must not exceed a peak frequency deviation of plus or minus 2.5 kHz, and the audio frequency response must not exceed 3.125 kHz.
- (b) Each GMRS transmitter, except a mobile station transmitter with a power output of 2.5 W or less, must automatically prevent a greater than normal audio level from causing over modulation. The transmitter also must include audio frequency low pass filtering, unless it complies with the applicable paragraphs of §95.631 (without filtering.) The filter must be between the modulation limiter and the modulated stage of the transmitter. At any frequency (f in kHz) between 3 and 20 kHz, the filter must have an attenuation of at least $60 \log_{10}(f/3)$ dB greater than the attenuation at 1 kHz. Above 20 kHz, it must have an attenuation of at least 50 dB greater than the attenuation at 1 kHz.
- (c) When emission type A3E is transmitted, the modulation must be greater than 85% but must not exceed 100%. Simultaneous amplitude modulation and frequency or phase modulation of a transmitter are not permitted.
- (d) When emission type A3E is transmitted by a CB transmitter having a TP of greater than 2.5 W, the CB transmitter must automatically prevent the modulation from exceeding 100%.
- (e) Each CB transmitter that transmits emission type H3E, J3E or R3E must be capable of transmitting the upper sideband. The capability of also transmitting the lower sideband is permitted.
- (f) DSRCS-OBUs are governed under subpart L of this part.

TEST RESULTS

4.2.1.1 Modulation Characteristics

Modulation Type: FM

GMRS @ 12.5 KHz Channel Separation @ Channel 4

Channel 4, Frequency 462.6375MHz									
Modulation Input(dBC)	Peak Frequency Deviation (KHz)							Limit(KHz)	Result
	300Hz	500Hz	1KHz	1.5KHz	2KHz	2.5KHz	3KHz		
-20	0.3	0.39	0.38	0.42	0.5	0.55	0.6	2.5	Pass
-15	0.37	0.41	0.41	0.51	0.57	0.54	0.59	2.5	Pass
-10	0.52	0.55	0.58	0.6	0.62	0.74	0.76	2.5	Pass
-5	0.63	0.71	0.9	0.83	0.92	0.93	0.96	2.5	Pass
0	1.05	1.13	1.29	1.35	1.53	1.62	1.74	2.5	Pass
5	1.25	1.47	1.53	1.84	1.91	1.94	2.13	2.5	Pass
10	1.67	1.89	1.94	2.05	2.17	2.15	2.23	2.5	Pass
15	1.84	1.97	1.99	2.22	2.22	2.27	2.32	2.5	Pass
20	2	2.09	2.17	2.22	2.24	2.22	2.35	2.5	Pass

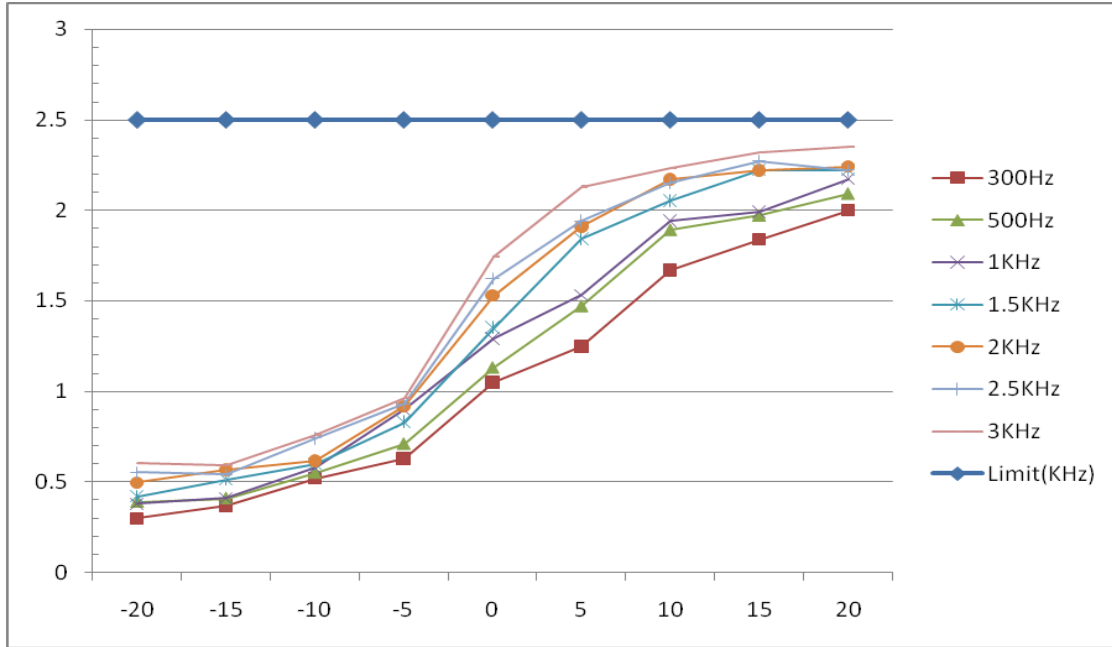

Modulation Type: FM

FRS @ 12.5 KHz Channel Separation @ Channel 11

Channel 11, Frequency 467.6375MHz									
Modulation Input(dBC)	Peak Frequency Deviation (KHz)							Limit(KHz)	Result
	300Hz	500Hz	1KHz	1.5KHz	2KHz	2.5KHz	3KHz		
-20	0.3	0.32	0.42	0.42	0.49	0.59	0.58	2.5	Pass
-15	0.46	0.46	0.45	0.51	0.54	0.55	0.57	2.5	Pass
-10	0.42	0.57	0.58	0.6	0.65	0.66	0.74	2.5	Pass
-5	0.6	0.8	0.84	0.84	0.92	0.93	0.97	2.5	Pass
0	1.04	1.17	1.32	1.34	1.56	1.65	1.77	2.5	Pass
5	1.25	1.5	1.51	1.87	1.97	2	2.21	2.5	Pass
10	1.64	1.87	1.99	2.11	2.16	2.18	2.29	2.5	Pass
15	1.81	2.03	2.04	2.14	2.17	2.24	2.31	2.5	Pass
20	2.07	2.06	2.21	2.17	2.3	2.25	2.34	2.5	Pass

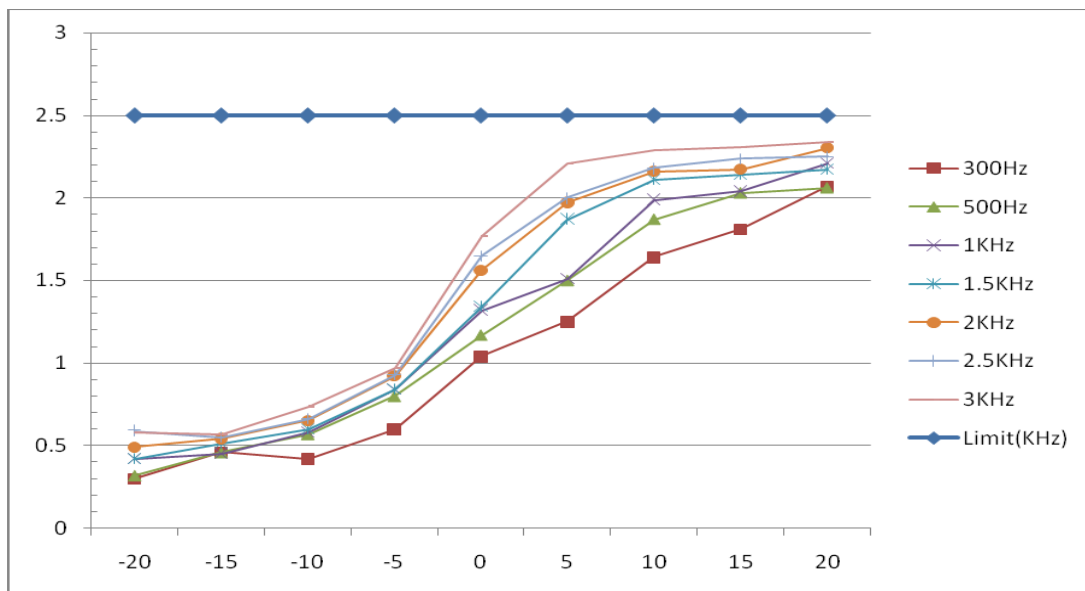

4.2.2 Modulation Frequency Response

Modulation Type: FM

GMRS @ 12.5 KHz Channel Separation @ Channel 4

Audio Frequency (KHz)	Frequency Deviation (KHz)	Limit (KHz)	Result
100	0.12	3.125	Pass
300	0.15	3.125	Pass
500	0.27	3.125	Pass
700	0.35	3.125	Pass
1000	0.5	3.125	Pass
1200	0.71	3.125	Pass
1400	0.86	3.125	Pass
1600	1.25	3.125	Pass
1800	1.59	3.125	Pass
2000	1.73	3.125	Pass
2200	1.82	3.125	Pass
2400	1.86	3.125	Pass
2600	1.89	3.125	Pass
2800	1.89	3.125	Pass
3000	1.82	3.125	Pass
3500	1.22	3.125	Pass
4000	0.69	3.125	Pass
4500	0.26	3.125	Pass
5000	0.24	3.125	Pass

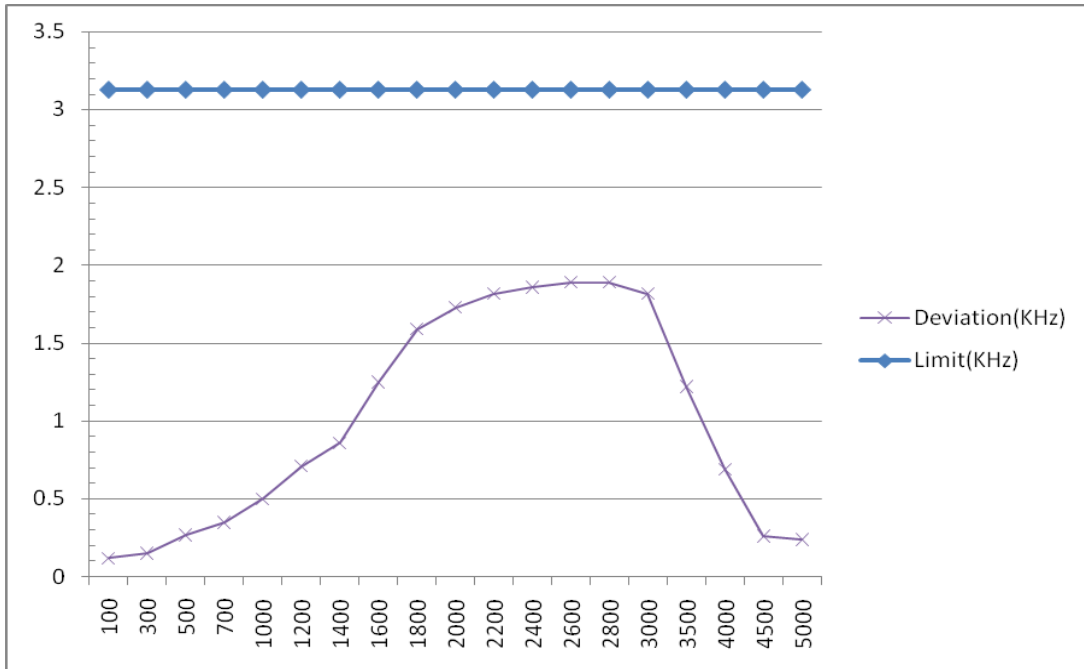

FRS @ 12.5 KHz Channel Separation @ Channel 11

Audio Frequency (KHz)	Frequency Deviation (KHz)	Limit (KHz)	Result
100	0.12	3.125	Pass
300	0.17	3.125	Pass
500	0.23	3.125	Pass
700	0.38	3.125	Pass
1000	0.5	3.125	Pass
1200	0.77	3.125	Pass
1400	0.81	3.125	Pass
1600	1.22	3.125	Pass
1800	1.43	3.125	Pass
2000	1.73	3.125	Pass
2200	1.79	3.125	Pass
2400	1.86	3.125	Pass
2600	1.87	3.125	Pass
2800	1.89	3.125	Pass
3000	1.77	3.125	Pass
3500	1.59	3.125	Pass
4000	0.53	3.125	Pass
4500	0.32	3.125	Pass
5000	0.18	3.125	Pass

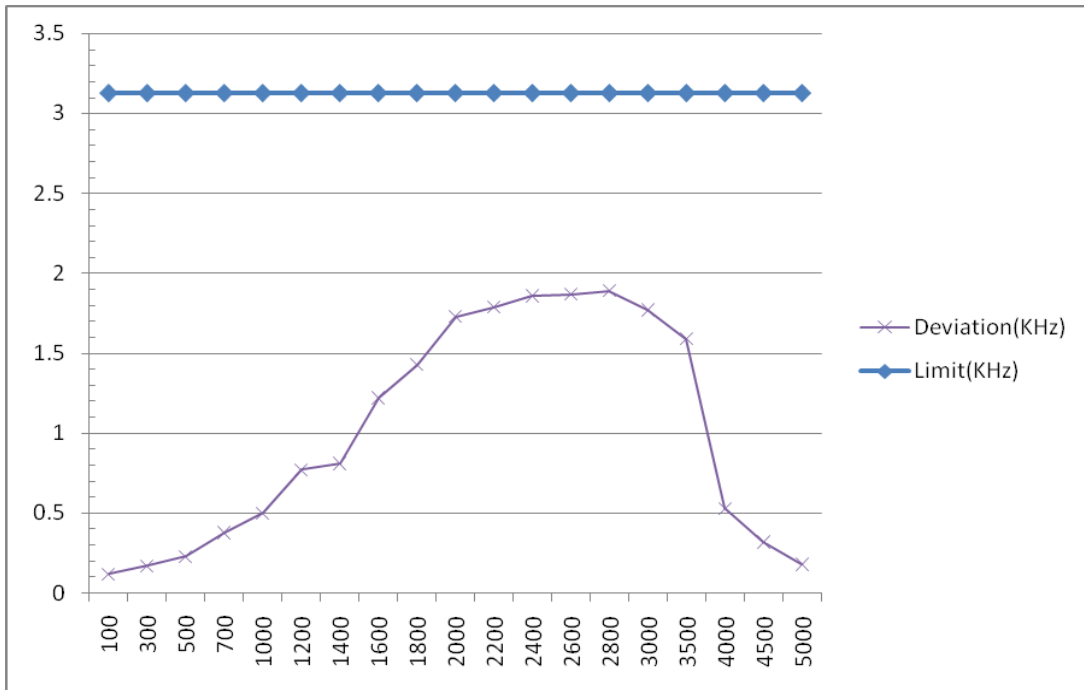

4.5.3 Audio Frequency Response

Modulation Type: FM

GMRS @ 12.5 KHz Channel Separation @ Channel 4

Audio Frequency (KHz)	dB relative to 1 KHz	Part 95.637 (b)
1	0	0.0
3	-7.0	0.0
4	-13.0	-7.5
5	-36.0	-13.3
6	-56.0	-18.1
8	-56.0	-25.6
10	-56.0	-31.4
15	-56.0	-41.9
20	-56.0	-50.0
30	-56.0	-50.0
40	-56.0	-50.0
50	-56.0	-50.0
60	-56.0	-50.0
70	-56.0	-50.0
80	-56.0	-50.0
90	-56.0	-50.0
100	-56.0	-50.0

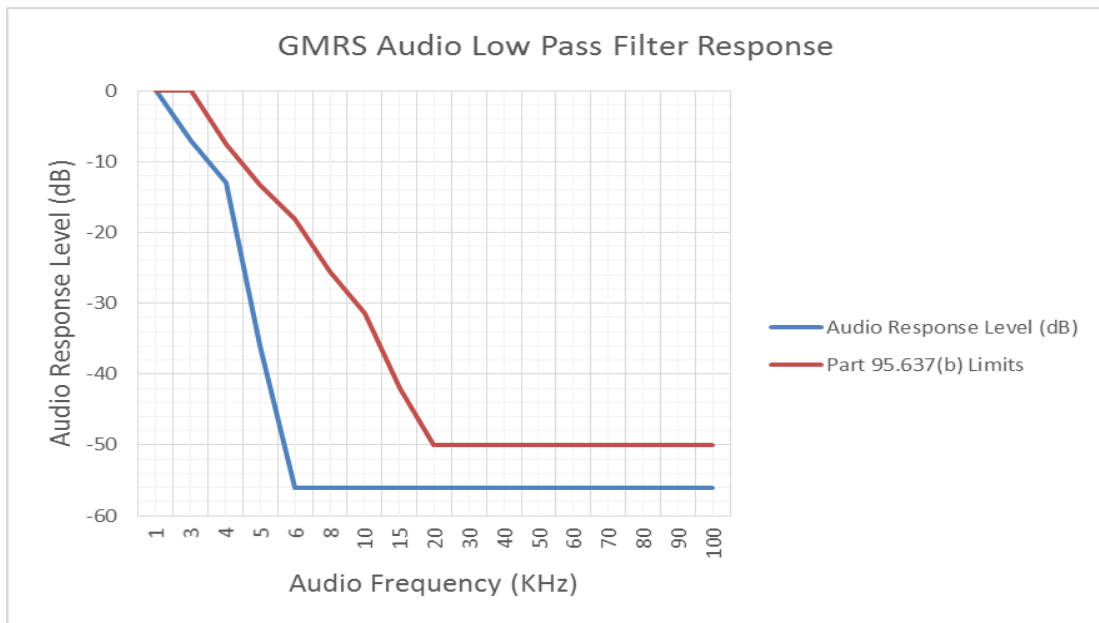

FRS @ 12.5 KHz Channel Separation @ Channel 11

Audio Frequency (KHz)	dB relative to 1 KHz	Part 95.637 (b)
1	0.0	0.0
3	-7.0	0.0
4	-13.0	-7.5
5	-36.0	-13.3
6	-56.0	-18.1
8	-56.0	-25.6
10	-56.0	-31.4
15	-56.0	-41.9
20	-56.0	-50.0
30	-56.0	-50.0
40	-56.0	-50.0
50	-56.0	-50.0
60	-56.0	-50.0
70	-56.0	-50.0
80	-56.0	-50.0
90	-56.0	-50.0
100	-56.0	-50.0

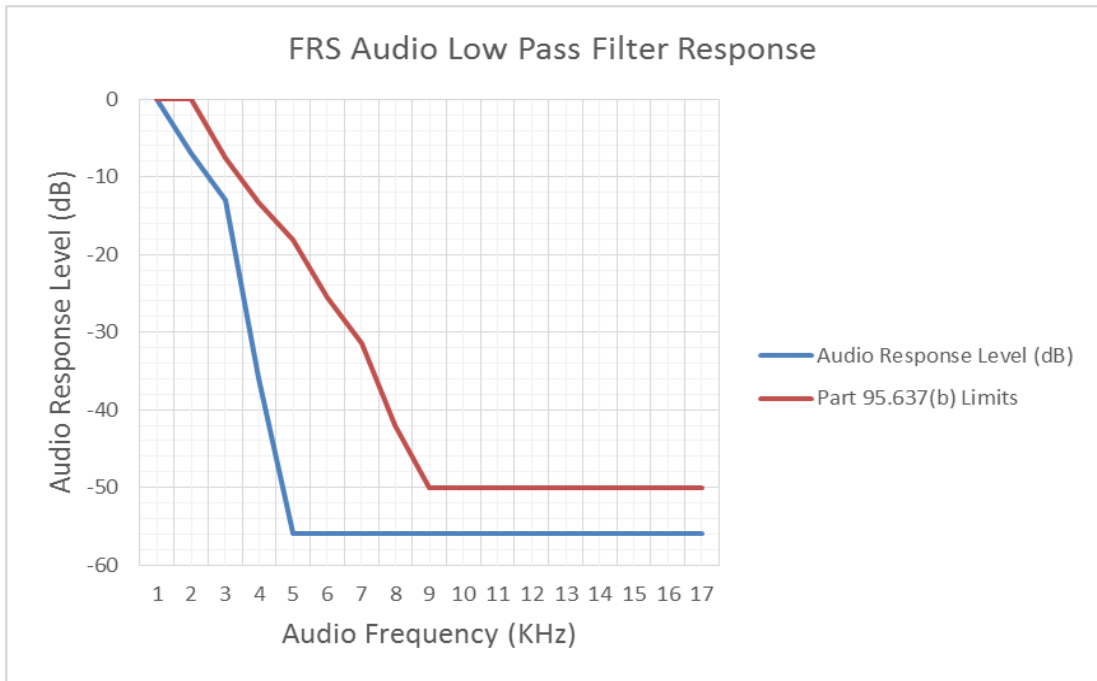

4.3. Occupied Bandwidth and Emission Mask

TEST CONFIGURATION

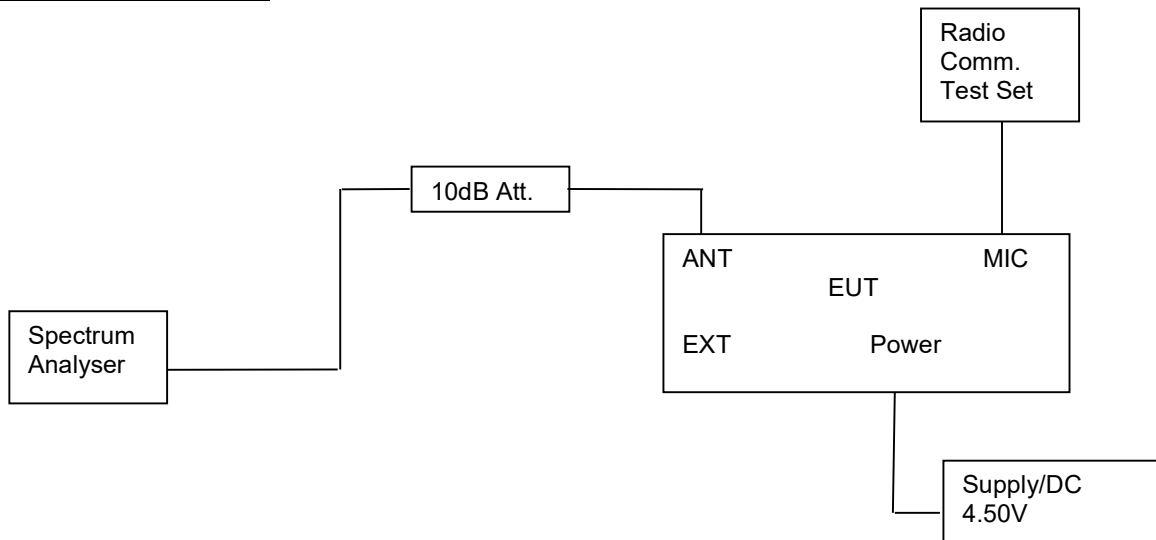

TEST PROCEDURE

- 1 The EUT was placed on a turn table which is 0.8m above ground plane.
- 2 The EUT was modulated by 2.5 KHz Sine wave audio signal; the level of the audio signal employed is 16 dB greater than that necessary to produce 50% of rated system deviation. Rated system deviation is 2.5 kHz (12.5 kHz channel spacing).
- 3 Set EUT work at continuous transmitting.
- 4 Set SPA Centre Frequency = fundamental frequency, RBW = 300Hz, VBW= 1 KHz, span =50 KHz.
- 5 Set SPA Max hold. Mark peak, Set 99% Occupied Bandwidth and 26dB Occupied Bandwidth.
- 6 Set SPA Centre Frequency=fundamental frequency, set RBW = 300 Hz, VBW =1 KHz, span = 50 KHz for 12.5 channel spacing.

LIMIT

All FCC part 95 device should be meets channel and bandwidth requirements refer to §95.633

- a. The authorized bandwidth (maximum permissible bandwidth of a transmission) for emission type H1D, J1D, R1D, H3E, J3E or R3E is 4 kHz. The authorized bandwidth for emission type A1D or A3E is 8 kHz. The authorized bandwidth for emission type F1D, G1D, F3E or G3E is 20 kHz.
- b. The authorized bandwidth for any emission type transmitted by an R/C transmitter is 8 kHz.
- c. The authorized bandwidth for emission type F3E or F2D transmitted by a FRS unit is 12.5 kHz.
- d. For transmitters in the LPRS:
 - (1) The authorized bandwidth for narrowband frequencies is 4 kHz and the channel bandwidth is 5 kHz
 - (2) The channel bandwidth for standard band frequencies is 25 kHz.
 - (3) The channel bandwidth for extra band frequencies is 50 kHz.
 - (4) AMTS stations may use the 216.750-217.000 MHz band as a single 250 kHz channel so long as the signal is attenuated as specified in §95.635(c).
- e. For transmitters in the MedRadio Service:
 - (1) For stations operating in 402-405 MHz, the maximum authorized emission bandwidth is 300 kHz. For stations operating in 401-401.85 MHz or 405-406 MHz, the maximum authorized emission bandwidth is 100 kHz. For stations operating in 401.85-402 MHz, the maximum authorized emission bandwidth is 150 kHz. For stations operating in 413-419 MHz, 426-432 MHz, 438-444 MHz, or 451-457 MHz, the maximum authorized emission bandwidth is 6 megahertz. For stations operating in 2360-2400 MHz, the maximum authorized emission bandwidth is 5 megahertz.
 - (2) Lesser emission bandwidths may be employed, provided that the unwanted emissions are attenuated as provided in §95.635. See §95.627(g), §95.628(h), and 95.639(f) regarding maximum transmitter power and measurement procedures.
 - (3) Emission bandwidth will be determined by measuring the width of the signal between points, one below the carrier center frequency and one above the carrier center frequency, that are 20 dB down relative to the maximum level of the modulated carrier. Compliance with the emission

bandwidth limit is based on the use of measurement instrumentation employing a peak detector function with an instrument resolution bandwidth approximately equal to 1.0 percent of the emission bandwidth of the device under measurement.

- f. The authorized bandwidth for any emission type transmitted by a MURS transmitter is specified as follows:
- (1) Emissions on frequencies 151.820 MHz, 151.880 MHz, and 151.940 MHz are limited to 11.25 kHz.
 - (2) Emissions on frequencies 154.570 and 154.600 MHz are limited to 20.0 kHz.
 - (3) Provided, however, that all A3E emissions are limited to 8 kHz.
- g. DSRCS-OBUs are governed under subpart L of this part.

All FCC part 95 device should be meets emission mask requirements refer to §96.635.

- (a) In addition to the procedures in part 2, the following requirements apply to each transmitter both with and without the connection of all attachments acceptable for use with the transmitter, such as an external speaker, microphone, power cord, antenna, etc.
- (b) The power of each unwanted emission shall be less than TP as specified in the applicable paragraphs listed in the following table:

Transmitter	Emission type	Applicable paragraphs (b)
GMRS	A1D, A3E, F1D, G1D, F3E, G3E with filtering	(1), (3), (7).
	A1D, A3E, F1D, G1D, F3E, G3E without filtering	(5), (6), (7).
	H1D, J1D, R1D, H3E, J3E, R3E	(2), (4), (7).
FRS	F3E with filtering	(1), (3), (7).
R/C:		
27 MHz	As specified in §95.631(b)	(1), (3), (7).
72-76 MHz	As specified in §95.631(b)	(1), (3), (7), (10), (11), (12).
CB	A1D, A3E	(1), (3), (8), (9).
	H1D, J1D, R1D, H3E, J3E, R3E	(2), (4), (8), (9).
	A1D, A3E type accepted before September 10, 1976	(1), (3), (7).
	H1D, J1D, R1D, H3E, J3E, R3E type accepted before September 10, 1986	(2), (4), (7).
LPRS	As specified in paragraph (c).	
MedRadio	As specified in paragraph (d).	
DSRCS-OBU	As specified in paragraph (f) of this section.	

- (1) At least 25 dB (decibels) on any frequency removed from the center of the authorized bandwidth by more than 50% up to and including 100% of the authorized bandwidth.
- (2) At least 25 dB on any frequency removed from the center of the authorized bandwidth by more than 50% up to and including 150% of the authorized bandwidth.
- (3) At least 35 dB on any frequency removed from the center of the authorized bandwidth by more than 100% up to and including 250% of the authorized bandwidth.
- (4) At least 35 dB on any frequency removed from the center of the authorized bandwidth by more than 150% up to and including 250% of the authorized bandwidth.
- (5) At least $83 \log_{10}(f_d/5)$ dB on any frequency removed from the center of the authorized bandwidth by a displacement frequency (f_d in kHz), of more than 5 kHz up to and including 10 kHz.
- (6) At least $116 \log_{10}(f_d/6.1)$ dB, or if less, $50 + 10 \log_{10}(T)$ dB, on any frequency removed from the center of the authorized bandwidth by a displacement frequency (f_d in kHz), of more than 10 kHz up to and including 250% of the authorized bandwidth.
- (7) At least $43 + 10 \log_{10}(T)$ dB on any frequency removed from the center of the authorized bandwidth by more than 250%.
- (8) At least $53 + 10 \log_{10}(T)$ dB on any frequency removed from the center of the authorized bandwidth by more than 250%.
- (9) At least 60 dB on any frequency twice or greater than twice the fundamental frequency.
- (10) At least 45 dB on any frequency removed from the center of the authorized bandwidth by more than 100% up to and including 125% of the authorized bandwidth.
- (11) At least 55 dB on any frequency removed from the center of the authorized bandwidth by more than 125% up to and including 250% of the authorized bandwidth.

- (12) At least $56 + 10 \log_{10}(T)$ dB on any frequency removed from the center of the authorized bandwidth by more than 250%
- (c) For transmitters designed to operate in the LPRS, emissions shall be attenuated in accordance with the following:
- (1) Emissions for LPRS transmitters operating on standard band channels (25 kHz) shall be attenuated below the unmodulated carrier in accordance with the following:
 - (i) Emissions 12.5 kHz to 22.5 kHz away from the channel center frequency: at least 30 dB; and
 - (ii) Emissions more than 22.5 kHz away from the channel center frequency: at least $43 + 10 \log(\text{carrier power in watts})$ dB
 - (2) Emissions for LPRS transmitters operating on extra band channels (50 kHz) shall be attenuated below the unmodulated carrier in accordance with the following:
 - (i) Emissions 25 kHz to 35 kHz from the channel center frequency: at least 30 dB; and
 - (ii) Emissions more than 35 kHz away from the channel center frequency: at least $43 + 10 \log(\text{carrier power in watts})$ dB
 - (3) Emissions for LPRS transmitters operating on narrowband channels (5 kHz) shall be attenuated below the power (P) of the highest emission, measured in peak values, contained within the authorized bandwidth (4 kHz) in accordance with the following:
 - (i) On any frequency within the authorized bandwidth: Zero dB
 - (ii) On any frequency removed from the center of the authorized bandwidth by a displacement frequency (f_d in kHz) of more than 2 kHz up to and including 3.75 kHz: The lesser of $30 + 20(f_d - 2)$ dB, or $55 + 10 \log(P)$, or 65 dB; and
 - (iii) On any frequency beyond 3.75 kHz removed from the center of the authorized bandwidth: At least $55 + 10 \log(P)$ dB
 - (4) Emissions from AMTS transmitters using a single 250 kHz channel shall be attenuated below the unmodulated carrier in accordance with the following:
 - (i) Emissions from 125 kHz to 135 kHz away from the channel center frequency; at least 30 dB; and
 - (ii) Emissions more than 135 kHz away from the channel center frequency; at least $43 + 10 \log(\text{carrier power in watts})$ dB
- (d) For transmitters designed to operate in the MedRadio service, emissions shall be attenuated in accordance with the following:
- (1) Emissions from a MedRadio transmitter shall be attenuated to a level no greater than the field strength limits shown in the following table when they:
 - (i) Are more than 250 kHz outside of the 402-405 MHz band (for devices designed to operate in the 402-405 MHz band)
 - (ii) Are more than 100 kHz outside of either the 401-402 MHz or 405-406 MHz bands (for devices designed to operate in the 401-402 MHz or 405-406 MHz bands)
 - (iii) Are in the 406.000-406.100 MHz band (for devices designed to operate in the 401-402 MHz or 405-406 MHz bands);
 - (iv) Are more than 2.5 MHz outside of the 413-419 MHz, 426-432 MHz, 438-444 MHz, or 451-457 MHz bands (for devices designed to operate in the 413-457 MHz band)

Frequency (MHz)	Field strength ($\mu\text{V/m}$)	Measurement distance (m)
30-88	100	3
88-216	150	3
216-960	200	3
960 and above	500	3

Note—At band edges, the tighter limit applies.

- (v) Are more than 2.5 MHz outside of the 2360-2400 MHz band (for devices designed to operate in the 2360-2400 MHz band)
- (2) The emission limits shown in the table of paragraph (d)(1) are based on measurements employing a CISPR quasi-peak detector except that above 1 GHz, the limit is based on measurements employing an average detector. Measurements above 1 GHz shall be performed using a minimum resolution bandwidth of 1 MHz. See also §95.605.
- (3) The emissions from a MedRadio transmitter must be measured to at least the tenth harmonic of the highest fundamental frequency designed to be emitted by the transmitter.
- (4) For devices designed to operate in the 402-405 MHz band: Emissions within the band more than 150 kHz away from the center frequency of the spectrum the transmission is intended to occupy and emissions 250 kHz or less below 402 MHz or above 405 MHz band will be attenuated below the maximum permitted output power by at least 20 dB.
- (5) For devices designed to operate in the 401-402 MHz or 405-406 MHz bands: Emissions between 401-401.85 MHz or 405-406 MHz within the MedRadio bands that are more than 50 kHz away

from the center frequency of the spectrum the transmission is intended to occupy (or more than 75 kHz away from the center frequency of MedRadio transmitters operating between 401.85-402 MHz) and emissions 100 kHz or less below 401 MHz or above 406 MHz shall be attenuated below the maximum permitted output power by at least 20 dB.

- (6) For devices designed to operate in the 413-419 MHz, 426-432 MHz, 438-444 MHz, and 451-457 MHz bands: In the first 2.5 megahertz beyond any of the frequency bands authorized for MMN operation, the EIRP level associated with any unwanted emission must be attenuated within a 1 megahertz bandwidth by at least 20 dB relative to the maximum EIRP level within any 1 megahertz of the fundamental emission.
 - (7) For devices designed to operate in the 2360-2400 MHz band: In the first 2.5 megahertz beyond any of the frequency bands authorized for MBAN operation, the EIRP level associated with any unwanted emission must be attenuated within a 1 megahertz bandwidth by at least 20 dB relative to the maximum EIRP level within any 1 megahertz of the fundamental emission.
 - (8) Compliance with the limits described in subparagraphs (4) through (6) are based on the use of measurement instrumentation employing a peak detector function with an instrument resolution bandwidth approximately equal to 1.0 percent of the emission bandwidth of the device under measurement.
- (e) For transmitters designed to operate in the MURS, transmitters shall comply with the following:

Frequency	Mask with audio low pass filter	Mask without audio low pass filter
151.820 MHz, 151.880 MHz and 151.940 MHz	(1)	(1)
154.570 MHz and 154.600 MHz	(2)	(3)

- (1) Emission Mask 1—For transmitters designed to operate with a 12.5 kHz channel bandwidth, any emission must be attenuated below the power (P) of the highest emission contained within the authorized bandwidth as follows:
 - (i) On any frequency from the center of the authorized bandwidth f_c to 5.625 kHz removed from f_c : Zero dB.
 - (ii) On any frequency removed from the center of the authorized bandwidth by a displacement frequency (f_d in kHz) of more than 5.625 kHz but no more than 12.5 kHz: at least $7.27(f_d - 2.88 \text{ kHz})$ dB.
 - (iii) On any frequency removed from the center of the authorized bandwidth by a displacement frequency (f_d in kHz) of more than 12.5 kHz: at least $50 + 10 \log(P)$ dB or 70 dB, whichever is the lesser attenuation.
 - (2) Emission Mask 2—For transmitters designed to operate with a 25 kHz channel bandwidth that are equipped with an audio low-pass filter, the power of any emission must be below the unmodulated carrier power (P) as follows:
 - (i) On any frequency removed from the assigned frequency by more than 50 percent, but not more than 100 percent of the authorized bandwidth: at least 25 dB
 - (ii) On any frequency removed from the assigned frequency by more than 100 percent, but not more than 250 percent of the authorized bandwidth: at least 35 dB
 - (iii) On any frequency removed from the assigned frequency by more than 250 percent of the authorized bandwidth: at least $43 + 10 \log(P)$ dB
 - (3) Emission Mask 3—For transmitters designed to operate with a 25 kHz channel bandwidth that are not equipped with an audio low-pass filter, the power of any emission must be attenuated below the unmodulated carrier output power (P) as follows:
 - (i) On any frequency removed from the center of the authorized bandwidth by a displacement frequency (f_d in kHz) of more than 5 kHz, but not more than 10 kHz: at least $83 \log(f_d/5)$ dB
 - (ii) On any frequency removed from the center of the authorized bandwidth by a displacement frequency (f_d in kHz) of more than 10 kHz, but not more than 250 percent of the authorized bandwidth: at least $29 \log(f_d^2/11)$ dB or 50 dB, whichever is the lesser attenuation
 - (iii) On any frequency removed from the center of the authorized bandwidth by more than 250 percent of the authorized bandwidth: at least $43 + 10 \log(P)$ dB
- (f) DSRCS-OBUs are governed under subpart L of this part.

TEST RESULTS

TEST RESULTS

Occupied Bandwidth					
Modulation Type	Channel Separation	Operation Mode	Test Channel	Test Frequency (MHz)	26dB Occupied Bandwidth (KHz)
GMRS/FM	12.5KHz	Op 1	CH4	462.6375	10.906
FRS/FM	12.5KHz	Op 2	CH11	467.6375	11.031
Limit			GMRS		≤20 KHz
			FRS		≤12.5 KHz
Test Results			PASS		

Emission Mask					
Modulation Type	Channel Separation	Operation Mode	Test Channel	Test Frequency (MHz)	RBW (Hz)
GMRS/FM	12.5 KHz	Op 1	CH4	462.6375	300
FRS/FM	12.5 KHz	Op 2	CH11	467.6375	300
Test Results			PASS		

Note:

1. All measured including cable loss and atten.
2. Please refer to following test plots;

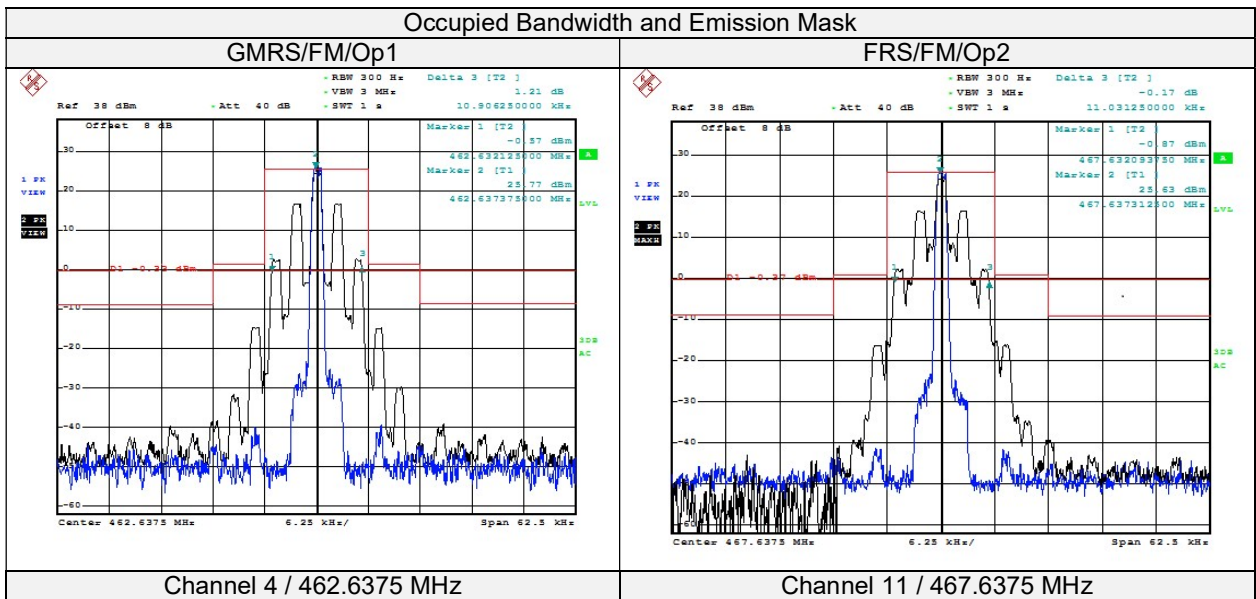

4.4. Field Strength Spurious Emissions

TEST APPLICABLE

According to the TIA/EIA 603D test method, and according to §95.635, the power of each unwanted emission shall be less than Transmitted Power as specified below:

1. At least 25 dB (decibels) on any frequency removed from the center of the authorized bandwidth by more than 50% up to and including 100% of the authorized bandwidth.
2. At least 35 dB on any frequency removed from the center of the authorized bandwidth by more than 100% up to and including 250% of the authorized bandwidth.
3. At least $43 + 10 \log_{10}(T)$ dB on any frequency removed from the center of the authorized bandwidth by more than 250%.

TEST CONFIGURATION

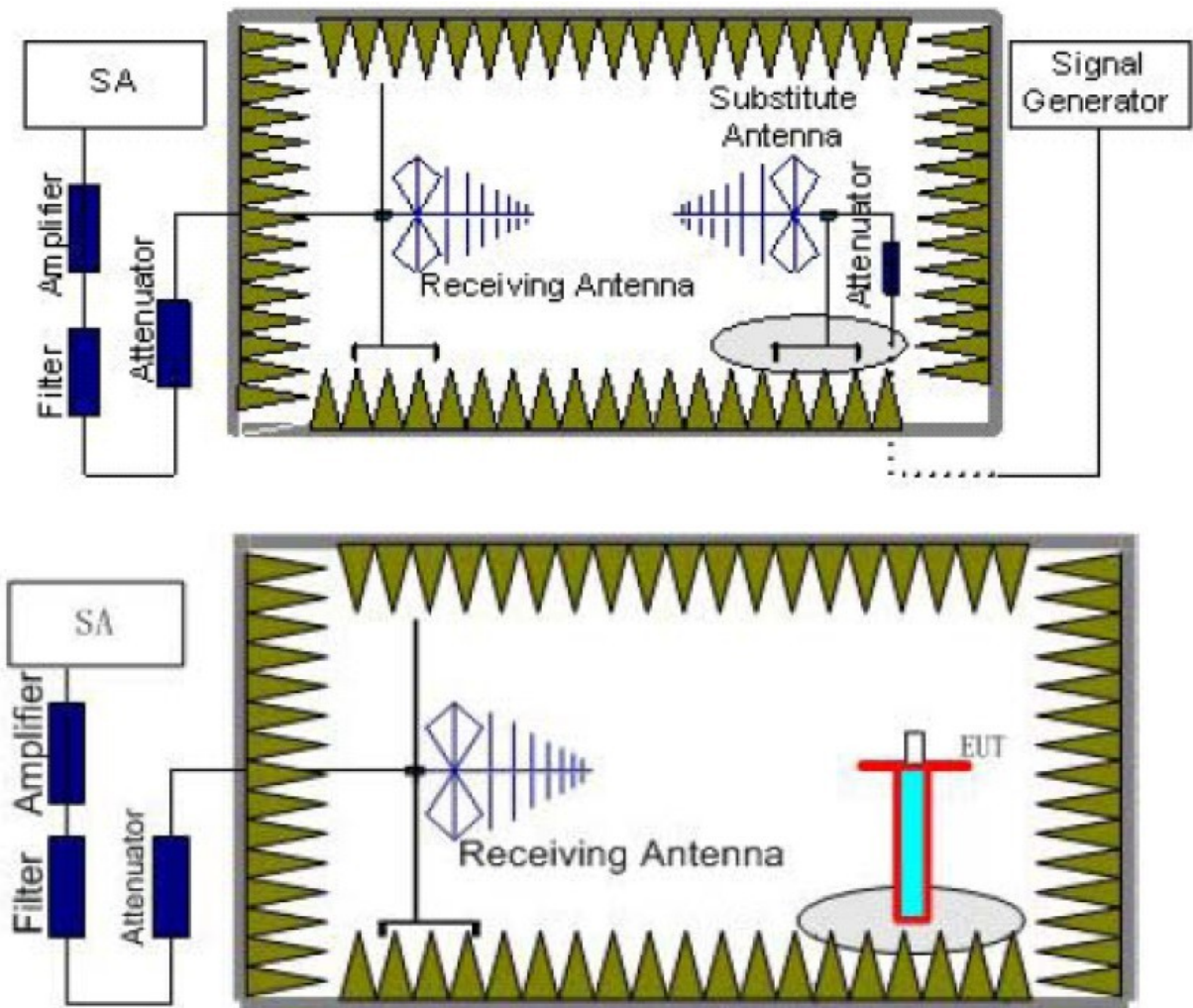

TEST PROCEDURE

1. EUT was placed on a 1.50 meter high non-conductive stand at a 3 meter test distance from the receive antenna. A receiving antenna was placed on the antenna mast 3 meters from the EUT for emission measurements. The height of receiving antenna is 1.50 m. Detected emissions were maximized at each frequency by rotating the EUT through 360° and adjusting the receiving antenna polarization. The radiated emission measurements of all transmit frequencies in six channels were measured with peak detector.
2. A log-periodic antenna or double-ridged waveguide horn antenna shall be substituted in place of the EUT. The log-periodic antenna will be driven by a signal generator and the level will be adjusted till the same power value on the spectrum analyser or receiver. The level of the spurious emissions can be calculated through the level of the signal generator, cable loss, the gain of the substitution antenna and the reading of the spectrum analyser or receiver.

4.5. Frequency Stability

TEST CONFIGURATION

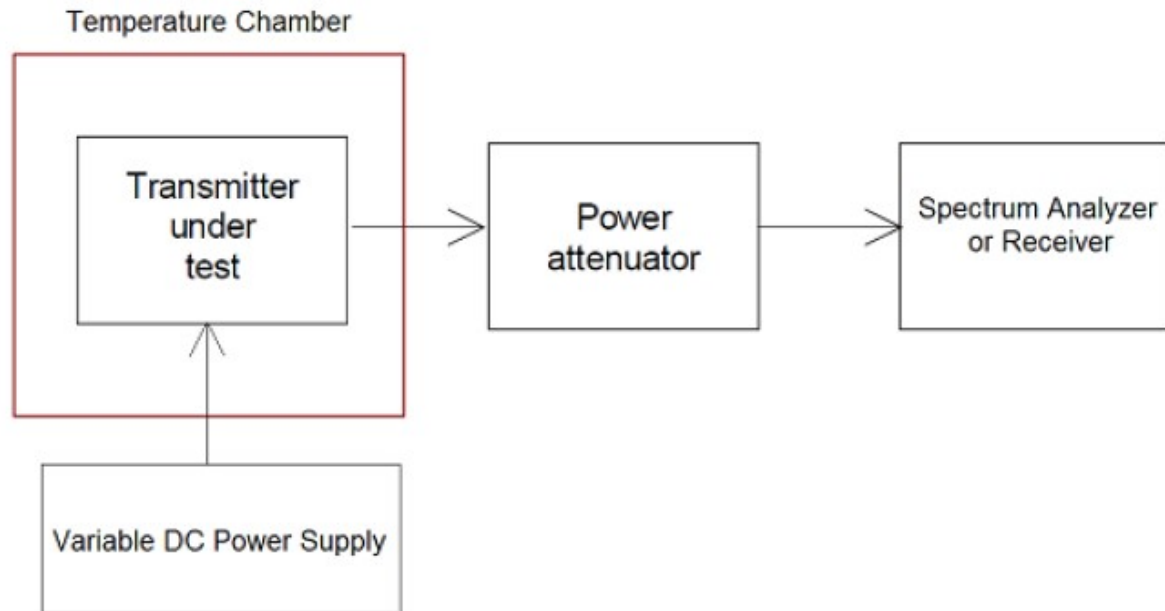

TEST PROCEDURE

The EUT was set in the climate chamber and connected to an external DC power supply. The RF output was directly connected to frequency meter. The coupling loss of the additional cables was recorded and taken in account for all the measurements. After temperature stabilization (approx. 20 min for each stage), the frequency for the lower, the middle and the highest frequency range was recorded. For Frequency stability Vs. Voltage the EUT was connected to a DC power supply and the voltage was adjusted in the required ranges. The result was recorded.

TEST APPLICABLE

- 1 According to FCC Part 2 Section 2.1055 (a)(1), the frequency stability shall be measured with variation of ambient temperature from -30°C to $+60^{\circ}\text{C}$ centigrade.
- 2 According to FCC Part 2 Section 2.1055 (a) (2), for battery powered equipment, the frequency stability shall be measured with reducing primary supply voltage to the battery operating end point, which is specified by the manufacture.
- 3 Vary primary supply voltage from 85 to 115 percent of the nominal value; if manufacturer declares extreme voltage within 85 to 115 percent of the nominal value, measured at extreme voltage declared by manufacturer.

LIMIT

According to §95.621, Each GMRS transmitter for mobile station, small base station and control station operation must be maintained within a frequency tolerance of 0.0005%. Each GMRS transmitter for base station (except small base), mobile relay station or fixed station operation must be maintained within a frequency tolerance of 0.00025%.

According to §95.625, Each FRS unit must be maintained within a frequency tolerance of 0.00025%.

TEST RESULTS

Test conditions		Frequency error (ppm)		
Voltage Condition	Temp(°C)	462.6375 MHz	462.65 MHz	467.6375 MHz
NV	-20	0.48	0.50	0.75
	-10	0.47	0.42	0.70
	0	0.46	0.36	0.63
	10	0.44	0.30	0.55
	20	0.36	0.26	0.46
	30	0.45	0.34	0.47
	40	0.51	0.39	0.54
50	0.51	0.49	0.63	
LV	20	0.41	0.29	0.48
HV	20	0.46	0.34	0.50
Limit (ppm)		2.50	2.50	5.00
Result		PASS	PASS	PASS

NV: Normal Voltage 4.5V

LV: Low Voltage 3.15V

HV: High Voltage 5.18V

.....**End of Report**.....