

## MEASUREMENT REPORT

### FCC PART 95 Walkie Talkie

---

**FCC ID:** 2ACVFM-8

**APPLICANT:** Shenzhen ChangTaiWei Electronic CO., LTD

**Application Type:** Certification

**Product:** Walkie Talkie

**Model No.:** M-8

**FCC Rule Part(s):** FCC Part 95 Subpart B

**Test Procedure(s):** ANSI/TIA-603-E: 2016  
ANSI C63.26: 2015

**Test Date:** March 05 ~ 18, 2019

Reviewed By :   
( Sunny Sun )

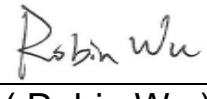
Approved By :   
( Robin Wu )



The test results relate only to the samples tested.

This equipment has been shown to be capable of compliance with the applicable technical standards as indicated in the measurement report and was tested in accordance with the measurement procedures specified in ANSI/TIA-603-E:2016 and ANSI C63.26. Test results reported herein relate only to the item(s) tested.

The test report shall not be reproduced except in full without the written approval of MRT Technology (Suzhou) Co., Ltd.

### Revision History

Report No.	Version	Description	Issue Date	Note
1903RSU001-U1	Rev. 01	Initial report	03-28-2019	Valid

## CONTENTS

Description	Page
<b>§2.1033 General Information .....</b>	<b>5</b>
<b>1. INTRODUCTION .....</b>	<b>6</b>
1.1. Scope .....	6
1.2. MRT Test Location .....	6
<b>2. PRODUCT INFORMATION .....</b>	<b>7</b>
2.1. Equipment Description.....	7
2.2. Operating Frequency and Channel List.....	7
2.3. Test Channels .....	8
2.4. Applicable standards .....	8
2.5. Test Methodology .....	8
2.6. EMI Suppression Device(s)/Modifications.....	8
2.7. Labeling Requirements.....	9
<b>3. ANTENNA REQUIREMENTS.....</b>	<b>10</b>
<b>4. TEST EQUIPMENT CALIBRATION DATE .....</b>	<b>11</b>
<b>5. MEASUREMENT UNCERTAINTY.....</b>	<b>12</b>
<b>6. TEST RESULT .....</b>	<b>13</b>
6.1. Summary .....	13
6.2. Frequency Accuracy .....	14
6.2.1. Test Limit .....	14
6.2.2. Test Procedure.....	14
6.2.3. Test Setup.....	15
6.2.4. Test Result.....	16
6.3. Transmit Power.....	18
6.3.1. Test Limit .....	18
6.3.2. Test Procedure.....	18
6.3.3. Test Setup.....	19
6.3.4. Test Result.....	20
6.4. Occupied Bandwidth.....	22
6.4.1. Test Limit .....	22
6.4.2. Test Procedure.....	22
6.4.3. Test Setup.....	22
6.4.4. Test Result.....	23
6.5. Unwanted Emissions Mask.....	24

---

6.5.1.	Test Limit .....	24
6.5.2.	Test Procedure.....	24
6.5.3.	Test Setup.....	25
6.5.4.	Test Result.....	26
6.6.	Modulation Characteristics.....	29
6.6.1.	Test Limit .....	29
6.6.2.	Test Procedure.....	30
6.6.3.	Test Setup.....	31
6.6.4.	Test Result.....	32
6.7.	Radiated Unwanted Emissions .....	41
6.7.1.	Test Limit .....	41
6.7.2.	Test Procedure.....	41
6.7.3.	Test Setup.....	42
6.7.4.	Test Result.....	44
<b>7.</b>	<b>CONCLUSION.....</b>	<b>45</b>
	<b>APPENDIX A - TEST SETUP PHOTOGRAPH .....</b>	<b>46</b>
	<b>APPENDIX B - EUT PHOTOGRAPH .....</b>	<b>47</b>

## §2.1033 General Information

<b>Applicant:</b>	Shenzhen ChangTaiWei Electronic CO., LTD		
<b>Applicant Address:</b>	5/F.,6 Block, XinGu Industrial Zone, GuShu Village, XiXiang Town, BaoAn District, Shenzhen City, China		
<b>Manufacturer:</b>	Shenzhen ChangTaiWei Electronic CO., LTD		
<b>Manufacturer Address:</b>	5/F.,6 Block, XinGu Industrial Zone, GuShu Village, XiXiang Town, BaoAn District, Shenzhen City, China		
<b>Test Site:</b>	MRT Technology (Suzhou) Co., Ltd		
<b>Test Site Address:</b>	D8 Building, No.2 Tian'edang Rd., Wuzhong Economic Development Zone, Suzhou, China		
<b>FCC Registration No.:</b>	893164		
<b>Test Device Serial No.:</b>	N/A	<input type="checkbox"/> Production	<input checked="" type="checkbox"/> Pre-Production <input type="checkbox"/> Engineering

### Test Facility / Accreditations

Measurements were performed at MRT Laboratory located in Tian'edang Rd., Suzhou, China.

- MRT facility is a FCC registered (MRT Reg. No. 893164) test facility with the site description report on file and has met all the requirements specified in ANSI C63.4-2014.
- MRT facility is an IC registered (MRT Reg. No. 11384A-1) test laboratory with the site description on file at Industry Canada.
- MRT facility is a VCCI registered (R-20025, G-20034, C-20020, T-20020) test laboratory with the site description on file at VCCI Council.
- MRT Lab is accredited to ISO 17025 by the American Association for Laboratory Accreditation (A2LA) under the American Association for Laboratory Accreditation Program (A2LA Cert. No. 3628.01) in EMC, Telecommunications, Radio and SAR testing.



# 1. INTRODUCTION

## 1.1. Scope

Measurement and determination of electromagnetic emissions (EMC) of radio frequency devices including intentional and/or unintentional radiators for compliance with the technical rules and regulations of the Federal Communications Commission and the Industry Canada Certification and Engineering Bureau.

## 1.2. MRT Test Location

The map below shows the location of the MRT LABORATORY, its proximity to the Taihu Lake. These measurement tests were conducted at the MRT Technology (Suzhou) Co., Ltd. Facility located at D8 Building, No.2 Tian'edang Rd., Wuzhong Economic Development Zone, Suzhou, China. The measurement facility compliant with the test site requirements specified in ANSI C63.4-2014.



## 2. PRODUCT INFORMATION

### 2.1. Equipment Description

Product Name:	Walkie Talkie
Model No.:	M-8
Frequency Range:	462.5625 ~ 462.7125MHz (1~7 channel) 467.5625 ~ 467.7125MHz (8~14 channel) 462.5500 ~ 462.7250MHz (15~22 channel)
Maximum Radiated Output Power:	23.15dBm
Power Supply:	Three AA batteries
Working Voltage:	3.6 ~ 4.5V
Type of Modulation:	FM
Emission Designator:	10K0F3E
Antenna Type:	Fixed external

Note: According to FCC Part 2.202 requirements, the Necessary Bandwidth is calculated as follows:

Channel Spacing = 12.5 KHz, D= 2 KHz max, K=1, M = 3 KHz

$B_n = 2M + 2DK = (2*3 + 2*2*1)$  KHz= 10 KHz

Emission Designator: 10K0F3E

### 2.2. Operating Frequency and Channel List

FRS Channel	FRS Frequency	FRS Channel	FRS Frequency
01	462.5625MHz	12	467.6625 MHz
02	462.5875 MHz	13	467.6875 MHz
03	462.6125 MHz	14	467.7125 MHz
04	462.6375 MHz	15	462.5500 MHz
05	462.6625 MHz	16	462.5750 MHz
06	462.6875 MHz	17	462.6000 MHz
07	462.7125 MHz	18	462.6250 MHz
08	467.5625 MHz	19	462.6500 MHz
09	467.5875 MHz	20	462.6750 MHz
10	467.6125 MHz	21	462.7000 MHz
11	467.6375 MHz	22	462.7250 MHz

### 2.3. Test Channels

Channel	Frequency
01	462.5625MHz
08	467.5625MHz
22	462.7250MHz

### 2.4. Applicable standards

The following report is prepared on behalf of the Shenzhen ChangTaiWei Electronic CO., LTD in accordance with FCC Part 95 Subpart A and Subpart B and FCC Part 2 of the Federal Communication Commission rules.

The objective is to determine compliance with FCC Part 95 Subpart A and Subpart B and FCC Part 2 of the Federal Communication Commission rules.

Maintenance of compliance is the responsibility of the manufacturer. Any modification of the product, which results in lowering the emission, should be checked to ensure compliance has been maintained.

### 2.5. Test Methodology

All measurements contained in this report were conducted with TIA-603-E-2016 Land Mobile FM or PM Communications Equipment Measurement and Performance Standards and ANSI C63.4-2014, American National Standard for Methods of Measurement of Radio-Noise Emissions from Low-Voltage Electrical and Electronic Equipment in the range of 9 kHz to 40 GHz.

### 2.6. EMI Suppression Device(s)/Modifications

No EMI suppression device(s) were added and no modifications were made during testing.



## **2.7. Labeling Requirements**

Per 2.1074; Docket 95-19

The label shall be permanently affixed at a conspicuous location on the device; instruction manual or pamphlet supplied to the user and be readily visible to the purchaser at the time of purchase.

However, when the device is so small wherein placement of the label with specified statement is not practical, only the FCC ID must be displayed on the device. Please see attachment for FCC ID label and label location.

### 3. ANTENNA REQUIREMENTS

**Excerpt from §95.587 of the FCC Rules/Regulations:**

The antenna of each FRS transmitter type must meet the following requirements.

- (1) The antenna must be a non-removable integral part of the FRS transmitter type.
- (2) The gain of the antenna must not exceed that of a half-wave dipole antenna.
- (3) The antenna must be designed such that the electric field of the emitted waves is vertically polarized when the unit is operated in the normal orientation.

- The antenna of this device is **permanently attached**.
- There are no provisions for connection to an external antenna.

**Conclusion:**

The unit complies with the requirement of §95.587.

#### 4. TEST EQUIPMENT CALIBRATION DATE

##### Conducted Test - TR3

Instrument	Manufacturer	Type No.	Asset No.	Cali. Interval	Cali. Due Date
Power Meter	Agilent	U2021XA	MRTSUE06030	1 year	2019/11/16
Temperature & Humidity Chamber	BAOYT	BYH-150CL	MRTSUE06051	1 year	2019/11/16
EXA Signal Analyzer	Keysight	N9020A	MRTSUE06106	1 year	2019/04/20
EXA Signal Analyzer	Keysight	N9010B	MRTSUE06452	1 year	2019/07/20
Audio Analyzer	Agilent	U8903B	MRTSUE06143	1 year	2019/08/15
Modulation Analyzer	HP	8901A	MRTSUE06098	1 year	2019/10/18
Thermohygrometer	testo	608-H1	MRTSUE06401	1 year	2019/08/15

##### Unwanted Radiated Spurious - AC1

Instrument	Manufacturer	Type No.	Asset No.	Cali. Interval	Cali. Due Date
EMI Test Receiver	R&S	ESR7	MRTSUE06001	1 year	2019/08/14
EXA Signal Analyzer	Agilent	N9020A	MRTSUE06106	1 year	2019/04/20
Loop Antenna	Schwarzbeck	FMZB 1519	MRTSUE06025	1 year	2019/06/15
Microwave System Amplifier	Agilent	83017A	MRTSUE06076	1 year	2019/11/16
Bilog Period Antenna	Schwarzbeck	VULB 9168	MRTSUE06172	1 year	2019/04/12
Broad-Band Horn Antenna	Schwarzbeck	BBHA9120D	MRTSUE06023	1 year	2019/10/20
Hygrothermograph	Testo	608-H1	MRTSUE06403	1 year	2019/08/15
Anechoic Chamber	TDK	Chamber-AC1	MRTSUE06212	1 year	2019/05/02

Software	Version	Function
e3	v 8.3.5	EMI Test Software

## 5. MEASUREMENT UNCERTAINTY

Where relevant, the following test uncertainty levels have been estimated for tests performed on the EUT as specified in CISPR 16-4-2. This uncertainty represents an expanded uncertainty expressed at approximately the 95% confidence level using a coverage factor of  $k = 2$ .

### Radiated Emission Measurement - AC1

Measuring Uncertainty for a Level of Confidence of 95% ( $U=2Uc(y)$ ):

9kHz ~ 1GHz:  $\pm 4.18\text{dB}$

1GHz ~ 18GHz:  $\pm 4.76\text{dB}$

## 6. TEST RESULT

### 6.1. Summary

**Product Name:** Walkie Talkie  
**FCC ID:** 2ACVFM-8

FCC Part Section(s)	Test Description	Test Result	Reference
§95.565, §2.1055	Frequency Accuracy	Pass	Section 6.2
§95.567, §2.1046	Transmit Power	Pass	Section 6.3
§95.573, §2.1049,	Authorized Bandwidth	Pass	Section 6.4
§95.579, §2.1049,	Unwanted Emission Mask	Pass	Section 6.5
§95.575, §2.1047,	Modulation Characteristics	Pass	Section 6.6
§95.579, §2.1053,	Radiated Spurious Emissions	Pass	Section 6.7

**Notes:**

- (1) All modes of operation were investigated. The test results shown in the following sections represent the worst case emissions.
- (2) The analyzer plots shown in this section were all taken with a correction table loaded into the analyzer. The correction table was used to account for the losses of the cables and attenuators used as part of the system to connect the EUT to the analyzer at all frequencies of interest.
- (3) Conducted testing was performed on a test bench with the antenna port of the EUT connected to the spectrum analyzer through calibrated cables and attenuators.

## **6.2. Frequency Accuracy**

### **6.2.1. Test Limit**

Each FRS transmitter type must be designed such that the carrier frequencies remain within  $\pm 2.5$  parts-per-million (ppm) of the channel center frequencies specified in §95.563 during normal operating conditions.

### **6.2.2. Test Procedure**

#### **Frequency Stability Under Temperature Variations:**

The equipment under test was powered by three AAA batteries. RF output was connected to a frequency counter or spectrum analyzer via feed through attenuators. The EUT was placed inside the temperature chamber. Set the spectrum analyzer RBW low enough to obtain the desired frequency resolution and measure EUT 20°C operating frequency as reference frequency. Turn EUT off and set the chamber temperature to highest. After the temperature stabilized for approximately 30 minutes recorded the frequency. Repeat step measure with 10°C decreased per stage until the lowest temperature reached.

#### **Frequency Stability Under Voltage Variations:**

Set chamber temperature to 20°C. Use a DC power source to power the EUT and set the voltage to rated voltage. Set the spectrum analyzer RBW low enough to obtain the desired frequency resolution and recorded the frequency.

Reduce the input voltage to the battery operating end point, record the maximum frequency change.

### 6.2.3. Test Setup

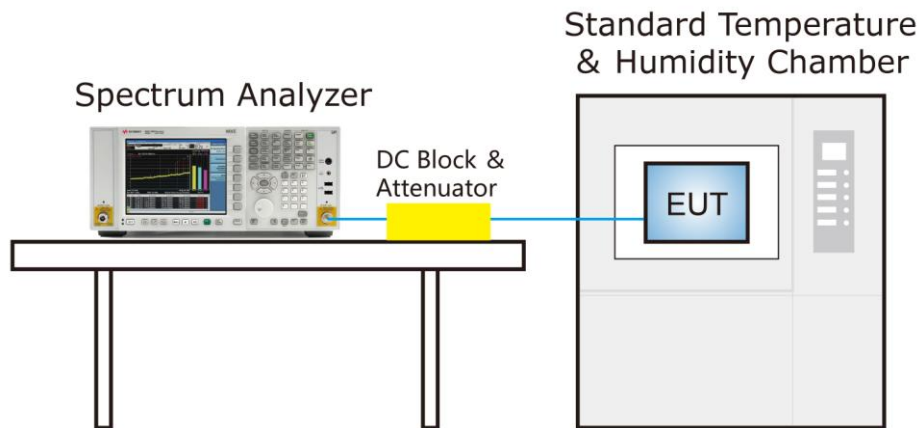

**6.2.4. Test Result**

Product	Walkie Talkie	Temperature	25°C
Test Engineer	Flag Yang	Relative Humidity	56%
Test Site	TR3	Test Date	2019/03/18

Test Channel	Test Voltage (VDC)	Test Temperature (°C)	Measured Frequency (MHz)	Frequency Deviation (ppm)	Limit (ppm)	Result
Channel 1 (462.5625MHz)	4.5	- 20	462.562863599	0.79	±2.5	Pass
		- 10	462.562851950	0.76	±2.5	Pass
		0	462.562858950	0.78	±2.5	Pass
		+ 10	462.562848934	0.75	±2.5	Pass
		+ 20 (Ref)	462.562858479	0.77	±2.5	Pass
		+ 30	462.562861313	0.78	±2.5	Pass
		+ 40	462.562858378	0.77	±2.5	Pass
		+ 50	462.562861295	0.78	±2.5	Pass
	3.6	+ 20	462.562861117	0.78	±2.5	Pass
Channel 8 (467.5625MHz)	4.5	- 20	467.562888277	0.83	±2.5	Pass
		- 10	467.562888788	0.83	±2.5	Pass
		0	467.562882483	0.82	±2.5	Pass
		+ 10	467.562880906	0.81	±2.5	Pass
		+ 20 (Ref)	467.562883213	0.82	±2.5	Pass
		+ 30	467.562880928	0.81	±2.5	Pass
		+ 40	467.562880884	0.81	±2.5	Pass
		+ 50	467.562879895	0.81	±2.5	Pass
	3.6	+ 20	467.562880035	0.81	±2.5	Pass

Note: Frequency Deviation = (Measured Frequency - Declared Frequency) / Declared Frequency\*10<sup>6</sup>.



Test Channel	Test Voltage (V)	Test Temperature (°C)	Measured Frequency (MHz)	Frequency Deviation (ppm)	Limit (ppm)	Result
Channel 22 (462.7250MHz)	4.5	-20	462.725365174	0.79	±2.5	Pass
		-10	462.725365773	0.79	±2.5	Pass
		0	462.725364560	0.79	±2.5	Pass
		10	462.725363242	0.79	±2.5	Pass
		20 (Ref)	462.725362466	0.78	±2.5	Pass
		30	462.725361201	0.78	±2.5	Pass
		40	462.725361341	0.78	±2.5	Pass
		50	462.725366065	0.79	±2.5	Pass
	3.6	20	462.725367426	0.79	±2.5	Pass

Note: Frequency Deviation = (Measured Frequency - Declared Frequency) / Declared Frequency\*10<sup>6</sup>.

## **6.3. Transmit Power**

### **6.3.1. Test Limit**

Each FRS transmitter type must be designed such that the effective radiated power (ERP) on channels 8 through 14 does not exceed 0.5 Watts and the ERP on channels 1 through 7 and 15 through 22 does not exceed 2.0 Watts.

### **6.3.2. Test Procedure**

1. On a test site, the EUT shall be placed on a turntable and in the position closest to the normal use as declared by the user.
2. The test antenna shall be oriented initially for vertical polarization located 3m from the EUT to correspond to the transmitter.
3. The output of the antenna shall be connected to the measuring receiver and either a peak or quasi-peak detector was used for the measurement as indicated on the report. The detector selection is based on how close the emission level was approaching the limit.
4. The transmitter shall be switched on; if possible, without the modulation and the measurement receiver shall be tuned to the frequency of the transmitter under test.
5. The test antenna shall be raised and lowered through the specified range of height until the measuring receiver detects a maximum signal level.
6. The transmitter shall then be rotated through 360° in the horizontal plane, until the maximum signal level is detected by the measuring receiver.
7. The test antenna shall be raised and lowered again through the specified range of height until the measuring receiver detects a maximum signal level.
8. The maximum signal level detected by the measuring receiver shall be noted.
9. The measurement shall be repeated with the test antenna set to horizontal polarization.
10. Replace the antenna with a proper Antenna (substitution antenna).
11. The substitution antenna shall be oriented for vertical polarization and, if necessary, the length of the substitution antenna shall be adjusted to correspond to the frequency of transmitting.
12. The substitution antenna shall be connected to a calibrated signal generator.
13. If necessary, the input attenuator setting of the measuring receiver shall be adjusted in order to increase the sensitivity of the measuring receiver.

14. The test antenna shall be raised and lowered through the specified range of the height to ensure that the maximum signal is received.
15. The input signal to substitution antenna shall be adjusted to the level that produces a level detected by the measuring receiver, that is equal to the level noted while the transmitter radiated power was measured, corrected for the change of input attenuation setting of the measuring receiver.
16. The input level to the substitution antenna shall be recorded as power level in dBm, corrected for any change of input attenuator setting of the measuring receiver.
17. The measurement shall be repeated with the test antenna and the substitution antenna oriented for horizontal polarization.

### 6.3.3. Test Setup

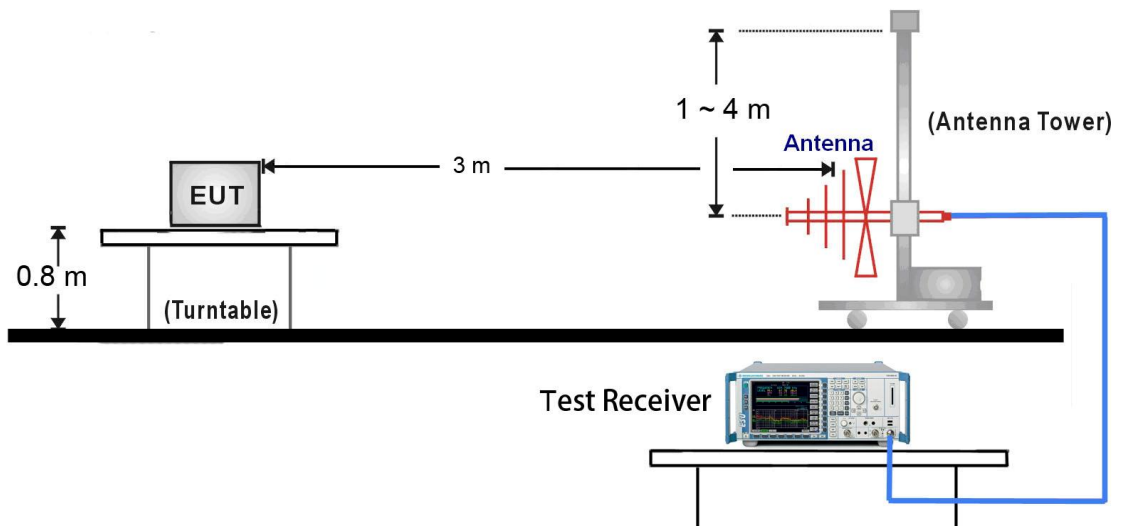

**6.3.4. Test Result**

Product	Walkie Talkie	Temperature	25°C
Test Engineer	Dandy Li	Relative Humidity	56%
Test Site	AC1	Test Date	2019/03/13
Test Item	Effective Radiated Power (ERP)		

Channel No.	Frequency (MHz)	SG Reading (dBm)	Cable Loss (dB)	Substitute Antenna Gain (dBd)	ERP (dBm)	ERP (W)	ERP Limit (W)	Result
1	462.5625	15.83	0.44	7.76	23.15	0.21	2.0	Pass
4	462.6375	15.74	0.44	7.76	23.06	0.20	2.0	Pass
7	462.7125	15.69	0.44	7.76	23.01	0.20	2.0	Pass
8	467.5625	14.17	0.44	7.76	21.49	0.14	0.5	Pass
11	467.6375	14.10	0.44	7.76	21.42	0.14	0.5	Pass
14	467.7125	14.13	0.44	7.76	21.45	0.14	0.5	Pass
15	462.5500	15.80	0.44	7.76	23.12	0.21	2.0	Pass
19	462.6500	15.68	0.44	7.76	23.00	0.20	2.0	Pass
22	462.7250	15.69	0.44	7.76	23.01	0.20	2.0	Pass

Note: ERP (dBm) = SG Reading (dBm) - Cable Loss (dB) + Substitute Antenna Gain (dBd)

Product	Walkie Talkie	Temperature	25°C
Test Engineer	Hunk Li	Relative Humidity	56%
Test Site	AC1	Test Date	2019/03/15
Test Item	Conducted Power		

Channel	Frequency (MHz)	Power (dBm)		Result
		Measured Power	Declared Power	
1	462.5625	31.01	31.5	Pass
2	462.5875	31.04	31.5	Pass
3	462.6125	31.06	31.5	Pass
4	462.6375	31.05	31.5	Pass
5	462.6625	31.02	31.5	Pass
6	462.6875	31.09	31.5	Pass
7	462.7125	31.08	31.5	Pass
8	467.5625	27.36	28.0	Pass
9	467.5875	27.31	28.0	Pass
10	467.6125	27.32	28.0	Pass
11	467.6375	27.36	28.0	Pass
12	467.6625	27.38	28.0	Pass
13	467.6875	27.40	28.0	Pass
14	467.7125	27.35	28.0	Pass
15	462.5500	30.52	31.0	Pass
16	462.5750	30.58	31.0	Pass
17	462.6000	30.52	31.0	Pass
18	462.6250	30.57	31.0	Pass
19	462.6500	30.59	31.0	Pass
20	462.6750	30.54	31.0	Pass
21	462.7000	30.60	31.0	Pass
22	462.7250	30.56	31.0	Pass

## 6.4. Occupied Bandwidth

### 6.4.1. Test Limit

Each FRS transmitter type must be designed such that the occupied bandwidth does not exceed 12.5 kHz.

### 6.4.2. Test Procedure

1. The set-up test equipment in the following configuration:
2. Setting the SPA Center Frequency = fundamental frequency,
3. Set span for the spectrum analyzer shall be set wide enough to capture all modulation products including the emission skirts (typically a span of 1.5 x OBW is sufficient)
4.  $RBW = 1\% \text{ to } 5\%$  of the anticipated OBW,  $VBW \geq 3 * RBW$ ,
5. Sweep = auto, Detector function = peak, Trace = max hold
6. Set 99% Occupied Bandwidth and 26dB Bandwidth
7. Measure and record the results in the test report.

### 6.4.3. Test Setup

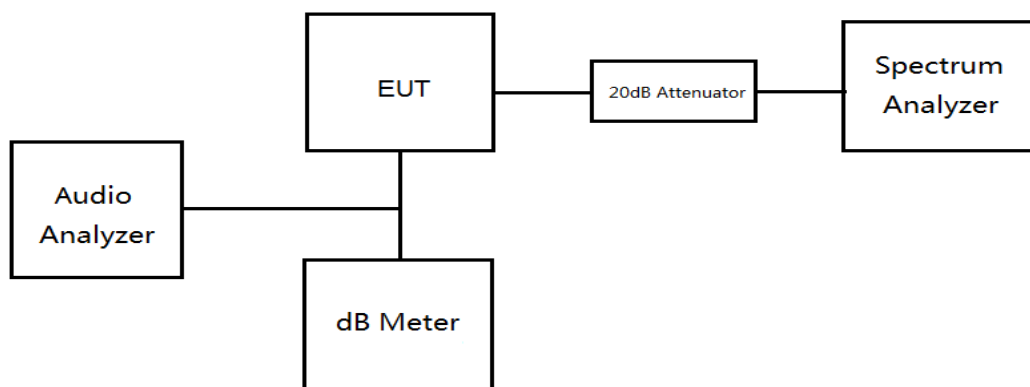

### 6.4.4. Test Result

Product	Walkie Talkie	Temperature	25°C
Test Engineer	Flag Yang	Relative Humidity	58%
Test Site	TR3	Test Date	2019/03/18
Remark	99% Occupied Bandwidth & 26dB Bandwidth		

Channel No.	Frequency (MHz)	99% Occupied Bandwidth (KHz)	26dB Bandwidth (KHz)	Limit (KHz)	Result
01	462.5625	2.14	2.24	≤ 12.5	Pass
08	467.5625	2.14	2.24	≤ 12.5	Pass
22	462.7250	2.14	2.23	≤ 12.5	Pass

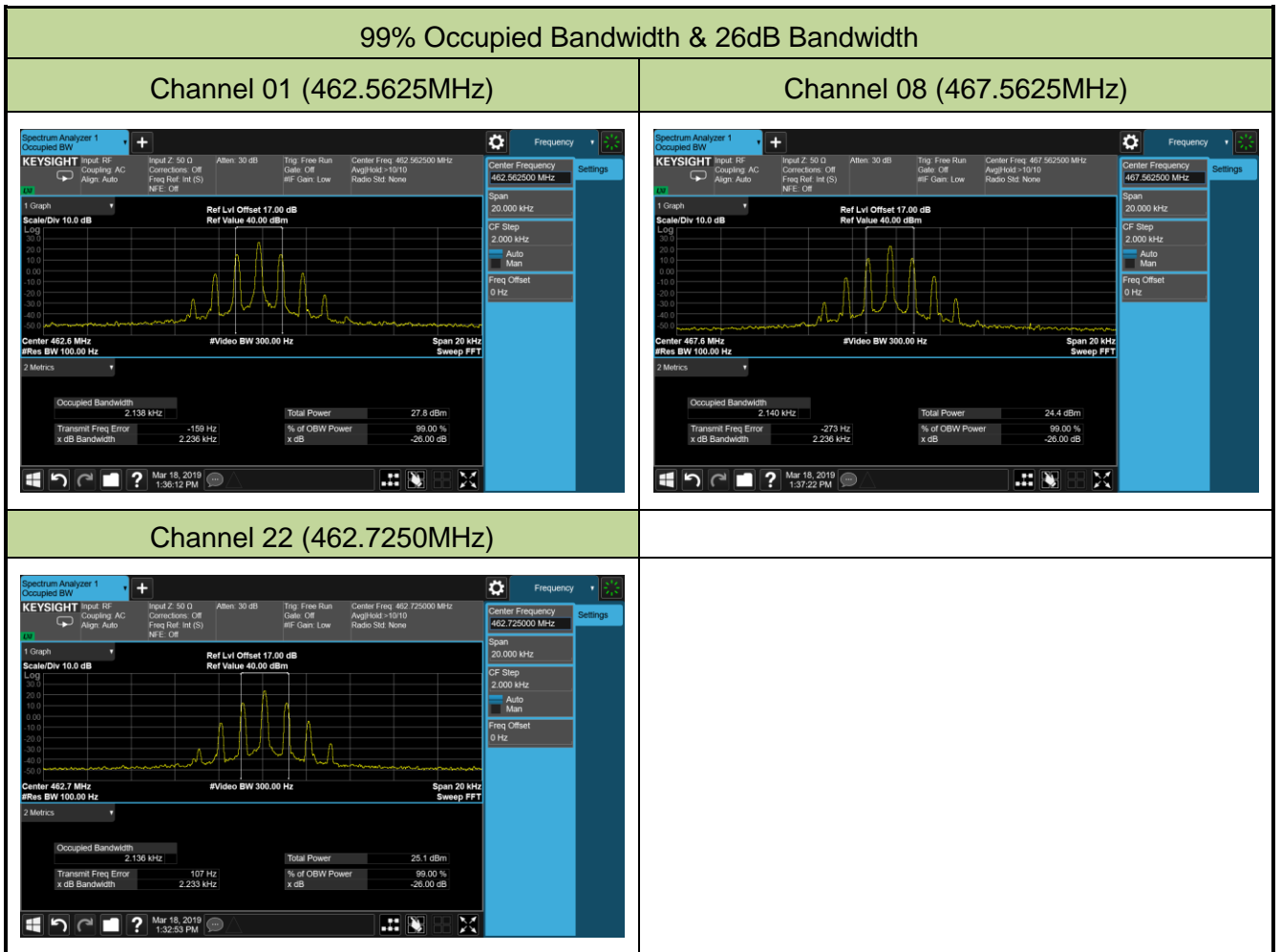

## **6.5. Unwanted Emissions Mask**

### **6.5.1. Test Limit**

Each FRS transmitter type must be designed to satisfy the applicable unwanted emissions limits in this paragraph.

(a) Attenuation requirements. The power of unwanted emissions must be attenuated below the carrier power output in Watts ( $P$ ) by at least:

- (1) 25 dB (decibels) in the frequency band 6.25 kHz to 12.5 kHz removed from the channel center frequency.
- (2) 35 dB in the frequency band 12.5 kHz to 31.25 kHz removed from the channel center frequency.
- (3)  $43 + 10 \log (P)$  dB in any frequency band removed from the channel center frequency by more than 31.25 kHz

### **6.5.2. Test Procedure**

1. Connect a signal generator to the input of the EUT.
2. Configure the signal generator to transmit the applicable radio service signal.
3. Configure the signal level to be just below the AGC threshold.
4. Connect a spectrum analyzer to the output of the EUT using appropriate attenuation.
5. Set the spectrum analyzer center frequency to the nominal EUT channel center frequency. The span range for the spectrum analyzer shall be between  $2 \times \text{OBW}$  and  $5 \times \text{OBW}$ .
6. The nominal RBW shall be 300 Hz for 16K0F3E and 100 Hz for all other emissions types.
7. Set the reference level of the spectrum analyzer to level as  $f_0$ .
8. Set spectrum analyzer detection mode to peak, and the trace mode to max hold.
9. Confirm the signal is within the appropriate emissions mask.
10. Capture the emissions mask plot for inclusion in the test report.
11. Repeat step d) to step j) with input signal amplitude set at 3 dB above the AGC threshold



12. Repeat step b) to step k) for all operational bands and emissions types.
13. Measure the input signal for all operational bands and emission types and include results in the test report.

### 6.5.3. Test Setup

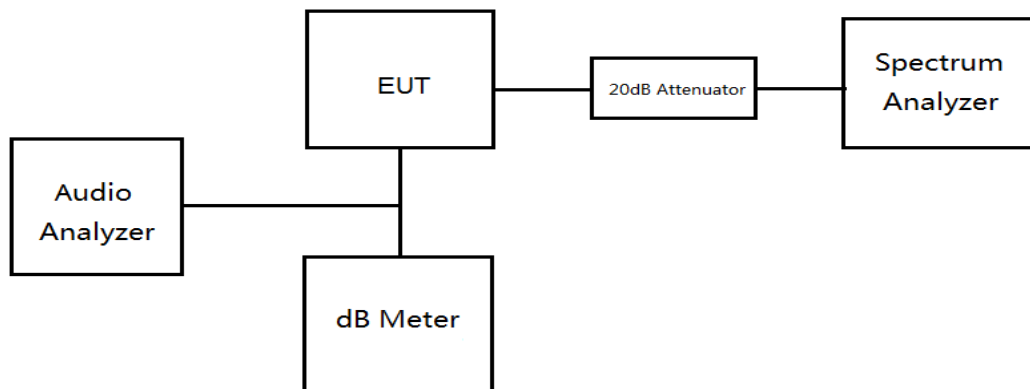

### 6.5.4. Test Result

Product	Walkie Talkie	Temperature	25°C
Test Engineer	Milo Li	Relative Humidity	59%
Test Site	TR3	Test Date	2019/03/18

**Channel 01 (462.5625MHz)**

Mask	Spurious Emission																																																								
Spurious Emission	<table border="1" style="font-size: small; margin-top: 10px;"> <thead> <tr> <th>Mode</th> <th>Trace</th> <th>Scale</th> <th>X</th> <th>Y</th> <th>Function</th> <th>Function Width</th> <th>Function Value</th> </tr> </thead> <tbody> <tr> <td>1</td> <td>N</td> <td>1</td> <td>463.05 MHz</td> <td>-34.67 dBm</td> <td></td> <td></td> <td></td> </tr> <tr> <td>2</td> <td>N</td> <td>1</td> <td>925.14 MHz</td> <td>-33.48 dBm</td> <td></td> <td></td> <td></td> </tr> <tr> <td>3</td> <td>N</td> <td>1</td> <td>1.38769 GHz</td> <td>-33.46 dBm</td> <td></td> <td></td> <td></td> </tr> <tr> <td>4</td> <td></td> <td></td> <td></td> <td></td> <td></td> <td></td> <td></td> </tr> <tr> <td>5</td> <td></td> <td></td> <td></td> <td></td> <td></td> <td></td> <td></td> </tr> <tr> <td>6</td> <td></td> <td></td> <td></td> <td></td> <td></td> <td></td> <td></td> </tr> </tbody> </table>	Mode	Trace	Scale	X	Y	Function	Function Width	Function Value	1	N	1	463.05 MHz	-34.67 dBm				2	N	1	925.14 MHz	-33.48 dBm				3	N	1	1.38769 GHz	-33.46 dBm				4								5								6							
Mode	Trace	Scale	X	Y	Function	Function Width	Function Value																																																		
1	N	1	463.05 MHz	-34.67 dBm																																																					
2	N	1	925.14 MHz	-33.48 dBm																																																					
3	N	1	1.38769 GHz	-33.46 dBm																																																					
4																																																									
5																																																									
6																																																									

Channel 08 (467.5625MHz)

Mask

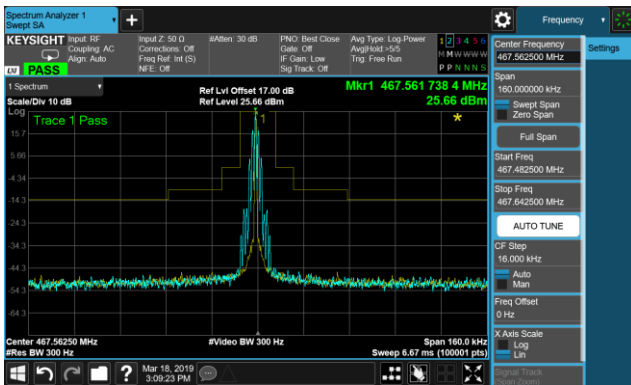

Spurious Emission

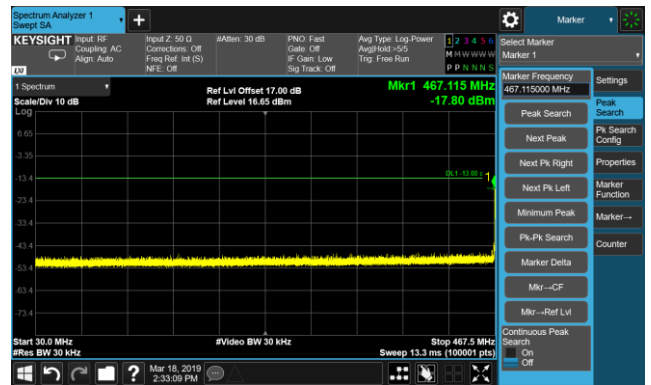

Spurious Emission

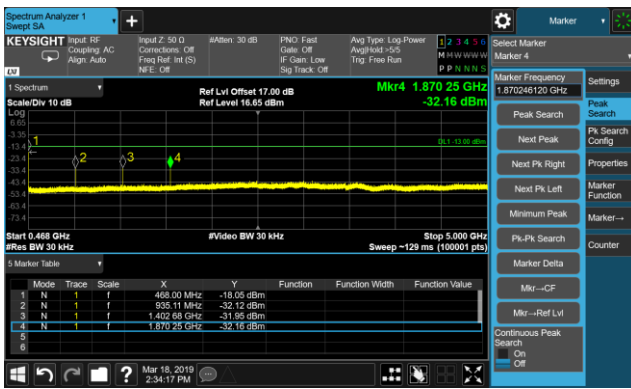

Channel 22 (462.7250MHz)

Mask

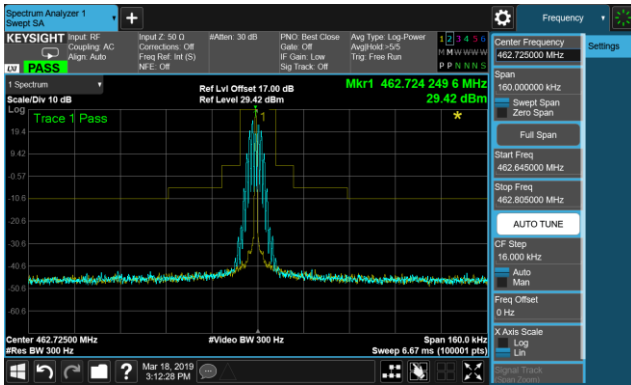

Spurious Emission

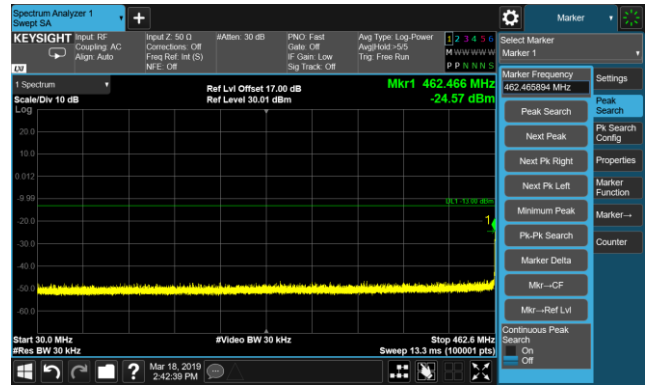

Spurious Emission



## 6.6. Modulation Characteristics

### 6.6.1. Test Limit

Each FRS transmitter type must be designed such that the peak frequency deviation does not exceed 2.5 kHz, and the highest audio frequency contributing substantially to modulation must not exceed 3.125 kHz.

Voice modulated communication equipment. A curve or equivalent data showing the frequency response of the audio modulating circuit over a range of 100 to 5000 Hz shall be submitted.

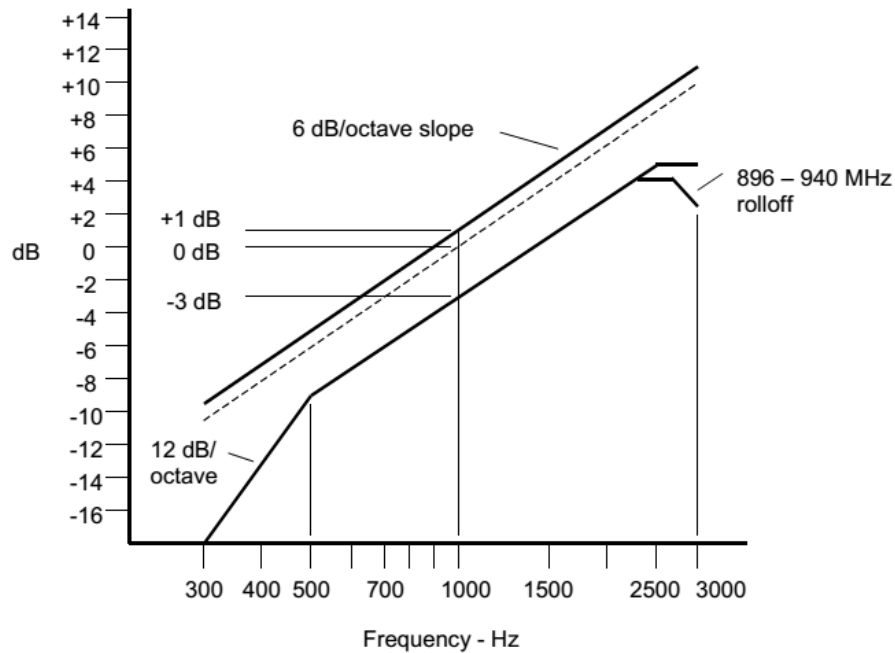

### Audio Frequency Response Limit

An additional 6 dB per octave attenuation is allowed from 2500 Hz to 3000 Hz in equipment operating in the 25 MHz to 869 MHz range.

## 6.6.2. Test Procedure

### Frequency deviation

1. Configure the EUT as shown in figure 1, adjust the audio input for 60% of rated system deviation at 1 KHz using this level as a reference (0dB) and vary the input level from –20 to +20dB. Record the frequency deviation obtained as a function of the input level.
2. Repeat step (1) with input frequency changing to 500, 1000, 2500 and 3125Hz in sequence.

### Modulation Frequency Response

1. Configure the EUT as shown in figure 1.
2. Adjust the audio signal generator frequency to the sound pressure level 107dB SPL at the microphone of the EUT.
3. Vary the Audio frequency from 100 Hz to 5 KHz and record the frequency deviation.
4. The peak frequency deviation must not exceed 2.5 KHz.

### Audio Frequency Response

1. Connect the equipment in figure 2.
2. Set the test receiver to measure peak positive deviation. Set the audio bandwidth for  $\leq 50$  Hz to  $\geq 15,000$  Hz. Turn the de-emphasis function off.
3. Adjust the transmitter per the manufacturer's procedure for full rated system deviation.
4. Apply a 1000 Hz tone and adjust the audio frequency generator to produce 20% of the rated system deviation.
5. Set the test receiver to measure rms deviation and record the deviation reading as  $DEV_{REF}$ .
6. Set the audio frequency generator to the desired test frequency between 300 Hz and 3000Hz.
7. Record the test receiver deviation reading as  $DEV_{FREQ}$ .
8. Calculate the audio frequency response at the present frequency as:

$$\text{Audio Frequency Response} = 20 \cdot \log_{10}(DEV_{FREQ} / DEV_{REF})$$

9. Repeat steps 6 through 8 for all the desired test frequencies.

### 6.6.3. Test Setup

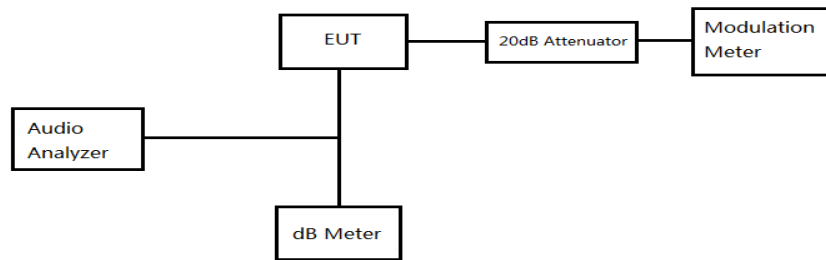

Figure 1

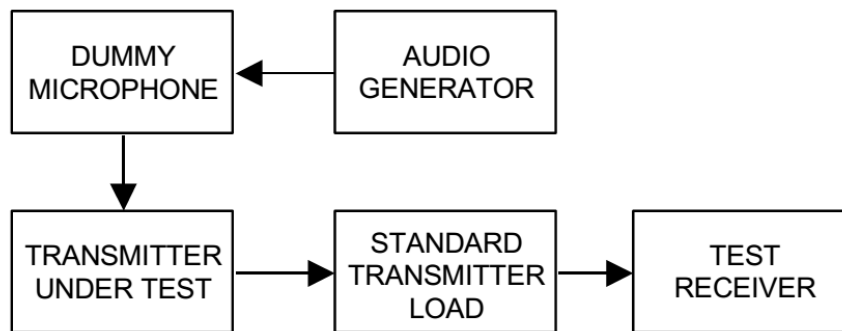
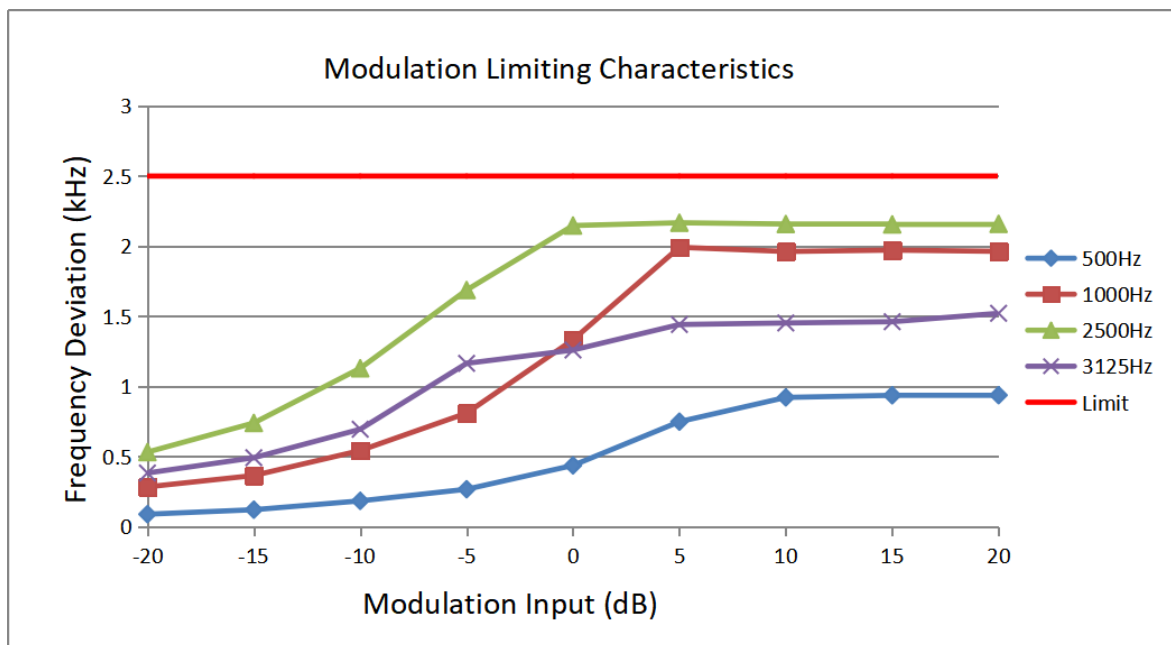

Figure 2

### 6.6.4. Test Result

Product	Walkie Talkie	Temperature	25°C
Test Engineer	Milo Li	Relative Humidity	59%
Test Site	TR3	Test Date	2019/03/13
Test Item	Frequency Deviation		

Channel 01 (462.5625MHz)					
Modulation Input (dB)	Peak Frequency Deviation (kHz) at 500Hz	Peak Frequency Deviation (kHz) at 1000Hz	Peak Frequency Deviation (kHz) at 2500Hz	Peak Frequency Deviation (kHz) at 3125Hz	Limit (kHz)
-20.00	0.088	0.283	0.531	0.382	2.5
-15.00	0.120	0.364	0.739	0.491	2.5
-10.00	0.183	0.542	1.129	0.694	2.5
-5.00	0.266	0.809	1.687	1.164	2.5
0.00	0.436	1.332	2.147	1.259	2.5
5.00	0.748	1.992	2.167	1.441	2.5
10.00	0.921	1.962	2.158	1.452	2.5
15.00	0.936	1.972	2.155	1.461	2.5
20.00	0.937	1.963	2.159	1.521	2.5





Product	Walkie Talkie	Temperature	25°C
Test Engineer	Milo Li	Relative Humidity	59%
Test Site	TR3	Test Date	2019/03/13
Test Item	Frequency Deviation		

Channel 08 (467.5625MHz)					
Modulation Input (dB)	Peak Frequency Deviation (kHz) at 500Hz	Peak Frequency Deviation (kHz) at 1000Hz	Peak Frequency Deviation (kHz) at 2500Hz	Peak Frequency Deviation (kHz) at 3125Hz	Limit (kHz)
-20.00	0.163	0.311	0.624	0.412	2.50
-15.00	0.129	0.492	0.753	0.524	2.50
-10.00	0.221	0.618	1.236	0.811	2.50
-5.00	0.232	0.882	1.797	1.288	2.50
0.00	0.469	1.398	2.251	1.397	2.50
5.00	0.823	1.987	2.224	1.542	2.50
10.00	0.987	1.941	2.238	1.634	2.50
15.00	1.156	1.993	2.243	1.657	2.50
20.00	1.224	1.982	2.257	1.723	2.50

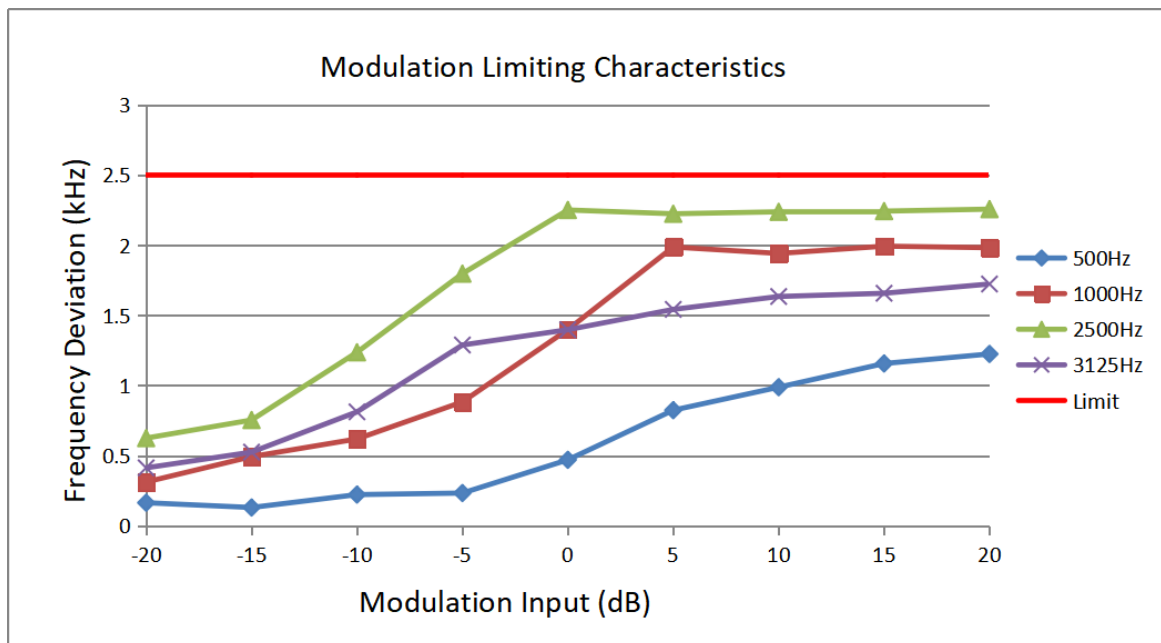

Product	Walkie Talkie	Temperature	25°C
Test Engineer	Milo Li	Relative Humidity	59%
Test Site	TR3	Test Date	2019/03/13
Test Item	Frequency Deviation		

Channel 22 (462.7250MHz)					
Modulation Input (dB)	Peak Frequency Deviation (kHz) at 500Hz	Peak Frequency Deviation (kHz) at 1000Hz	Peak Frequency Deviation (kHz) at 2500Hz	Peak Frequency Deviation (kHz) at 3125Hz	Limit (kHz)
-20.00	0.199	0.341	0.732	0.371	2.50
-15.00	0.135	0.511	0.988	0.477	2.50
-10.00	0.213	0.838	1.335	0.716	2.50
-5.00	0.312	0.913	1.813	1.054	2.50
0.00	0.511	1.349	2.114	1.243	2.50
5.00	0.744	1.814	2.086	1.445	2.50
10.00	0.997	1.883	2.113	1.466	2.50
15.00	1.113	1.973	2.122	1.437	2.50
20.00	1.257	1.992	2.155	1.466	2.50

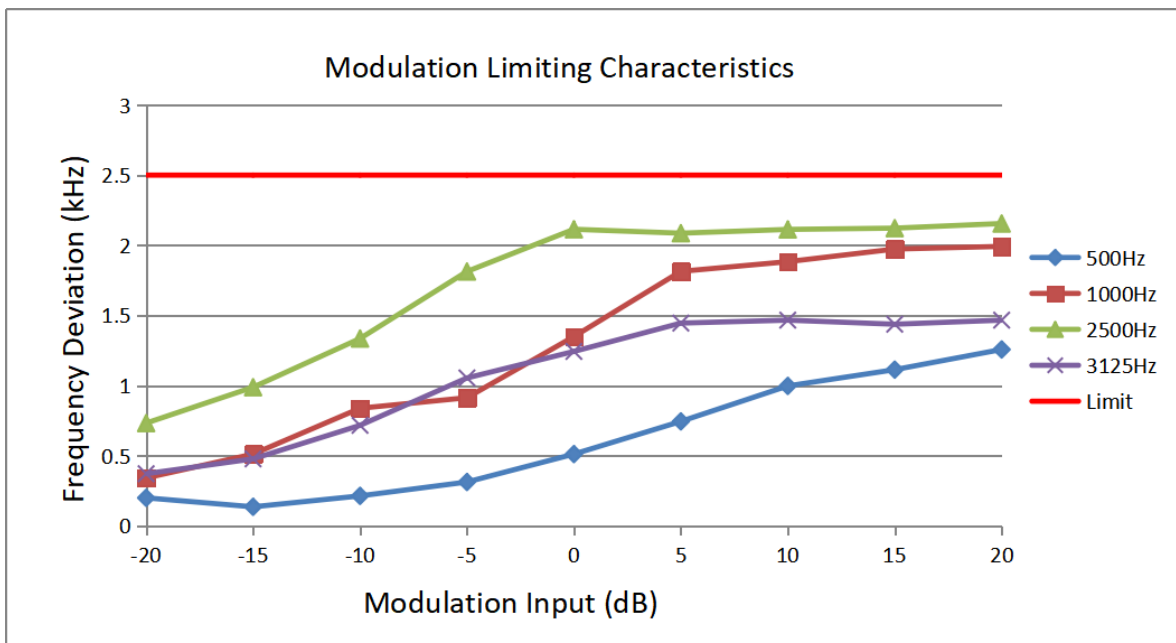



Product	Walkie Talkie	Temperature	25°C
Test Engineer	Milo Li	Relative Humidity	59%
Test Site	TR3	Test Date	2019/03/13
Test Item	Audio Frequency Response		

Channel 01 (462.5625MHz)				
Modulation Frequency (Hz)	Audio Frequency Response (dB)	Lower Limit	Upper Limit	Result
100	-22.58	--	--	Pass
200	-25.47	--	--	Pass
300	-13.04	-17.84	-9.42	Pass
400	-10.28	-12.86	-6.93	Pass
500	-7.88	-9.00	-5.00	Pass
600	-4.28	-7.42	-3.42	Pass
700	-4.78	-6.09	-2.09	Pass
800	-2.96	-4.93	-0.93	Pass
900	-2.01	-3.91	0.09	Pass
1000	-1.78	-3.00	1.00	Pass
1200	1.66	-1.42	2.58	Pass
1400	2.53	-0.09	3.91	Pass
1600	2.84	1.07	5.07	Pass
1800	4.76	2.09	6.09	Pass
2000	5.89	3.00	7.00	Pass
2100	5.42	3.42	7.42	Pass
2200	6.15	3.83	7.83	Pass
2300	7.12	4.21	8.21	Pass
2400	7.68	4.58	8.58	Pass
2500	7.71	4.93	8.93	Pass
2600	8.24	4.59	9.27	Pass
2700	7.69	4.27	9.60	Pass
2800	7.73	3.95	9.91	Pass
2900	8.82	3.65	10.22	Pass
3000	7.55	3.35	10.51	Pass
3500	8.36	--	--	Pass
4000	-15.24	--	--	Pass
5000	-18.19	--	--	Pass

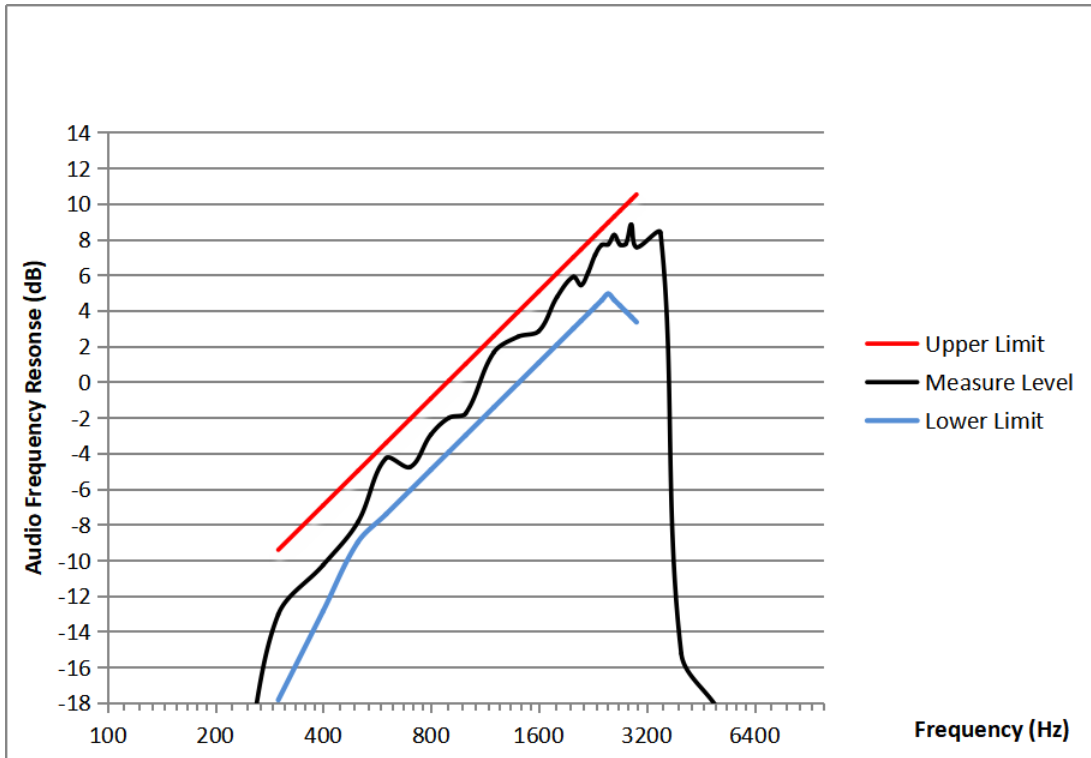



Product	Walkie Talkie	Temperature	25°C
Test Engineer	Milo Li	Relative Humidity	59%
Test Site	TR3	Test Date	2019/03/13
Test Item	Audio Frequency Response		

Channel 08 (467.5635MHz)				
Modulation Frequency (Hz)	Audio Frequency Response (dB)	Lower Limit	Upper Limit	Result
100	-23.14	--	--	Pass
200	-26.47	--	--	Pass
300	-14.13	-17.84	-9.42	Pass
400	-10.28	-12.86	-6.93	Pass
500	-8.02	-9.00	-5.00	Pass
600	-6.11	-7.42	-3.42	Pass
700	-5.13	-6.09	-2.09	Pass
800	-2.98	-4.93	-0.93	Pass
900	-2.99	-3.91	0.09	Pass
1000	-1.56	-3.00	1.00	Pass
1200	1.69	-1.42	2.58	Pass
1400	2.83	-0.09	3.91	Pass
1600	4.05	1.07	5.07	Pass
1800	5.11	2.09	6.09	Pass
2000	5.78	3.00	7.00	Pass
2100	6.19	3.42	7.42	Pass
2200	6.22	3.83	7.83	Pass
2300	7.55	4.21	8.21	Pass
2400	7.63	4.58	8.58	Pass
2500	7.81	4.93	8.93	Pass
2600	8.11	4.59	9.27	Pass
2700	7.96	4.27	9.60	Pass
2800	7.98	3.95	9.91	Pass
2900	9.03	3.65	10.22	Pass
3000	8.11	3.35	10.51	Pass
3500	7.83	--	--	Pass
4000	-12.44	--	--	Pass
5000	-15.68	--	--	Pass

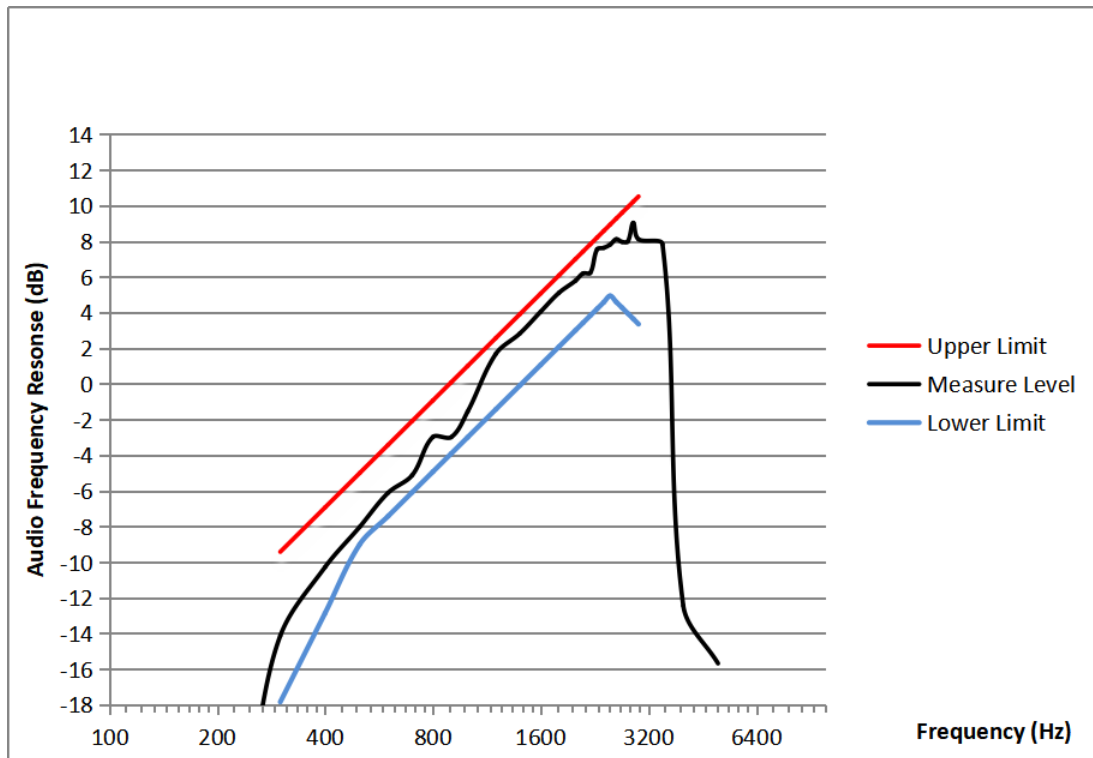



Product	Walkie Talkie	Temperature	25°C
Test Engineer	Milo Li	Relative Humidity	59%
Test Site	TR3	Test Date	2019/03/13
Test Item	Audio Frequency Response		

Channel 22 (462.7250MHz)				
Modulation Frequency (Hz)	Audio Frequency Response (dB)	Lower Limit	Upper Limit	Result
100	-27.32	--	--	Pass
200	-26.69	--	--	Pass
300	-15.36	-17.84	-9.42	Pass
400	-10.68	-12.86	-6.93	Pass
500	-6.58	-9.00	-5.00	Pass
600	-5.36	-7.42	-3.42	Pass
700	-4.99	-6.09	-2.09	Pass
800	-3.26	-4.93	-0.93	Pass
900	-2.14	-3.91	0.09	Pass
1000	-1.58	-3.00	1.00	Pass
1200	1.03	-1.42	2.58	Pass
1400	2.11	-0.09	3.91	Pass
1600	3.47	1.07	5.07	Pass
1800	4.96	2.09	6.09	Pass
2000	5.98	3.00	7.00	Pass
2100	5.45	3.42	7.42	Pass
2200	5.24	3.83	7.83	Pass
2300	6.71	4.21	8.21	Pass
2400	6.16	4.58	8.58	Pass
2500	7.36	4.93	8.93	Pass
2600	7.93	4.59	9.27	Pass
2700	7.22	4.27	9.60	Pass
2800	7.71	3.95	9.91	Pass
2900	7.26	3.65	10.22	Pass
3000	8.47	3.35	10.51	Pass
3500	10.88	--	--	Pass
4000	-15.63	--	--	Pass
5000	-17.28	--	--	Pass

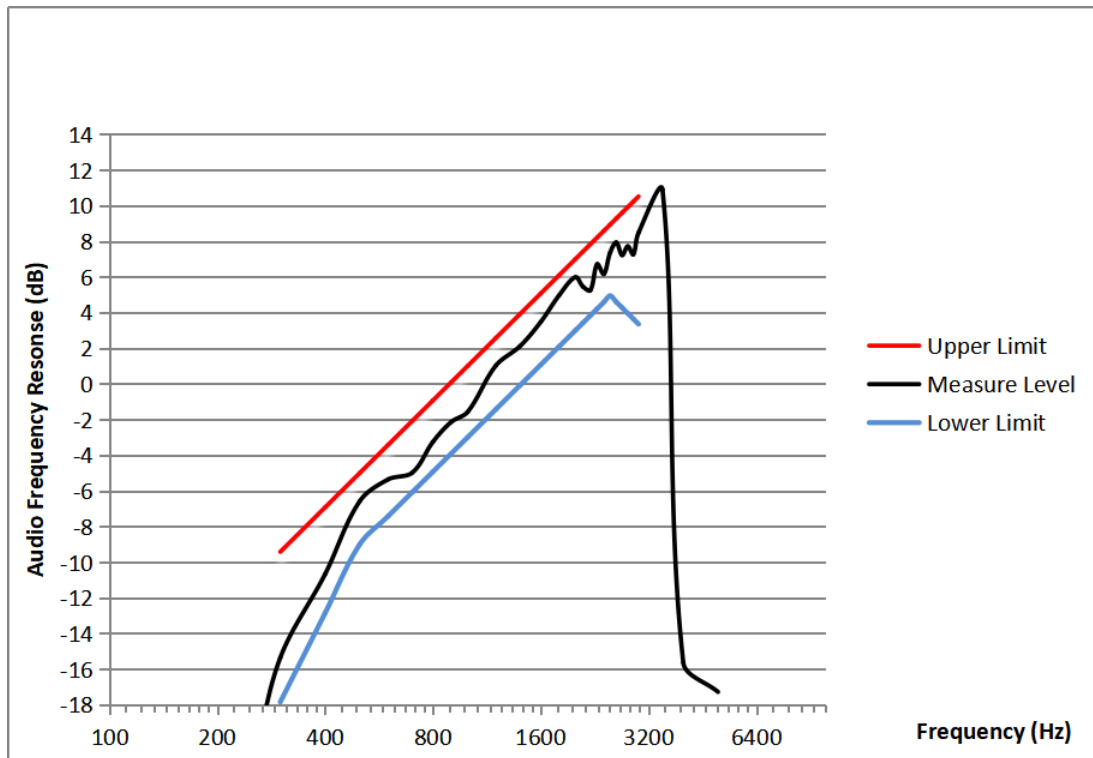



## **6.7. Radiated Unwanted Emissions**

### **6.7.1. Test Limit**

The unwanted emission should be attenuated below the carrier power output in Watts (P) by at least  $43+10 \log (P)$  dB.

### **6.7.2. Test Procedure**

1. On a test site, the EUT shall be placed on a turntable and in the position closest to the normal use as declared by the user.
2. The test antenna shall be oriented initially for vertical polarization located 3m from the EUT to correspond to the transmitter.
3. The output of the antenna shall be connected to the measuring receiver and either a peak or quasi-peak detector was used for the measurement as indicated on the report. The detector selection is based on how close the emission level was approaching the limit.
4. The transmitter shall be switched on; if possible, without the modulation and the measurement receiver shall be tuned to the frequency of the transmitter under test.
5. The test antenna shall be raised and lowered through the specified range of height until the measuring receiver detects a maximum signal level.
6. The transmitter shall then be rotated through 360° in the horizontal plane, until the maximum signal level is detected by the measuring receiver.
7. The test antenna shall be raised and lowered again through the specified range of height until the measuring receiver detects a maximum signal level.
8. The maximum signal level detected by the measuring receiver shall be noted.
9. The measurement shall be repeated with the test antenna set to horizontal polarization.
10. Replace the antenna with a proper Antenna (substitution antenna).
11. The substitution antenna shall be oriented for vertical polarization and, if necessary, the length

- of the substitution antenna shall be adjusted to correspond to the frequency of transmitting.
12. The substitution antenna shall be connected to a calibrated signal generator.
  13. If necessary, the input attenuator setting of the measuring receiver shall be adjusted in order to increase the sensitivity of the measuring receiver.
  14. The test antenna shall be raised and lowered through the specified range of the height to ensure that the maximum signal is received.
  15. The input signal to substitution antenna shall be adjusted to the level that produces a level detected by the measuring receiver, that is equal to the level noted while the transmitter radiated power was measured, corrected for the change of input attenuation setting of the measuring receiver.
  16. The input level to the substitution antenna shall be recorded as power level in dBm, corrected for any change of input attenuator setting of the measuring receiver.
  17. The measurement shall be repeated with the test antenna and the substitution antenna oriented for horizontal polarization.

### 6.7.3. Test Setup

#### 30MHz ~ 1GHz Test Setup:

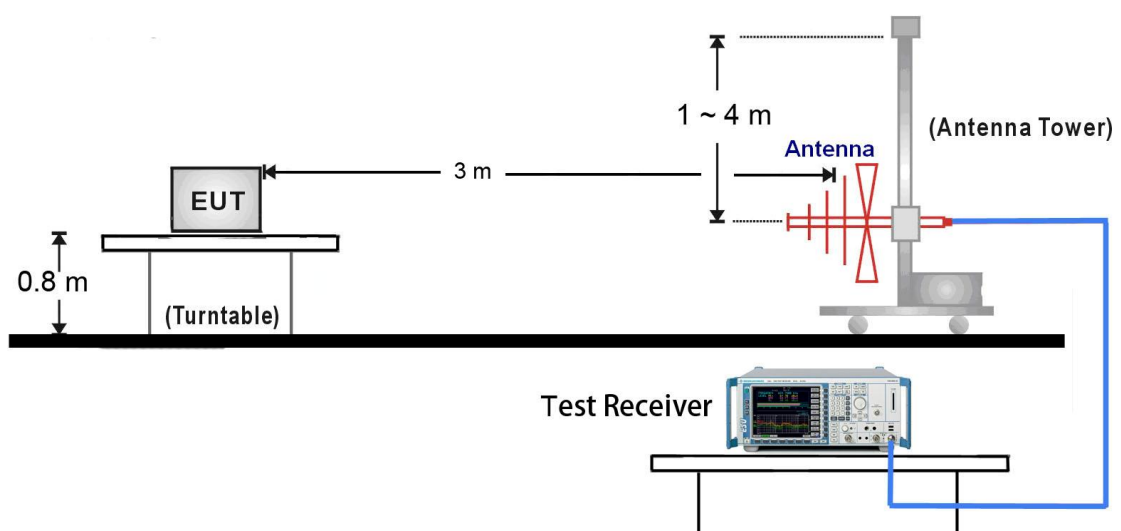

Above 1GHz Test Setup:

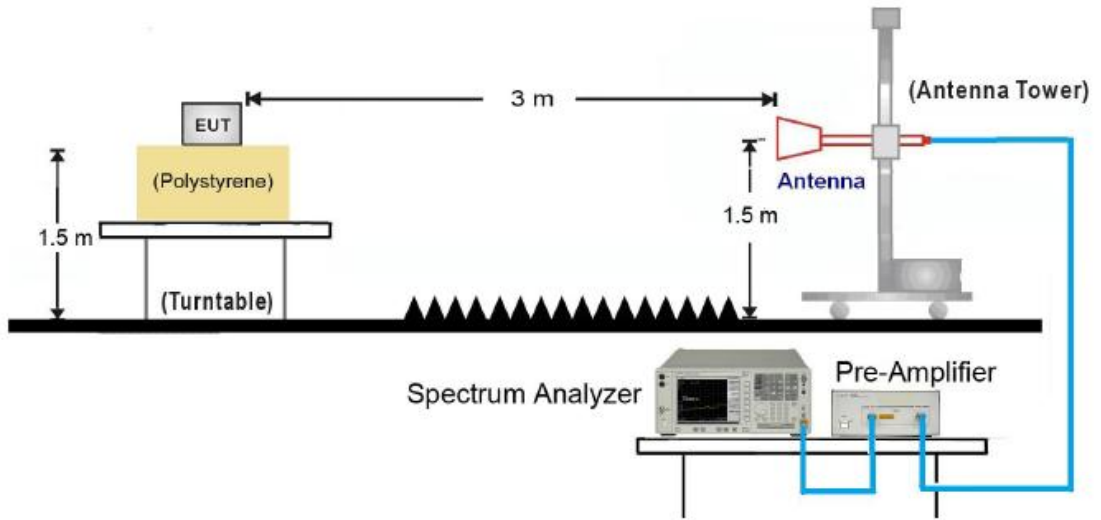

#### 6.7.4. Test Result

Product	Walkie Talkie	Temperature	25°C
Test Engineer	Max Wang	Relative Humidity	56%
Test Site	AC1	Test Date	2019/03/05

Frequency (MHz)	Ant. Pol. (H/V)	SG Reading (dBm)	Cable Loss (dB)	Substitute Antenna Gain (dBd)	ERP (dBm)	Limit (dBm)	Result
<b>Channel 01 (462.5625MHz)</b>							
1386.0	H	-33.8	0.6	7.9	-26.5	-13.0	Pass
3700.0	H	-59.5	0.9	12.7	-47.7	-13.0	Pass
1386.0	V	-38.2	0.6	7.9	-30.9	-13.0	Pass
3700.0	V	-60.9	0.9	12.7	-49.1	-13.0	Pass
<b>Channel 08 (467.5625MHz)</b>							
1402.0	H	-26.6	0.6	8.0	-19.2	-13.0	Pass
3740.0	H	-35.8	0.9	12.7	-24.0	-13.0	Pass
3274.0	V	-38.8	0.8	12.6	-27.0	-13.0	Pass
3740.0	V	-31.7	0.9	12.7	-19.9	-13.0	Pass
<b>Channel 22 (462.7250MHz)</b>							
1850.0	H	-43.2	0.8	10.4	-33.6	-13.0	Pass
3702.0	H	-62.2	0.9	12.7	-50.4	-13.0	Pass
1388.0	V	-43.9	0.6	7.9	-36.6	-13.0	Pass
3702.0	V	-43.9	0.9	12.7	-32.1	-13.0	Pass

#### Notes:

- Spurious emissions within 30-1000MHz were found more than 20dB below the limit, therefore no data appear in the report.
- ERP (dBm) = SG Reading (dBm) - Cable Loss (dB) + Substitute Antenna Gain (dBd).

## 7. CONCLUSION

The data collected relate only the item(s) tested and show that the device is in compliance with Part 95 of the FCC Rules.

\_\_\_\_\_ The End \_\_\_\_\_

## **APPENDIX A - TEST SETUP PHOTOGRAPH**

Refer to "1903RSU001-UT" file.

## **APPENDIX B - EUT PHOTOGRAPH**

Refer to "1903RSU001-UE" file.