

FCC RADIO TEST REPORT

FCC ID: 2ACVBKCD24T01

Product : 2.4G RF Module

Trade Name : N/A

Model Name : KCD24T01

Serial Model : N/A

Prepared for

SHENZHEN KECHUANGDA MICRO ELECTRONICS CO.,LTD

10F, Qinghua information Port A, North Highkeyuan
Road, Nanshan District, Shenzhen, China

Prepared by

Shenzhen STONE Testing Technology Co.,Ltd.

F/6, Bldg.12, Zhongxing Industrial City, Chuangye Rd., Nanshan District
Shenzhen P.R. China

TEST RESULT CERTIFICATION

Applicant's name SHENZHEN KECHUANGDA MICRO ELECTRONICS CO.,LTD
Address 10F, Qinghua information Port A, North Highkeyuan
 Road, Nanshan District, Shenzhen, China
Manufacture's Name..... SHENZHEN HUIZHONGDA ELECTRONICE CO., LTD
Address 5/F, Building B4, Yingtian Industry XiXiang Road BaoAn Distict
 ShenZhen,China

Product description

Product name 2.4G RF Module
Model and/or type reference KCD24T01

Serial Model : N/A

Standards FCC Part15.249

Test procedure ANSI C63.4-2003

This device described above has been tested by STT, and the test results show that the equipment under test (EUT) is in compliance with the FCC requirements. And it is applicable only to the tested sample identified in the report.

This report shall not be reproduced except in full, without the written approval of STT, this document may be altered or revised by STT, personal only, and shall be noted in the revision of the document.

Date of Test

Date (s) of performance of tests 15 Jul. 2014 ~05 Aug. 2014

Date of Issue..... 05 Aug. 2014

Test Result..... **Pass**

Testing Engineer : Eric Wang
 (Eric Wang)

Technical Manager : Jerry You
 (Jerry You)

Authorized Signatory : Jack Yu
 (Jack yu)

Table of Contents	Page
1 . SUMMARY OF TEST RESULTS	4
1.1 TEST FACILITY	5
1.2 MEASUREMENT UNCERTAINTY	5
2 . GENERAL INFORMATION	6
2.1 GENERAL DESCRIPTION OF EUT	6
2.2 DESCRIPTION OF TEST MODES	8
2.3 BLOCK DIGRAM SHOWING THE CONFIGURATION OF SYSTEM TESTED	9
2.4 DESCRIPTION OF SUPPORT UNITS(CONDUCTED MODE)	10
2.5 EQUIPMENTS LIST FOR ALL TEST ITEMS	11
3 . ANTENNA REQUIREMENT	12
3.1 STANDARD REQUIREMENT	12
3.2 EUT ANTENNA	12
3.3 CONDUCTED EMISSION MEASUREMENT	13
3.3.1 POWER LINE CONDUCTED EMISSION LIMITS	13
3.3.2 TEST PROCEDURE	14
3.3.3 DEVIATION FROM TEST STANDARD	14
3.3.4 TEST SETUP	14
3.2.5 TEST RESULT	15
3.4 RADIATED EMISSION MEASUREMENT	16
3.4.1 RADIATED EMISSION LIMITS	16
3.4.2 TEST PROCEDURE	17
3.4.3 DEVIATION FROM TEST STANDARD	17
3.4.4 TEST SETUP	18
3.4.5 TEST RESULTS (BELOW 30MHZ)	20
3.4.6 TEST RESULTS (BETWEEN 30 – 1000 MHZ)	21
3.4.7 TEST RESULTS (ABOVE 1000 MHZ)	23
3.4.8 TEST RESULTS (RESTRICTED BANDS REQUIREMENTS)	29
4 . BANDWIDTH TEST	33
4.1 TEST PROCEDURE	33
4.2 DEVIATION FROM STANDARD	33
4.3 TEST SETUP	33
4.4 TEST RESULTS	34
5 . EUT TEST PHOTO	37
APPENDIX-PHOTOGRAPHS OF EUT CONSTRUCTIONAL DETAILS	

1. SUMMARY OF TEST RESULTS

Test procedures according to the technical standards:

FCC Part15, Subpart C (15.249)			
Standard Section	Test Item	Judgment	Remark
15.207	Conducted Emission	N/A	
15.203	Antenna Requirement	Pass	
15.249	Radiated Spurious Emission	Pass	
15.205	Band Edge Emission	Pass	
15.249	Occupied Bandwidth	Pass	

NOTE:

(1) "N/A" denotes test is not applicable in this Test Report

1.1 TEST FACILITY

Shenzhen STONE Testing Technology Co.,Ltd.

Add. : F/1, Bldg.12, Zhongxing Industrial City, Chuangye Rd., Nanshan District
Shenzhen China

FCC Registration No.: 323508; IC Registration No.: 11043A

1.2 MEASUREMENT UNCERTAINTY

The reported uncertainty of measurement $y \pm U$, where expanded uncertainty U is based on a standard uncertainty multiplied by a coverage factor of $k=2$, providing a level of confidence of approximately **95 %**.

No.	Item	Uncertainty
1	Conducted Emission Test	$\pm 1.38\text{dB}$
2	RF power,conducted	$\pm 0.16\text{dB}$
3	Spurious emissions,conducted	$\pm 0.21\text{dB}$
4	All emissions,radiated(<1G)	$\pm 4.68\text{dB}$
5	All emissions,radiated(>1G)	$\pm 4.89\text{dB}$
6	Temperature	$\pm 0.5^{\circ}\text{C}$
7	Humidity	$\pm 2\%$

2. GENERAL INFORMATION

2.1 GENERAL DESCRIPTION OF EUT

Equipment	2.4G RF Module	
Trade Name	N/A	
Model Name	KCD24T01	
Serial Model	N/A	
Model Difference	All the models are the same circuit and RF module, except the model names.	
Product Description	The EUT is a 2.4G RF Module	
	Operation Frequency:	2402~2480MHz
	Modulation Type:	GFSK
	Antenna Designation:	Extension wire Antenna
	Antenna Gain(Peak)	0 dBi
	Field Strength	89.86 dBuv/m@3m(AVG)
	Based on the application, features, or specification exhibited in User's Manual, the EUT is considered as an ITE/Computing Device. More details of EUT technical specification, please refer to the User's Manual.	
Channel List	Please refer to the Note 2.	
Adapter	N/A	
Battery	DC 4.5V	

Note:

1. For a more detailed features description, please refer to the manufacturer's specifications or the User's Manual.

2.

Channel	Frequency (MHz)
01	2402
02	2440
03	2480

3.

Table for Filed Antenna

Ant	Brand	Model Name	Antenna Type	Connector	Gain (dBi)	NOTE
1	N/A	N/A	Integral Wire Antenna	N/A	0	Antenna

2.2 DESCRIPTION OF TEST MODES

To investigate the maximum EMI emission characteristics generated from EUT, the test system was pre-scanning tested based on the consideration of following EUT operation mode or test configuration mode which possibly have effect on EMI emission level. Each of these EUT operation mode(s) or test configuration mode(s) mentioned above was evaluated respectively.

Pretest Mode	Description
Mode 1	TX CH 01
Mode 2	TX CH 02
Mode 3	TX CH 03

For Conducted Emission	
Final Test Mode	Description
/	/

For Radiated Emission	
Final Test Mode	Description
Mode 1	TX CH 01
Mode 2	TX CH 02
Mode 3	TX CH 03

Note:

- (1) The measurements are performed at the highest, middle, lowest available channels.
- (2) The EUT use new battery.

2.3 BLOCK DIGRAM SHOWING THE CONFIGURATION OF SYSTEM TESTED

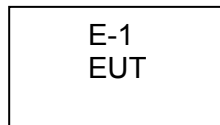

2.4 DESCRIPTION OF SUPPORT UNITS(CONDUCTED MODE)

The EUT has been tested as an independent unit together with other necessary accessories or support units. The following support units or accessories were used to form a representative test configuration during the tests.

Item	Equipment	Brand	Model/Type No.	Series No.	Note
E-1	2.4G RF Module	N/A	KCD24T01	N/A	EUT

Item	Shielded Type	Ferrite Core	Length	Note

Note:

- (1) The support equipment was authorized by Declaration of Confirmation.
- (2) For detachable type I/O cable should be specified the length in cm in 『Length』 column.

2.5 EQUIPMENTS LIST FOR ALL TEST ITEMS

Radiation Test equipment

Item	Kind of Equipment	Manufacturer	Type No.	Serial No.	Last calibration	Calibrated until	Calibration period
1	Spectrum Analyzer	Agilent	E4407B	MY45108040	2014.07.06	2015.07.05	1 year
2	Test Receiver	R&S	ESPI	101318	2014.06.07	2015.06.06	1 year
3	Bilog Antenna	TESEQ	CBL6111D	31216	2014.07.06	2015.07.05	1 year
4	50Ω Coaxial Switch	Anritsu	MP59B	6200264416	2014.06.07	2015.06.06	1 year
5	Spectrum Analyzer	ADVANTEST	R3132	150900201	2014.06.07	2015.06.06	1 year
6	Horn Antenna	EM	EM-AH-10180	2011071402	2014.07.06	2015.07.05	1 year
7	Horn Ant	Schwarzbeck	BBHA 9170	9170-181	2014.07.06	2015.07.05	1 year
8	Amplifier	EM	EM-30180	060538	2013.12.22	2014.12.21	1 year
9	Loop Antenna	ARA	PLA-1030/B	1029	2014.06.08	2015.06.07	1 year
10	Power Meter	R&S	NRVS	100696	2014.07.06	2015.07.05	1 year
11	Power Sensor	R&S	URV5-Z4	0395.1619.05	2014.07.06	2015.07.05	1 year

Conduction Test equipment

Item	Kind of Equipment	Manufacturer	Type No.	Serial No.	Last calibration	Calibrated until	Calibration period
1	Test Receiver	R&S	ESCI	101160	2014.06.06	2015.06.05	1 year
2	LISN	R&S	ENV216	101313	2014.06.06	2015.06.05	1 year
3	LISN	EMCO	3816/2	00042990	2014.06.06	2015.06.05	1 year
4	50Ω Coaxial Switch	Anritsu	MP59B	6200264417	2014.06.07	2015.06.06	1 year
5	Passive Voltage Probe	R&S	ESH2-Z3	100196	2014.06.07	2015.06.06	1 year
6	Absorbing clamp	R&S	MOS-21	100423	2014.06.08	2015.06.07	1 year

3. ANTENNA REQUIREMENT

3.1 STANDARD REQUIREMENT

15.203 requirement: For intentional device, according to 15.203: an intentional radiator shall be designed to ensure that no antenna other than that furnished by the responsible party shall be used with the device.

3.2 EUT ANTENNA

The EUT antenna is integral Antenna. It comply with the standard requirement.

3.3 CONDUCTED EMISSION MEASUREMENT

3.3.1 POWER LINE CONDUCTED EMISSION Limits (Frequency Range 150KHz-30MHz)

FREQUENCY (MHz)	Class A (dBuV)		Class B (dBuV)		Standard
	Quasi-peak	Average	Quasi-peak	Average	
0.15 -0.5			66 - 56 *	56 - 46 *	CISPR
0.50 -5.0			56.00	46.00	CISPR
5.0 -30.0			60.00	50.00	CISPR

0.15 -0.5			66 - 56 *	56 - 46 *	LP002.
0.50 -5.0			56.00	46.00	LP002.
5.0 -30.0			60.00	50.00	LP002.

Note:

- (1) The tighter limit applies at the band edges.
- (2) The limit of " * " marked band means the limitation decreases linearly with the logarithm of the frequency in the range.

The following table is the setting of the receiver

Receiver Parameters	Setting
Attenuation	10 dB
Start Frequency	0.15 MHz
Stop Frequency	30 MHz
IF Bandwidth	9 kHz

3.3.2 TEST PROCEDURE

- The EUT was placed 0.8 meters from the horizontal ground plane with EUT being connected to the power mains through a line impedance stabilization network (LISN). All other support equipments powered from additional LISN(s). The LISN provide 50 Ohm/ 50uH of coupling impedance for the measuring instrument.
- Interconnecting cables that hang closer than 40 cm to the ground plane shall be folded back and forth in the center forming a bundle 30 to 40 cm long.
- I/O cables that are not connected to a peripheral shall be bundled in the center. The end of the cable may be terminated, if required, using the correct terminating impedance. The overall length shall not exceed 1 m.
- LISN at least 80 cm from nearest part of EUT chassis.
- For the actual test configuration, please refer to the related Item –EUT Test Photos.

3.3.3 DEVIATION FROM TEST STANDARD

No deviation

3.3.4 TEST SETUP

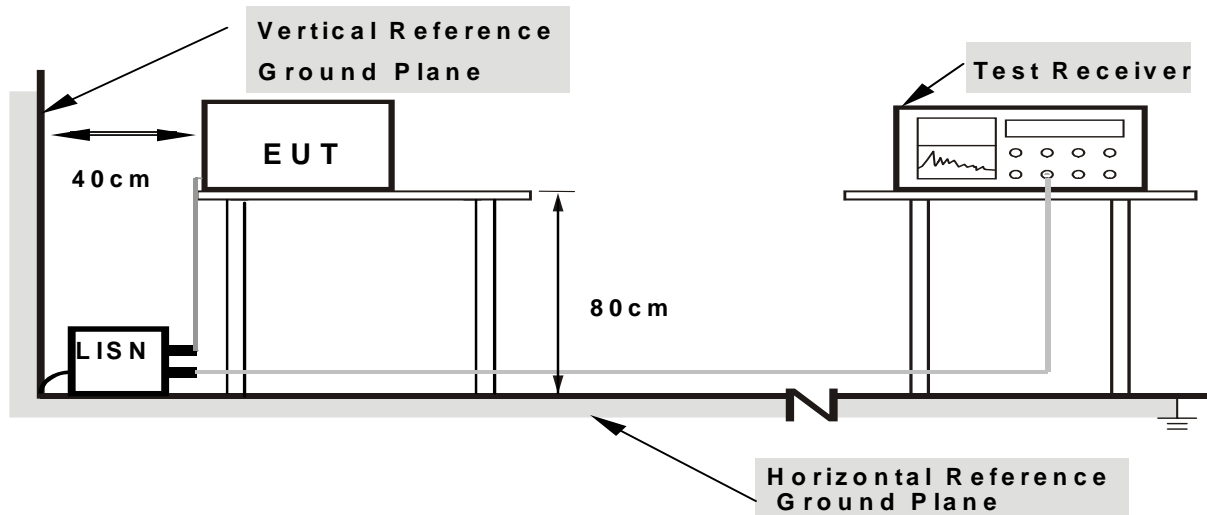

Note: 1. Support units were connected to second LISN.

2. Both of LISNs (AMN) are 80 cm from EUT and at least 80 cm from other units and other metal planes

3.2.5 TEST RESULT

EUT :	2.4G RF Module	Model Name. :	KCD24T01
Temperature :	20 °C	Relative Humidity :	48%
Pressure :	1010 hPa	Test Voltage :	N/A
Test Mode :	N/A		

Note: due to this EUT is powered by the battery only, this test item is not applicable.

3.4 RADIATED EMISSION MEASUREMENT

3.4.1 Radiated Emission Limits (FCC 15.209)

Frequencies (MHz)	Field Strength (micorvolts/meter)	Measurement Distance (meters)
0.009~0.490	2400/F(KHz)	300
0.490~1.705	24000/F(KHz)	30
1.705~30.0	30	30
30~88	100	3
88~216	150	3
216~960	200	3
Above 960	500	3

Note:

- (1) The tighter limit applies at the band edges.
- (2) Emission level (dBUV/m)=20log Emission level (uV/m).

LIMITS OF RADIATED EMISSION MEASUREMENT (FCC 15.249)

Frequency of Emission (MHz)	Field Strength of fundamental ((millivolts /meter)	Field Strength of Harmonics (microvolts/meter)
2400 - 2483.5	50	500

Notes:

- (1) Emissions radiated outside of the specified frequency bands, except for harmonics, shall be attenuated by at least 50 dB below the level of the fundamental or to the general radiated emission limits in Section 15.209, whichever is the lesser attenuation.

Spectrum Parameter	Setting
Attenuation	Auto
Start Frequency	1000 MHz
Stop Frequency	10th carrier harmonic
RB / VB (emission in restricted band)	1MHz / 1MHz for Peak

Receiver Parameter	Setting
Attenuation	Auto
Start ~ Stop Frequency	9kHz~150kHz / RB 200Hz for QP
Start ~ Stop Frequency	150kHz~30MHz / RB 9kHz for QP
Start ~ Stop Frequency	30MHz~1000MHz / RB 120kHz for QP

3.4.2 TEST PROCEDURE

- a. The measuring distance of at 3 m shall be used for measurements at frequency up to 1GHz. For frequencies above 1GHz, any suitable measuring distance may be used.
- b. The EUT was placed on the top of a rotating table 0.8 meters above the ground at a 3m meter open area test site. The table was rotated 360 degrees to determine the position of the highest radiation.
- c. The height of the equipment or of the substitution antenna shall be 0.8 m; the height of the test antenna shall vary between 1 m to 4 m.
- d. The initial step in collecting conducted emission data is a spectrum analyzer peak detector mode pre-scanning the measurement frequency range. Significant peaks are then marked and then Quasi Peak detector mode re-measured.
- e. If the Peak Mode measured value compliance with and lower than Quasi Peak Mode Limit, the EUT shall be deemed to meet QP Limits and then no additional QP Mode measurement performed.
- f. For the actual test configuration, please refer to the related Item –EUT Test Photos.

Note:

Both horizontal and vertical antenna polarities were tested and performed pretest to three orthogonal axis. The worst case emissions were reported

3.4.3 DEVIATION FROM TEST STANDARD

No deviation

3.4.4 TEST SETUP

(A) Radiated Emission Test-Up Frequency Below 30MHz

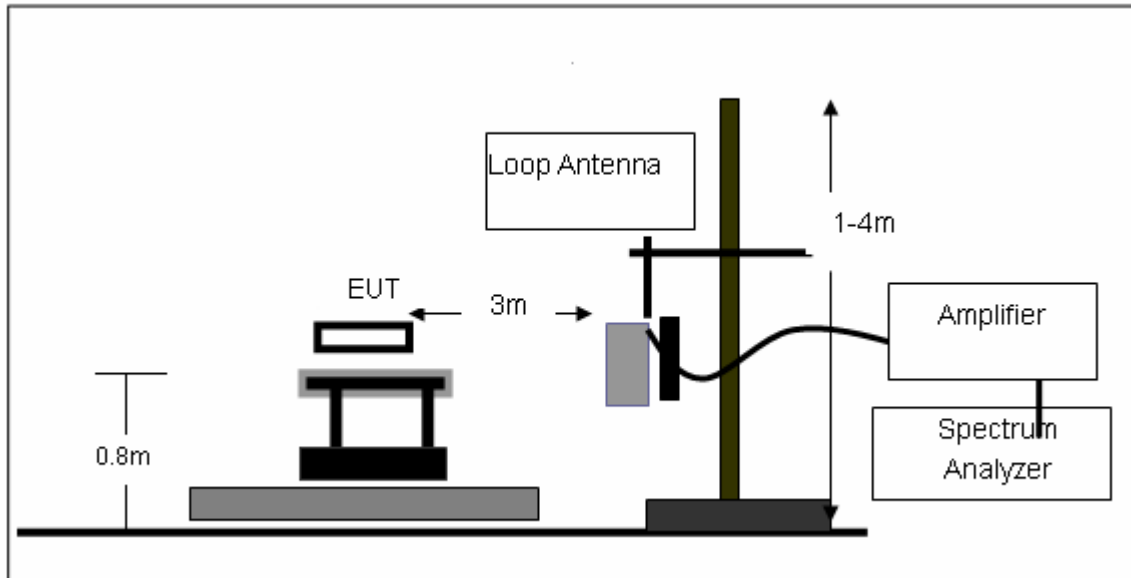

(B) Radiated Emission Test-Up Frequency 30MHz~1GHz

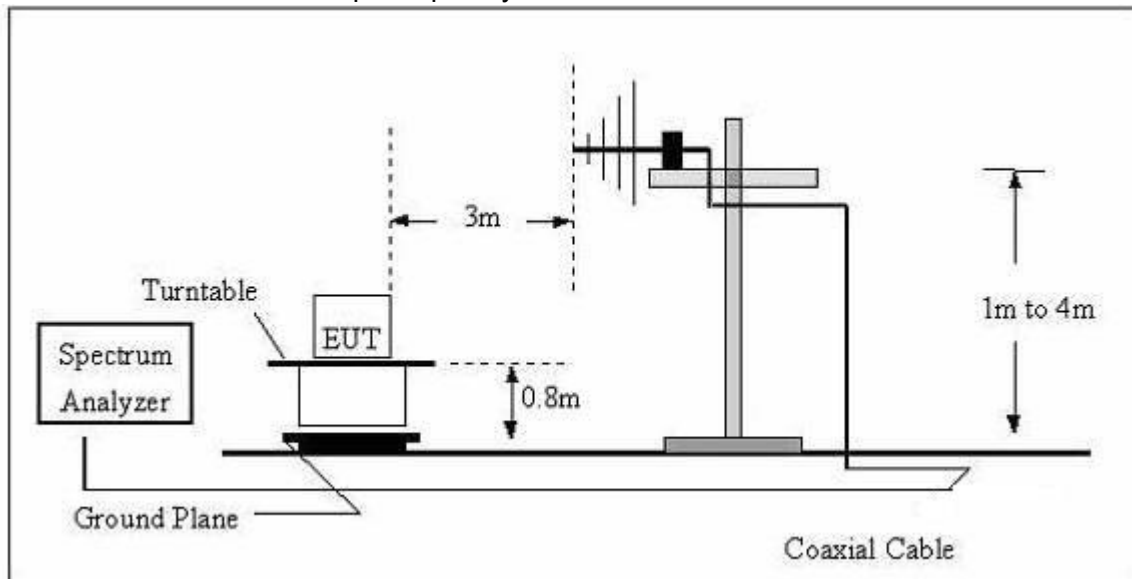

(C) Radiated Emission Test-Setup Frequency Above 1GHz

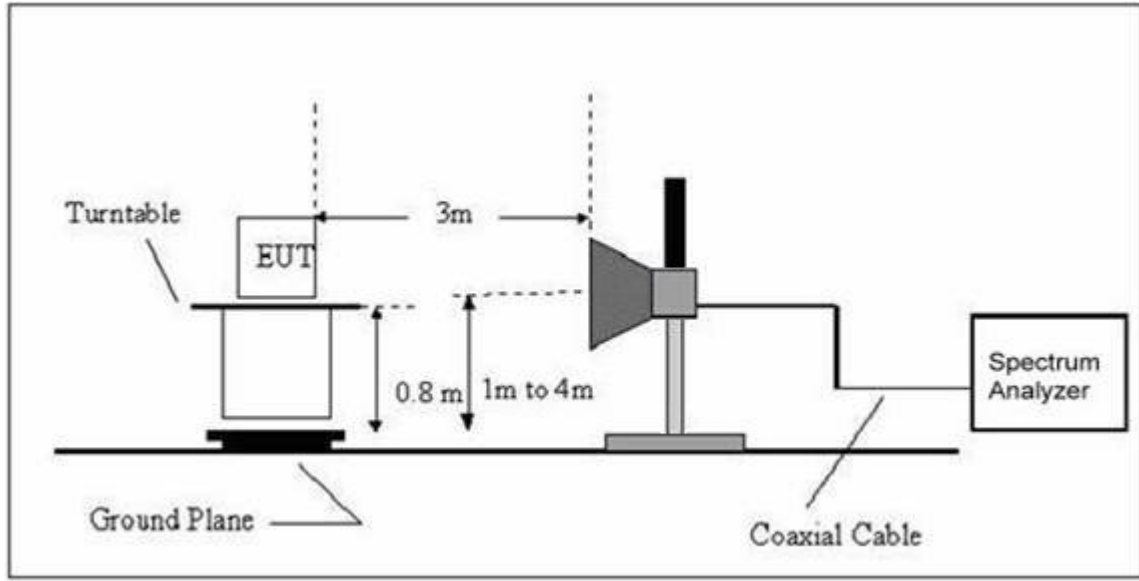

3.4.5 TEST RESULTS (BELOW 30MHz)

EUT :	2.4G RF Module	Model Name. :	KCD24T01
Temperature :	20 °C	Relative Humidity :	48%
Pressure :	1010 hPa	Test Voltage :	DC 4.5V
Test Mode :	TX	Polarization :	--

Freq.	Reading	Limit	Margin	State
(MHz)	(dBuV/m)	(dBuV/m)	(dB)	P/F
--	--	--	--	PASS
--	--	--	--	PASS

NOTE:

The amplitude of spurious emissions which are attenuated by more than 20dB below the permissible value has no need to be reported.

Distance extrapolation factor = $20 \log (\text{specific distance}/\text{test distance})$ (dB);

Limit line = specific limits(dBuv) + distance extrapolation factor.

3.4.6 TEST RESULTS (BETWEEN 30 – 1000 MHZ)

EUT :	2.4G RF Module	Model Name :	KCD24T01
Temperature :	20 °C	Relative Humidity :	48%
Pressure :	1010 hPa	Test Voltage :	DC 4.5V
Test Mode :	TX	Polarization :	Horizontal

Frequency (MHz)	Meter Reading (dBμV)	Factor (dB)	Emission Level (dBμV/m)	Limits (dBμV/m)	Margin (dB)	Detector Type
71.71	36.04	-20.77	15.27	40.00	-24.73	Peak
143.49	35.84	-18.12	17.72	43.50	-25.78	Peak

Remark:
 Factor = Antenna Factor + Cable Loss – Pre-amplifier.

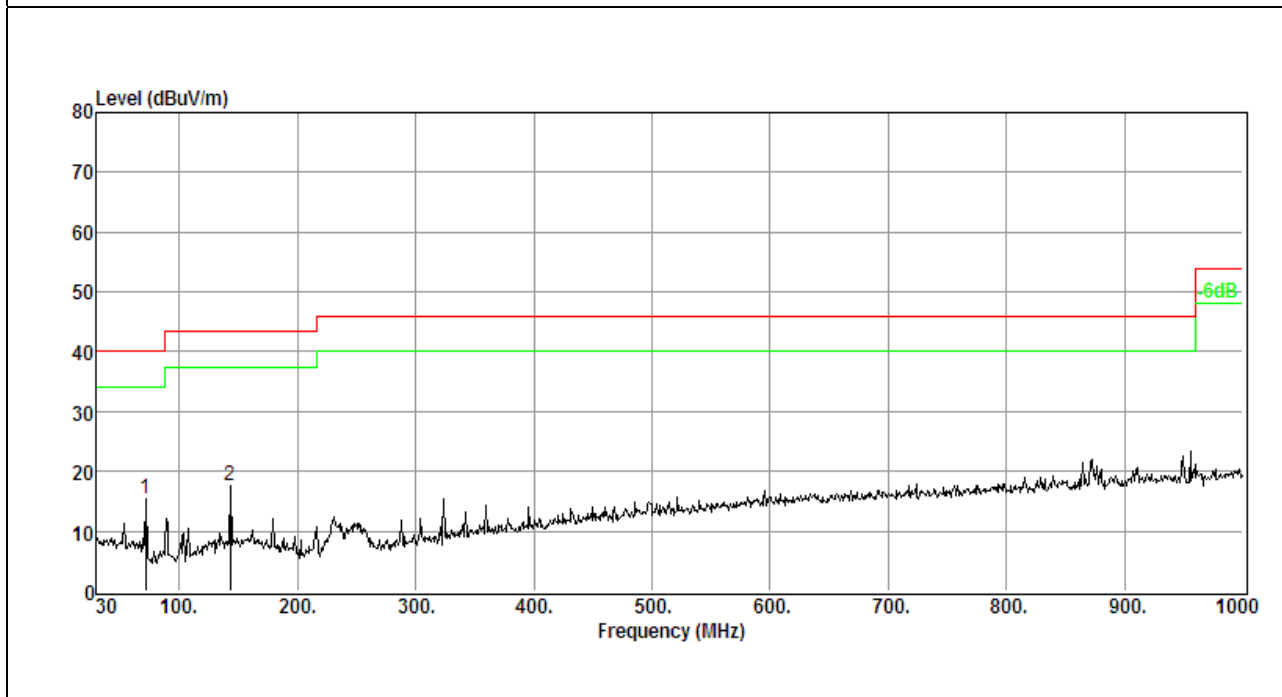

EUT :	2.4G RF Module	Model Name :	KCD24T01
Temperature :	20 °C	Relative Humidity :	48%
Pressure :	1010 hPa	Test Voltage :	DC 4.5V
Test Mode :	TX	Polarization :	Vertical

Frequency (MHz)	Meter Reading (dBμV)	Factor (dB)	Emission Level (dBμV/m)	Limits (dBμV/m)	Margin (dB)	Detector Type
58.13	34.80	-18.62	16.18	40.00	-23.82	Peak
143.49	36.97	-18.12	18.85	43.50	-24.65	Peak
179.38	36.72	-19.15	17.57	43.50	-25.93	Peak

Remark:
 Factor = Antenna Factor + Cable Loss – Pre-amplifier.

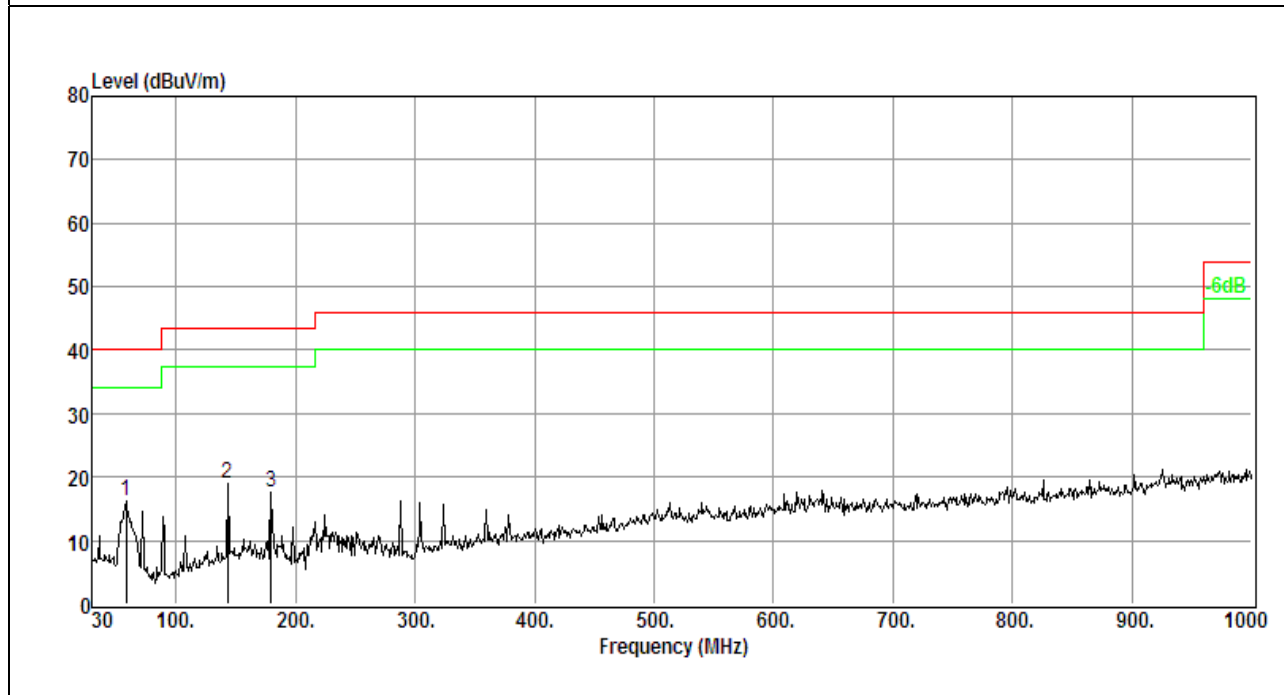

3.4.7 TEST RESULTS (ABOVE 1000 MHZ)

EUT :	2.4G RF Module	Model Name :	KCD24T01
Temperature :	20 °C	Relative Humidity :	48%
Pressure :	1010 hPa	Test Voltage :	DC 4.5V
Test Mode :	TX /2402MHz	Polarization :	Horizontal

Frequency (MHz)	Meter Reading (dBµV)	Factor (dB)	Emission Level (dBµV/m)	Limits (dBµV/m)	Margin (dB)	Detector Type
1253.74	53.24	-3.83	49.41	74	-24.59	peak
1253.74	43.25	-3.83	39.42	54	-14.58	AVG
2402.18	97.16	-0.69	96.47	114.0 0	-17.53	peak
2402.18	87.57	-0.69	86.88	94	-7.12	AVG
4804.43	41.25	10.4	51.65	74	-22.35	peak
4804.43	35.15	10.4	45.55	54	-8.45	AVG
7212.6	42.15	12.39	54.54	74	-19.46	peak
7212.6	31.25	12.39	43.64	54	-10.36	AVG

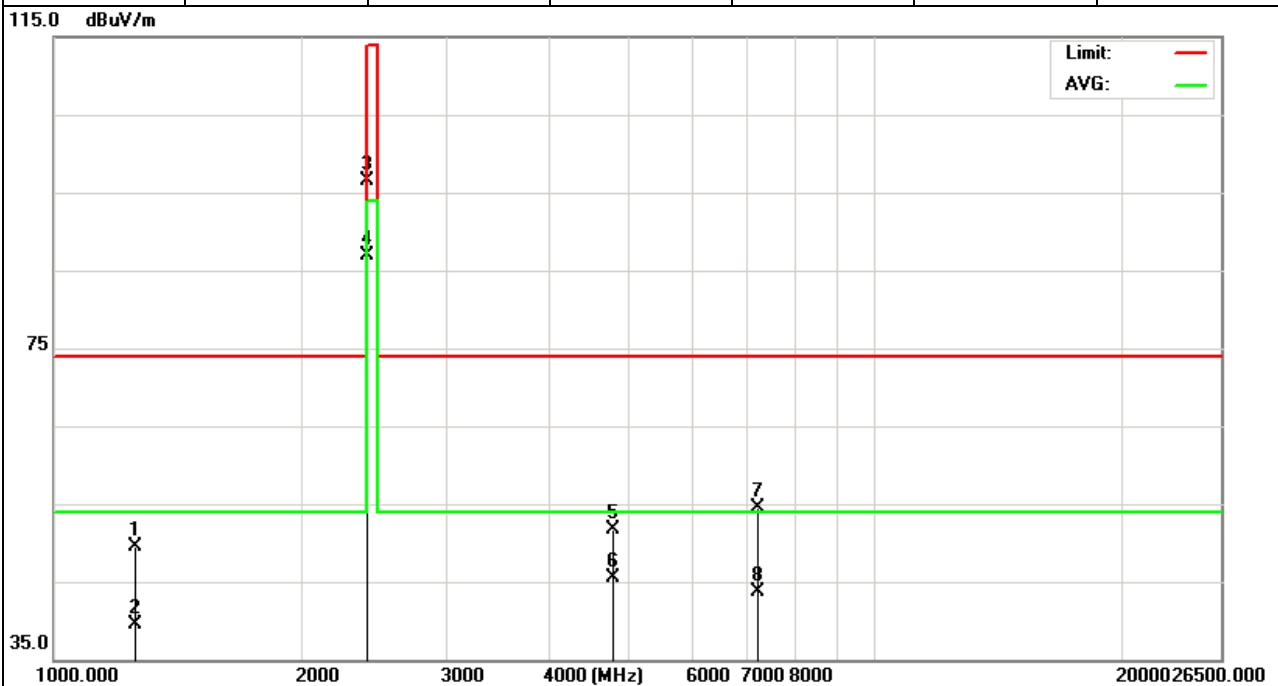

Remark:
 Factor = Antenna Factor + Cable Loss – Pre-amplifier.

EUT :	2.4G RF Module	Model Name :	KCD24T01
Temperature :	20 °C	Relative Humidity :	48%
Pressure :	1010 hPa	Test Voltage :	DC 4.5V
Test Mode :	TX /2402MHz	Polarization :	Vertical

Frequency (MHz)	Meter Reading (dBµV)	Factor (dB)	Emission Level (dBµV/m)	Limits (dBµV/m)	Margin (dB)	Detector Type
1452.25	51.32	-3.61	47.71	74	-26.29	peak
1452.25	40.35	-3.61	36.74	54	-17.26	AVG
2402.26	97.15	-0.69	96.46	114.0 0	-17.54	peak
2402.26	86.57	-0.69	85.88	94	-8.12	AVG
4804.52	46.22	10.4	56.62	74	-17.38	peak
4804.52	35.15	10.4	45.55	54	-8.45	AVG
7212.52	42.15	12.39	54.54	74	-19.46	peak
7212.52	33.65	12.39	46.04	54	-7.96	AVG

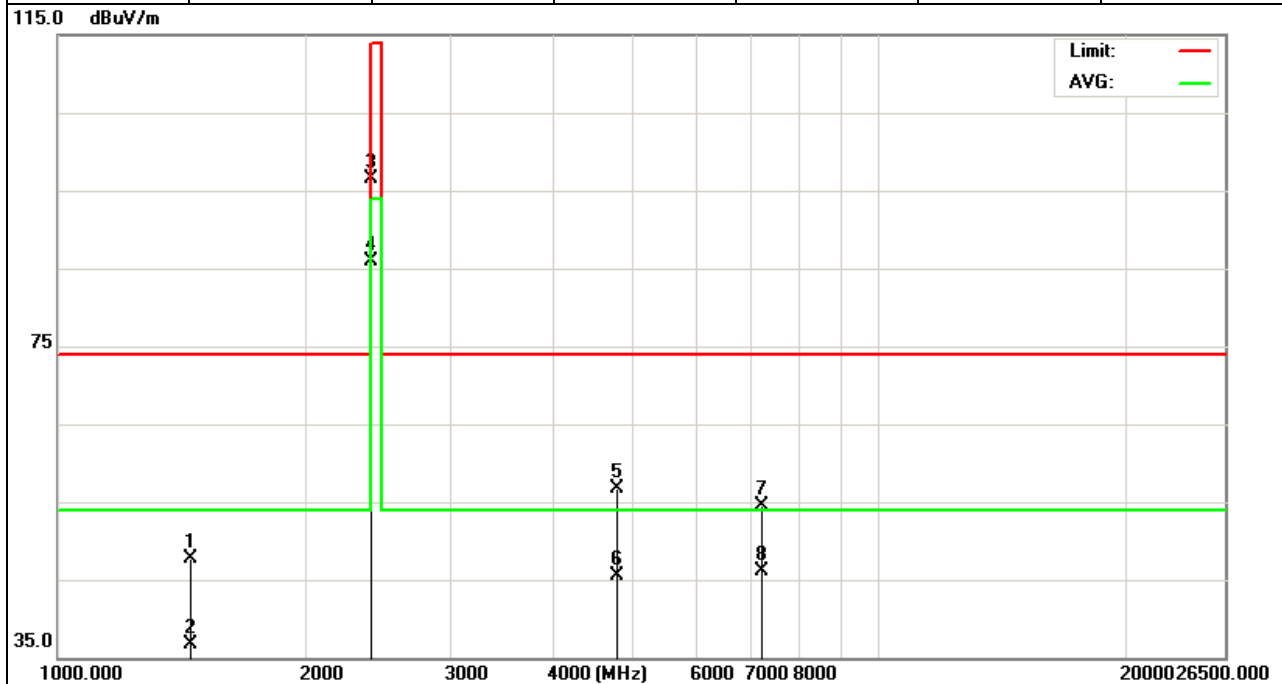

Remark:
 Factor = Antenna Factor + Cable Loss – Pre-amplifier.

EUT :	2.4G RF Module	Model Name :	KCD24T01
Temperature :	20 °C	Relative Humidity :	48%
Pressure :	1010 hPa	Test Voltage :	DC 4.5V
Test Mode :	TX /2440MHz	Polarization :	Horizontal

Frequency (MHz)	Meter Reading (dBµV)	Factor (dB)	Emission Level (dBµV/m)	Limits (dBµV/m)	Margin (dB)	Detector Type
1414.15	50.32	-3.86	46.46	74	-27.54	peak
1414.15	43.52	-3.86	39.66	54	-14.34	AVG
2440.02	99.68	-0.64	99.04	114.0 0	-14.96	peak
2440.05	88.32	-0.64	87.68	94	-6.32	AVG
4882.35	45.62	10.36	55.98	74	-18.02	peak
4882.35	33.65	10.36	44.01	54	-9.99	AVG
7323.65	41.25	12.77	54.02	74	-19.98	peak
7323.65	31.28	12.77	44.05	54	-9.95	AVG

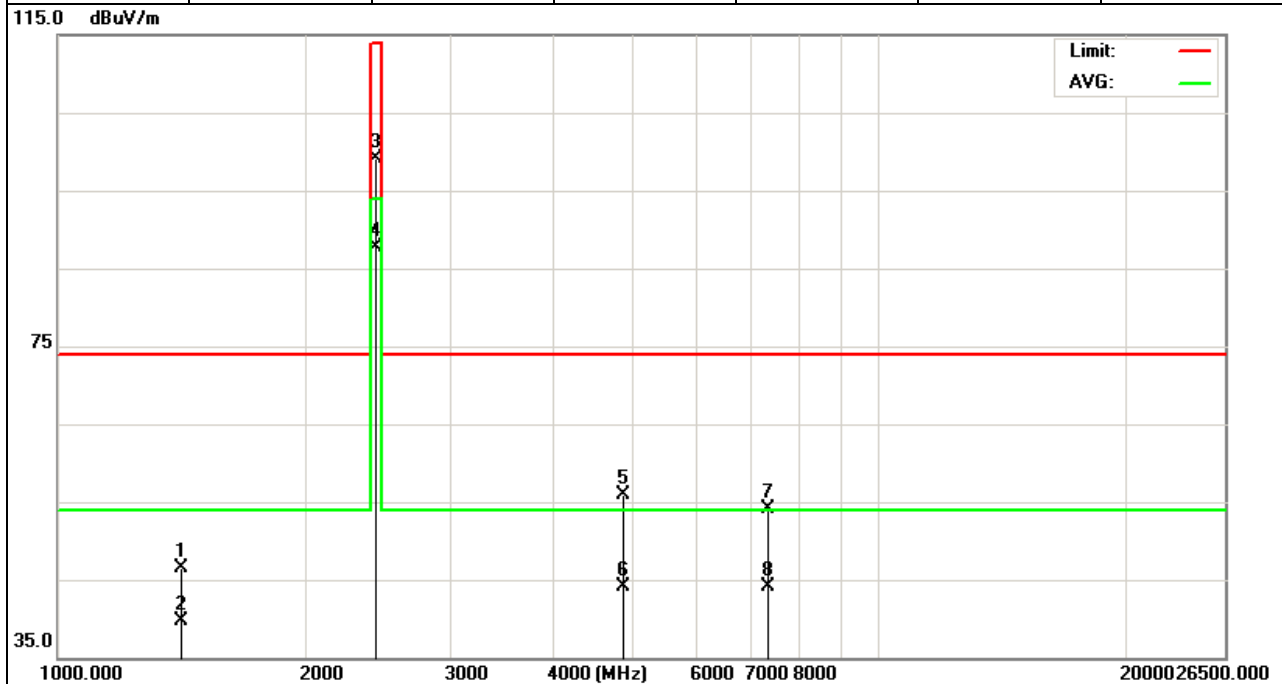

Remark:
 Factor = Antenna Factor + Cable Loss – Pre-amplifier.

EUT :	2.4G RF Module	Model Name :	KCD24T01
Temperature :	20 °C	Relative Humidity :	48%
Pressure :	1010 hPa	Test Voltage :	DC 4.5V
Test Mode :	TX /2440MHz	Polarization :	Vertical

Frequency (MHz)	Meter Reading (dBµV)	Factor (dB)	Emission Level (dBµV/m)	Limits (dBµV/m)	Margin (dB)	Detector Type
1762.35	56.35	-2.5	53.85	74	-20.15	peak
1762.35	47.15	-2.5	44.65	54	-9.35	AVG
2440.25	89.35	-0.64	88.71	94	-5.29	AVG
2440.35	98.62	-0.64	97.98	114.00	-16.02	peak
4882.13	41.94	10.36	52.3	74	-21.7	peak
4882.13	35.65	10.36	46.01	54	-7.99	AVG
7323.52	41.57	12.77	54.34	74	-19.66	peak
7323.52	33.35	12.77	46.12	54	-7.88	AVG

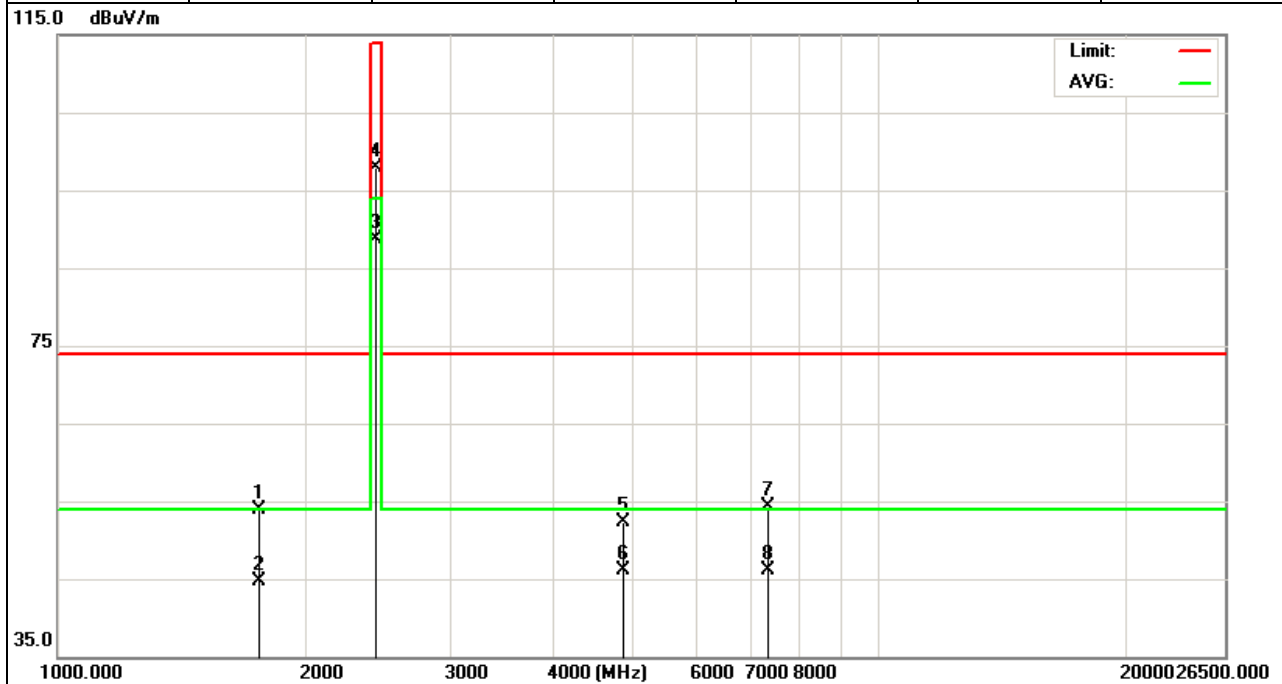

Remark:
 Factor = Antenna Factor + Cable Loss – Pre-amplifier.

EUT :	2.4G RF Module	Model Name :	KCD24T01
Temperature :	20 °C	Relative Humidity :	48%
Pressure :	1010 hPa	Test Voltage :	DC 4.5V
Test Mode :	TX /2480MHz	Polarization :	Horizontal

Frequency (MHz)	Meter Reading (dBµV)	Factor (dB)	Emission Level (dBµV/m)	Limits (dBµV/m)	Margin (dB)	Detector Type
1754.16	52.13	-2.54	49.59	74	-24.41	peak
1754.16	40.98	-2.54	38.44	54	-15.56	AVG
2480.32	102.35	-0.49	101.86	114.00	-12.14	peak
2480.32	90.35	-0.49	89.86	94	-4.14	AVG
4956.64	41.35	10.47	51.82	74	-22.18	peak
4956.64	33.35	10.47	43.82	54	-10.18	AVG
7434.96	40.68	13.08	53.76	74	-20.24	peak
7434.96	32.65	13.08	45.73	54	-8.27	AVG

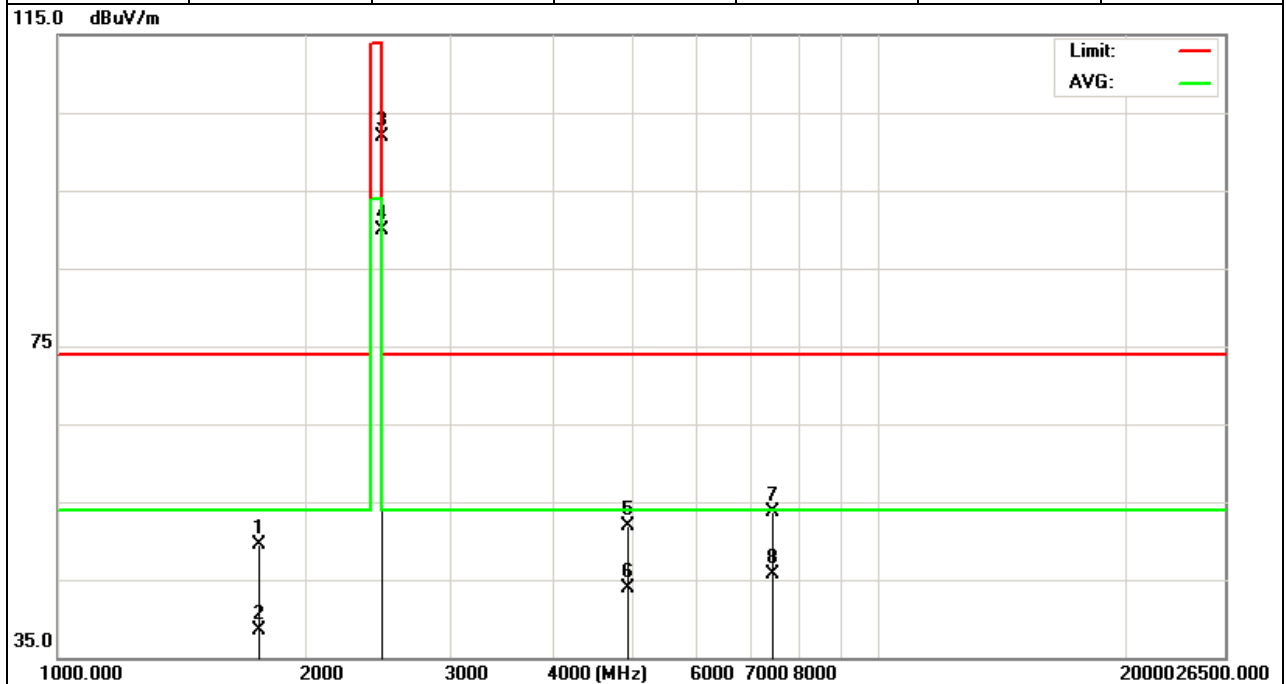

Remark:
 Factor = Antenna Factor + Cable Loss – Pre-amplifier.

EUT :	2.4G RF Module	Model Name :	KCD24T01
Temperature :	20 °C	Relative Humidity :	48%
Pressure :	1010 hPa	Test Voltage :	DC 4.5V
Test Mode :	TX /2480MHz	Polarization :	Vertical

Frequency (MHz)	Meter Reading (dBµV)	Factor (dB)	Emission Level (dBµV/m)	Limits (dBµV/m)	Margin (dB)	Detector Type
1754.16	52.31	-2.54	49.77	74	-24.23	peak
1754.16	43.66	-2.54	41.12	54	-12.88	AVG
2480.32	99.67	-0.49	99.18	114.00	-14.82	peak
2480.32	86.74	-0.49	86.25	94	-7.75	AVG
4956.64	45.62	10.47	56.09	74	-17.91	peak
4956.64	37.62	10.47	48.09	54	-5.91	AVG
7434.96	42.13	13.08	55.21	74	-18.79	peak
7434.96	33.35	13.08	46.43	54	-7.57	AVG

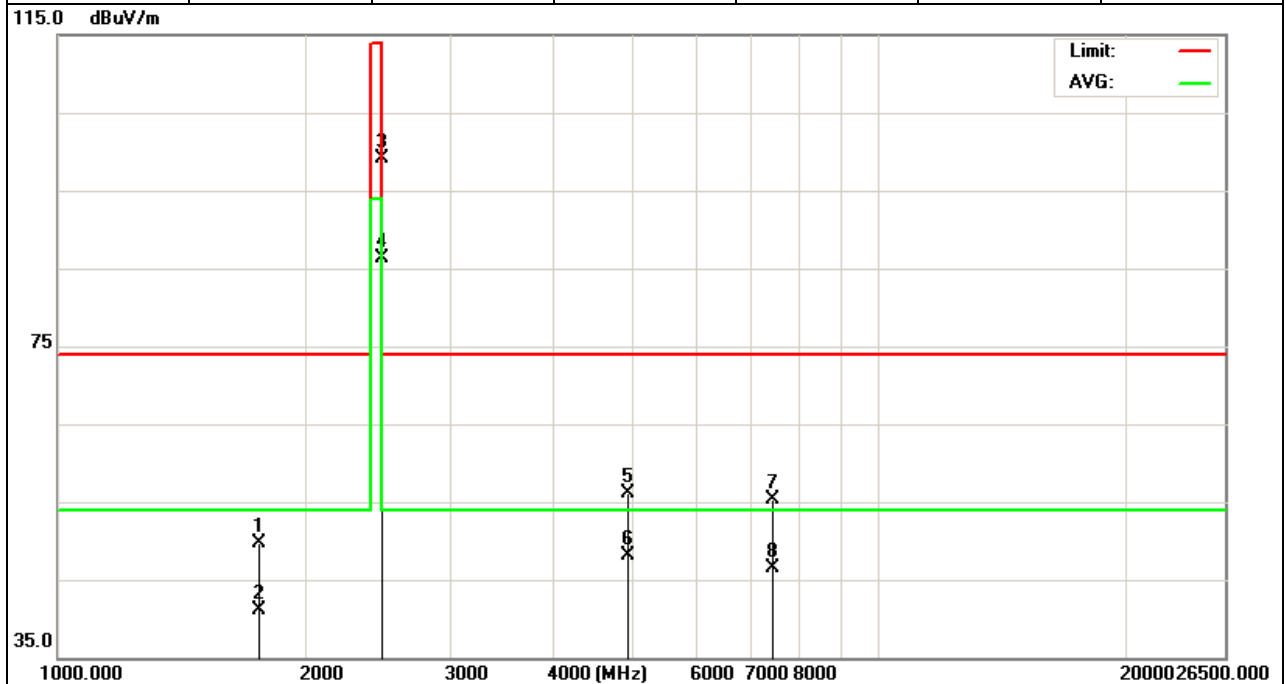

Remark:
 Factor = Antenna Factor + Cable Loss – Pre-amplifier.

3.4.8 TEST RESULTS (RESTRICTED BANDS REQUIREMENTS)

EUT :	2.4G RF Module	Model Name :	KCD24T01
Temperature :	20 °C	Relative Humidity :	48%
Pressure :	1010 hPa	Test Voltage :	DC 4.5V
Test Mode :	TX /2402MHz	Polarization :	Horizontal

Frequency (MHz)	Meter Reading (dBμV)	Factor (dB)	Emission Level (dBμV/m)	Limits (dBμV/m)	Margin (dB)	Detector Type
2400	59.96	-13.06	46.9	74	-27.1	peak

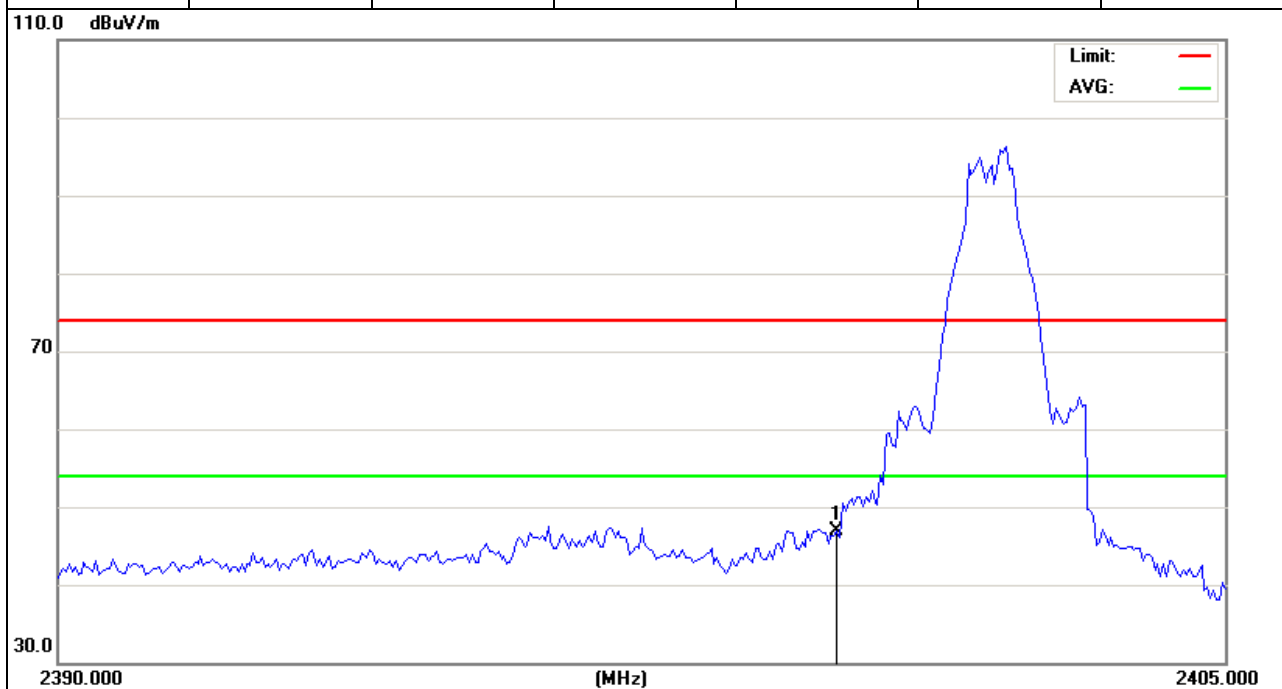

Remark:
Factor = Antenna Factor + Cable Loss – Pre-amplifier.

EUT :	2.4G RF Module	Model Name :	KCD24T01
Temperature :	20 °C	Relative Humidity :	48%
Pressure :	1010 hPa	Test Voltage :	DC 4.5V
Test Mode :	TX /2402MHz	Polarization :	Vertical

Frequency (MHz)	Meter Reading (dBµV)	Factor (dB)	Emission Level (dBµV/m)	Limits (dBµV/m)	Margin (dB)	Detector Type
2400	68.36	-13.06	55.3	74	-18.7	peak
2400	51.86	-13.06	38.8	54	-15.2	Avg

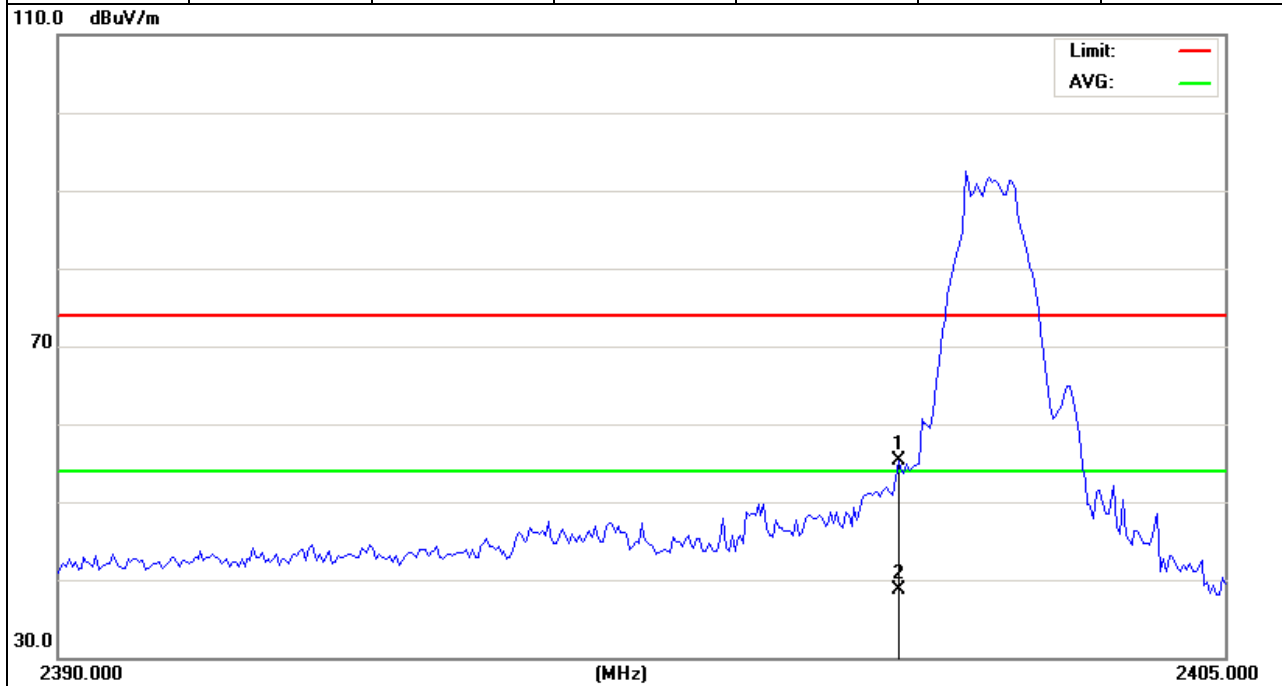

Remark:
 Factor = Antenna Factor + Cable Loss – Pre-amplifier.

EUT :	2.4G RF Module	Model Name :	KCD24T01
Temperature :	20 °C	Relative Humidity :	48%
Pressure :	1010 hPa	Test Voltage :	DC 4.5V
Test Mode :	TX /2480MHz	Polarization :	Horizontal

Frequency (MHz)	Meter Reading (dBµV)	Factor (dB)	Emission Level (dBµV/m)	Limits (dBµV/m)	Margin (dB)	Detector Type
2483.5	62.08	-12.78	49.3	74	-24.7	peak

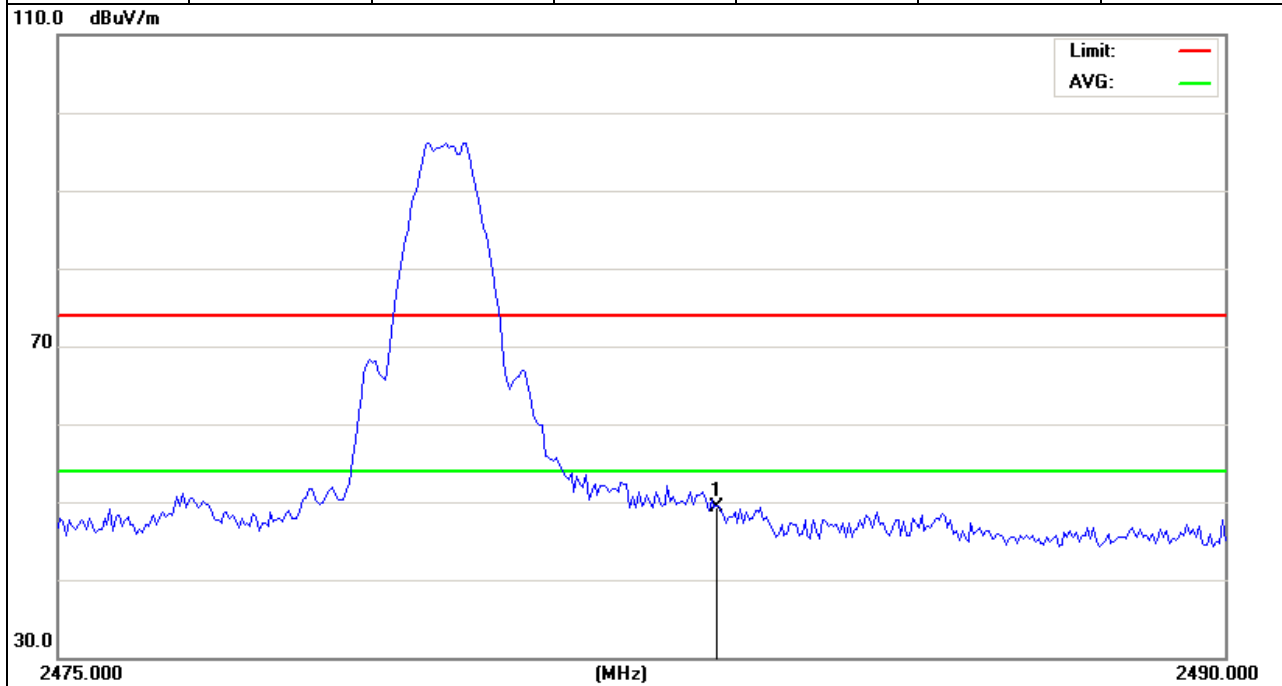

Remark:
 Factor = Antenna Factor + Cable Loss – Pre-amplifier.

EUT :	2.4G RF Module	Model Name :	KCD24T01
Temperature :	20 °C	Relative Humidity :	48%
Pressure :	1010 hPa	Test Voltage :	DC 4.5V
Test Mode :	TX /2480MHz	Polarization :	Vertical

Frequency (MHz)	Meter Reading (dBµV)	Factor (dB)	Emission Level (dBµV/m)	Limits (dBµV/m)	Margin (dB)	Detector Type
2483.5	57.18	-12.78	44.4	74	-29.6	peak

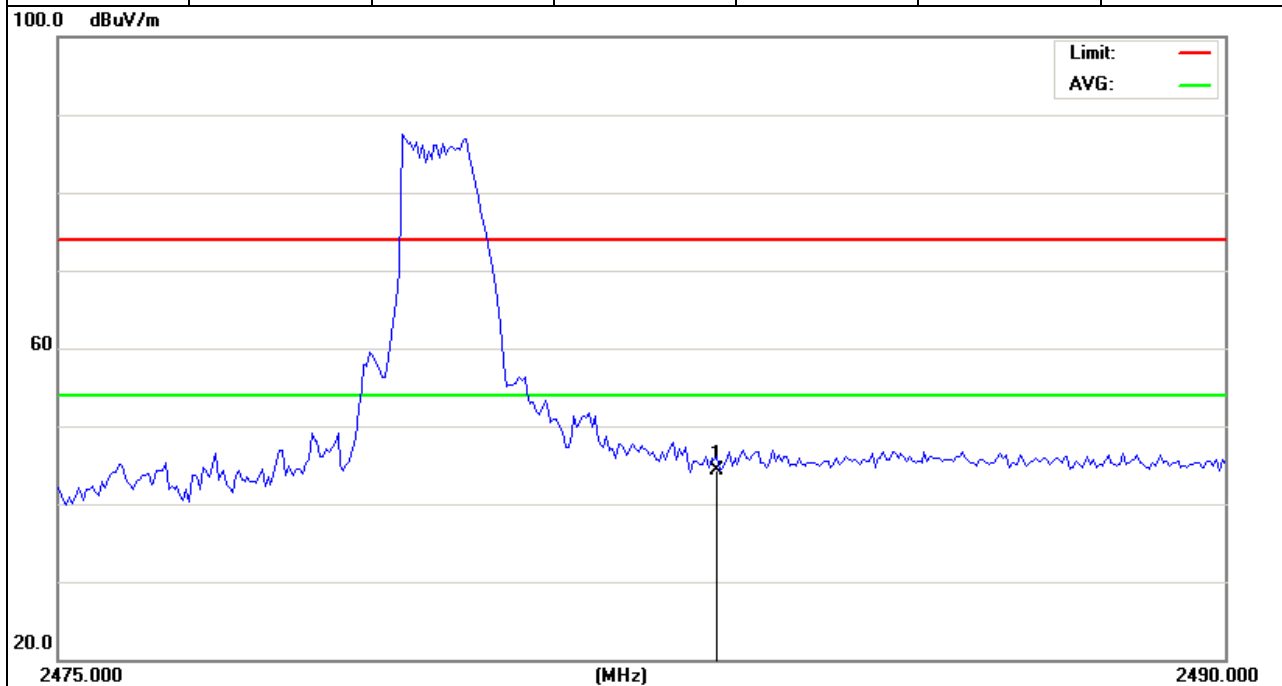

Remark:
 Factor = Antenna Factor + Cable Loss – Pre-amplifier.

4. BANDWIDTH TEST

4.1 TEST PROCEDURE

- a. The EUT was directly connected to the spectrum analyzer and antenna output port as show in the block diagram below,
- b. Spectrum Setting : RBW= 100KHz, VBW \geq RBW, Sweep time = Auto.

4.2 DEVIATION FROM STANDARD

No deviation.

4.3 TEST SETUP



4.4 TEST RESULTS

EUT :	2.4G RF Module	Model Name :	KCD24T01
Temperature :	26 °C	Relative Humidity :	53%
Pressure :	1020 hPa	Test Power :	DC 4.5V
Test Mode :	TX CH 01/02/03		

Test Channel	Frequency (MHz)	20 dB Bandwidth (kHz)
CH01	2402	880.038
CH02	2440	894.629
CH03	2480	901.092

The Lowest Channel:2402MHz

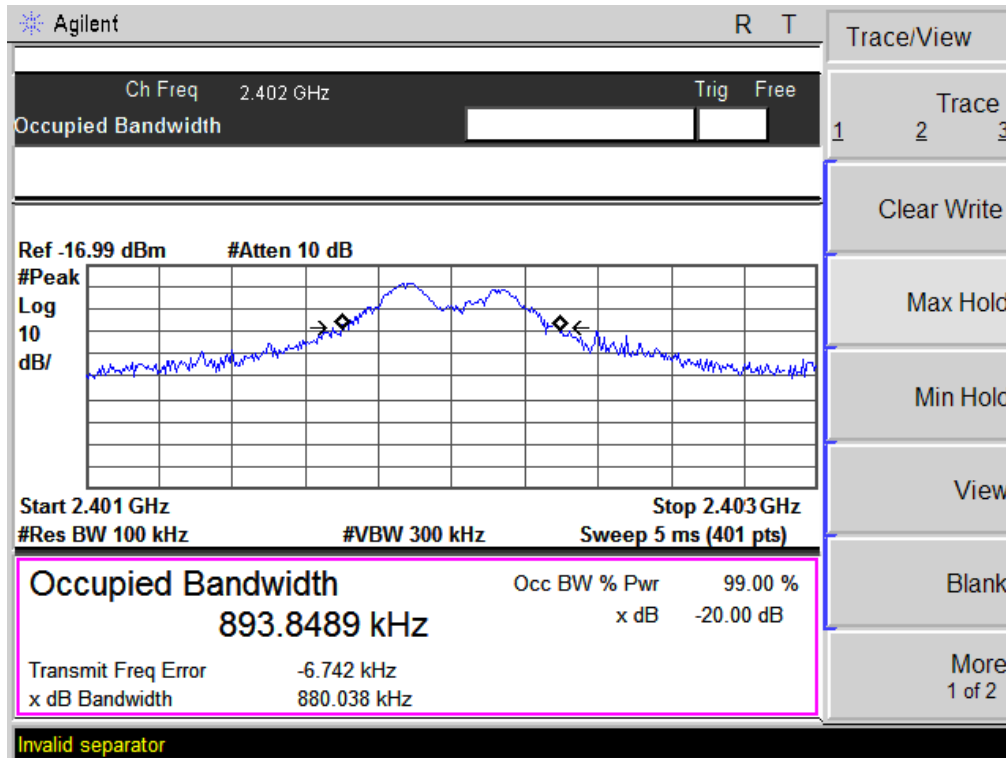

The Middle Channel: 2440MHz

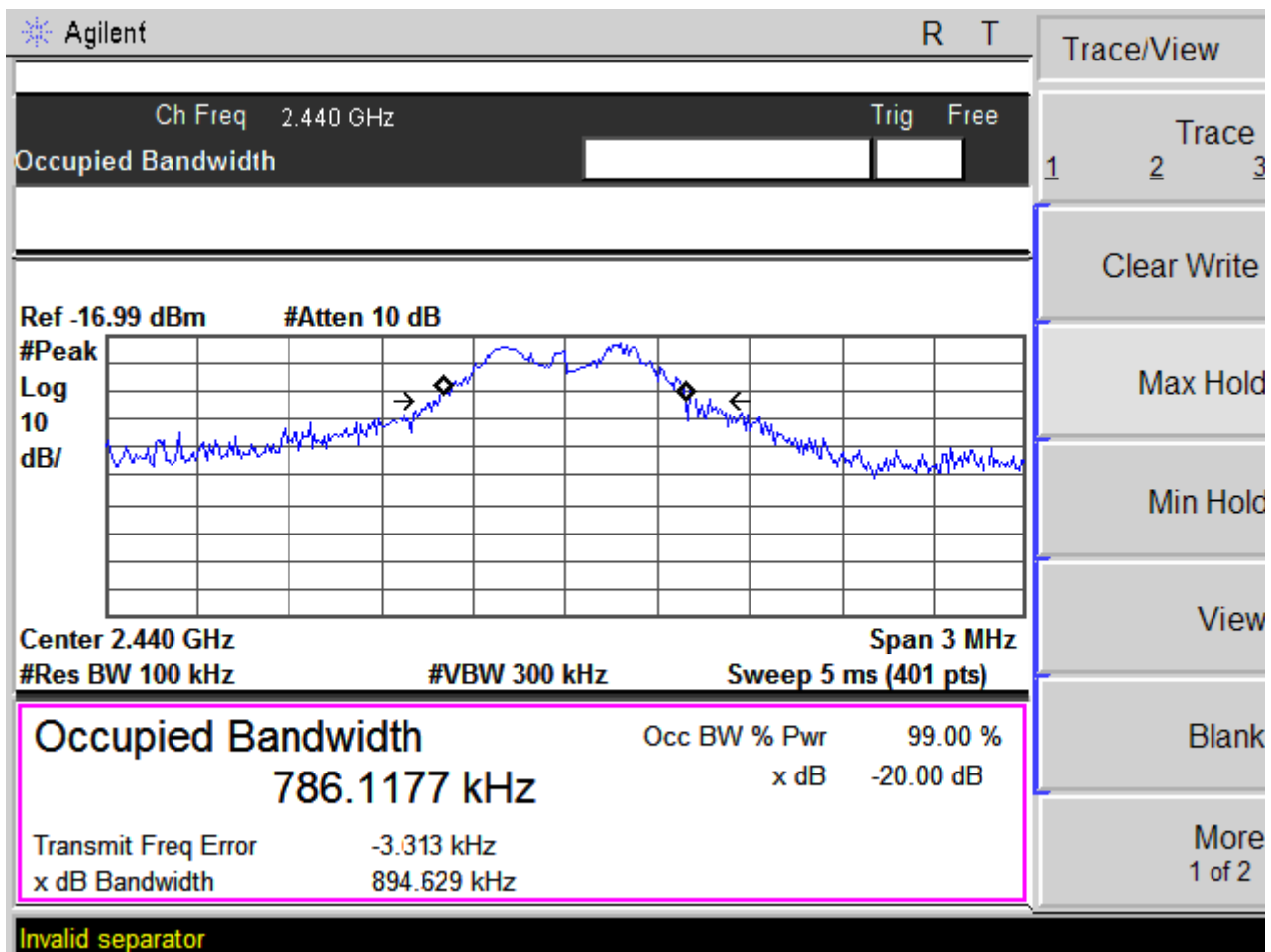

The High Channel:2480MHz

Agilent R T

Ch Freq 2.480 GHz Trig Free

Occupied Bandwidth

Ref 0 dBm #Atten 10 dB

#Peak

Log

10

dB/

Center 2.480 GHz #VBW 300kHz Span 3 MHz

#Res BW 100kHz Sweep 5ms

Occupied Bandwidth	Occ BW % Pwr	99.00 %
812.3202 kHz	x dB	-20.00 dB
Transmit Freq Error	-4.129 kHz	
x dB Bandwidth	901.092 kHz	

Invalid separator

Trace/View

Trace 1 2 3

Clear Write

Max Hold

Min Hold

View

Blank

More 1 of 2

5. EUT TEST PHOTO

Radiated Measurement Photos

