



2360

Radio Test Report
Cambridge Communication Systems Ltd
MetNet 60G
G60UM010000

47 CFR Part 15.255 Effective Date 1st October 2019
DXX: Part 15 Low Power Communication Device Transmitter
Test Date: 29th April 2021 to 5th May 2021
Report Number: 05-11962-1-21 Issue 02
Supersedes Report Number: 05-11962-1-21 Issue 01

R.N. Electronics Ltd.

Arnolds Court
Arnolds Farm Lane
Mountnessing
Essex
CM13 1UT
U.K.

www.RNelectronics.com

Telephone: +44 (0) 1277 352219
Email: sales@RNelectronics.com

This report is not to be reproduced by any means except in full and in any case not without the written approval of R.N. Electronics Ltd.



Arnolds Court, Arnolds Farm Lane, Mountnessing, Brentwood Essex, CM13 1UT

Certificate of Test 11962-1

The equipment noted below has been partially tested by R.N. Electronics Limited and, where appropriate, conforms to the relevant subpart of 47 CFR Part 15C. This is a certificate of test only and should not be confused with an equipment authorisation. Other standards may also apply.

Equipment:	MetNet 60G
Model Number:	G60UM010000
Unique Serial Number:	ASY038902000000868
Applicant:	Cambridge Communication Systems Ltd Victory House Chivers Way Histon Cambridge CB24 9ZR
Proposed FCC ID	2ACV4-M60G-xxx
Full measurement results are detailed in Report Number:	05-11962-1-21 Issue 02
Test Standards:	47 CFR Part 15.255 Effective Date 1st October 2019 DXX: Part 15 Low Power Communication Device Transmitter

NOTE:

The above list is incomplete as only partial tests conducted at request of the manufacturer. Certain tests were not performed based upon manufacturer's declarations. Certain other requirements are subject to manufacturer declaration only and have not been tested/verified. For details refer to section 3 of this report.

DEVIATIONS:

The following tests have had deviations applied: Radiated emissions above 1 GHz. The following tests have not been performed at the request of Cambridge Communication Systems Ltd: - AC power line conducted emissions, Peak Conducted Power, Frequency stability, 6 dB Occupied bandwidth, Peak & Average EIRP

This certificate relates only to the unit tested as identified by a unique serial number and in the condition at the time it was tested. It does not relate to any other similar equipment and performance of the product before or after the test cannot be guaranteed. Whilst every effort is made to assure quality of testing, type tests are not exhaustive and although no non-conformances may be found, this doesn't exclude the possibility of unit not meeting the intentions of the standard or the requirements of the Federal Regulations, particularly under different conditions to those during testing. Any compliance statements are made reliant on (a) the application of the product and use of the assigned band being acceptable to the FCC and (b) the modes of operation as instructed to us by the Customer based on their specific knowledge of the application and functionality of the EUT. Statements of compliance, where measurements were made, do not include the measurement uncertainty. The measurement uncertainty, where stated, is the expanded uncertainty based on a standard uncertainty multiplied by a coverage factor of k=2, providing a level of confidence of approximately 95%.

Date Of Test: 29th April 2021 to 5th May 2021

Test Engineer:

Approved By:
Technical Manager

Customer
Representative:



2360

0 Revision History

Issue Number	Revision History	Page Reference(s)
01	First Issue	-
02	Model number/HVIN reference table updated and models tested statement revised. Antenna Gain updated to 22dBi. Revised EIRP beam overlap text and included additional diagram demonstrating where beam overlap could occur between radios. Expanded notes explanation under summary table regarding partial testing. Expanded deviation explanation regarding partial testing. Expanded notes explanation regarding partial testing. Expanded procedure with reason for not testing above 26.5GHz and referenced report with results in.	5 7 9, 10 12 13 14, 21 18

1 Contents

0	Revision History	3
1	Contents	4
2	Equipment under test (EUT)	5
2.1	Equipment specification	5
2.2	Configurations for testing	7
2.3	Functional description	8
2.4	Modes of operation.....	8
2.5	Emissions configuration	9
3	Summary of test results	12
4	Specifications	13
4.1	Relevant standards	13
4.2	Deviations	13
5	Tests, methods and results	14
5.1	AC power line conducted emissions	14
5.2	Radiated emissions 9 - 150 kHz.....	14
5.3	Radiated emissions 150 kHz - 30 MHz	15
5.4	Radiated emissions 30 MHz -1 GHz	16
5.5	Radiated emissions above 1 GHz.....	18
5.6	Frequency stability	21
5.7	Peak & Average EIRP	21
5.8	Peak Conducted Power.....	21
5.9	6 dB Occupied bandwidth	21
6	Plots/Graphical results	22
6.1	Radiated emissions 150 kHz - 30 MHz	22
6.2	Radiated emissions 30 MHz -1 GHz	23
6.3	Radiated emissions above 1 GHz.....	25
7	Explanatory Notes.....	35
7.1	Explanation of Table of Signals Measured.....	35
7.2	Explanation of limit line calculations for radiated measurements	35
8	Photographs.....	37
8.1	EUT Front View	37
8.2	EUT Reverse Angle.....	37
8.3	EUT Left side View.....	38
8.4	EUT Right side View	38
8.5	EUT Antenna Port	39
8.6	EUT Display & Controls.....	39
8.7	EUT Internal photos	40
8.8	EUT ID Label.....	43
8.9	Radiated emissions 150 kHz - 30 MHz	43
8.10	Radiated emissions 30 MHz -1 GHz	44
8.11	Radiated emissions above 1 GHz.....	45
8.12	Radiated emission diagrams.....	48
8.13	AC powerline conducted emission diagram	49
9	Test equipment calibration list	50
10	Auxiliary and peripheral equipment.....	51
10.1	Customer supplied equipment.....	51
10.2	RN Electronics supplied equipment	51
11	Condition of the equipment tested	52
11.1	Modifications before test	52
11.2	Modifications during test.....	52
12	Description of test sites.....	53
13	Abbreviations and units.....	54

2 Equipment under test (EUT)

2.1 Equipment specification

Applicant	Cambridge Communication Systems Ltd Victory House Chivers Way Histon Cambridge CB24 9ZR	
Manufacturer of EUT	Cambridge Communication Systems Ltd (CCS)	
Full Name of EUT	MetNet 60G	
Model Number of EUT	G60UM010000	
Serial Number of EUT	ASY038902.000000868	
Date Received	23rd April 2021	
Date of Test:	29th April 2021 to 5th May 2021	
Purpose of Test	To demonstrate design compliance to the relevant rules of Chapter 47 of the Code of Federal Regulations.	
Date Report Issued	12th July 2021	
Main Function	60GHz mmWave Fixed Wireless Access backhaul.	
Information Specification	Height	270 mm
	Width	140 mm
	Depth	105 mm
	Weight	4 kg
	Voltage	100-240 V AC
	Current	1.2 A
EUT Supplied PSU	Manufacturer	TT Electronics
	Model number	STD-48025
	Serial number	-
	Input voltage	100-240V
	Input current	1.6 A
	Output	1 x 48 V DC @ 2.5 A

The CCS 60GHz Metnet Mesh V2 Node has several variants dependent upon the options fitted; options are power supply type, fibre optic expansion ports and colour. All variants have the same digital board, modem, gps, radios and metalwork.

A power supply must be fitted, the options are:-

AC Mains

48V DC/PoE combined relay switched

48V DC only, No PoE input

PoE only, No 48V DC input

All variants have the same metalwork and construction, the only exception being the top cover which has two extra access holes in the top cover when a fibre board is fitted.

A node can come in different colours, this is purely a cosmetic change, and currently a node is only available in black or grey.

The following Models/HVIN's are available for this EUT:

G60UM00 AC mains PSU without fibre

G60UM04 AC mains PSU with fibre

G60UM01 48V DC/PoE PSU, No Fibre

G60UM02 48V DC PSU, No Fibre

File Name: Cambridge Communication Systems Ltd.11962-1 Issue 02

QMF21J - Issue 05 - RNE Issue 03; 47 CFR Part 15C 2019

G60UM03 PoE PSU, No Fibre
G60UM05 48V DC/PoE PSU, Fibre
G60UM06 48V DC PSU, Fibre
G60UM07 PoE PSU, Fibre

HVIN/Model cross reference to Product code and variants:

HVIN	Description	Colour	Power	Fibre	Product Code
G60UM00	Metnet 60G Mesh v2	Black	AC	N/A	G60UM000000
G60UM01	Metnet 60G Mesh v2	Black	48vdc or PoE	N/A	G60UM010000
G60UM02	Metnet 60G Mesh v2	Black	48vdc only	N/A	G60UM020000
G60UM03	Metnet 60G Mesh v2	Black	PoE only	N/A	G60UM030000
G60UM04	Metnet 60G Mesh v2	Black	AC	1G/10G	G60UM040000
G60UM05	Metnet 60G Mesh v2	Black	48vdc or PoE	1G/10G	G60UM050000
G60UM06	Metnet 60G Mesh v2	Black	48vdc only	1G/10G	G60UM060000
G60UM07	Metnet 60G Mesh v2	Black	PoE only	1G/10G	G60UM070000
G60UM00	Metnet 60G Mesh v2	Grey	AC	N/A	G60UM000088
G60UM01	Metnet 60G Mesh v2	Grey	48vdc or PoE	N/A	G60UM010088
G60UM02	Metnet 60G Mesh v2	Grey	48vdc only	N/A	G60UM020088
G60UM03	Metnet 60G Mesh v2	Grey	PoE only	N/A	G60UM030088
G60UM04	Metnet 60G Mesh v2	Grey	AC	1G/10G	G60UM040088
G60UM05	Metnet 60G Mesh v2	Grey	48vdc or PoE	1G/10G	G60UM050088
G60UM06	Metnet 60G Mesh v2	Grey	48vdc only	1G/10G	G60UM060088
G60UM07	Metnet 60G Mesh v2	Grey	PoE only	1G/10G	G60UM070088

Models listed in Green in the table above are covered by this test report. Namely G60UM01, G60UM02, and G60UM03. G60UM01 was considered worst case for tests as it included both 48 V dc and PoE methods of powering the unit.

Some tests have not been applied or only partial test ranges have been applied within this report, this is due to the following rationale:

All models contain identical radio configurations, have the same digital board, same modem, same gps, and utilise the same metalwork, only the method of powering changes, these 3 models/HVIN's do not contain a fibre port board.

For this reason, only radiated emissions were performed up to 26.5GHz to encompass any differences in emissions between power supply methods. AC emissions testing was not performed as worst case loading is with the addition of the fibre board and as such is covered in RN report 05-11691-1-21.

2.2 Configurations for testing

General Parameters	
EUT Normal use position	Vertically mounted
Choice of model(s) for type tests	Production samples
Antenna details	Integral. Phase array beamforming. 22 dBi gain.
Antenna port	None
Baseband Data port (yes/no)?	No
Highest Signal generated in EUT	69.12 GHz
Lowest Signal generated in EUT	25 MHz
Hardware Version	V1.0
Software Version	radio-integration-unreleased-154
Firmware Version	-
Type of Equipment	60 GHz radio
Technology Type	IEEE 802.11 ad
Geo-location (yes/no)	Yes
TX Parameters	
Alignment range – transmitter	57-71 GHz
EUT Declared Modulation Parameters	DSSS, BPSK, QPSK, 16QAM
EUT Declared Power level	+40 dBm EIRP
EUT Declared Signal Bandwidths	2.16 GHz
EUT Declared Channel Spacing's	2.16 Ghz
EUT Declared Duty Cycle	Not declared
Unmodulated carrier available?	Yes
Declared frequency stability	Not declared
RX Parameters	
Alignment range – receiver	57-71 GHz
EUT Declared RX Signal Bandwidth	2.16 GHz
Receiver Signal Level (RSL)	Not declared
Method of Monitoring Receiver BER	1 % PER
FCC Parameters	
FCC Transmitter Class	DXX Part 15 Low Power Communication Device Transmitter

2.3 Functional description

The product is a 60GHz 802.11 ad transceiver node capable of sustaining simultaneous links with multiple CPE providing and to provide wireless backhaul for access equipment such as cellular base stations.

- Topologies
 - MultiPoint-to-MultiPoint (MPtMP) mesh
 - Point-to-MultiPoint (PtMP)
 - Point-to-Point (PtP)

The product is designed to be mounted on street furniture such as a pole, lamppost or residential or commercial property.

2.4 Modes of operation

TX1	Transmitting 58.32 GHz 40 dBm mcs0	No
TX2	Transmitting 58.32 GHz 40 dBm mcs1	No
TX3	Transmitting 58.32 GHz 40 dBm mcs2	No
TX4	Transmitting 58.32 GHz 40 dBm mcs3	No
TX5	Transmitting 58.32 GHz 40 dBm mcs4	No
TX6	Transmitting 58.32 GHz 40 dBm mcs5	Yes
TX7	Transmitting 58.32 GHz 40 dBm mcs6	No
TX8	Transmitting 58.32 GHz 40 dBm mcs7	No
TX9	Transmitting 58.32 GHz 40 dBm mcs8	No
TX10	Transmitting 58.32 GHz 40 dBm mcs9	No
TX11	Transmitting 58.32 GHz 40 dBm mcs10	No
TX12	Transmitting 58.32 GHz 40 dBm mcs11	No
TX13	Transmitting 58.32 GHz 40 dBm mcs12	No
TX14	Transmitting 62.64 GHz 40 dBm mcs0	No
TX15	Transmitting 62.64 GHz 40 dBm mcs1	No
TX16	Transmitting 62.64 GHz 40 dBm mcs2	No
TX17	Transmitting 62.64 GHz 40 dBm mcs3	No
TX18	Transmitting 62.64 GHz 40 dBm mcs4	No
TX19	Transmitting 62.64 GHz 40 dBm mcs5	Yes
TX20	Transmitting 62.64 GHz 40 dBm mcs6	No
TX21	Transmitting 62.64 GHz 40 dBm mcs7	No
TX22	Transmitting 62.64 GHz 40 dBm mcs8	No
TX23	Transmitting 62.64 GHz 40 dBm mcs9	No
TX24	Transmitting 62.64 GHz 40 dBm mcs10	No
TX25	Transmitting 62.64 GHz 40 dBm mcs11	No
TX26	Transmitting 62.64 GHz 40 dBm mcs12	No
TX27	Transmitting 69.12 GHz 40 dBm mcs0	No
TX28	Transmitting 69.12 GHz 40 dBm mcs1	No
TX29	Transmitting 69.12 GHz 40 dBm mcs2	No
TX30	Transmitting 69.12 GHz 40 dBm mcs3	No
TX31	Transmitting 69.12 GHz 40 dBm mcs4	No
TX32	Transmitting 69.12 GHz 40 dBm mcs5	Yes
TX33	Transmitting 69.12 GHz 40 dBm mcs6	No
TX34	Transmitting 69.12 GHz 40 dBm mcs7	No
TX35	Transmitting 69.12 GHz 40 dBm mcs8	No
TX36	Transmitting 69.12 GHz 40 dBm mcs9	No
TX37	Transmitting 69.12 GHz 40 dBm mcs10	No
TX38	Transmitting 69.12 GHz 40 dBm mcs11	No
TX39	Transmitting 69.12 GHz 40 dBm mcs12	No
TX40	Transmitting CW 58.32 GHz 99.687 MHz tone	No
TX41	Transmitting CW 62.64 GHz 99.687 MHz tone	No

2.5 Emissions configuration

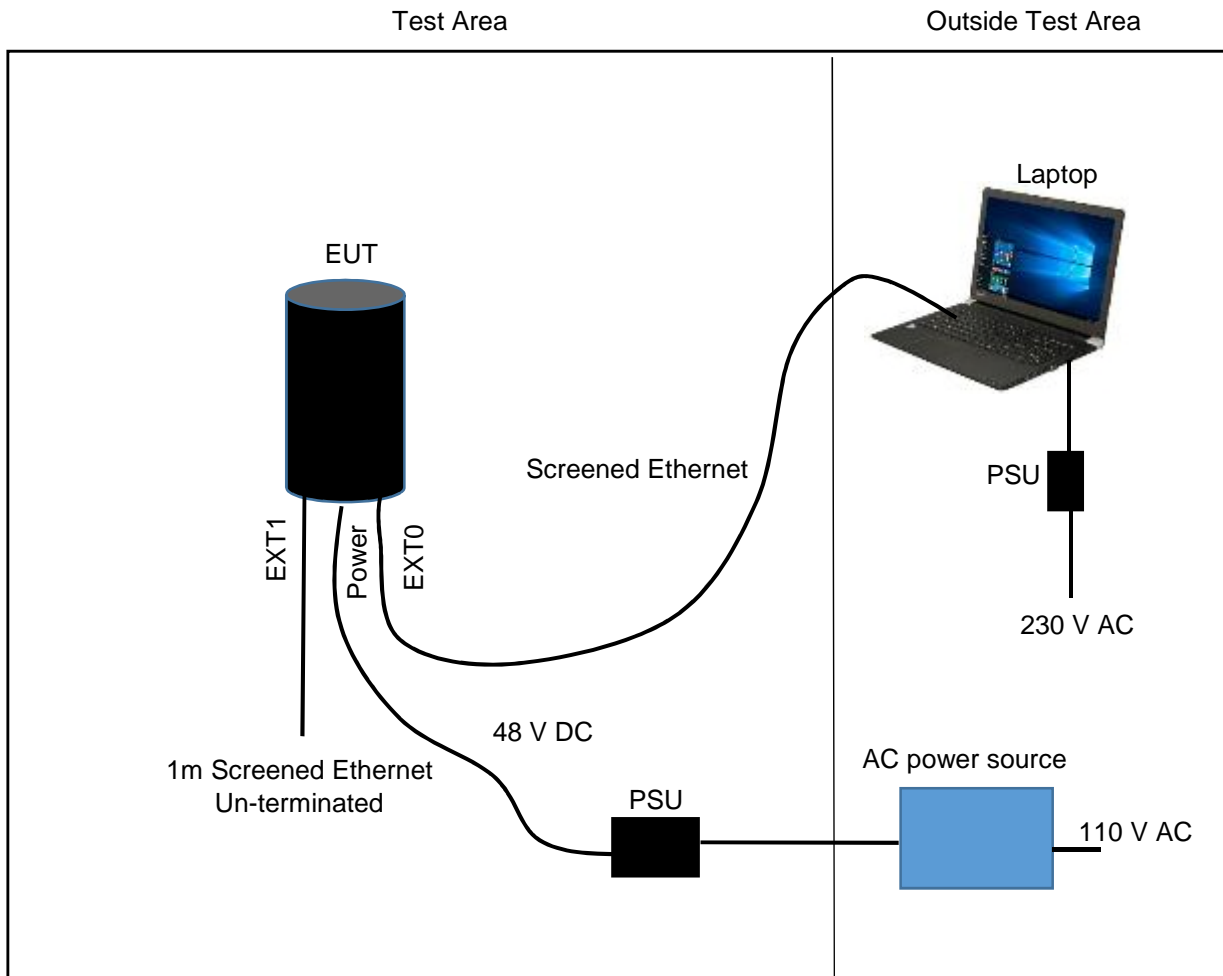

The unit was powered from 48 V DC via a power adaptor from 110 V AC mains. The unit was configured with engineering menus via a terminal program to allow permanent transmit modes of the device on the each of 4 radios, and on the channels and modulation schemes as stated within section 2.4 of this report. The applicant declares that each radio operates on a different channel and that they can transmit at the same time. In addition, each radio allows circular beam steering as defined in ANSI C63.10 section 13. The beam value is settable between 0 and 64, with 0 being omnidirectional and 1 to 63 being a sector angle. The applicant declares that it is possible for beam overlap from adjacent radios (but each radio is on a different channel). RN Electronics performed initial investigations in 0.5° steps on each of the radios through a 360° EUT rotation for all beam settings. The -3 dB beamwidth was found to be approximately $\pm 4^\circ$ and is steerable over roughly 95° thereby providing near 360° coverage with all four radios. It was found that individual antenna beamwidth increased slightly on antenna beams at each end of the antenna arrays, but EIRP from those same beam settings at the outer arrays was reduced. From this information it was possible to determine the effect of having adjacent radios with beam overlap and where maximum EIRP would occur. Highest EIRP was still measured when there was no beam overlap.

Additional information provided by CCS Ltd confirmed where beam overlap could occur between specific radios:

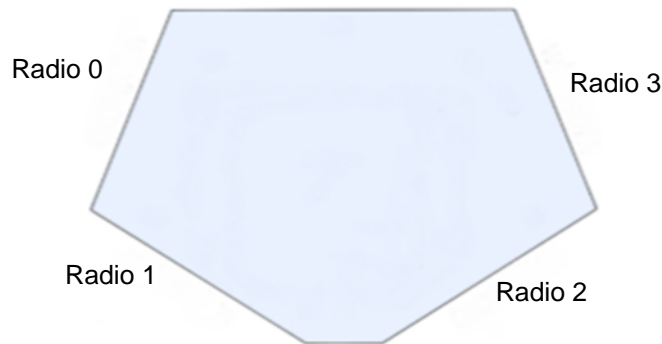
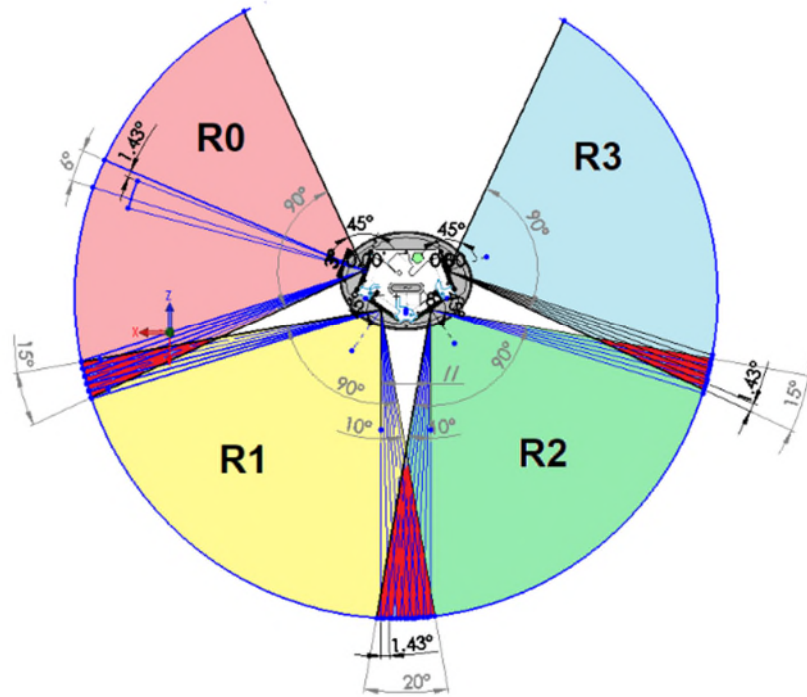

View from above showing arrangement of radios

- Channel 1 = 58.32 GHz, power level +40 dBm (all modulation schemes)
- Channel 2 = 60.48 GHz, power level +40 dBm (all modulation schemes)
- Channel 3 = 62.64 GHz, power level +40 dBm (all modulation schemes)
- Channel 4 = 64.8 GHz, power level +40 dBm (all modulation schemes)
- Channel 5 = 66.96 GHz, power level +40 dBm (all modulation schemes)
- Channel 6 = 69.12 GHz, power level +40 dBm (all modulation schemes)

Modulation schemes available were DBPSK (MCS0), BPSK (MCS1 to MCS5), QPSK (MCS6 to MCS9) and 16QAM (MCS10 to MCS12).

Measured duty cycles for the schemes were as follows (MCS0 declared as not in use by applicant): -

- MCS1 99.8 %
- MCS2 99.5 %
- MCS3 99.4 %
- MCS4 99.3 %
- MCS5 99.2 %
- MCS6 99 %

MCS7 98.8 %
MCS8 98.6 %
MCS9 98.5 %
MCS10 98.1 %
MCS11 97.7 %
MCS12 97.3 %

2.5.1 Signal leads

Port Name	Cable Type	Connected
Power (AC)	Exterior grade cable. Commercial connector	Yes
EXT0	CAT5e screened. RJ45 connector	Yes
EXT1	CAT5e screened. RJ45 connector	Yes

3 Summary of test results

The MetNet 60G, G60UM010000 was tested for compliance to the following standard(s):

47 CFR Part 15.255 Effective Date 1st October 2019
DXX: Part 15 Low Power Communication Device Transmitter

Any compliance statements are made reliant on (a) the application of the product and use of the assigned band being acceptable to the FCC and (b) the modes of operation as instructed to us by the Customer based on their specific knowledge of the application and functionality of the EUT. Whilst every effort is made to assure quality of testing, type tests are not exhaustive and although no non-conformances may be found, this doesn't exclude the possibility of equipment not meeting the intentions of the standard or the essential requirements of the directive, particularly under different conditions to those during testing. Statements of compliance, where measurements were made, do not include the measurement uncertainty. The measurement uncertainty, where stated, is the expanded uncertainty based on a standard uncertainty multiplied by a coverage factor of k=2, providing a level of confidence of approximately 95%.

Title	References	Results
Transmitter Tests		
1. AC power line conducted emissions	47 CFR Part 15C Part 15.207	NOT TESTED ¹
2. Radiated emissions 9 - 150 kHz	47 CFR Part 15C Part 15.209	NOT APPLICABLE ²
3. Radiated emissions 150 kHz - 30 MHz	47 CFR Part 15C Part 15.209	PASSED
4. Radiated emissions 30 MHz -1 GHz	47 CFR Part 15C Part 15.255(d)(2)	PASSED
5. Radiated emissions above 1 GHz	47 CFR Part 15C Part 15.255(d)(2)/(3)/(4)	PASSED ³
6. Frequency stability	47 CFR Part 15C Part 15.255(f)	NOT TESTED ⁴
7. Peak & Average EIRP	47 CFR Part 15C Part 15.255(c)(1)(i)/(ii)	NOT TESTED ⁴
8. Peak Conducted Power	47 CFR Part 15C Part 15.255(c)(3)/(4)	NOT TESTED ⁴
9. 6dB Occupied bandwidth	47 CFR Part 15C Part 15.255(e)(1)	NOT TESTED ⁴

¹ Not tested at the request of applicant. AC emissions testing was not performed as worst case loading is with the addition of the fibre board and as such is covered in RN report 05-11691-1-21.

² Spectrum below 30MHz started at a frequency of 150 kHz up to a frequency of 30MHz based on the lowest signal generated/used within the equipment of 25 MHz as declared by the applicant.

³ Spectrum investigated up to 26.5 GHz at the request of the applicant, for results above 26.5GHz please refer to RN report 05-11387-1-21 as Radio configuration is identical between EUT models/HVIN's.

⁴ Radio configuration is identical between EUT models/HVIN's, please refer to RN report 05-11387-1-21 for results of these tests.

4 Specifications

The tests were performed and operated in accordance with R.N. Electronics Ltd procedures and the relevant standards listed below.

4.1 Relevant standards

Ref.	Standard Number	Version	Description
4.1.1	47 CFR Part 15C	2019	Federal Communications Commission PART 15 – RADIO FREQUENCY DEVICES
4.1.2	ANSI C63.10	2013	American National Standard of Procedures for Compliance Testing of Unlicensed Wireless Devices
4.1.3	ANSI C63.4	2014	American National Standard for Methods of Measurement of Radio-Noise Emissions from Low-Voltage Electrical and Electronic Equipment in the Range of 9 kHz to 40 GHz
4.1.4	KDB 842590 D01 v01	2019	Federal Communications Commission Office of Engineering and Technology Laboratory Division; Basic certification requirements and measurement procedures for Upper Microwave Flexible Use Service (UMFUS) devices

4.2 Deviations

Deviations have been applied on the following: Radiated emissions above 1 GHz : Frequency of investigation limited to 26.5 GHz at the request of the applicant, for results above 26.5GHz please refer to RN report 05-11387-1-21 as Radio configuration is identical between EUT models/HVIN's.

The following tests have not been performed at the request of Cambridge Communication Systems Ltd:- AC power line conducted emissions, AC emissions testing was not performed as worst case loading is with the addition of the fibre board and as such is covered in RN report 05-11691-1-21.

Peak Conducted Power, Frequency stability, 6 dB Occupied bandwidth, Peak & Average EIRP, These tests were not performed as Radio configuration is identical between EUT models/HVIN's, please refer to RN report 05-11387-1-21 for results of these tests.

5 Tests, methods and results

5.1 AC power line conducted emissions

NOT TESTED: Not tested at request of applicant, AC emissions testing was not performed as worst case loading is with the addition of the fibre board and as such is covered in RN report 05-11691-1-21.

5.2 Radiated emissions 9 - 150 kHz

NOT APPLICABLE: Spectrum below 30MHz started at a frequency of 150 kHz based on the lowest declared signal generated within the equipment of 25 MHz.

5.3 Radiated emissions 150 kHz - 30 MHz

5.3.1 Test methods

Test Requirements: 47 CFR Part 15C Part 15.255(d)(2) [Reference 4.1.1 of this report]
 Test Method: ANSI C63.10 Clause 6.3 & 6.4 [Reference 4.1.2 of this report]
 Limits: 47 CFR Part 15C Part 15.209/15.255(d)(2) [Reference 4.1.1 of this report]

5.3.2 Configuration of EUT

The EUT was placed on a 0.8 metres high turntable. The front edge of the EUT was initially positioned facing the antenna. The EUT was measured at a distance of 3 metres. The EUT was examined in its normal use position. During the initial scan worst case was seen when powered from 48 V DC rather than PoE. Radiated Emissions testing was performed with the EUT powered from 48 V DC. During the initial scan no discernible difference in emissions could be observed when operating on different channels or modulation schemes. The EUT was operated with all four radios in TX19 mode.

5.3.3 Test procedure

Tests were made in accordance with FCC Part 15 using the measuring equipment noted below.

Measurements were made in a semi-anechoic chamber (pre-scan) with any final measurements required performed on an OATS without a ground plane. The antenna was placed 1m above the ground. The equipment was rotated 360 degrees to record the worst case emissions.

At least 6 signals within 20dB and all signals within 10dB of the limit were investigated.

Tests were performed using Test Site M.

5.3.4 Test equipment

TMS81, ZSW1, E624, E411

See Section 9 for more details

5.3.5 Test results

Temperature of test environment 18°C
 Humidity of test environment 36%
 Pressure of test environment 102kPa

Band	57-71 GHz
Power Level	40 dBm (EIRP)
Channel Spacing	2.16 GHz
Mod Scheme	mcs5
Single channel	62.64 GHz

Plot refs
11962-1 Rad 1 150k-30MHz Para
11962-1 Rad 1 150k-30MHz Perp

Peak detector "Max held" Analyser plots against the Quasi-Peak / Average limit line(s) can be found in Section 6 of this report.

LIMITS:

15.209 limits are applicable in the restricted bands of 15.205 with the relevant detector. The general limits of 15.209 are as drawn on the respective plots.

These results show that the EUT has PASSED this test.

The uncertainty gives a 95% confidence interval in the measurement. Expanded uncertainty (K=2) is as follows:

9kHz - 30MHz ±3.9dB.

5.4 Radiated emissions 30 MHz - 1 GHz

5.4.1 Test methods

Test Requirements:	47 CFR Part 15C Part 15.255(d)(2) [Reference 4.1.1 of this report]
Test Method:	ANSI C63.10 Clause 6.3 & 6.5 [Reference 4.1.2 of this report]
Limits:	47 CFR Part 15C Part 15.255(d)(2) [Reference 4.1.1 of this report]

5.4.2 Configuration of EUT

The EUT was placed on a 0.8 metres high turntable. The front edge of the EUT was initially positioned facing the antenna. The EUT was measured at a distance of 3 metres. The EUT was examined in its normal use position. During the initial scan worst case was seen when powered from 48 V DC rather than PoE. Radiated Emissions testing was performed with the EUT powered from 48 V DC. During the initial scan no discernible difference in emissions could be observed when operating on different channels or modulation schemes. The EUT was operated with all four radios in TX19 mode.

5.4.3 Test procedure

Tests were made in accordance with FCC Part 15 using the measuring equipment listed below. Measurements were made on a site listed with the FCC. The equipment was rotated 360 degrees and the antenna scanned 1 – 4 metres in both horizontal and vertical polarisations to record the worst case emissions.

At least 6 signals within 20dB and all signals within 10dB of the limit were investigated.

Tests were performed using Test Site M.

5.4.4 Test equipment

LPE364, E743, NSA-M, ZSW1, E624, E411

See Section 9 for more details

5.4.5 Test results

Temperature of test environment	18°C
Humidity of test environment	36%
Pressure of test environment	102kPa

Band	57-71 GHz
Power Level	40 dBm (EIRP)
Channel Spacing	2.16 GHz
Mod Scheme	mcs5
Mid channel	6.64 GHz

Plot refs	
11962-1 Rad 1 VHF Horiz	
11962-1 Rad 1 VHF Vert	
11962-1 Rad 1 UHF Horiz	
11962-1 Rad 1 UHF Vert	

Table of signals measured for Rad 1 Horizontal Sig List

Signal No.	Freq (MHz)	Peak Amp (dBuV/m)	QP Amp (dBuV/m)	QP -Lim (dB)
1	42.334	24.2	17.8	-22.2
2	46.650	23.9	18.3	-21.7
3	124.676	23.7	17.0	-26.5
4	246.868	26.3	20.6	-25.4
5	257.145	27.8	21.4	-24.6
6	627.884	35.7	29.4	-16.6
7	795.533	34.6	28.9	-17.1

Table of signals measured for Rad 1 Vertical Sig List

Signal No.	Freq (MHz)	Peak Amp (dBuV/m)	QP Amp (dBuV/m)	QP -Lim (dB)
1	42.683	26.9	21.6	-18.4
2	50.875	30.0	20.7	-19.3
3	57.590	25.6	20.3	-19.7
4	96.341	25.5	19.7	-23.8
5	100.804	25.9	20.4	-23.1
6	212.834	24.7	17.4	-26.1
7	247.953	27.5	21.2	-24.8
8	277.032	26.5	20.5	-25.5
9	305.070	26.9	21.2	-24.8
10	438.534	31.4	24.6	-21.4
11	476.713	32.6	25.6	-20.4
12	567.401	33.7	27.5	-18.5

Peak detector “Max held” Analyser plots against the Quasi-Peak / Average limit line(s) can be found in Section 6 of this report.

Whilst Low, Mid and High channels were tested, plots are for illustrative purposes only and only Mid channel plots are shown in this report.

LIMITS:

15.209 limits are applicable in the restricted bands of 15.205 with the relevant detector. The general limits of 15.209 are as drawn on the respective plots.

These results show that the EUT has PASSED this test.

The uncertainty gives a 95% confidence interval in the measurement. Expanded uncertainty (K=2) is as follows:

30MHz - 1000MHz ±6.1dB.

5.5 Radiated emissions above 1 GHz

5.5.1 Test methods

Test Requirements:	47 CFR Part 15C Part 15.255(d)(2)/(3)/(4) [Reference 4.1.1 of this report]
Test Method:	ANSI C63.10 Clause 6.3 & 6.6 & 9.8 [Reference 4.1.2 of this report]
Limits:	47 CFR Part 15C Part 15.255(d)(2)/(3)/(4) [Reference 4.1.1 of this report]

5.5.2 Configuration of EUT

The EUT was placed on a 1.5 metres high turntable. The front edge of the EUT was initially positioned facing the antenna. The EUT was measured at a distance listed in 5.5.3. The EUT was examined in its normal use position. During the initial scan worst case was seen when powered from 48 V DC rather than PoE. Radiated Emissions testing was performed with the EUT powered from 48 V DC. During the initial scan no modulation scheme was seen to be worst case so mcs5 was used. The EUT was operated with all four radios in TX6, TX19 and TX32 modes.

5.5.3 Test procedure

Tests were made in accordance with FCC Part 15 using the measuring equipment listed below. Measurements were made in a semi-anechoic chamber with appropriate absorbing material for use in this range. Horn antennas were used at heights where the whole of the EUT was contained within the main beam. The EUT was rotated through 360 degrees to record the worst case emissions. A measurement distance of 3m was used between the test range 1 - 6GHz, 1.2m was used in the test range 6 - 18GHz, 0.5m was used in the test range 18 – 26.5GHz. As Radio configuration is identical between EUT models/HVIN's, for results above 26.5GHz please refer to RN report 05-11387-1-21.

At least 6 signals within 20dB and all signals within 10dB of the limit were investigated.

Tests were performed using test Site M.

5.5.4 Test equipment

E136, E404, E411, E624, E743, LPE364, TMS78

See Section 9 for more details

5.5.5 Test results

Temperature of test environment	20°C
Humidity of test environment	50%
Pressure of test environment	102kPa

Setup Table

Band	57-71 GHz
Power Level	40 dBm (EIRP)
Channel Spacing	2.16 GHz
Mod Scheme	mcs5
Low channel	58.32 GHz

Spurious Frequency (MHz)	Measured Peak Level (dBµV/m)	Difference to Peak Limit (dB)	Measured Average Level (dBµV/m)	Difference to Average Limit (dB)	EUT Polarisation	Antenna Polarisation
2474.997	45.6	-28.4	42.6	-11.4	Upright	Vertical
2474.998	41.8	-32.2	36.7	-17.3	Upright	Horizontal
2499.997	44.9	-29.1	40	-14	Upright	Vertical
2499.998	46.5	-27.5	42.6	-11.4	Upright	Horizontal
4999.994	47.4	-26.6	42.7	-11.3	Upright	Vertical
4999.995	47.2	-26.8	41.7	-12.3	Upright	Horizontal

Setup Table

Band	57-71 GHz
Power Level	40 dBm (EIRP)
Channel Spacing	2.16 GHz
Mod Scheme	mcs5
Mid channel	62.64 GHz

Spurious Frequency (MHz)	Measured Peak Level (dBµV/m)	Difference to Peak Limit (dB)	Measured Average Level (dBµV/m)	Difference to Average Limit (dB)	EUT Polarisation	Antenna Polarisation
2474.997	45.6	-28.4	42.6	-11.4	Upright	Vertical
2474.998	41.8	-32.2	36.7	-17.3	Upright	Horizontal
2499.997	44.9	-29.1	40	-14	Upright	Vertical
2499.998	46.5	-27.5	42.6	-11.4	Upright	Horizontal
4999.994	47.4	-26.6	42.7	-11.3	Upright	Vertical
4999.995	47.2	-26.8	41.7	-12.3	Upright	Horizontal

Plots

11962-1 Rad 1 1-2GHz Horiz
11962-1 Rad 1 1-2GHz Vert
11962-1 Rad 1 2-5GHz Horiz
11962-1 Rad 1 2-5GHz Vert
11962-1 Rad 1 5-6GHz Horiz
11962-1 Rad 1 5-6GHz Vert
11962-1 Rad 1 6upto10GHz Horiz
11962-1 Rad 1 6upto10GHz Vert
11962-1 Rad 1 10upto12_5GHz Horiz
11962-1 Rad 1 10upto12_5GHz Vert
11962-1 12.5-15 Horiz
11962-1 12.5-15 Vert
11962-1 15-18 Horiz
11962-1 15-18 Vert
11962-1 Horiz 18-21GHz
11962-1 Vert 18-21GHz
11962-1 Horiz 21-23GHz
11962-1 Vert 21-23GHz
11962-1 Horiz 23-26.5GHz
11962-1 Vert 23-26.5GHz

Setup Table

Band	57-71 GHz
Power Level	40 dBm (EIRP)
Channel Spacing	2.16 GHz
Mod Scheme	mcs5
High channel	69.12 GHz

Spurious Frequency (MHz)	Measured Peak Level (dBµV/m)	Difference to Peak Limit (dB)	Measured Average Level (dBµV/m)	Difference to Average Limit (dB)	EUT Polarisation	Antenna Polarisation
2474.997	45.6	-28.4	42.6	-11.4	Upright	Vertical
2474.998	41.8	-32.2	36.7	-17.3	Upright	Horizontal
2499.997	44.9	-29.1	40	-14	Upright	Vertical
2499.998	46.5	-27.5	42.6	-11.4	Upright	Horizontal
4999.994	47.4	-26.6	42.7	-11.3	Upright	Vertical
4999.995	47.2	-26.8	41.7	-12.3	Upright	Horizontal

Peak detector "Max held" Analyser plots against the average limit line can be found in Section 6 of this report.

Note: Whilst Low, Mid and High channels were tested, plots are for illustrative purposes only and only Mid channel plots are shown in this report.

LIMITS:

15.209 limits are applicable in the restricted bands of 15.205 with the relevant detector.

The general limits of 15.209 are as drawn on the respective plots.

These results show that the EUT has PASSED this test.

The uncertainty gives a 95% confidence interval in the measurement. Expanded uncertainty (K=2) is as follows:
1 – 18 GHz ± 3.5 dB, 18 – 26.5 GHz ± 3.9 dB.

5.6 Frequency stability

NOT TESTED: Not tested at request of applicant as Radio configuration is identical between EUT models/HVIN's, please refer to RN report 05-11387-1-21 for results of these tests.

5.7 Peak & Average EIRP

NOT TESTED: Not tested at request of applicant as Radio configuration is identical between EUT models/HVIN's, please refer to RN report 05-11387-1-21 for results of these tests.

5.8 Peak Conducted Power

NOT TESTED: Not tested at request of applicant as Radio configuration is identical between EUT models/HVIN's, please refer to RN report 05-11387-1-21 for results of these tests.

5.9 6 dB Occupied bandwidth

NOT TESTED: Not tested at request of applicant as Radio configuration is identical between EUT models/HVIN's, please refer to RN report 05-11387-1-21 for results of these tests.

6 Plots/Graphical results

6.1 Radiated emissions 150 kHz - 30 MHz

RF Parameters: Band 57-71 GHz, Power 40 dBm (EIRP), Channel Spacing 2.16 GHz, Modulation mcs5, Channel 62.64 GHz

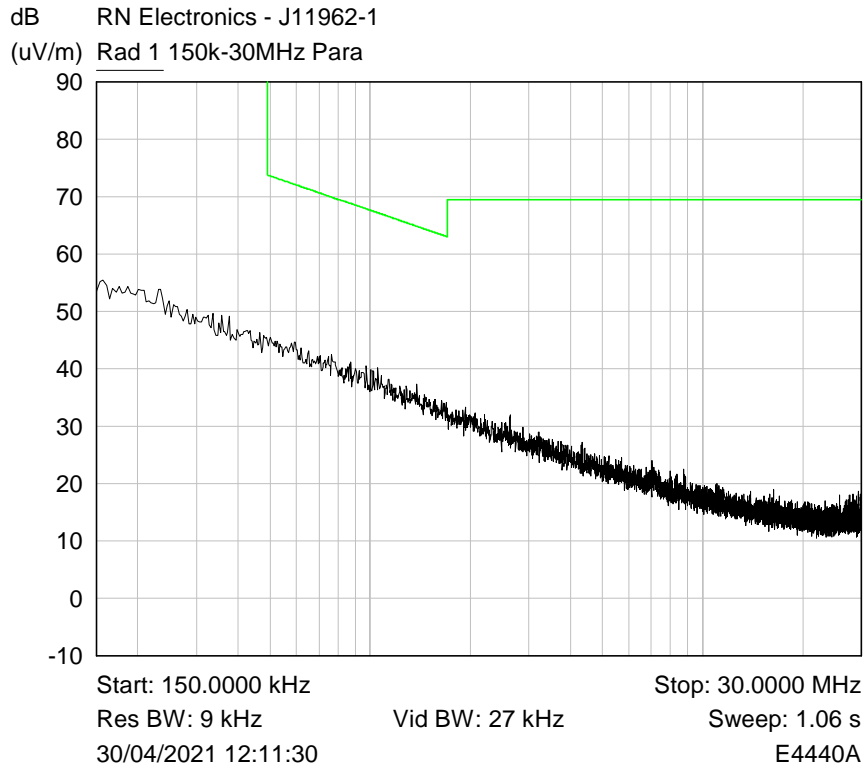

Plot of 150kHz-30MHz Parallel

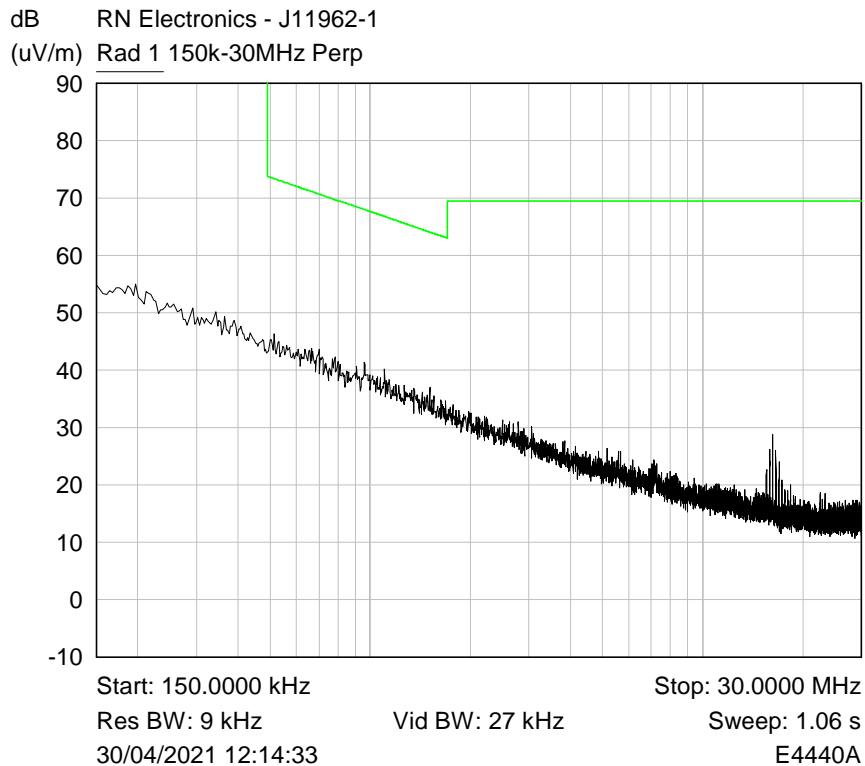

Plot of 150kHz-30MHz Perpendicular

6.2 Radiated emissions 30 MHz -1 GHz

RF Parameters: Band 57-71 GHz, Power 40 dBm (EIRP), Channel Spacing 2.16 GHz,
Modulation mcs5, Channel 58.32 GHz

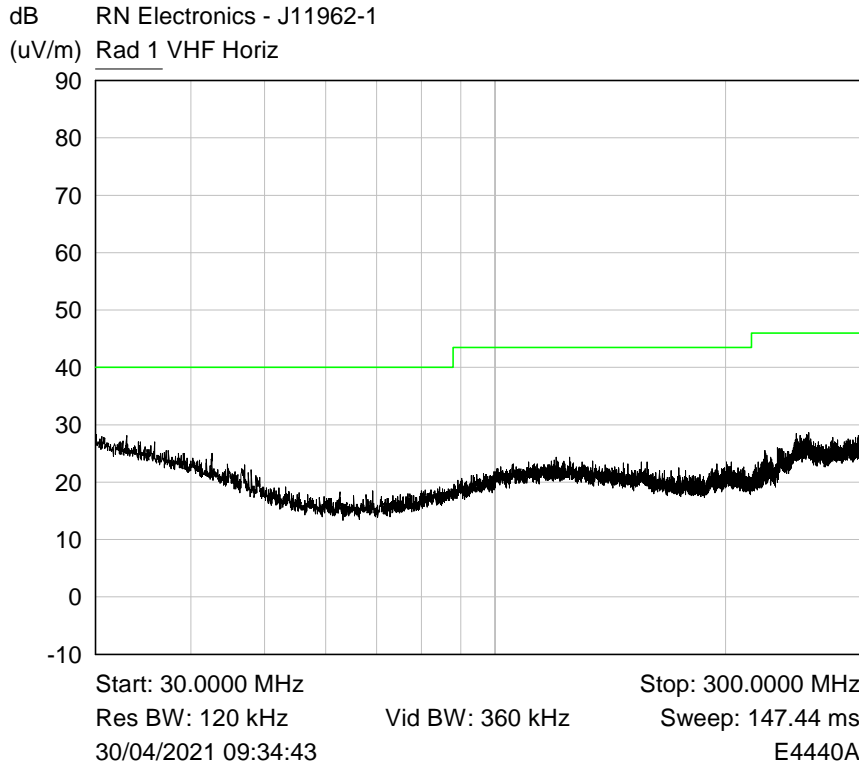

Plot of Peak emissions for VHF Horizontal against the QP limit line.

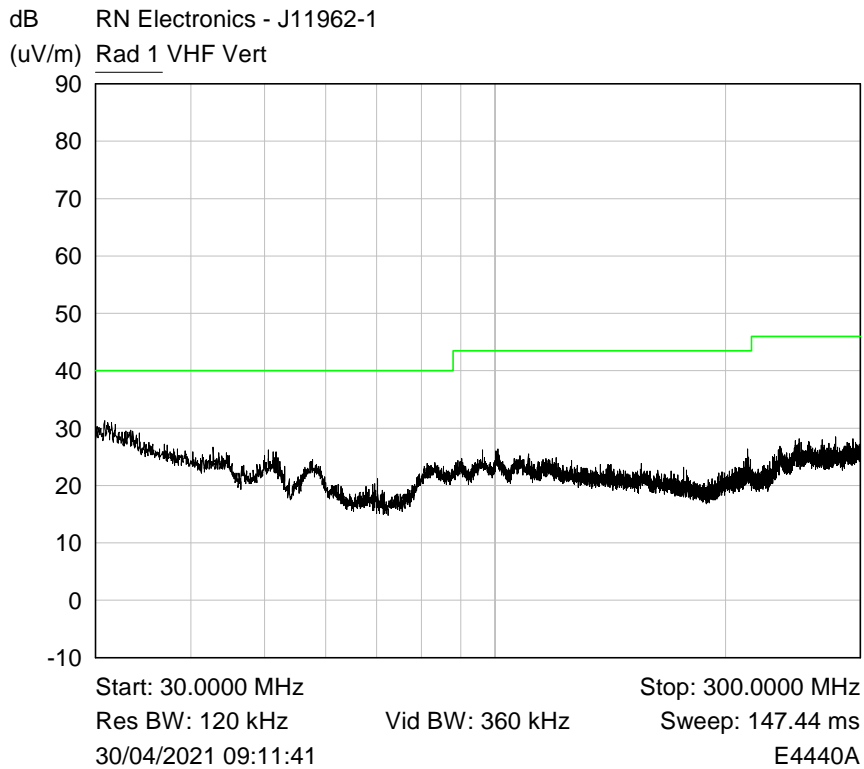

Plot of Peak emissions for VHF Vertical against the QP limit line.

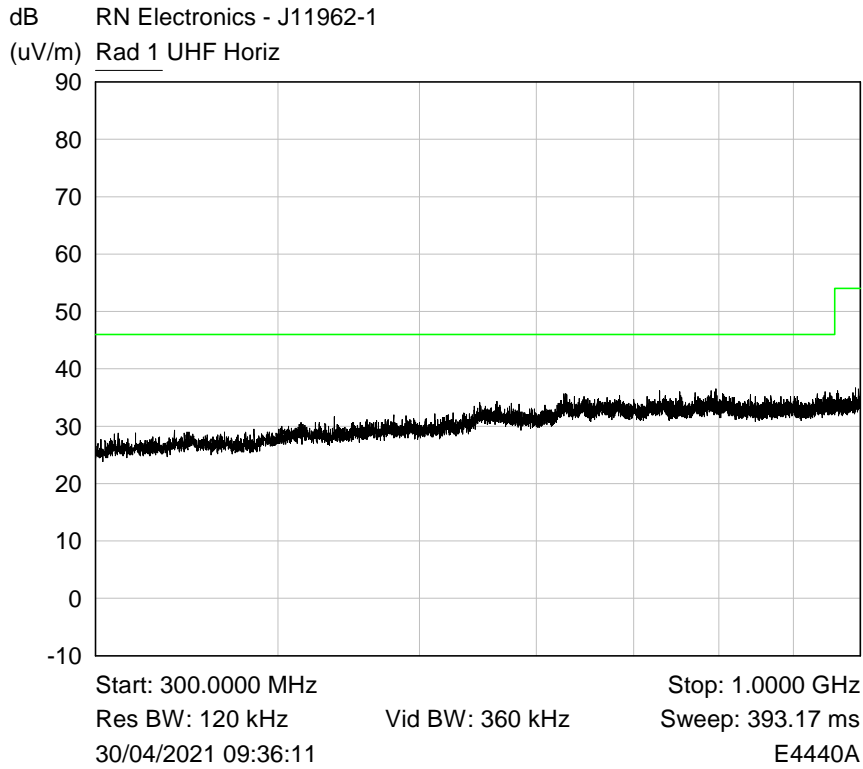

Plot of Peak emissions for UHF Horizontal against the QP limit line.

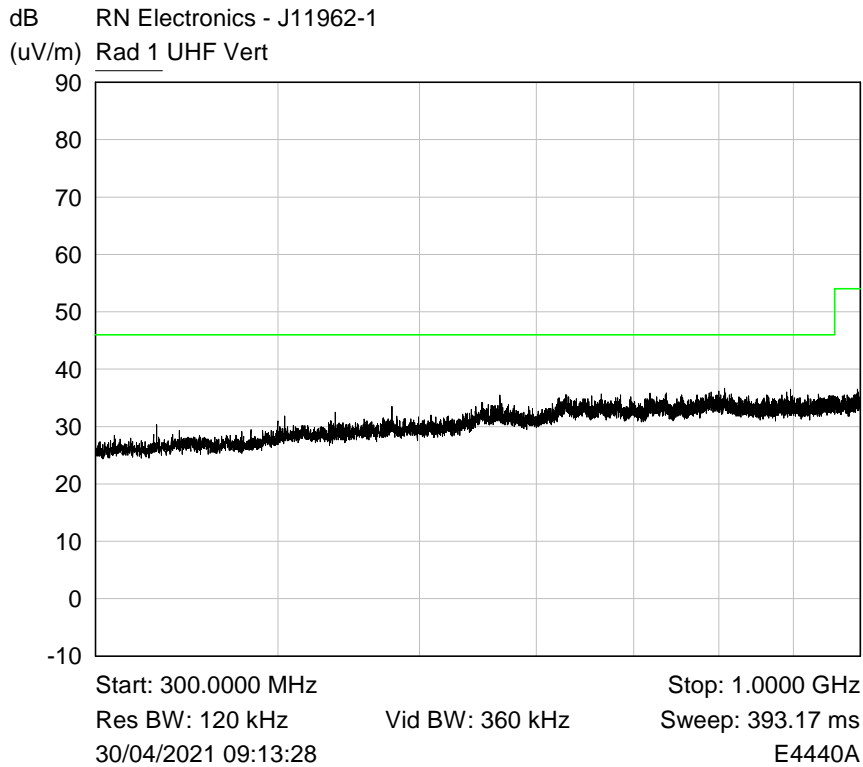

Plot of Peak emissions for UHF Vertical against the QP limit line.

6.3 Radiated emissions above 1 GHz

RF Parameters: Band 57-71 GHz, Power 40 dBm (EIRP), Channel Spacing 2.16 GHz,
Modulation mcs5, Channel 62.64 GHz

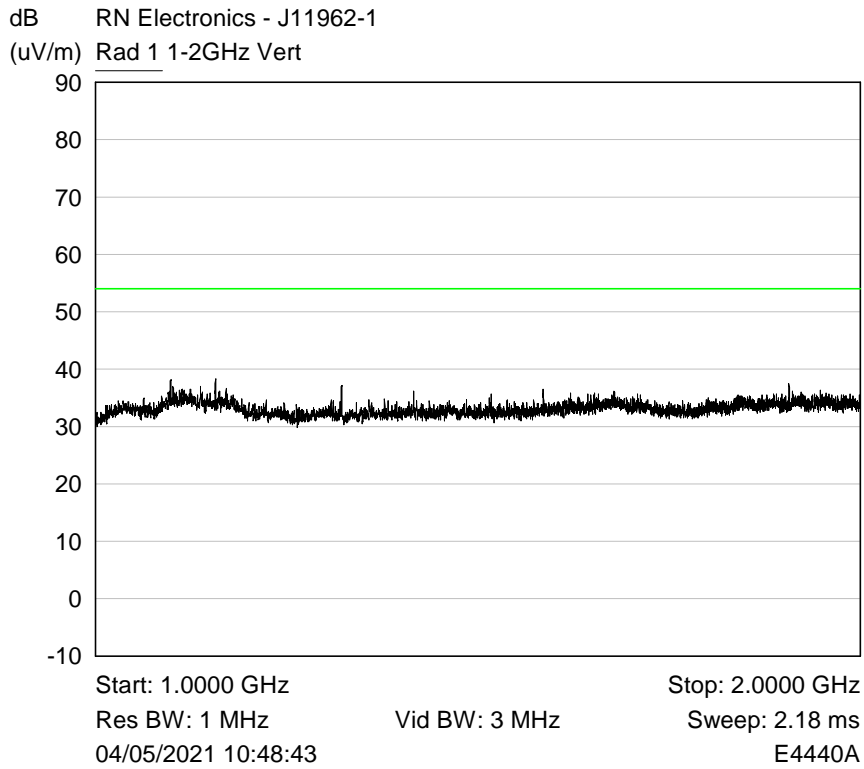
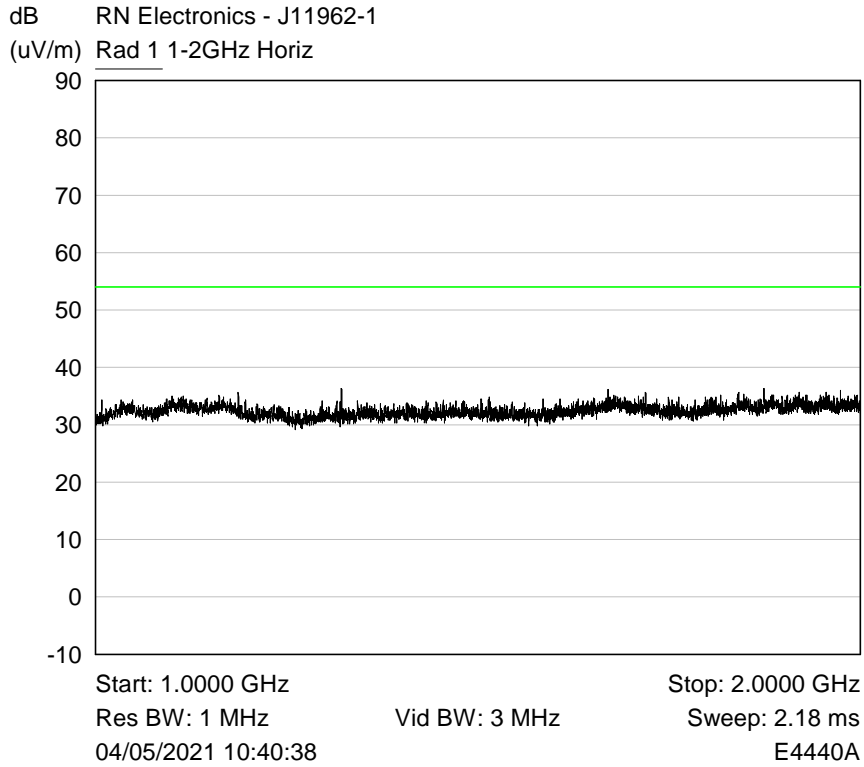

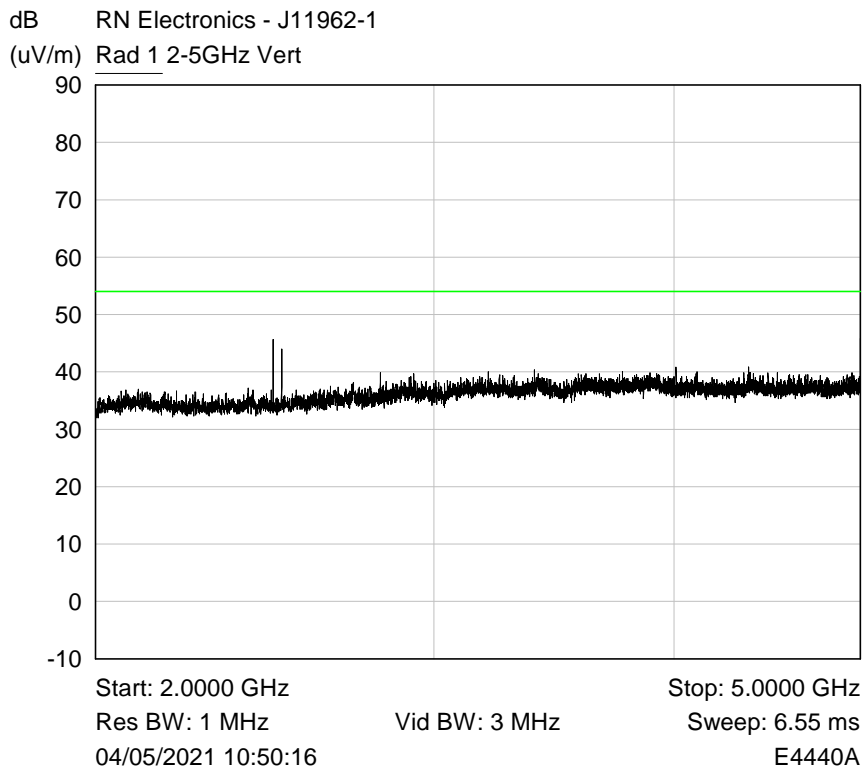
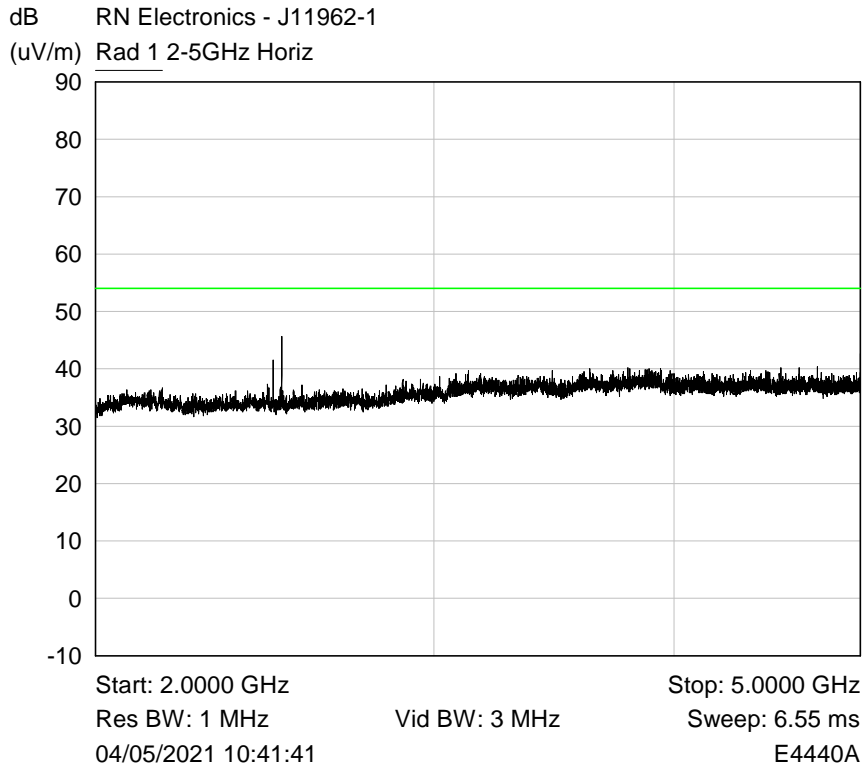

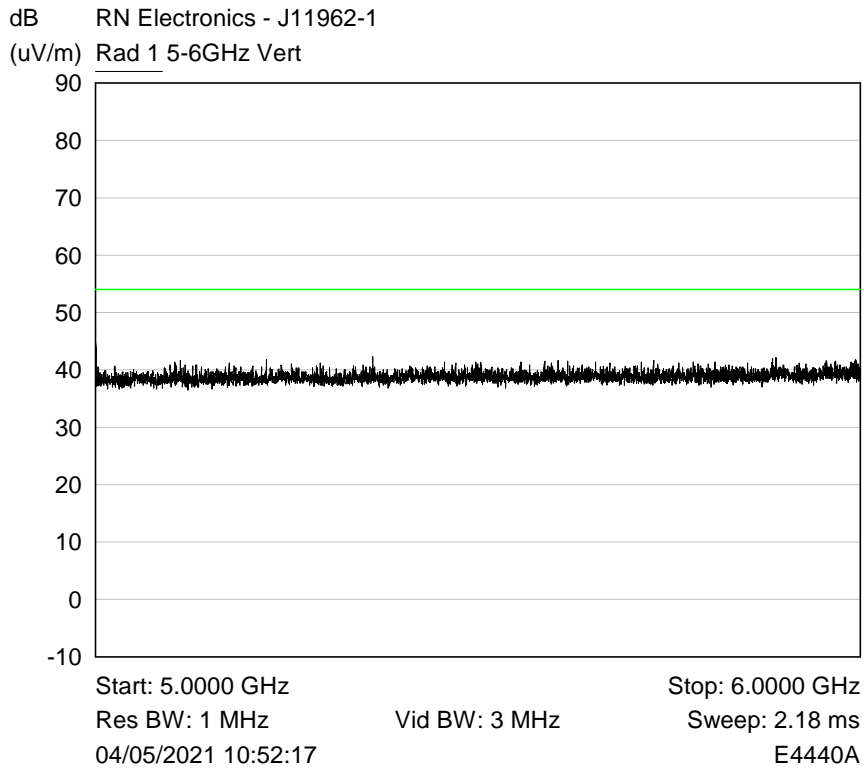
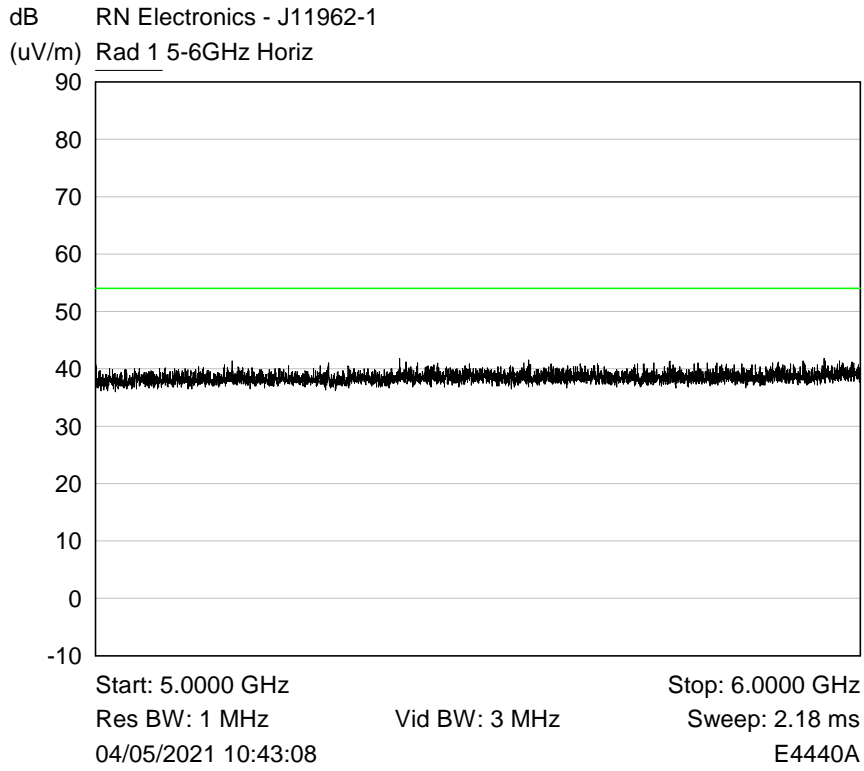

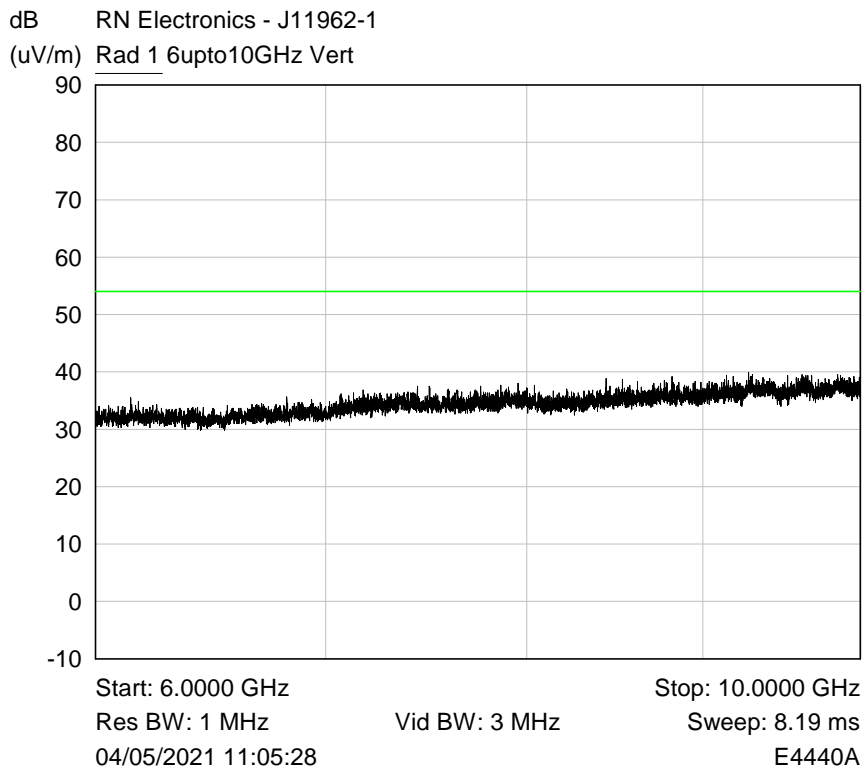
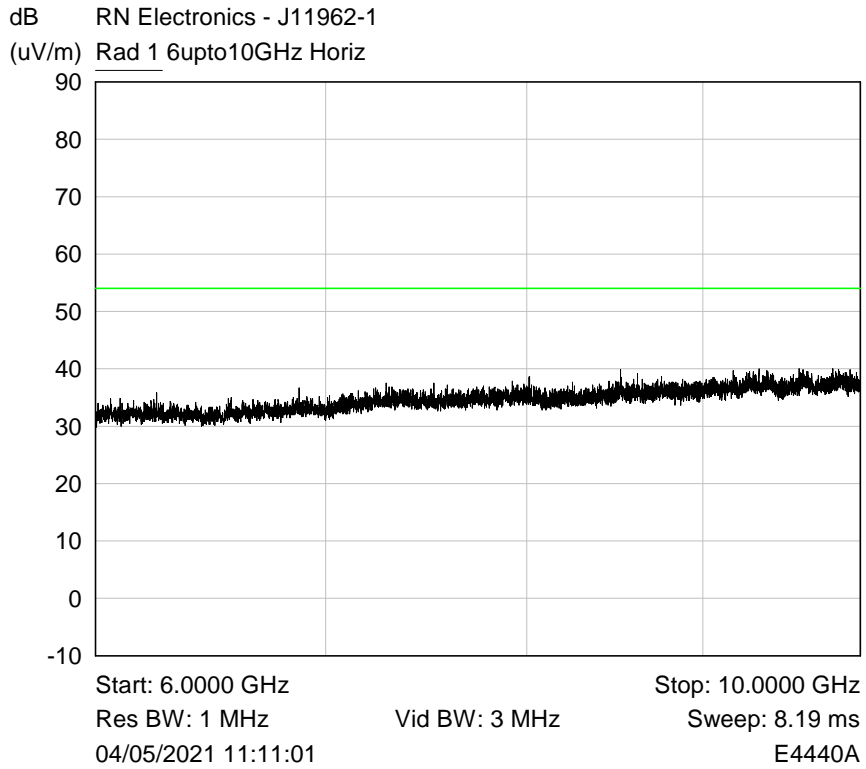

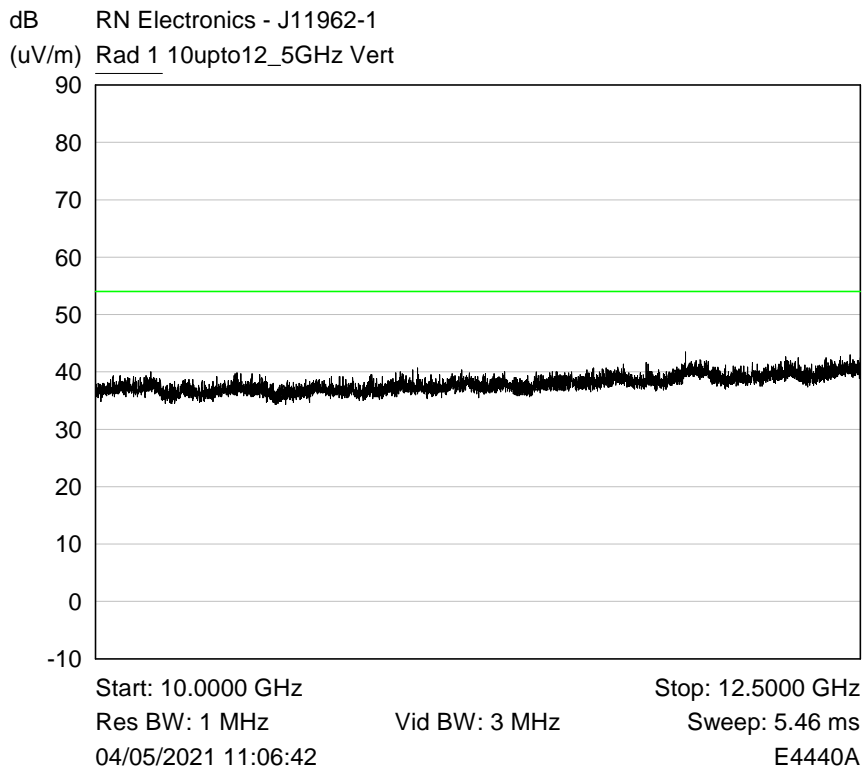
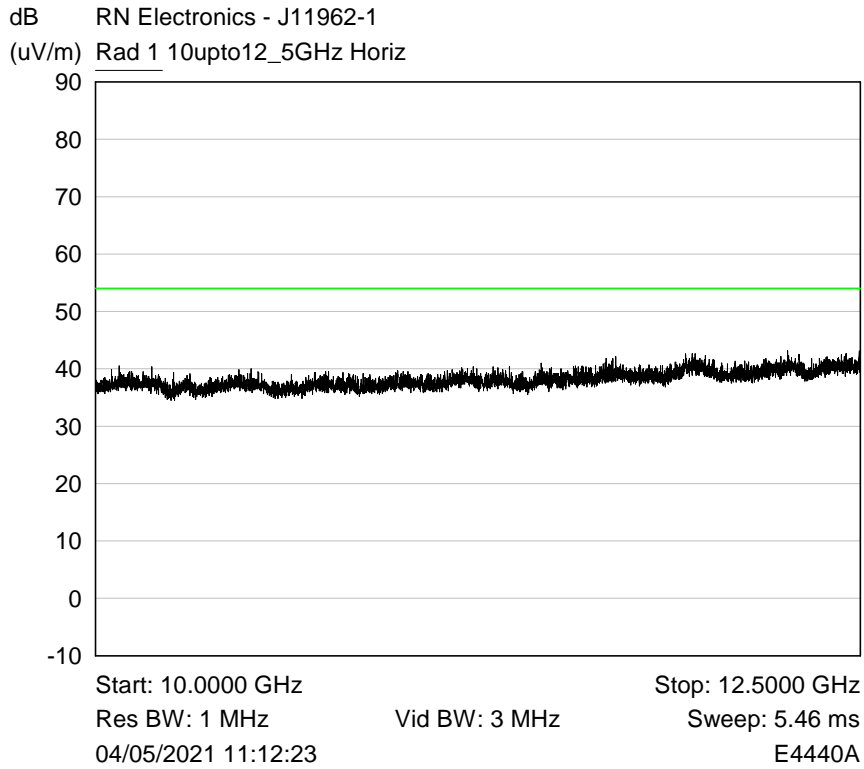

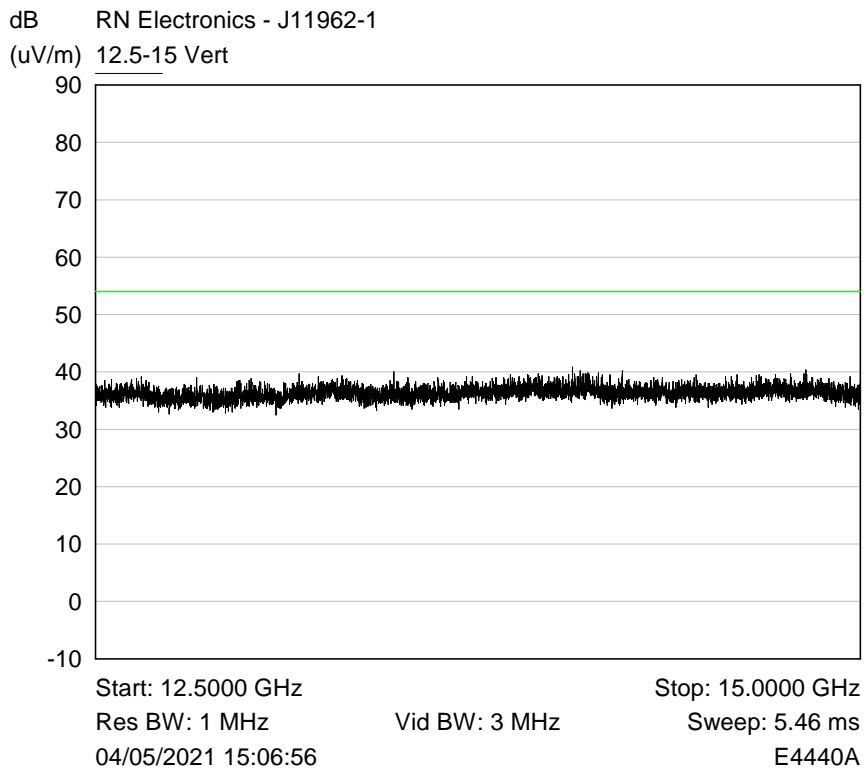
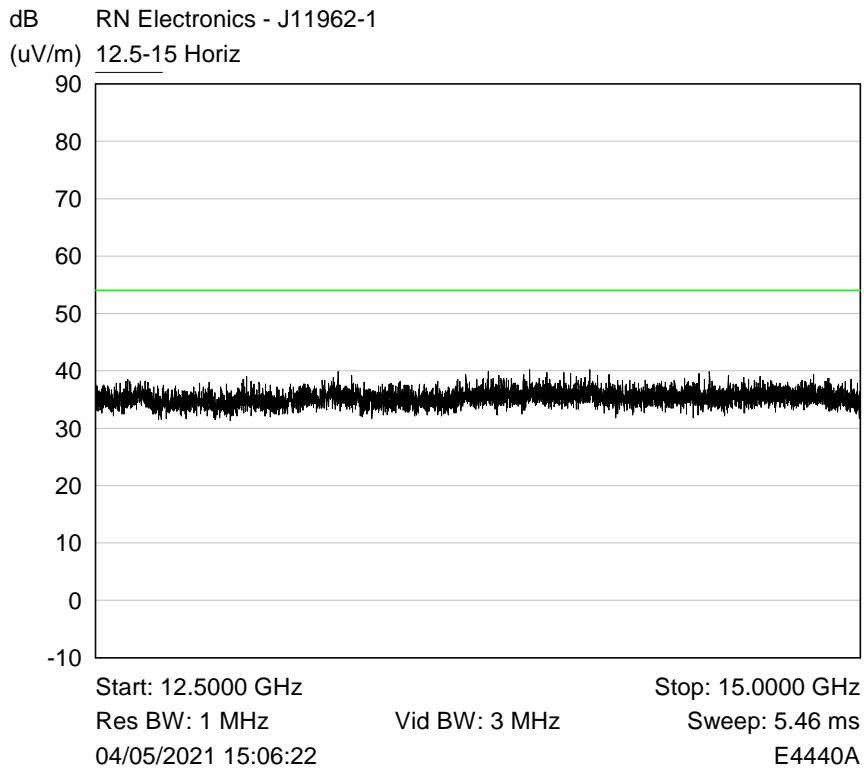

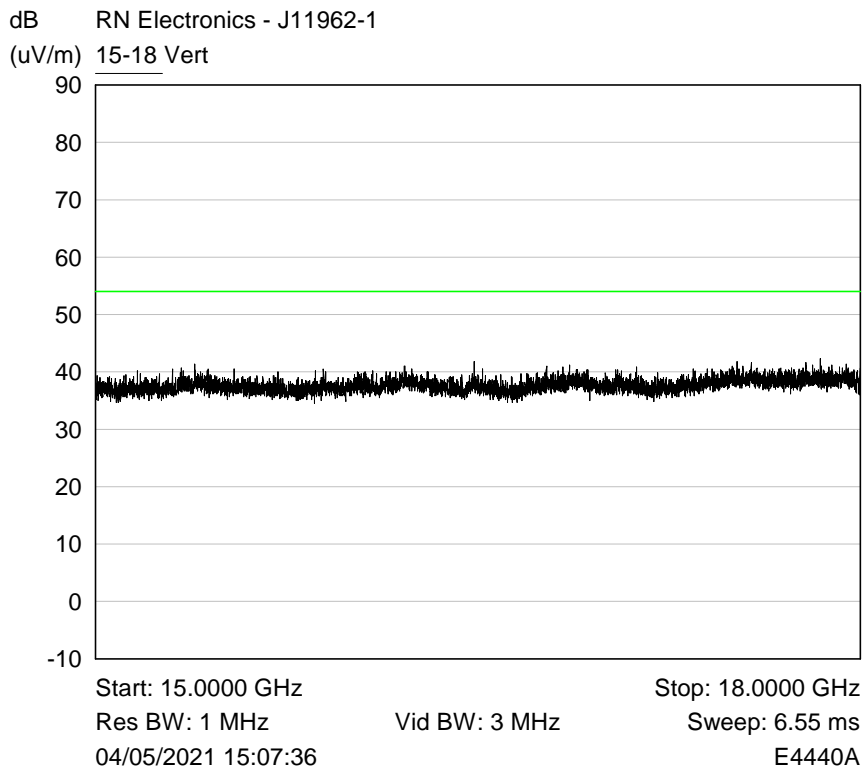
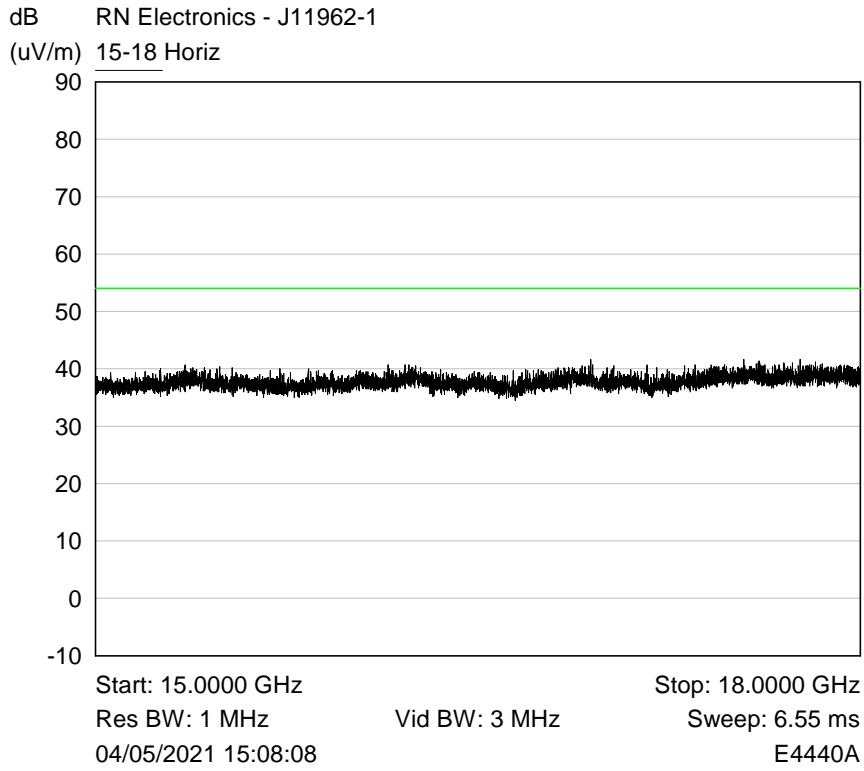

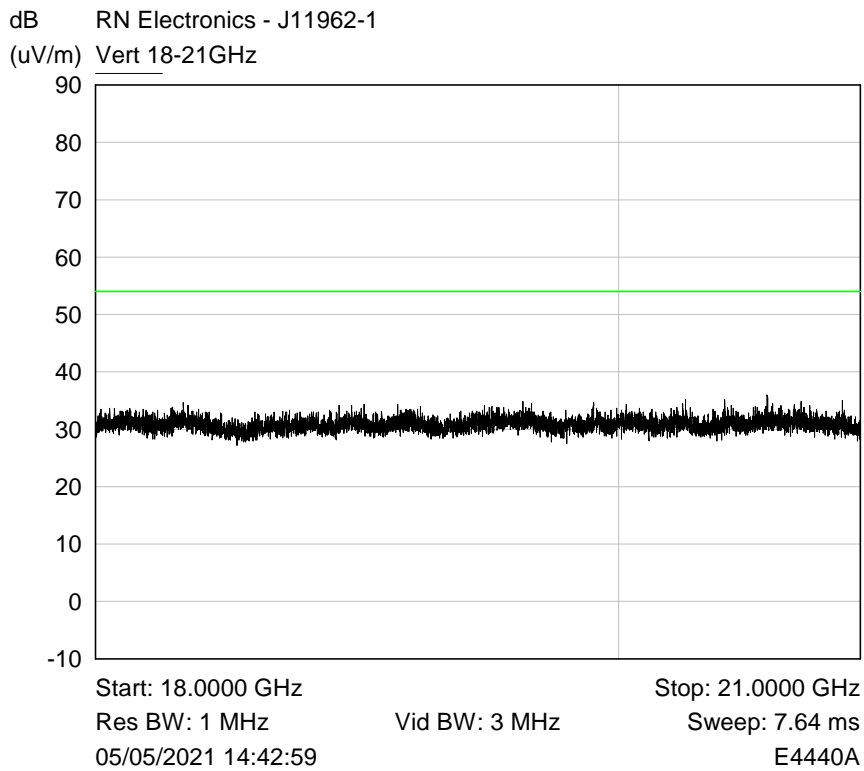
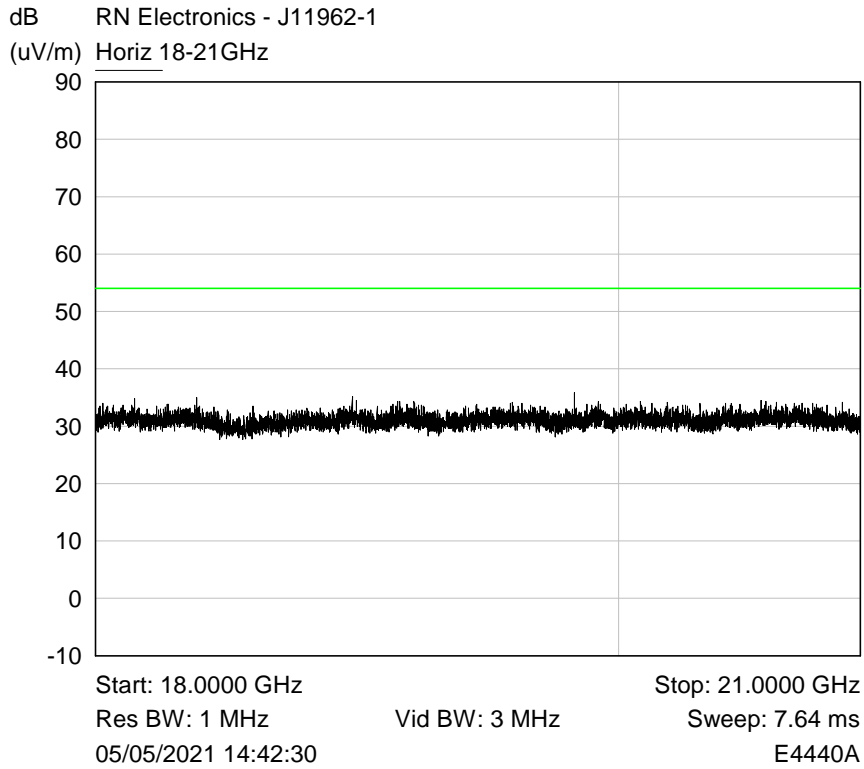

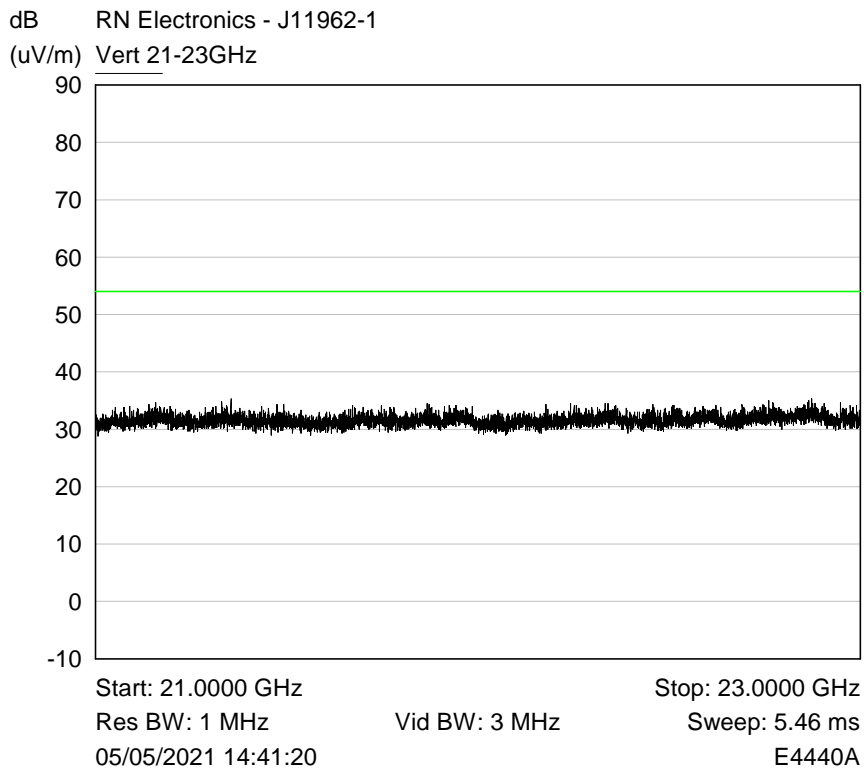
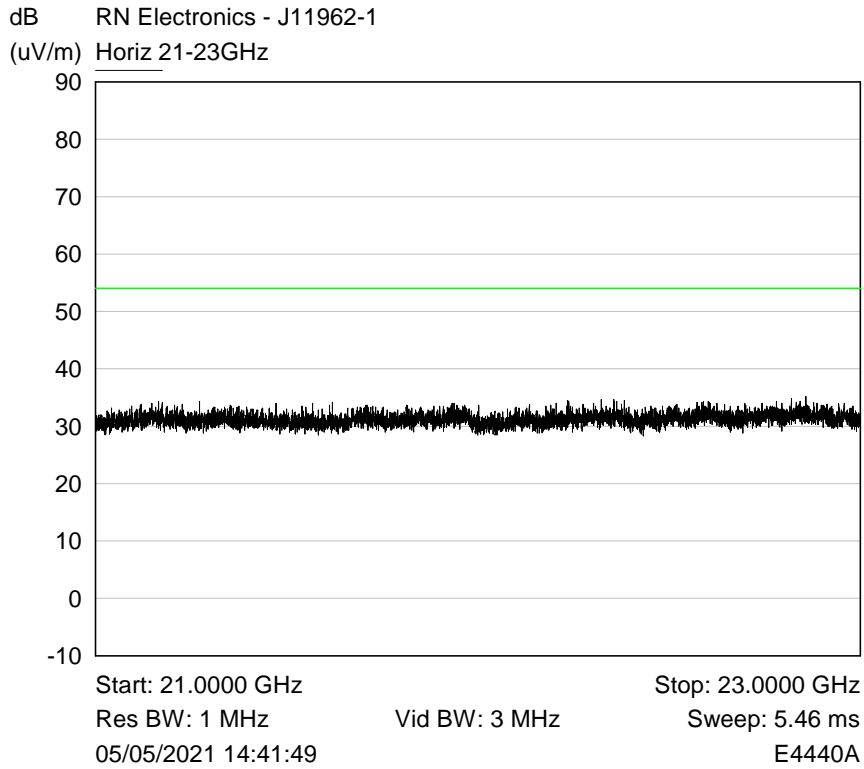

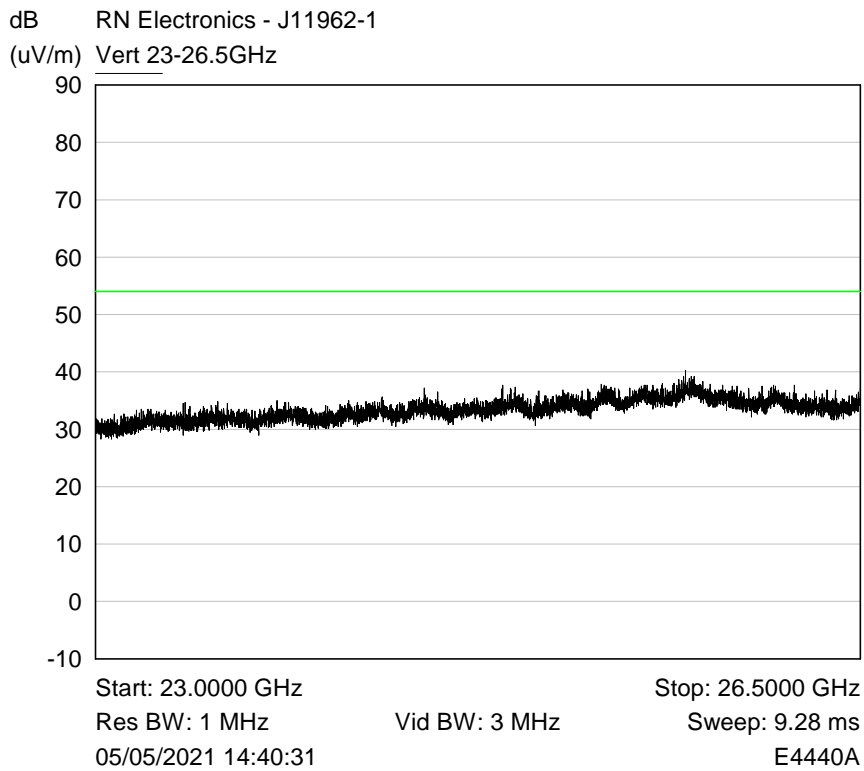
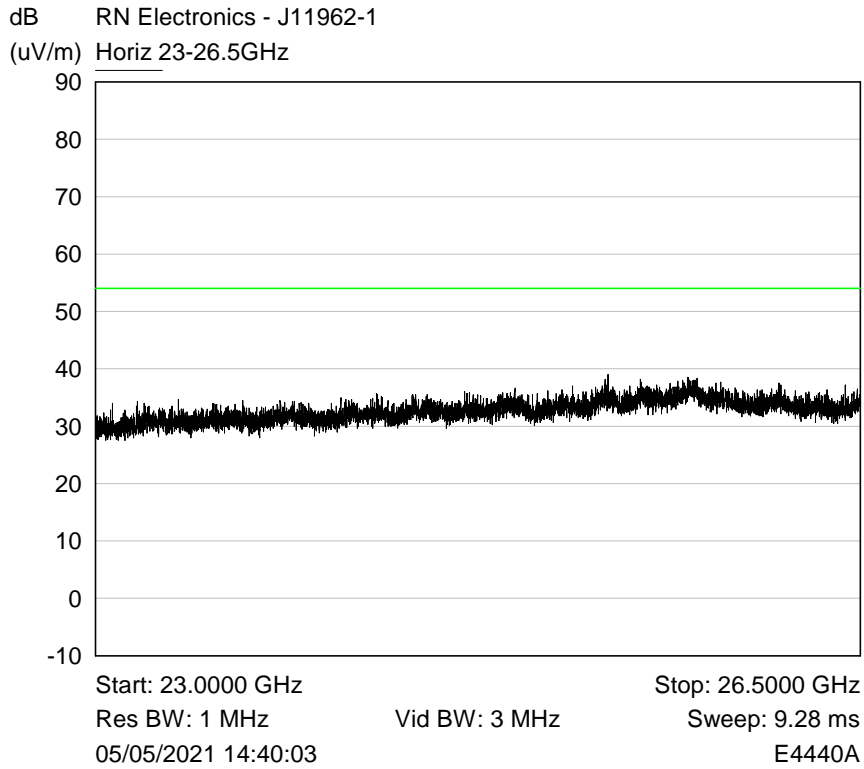

7 Explanatory Notes

7.1 Explanation of Table of Signals Measured

Measurements are made as required by the standard. These measurements are made and recorded using detectors, either peak, quasi peak or average dependant on the test. A table of results has been given following the relevant plots. This table looks similar to the one illustrated below dependant on the measurements required by the test: -

Signal No.	Freq (MHz)	Peak Amp (dB μ V)	Pk – Lim 1 (dB)	QP Amp (dB μ V)	QP - Lim1 (dB)	Av Amp (dB μ V)	Av - Lim1 (dB)
1	12345	54.9	-10.5	48	-12.6	37.6	-14.4

Column One - Labelled Signal No. is an incremental number that the receiver has given to each signal that has been measured.

Column Two - Labelled Freq (MHz) is the approximate frequency of the signal received.

Column Three - Labelled Peak Amp (dB μ V) is the level of received signal that was measured in dB above 1 μ V using the peak detector.

Column Four - Labelled Pk - Lim1 (dB) is the difference in level from the peak signal given to the active limit line. If this column appears in the table the peak detector measurement is required by the standard for this test. The results entered in this column indicate the signal level relative to the compliance limit required. Negative numbers indicate that the product is compliant.

Column Five - Labelled QP Amp (dB μ V) is the level of received signal that was measured in dB above 1 μ V using the quasi-peak detector.

Column Six - Labelled QP - Lim1 (dB) is the difference in level from the quasi-peak signal given to the active limit line. If this column appears in the table the quasi-peak detector measurement is required by the standard for this test. The results entered in this column indicate the signal level relative to the compliance limit required. Negative numbers indicate that the product is compliant.

Column Seven - Labelled Av Amp (dB μ V) is the level of received signal that was measured in dB above 1 μ V using the average detector.

Column Eight - Labelled Av - Lim1 (dB) is the difference in level from the average signal given to the active limit line. If this column appears in the table the average detector measurement is required by the standard for this test. The results entered in this column indicate the signal level relative to the compliance limit required. Negative numbers indicate that the product is compliant.

Only signals highlighted in red are deemed to exceed the limit of the detector required.

7.2 Explanation of limit line calculations for radiated measurements

The limits given in the test standard are normally expressed as absolute values (e.g. in μ V/m at a specified distance), whereas the measured values are expressed as peak, quasi peak or average values in dB μ V/m referenced to the measuring instrument inputs. RN Electronics calibrate the test set-up to account for any path losses, antenna gains, etc. so that the value read at the receiver relates directly to the absolute value required, except that it is expressed in dB relative to one microVolt and may need to take account of any alternative measuring distance used. Examples:

(a) limit of 500 μ V/m equates to $20.\log(500) = 54$ dB μ V/m.

(b) limit of 300 μ V/m at 10m equates to $20.\log(300 \cdot 10/3) = 60$ dB μ V/m at 3m

(c) limit of 30 μ V/m at 30m, but below 30MHz, equates to $20.\log(30) + 40.\log(30/3) = 69.5$ dB μ V/m at 3m, as extrapolation factor below 30MHz is 40dB/decade per $15.31(f)(2)$.

File Name: Cambridge Communication Systems Ltd.11962-1 Issue 02

QMF21J - Issue 05 - RNE Issue 03; 47 CFR Part 15C 2019

The measurement receiver used for emissions testing, performs the field strength (FS) calculations automatically. The receiver combines the signal amplitude (RA), Antenna Factor (AF) and Cable Loss (CL) factors for the frequency to be measured.

Example calculation: - FS = RA + AF + CL.

Receiver amplitude (RA)	Antenna factor (3m) (AF)	Cable loss (CL)	Field strength result (3m) (FS)
20dBuV	25 dB	3 dB	48dBuV/m

Additional calculation examples per ANSI C63.10 clause 9.4 – 9.6 equations 21, 22, 25 & 26:

Equation 21: $E_{Linear} = 10^{((E_{Log} - 120)/20)}$

And therefore equation 21 transposed is: $E_{Log} = 20 \times \text{Log}(E_{Linear}) + 120$

Where:

E_{Linear} is the field strength of the emission in V/m

E_{Log} is the field strength of the emissions in dBμV/m

Equation 22: $E_{IRP} = E_{Meas} + 20 \log(d_{Meas}) - 104.7$

Where:

EIRP is equivalent isotropically radiated power in dBm

E_{Meas} is the field strength of the emission at the measurement distance in dBμV/m

d_{Meas} is the measurement distance in metres

Equation 25: $PD = E_{IRP_{Linear}} / 4\pi d^2$

And therefore equation 25 transposed is: $E_{IRP_{Linear}} = PD \times 4\pi d^2$

Where:

PD is the power density at distance specified by the limit, in W/m²

$E_{IRP_{Linear}}$ is the equivalent isotropically radiated power in Watts

d is the distance at which the power density limit is specified in metres

Equation 26: $PD = E_{Spec\ limit}^2 / 377$

And therefore equation 26 transposed is: $E_{Spec\ limit} = \sqrt{(PD \times 377)}$

Where:

PD is the power density at distance specified by the limit, in W/m²

$E_{Spec\ limit}$ is the field strength at the distance specified by the limit in V/m

Example:

Radiated spurious emissions limit at 3metres of 90pW/cm².

$90\text{pW/cm}^2 \times 100^2 = 0.9 \mu\text{W/m}^2 = (\text{EIRP Linear})$

Equation 25 transposed: $0.9 \times 10^{-6} \times 4 \times \pi \times 3^2 = 0.0001017876 \text{ W}$

And

Equation 26 transposed: $E_{Spec\ limit} = \sqrt{(0.9 \times 10^{-6} \times 377)} = 0.01842 \text{ V/m.}$

And

Equation 21 transposed: $E_{Log} = 20 \text{Log}(0.01842) + 120 = 85.3 \text{dB}\mu\text{V/m} @ 3\text{m.}$

8 Photographs

8.1 EUT Front View

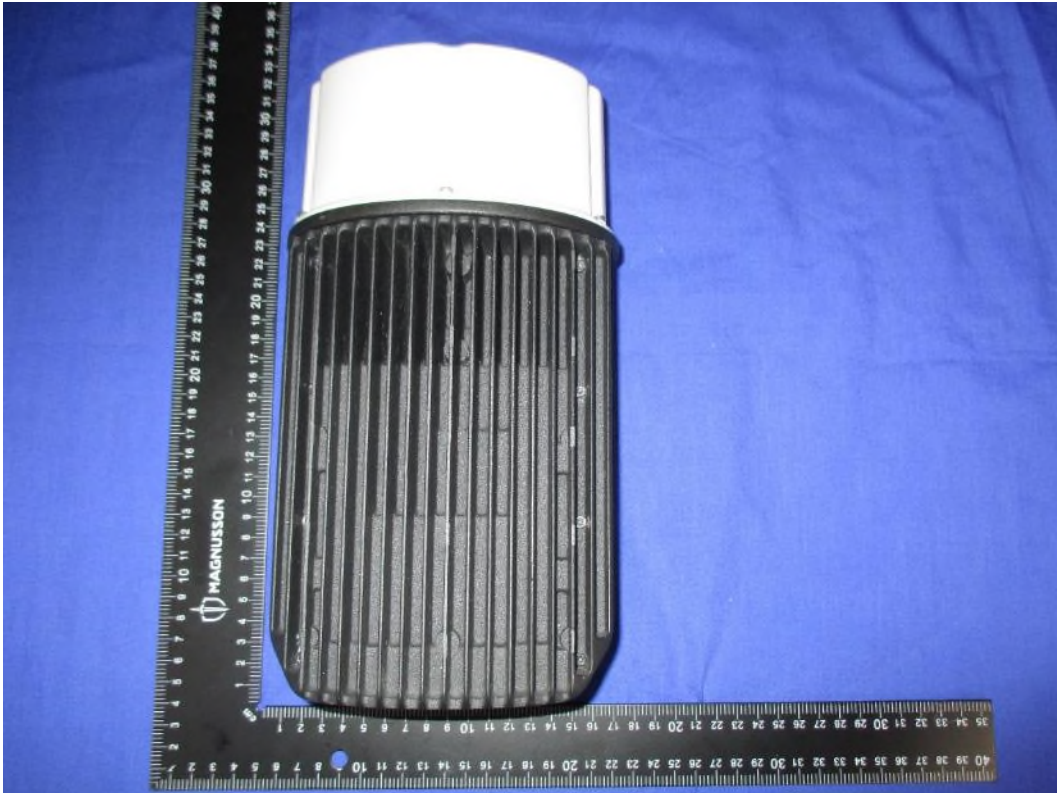

8.2 EUT Reverse Angle

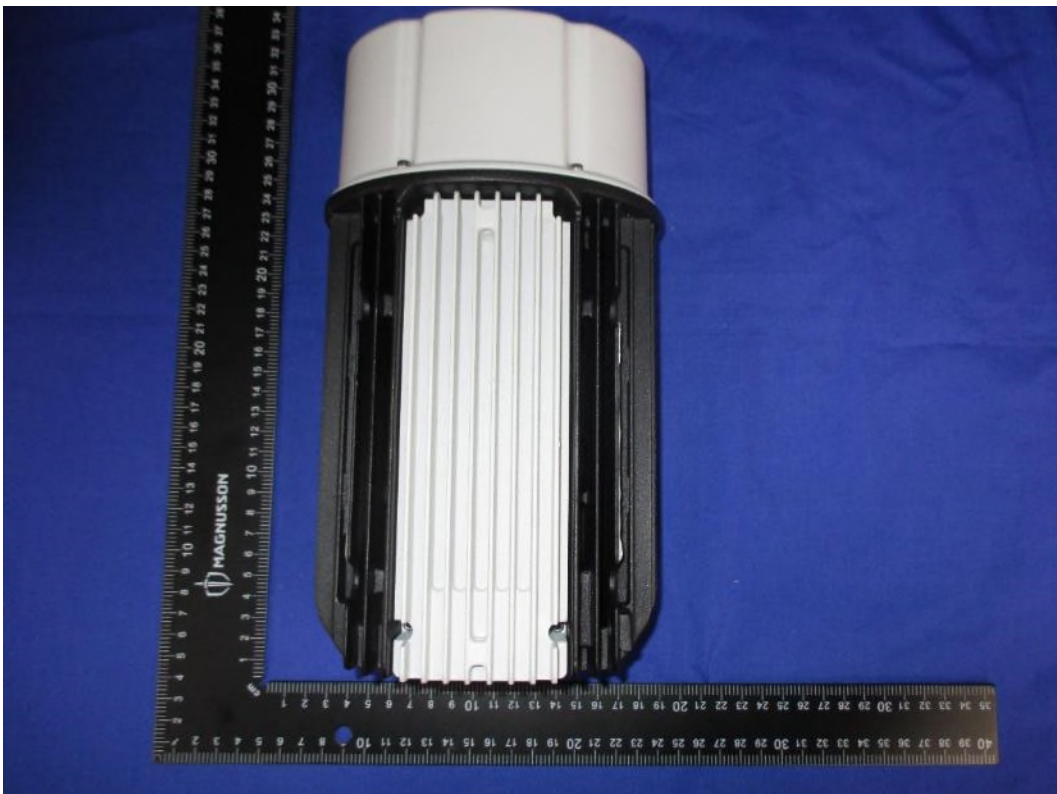

8.3 EUT Left side View



8.4 EUT Right side View



8.5 EUT Antenna Port

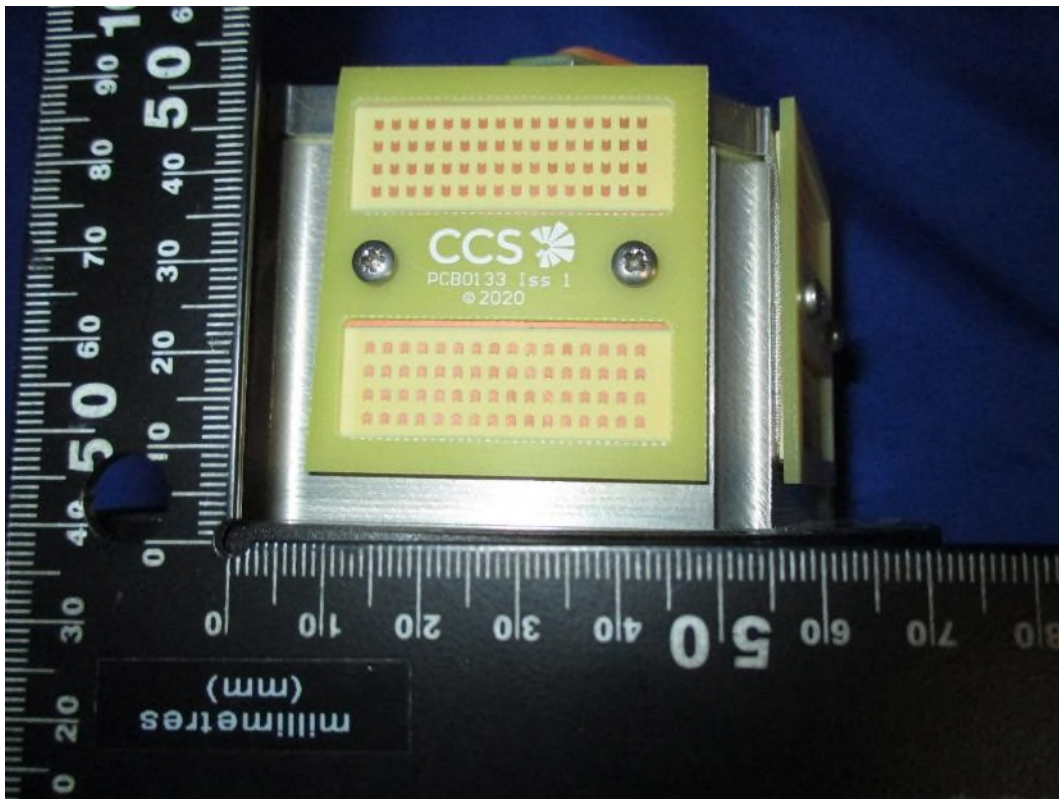

8.6 EUT Display & Controls



8.7 EUT Internal photos

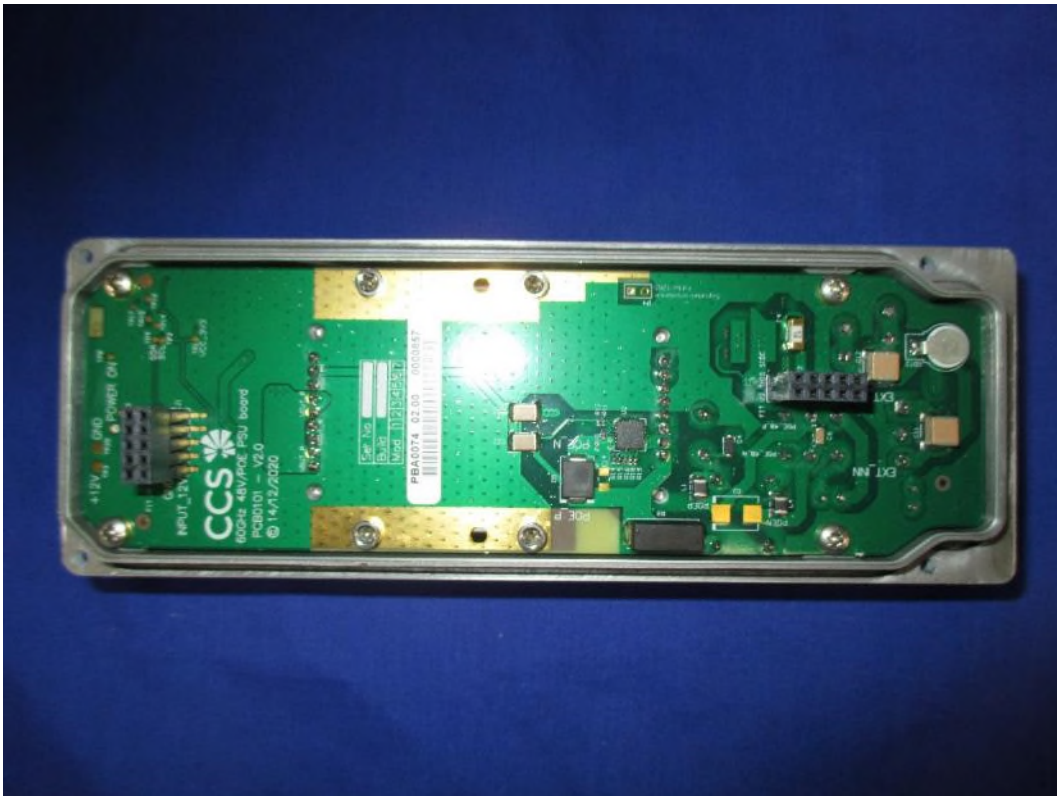

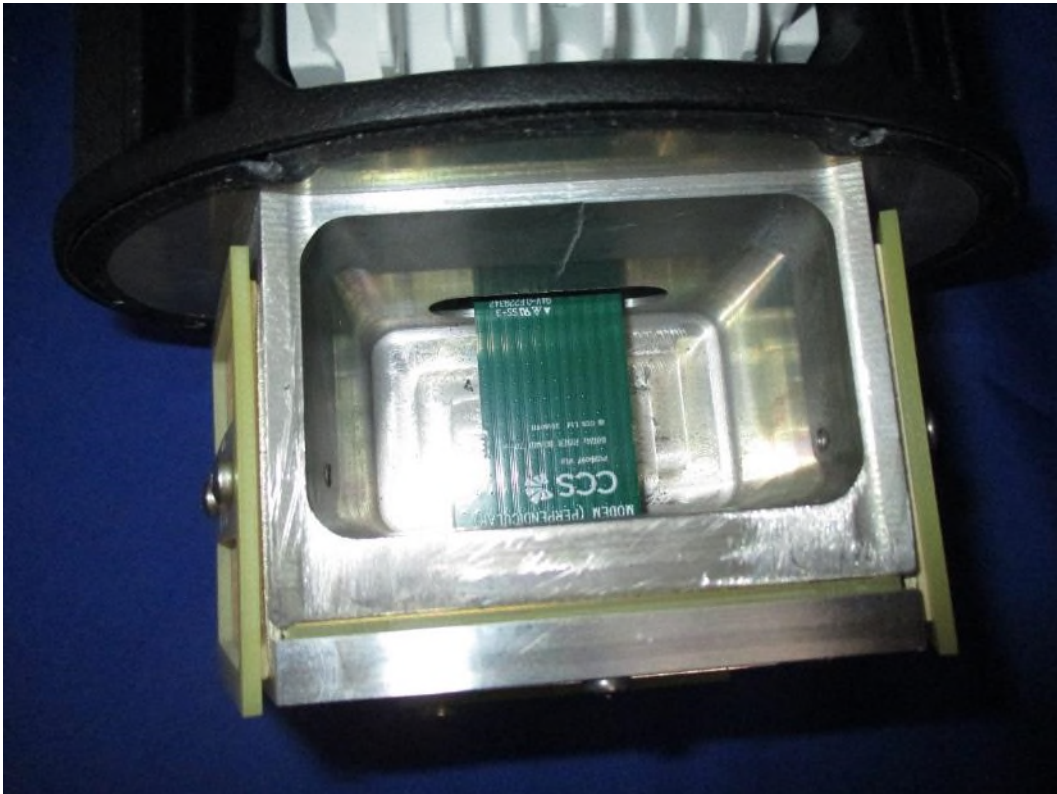
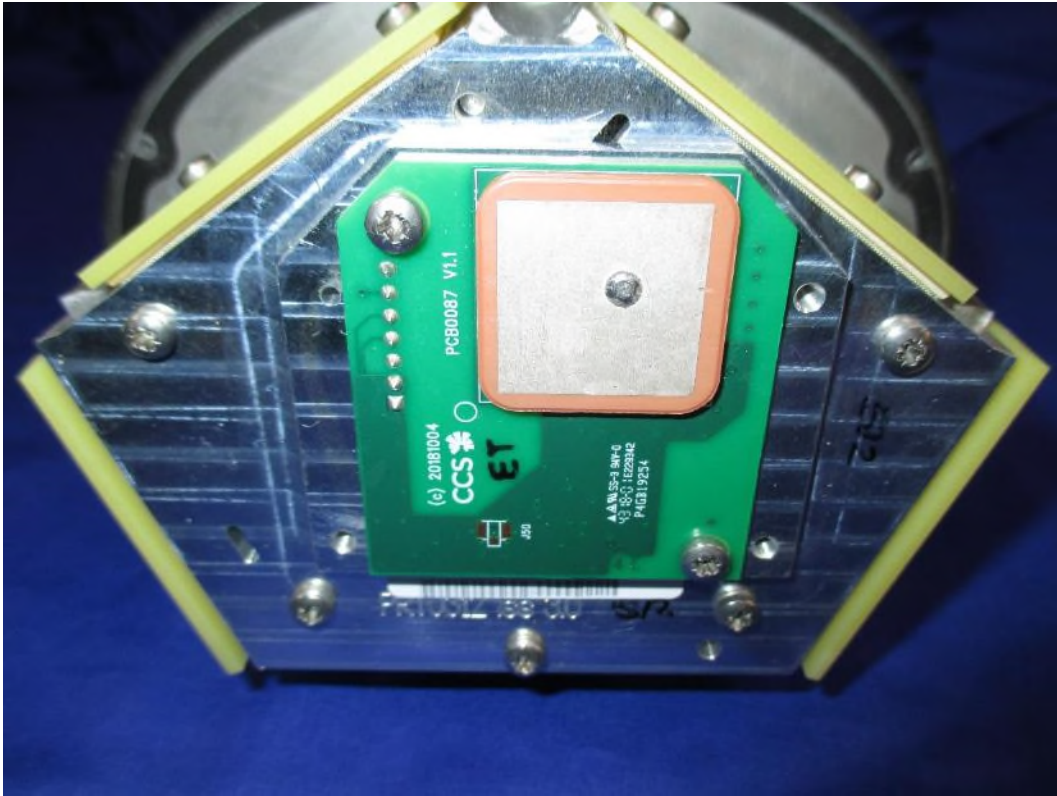

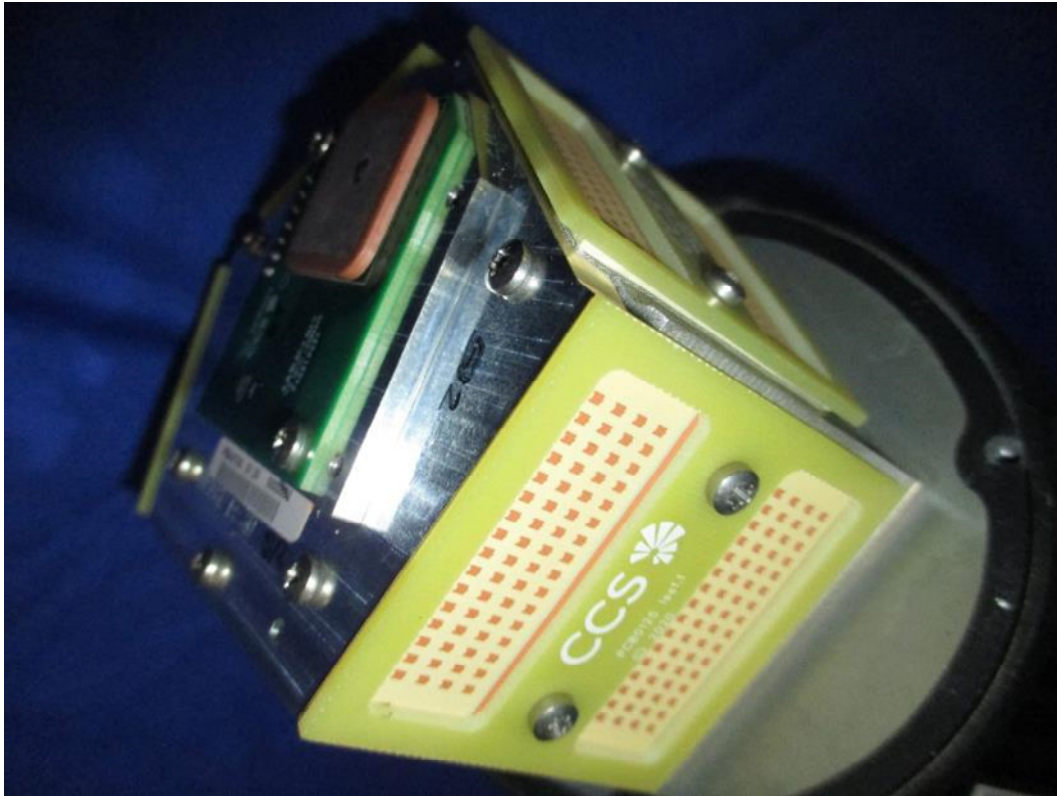

8.8 EUT ID Label



Product Code on label is incorrect. Product Code = G60UM010000

8.9 Radiated emissions 150 kHz - 30 MHz

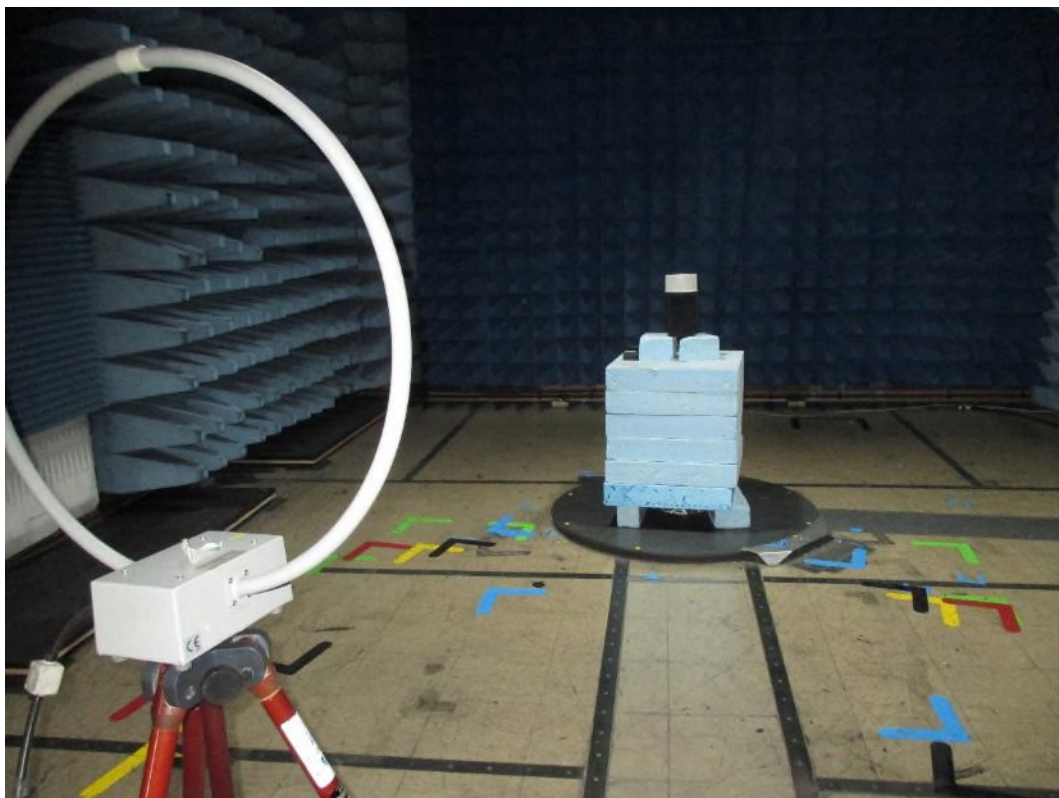

8.10 Radiated emissions 30 MHz -1 GHz

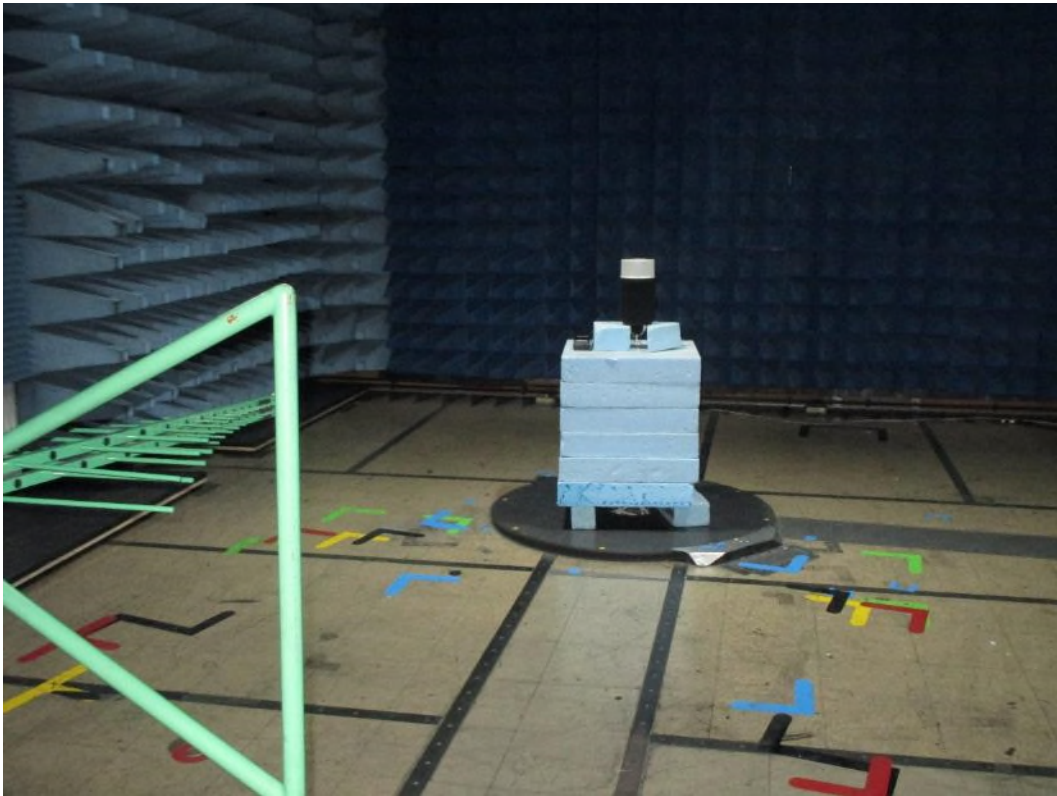



8.11 Radiated emissions above 1 GHz

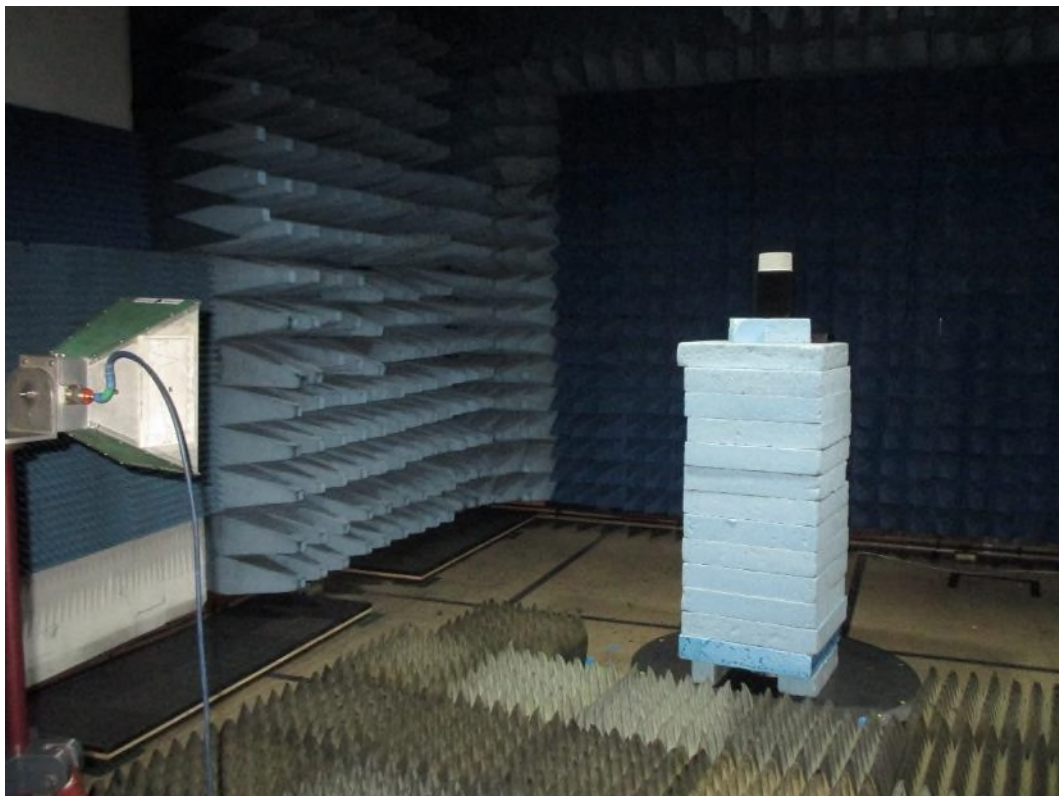

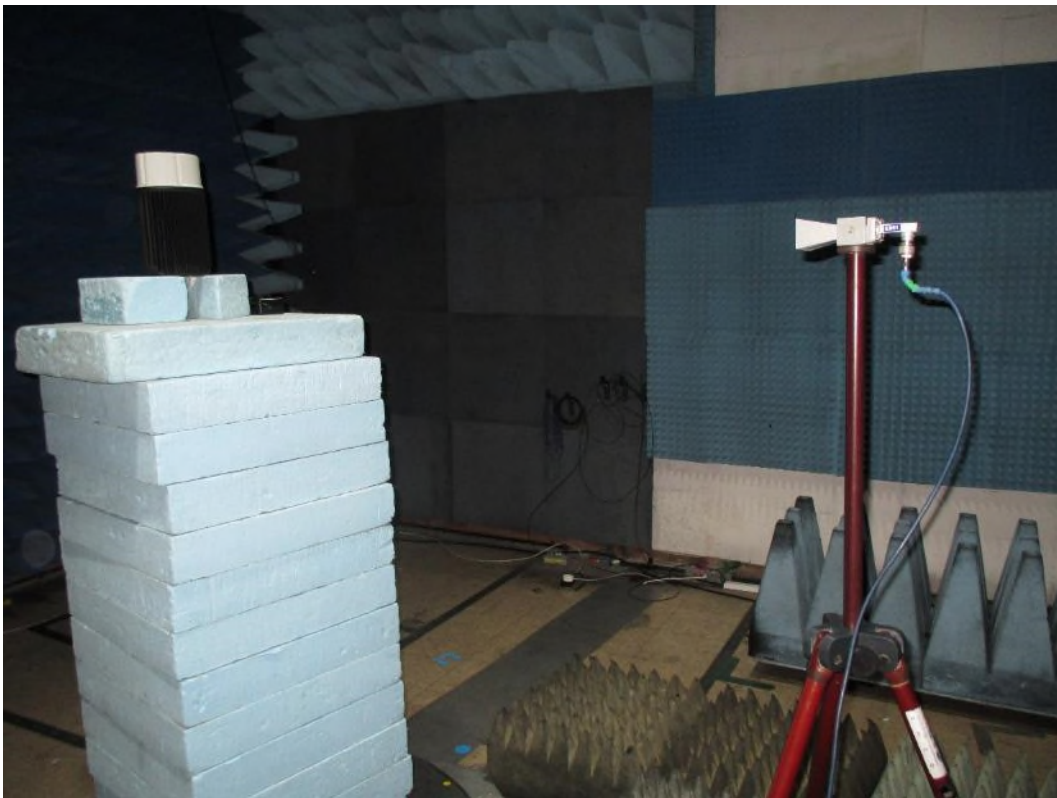
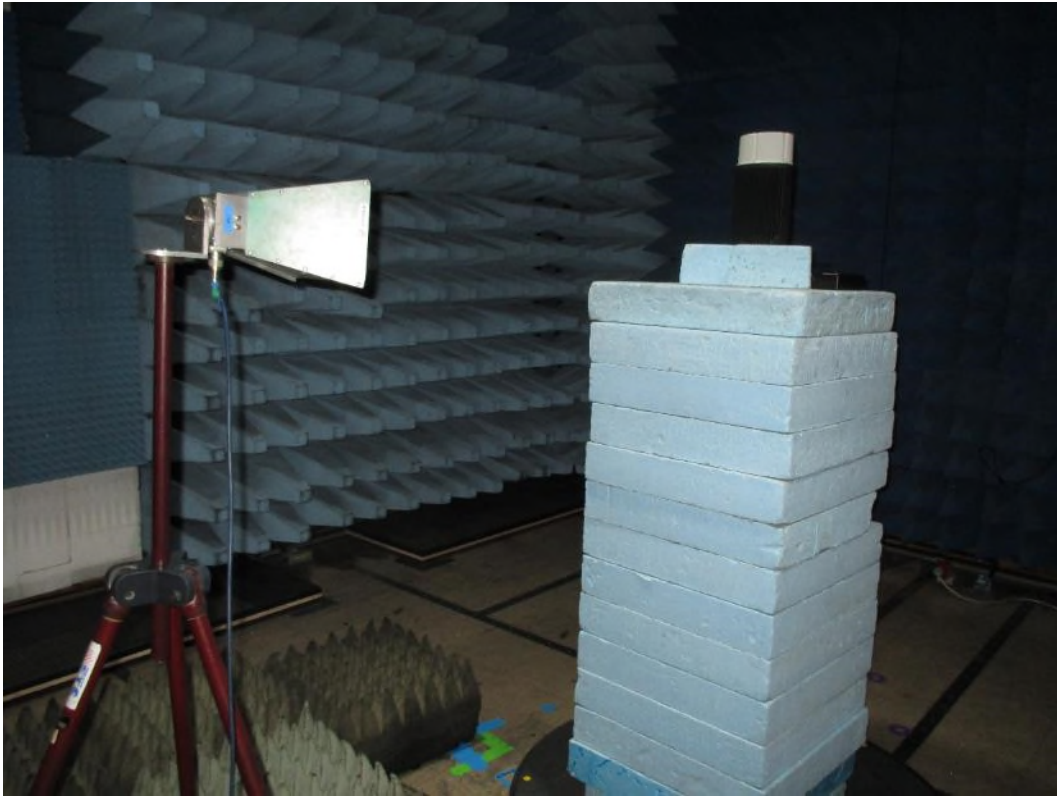



8.12 Radiated emission diagrams

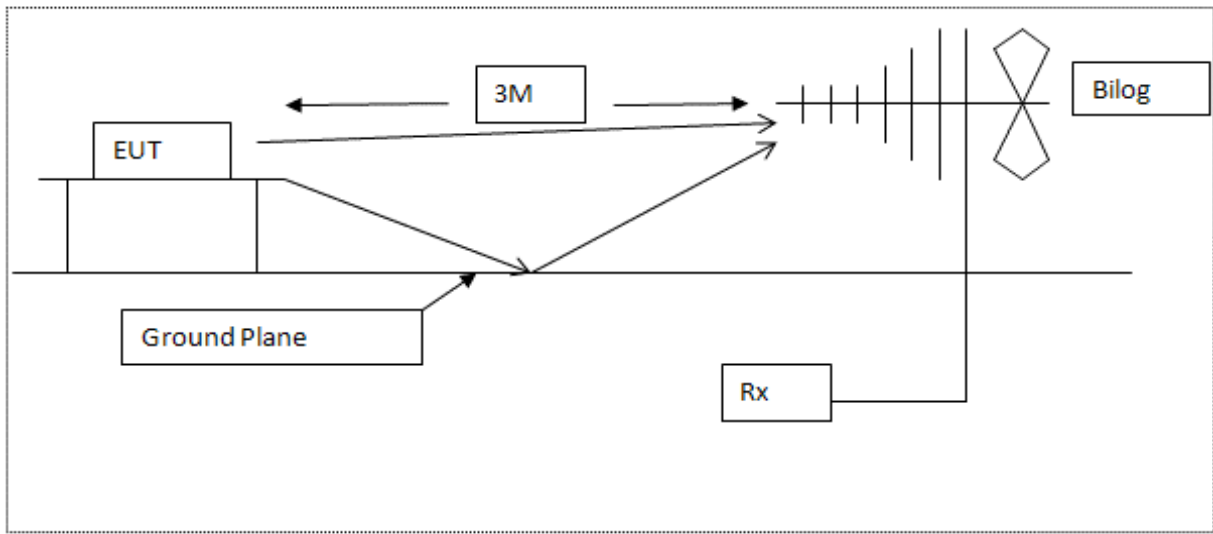

Diagram of the radiated emissions test setup 30 - 1000 MHz

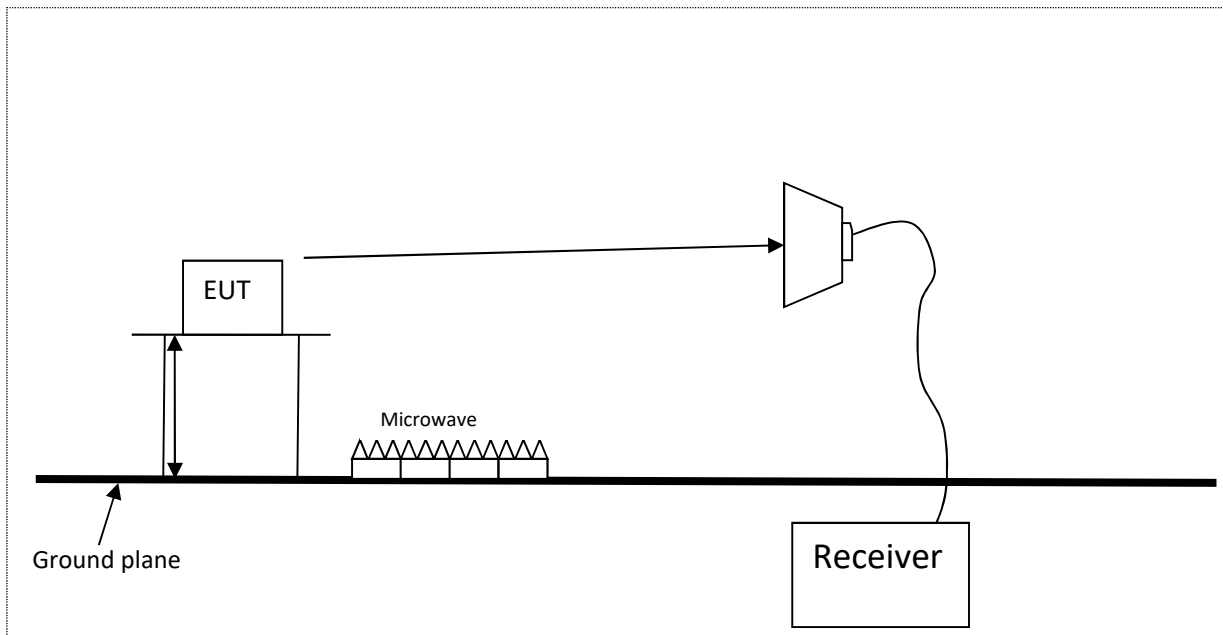

Diagram of the radiated emissions test setup above 1GHz

8.13 AC powerline conducted emission diagram

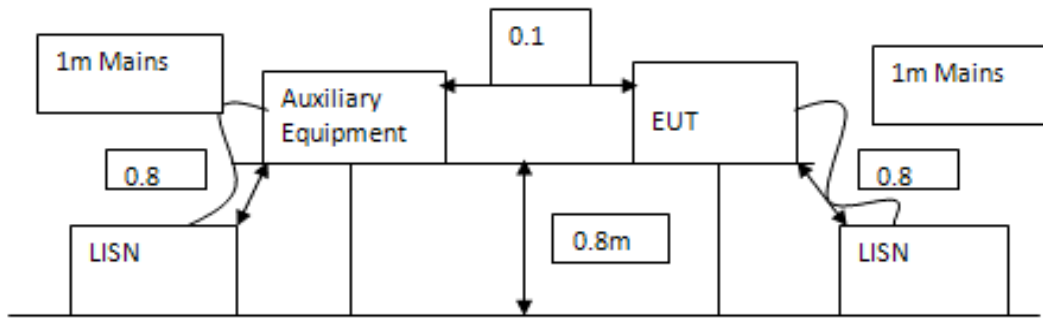

Diagram of the AC conducted emissions test setup

9 Test equipment calibration list

The following is a list of the test equipment used by R.N. Electronics Ltd to test the unit detailed within this report. In line with our procedures, the equipment was within calibration for the period during which testing was carried out.

RN No.	Model No.	Description	Manufacturer	Calibration date	Cal period
E136	3105	Horn Antenna 1 - 12.5 GHz	EMCO	10-Apr-2021	12 months
E404	2024-20	Horn Std Gain 17.6-26.7GHz	Flann (FMI)	25-Aug-2020	12 months
E411	N9039A	9 kHz - 1 GHz RF Filter Section	Agilent Technologies	11-Jul-2020	12 months
E624	E4440A	PSA 3 Hz - 26.5 GHz	Agilent Technologies	11-Jul-2020	24 months
E743	2017 4/2dB	Attenuator 4/2dB 30-1000MHz	RN Electronics	06-Feb-2021	12 months
LPE364	CBL6112A	Antenna BiLog 30MHz - 2GHz	Chase Electronics Ltd	07-Mar-2020	24 months
NSA-M	NSA - M	NSA - Site M	RN Electronics	09-Jan-2019	36 months
TMS78	3160-08	Horn Std Gain 12.4-18 GHz	ETS Systems	25-Aug-2020	12 months
TMS81	6502	Antenna Active Loop	EMCO	24-Jun-2019	24 months
ZSW1	V2.4	Measurement Software Suite	RN Electronics	Not Applicable	

10 Auxiliary and peripheral equipment

10.1 Customer supplied equipment

Item No.	Model No.	Description	Manufacturer	Serial No.
1	Latitude 5410	Laptop and power supply	Dell	CCSLT09-RFLab09

10.2 RN Electronics supplied equipment

RN No.	Model No.	Description	Manufacturer	Serial No
N623	STD-48025	PSU 48V 2.5A 120/240Vac	TT Electronics	-

11 Condition of the equipment tested

In order for the EUT to produce the results shown within this report the following modifications, if any, were implemented.

11.1 Modifications before test

No modifications were made before test by RN Electronics Ltd.

11.2 Modifications during test

No modifications were made during test by RN Electronics Ltd.

12 Description of test sites

Site A	Radio Laboratory and Anechoic Chamber
Site B	Semi-Anechoic Chamber and Control Room FCC Registration No. 293246, ISED Registration No. 5612A-4
Site C	Transient Laboratory
Site D	Screened Room (Conducted Immunity)
Site E	Screened Room (Control Room for Site D)
Site F	Screened Room (Conducted Emissions)
Site G	Screened Room (Control Room for Site H)
Site H	3m Semi-Anechoic Chamber (indoor OATS) FCC Registration No. 293246, ISED Registration No. 5612A-2, VCCI Registration No. 4065
Site J	Transient Laboratory
Site K	Screened Room (Control Room for Site M)
Site M	3m Semi-Anechoic Chamber (indoor OATS) FCC Registration No. 293246, ISED Registration No. 5612A-3
Site N	Radio Laboratory
Site Q	Fully-Anechoic Chamber
Site OATS 3m and 10m Open Area Test Site	FCC Registration No. 293246, ISED Registration No. 5612A-1
Site R	Screened Room (Conducted Immunity)
Site S	Safety Laboratory
Site T	Transient Laboratory

RN Electronics CAB identifier as issued by Innovation, Science and Economic Development Canada is UK0002.

RN Electronics CAB identifier as issued by FCC is UK0015.

13 Abbreviations and units

%	Percent	LBT	Listen Before Talk
µA/m	microAmps per metre	LO	Local Oscillator
µV	microVolts	mA	milliAmps
µW	microWatts	max	maximum
AC	Alternating Current	kPa	Kilopascal
ALSE	Absorber Lined Screened Enclosure	Mbit/s	MegaBits per second
AM	Amplitude Modulation	MHz	MegaHertz
Amb	Ambient	mic	Microphone
ATPC	Automatic Transmit Power Control	min	minimum
BER	Bit Error Rate	mm	milliMetres
°C	Degrees Celsius	ms	milliSeconds
C/I	Carrier / Interferer	mW	milliWatts
CEPT	European Conference of Postal and Telecommunications Administrations	NA	Not Applicable
COFDM	Coherent OFDM	nom	Nominal
CS	Channel Spacing	nW	nanoWatt
CW	Continuous Wave	OATS	Open Area Test Site
dB	deciBels	OFDM	Orthogonal Frequency Division Multiplexing
dBµA/m	deciBels relative to 1µA/m	ppm	Parts per million
dBµV	deciBels relative to 1µV	PRBS	Pseudo Random Bit Sequence
dBc	deciBels relative to Carrier	QAM	Quadrature Amplitude Modulation
dBm	deciBels relative to 1mW	QPSK	Quadrature Phase Shift Keying
DC	Direct Current	R&TTE	Radio and Telecommunication Terminal Equipment
DTA	Digital Transmission Analyser	Ref	Reference
EIRP	Equivalent Isotropic Radiated Power	RF	Radio Frequency
ERP	Effective Radiated Power	RFC	Remote Frequency Control
EU	European Union	RSL	Received Signal Level
EUT	Equipment Under Test	RTP	Room Temperature and Pressure
FM	Frequency Modulation	RTPC	Remote Transmit Power Control
FSK	Frequency Shift Keying	Rx	Receiver
g	Grams	s	Seconds
GHz	GigaHertz	SINAD	Signal to Noise And Distortion
Hz	Hertz	Tx	Transmitter
IF	Intermediate Frequency	V	Volts
kHz	kiloHertz		