

Produkte
Products

Prüfbericht - Nr.: 50006140 001		Seite 1 von 26	
<i>Test Report No.:</i>		<i>Page 1 of 26</i>	
Auftraggeber: <i>Client:</i>	New Japan Radio Co., Ltd. 1-1, Fukuoka 2-Chome, Fujimino City Saitama, 356-8510 Japan		
Gegenstand der Prüfung: <i>Test Item:</i>	K-Band Doppler Sensor Module (Movement Sensor)		
Bezeichnung: <i>Identification:</i>	NJR4262F3P5	Serien-Nr.: <i>Serial No.:</i>	A003088A
Wareneingangs-Nr.: <i>Receipt No.:</i>	A000068748	Eingangsdatum: <i>Date of Receipt:</i>	2014-05-13
Zustand des Prüfgegenstandes bei Anlieferung: <i>Condition of Test Item at Delivery:</i>	Good		
Prüfört: <i>Testing Location:</i>	TÜV Rheinland Japan Ltd. – Global Technology Assessment Center 4-25-2 Kita-Yamata, Tsuzuki-ku, Yokohama 224-0021, Japan		
Prüfgrundlage: <i>Test Specification:</i>	FCC 47 CFR Part 15, Subpart C, Sections 15.207, 15.209, 15.215 and 15.245 (October 1, 2013) ANSI C63.10-2009		
Prüfergebnis: <i>Test Result:</i>	Der Prüfgegenstand entspricht oben genannter Prüfgrundlage(n). <i>The test item passed the test specification(s).</i>		
Prüflaboratorium: <i>Testing Laboratory:</i>	TÜV Rheinland Japan Ltd. – Global Technology Assessment Center 4-25-2 Kita-Yamata, Tsuzuki-ku, Yokohama 224-0021, Japan		
geprüft/ tested by:	kontrolliert/ reviewed by:		
2014-12-15	A. Abe / Inspector	2014-12-15	Ralf Meiranke / Reviewer
Datum <i>Date</i>	Name/Stellung <i>Name/Position</i>	Unterschrift <i>Signature</i>	Datum <i>Date</i>
			Name/Stellung <i>Name/Position</i>
			Unterschrift <i>Signature</i>
Sonstiges / Other Aspects:			
NJR4262F3P5 was tested as representative model. NJR4262F3P5 and NJR4262F3P3 are completely identical except for available output connector.			
Abkürzungen:	P(ass) = entspricht Prüfgrundlage	Abbreviations:	P(ass) = passed
	F(ail) = entspricht nicht Prüfgrundlage		F(ail) = failed
	N/A = nicht anwendbar		N/A = not applicable
	N/T = nicht getestet		N/T = not tested
Dieser Prüfbericht bezieht sich nur auf das o.g. Prüfmuster und darf ohne Genehmigung der Prüfstelle nicht auszugsweise vervielfältigt werden. Dieser Bericht berechtigt nicht zur Verwendung eines Prüfzeichens. <i>This test report relates to the a. m. test sample. Without permission of the test center this test report is not permitted to be duplicated in extracts. This test report does not entitle to carry any safety mark on this or similar products.</i>			

Produkte
Products

Prüfbericht - Nr.:
Test Report No.:

50006140 001

Seite 2 von 26
Page 2 of 26

TEST SUMMARY

5.1.1 SUPPLY VOLTAGE REQUIREMENTS

RESULT: PASS

5.1.2 ANTENNA REQUIREMENTS

RESULT: PASS

5.1.3 RESTRICTED BANDS OF OPERATION

RESULT: PASS

5.2.1 RADIATED EMISSIONS OF TRANSMITTER (CARRIER, SPURIOUS AND HARMONICS)

RESULT: PASS

5.2.2 20dB BAND WIDTH

RESULT: PASS

5.3.1 AC POWER LINE CONDUCTED EMISSION OF TRANSMITTER

RESULT: PASS

Contents

1.	GENERAL REMARKS	4
1.1	COMPLEMENTARY MATERIALS	4
2.	TEST SITES	4
2.1	TEST FACILITIES	4
2.2	LIST OF TEST AND MEASUREMENT INSTRUMENTS	5
2.3	MEASUREMENT UNCERTAINTY	6
3.	GENERAL PRODUCT INFORMATION	7
3.1	PRODUCT FUNCTION AND INTENDED USE	7
3.2	SYSTEM DETAILS	7
3.3	CLOCK FREQUENCIES	7
3.4	NOISE SUPPRESSING PARTS	7
4.	TEST SET-UP AND OPERATION MODES	8
4.1	TEST METHODOLOGY	8
4.2	OPERATION MODES	8
4.3	PHYSICAL CONFIGURATION FOR TESTING	8
4.4	TEST SOFTWARE	9
4.5	SPECIAL ACCESSORIES AND AUXILIARY EQUIPMENT	10
4.6	COUNTERMEASURES TO ACHIEVE EMC COMPLIANCE	10
5.	TEST RESULTS RADIO	11
5.1	TECHNICAL REQUIREMENTS	11
5.1.1	<i>Supply Voltage Requirements</i>	<i>11</i>
5.1.2	<i>Antenna Requirements</i>	<i>11</i>
5.1.3	<i>Restricted Bands of Operation</i>	<i>12</i>
5.2	RADIATED MEASUREMENTS	13
5.2.1	<i>Radiated Emissions of Transmitter (Carrier, Spurious and Harmonics)</i>	<i>13</i>
5.2.2	<i>20dB Band Width</i>	<i>18</i>
5.3	AC POWER LINE CONDUCTED MEASUREMENTS	20
5.3.1	<i>AC Power Line Conducted Emission of Transmitter</i>	<i>20</i>
6.	PHOTOGRAPHS OF THE TEST SETUP	22
7.	LIST OF TABLES	26
8.	LIST OF FIGURES	26
9.	LIST OF PHOTOGRAPHS	26

1. General Remarks

1.1 Complementary Materials

There is no attachment to this test report.

2. Test Sites

2.1 Test Facilities

TÜV Rheinland Japan Ltd. – Global Technology Assessment Center
4-25-2 Kita-Yamata, Tsuzuki-ku, Yokohama 224-0021, Japan

The used test equipment is in accordance with CISPR 16 for measurement of radio interference.

The Federal Communications Commission has reviewed the technical characteristics of the radiated and conducted emission facilities and has found these test sites to be in compliance with the requirements of section 2.948 of the FCC rules. The description of the test facility is listed under FCC registration number 299054.

The test facility is accredited by VLAC (member of ILAC) under number VLAC-017 according to ISO/IEC 17025:2005.



TÜV Rheinland Japan Ltd. is accredited by the Federal Communications Commission as a Conformity Assessment Body under Designation Number JP0017 and Test Firm Registration Number 386498.

2.2 List of Test and Measurement Instruments

Table 1: List of Test and Measurement Equipment

Kind of Equipment	Manufacturer	Model Name	Serial Number	Equipment ID	Calibrated until
For AC Power Line Conducted Emission					
Receiver	Rohde & Schwarz	ESU 8	100025	RF-0020	2014-09
LISN	Rohde & Schwarz	ENV216	100276	RF-0016	2014-06
For Transmitter and Receiver Radiated Spurious Emission (below 40GHz)					
Receiver	Rohde & Schwarz	ESU 8	100025	RF-0020	2014-09
Receiver	Rohde & Schwarz	ESU 40	100029	RF-0021	2015-03
RF Selector (10m Chamber)	Toyo Corporation	NS4900	0703-182	RF-0029	2014-11
Loop Antenna with Amplifier, 9kHz-30MHz	Rohde & Schwarz	HFH2-Z2	100139	RF-0048	2015-02
Trilog Antenna No. 2, 30-1000MHz	Schwarzbeck	VULB9168	9168-475	RF-0462	2015-01
10dB Attenuator	Hewlett Packard	8491A 10dB	58354	RF-0314	2014-11
Low Noise Preamplifier, 9kHz-1GHz	TSJ	MLA-10K01-B01-35	1370750	RF-0253	2014-11
Low Pass Filter, DC-1GHz	R&K	LP1000CH3	12104001	RF-0515	2014-11
Horn Antenna, 1-8GHz	Schwarzbeck	BBHA9120D	1059	RF-0553	2015-05
Microwave Preamplifier, 1-8GHz	Toyo Corporation	TPA0108-40	0634	RF-0052	2014-11
Horn Antenna with Preamplifier, 8-18GHz	Toyo Corporation	HAP06-18W	00000025	RF-0065	2014-05
High Pass Filter, 8-18GHz	Micro-Tronics	HPM50107	006	RF-0334	2014-05
Horn Antenna with Preamplifier, 18-26.5GHz	Toyo Corporation	HAP18-26N	00000010	RF-0070	2014-05
Horn Antenna with Preamplifier, 26.5-40GHz	Toyo Corporation	HAP26-40N	00000007	RF-0069	2014-08
Preamplifier, 26.5-40GHz	Toyo Corporation	HAP2640-S	-	RF-0258	2014-11
For Transmitter and Receiver Radiated Spurious Emission (above 40GHz)					
Spectrum Analyzer	Agilent	E4447A	MY48250005	BT-8267	2015-04
Harmonic Mixer 40-60GHz	Agilent	11970U	MY30030222	BT-8348	2015-03
Horn Antenna 40-60GHz (RX)	Custom Microwave Inc.	HO19R	-	BT-8334	N/A
Preselected Mixer 50-75GHz	Agilent	11974VE1	MY30010118	BT-8349	2015-04
Harmonic Mixer 50-75GHz	Agilent	11970V	MY30033072	BT-8367	2015-03

Prüfbericht - Nr.: 50006140 001
Seite 6 von 26
Test Report No.:
Page 6 of 26

Kind of Equipment	Manufacturer	Model Name	Serial Number	Equipment ID	Calibrated until
Horn Antenna 50-75GHz (RX)	Custom Microwave Inc.	HO15R	-	BT-8336	N/A
Harmonic Mixer 75-110GHz	Agilent	11970W	MY25210462	BT-8350	2015-03
Horn Antenna 75-110GHz (RX)	Custom Microwave Inc.	HO10R	-	BT-8338	N/A

Conformance of the used measurement and test equipment with the requirements of ISO/IEC 17025:2005 has been confirmed before testing.

2.3 Measurement Uncertainty

Table 2: Emission Measurement Uncertainty

Measurement Type	Frequency	Uncertainty
AC Power Line Conducted Emission	150kHz - 30MHz	±2.0dB
Radiated Emission	9kHz – 150kHz	±4.0dB
	150kHz - 30MHz	±4.7dB
	30MHz - 1GHz	±4.7dB
	1GHz – 40GHz	±4.7dB
Radiated Emission (MMW)	40GHz - 50GHz	±7.1dB
	50GHz - 75GHz	±7.5dB
	75GHz – 110GHz	±8.3dB

3. General Product Information

3.1 Product Function and Intended Use

The **EUT** (Equipment Under Test) is RF module to be incorporated into a movement sensor based on Doppler effect Radar. The module comprises transmitter and receiver. Since the receiver does not employ a local oscillator, the measurement output signal is derived directly from the different of the emitted and received frequency (homodyne system). Receiver and transmitter can only be operated simultaneously.

3.2 System Details

Specified output power:	Max. +17dBm
Antenna gain:	+10.8dBi
Antenna type:	Patch antenna (printed on PCB)
Antenna mounting type:	Internal
Frequency range:	24.075 – 24.175GHz
Nominal Frequency	24.125GHz
Number of channels:	1 (Fixed)
Modulation type:	No modulation (CW only)
FCC classification:	FDS
Emission designator:	36K9N0N
Rated voltage:	DC 3.3 – 5.5 V
Rated current:	55mA
Protection class:	III
Test voltage:	AC 120V (Representative AC / DC Adapter) DC 5V (for EUT)
Test frequency:	60Hz (Representative AC / DC Adapter)

3.3 Clock Frequencies

Nothing mentioned explicitly.

3.4 Noise Suppressing Parts

Refer to schematics.

4. Test Set-up and Operation Modes

4.1 Test Methodology

The test methodology used is based on the requirements of 47 CFR Part 15, Sections 15.31, 15.33, 15.35, 15.205, 15.207 and 15.209.

The test methods, which have been used, are based on ANSI C63.10-2009.

For details, see under each test item.

4.2 Operation Modes

Testing was performed at one operation mode with a nominal frequency (24.125GHz) only, since the EUT does not have any standby or receive-only mode.

The basic operation mode used for testing is:

- A. Intended operation continuous transmission and receiving at the channel (24.125GHz), a continuous wave with 100% duty cycle.

4.3 Physical Configuration for Testing

The EUT was tested on a stand-alone basis (only attached to the test jig) and the test system was configured in a typical fashion (as a customer would normally use it).

The justification and manipulation of cables and equipment in order to simulate a worst-case behavior of the test setup has been carried out as prescribed in ANSI C63.10-2009.

Figure 1: Block Diagram

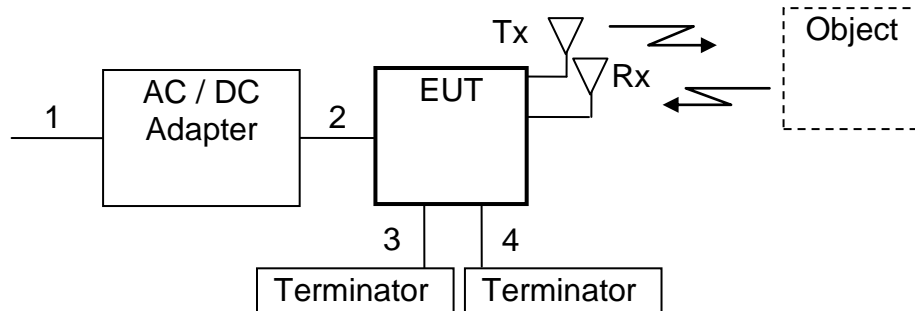

Table 3: Interfaces present on the EUT

No.	Interface	Cable Length for Testing, Shielding	Interface Classification
1.	AC Mains for AC / DC Adapter	1.8m, Un-shielded	AC Input Power Port
2.	DC Mains	1.8m (*), Un-shielded	DC Input Power Port
3.	Doppler signal output (I)	0.2m (*), Shielded	Signal Line
4.	Doppler signal output (Q)	0.2m (*), Shielded	Signal Line

Notes:

(*) Although interface ports 2, 3 and 4 are designed as direct plug-in type by manufacture’s specification, these interface ports were connected with cables as listed above table for testing purpose.

EUT does not need any second radio device for this radio operating, since the EUT is a radar device and does not do any data communication function.

Representative AC / DC adapter provided by the customer was tested together. Interface ports 3 and 4 were terminated with 50ohm terminators during testing.

For more details, refer to section: Photographs of the Test Set-Up.

4.4 Test Software

No special test software was used to operate the EUT.

4.5 Special Accessories and Auxiliary Equipment

The product has been tested together with the following additional accessories:

1. Product: AC / DC Adapter
Manufacturer: UNIFIVE
Model: UI318-05
Rated Voltage: AC 100-240V
Input Current: 0.4A
Output Voltage: DC 5V
Output Current: 3A
Frequency: 50/60Hz
Protection Class: II
Serial Number: E01-0005228

2. Product: 50ohm terminator x2
Manufacturer: Un-specified
Model: Un-specified
Serial Number: Un-specified

4.6 Countermeasures to achieve EMC Compliance

No additional measures were employed to achieve compliance.

5. Test Results RADIO

5.1 Technical Requirements

5.1.1 Supply Voltage Requirements

RESULT: **PASS**

Requirements:

FCC 15.31(e)

For intentional radiators, measurements of the variation of the input power or the radiated signal level of the fundamental frequency component of the emission, as appropriate, shall be performed with the supply voltage varied between 85% and 115% of the nominal rated supply voltage. For battery operated equipment, the equipment tests shall be performed using a new battery.

Verdict:

The EUT has an internal voltage regulator to supply the RF circuit. Hence it complies with the supply voltage requirements.

5.1.2 Antenna Requirements

RESULT: **PASS**

Requirements:

FCC 15.203

An intentional radiator shall be designed to ensure that no antenna other than that furnished by the responsible party shall be used with the device.

Verdict:

The EUT has an internal antenna which is not user accessible. Hence it complies with the antenna requirements.

5.1.3 Restricted Bands of Operation

RESULT:**PASS**

Requirements:

FCC 15.205

Only spurious emissions are permitted in any of the restricted frequency bands, unless otherwise specified.

Verdict:

The EUT operation frequency range is 24.075-24.175GHz. It was verified during testing that the carrier is fully contained within the unrestricted frequency band 24.075-24.175GHz. Therefore only spurious emissions may be found in the restricted bands of operation and the EUT complies with the restricted frequency band requirement.

5.2 Radiated Measurements

5.2.1 Radiated Emissions of Transmitter (Carrier, Spurious and Harmonics)

RESULT:
PASS

Date of testing: 2014-05-14, 2014-05-20, 2014-05-21
2014-05-23

Ambient temperature: 23, 24, 22, 23°C
 Relative humidity: 65, 52, 52, 51%
 Atmospheric pressure: 1000, 1006, 993, 1014hPa

Frequency range: 9kHz - 100GHz
 Measurement distance: 3m in the range 9kHz – 40GHz
 0.5m in the range 40GHz – 100GHz

Kind of test site: Semi Anechoic Chamber

Requirements:

FCC 15.209, 15.245 and 15.205

Radiated emissions must comply with the limits specified in FCC 15.209(a), 15.245(b) (i) and (ii) and 15.205.

Test procedure:

ANSI C63.10-2009

The EUT was placed on a nonconductive turntable 0.8m above the ground plane. Before final measurements of radiated emissions were performed, the EUT was scanned to determine its emission spectrum profile. The physical arrangement of the test system, the associated cabling and the EUT orientation (X, Y, Z) were varied in order to ensure that maximum emission amplitudes were attained.

The spectrum was examined from 9kHz to the 5th harmonic of highest fundamental frequency or to 100 GHz, whichever is lower (i.e. 100GHz) according to the ANSI C63.10-2009 Table 2 of clause 5.5. Final radiated emission measurements were made at 3m or 0.5m distance.

At each frequency where a spurious emission was found, the EUT was rotated 360° and the antenna was raised and lowered from 1 to 4m in order to determine the emission's maximum level. Measurements were taken using both horizontal and vertical antenna polarizations.

For emissions between 30MHz and 1GHz, measurements were performed with a test receiver operating in the CISPR quasi-peak detection mode. The receiver's 6dB bandwidth was set to 120kHz. For emissions above 1GHz, measurements were

Prüfbericht - Nr.: 50006140 001**Seite 14 von 26***Test Report No.:**Page 14 of 26*

performed with a spectrum analyzer using the following settings: for peak field strength: RBW = 1MHz & VBW \geq 1MHz; for average field strength: RBW = 1MHz & VBW = 10Hz.

Absorbers have been placed on the floor between the EUT and the measuring antenna for testing above 1GHz.

The highest emission amplitudes relative to the appropriate limit were recorded in this report. Emissions other than those mentioned are small or not detectable.

No spurious emissions were found in the ranges 9kHz - 30MHz and 40GHz - 100GHz.

The spectra for the range 40GHz-100GHz taken at a distance of 0.5m do not show any spurious emission, 2nd harmonics or 3rd harmonics. Further investigations have however been made with a distance less than 10cm in the range 40GHz-100GHz to confirm that no spurious or harmonic can be detected in this frequency range.

Table 4: Radiated Emissions of the Carrier and Harmonics, Average Data, Modes A (24.125GHz).

Freq. [GHz]	EUT / Antenna Orientation	Reading AV [dB μ V]	Factor [dB(1/m)]	Level AV [dB μ V/m]	Limit [dB μ V/m]	Margin QP [dB]	Height [cm]	Angle [°]
24.12516	Y / V	114.0	-4.9	109.1	128.0	18.9	108	351

Note: No harmonics of the carrier was found at 0.5m distance.

Table 5: Radiated Emissions of the Carrier and Harmonics, Peak Data, Modes A (24.125GHz).

Freq. [GHz]	EUT / Antenna Orientation	Reading PK [dB μ V]	Factor [dB(1/m)]	Level PK [dB μ V/m]	Limit [dB μ V/m]	Margin QP [dB]	Height [cm]	Angle [°]
24.12516	Y / V	114.2	-4.9	109.3	148.0	38.7	108	351

Note: No harmonics of the carrier was found at 0.5m distance.

Table 6: Radiated Spurious Emissions at Band Edge, Modes A (24.125GHz).

Nominal Operating Frequency [GHz]	EUT / Antenna Orientation	Level AV [dBµV/m]	Level PK [dBµV/m]	Limit AV [dBµV/m]	Limit PK [dBµV/m]	Margin AV [dB]	Margin PK [dB]
24.075	Y / V	N/T (*)	49.39	54.00	74.00	N/T (*)	24.61

Notes: All correction factors (antenna, cable, pre-amplifier) are included in the measurement values.
Average limit in dBµV/m is calculated as follows: Average limit = 20 x log(500µV/m).
Peak limit in dBµV/m is calculated as follows: Peak limit = Average limit + 20dB.

(*) Peak emissions level has met against the average limit 54dBµV/m. Therefore, average measurement was omitted.

According to the section 15.205, nearest restricted band of operation is from 23.6 to 24.0GHz. Upper side of this band (i.e. 24.0GHz) is contained in the figure 2.

RBW was used at 3MHz instead of 1MHz. Severe measurement values were obtained.

Figure 2: Radiated Emissions at Band Edge, Spectral Diagram, Mode A (24.125GHz).

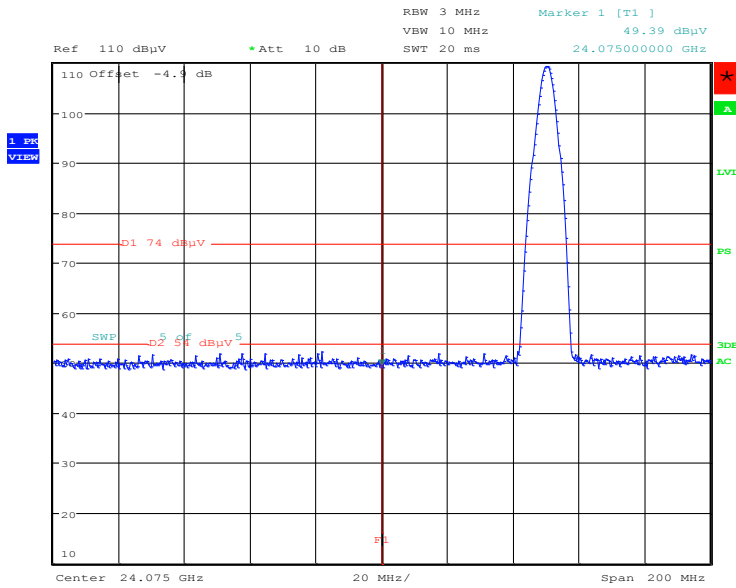

Band Edge, 24.075GHz, Y, Vertical
Date: 21.MAY.2014 11:21:03

Produkte
Products

Prüfbericht - Nr.: 50006140 001

Seite 17 von 26

Test Report No.:

Page 17 of 26

Table 7: Radiated Spurious Emissions, Quasi Peak Data, 30MHz - 1GHz, Horizontal and Vertical Antenna Orientations, Mode A (24.125GHz)

Freq. [MHz]	EUT / Antenna Orientation	Reading QP [dBµV]	Factor [dB(1/m)]	Level QP [dBµV/m]	Limit [dBµV/m]	Margin QP [dB]	Height [cm]	Angle [°]
32.058	Y / V	38.3	-17.3	21.0	40.0	19.0	101	359
41.626	Y / V	38.3	-16.2	22.1	40.0	17.9	101	171
55.834	Y / V	35.5	-16.4	19.1	40.0	20.9	101	21
80.001	Y / V	47.5	-19.3	28.2	40.0	11.8	284	206
119.998	Y / V	39.4	-17.7	21.7	43.5	21.8	100	359

Note: Level QP = Reading QP + Factor

Table 8: Radiated Spurious Emissions, Average Data, 1 - 40GHz, Horizontal and Vertical Antenna Orientations, Mode A (24.125GHz)

Freq. [MHz]	EUT / Antenna Orientation	Reading AV [dBµV]	Factor [dB(1/m)]	Level AV [dBµV/m]	Limit [dBµV/m]	Margin AV [dB]	Height [cm]	Angle [°]
7940.339	Y / H	38.0	1.4	39.4	54.0	14.6	144	301
15415.19	Y / V	38.5	-5.4	33.1	54.0	20.9	151	312
38463.72	Y / V	52.4	-22.1	30.3	54.0	23.7	152	295

Note: Level AV = Reading AV + Factor

Table 9: Radiated Spurious Emissions, Peak Data, 1 - 40GHz, Horizontal and Vertical Antenna Orientations, Mode A (24.125GHz)

Freq. [MHz]	EUT / Antenna Orientation	Reading PK [dBµV]	Factor [dB(1/m)]	Level PK [dBµV/m]	Limit [dBµV/m]	Margin PK [dB]	Height [cm]	Angle [°]
7940.339	Y / H	51.8	1.4	53.2	74.0	20.8	144	301
15415.19	Y / V	52.4	-5.4	47.0	74.0	27.0	151	312
38463.72	Y / V	66.3	-22.1	44.2	74.0	29.8	152	295

Note: Level PK = Reading PK + Factor

Prüfbericht - Nr.: 50006140 001
*Test Report No.:***Seite 18 von 26**
*Page 18 of 26***5.2.2 20dB Band Width****RESULT:****PASS**

Date of testing: 2014-05-21

Ambient temperature: 24°C

Relative humidity: 40%

Atmospheric pressure: 1005hPa

Requirements:

FCC 15.215(c)

Intentional radiators must be designed to ensure that the 20 dB bandwidth of the emission is contained within the frequency band.

Since frequency stability is not specified in the regulations section 15.245, it is recommended that the fundamental emission be kept within at least the central 80% of the permitted band in order to minimize the possibility of out-of-band operation.

Test procedure:

ANSI C63.10-2009

The 20dB bandwidth was measured with a spectrum analyzer using a peak detector. The resolution bandwidth was set to 1kHz and the video bandwidth to 3kHz.

Produkte
Products

Prüfbericht - Nr.: 50006140 001
Test Report No.:

Seite 19 von 26
Page 19 of 26

Table 10: 20dB Bandwidth

Nominal Operating Frequency [GHz]	Actual Center Frequency [GHz]	20dB Bandwidth [kHz]
24.075	24.125	36.858

Note: Since 80% of the permitted band (i.e. 24.075 to 24.175GHz) is from 24.085 to 24.165GHz, Actual center frequency listed as above table is within 80% of the band.

Figure 3: Radiated Emissions at 20dB Bandwidth, Spectral Diagram, Mode A (24.125GHz).

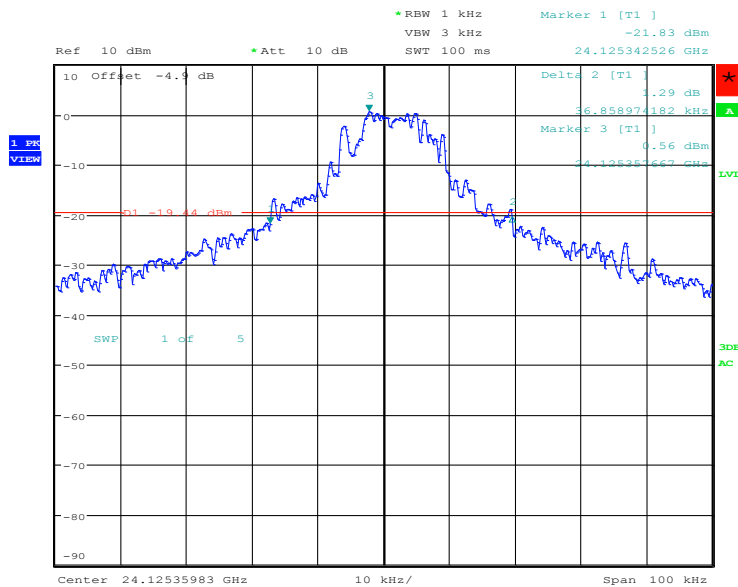

20dB Bandwidth, Y, Vertical
Date: 21.MAY.2014 11:13:57

Note: This 20 dB bandwidth of the emission is contained within the frequency band.

5.3 AC Power Line Conducted Measurements

5.3.1 AC Power Line Conducted Emission of Transmitter

RESULT:**PASS**

Date of testing: 2014-05-21

Ambient temperature: 23°C

Relative humidity: 58%

Atmospheric pressure: 991hPa

Frequency range: 0.15 - 30MHz

Kind of test site: Shielded Room

Requirements:

FCC 15.207

The AC power line conducted emission on any frequency within the band 150kHz to 30MHz shall not exceed the limits specified in FCC 15.207.

Test procedure:

ANSI C63.10-2009

The EUT was placed on a wooden table raised 80cm above the reference ground plane. A vertical conducting plane of the screened room was located 40cm to the rear of the EUT. The AC adapter of the EUT was connected to a Line Impedance Stabilization Network (LISN).

The physical arrangement of the test system and associated cabling was varied to determine the effect on the EUT's emissions in amplitude and frequency in order to ensure that maximum emission amplitudes were attained.

The measurements were performed with a test receiver operating in the CISPR quasi-peak and average detection modes. The receiver's 6dB bandwidth was set to 9kHz.

Disturbances other than those mentioned are small or not detectable.

Produkte
Products

Prüfbericht - Nr.: 50006140 001

Seite 21 von 26

Test Report No.:

Page 21 of 26

Table 11: AC Power Line Conducted Emission, Quasi Peak and Average Data, 0.15 - 30MHz, Phase N (N) and L1 (L), Mode A (24.125GHz)

Freq. [MHz]	Phase	Reading QP [dBµV]	Reading AV [dBµV]	Factor [dB]	Level QP [dBµV]	Level AV [dBµV]	Limit QP [dBµV]	Limit AV [dBµV]	Margin QP [dB]	Margin AV [dB]
0.15203	L1	30.8	12.4	9.6	40.4	22.0	65.9	55.9	25.5	33.9
0.38775	L1	15.9	10.3	9.7	25.6	20.0	58.1	48.1	32.5	28.1
0.68566	L1	6.6	1.7	9.7	16.3	11.4	56.0	46.0	39.7	34.6
1.31261	N	5.6	0.7	9.7	15.3	10.4	56.0	46.0	40.7	35.6
2.05333	L1	5.4	1.0	9.8	15.2	10.8	56.0	46.0	40.8	35.2
4.93898	L1	4.5	-0.8	9.9	14.4	9.1	56.0	46.0	41.6	36.9
9.63726	L1	7.3	3.4	10.0	17.3	13.4	60.0	50.0	42.7	36.6
15.30866	N	0.9	-4.4	10.2	11.1	5.8	60.0	50.0	48.9	44.2

Note: Level QP = Reading QP + Factor, Level AV = Reading AV + Factor

7. List of Tables

Table 1: List of Test and Measurement Equipment	5
Table 2: Emission Measurement Uncertainty	6
Table 3: Interfaces present on the EUT	9
Table 4: Radiated Emissions of the Carrier and Harmonics, Average Data, Modes A (24.125GHz)	15
Table 5: Radiated Emissions of the Carrier and Harmonics, Peak Data, Modes A (24.125GHz)	15
Table 6: Radiated Spurious Emissions at Band Edge, Modes A (24.125GHz)	16
Table 7: Radiated Spurious Emissions, Quasi Peak Data, 30MHz - 1GHz, Horizontal and Vertical Antenna Orientations, Mode A (24.125GHz)	17
Table 8: Radiated Spurious Emissions, Average Data, 1 - 40GHz, Horizontal and Vertical Antenna Orientations, Mode A (24.125GHz)	17
Table 9: Radiated Spurious Emissions, Peak Data, 1 - 40GHz, Horizontal and Vertical Antenna Orientations, Mode A (24.125GHz)	17
Table 10: 20dB Bandwidth	19
Table 11: AC Power Line Conducted Emission, Quasi Peak and Average Data, 0.15 - 30MHz, Phase N (N) and L1 (L), Mode A (24.125GHz)	21

8. List of Figures

Figure 1: Block Diagram	9
Figure 2: Radiated Emissions at Band Edge, Spectral Diagram, Mode A (24.125GHz)	16
Figure 3: Radiated Emissions at 20dB Bandwidth, Spectral Diagram, Mode A (24.125GHz)	19

9. List of Photographs

Photograph 1: Set-up for AC Power Line Conducted Emission of Transmitter, Front View	22
Photograph 2: Set-up for AC Power Line Conducted Emission of Transmitter, Rear View	23
Photograph 3: Set-up for Radiated Emission of Transmitter, Front View	23
Photograph 4: Set-up for Radiated Emission of Transmitter, Rear View	24
Photograph 5: Set-up for Radiated Emission, EUT Configuration X-Axis	24
Photograph 6: Set-up for Radiated Emission, EUT Configuration Y-Axis	25
Photograph 7: Set-up for Radiated Emission, EUT Configuration Z-Axis	25