



## NGT-9000D FCC TEST PROCEDURES AND RESULTS

CAGE Code <b>1WYD3</b>	Initial Release Date <b>26-Jan-2015</b>	Revision Date <b>N/A</b>	Document Number <b>8020133-001</b>	Revision <b>-</b>
---------------------------	--	-----------------------------	---------------------------------------	----------------------

### Proprietary Notice

This document and the information disclosed herein are proprietary data of Aviation Communication & Surveillance Systems, LLC. Neither this document nor the information contained herein shall be reproduced, used, or disclosed to others without the written authorization of Aviation Communication & Surveillance Systems, LLC.

### Notice

Freedom of Information Act (5 USC 552) and Disclosure of Confidential Information Generally (18 USC 1905)

This document is being furnished in confidence by Aviation Communication & Surveillance Systems, LLC. The information disclosed herein falls within exemption (b) (4) of 5 USC 552 and the prohibitions of 18 USC 1905.

### Export Notice

This technical data is controlled under the Export Administration Regulations (EAR) and may not be exported to a Foreign Person, either in the U.S. or abroad, without proper authorization by the U.S. Department of Commerce.

Document Number 8020133-001	NGT-9000D FCC Test Procedures and Results	Revision -
--------------------------------	---	---------------

## Record of Revisions

Rev	Date	Authorization	Description of Change
-	26-JAN-2015	ECR014656	Initial Release

Document Number 8020133-001	NGT-9000D FCC Test Procedures and Results	Revision -
--------------------------------	---	---------------

## Table of Contents

1	INTRODUCTION .....	1
1.1	Purpose .....	1
1.2	Scope.....	1
1.3	References .....	1
1.4	Acronyms and Abbreviations .....	3
2	GENERAL INFORMATION .....	5
2.1	Type Designation.....	5
2.2	Service and Rule for Intended Operation .....	5
2.3	Description of Equipment .....	5
2.3.1	NGT-9000D Functionality.....	5
2.3.1.1	Type of Emission.....	6
2.3.1.2	Frequency Range.....	6
2.3.1.3	Power Rating.....	6
2.3.1.4	Final Power Amplifier .....	6
2.3.1.5	Active Device Functions .....	7
2.3.2	Circuit Diagram.....	7
2.3.3	Instruction Book.....	7
2.3.4	Tune-up Procedure .....	7
2.3.5	Oscillator Circuit .....	7
2.3.6	LO Source Circuitry .....	7
2.3.7	Frequency Stabilization.....	8
2.3.8	Modulation Limiting .....	8
2.3.9	Radiated Interference Suppression.....	8
3	MODULATION DETAILS .....	10
3.1	ATCRBS Interrogations .....	10
3.2	ATCRBS Replies .....	11
3.3	Mode S Replies .....	13
4	DRAWINGS AND PHOTOGRAPHS .....	14
4.1	Drawings.....	14
4.2	Photographs .....	14
4.3	FCC Compliance Test Plan .....	14
4.4	FCC Compliance Overview .....	14
4.4.1	FCC Identifier .....	14
4.4.2	Changes in Certified Equipment .....	14
4.5	NGT-9000D Model to be Subjected to FCC Compliance Testing.....	15
4.5.1	Conclusion.....	15
5	EQUIPMENT AND SETUP .....	16
5.1	Test Facilities.....	16
5.2	Test Equipment.....	16
5.2.1	Setup Block Diagram .....	16
5.3	LRU Setup .....	16
5.3.1	Hardware Configuration .....	17
5.3.2	Software Configuration.....	17
5.4	Photographs .....	18
6	TEST SCHEDULE .....	28
7	FCC COMPLIANCE TEST PROCEDURES.....	29
7.1	RF Power Output.....	29
7.1.1	RF Power Output Test Equipment Required .....	29
7.1.2	RF Power Output Test Setup .....	30
7.1.3	RF Power Output Test Procedure.....	30
7.1.4	Test Result Data.....	30
7.2	Modulation Characteristics .....	31
7.2.1	Modulation Characteristics Test Equipment Required.....	31
7.2.2	Modulation Characteristics Test Setup .....	31

Document Number 8020133-001	NGT-9000D FCC Test Procedures and Results	Revision -
--------------------------------	---	---------------

7.2.3	Modulation Characteristics Test Procedure .....	31
7.2.4	Modulation Characteristics Test Results.....	32
7.3	Occupied Bandwidth.....	33
7.3.1	Occupied Bandwidth Test Equipment Required .....	33
7.3.2	Occupied Bandwidth Test Setup.....	34
7.3.3	Occupied Bandwidth Test Procedure .....	34
7.3.4	Occupied Bandwidth Test Results .....	34
7.4	Spurious Emissions at Antenna Terminals.....	34
7.4.1	Spurious Emissions at Antenna Terminals Test Equipment Required .....	35
7.4.2	Spurious Emissions at Antenna Terminals Test Setup.....	35
7.4.3	Spurious Emissions at Antenna Terminals Test Procedure.....	35
7.4.4	Spurious Emissions at Antenna Terminals Test Results .....	35
7.5	Spurious Emissions at Antenna Terminals Local Oscillator Leakage (916 MHz) .....	36
7.5.1	Spurious Emissions at Antenna Terminals Local Oscillator Leakage (916 MHz) Test Equipment Required .....	36
7.5.2	Spurious Emissions at Antenna Terminals Local Oscillator Leakage Test Setup .....	36
7.5.3	Spurious Emissions at Antenna Terminals Local Oscillator Leakage Test Procedure .....	36
7.5.4	Spurious Emissions at Antenna Terminals Test Results .....	36
7.6	Field Strength of Spurious Radiation.....	37
7.6.1	Field Strength of Spurious Radiation Test Equipment Required .....	38
7.6.2	Field Strength of Spurious Radiation Test Setup.....	38
7.6.3	Field Strength of Spurious Radiation Test Procedure.....	38
7.6.4	Field Strength of Spurious Radiation Test Results .....	39
7.7	Frequency Stability .....	39
7.7.1	Frequency Stability (Temperature Variation) .....	39
7.7.1.1	Frequency Stability (Temperature Variation) Test Equipment Required .....	39
7.7.1.2	Frequency Stability (Temperature Variation) Test Setup.....	39
7.7.1.3	TAS and Transponder Frequency Stability (Temp Variation) Test Procedure .....	40
7.7.1.4	TAS and Transponder Frequency Stability (Temperature Variation) Test Results .....	40
7.7.2	Frequency Stability (Primary Power Variation) .....	41
7.7.2.1	Frequency Stability (Primary Power Variation) Test Equipment Required .....	41
7.7.2.2	Frequency Stability (Primary Power Variation) Test Setup.....	42
7.7.2.3	TAS and Transponder Frequency Stability (Primary Power Variation) Test Procedure .....	42
7.7.2.4	Frequency Stability (Primary Power Variation) Test Results .....	42
APPENDIX A	DNB TEST DATA – RIVERSIDE, CA .....	44
END OF DOCUMENT	.....	118

Document Number 8020133-001	NGT-9000D FCC Test Procedures and Results	Revision -
--------------------------------	---	---------------

## Table of Figures

Figure 3-1: ATCRBS Whisper Shout Interrogations .....	10
Figure 3-2 ATCRBS Mode C Interrogation .....	11
Figure 3-3: ATCRBS Reply .....	12
Figure 3-4: Mode S Reply .....	13
Figure 5-1: Test Equipment Setup .....	16
Figure 5-2: NGT-9000D inside the Temperature Chamber .....	17
Figure 5-3: NGT-9000D Front View .....	18
Figure 5-4: NGT-9000D Rear View.....	19
Figure 5-5: NGT-9000D Top View with Top Cover Removed .....	20
Figure 5-6: NGT-9000D Side View With Top Cover Removed.....	21
Figure 5-7: NGT-9000D with GPS-UAT CCA Removed.....	22
Figure 5-8: GPS-UAT CCA Top Side.....	23
Figure 5-9: GPS-UAT CCA Bottom Side .....	24
Figure 5-10: NGT-9000D with GPS-UAT CCA and Main CCA Removed .....	25
Figure 5-11: NGT-9000D Main CCA Top Side .....	26
Figure 5-12: NGT-9000D Main CCA Bottom Side .....	27
Figure 7-1: RF Power Output Test Setup .....	30
Figure 7-2: Modulation Characteristics Test Setup.....	31
Figure 7-3: Occupied Bandwidth Test Setup .....	34
Figure 7-4: Spurious Emissions at Antenna Terminals Test Setup .....	35
Figure 7-5: Spurious Emissions at Antenna Terminals Local Oscillator Leakage Test Setup .....	36
Figure 7-6: Field Strength of Spurious Radiation Test Setup .....	38
Figure 7-7: Frequency Stability (Temperature Variation) Test Setup for UAT Transmission .....	39
Figure 7-8: Frequency Stability (Primary Power Variation) Test Setup .....	42

Document Number 8020133-001	NGT-9000D FCC Test Procedures and Results	Revision -
--------------------------------	---	---------------

## Table of Tables

Table 1-1: Referenced ACSS Documents .....	1
Table 1-2: Referenced Industry Documents .....	1
Table 1-3: Referenced FCC Documents.....	3
Table 1-4: Acronyms and Abbreviations .....	3
Table 2-1: NGT-9000D Active Devices .....	7
Table 2-23 1090 MHz Transmitter Spectral Mask .....	9
Table 3-1: Whisper Shout Power Levels.....	10
Table 5-1: NGT9000D+ Software .....	18
Table 7-1: RF Power Output Test Equipment Required .....	29
Table 7-2: NGT-9000D Peak power output .....	30
Table 7-3: Modulation Characteristics Test Equipment Required .....	31
Table 7-4: Signal Analyzer settings for modulation characteristics measurement .....	32
Table 7-5: NGT-9000D TAS Modulation related parameter measurement .....	32
Table 7-6: NGT-9000D XPDR Modulation related parameter measurement .....	33
Table 7-7: Occupied Bandwidth Test Equipment Required.....	33
Table 7-8 Occupied Bandwidth .....	34
Table 7-9: Spurious Emissions at Antenna Terminals Test Equipment Required.....	35
Table 7-10: Spurious Emissions at Antenna Terminals Local Oscillator Leakage (916 MHz) Test Equipment Required .....	36
Table 7-11: Spurious Emissions at Top Antenna Terminal .....	37
Table 7-12: Spurious Emissions at Bottom Antenna Terminal .....	37
Table 7-13: Allowable radiated emissions levels for units containing digital devices per 47CFR15.109 ...	37
Table 7-14: Field Strength of Spurious Radiation Test Equipment Required.....	38
Table 7-15: Frequency Stability (Temperature Variation) Test Equipment Required.....	39
Table 7-16: Frequency Stability (Temperature Variation) Test Results TAS.....	40
Table 7-17: Frequency Stability (Temperature Variation) Test Results XPDR.....	41
Table 7-18: Frequency Stability (Primary Power Variation) Test Equipment Required.....	41
Table 7-19: Frequency Stability (Primary Power variation) Test Results .....	42

Document Number 8020133-001	NGT-9000D FCC Test Procedures and Results	Revision -
--------------------------------	---	---------------

## 1 INTRODUCTION

The NGT-9000D is a Diversity Mode-S Transponder that provides Automatic Dependent Surveillance-Broadcast (ADS-B) support using the Mode-S Extended Squitter. The NGT-9000D also includes a built-in Traffic Advisory System (TAS) transceiver, Universal Access Transceiver (UAT) 978 MHz receiver and built-in GPS receiver.

The NGT-9000D is designed to operate with a power supply ranging from +14V to +28V VDC.

### 1.1 Purpose

The purpose is to provide the FCC compliance plan and test results for the NGT-9000D equipment.

### 1.2 Scope

This test results document establishes the FCC compliance plan and procedures for NGT-9000D, Part Number 9029000-20000.

### 1.3 References

**Table 1-1: Referenced ACSS Documents**

Document No.	Revision	Description
8020043-001	B	NGT-9000 System Test Procedures for –xx000
8020130-001	B	NGT-9000 Environmental Qualification Test Plan
9029000-20000	A	NGT-9000 Hardware Assembly Drawing
9200-17000-01	N,U	Assembly, NGT-9000 Diversity Hardware End item
9200-17001-01	C	Assembly, NGT-9000 Non-Diversity Hardware End item
9020020-001	G,J	NGT-9000 CCA Drawing
0160-17000-01	F	Panel Mount Installation Procedures

**Table 1-2: Referenced Industry Documents**

Source	Document No.	Revision	Description
FAA	AC 20-151B	3/18/2014	Airworthiness Approval of Traffic Alert and Collision Avoidance Systems (TCAS II), Versions 7.0 & 7.1 and Associated Mode S Transponders
FAA	TSO-C112d	6/6/2011	Air Traffic Control Radar Beacon System/Mode Select (ATCRBS/Mode S) Airborne Equipment
RTCA	DO-181E	3/17/2011	Minimum Operational Performance Standards for Air Traffic Control Radar Beacon System/Mode Select (ATCRBS/Mode S) Airborne Equipment

ACSS Proprietary	Use or disclosure of the information on this sheet is subject to the proprietary notice on the title page.	Page-118
---------------------	--	----------

Document Number 8020133-001	NGT-9000D FCC Test Procedures and Results	Revision -
--------------------------------	---	---------------

Source	Document No.	Revision	Description
FAA	AC 20-165A	11/7/2012	Airworthiness Approval of Automatic Dependent Surveillance – Broadcast (ADS-B) Out Systems
FAA	TSO-C166b	12/2/2009	Extended Squitter Automatic Dependent Surveillance - Broadcast (ADS-B) and Traffic Information Service – Broadcast (TIS-B) Equipment Operating on the Radio Frequency of 1090 Megahertz (MHz)
RTCA	DO-260B with Corrigendum 1	12/13/2011	Minimum Operational Performance Standards for 1090 MHz Extended Squitter Automatic Dependent Surveillance – Broadcast (ADS-B) and Traffic Information Services – Broadcast (TIS-B)
FAA	TSO-C147	4/6/1998	Traffic Advisory System (TAS) Airborne Equipment
RTCA	DO-197A, Change 1	7/29/1997	Minimum Operational Performance Standards for an Active Traffic Alert and Collision Avoidance System I (Active TCAS I), Change 1
FAA	AC-20-172A	3/23/2012	Airworthiness Approval for ADS-B In Systems and Applications
FAA	TSO-C154c	12/2/2009	Universal Access Transceiver (UAT) Automatic Dependent Surveillance-Broadcast (ADS-B) Equipment Operating on Frequency of 978 MHz
RTCA	DO-282B with Corrigendum 1	12/13/2011	Minimum Operational Performance Standards (MOPS) for Universal Access Transceiver (UAT) Automatic Dependent Surveillance-Broadcast (ADS-B)
FAA	TSO-C157a	9/9/2011	Aircraft Flight Information Services – Broadcast (FIS-B) Data Link Systems and Equipment
RTCA	DO-267A	4/29/2004	Minimum Aviation System Performance Standards (MASPS) for Flight Information Services-Broadcast (FIS-B) Data Link
FAA	TSO-C195a	2/29/2012	Avionics Supporting Automatic Dependent Surveillance – Broadcast (ADS-B) Aircraft Surveillance Applications (ASA)
RTCA	DO-317A	12/13/2011	Minimum Operational Performance Standards (MOPS) for Aircraft Surveillance Applications (ASA) System
FAA	AC20-138D	3/28/2014	Airworthiness Approval of Positioning and Navigation Systems
FAA	TSO-C145c	5/2/2008	Airborne Navigation Sensors Using The Global Positioning System Augmented By The Satellite Based Augmentation System
RTCA	DO-229D, Change 1	2/1/2013	Minimum Operational Performance Standards for Global Positioning System/Satellite-Based Augmentation System Airborne Equipment
RTCA	DO-160G	12/8/2010	Environmental Conditions and Test Procedures For Airborne Equipment



Document Number 8020133-001	NGT-9000D FCC Test Procedures and Results	Revision -
--------------------------------	---	---------------

**Table 1-3: Referenced FCC Documents**

Document No.	Description
CFR Title 47 Chapter 1 Part 2 Subpart J	Code of Federal Regulations – Telecommunications Federal Communications Commission Frequency Allocations and Radio Treaty Matters; General Rules and Regulations Equipment Authorization Procedures Revised as of October 1, 2001
CFR Title 47 Chapter 1 Part 15 Subpart A	Code of Federal Regulations – Telecommunications Federal Communications Commission Radio Frequency Devices General Revised as of October 1, 2001
CFR Title 47 Chapter 1 Part 87	Code of Federal Regulations, Telecommunication. Part 87 – Aviation Services Revised as of 10/01/1989
PART 87	Code of Federal Regulations, Telecommunication. Part 87 – Aviation Services

## 1.4 Acronyms and Abbreviations

**Table 1-4: Acronyms and Abbreviations**

Acronym	Definition
ACSS	Aviation Communication and Surveillance Systems
ADSB	Automatic Dependent Surveillance – Broadcast
ASA	Aircraft Surveillance Applications
ASK	Amplitude Shift Keying
ATCRBS	Air Traffic Control Radar Beacon System
ATE	Automated Test Equipment
CCA	Circuit Card Assembly
CFR	Code of Federal Regulations
CPFSK	Continuous Phase Frequency Shift Keying
CRC	Cyclic Redundancy Check
dB	Decibel
EVAcq	Enhanced Visual Acquisition
FAA	Federal Aviation Administration
FCC	Federal Communications Commission
FET	Field Effect Transistor
FIS-B	Flight Information Service - Broadcast
FPGA	Field Programmable Gate Array
FSK	Frequency Shift Keying
GHz	Giga Hertz
GPS	Global Positioning System
IF	Intermediate Frequency
kHz	kilo Hertz
LDMOS	Laterally Diffused Metal Oxide Semiconductor
LNA	Low Noise amplifier
LO	Local Oscillator
LRU	Line Replaceable Unit

ACSS Proprietary	Use or disclosure of the information on this sheet is subject to the proprietary notice on the title page.	Page-3
---------------------	---	--------

Document Number 8020133-001	NGT-9000D FCC Test Procedures and Results	Revision -
--------------------------------	---	---------------

Acronym	Definition
MASPS	Minimum Aviation System Performance Standards
Mbps	Mega bits per second
MHz	Mega Hertz
MOPS	Minimum Operational Performance Standards
ns	Nanosecond
PC	Personal Computer
PLL	Phase Locked Loop
PPM	Parts Per Million
PSK	Phase Shift Keying
RF	Radio Frequency
rms	root mean square
RTCA	Radio Technical Commission for Aeronautics
TCXO	Temperature Compensated Crystal Oscillator
TSO	Technical Standard Order
UAT	Universal Access Transceiver
us	Microsecond
UUT	Unit Under Test
VCO	Voltage Controlled Oscillator
VDC	Volts Direct Current

Document Number 8020133-001	NGT-9000D FCC Test Procedures and Results	Revision -
--------------------------------	---	---------------

## 2 GENERAL INFORMATION

### 2.1 Type Designation

The equipment has been designated by ACSS as NGT-9000D, P/N 9029000-20XXX.

### 2.2 Service and Rule for Intended Operation

Air Traffic Control  
Part 87, Subpart A

### 2.3 Description of Equipment

#### 2.3.1 NGT-9000D Functionality

The NGT-9000D is a Mode S Transponder that provides 1090 MHz Automatic Dependent Surveillance-Broadcast (ADS-B) information with the following functionality:

- 1090 Mode-S Level 2dens transponder functions including the 1090ES ADS-B Input and Output functions.
  - 1090 Mode S Transponder function is available as a single or optional diversity antenna configuration.
- An internally integrated GPS/UAT receive-only module supporting Class Beta 1 GPS functions that provides the required GPS data for ADS-B input and output functions.
  - Note: the NGT-9000D only utilizes the internal GPS as its position source; no external GPS inputs are supported.
- ADS-B traffic (UAT & 1090) and FIS-B weather and FIS-B textual data products will be output from the transponder via serial (RS-422 or RS-232) interfaces to external cockpit displays.
- An ARINC 735B compatible output of traffic (ADS-B, ADS-R, and TIS-B) is supported for conventional traffic (TAS) and CDTI displays.
- Panel mount versions of the transponder will also display the traffic (ADS-B, ADS-R, and TIS-B) and FIS-B products on the touch screen panel.
- The NGT-9000D system also supports a Traffic Advisory System (TAS) function.

ACSS is seeking approval for the following FAA TSOs:

- a. TSO-C112d Air Traffic Control Radar Beacon System/Mode Select (ATCRBS / Mode S) Airborne Equipment:
  - Level 2dens Class 1
- b. TSO-C113a Airborne Multipurpose Electronic Displays
- c. TSO-C145c Airborne Navigation Sensors Using The Global Positioning System Augmented By The Satellite Based Augmentation System
  - Class Beta 1
- d. TSO-C147 Traffic Advisory System (TAS) Airborne Equipment
  - Class A
- e. TSO-C154a Universal Access Transceiver (UAT) Automatic Dependent Surveillance-Broadcast (ADS-B) Equipment Operating on Frequency of 978 MHz
  - Class A1S Receive Only
- f. TSO-C157a Aircraft Flight Information Services-Broadcast (FIS-B) Data Link Systems and Equipment
  - Class 2

Document Number 8020133-001	NGT-9000D FCC Test Procedures and Results	Revision -
--------------------------------	---	---------------

- g. TSO-C166b Extended Squitter Automatic Dependent Surveillance - Broadcast (ADS-B) and Traffic Information Service - Broadcast (TIS-B) Equipment Operating on the Radio Frequency of 1090 Megahertz (MHz)
  - Class A2
- h. TSO-C195a Avionics Supporting Automatic Dependent Surveillance – Broadcast (ADS-B) Aircraft Surveillance Applications (ASA)
  - Class B1, B5, C1, & C5

### 2.3.1.1 Type of Emission

Mode S and ATRBS Transmissions: 18MOP1D

### 2.3.1.2 Frequency Range

Mode S Transmission: 1090 MHz  $\pm$  1 MHz  
 ATRBS Transmission 1030 MHz  $\pm$  0.2 MHz

### 2.3.1.3 Power Rating

500 Watts Peak Effective Isotropic Radiated Power (Pulsed, 1090 MHz)  
*Note: This assumes 3 dBi antenna gain, per TSO-C112d*

1.74 Watts to 500 Watts Peak Effective Radiated Power (Pulsed, 1030 MHz)  
*Note: This assumes 3 dBi antenna gain, per TSO-147c*

### 2.3.1.4 Final Power Amplifier

The final power amplifier is a 350W LDMOS FET with approximately 15 dB of gain. The transmitter chain and final power amplifier is common for both 1030 MHz and 1090 MHz transmissions.

Document Number 8020133-001	NGT-9000D FCC Test Procedures and Results	Revision -
--------------------------------	---	---------------

### 2.3.1.5 Active Device Functions

Table 2-1: NGT-9000D Active Devices

Function	Device Type	Part	Manufacturer
Oscillator	Reference Crystal Oscillator (XO)	CB3LV-31-64M0000	CTS Corp
	PLL Device with integrated VCO	ADF4360 chip	Analog Devices
	Broadband RFIC Amplifier	ABA-53563	AVAGO Technologies
Transmitter	Gain Block, Id = 35mA, 17 dB Gain	ADA-4643	AVAGO Technologies
	Broad Band RFIC Amp, Id = 46mA, 21.5 dB Gain	ABA-53563	AVAGO Technologies
	High Linearity Y-Mixer	ADL5350	Analog Devices
	Broad Band RFIC Amp, Id = 46mA, 21.5 dB Gain	ABA-53563	AVAGO Technologies
	0.1W High Gain Driver Amplifier	MGA-31389	AVAGO Technologies
	4W LDMOS Amplifier	MW6S004NT1	Freescale Semiconductor
	18W LDMOS Amplifier	PD57018-E	ST Microelectronics
Pulse Modulator	350W LDMOS Amplifier	STAC1011-350A	ST Microelectronics
	12-bit DAC	AD9706B	Analog Devices

### 2.3.2 Circuit Diagram

A block diagram and schematics will be provided with the FCC Form 731 when the application for certification is filed with the FCC.

### 2.3.3 Instruction Book

An ACSS document, Installation Manual (0040-17001-01) provides instructions for the proper installation of the NGT-9000D on a given aircraft.

### 2.3.4 Tune-up Procedure

No field tuning is required. Alignment is performed in the factory.

### 2.3.5 Oscillator Circuit

One (1) LO circuit exists in the NGT-9000 LRU. The LO generates the 916 MHz signal used by the Transceiver CCA's down converting mixers in the receivers and up converting mixer in the transmitter chains. The LO utilizes a 64 MHz crystal oscillator. The FPGA programming determines the PLL multiplier and divider ratios which determine the LO frequency (916 MHz).

### 2.3.6 LO Source Circuitry

The LO signal is generated in U81, which is an integrated VCO and phase-locked loop (PLL) circuit. The LO signal output is passed through a series-resonant LC circuit and then passed to an RF amplifier. The output of the LO circuit is passed to the LO distribution circuitry, splitting the output and providing the LO signal to the transmitter mixer, the top receiver mixer, and the bottom receiver mixer.

ACSS Proprietary	Use or disclosure of the information on this sheet is subject to the proprietary notice on the title page.	Page-7
---------------------	--	--------

Document Number 8020133-001	NGT-9000D FCC Test Procedures and Results	Revision -
--------------------------------	---	---------------

The inductors are used to set the oscillation range when the LO is implemented using the ADF4360-6 component. The R-C network between pins 7 and 24 on each chip is part of the oscillator feedback circuit that affects stability, phase noise, and lock time. The signal pin 20 indicates when the PLL is in “locked” mode, which occurs after the inputs to the phase detector within the ADF4360 are in phase, and indicates that the oscillator is on frequency.

The control voltage input on pin 23 is the active high “Chip Enable” signal, and is permanently pulled to  $V_{CC}$ .

Programming of the LO oscillator is done using the LE, CLK, and DATA inputs (Driven by the Artix 7 FPGA) to the ADF4360 chip.

### 2.3.7 Frequency Stabilization

Crystal Oscillator (XO)

### 2.3.8 Modulation Limiting

Not Applicable

### 2.3.9 Radiated Interference Suppression

The modulation bandwidth of the pulsed signal is controlled by affecting the rise and fall times of the RF pulses generated by the transmitter. Prior to the gain stages and final amplifier, there is a band pass filter intended to filter out spurious signals and attenuate sideband emissions caused by modulation. After the final amplifier, a harmonic filter is used to attenuate the 2<sup>nd</sup> and 3<sup>rd</sup> harmonics of the transmitted signal.

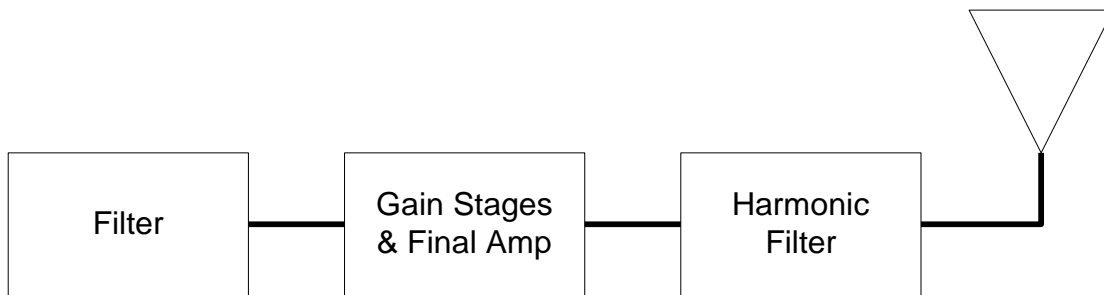

The spectral output for 1030 MHz transmissions will be limited to the following schedule:

**Table 2-2 1030 MHz Transmitter Spectral Mask**

Frequency difference (MHz from carrier)	Maximum Relative power (dBc below maximum)
$\geq 0.7, < 5$	3dBc
$\geq 5, < 20$	20dBc
$\geq 20, < 60$	40dBc
$\geq 60$	60dBc

The spectral output for 1090 MHz transmissions will be limited to the following schedule:

Document Number 8020133-001	NGT-9000D FCC Test Procedures and Results	Revision -
--------------------------------	---	---------------

**Table 2-23 1090 MHz Transmitter Spectral Mask**

<b>Frequency difference (MHz from carrier)</b>	<b>Maximum Relative power (dBc below maximum)</b>
$\geq 1.3, < 7$	3dBc
$\geq 7, < 23$	20dBc
$\geq 23, < 78$	40dBc
$\geq 78$	60dBc

### 3 MODULATION DETAILS

#### 3.1 ATCRBS Interrogations

ATCRBS interrogations are transmitted at 1030 MHz using a 7 step whisper/shout transmission scheme. Interrogations are sent out on an intentionally jittered 1+0.2 second interval in increasing power levels according to the schedules shown in Table 3-1. By transmitting the weakest signals first, only the closest aircraft will reply. The interrogations progress in a roughly circular pattern weighted toward the front of the aircraft since that is the area from which the greatest closing speeds originate. In areas of high density the sequence is halted when the computer has reached a limit defined by a complex set of three inequalities. In this manner, interference to other TCAS equipped aircraft in the area is minimized since the strongest interrogations are the first to be dropped.

**Table 3-1: Whisper Shout Power Levels**

(in Watts)	Sequence #1		Sequence #2		Sequence #3		Sequence #4		Sequence #5	
	S1	P1/P3	S1	P1/P3	S1	P1/P3	S1	P1/P3	S1	P1/P3
WSL 7									21.88	158.5
WSL 6							21.88	70.79		
WSL 5					9.77	31.62	9.77	31.62	9.77	31.62
WSL 4			4.37	14.13	4.37	14.13	4.37	14.13	4.37	14.13
WSL 3	1.95	6.31	1.95	6.31	1.95	6.31	1.95	6.31	1.95	6.31
WSL 2	0.87	2.82	0.87	2.82	0.87	2.82	0.87	2.82	0.87	2.82
WSL 1		1.26		1.26		1.26		1.26		1.26
$P_{total}$ (W)		10.39		24.51		56.14		126.9		214.6

  

(in dBm)	Sequence #1		Sequence #2		Sequence #3		Sequence #4		Sequence #5	
	S1	P1/P3	S1	P1/P3	S1	P1/P3	S1	P1/P3	S1	P1/P3
WSL 7									43.4	52
WSL 6							43.4	48.5		
WSL 5					39.9	45	39.9	45	39.9	45
WSL 4			36.4	41.5	36.4	41.5	36.4	41.5	36.4	41.5
WSL 3	32.9	38	32.9	38	32.9	38	32.9	38	32.9	38
WSL 2	29.4	34.5	29.4	34.5	29.4	34.5	29.4	34.5	29.4	34.5
WSL 1		31		31		31		31		31
$P_{total}$ (dBm)		40.2		43.9		47.5		51		53.3



**Figure 3-1: ATCRBS Whisper Shout Interrogations**



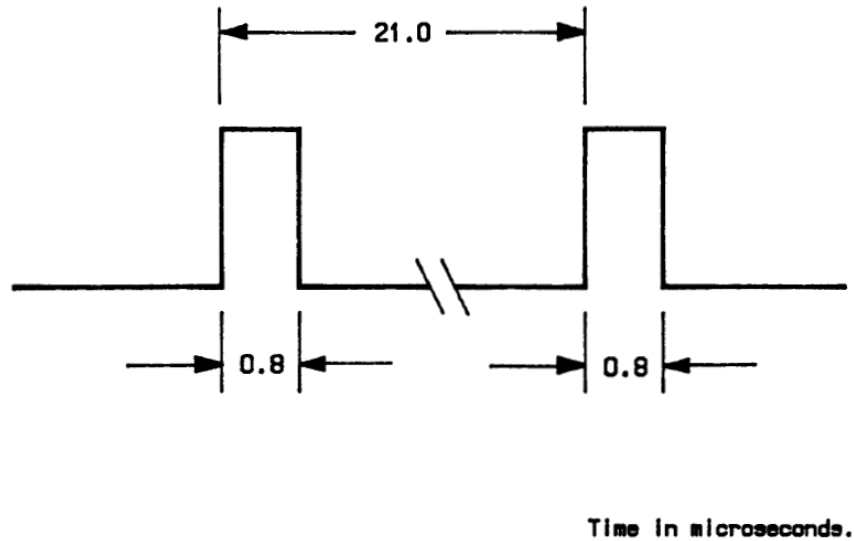

**Figure 3-2 ATCRBS Mode C Interrogation**

Pulse Widths:	$0.8 \pm 0.05$ usec
Rise Times (10% to 90%):	$\geq 0.05$ usec., $< 0.1$ usec
Fall Times (90% to 10%):	$\geq 0.05$ usec., $< 0.2$ usec

Pulses P1 and P3 will appear in all interrogation steps of the whisper / shout sequence and will be at the same power level. Pulse S1 will appear in all steps except the initial step on each antenna direction and at a level two or three dB below the level of P1, etc. according to the schedules shown in Figure 3-1 through Figure 3-4. The steps occur at intervals of two milliseconds until the entire program is complete. The program length depends upon the individual aircraft installation.

S1 =	-2 microseconds
P1 =	0 microseconds
P3 =	21 microseconds

### 3.2 ATCRBS Replies

ATCRBS replies are 1090 MHz pulse amplitude modulated signals (PAM), and are formed in response to Mode A or Mode C interrogations. Mode A replies consist of a 4096 code which is an identifier and an optional SPI pulse. Mode C replies consist of a code used to communicate the aircrafts altitude. The same pulse spacing and bit definition applies to both Mode A and Mode C replies. The Transmitter transmits ATCRBS reply pulse waveforms as shown in Figure 3-3.

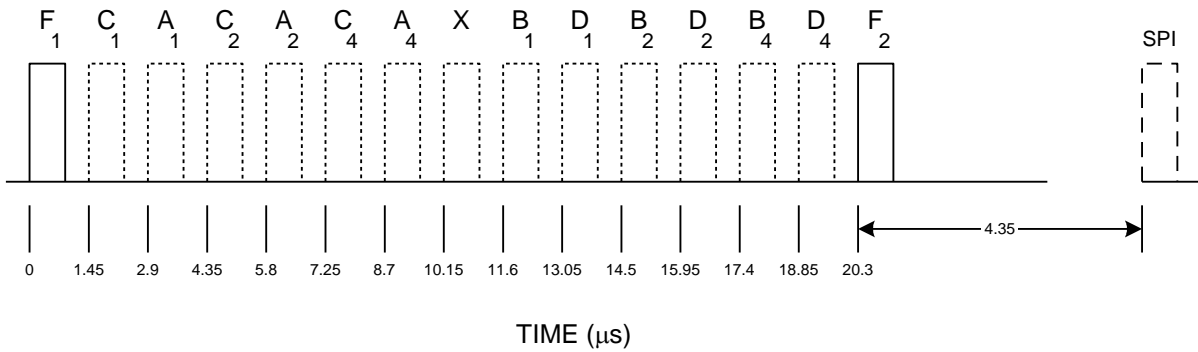

**Figure 3-3: ATCRBS Reply**

The designator of the information pulses and their positions from the first framing pulse are as follows:

**Table 3-3: ATCRBS Reply Pulse Characteristics/Position**

Pulse	Position (μsec)
FIRST FRAMING PULSE	0.0
C1	1.45
A1	2.90
C2	4.35
A2	5.80
C4	7.25
A4	8.70
X <sup>1</sup>	10.15
B1	11.60
D1	13.05
B2	14.50
D2	15.95
B4	17.40
D4	18.85
LAST FRAMING PULSE	20.30
SPI	24.65

*Note 1: The X pulse is referenced here for possible future use.*

The ATCRBS Reply Pulse Spacing Tolerance is as follows:

- First framing pulse to information/last framing pulse ± 0.1 μsec
- Last framing pulse to SPI pulse ± 0.1 μsec
- Any 2 pulses in pulse group (except First framing pulse) ± 0.15 μsec

The ATCRBS pulse characteristics are as specified in the table below.

**Table 3-4: ATCRBS Reply Pulses (in microseconds)**

Pulse Designator	Pulse Duration	Duration Tolerance	Rise Time		Decay Time	
			Min.	Max.	Min.	Max.
ATCRBS Reply Pulses	0.45	± 0.10	0.05	0.1	0.05	0.2

### 3.3 Mode S Replies

Mode S (Short & Long) replies, including preamble, data pulse, pulse shape, pulse spacing tolerance, and delay and jitter characteristics will be as follows.

The Transmitter CCA transmits Mode S reply pulse waveforms as shown in Figure 3-4.

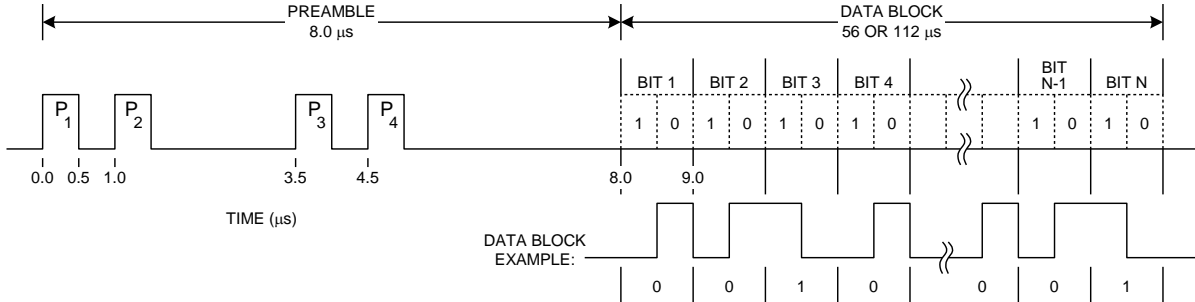

**Figure 3-4: Mode S Reply**

1. Mode S Reply
  - a. The Mode S preamble consists of four  $0.5 \pm 0.05$  microsecond pulses.
  - b. The second, third and fourth pulses are spaced 1.0, 3.5, and 4.5 microseconds respectively from the first transmitted pulse.
  - c. The block of reply data pulses begins 8.0 microseconds after the first transmitted pulse and is either 56 or 112 one microsecond intervals depending on the type of Mode S Reply.
  - d. A pulse with a width of  $0.5 \pm 0.05$  microseconds is transmitted either in the first (data bit “1”) or in the second half (data bit “0”) of each interval. Also, if a pulse transmitted in the second half of one interval is followed by a pulse transmitted in the first half of the next interval, the two pulses merge. Once the merging occurs, a  $1.0 \pm 0.05$  microsecond pulse is transmitted
2. Mode S Reply Pulse Shape
  - a. The pulse rise and decay time are as specified in the table below.

**Table 3-5: Mode S Reply Pulses (in microseconds)**

Pulse Designator	Rise Time		Decay Time	
	Min.	Max.	Min.	Max.
<b>Mode S Reply Pulses</b>	0.05	0.1	0.05	0.2

3. Mode S Reply Pulse Spacing Tolerance
  - a. Mode S Reply pulses start at a defined multiple of 0.5 microseconds from the first transmitted pulse.
  - b. The pulse position tolerance shall be  $\pm 0.05$  microseconds, measured from the first pulse of the reply.

Document Number 8020133-001	NGT-9000D FCC Test Procedures and Results	Revision -
--------------------------------	---	---------------

## 4 DRAWINGS AND PHOTOGRAPHS

### 4.1 Drawings

Refer to Table 1-1 for a list of ACSS drawings that will be furnished with the application.

### 4.2 Photographs

Photographs of the NGT-9000D units will be included in the FCC Compliance Test Report.

### 4.3 FCC Compliance Test Plan

### 4.4 FCC Compliance Overview

The Code of Federal Regulations, Title 47, Volume 1, Part 2, Subpart J (47CFR2.xxxx) provides procedures for radio frequency equipment to be authorized by the FCC. Certification is an equipment authorization issued by the commission, based on representations and test data submitted by the applicant. Certification attaches to all units subsequently marketed by the grantee which are identical (see section 4.4.2) to the sample tested except for permissive changes or other variations authorized by the commission.

#### 4.4.1 FCC Identifier

47CFR2.924 states that equipment, which has been authorized by the FCC, bears an FCC Identifier. Equipment, which has been authorized, may be marketed under different model/type numbers or trade names without additional authorization from the commission, provided that such devices are electrically identical and the equipment bears an FCC Identifier validated by a grant of equipment authorization.

#### 4.4.2 Changes in Certified Equipment

47CFR2.907, 8 defines Identical as either being units whose variances fall within those expected to arise as a result of quantity production techniques, or those which have been changed where the change meets the criteria of a *permissive change*.

47CFR2.1043 states that changes to the basic frequency determining and stabilizing circuitry (including clock or data rates), frequency multiplication stages, basic modulator circuit or maximum power or field strength ratings shall not be performed without application for and authorization of a new grant of certification.

*Variations in electrical or mechanical construction, other than the above indicated items, are permitted provided the variations either do not affect the characteristics required to be reported to the commission or are made in compliance with other provisions in 47CFR2.1043*

Two classes of permissive changes may be made in certified equipment without requiring a new application for and grant of certification. Neither class of change shall result in a change of identification.

- A Class I permissive change includes those modifications in the equipment that do not degrade the characteristics reported by the manufacturer and accepted by the commission when certification is granted (i.e., power, frequency, etc.). *No filing with the commission is required for a Class I permissive change.*

ACSS Proprietary	Use or disclosure of the information on this sheet is subject to the proprietary notice on the title page.	Page-14
---------------------	---	---------

Document Number 8020133-001	NGT-9000D FCC Test Procedures and Results	Revision -
--------------------------------	---	---------------

- A Class II permissive change includes those modifications that degrade the performance characteristics as reported to the commission at the time of initial certification.

#### **4.5 NGT-9000D Model to be Subjected to FCC Compliance Testing**

The NGT-9000D panel mount unit (9029000-20000 REV J) will be subjected to the full suite of FCC compliance tests with the resulting data submitted to the FCC for certification.

##### **4.5.1 Conclusion**

The full suite of FCC compliance tests will be performed on a NGT-9000D model. Test data from the NGT FCC compliance test will be submitted to the FCC to apply for a new certification and FCC identifier for the NGT-9000D unit.

## 5 EQUIPMENT AND SETUP

### 5.1 Test Facilities

FCC testing will be performed at the following facilities:

DNB Engineering, Inc.  
5969 Robinson Ave  
Riverside, CA 92503

### 5.2 Test Equipment

The test equipment used, are listed in each test results section below.

#### 5.2.1 Setup Block Diagram

Setup block diagrams are shown in each test results section below.

### 5.3 LRU Setup

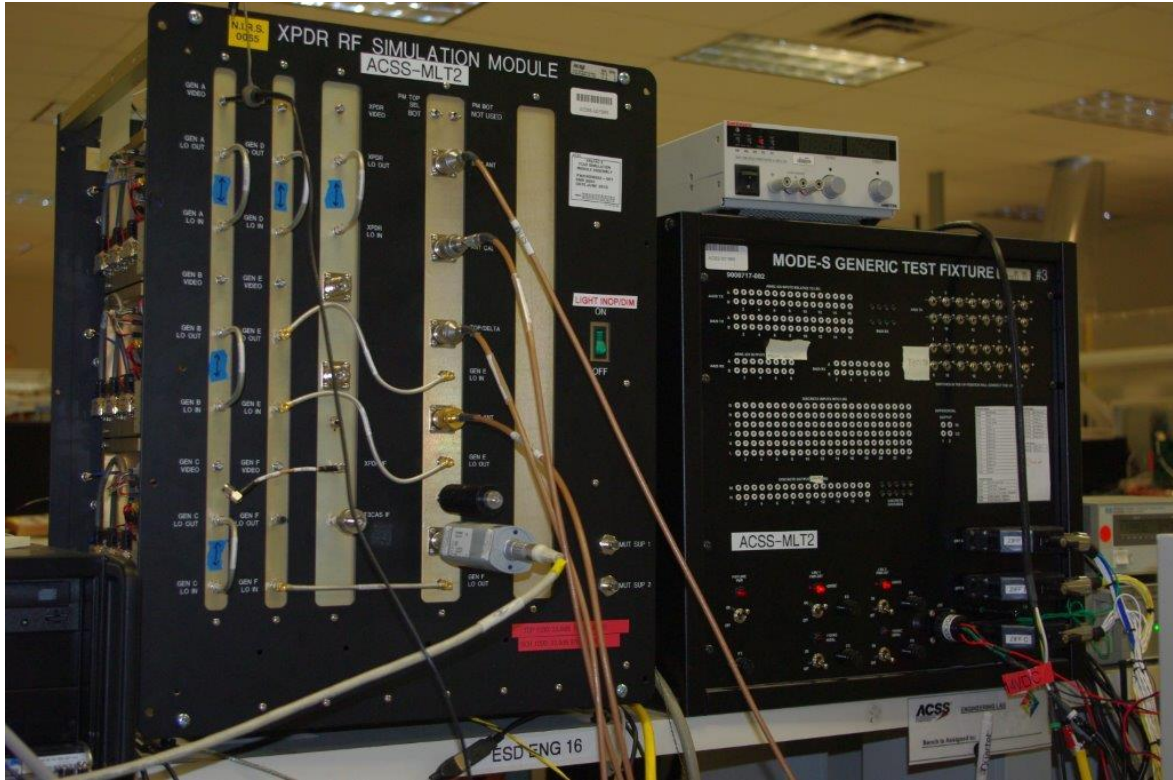
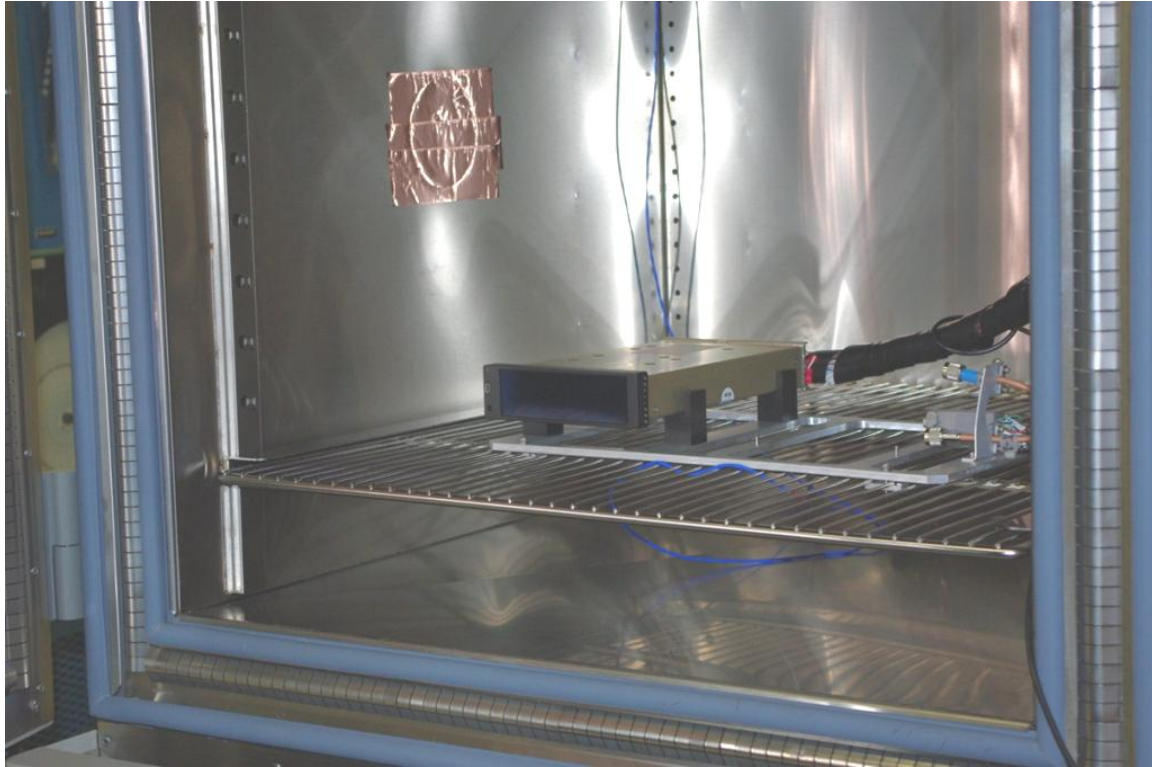

Figure 5-1: Test Equipment Setup



**Figure 5-2: NGT-9000D inside the Temperature Chamber**

**5.3.1 Hardware Configuration**

Testing was conducted on a single NGT-9000D LRU P/N 9029000-20000, S/N Q00007.

**5.3.2 Software Configuration**

The part number of the software, which was used for testing, are shown in Table 5-1.

**Table 5-1: NGT9000D+ Software**

Software	Part Number
Operational	8010-17000-0008
Maintenance	8010-17001-0008
Firmware (FPGA)	8000-17000-0004
Bootloader	8010-14020-0302
GPS/UAT Composite	RL98005-024
GPS/UAT Receiver	RL980001-024
GPS/UAT Firmware (FPGA)	RL9021120-024
GPS/UAT Bootloader	RL9001962-001
Airport Database	8010-22310-0201
Map Database	8010-12004-0001

## 5.4 Photographs

Photographs of the test equipment will be included in the FCC Compliance Test Report.



**Figure 5-3: NGT-9000D Front View**





Figure 5-4: NGT-9000D Rear View

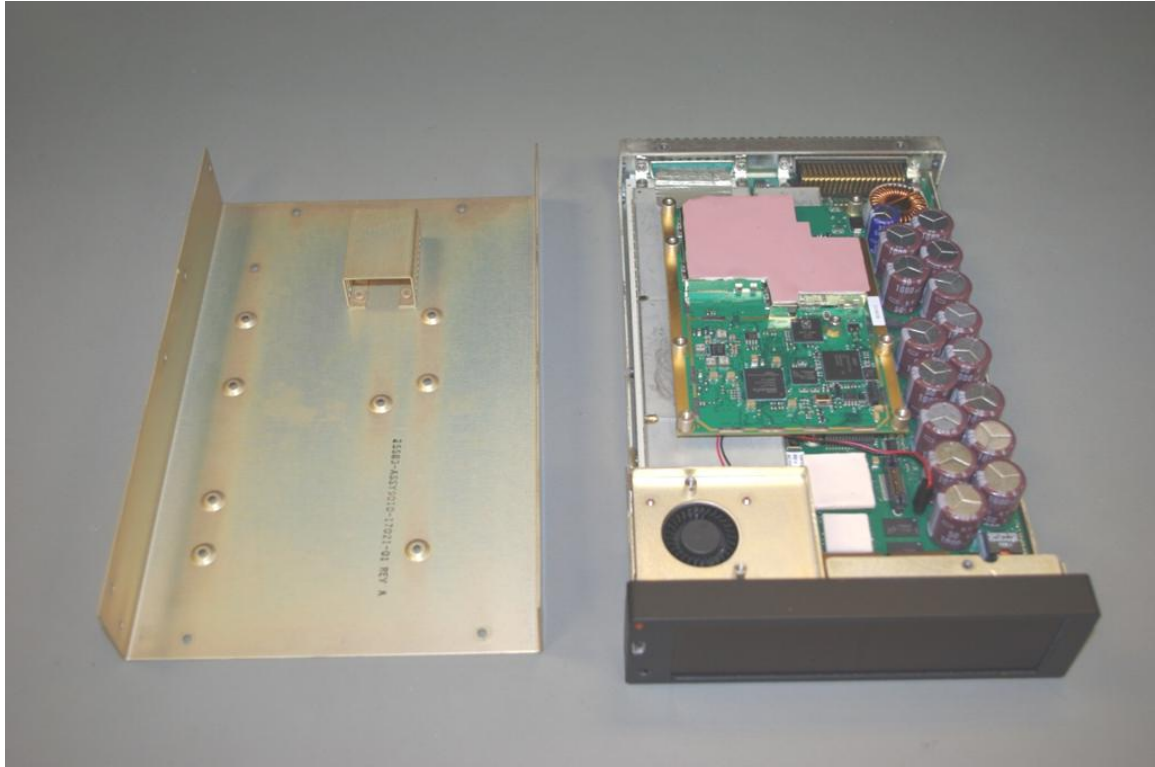
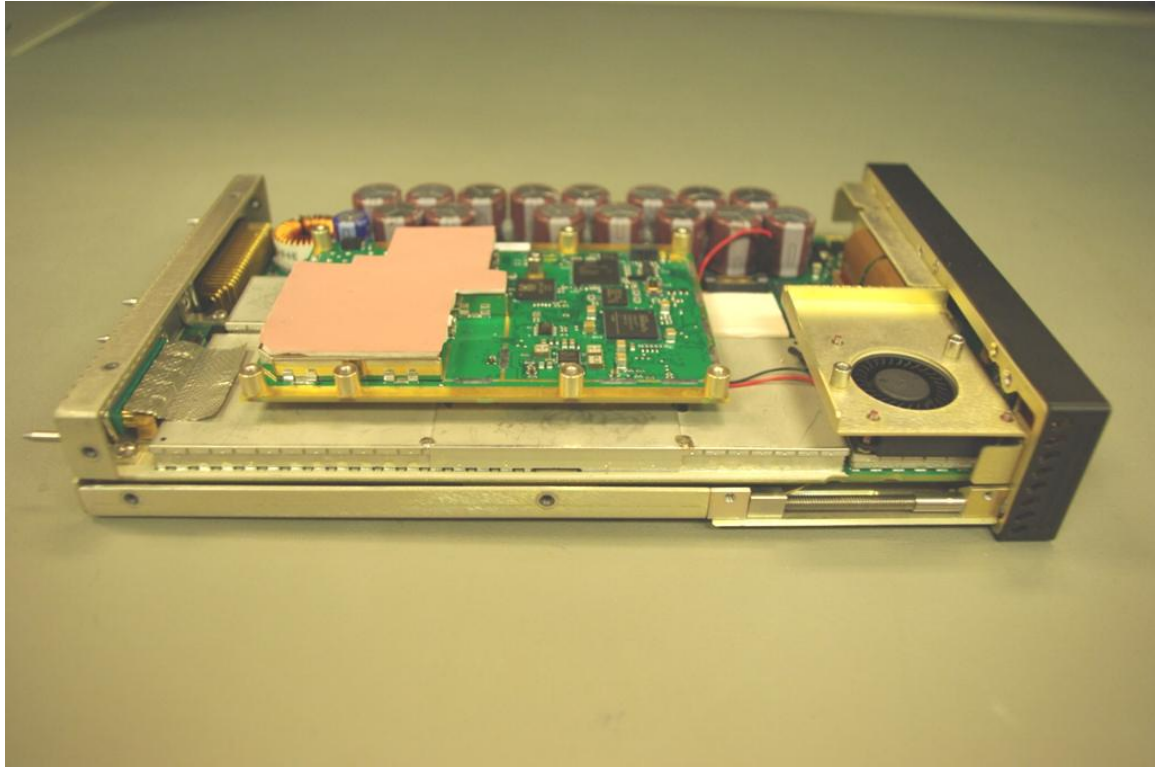

Figure 5-5: NGT-9000D Top View with Top Cover Removed



**Figure 5-6: NGT-9000D Side View With Top Cover Removed**

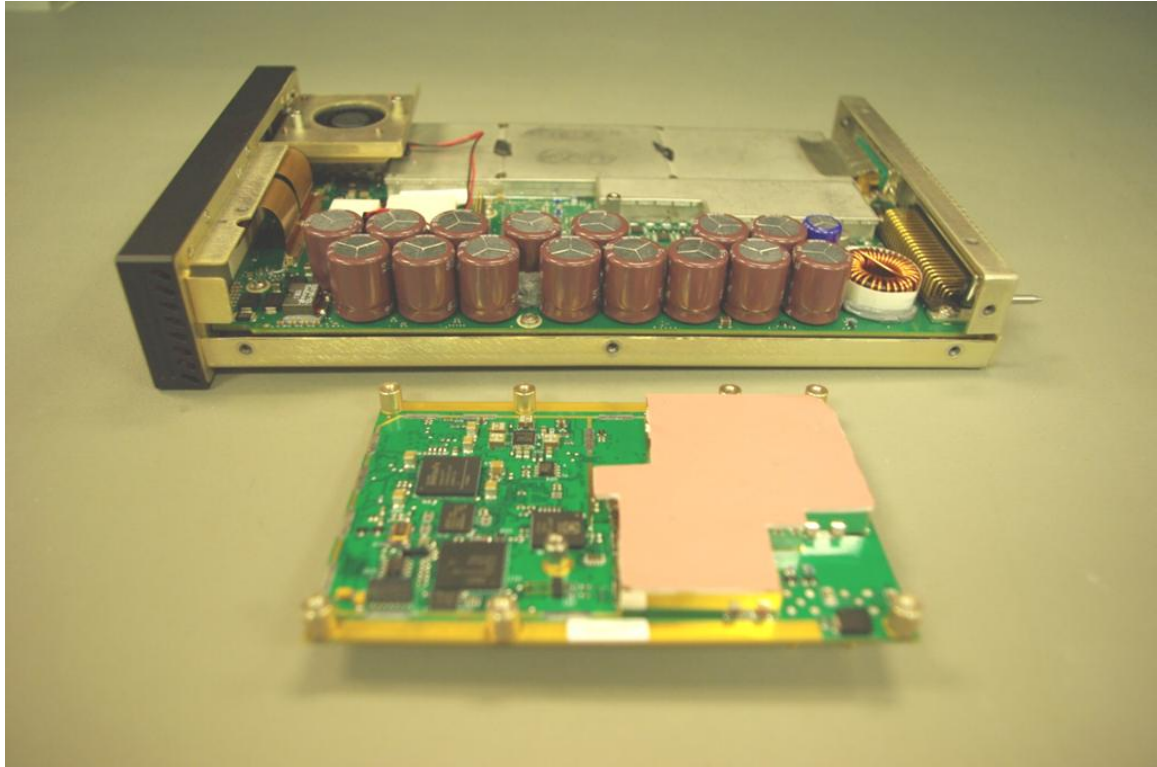

Figure 5-7: NGT-9000D with GPS-UAT CCA Removed

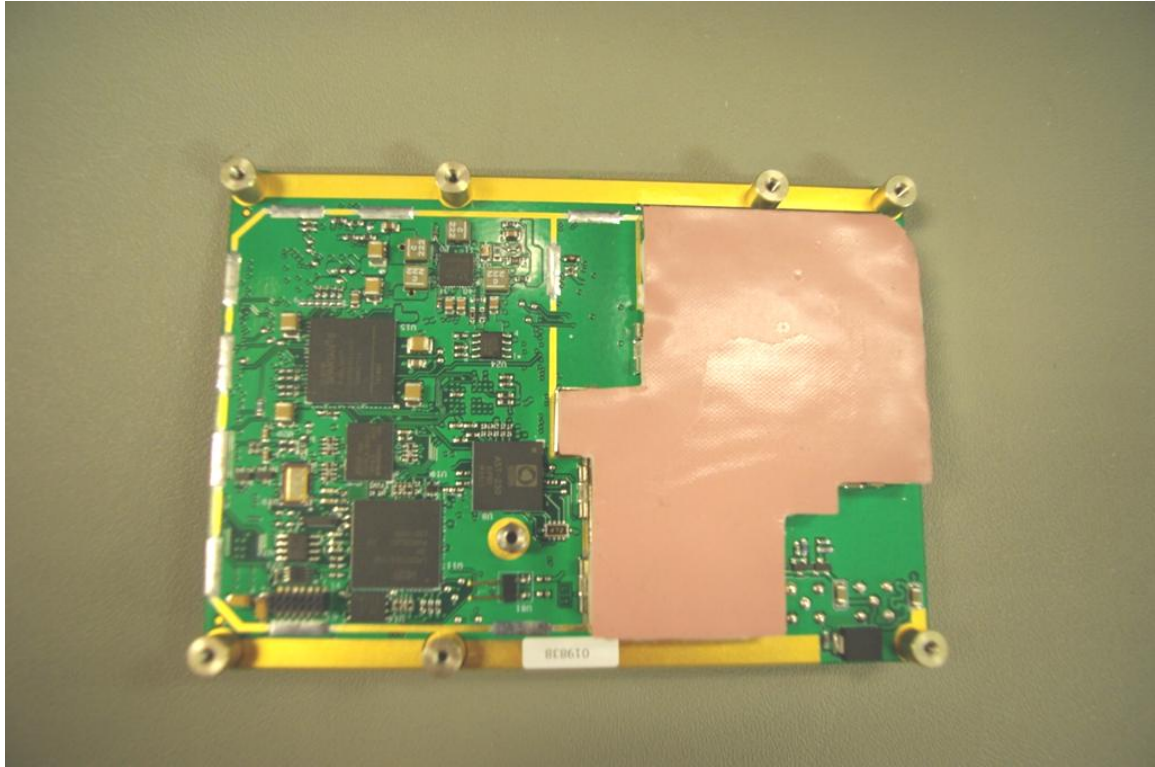

Figure 5-8: GPS-UAT CCA Top Side



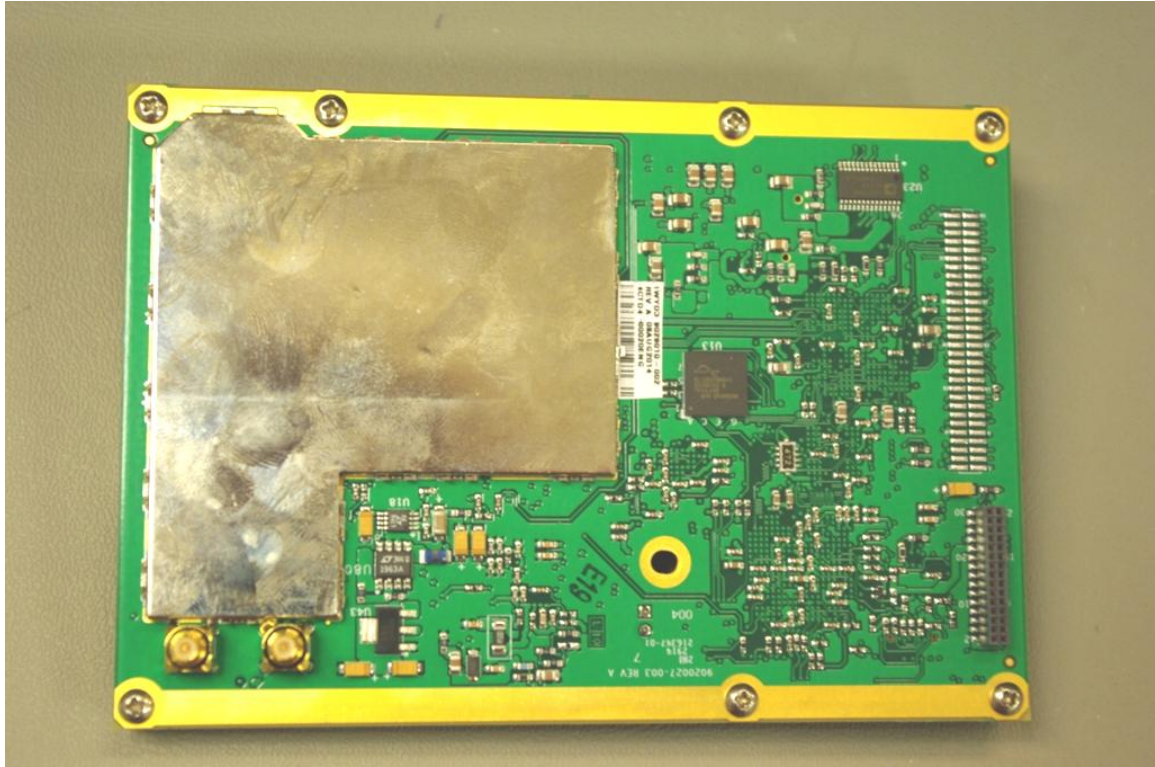

Figure 5-9: GPS-UAT CCA Bottom Side

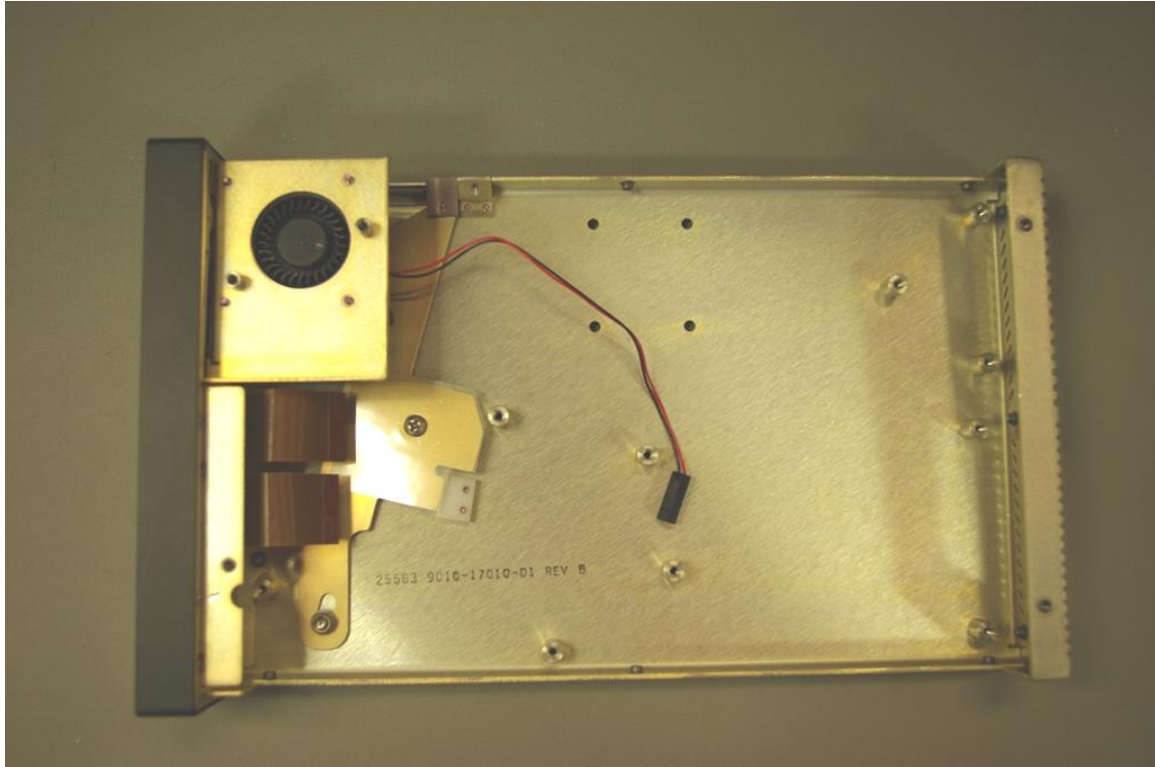

Figure 5-10: NGT-9000D with GPS-UAT CCA and Main CCA Removed

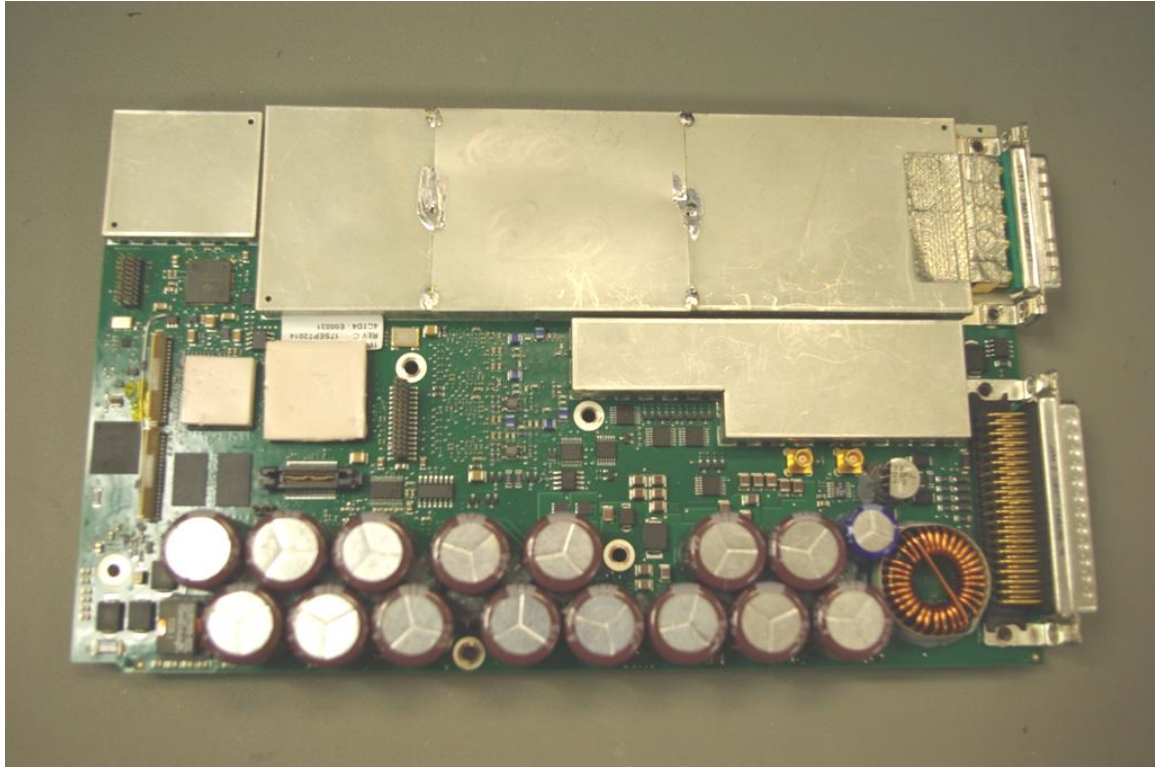

Figure 5-11:NGT-9000D Main CCA Top Side



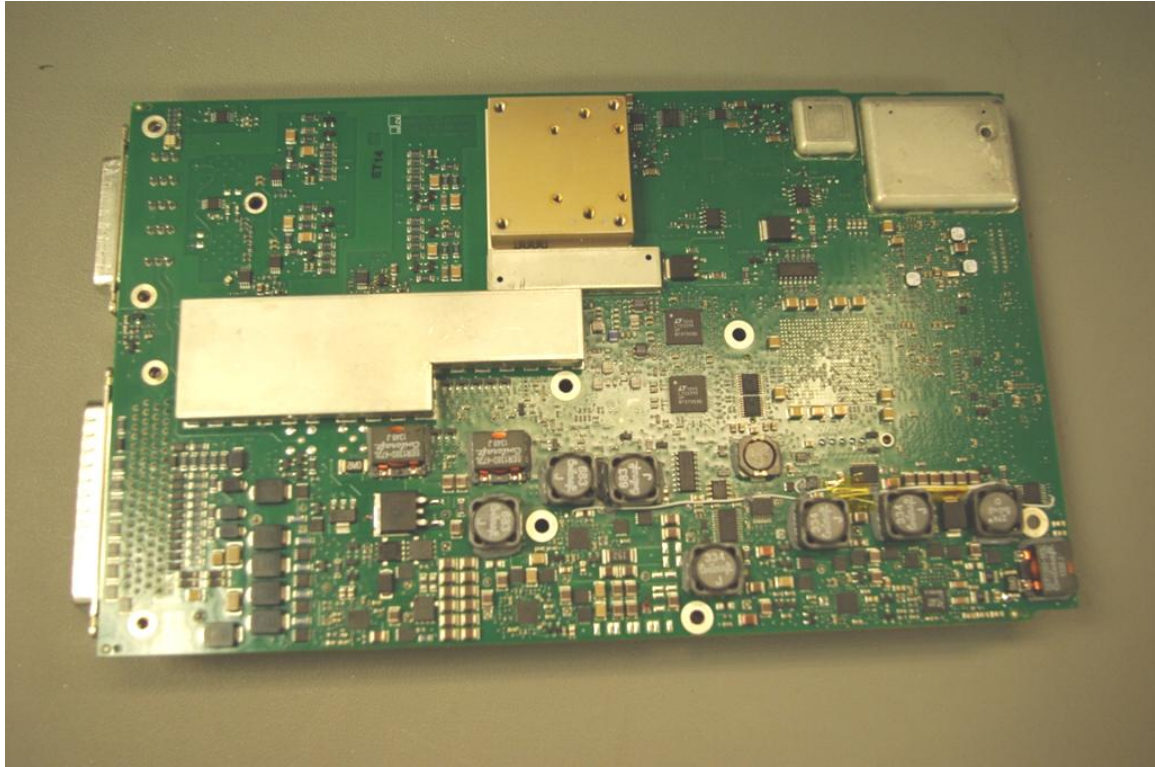

Figure 5-12: NGT-9000D Main CCA Bottom Side

Document Number 8020133-001	NGT-9000D FCC Test Procedures and Results	Revision -
--------------------------------	---	---------------

## 6 TEST SCHEDULE

FCC testing will commence in December of 2014.

Document Number 8020133-001	NGT-9000D FCC Test Procedures and Results	Revision -
--------------------------------	---	---------------

## 7 FCC COMPLIANCE TEST PROCEDURES

47CFR2.1041 states that for equipment operating under parts 15 & 18, the measurement procedures are specified in the rules governing the particular device for which certification is requested. For equipment operating in the authorized radio services, measurements are required as specified in sections 2.1046 (RF Power Output), 2.1047 (Modulation Characteristics), 2.1049 (Occupied Bandwidth), 2.1051 (Spurious Emissions at Antenna Terminals), 2.1053 (Field Strength of Spurious Radiation), 2.1055 (Frequency Stability) and 2.1057 (Frequency Spectrum to be Investigated).

### 7.1 RF Power Output

47CFR Reference:  
2.1046, RF Power Output  
87.131, Bandwidth of Emission

Given that the maximum power output of the transmitter located inside the NGT-9000D unit ranges from 1.7 W to 350 W at the rear of the unit, the transmitter's peak power output in dBm is calculated as follows:

$$P_{\text{peak\_Max}} \text{ (dBm, 1090 MHz)} = 10\text{Log}_{10}(P_{\text{peak}}, \text{ W} \times 1000\text{mW/W})$$

$$P_{\text{peak\_Max}} \text{ (dBm, 1090 MHz)} = 10\text{Log}_{10}(350 \text{ W} \times 1000\text{mW/W})$$

$$P_{\text{peak\_Max}} \text{ (dBm, 1090 MHz)} = 55.4 \text{ dBm}$$

$$P_{\text{peak\_Min}} \text{ (dBm, 1030 MHz)} = 10\text{Log}_{10}(P_{\text{min}}, \text{ W} \times 1000\text{mW/W})$$

$$P_{\text{peak\_Min}} \text{ (dBm, 1030 MHz)} = 10\text{Log}_{10}(350 \text{ W} \times 1000\text{mW/W})$$

$$P_{\text{peak\_Min}} \text{ (dBm, 1030 MHz)} = 55.4 \text{ dBm}$$

The transmitter's measured peak power output should be approximately 54 dBm (250 W) at the rear of the unit, considering manufacturing tolerances, measurement equipment tolerances and losses in any cables/connectors.

*Comment: In this report, the LRU's output power may be referenced in two separate locations, at the antenna or at the rear of the unit. Per Installation Manual, a loss of 1.5dB from the LRU to the aircraft antenna can be assumed. Therefore, when power is referenced to the rear of the LRU, the RF output power at the aircraft antenna can be assumed to be 1.5dB lower than the recorded power.*

#### 7.1.1 RF Power Output Test Equipment Required

**Table 7-1: RF Power Output Test Equipment Required**

Block Diagram Reference	Type	Manufacturer	Model
A	NGT-9000D LRU	ACSS	9029000-20000
B	NGT VALFAC	ACSS	9006052-001 and 9000717-002
C	Attenuator (or Equivalent)	Narda	765-20
D	Attenuator (or Equivalent)	Narda	765-20
E	Peak Power Meter	Boonton	4500B
F	Spectrum Analyzer	Agilent	N9020A

*Comment: Equivalent equipment may be used.*

### 7.1.2 RF Power Output Test Setup

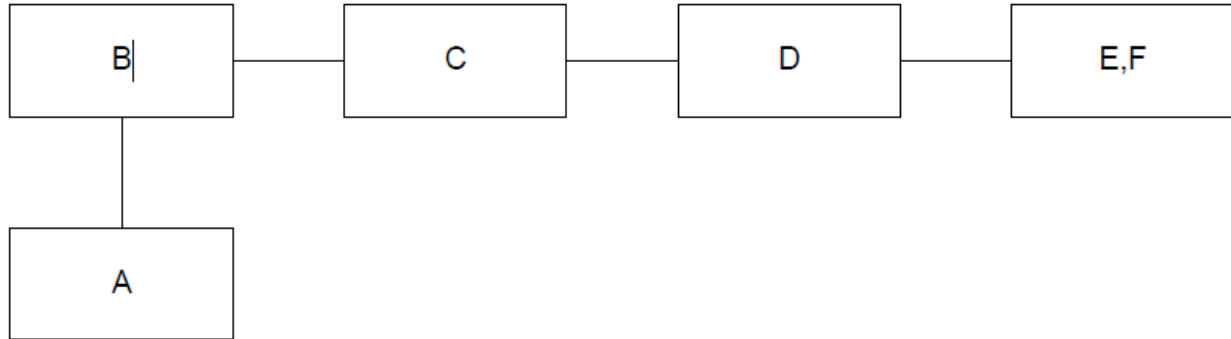

Figure 7-1: RF Power Output Test Setup

### 7.1.3 RF Power Output Test Procedure

1. Connect the equipment as shown in Figure 7-1 above.
2. For TAS measurements; open Serial Terminal on the VALFAC and connect to Com 1 at 115200 baud and activate to send the commands below. This enables the highest power W/S step at 50 Hz.
  - Testmode Set 3
  - TCAS WS 7 C
3. For XPDR measurements configure the VALFAC script tool to run:
  - DO181E\_23221\_modes\_top.scp, DO181E\_23221\_modes\_bot.scp (Mode S, Long DF-20 replies at 50 Hz on top/bottom antennas, respectively)
  - DO181E\_23221\_atcrbs\_top.scp and DO181E\_23221\_atcrbs\_bot.scp (ATCRBS, Mode A replies at 500 Hz on top/bottom antennas with Mode A code set to 0xFFFF).
4. Record the measured output power and frequency using the Peak Power Analyzer and Spectrum Analyzer.

### 7.1.4 Test Result Data

The peak power measured is mentioned in Table 7-2. For DNB Results see Appendix A. The power levels below are referenced at the rear of the unit; the limits are adjusted to account for the cable loss.

Table 7-2: NGT-9000D Peak power output

Modulation Characteristic		NGT-9000D Peak power output and frequency			Limit
		Measurement	Top antenna	Bottom antenna	
TAS	ATCRBS	Power Output (dBm)	52.5	N/A	$\geq 50\text{dBm}, < 54\text{dBm}$
		Frequency (MHz)	1030.0	N/A	$1030\text{ MHz} \pm 0.2\text{ MHz}$
XPDR	ATCRBS	Power Output (dBm)	52.7	52.8	$\geq 52.5\text{dBm}$
		Frequency (MHz)	1090.0	1090.0	$1090\text{ MHz} \pm 1\text{ MHz}$
	Mode S	Power Output (dBm)	52.8	53	$\geq 52.5\text{dBm}$

Document Number 8020133-001	NGT-9000D FCC Test Procedures and Results	Revision -
--------------------------------	---	---------------

		NGT-9000D Peak power output and frequency			Limit
Modulation Characteristic		Measurement	Top antenna	Bottom antenna	
		Frequency (MHz)	1090	1090	1090 MHz ± 1 MHz

## 7.2 Modulation Characteristics

47CFR Reference:  
2.1047, Modulation Characteristics  
87.141c, Modulation Requirements

### 7.2.1 Modulation Characteristics Test Equipment Required

Table 7-3: Modulation Characteristics Test Equipment Required

Block Diagram Reference	Type	Manufacturer	Model
A	NGT-9000D Test Unit	ACSS	9092000-20000
B	NGT VALFAC	ACSS	9006052-001 and 9000717-002
C	Attenuator	Narda	765-20
D	Attenuator	Narda	765-20
E	Peak Power Meter	Boonton	4500B

*Comment: Equivalent equipment may be used.*

### 7.2.2 Modulation Characteristics Test Setup

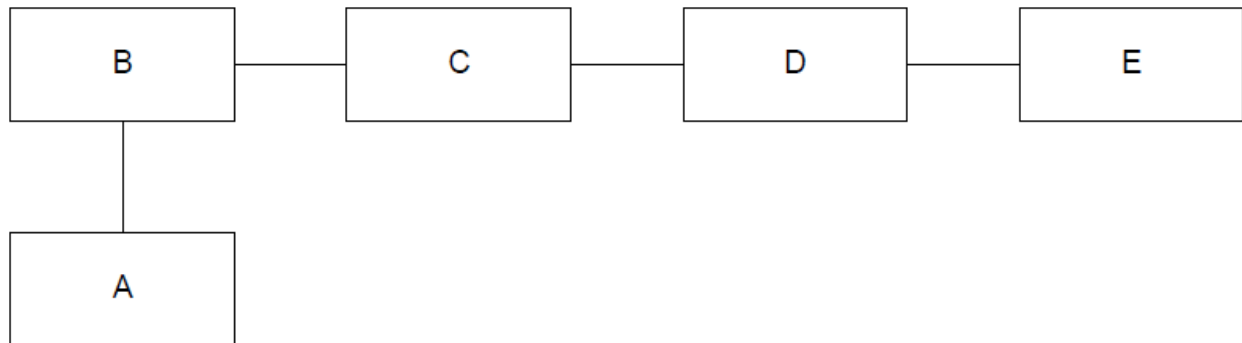

Figure 7-2: Modulation Characteristics Test Setup

### 7.2.3 Modulation Characteristics Test Procedure

1. Connect the equipment as shown in Figure 7-2 above.

#### For Transponder Modulation Characteristics:

2. For Transponder Modulation Configure the VALFAC script tool to run DO181E\_23221\_modes\_top.scp, DO181E\_23221\_modes\_bot.scp (Mode S, Long DF-20 replies)

ACSS Proprietary	Use or disclosure of the information on this sheet is subject to the proprietary notice on the title page.	Page-31
---------------------	--	---------

Document Number 8020133-001	NGT-9000D FCC Test Procedures and Results	Revision -
--------------------------------	---	---------------

at 50 Hz on top/bottom antennas, respectively), DO181E\_23221\_atcrbs\_top.scp, and DO181E\_23221\_atcrbs\_bot.scp (ATCRBS, Mode A replies at 500 Hz on top/bottom antennas, Mode A code set to 0xFFFF).

**For TAS Modulation Characteristics:**

3. Open the serial terminal window and connect to Com 1 at 115200 baud.
4. Activate the terminal and type, "testmode set 3"
5. Enter the following command, "tcas ws 7c" for a 50 Hz transmission of the highest power Mode C interrogation (P1 and P3, see Section 3.1).
6. Next, enter the following command, "tcas ws 7t" for a 50 Hz transmission of the highest power Mode C interrogation (S1, P1, and P3, see Section 3.1).
7. Record the modulation characteristics on the Peak Power Meter. Capture pictures of the following data to be shown in the test report:
  - Typical ATCRBS or Mode S reply pulse showing rise and fall times.
  - Mode S reply with pulse position modulation
  - Close up of Mode S reply preamble
  - ATCRBS Mode C reply
  - Typical ATCRBS Mode C interrogation pulse showing rise and fall times.
  - ATCRBS Mode C Interrogation, with and without the S1 Pulse present

**Table 7-4: Signal Analyzer settings for modulation characteristics measurement**

Parameter Item/Function	Parameter Setting Value
Channel / Vertical Scale	5 dB/div
Channel / Vertical Center	40 dBm
Channel / Extensions / Corrections / dB Offset	41 dB
Channel / Extensions / Averaging	8
Time / Timebase (for pulse width, rise time, fall time, amplitude)	200 ns/div
Time / Timebase (for pulse spacing)	2 us/div
Time / Trigger Delay	0 us
Trigger / Trigger Mode	Normal
Trigger / Trigger Level	+40 dBm
Trigger / Trigger Slope	+
Measure / Freq Ch1	1.06 GHz

**7.2.4 Modulation Characteristics Test Results**

The measured modulation related parameters are mentioned in

Table 7-5 and Table 7-6. For screen captures and DNB results see Appendix A.

**Table 7-5: NGT-9000D TAS Modulation related parameter measurement**

NGT-9000D Modulation Characteristics of TAS Transmission	
Measurement	ATCRBS Mode C Top Antenna
Pulse Width	808.1 ns
Rise Time	83.29 ns

NGT-9000D Modulation Characteristics of TAS Transmission	
Measurement	ATCRBS Mode C Top Antenna
Fall Time	173.9 ns
Pulse Spacing	21 us
Pulse Amplitude	52.98 dBm

Table 7-6: NGT-9000D XPDR Modulation related parameter measurement

NGT-9000D Modulation Characteristics of XPDR Transmission	
Measurement	Mode S antenna port
Pulse Width	487.9 ns
Rise Time	101.5 ns
Fall Time	182.5 ns
Pulse Spacing	1 us
Pulse Amplitude	52.922 dBm

### 7.3 Occupied Bandwidth

47CFR Reference:

2.1049, Occupied Bandwidth

87.135, Bandwidth of Emission

Occupied bandwidth is defined in 47CFR2.1049 as *“the frequency bandwidth such that, below its lower and above its upper frequency limits, the mean powers radiated are each equal to 0.5 percent of the total mean power radiated by a given emission.”*

#### 7.3.1 Occupied Bandwidth Test Equipment Required

Table 7-7: Occupied Bandwidth Test Equipment Required

Block Diagram Reference	Type	Manufacturer	Model
A	NGT-9000D Test Unit	ACSS	9029000-20000
B	NGT VALFAC	ACSS	9006052-001 and 9000717-002
C	Attenuator (or Equivalent)	Narda	765-20
D	Attenuator (or Equivalent)	Narda	765-20
E	Spectrum Analyzer	Agilent	N9020A

*Comment: Equivalent equipment may be used.*

### 7.3.2 Occupied Bandwidth Test Setup

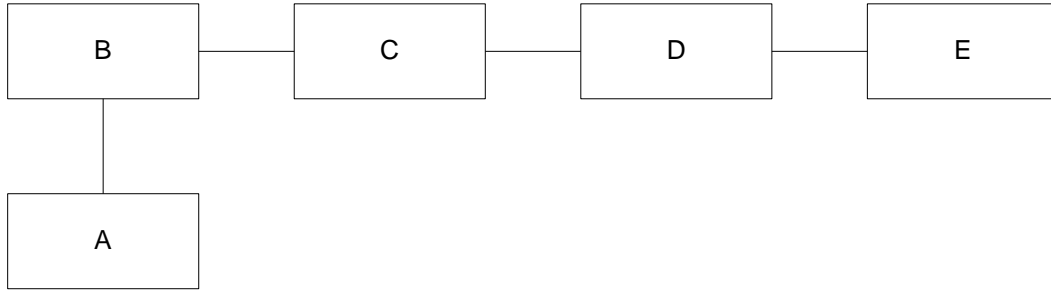

Figure 7-3: Occupied Bandwidth Test Setup

### 7.3.3 Occupied Bandwidth Test Procedure

1. Connect the equipment as shown in Figure 7-3 above.
2. Using the Spectrum analyzer, use the Occupied Bandwidth measurement function.
3. Set the center frequency to 1090 MHz, Span to 200 MHz, Resolution bandwidth to 2 MHz and Video bandwidth to 6 MHz.
4. Set the detector function to Average rms.
5. Select trace>>max hold and allow the window to fill up with the signal.
6. Record the occupied bandwidth in Table 7-8, below.

### 7.3.4 Occupied Bandwidth Test Results

The measured occupied bandwidth is mentioned in Table 7-8. For DNB results see Appendix A.

Table 7-8 Occupied Bandwidth

	NGT-9000D Occupied Bandwidth		
	Measurement	Top antenna	Bottom antenna
TAS	ATCRBS (MHz)	10.625 MHz	N/A
XPDR	Mode S (MHz)	10.625 MHz	10.65 MHz
	ATCRBS (MHz)	10.625 MHz	12.65 MHz

## 7.4 Spurious Emissions at Antenna Terminals

47CFR Reference:

2.1051, Spurious Emissions at Antenna Terminals

87.139, Emission Limitations

47CFR2.1051 states that the radio frequency voltages or powers generated within the equipment and appearing on a spurious frequency shall be checked at the equipment output terminals when properly loaded with a suitable artificial antenna.

47CFR2.1051 says that curves or equivalent data shall show the magnitude of each harmonic and other spurious emission that can be detected when the equipment is operated under the conditions specified in Sec 2.1049 (Occupied Bandwidth) as appropriate.



### 7.4.1 Spurious Emissions at Antenna Terminals Test Equipment Required

Table 7-9: Spurious Emissions at Antenna Terminals Test Equipment Required

Block Diagram Reference	Type	Manufacturer	Model
A	NGT-9000D Test Unit	ACSS	9029000-20000
B	NGT VALFAC	ACSS	9006052-001 and 9000717-002
C	Attenuator (or Equivalent)	Narda	765-20
D	Attenuator (or Equivalent)	Narda	765-20
E	Spectrum Analyzer	Agilent	N9020A

Comment: Equivalent equipment may be used.

### 7.4.2 Spurious Emissions at Antenna Terminals Test Setup

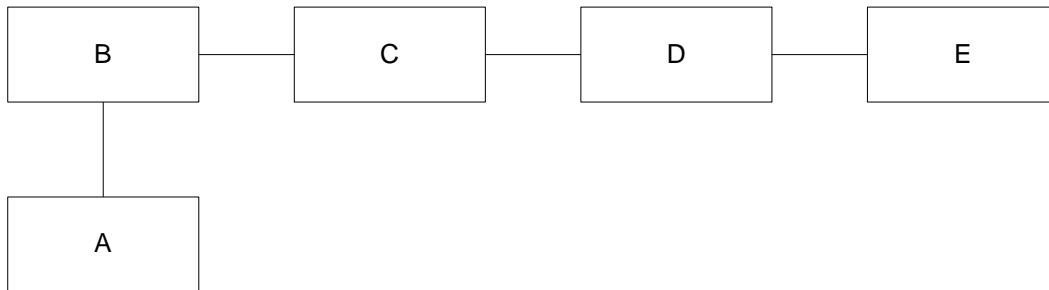

Figure 7-4: Spurious Emissions at Antenna Terminals Test Setup

### 7.4.3 Spurious Emissions at Antenna Terminals Test Procedure

1. Connect the equipment as shown in Figure 7-4 above.
2. For TAS measurements; open Serial Terminal on the VALFAC and connect to Com 1 at 115200 baud and activate to send the commands below. This enables the highest power W/S step at 50 Hz.
  - testmode set 3
  - tcas ws 7 C
3. For XPDR measurements configure the VALFAC script tool to run:
  - DO181E\_23221\_modes\_top.scp, DO181E\_23221\_modes\_bot.scp (Mode S, Long DF-20 replies at 50 Hz on top/bottom antennas, respectively)
  - DO181E\_23221\_atcrbs\_top.scp and DO181E\_23221\_atcrbs\_bot.scp (ATCRBS, Mode A replies at 500 Hz on top/bottom antennas with Mode A code set to 0xFF).
4. Measure and plot all spurs below 2000 MHz. Then measure each harmonic of 1030/1090 MHz up to 10<sup>th</sup> harmonic. Use a 300 kHz IF bandwidth on the Spectrum Analyzer.

### 7.4.4 Spurious Emissions at Antenna Terminals Test Results

For DNB results see Appendix A.

Document Number 8020133-001	NGT-9000D FCC Test Procedures and Results	Revision -
--------------------------------	---	---------------

## 7.5 Spurious Emissions at Antenna Terminals Local Oscillator Leakage (916 MHz)

### 7.5.1 Spurious Emissions at Antenna Terminals Local Oscillator Leakage (916 MHz) Test Equipment Required

**Table 7-10: Spurious Emissions at Antenna Terminals Local Oscillator Leakage (916 MHz) Test Equipment Required**

Block Diagram Reference	Type	Manufacturer	Model
A	NGT-9000D Test Unit	ACSS	9029000-20000
B	NGT VALFAC	ACSS	9006052-001 and 9000717-002
C	Spectrum Analyzer	Agilent	N9020A

*Comment: Equivalent equipment may be used.*

### 7.5.2 Spurious Emissions at Antenna Terminals Local Oscillator Leakage Test Setup

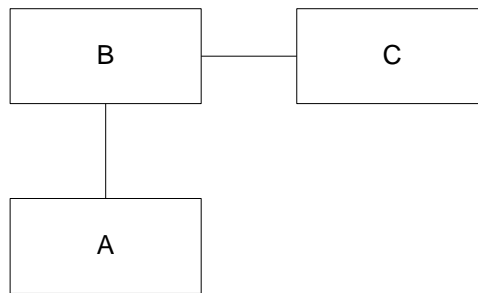

**Figure 7-5: Spurious Emissions at Antenna Terminals Local Oscillator Leakage Test Setup**

### 7.5.3 Spurious Emissions at Antenna Terminals Local Oscillator Leakage Test Procedure

- 1 Connect the equipment as shown in Figure 7-5 above.
- 2 Configure the spectrum analyzer for a center frequency of 916 MHz, 300 kHz IF bandwidth, and a span of 200 MHz
- 3 Configure the NGT-9000D transponder in standby mode.
- 4 Prior to performing the measurement, verify that the NGT-9000D is not transmitting.
- 5 Using a spectrum analyzer, measure and record the L.O. leakage out of the top and bottom antenna ports in Figure 7-5
- 6 Repeat the above measurements for the frequencies identified in Table 7-10

### 7.5.4 Spurious Emissions at Antenna Terminals Test Results

The LO Leakage data is shown below in Table 7-11 and Table 7-12.

**Table 7-11: Spurious Emissions at Top Antenna Terminal**

LO Leakage At Top Antenna Port	
Frequency (MHz)	Measured power (dBm)
916 (XPRD/TAS LO)	-74.163
1832 (2 <sup>nd</sup> Harmonic of LO frequency)	-74.070
907.4 (UAT LO)	-75.270
1814.8 (2 <sup>nd</sup> Harmonic of UAT LO)	-76.929
1567.236 (GPS LO)	-75.625

**Table 7-12: Spurious Emissions at Bottom Antenna Terminal**

LO Leakage At Bottom Antenna Port	
Frequency (MHz)	Measured power (dBm)
916 (XPRD/TAS LO)	-74.037
1832 (2 <sup>nd</sup> Harmonic of LO frequency)	-74.467
907.4 (UAT LO)	-75.115
1814.8 (2 <sup>nd</sup> Harmonic of UAT LO)	-76.496
1567.236 (GPS LO)	-76.221

## 7.6 Field Strength of Spurious Radiation

47CFR References:

2.1053, Field Strength of Spurious Radiation

15.109, Radiated Emission Limits

15.31, Measurement Standards

15.33, Frequency Range of Radiated Measurements

87.139, Emission Limitations

Per 47CFR15.109, the following limits on radiated emissions apply to the NGT-9000D units because it contains digital devices:

**Table 7-13: Allowable radiated emissions levels for units containing digital devices per 47CFR15.109**

Frequency (MHz)	Field Strength (microvolts/meter)	Measurement Distance (meters)
30 – 88	100	3
88 – 216	150	3
216 – 960	200	3
Above 960	500	3

47CFR15.31 para (i) states that the emission tests shall be performed with the device and accessories configured in a manner that tends to produce maximized emissions within the range of variations that can be expected under normal operating conditions. In order to accomplish this, the NGT-9000D will be operated in a maximum duty cycle mode of operation by running the VALFAC script DO181E\_23222.scp. This script interrogates the unit with 500 ATRBS, 50 Mode S short and 50 Mode S long interrogations per second.

Document Number 8020133-001	NGT-9000D FCC Test Procedures and Results	Revision -
--------------------------------	---	---------------

Per 47CFR15.33 para (a) (1), because the NGT-9000D operates below 10 Ghz, the 10<sup>th</sup> harmonic of the highest frequency or to 40 Ghz, whichever is lower, shall be used for the upper frequency of the measurement range.

47CFR15.33 para (b) (3) states that receivers employing super heterodyne techniques controlled by digital devices shall be investigated up to the higher of the 2<sup>nd</sup> harmonic of the highest local oscillator frequency generated in the device or the upper frequency of the measurement range of the digital device. Thus, a check for emissions at the first two harmonics of the fundamental frequency (916 Mhz) will be done.

### 7.6.1 Field Strength of Spurious Radiation Test Equipment Required

Table 7-14: Field Strength of Spurious Radiation Test Equipment Required

Block Diagram Reference	Type	Manufacturer	Model
A	NGT-9000D Test Unit	ACSS	9029000-20000
B	NGT VALFAC	ACSS	9006052-001 and 9000717-002
C	Termination	ATTA	N4425-10
D	Antenna, Biconical	Emco	3109
E	Antenna, Log Per.	Aprel	AL-2001
F	Antenna, Horn	Aprel	AH-118
G	Spectrum Analyzer	Hewlett-Packard	HP8566B
H	Preselector	Hewlett-Packard	85685A
I	Quasi-Peak	Hewlett-Packard	85650A

Comment: Equivalent equipment may be used.

### 7.6.2 Field Strength of Spurious Radiation Test Setup

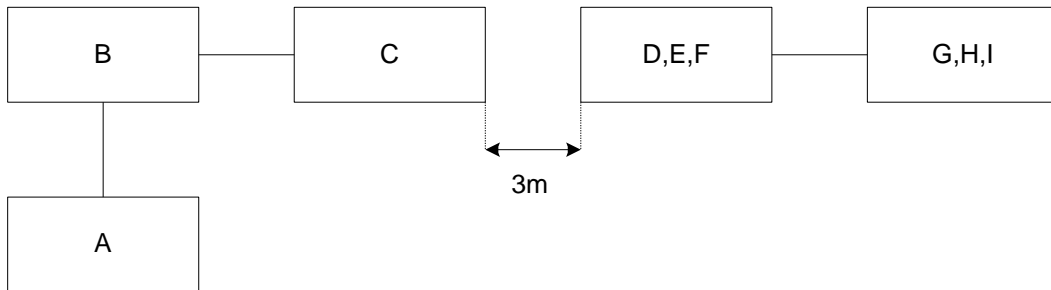

Figure 7-6: Field Strength of Spurious Radiation Test Setup

### 7.6.3 Field Strength of Spurious Radiation Test Procedure

1. Connect the equipment as shown in Figure 7-6, above.
2. Configure the VALFAC to Transmit TAS ATCRBS intruders (7 steps/second WS sequence) and Mode S Long replies at 50Hz.

Document Number 8020133-001	NGT-9000D FCC Test Procedures and Results	Revision -
--------------------------------	---	---------------

- To accomplish this, ensure the unit has a valid configuration and using the IFR interrogate the bottom antenna with Mode S at 50Hz.
3. Measure and record all spurious emissions using the appropriate antenna in the frequency ranges indicated in Table 7-13 at a distance of 3 meters.
  4. Calculate the field strength at 3m using the recorded power measurement, antenna factor and cable loss for each frequency.

## 7.6.4 Field Strength of Spurious Radiation Test Results

See Appendix A for DNB results.

## 7.7 Frequency Stability

### 7.7.1 Frequency Stability (Temperature Variation)

47CFR Reference:  
2.1055, Frequency Stability  
15.31, Measurement Standards  
87.133, Frequency Stability

#### 7.7.1.1 Frequency Stability (Temperature Variation) Test Equipment Required

Table 7-15: Frequency Stability (Temperature Variation) Test Equipment Required

Block Diagram Reference	Type	Manufacturer	Model
A	NGT-9000D Test Unit	ACSS	9029000-20000
B	NGT VALFAC	ACSS	9006052-001 and 9000717-002
C	Attenuator (or Equivalent)	Narda	765-20
D	Attenuator (or Equivalent)	Narda	765-20
E	Peak Power Analyzer	Agilent	N1911A
F	Spectrum Analyzer	Agilent	N9020A

*Comment: Equivalent equipment may be used.*

#### 7.7.1.2 Frequency Stability (Temperature Variation) Test Setup

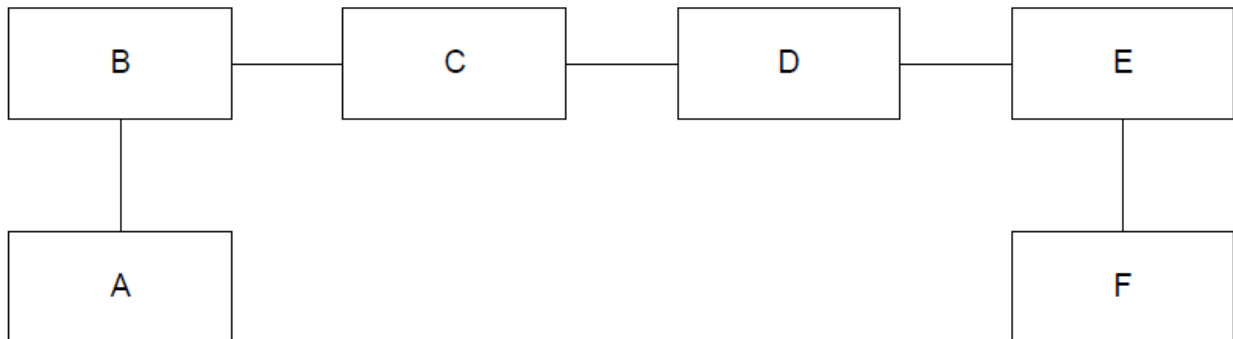

Figure 7-7: Frequency Stability (Temperature Variation) Test Setup for UAT Transmission

ACSS Proprietary	Use or disclosure of the information on this sheet is subject to the proprietary notice on the title page.	Page-39
---------------------	--	---------

### 7.7.1.3 TAS and Transponder Frequency Stability (Temp Variation) Test Procedure

- 1 Connect the equipment as shown in Figure 7-7 above.
- 2 For TAS measurements; open Serial Terminal on the VALFAC and connect to Com 1 at 115200 baud and activate to send the commands below. This enables the highest power W/S step at 50 Hz.
  - Testmode Set 3
  - TCAS WS 7 C
- 3 For XPDR measurements configure the VALFAC script tool to run:
  - DO181E\_23221\_modes\_top.scp, DO181E\_23221\_modes\_bot.scp (Mode S, Long DF-20 replies at 50 Hz on top/bottom antennas, respectively)
  - DO181E\_23221\_atcrbs\_top.scp and DO181E\_23221\_atcrbs\_bot.scp (ATCRBS, Mode A replies at 500 Hz on top/bottom antennas with Mode A code set to 0xFFFF).
- 4 Set the temperature chamber to - 20°C and allow the transmitter (non-operating) temperature to stabilize.
  - Allow for 30 min to let the unit stabilize at the operating low and high temperatures, for temperature steps in between allow for 10 minutes
- 5 Apply power to the unit and record the transmission frequency for both the top and bottom antennas.
- 6 Repeat steps 3 and 4 at -10°C, 0°C, +10°C, +20°C, +30°C, +40°C, and +55°C.
- 7 Record results in tables similar to Table 7-16 below.

### 7.7.1.4 TAS and Transponder Frequency Stability (Temperature Variation) Test Results

The transmission frequency offset and the peak power output values recorded during the temperature variation test are tabulated in Table 7-16 and

Table 7-17. See Appendix A for DNB Results.

**Table 7-16: Frequency Stability (Temperature Variation) Test Results TAS**

Temp Deg C	Top Antenna	
	Power Output (dBm)	Measured Frequency (MHz)
-20	53.2	1030.0
-10	52.9	1030.0
0	52.8	1030.0
10	53	1030.0
20	52.7	1030.0
30	52.3	1030.0
40	52.5	1030.0
55	52.4	1030.0
55	52.5	1030.0

**Table 7-17: Frequency Stability (Temperature Variation) Test Results XPDR**

Temp Deg C	Top Antenna		Bottom Antenna	
	Power Output (dBm)	Measured Frequency (MHz)	Power Output (dBm)	Measured Frequency (MHz)
-20	52.9	1090.0	53	1090.0
-10	52.5	1090.0	52.6	1090.0
0	52.5	1090.0	52.6	1090.0
10	52.4	1090.0	52.7	1090.0
20	52.7	1090.0	52.9	1090.0
30	52.1	1090.0	52.2	1090.0
40	52.1	1090.0	52.4	1090.0
50	52.9	1090.0	52.3	1090.0
55	52.3	1090.0	52.5	1090.0

### 7.7.2 Frequency Stability (Primary Power Variation)

47CFR references:

- 2.1055, Frequency Stability
- 15.31, Measurement Standards
- 87.133, Frequency Stability

47CFR15.31 (e) states that measurements of the radiated signal level of the fundamental frequency component of the emission shall be performed with the supply voltage varied between 85% and 115% of the nominal rated supply voltage.

For the 14 VDC power, 85%/115% = 11.9 VDC/16.1 VDC will be used

For the 28 VDC power, 85%/115% = 23.8 VDC/32.2 VDC will be used

#### 7.7.2.1 Frequency Stability (Primary Power Variation) Test Equipment Required

**Table 7-18: Frequency Stability (Primary Power Variation) Test Equipment Required**

Block Diagram Reference	Type	Manufacturer	Model
A	NGT-9000D Test Unit	ACSS	9029000-20000
B	NGT RF Module	ACSS	9006052-001
C	Attenuator	Narda	765-20
D	Attenuator	Narda	765-20
E	Spectrum Analyzer	Hewlett-Packard	HP8592L

*Comment: Equivalent equipment may be used.*

### 7.7.2.2 Frequency Stability (Primary Power Variation) Test Setup

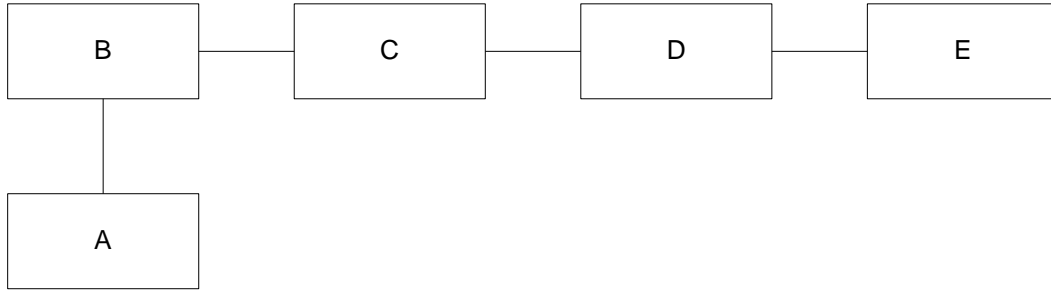

Figure 7-8: Frequency Stability (Primary Power Variation) Test Setup

### 7.7.2.3 TAS and Transponder Frequency Stability (Primary Power Variation) Test Procedure

- 1 Connect the equipment as shown in the block diagram above.
- 2 For TAS measurements; open Serial Terminal on the VALFAC and connect to Com 1 at 115200 baud and activate to send the commands below. This enables the highest power W/S step at 50 Hz.
  - Testmode Set 3
  - TCAS WS 7 C
- 3 For XPDR measurements configure the VALFAC script tool to run:
  - DO181E\_23221\_modes\_top.scp, DO181E\_23221\_modes\_bot.scp (Mode S, Long DF-20 replies at 50 Hz on top/bottom antennas, respectively)
  - DO181E\_23221\_atcrbs\_top.scp and DO181E\_23221\_atcrbs\_bot.scp (ATCRBS, Mode A replies at 500 Hz on top/bottom antennas with Mode A code set to 0xFF).
- 4 Apply +28VDC power to the unit and vary the primary power by +/-15% to the values shown in. Record the transmission frequency and power out for both the top and bottom antennas in Table 17.
- 5 Repeat step 3 for +14VDC power.

### 7.7.2.4 Frequency Stability (Primary Power Variation) Test Results

The transmission frequency offset and the peak power output values recorded during the primary power variation test are tabulated in Table 7-19. See Appendix A for DNB Results.

Table 7-19: Frequency Stability (Primary Power variation) Test Results

	Power Supply Voltage (V)	Top Antenna Port		Bottom Antenna Port	
		Measured Power Output (dBm)	Measured Frequency (MHz)	Measured Power Output (dBm)	Measured Frequency (MHz)
TAS	11.9	52.6	1030.0	N/A	N/A
	14	52.5	1030.0	N/A	N/A
	16.1	52.7	1030.0	N/A	N/A



		Top Antenna Port		Bottom Antenna Port	
	Power Supply Voltage (V)	Measured Power Output (dBm)	Measured Frequency (MHz)	Measured Power Output (dBm)	Measured Frequency (MHz)
	23.8	52.7	1030.0	N/A	N/A
	28	52.8	1030.0	N/A	N/A
	32.2	52.9	1030.0	N/A	N/A
XPDR	11.9	52.7	1090.0	53	1090.0
	14	52.7	1090.0	53	1090.0
	16.1	52.7	1090.0	53	1090.0
	23.8	52.7	1090.0	53.1	1090.0
	28	52.9	1090.0	53.1	1090.0
	32.2	52.9	1090.0	52.2	1090.0

Document Number 8020133-001	NGT-9000D FCC Test Procedures and Results	Revision -
--------------------------------	---	---------------

**APPENDIX A DNB TEST DATA – RIVERSIDE, CA**

# **Appendix A**

DNB Test Results - Riverside, CA

FCC Part 2, Part 15, Part 87

Model NGT-9000D

**FCC Part 2, Part 15, Part 87**

**Test Report  
for the**

**Diversity Mode-S Transponder**

Model # NGT-9000

Test Report Number RV58044-001

*Prepared For:*

ACSS, an L-3 Communications & Thales Company  
19810 N. 7th Avenue  
Phoenix, AZ 85027

*Prepared by:*

**DNB Engineering, Inc.  
5969 Robinson Avenue  
Riverside, CA 92503**

**NIST**

**NVLAP**<sup>®</sup>  
Lab Code: 200851-0





5969 Robinson Ave  
Riverside, CA 92503  
(951) 637-2630  
FAX (951) 637-2704  
www.dnbenginc.com

13 Jan 2015  
RV58044-001

## TABLE OF CONTENTS

<b>DOCUMENT HISTORY .....</b>	<b>3</b>
<b>CERTIFICATION OF TEST DATA.....</b>	<b>4</b>
<b>1.0 INTRODUCTION.....</b>	<b>6</b>
<b>2.0 DEVIATIONS .....</b>	<b>6</b>
<b>3.0 TEST SITE AND EQUIPMENT.....</b>	<b>7</b>
<b>4.0 TEST DESCRIPTION.....</b>	<b>7</b>
<b>5.0 CONCLUSIONS .....</b>	<b>9</b>
<b>APPENDIX A .....</b>	<b>10</b>
<b>APPENDIX B .....</b>	<b>12</b>
<b>APPENDIX C .....</b>	<b>18</b>

	<p>5969 Robinson Ave  Riverside, CA 92503  (951) 637-2630  FAX (951) 637-2704  www.dnbenginc.com</p>	<p>13 Jan 2015  RV58044-001</p>
---	--	-------------------------------------

## DOCUMENT HISTORY

<b>Revision</b>	<b>Number of Pages</b>	<b>Revised Pages</b>	<b>Description</b>	<b>Date</b>
-001	All	All	Report Release	13 Jan 2015



5969 Robinson Ave  
Riverside, CA 92503  
(951) 637-2630  
FAX (951) 637-2704  
www.dnbenginc.com

13 Jan 2015  
RV58044-001

## CERTIFICATION OF TEST DATA

This report, containing electromagnetic immunity and emissions test data and evaluations, has been prepared by an independent electromagnetic compatibility laboratory, DNB ENGINEERING, in accordance with the applicable specifications and instructions required per the Introduction. DNB Engineering has received accreditation to perform these tests by the following authorizations:

**NEMKO EMC Laboratory Authorization No. ELA 115A**  
**NIST / NVLAP: Lab Code No: 200851-0**

**FCC Registration No. 99985**

The data evaluation and equipment configuration presented herein are a true and accurate representation of the measurements of the test sample's electromagnetic immunity and emissions characteristics as of the dates and at the times of the test under the conditions herein specified.

This report shall not be reproduced, except in full, without the written approval of DNB ENGINEERING, INC. Results contained in this report relate only to the item tested.

Disclaimer: This report must not be used by the client to claim product certification, approval, or endorsement by NVLAP, NIST, or any agency of the Federal Government.

Report Prepared By: Maridee Winans *Maridee Winans* 13 Jan 2015  
Administrative Assistant Date

Report Reviewed by: Thomas Elders *Thomas Elders* 13 Jan 2015  
Facility Manager Date



5969 Robinson Ave  
 Riverside, CA 92503  
 (951) 637-2630  
 FAX (951) 637-2704  
 www.dnbenginc.com

13 Jan 2015  
 RV58044-001

FCC Part 2, Part 15, Part 87 Test Completion Record for:

ACSS, an L-3 Communications & Thales Company: **Diversity Mode-S  
 Transponder**  
 Model # NGT-9000

Test Start Date: 17 Dec 2014

Test Completion Date: 23 Dec 2014

*The EUT was tested in accordance with the requirements of the specifications and standards listed below and found to be fully compliant:*

**FCC 47 CFR Reference:**

- 2.1051, Spurious Emissions at Antenna Terminals
- 2.1053, Field Strength of Spurious Radiation
- 15.109, Radiated Emission Limits
- 87.139, Emission Limitations

<b>RF Power Output:</b>	Pass <input checked="" type="checkbox"/>	Fail <input type="checkbox"/>	N/A <input type="checkbox"/>
<b>Modulation Characteristics:</b>	Pass <input checked="" type="checkbox"/>	Fail <input type="checkbox"/>	N/A <input type="checkbox"/>
<b>Occupied Bandwidth:</b>	Pass <input checked="" type="checkbox"/>	Fail <input type="checkbox"/>	N/A <input type="checkbox"/>
<b>Spurious Emissions at Antenna Terminals:</b>	Pass <input checked="" type="checkbox"/>	Fail <input type="checkbox"/>	N/A <input type="checkbox"/>
<b>Frequency Stability:</b>	Pass <input checked="" type="checkbox"/>	Fail <input type="checkbox"/>	N/A <input type="checkbox"/>



5969 Robinson Ave  
Riverside, CA 92503  
(951) 637-2630  
FAX (951) 637-2704  
www.dnbenginc.com

13 Jan 2015  
RV58044-001

1.0

## **INTRODUCTION**

Electromagnetic Compatibility (EMC) tests were performed on a representative sample(s) of ACSS, an L-3 Communications & Thales Company, Diversity Mode-S Transponder, Model # NGT-9000. The purpose of this test was to demonstrate compliance of the EUT with the applicable limits. The test results have been summarized herein, and all data sheets have been incorporated in Appendix C.

Where applicable, cables were routed consistent with the typical application by varying the configuration of the test sample. The effect of varying the position of cables was investigated to find the configuration that produced maximum emissions and susceptibility.

The EUT was evaluated to determine the “worst case” positioning of both cables and axis. Once the “worst case” configuration was determined care was used to maintain this configuration throughout the test.

2.0

## **DEVIATIONS**

### **Deviations/Modifications to the EUT**

NONE

### **Deviations/Modifications from the Test Standards**

NONE





5969 Robinson Ave  
Riverside, CA 92503  
(951) 637-2630  
FAX (951) 637-2704  
www.dnbenginc.com

13 Jan 2015  
RV58044-001

3.0

## **TEST SITE AND EQUIPMENT**

The test equipment utilized in the performance of this test, along with current calibration information, is listed in the Test Equipment Log of Appendix A.

### **UNCERTAINTY TOLERANCE**

DNB Engineering's Riverside Facility is within acceptable uncertainty tolerances per ANSI C63.4 (2009) sections 5.4.6.1 and 5.4.6.2 as well as CISPR 16-1(2002) Annex L, section L.2.

ANSI C63.4 (2009)

5.4.6.1 Site Attenuation. A measurement site shall be considered acceptable for radiated electromagnetic field measurements if the horizontal and vertical NSA derived from measurements, i.e., the "measured NSA," are within +/- 4 dB of the theoretical NSA (5.4.6.3) for an ideal site.

5.4.6.2 NSA Tolerance. The +/- 4 dB tolerance in 5.4.6.1 includes instrumentation calibration errors, measurement technique errors, and errors due to site anomalies. These errors are analyzed in ANSI C63.6- 1998 [3], wherein it is shown that the performance of a well-built site contributes only 1 db of the total allowable tolerance.

CISPR 16-1 (2002)

L.2 Error analysis

...The total estimated errors are the basis for the +/- 4 dB site acceptability criteria consisting of approximately 3 dB measurement uncertainty and an additional allowable 1 dB for site imperfections.

This uncertainty represents an expanded uncertainty expressed at approximately the 95% confidence level using a coverage factor of  $k=2$ .

---



4.0

## **TEST DESCRIPTION**

4.2

### **Radiated RF Emissions (ANSI C63.4 2009)**

To measure radiated emissions, the EUT was set up on the 3 or 10-meter open air test site. The EUT is placed on a wooden table, which rests on a wooden turntable. The top of the table is one meter above the ground, and the turntable can be rotated 360 degrees. For each frequency measured, the antenna is raised and lowered for both horizontal and vertical polarities to obtain the maximum reading on the analyzer. The turntable is also rotated throughout the 360 degrees in azimuth to determine the position of the maximum emissions. The applicable frequency range is searched using the antennas listed below. The respective antenna and preamplifier were connected to an HP 8568B Spectrum Analyzer. Preamplifiers were used for all ranges to achieve the needed dynamic range. A list of the equipment used in this test is included in Appendix A. Photographs of this test set up are included in Appendix B.

Antenna(s):

- Electro-Metrics 6505-A (.009 - 30 MHz) [ ]
- SAS 200/540 BICONICAL (30 - 200 MHz) [X]
- EMCO 3146 LOG PERIODIC (200 - 1000 MHz) [X]
- EMCO 3115 DRG (1GHz – 18GHz) [X]
- OTHER (See Equipment Log in Appendix B) [X]

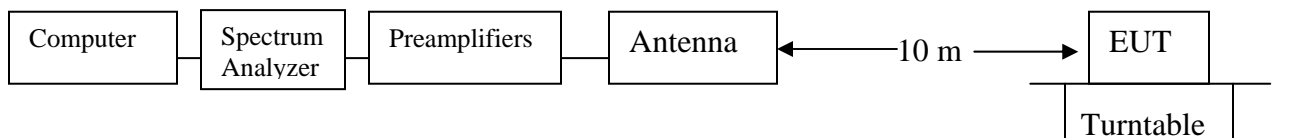



5969 Robinson Ave  
Riverside, CA 92503  
(951) 637-2630  
FAX (951) 637-2704  
www.dnbenginc.com

13 Jan 2015  
RV58044-001

5.0

## **CONCLUSIONS**

---

The ACSS, an L-3 Communications & Thales Company, Diversity Mode-S Transponder, Model #NGT-9000, was tested in accordance with the requirements listed herein. Pass/Fail status for each test is listed in Section 5.0. At the completion of testing the EUT and support equipment were returned to representatives of ACSS, an L-3 Communications & Thales Company.



5969 Robinson Ave  
Riverside, CA 92503  
(951) 637-2630  
FAX (951) 637-2704  
www.dnbenginc.com

13 Jan 2015  
RV58044-001

## **APPENDIX A**

*Test Equipment Log*



5969 Robinson Ave  
 Riverside, CA 92503  
 (951) 637-2630  
 FAX (951) 637-2704  
 www.dnbenginc.com

13 Jan 2015  
 RV58044-001

11	Antenna (Small DRG)	Emco	3115	2281	Riv	R	09-Jan-13	730	09-Jan-15	OK
31	Antenna (Log Periodic)	Emco	3146	1284	Riv	R	29-Jul-13	730	29-Jul-15	OK
364	Pre-Amp	Miteq	afd304008040	121391	Riv	R	24-Oct-14	365	24-Oct-15	OK
1233	Spectrum Analyzer	HP	8568B	2732A03600	Riv	R	24-Oct-14	365	24-Oct-15	OK
1234	Spec Analyzer Display	HP	85662A	2648A15552	Riv	R	24-Oct-14	365	24-Oct-15	OK
1430	RF Pre-Selector	H/P	85685A	2724A00659	Riv	R	24-Oct-14	365	24-Oct-15	OK
1698	Pre-Amp	Miteq	AFS4-08001800-35-LN	378064	Riv	R	23-Oct-14	365	23-Oct-15	OK
1758	Antenna (Bicon)	AH Systems	SAS-200/540	524	Riv	R	10-Sep-13	720	10-Sep-15	OK
1760	Pre-Amp (called ZFL)	Mini-Circuits	ZFL-2000	8350	Riv	R	22-Jan-14	365	22-Jan-15	OK
1874	Cable	DNB	Helix	11874	Riv	R	16-Aug-14	365	16-Aug-15	OK
1875	Cable	DNB	RG214	11875	Riv	R	16-Aug-14	365	16-Aug-15	OK
1880	Cable	DNB	NMN	11880	Riv	R	12-Aug-14	365	12-Aug-15	OK
1965	Quasi-Peak Adapter	HP	85650A	2043A00277	Riv	R	24-Oct-14	365	24-Oct-15	OK
2047	Directional Coupler	HP	5080-0312	1144A00274	Ful	R	21-Jul-14	365	21-Jul-15	OK
2264	Spectrum Analyzer	Agilent	E4407B	MY45103462	Riv	R	07-Aug-14	365	07-Aug-15	OK
3066	Directional Coupler	HP	11691D	1212A01914	Ful	F	31-Aug-14	365	31-Aug-15	OK
3635	Attenuator	Inmet	18N50W	13635	Ful	F	31-Aug-15	365	31-Aug-15	OK



5969 Robinson Ave  
Riverside, CA 92503  
(951) 637-2630  
FAX (951) 637-2704  
www.dnbenginc.com

13 Jan 2015  
RV58044-001

## **APPENDIX B**

*Photographs*



## Block diagram Test Setup

---

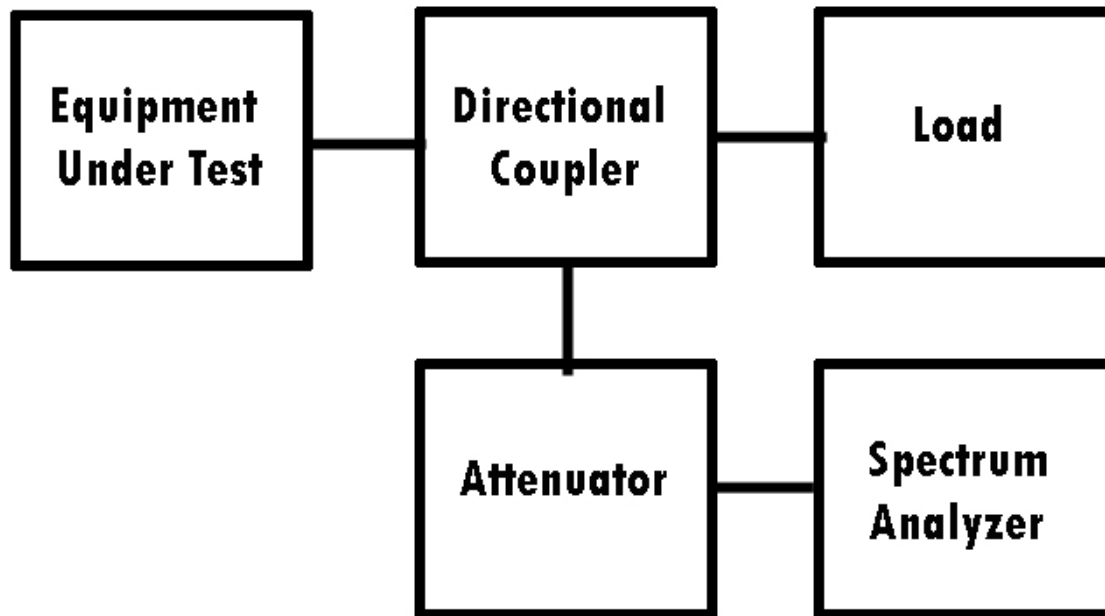



5969 Robinson Ave  
Riverside, CA 92503  
(951) 637-2630  
FAX (951) 637-2704  
www.dnbenginc.com

13 Jan 2015  
RV58044-001

## Photos

## Radiated Emissions-Bicon

Notes: 30MHz – 200 MHz







5969 Robinson Ave  
Riverside, CA 92503  
(951) 637-2630  
FAX (951) 637-2704  
www.dnbenginc.com

13 Jan 2015  
RV58044-001

## Photos

## Radiated Emissions-Bicon

Notes: 30MHz – 200 MHz





5969 Robinson Ave  
Riverside, CA 92503  
(951) 637-2630  
FAX (951) 637-2704  
www.dnbenginc.com

13 Jan 2015  
RV58044-001

## Photos

## Radiated Emissions – Log Periodic

Notes: 200MHz – 1000MHz







5969 Robinson Ave  
Riverside, CA 92503  
(951) 637-2630  
FAX (951) 637-2704  
www.dnbenginc.com

13 Jan 2015  
RV58044-001

## Photos

## Radiated Emissions – Log Periodic

Notes: 200MHz – 1000MHz





5969 Robinson Ave  
Riverside, CA 92503  
(951) 637-2630  
FAX (951) 637-2704  
www.dnbenginc.com

13 Jan 2015  
RV58044-001

## **APPENDIX C**

*Test Data*



5969 Robinson Ave  
 Riverside, CA 92503  
 (951) 637-2630  
 FAX (951) 637-2704  
 www.dnbenginc.com

13 Jan 2015  
 RV58044-001

### RF Power Output

DNB Job Number:	RV58044-001	Date:	Dec 17 2014	<b>Specification</b> FCC 47 CFR 2.1046 87.131
Customer:	ACSS, an L-3 Communications & Thales Company			
Model Number:	NGT-9000			
Description:	Diversity Mode-S Transponder	S/N:	N/A	
Test Equipment: (See pg. 11)	Asset #'s: 3635, 2047, 2264			
EUT performed within the requirements of the applicable Standard(s) YES <input checked="" type="checkbox"/> NO <input type="checkbox"/> SIGNED Thomas Elders				

Modulation		Measurement	Top Antenna	Bottom Antenna
TAS	ATCRBS	Power Output (dBm)	52.5	N/A
		Frequency (MHz)	1030	N/A
XPDR	Mode S	Power Output (dBm)	52.8	53
		Frequency (MHz)	1090	1090
	ATCRBS	Power Output (dBm)	52.7	52.8
		Frequency (MHz)	1090	1090



5969 Robinson Ave  
 Riverside, CA 92503  
 (951) 637-2630  
 FAX (951) 637-2704  
 www.dnbenginc.com

13 Jan 2015  
 RV58044-001

### Modulation Characteristics

DNB Job Number:	RV58044-001	Date:	Dec 18 2014	<b>Specification</b> FCC 47 CFR 2.1046 87.131
Customer:	ACSS, an L-3 Communications & Thales Company			
Model Number:	NGT-9000			
Description:	Diversity Mode-S Transponder	S/N:	N/A	
Test Equipment: (See pg. 11)	Asset #'s:2047, 3635, 15387, 1773			
EUT performed within the requirements of the applicable Standard(s) YES <input checked="" type="checkbox"/> NO <input type="checkbox"/> SIGNED Thomas Elders				

### ATCRBS Interrogation single pulse characteristics

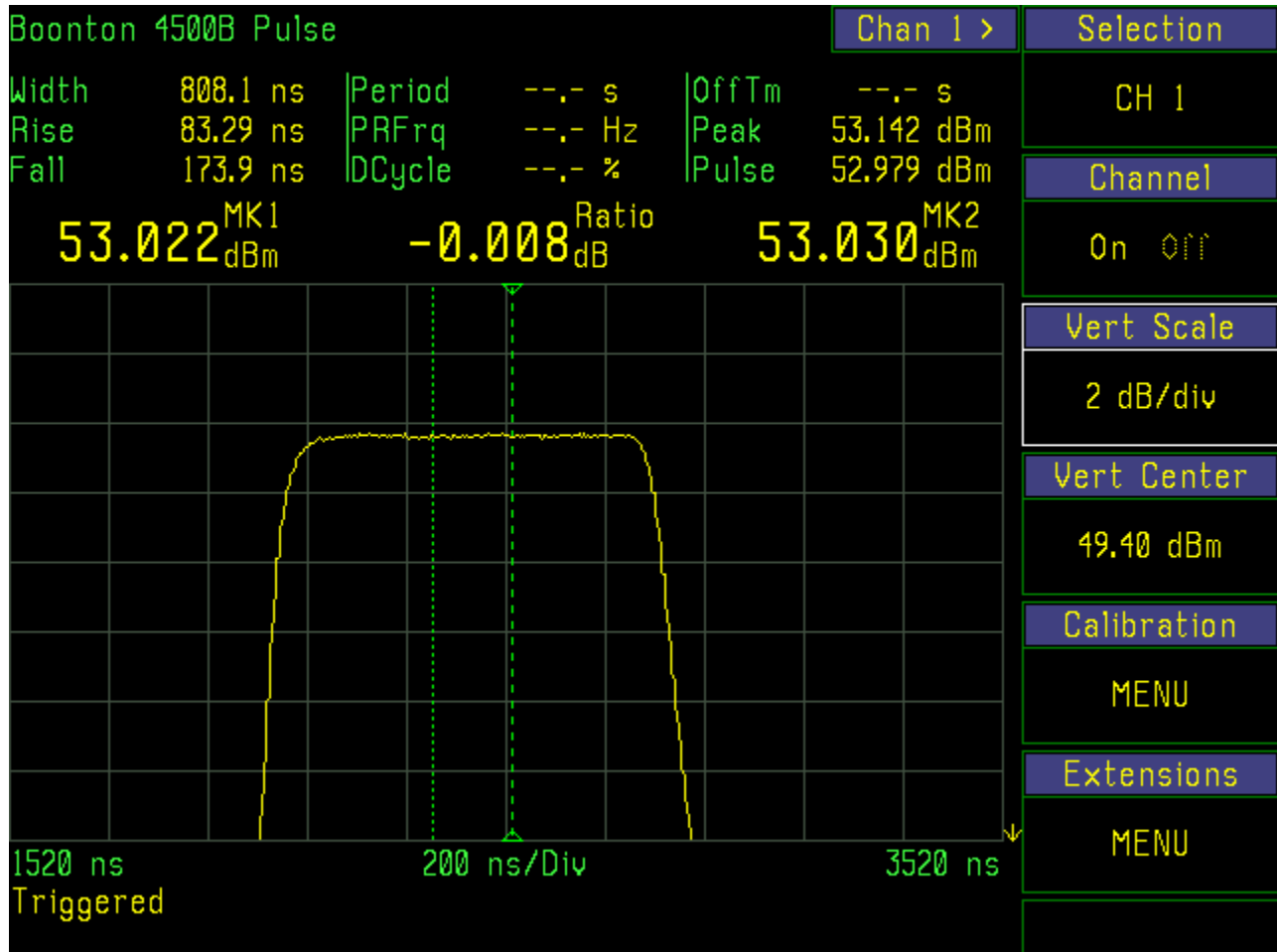



5969 Robinson Ave  
 Riverside, CA 92503  
 (951) 637-2630  
 FAX (951) 637-2704  
 www.dnbenginc.com

13 Jan 2015  
 RV58044-001

### Modulation Characteristics

DNB Job Number:	RV58044-001	Date:	Dec 18 2014	<b>Specification</b> FCC 47 CFR 2.1046 87.131
Customer:	ACSS, an L-3 Communications & Thales Company			
Model Number:	NGT-9000			
Description:	Diversity Mode-S Transponder	S/N:	N/A	
Test Equipment: (See pg. 11)	Asset #'s:2047, 3635, 15387, 1773			
EUT performed within the requirements of the applicable Standard(s) YES <input checked="" type="checkbox"/> NO <input type="checkbox"/> SIGNED Thomas Elders				

### ATCRBS Interrogation with S1

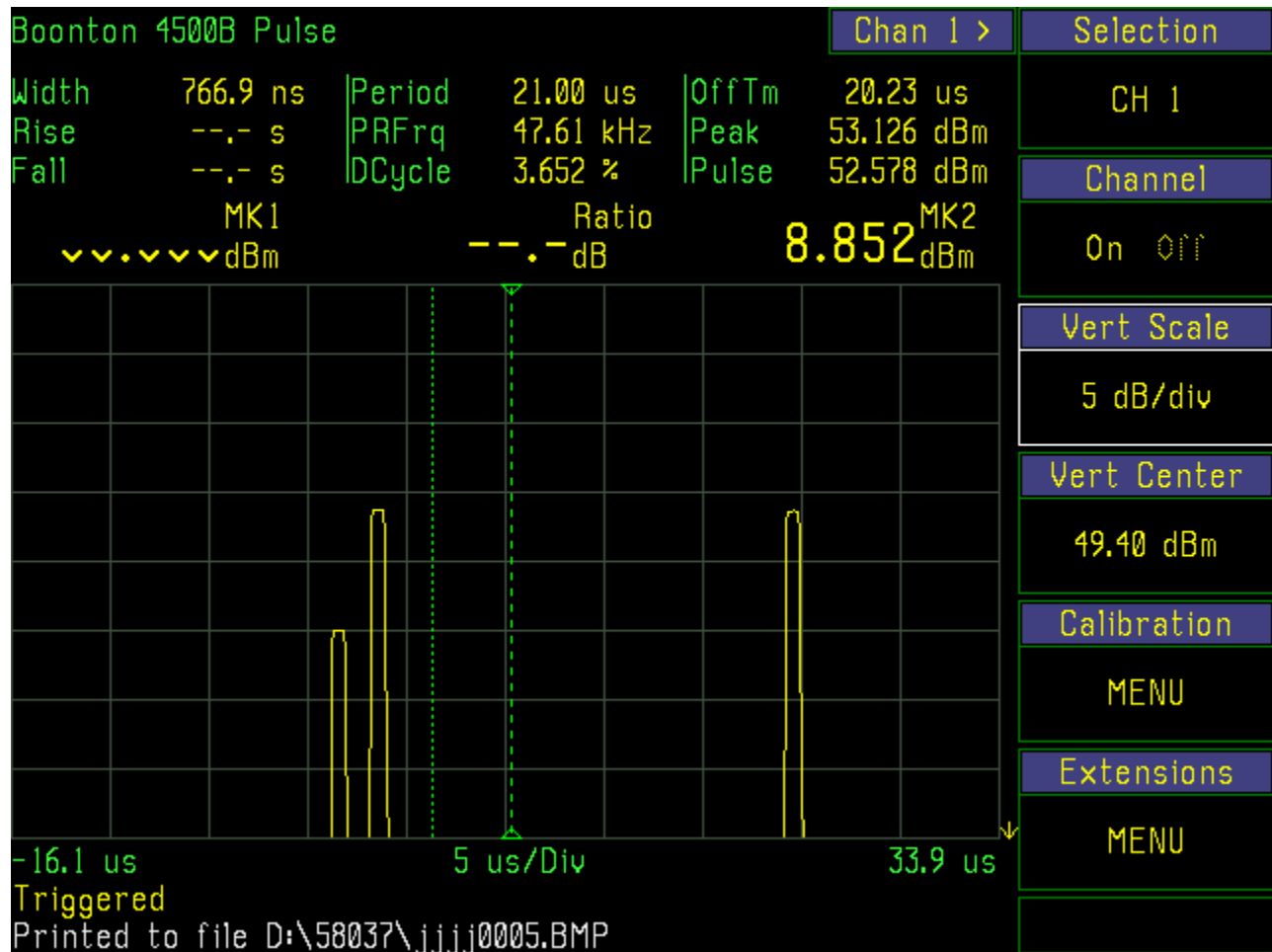



5969 Robinson Ave  
 Riverside, CA 92503  
 (951) 637-2630  
 FAX (951) 637-2704  
 www.dnbenginc.com

13 Jan 2015  
 RV58044-001

### Modulation Characteristics

DNB Job Number:	RV58044-001	Date:	Dec 18 2014	<b>Specification</b> FCC 47 CFR 2.1046 87.131
Customer:	ACSS, an L-3 Communications & Thales Company			
Model Number:	NGT-9000			
Description:	Diversity Mode-S Transponder	S/N:	N/A	
Test Equipment: (See pg. 11)	Asset #'s:2047, 3635, 15387, 1773			
EUT performed within the requirements of the applicable Standard(s) YES <input checked="" type="checkbox"/> NO <input type="checkbox"/> SIGNED Thomas Elders				

### ATCRBS interrogation without S1

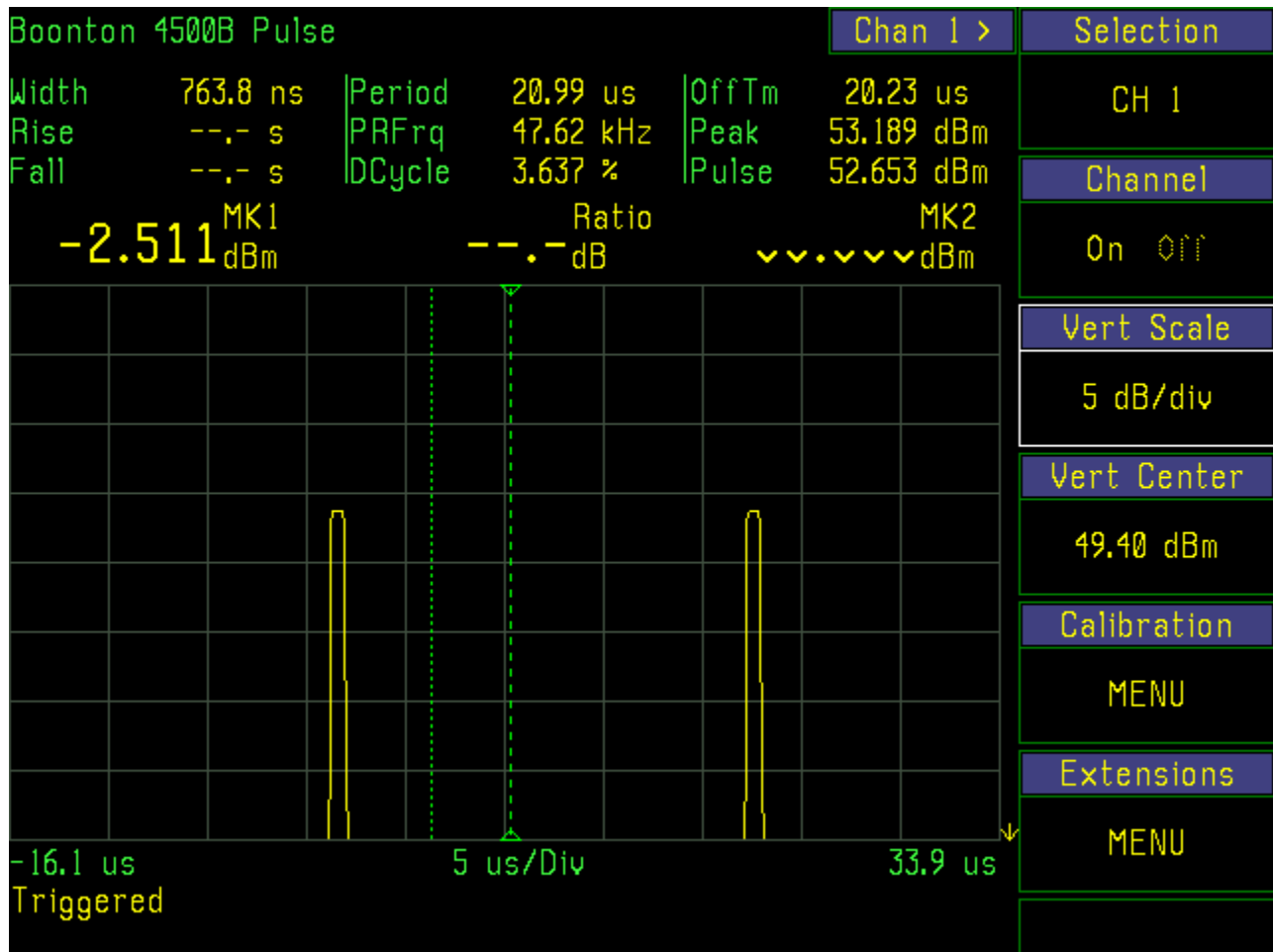





5969 Robinson Ave  
 Riverside, CA 92503  
 (951) 637-2630  
 FAX (951) 637-2704  
 www.dnbenginc.com

13 Jan 2015  
 RV58044-001

### Modulation Characteristics

DNB Job Number:	RV58044-001	Date:	Dec 18 2014	<b>Specification</b> FCC 47 CFR 2.1046 87.131
Customer:	ACSS, an L-3 Communications & Thales Company			
Model Number:	NGT-9000			
Description:	Diversity Mode-S Transponder	S/N:	N/A	
Test Equipment: (See pg. 11)	Asset #'s:2047, 3635, 15387, 1773			
EUT performed within the requirements of the applicable Standard(s) YES <input checked="" type="checkbox"/> NO <input type="checkbox"/> SIGNED Thomas Elders				

### ATCRBS reply single pulse characteristics

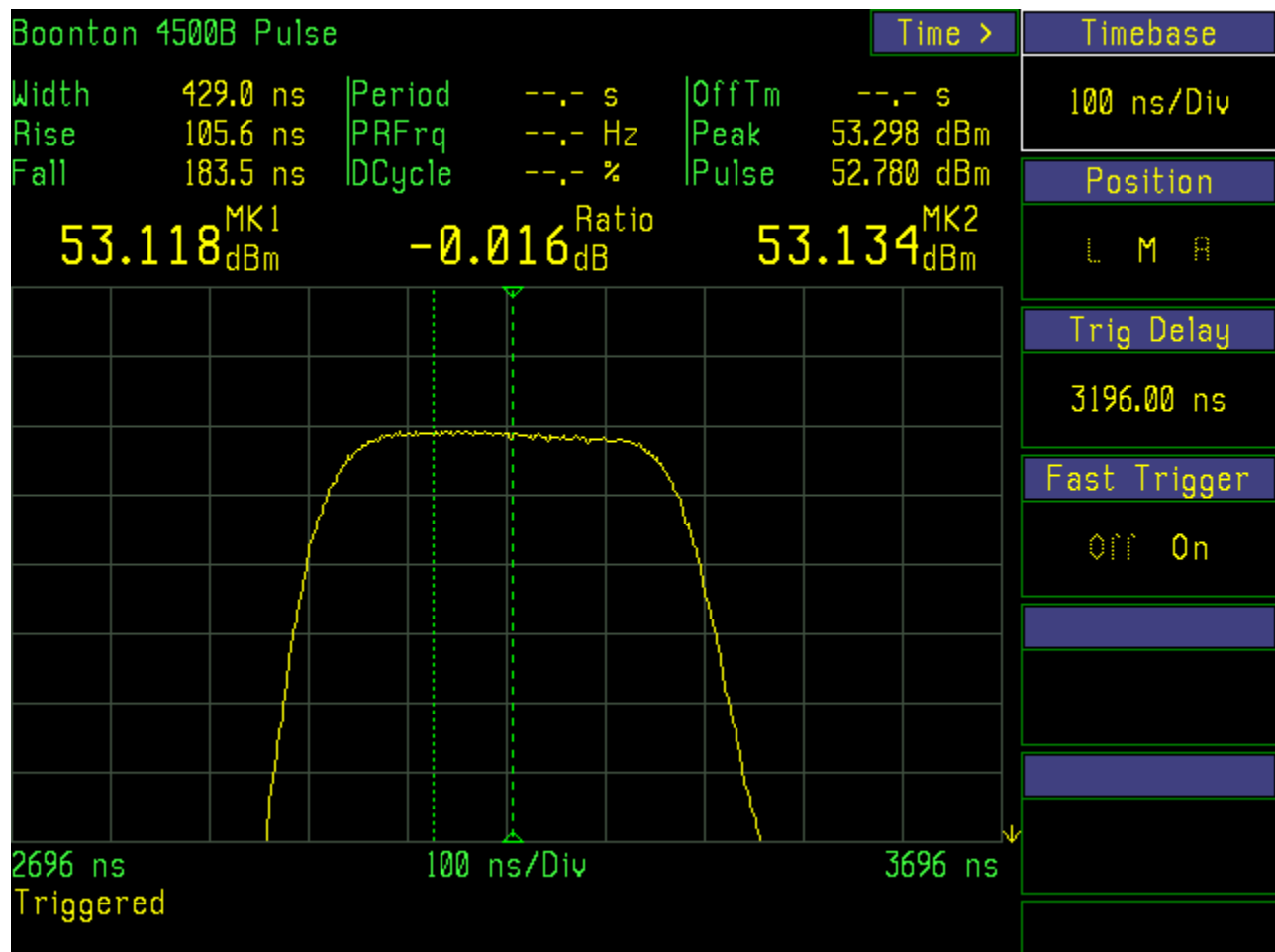



5969 Robinson Ave  
 Riverside, CA 92503  
 (951) 637-2630  
 FAX (951) 637-2704  
 www.dnbenginc.com

13 Jan 2015  
 RV58044-001

### Modulation Characteristics

DNB Job Number:	RV58044-001	Date:	Dec 18 2014	<b>Specification</b> FCC 47 CFR 2.1046 87.131
Customer:	ACSS, an L-3 Communications & Thales Company			
Model Number:	NGT-9000			
Description:	Diversity Mode-S Transponder	S/N:	N/A	
Test Equipment: (See pg. 11)	Asset #'s:2047, 3635, 15387, 1773			
EUT performed within the requirements of the applicable Standard(s) YES <input checked="" type="checkbox"/> NO <input type="checkbox"/> SIGNED Thomas Elders				

### ATCRBS reply

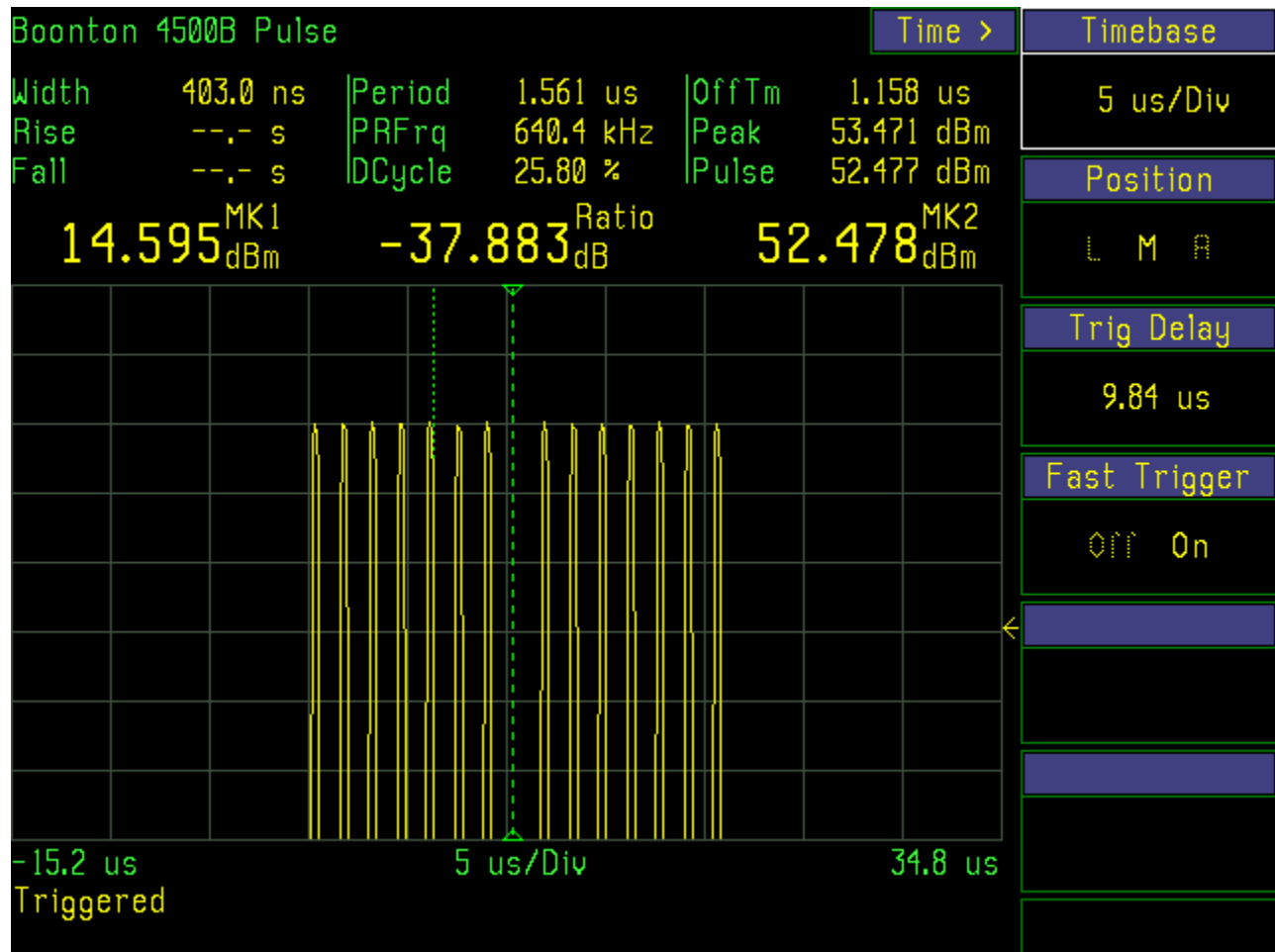



5969 Robinson Ave  
 Riverside, CA 92503  
 (951) 637-2630  
 FAX (951) 637-2704  
 www.dnbenginc.com

13 Jan 2015  
 RV58044-001

### Modulation Characteristics

DNB Job Number:	RV58044-001	Date:	Dec 18 2014	<b>Specification</b> FCC 47 CFR 2.1046 87.131
Customer:	ACSS, an L-3 Communications & Thales Company			
Model Number:	NGT-9000			
Description:	Diversity Mode-S Transponder	S/N:	N/A	
Test Equipment: (See pg. 11)	Asset #'s:2047, 3635, 15387, 1773			
EUT performed within the requirements of the applicable Standard(s) YES <input checked="" type="checkbox"/> NO <input type="checkbox"/> SIGNED Thomas Elders				

### Mode S double PPM

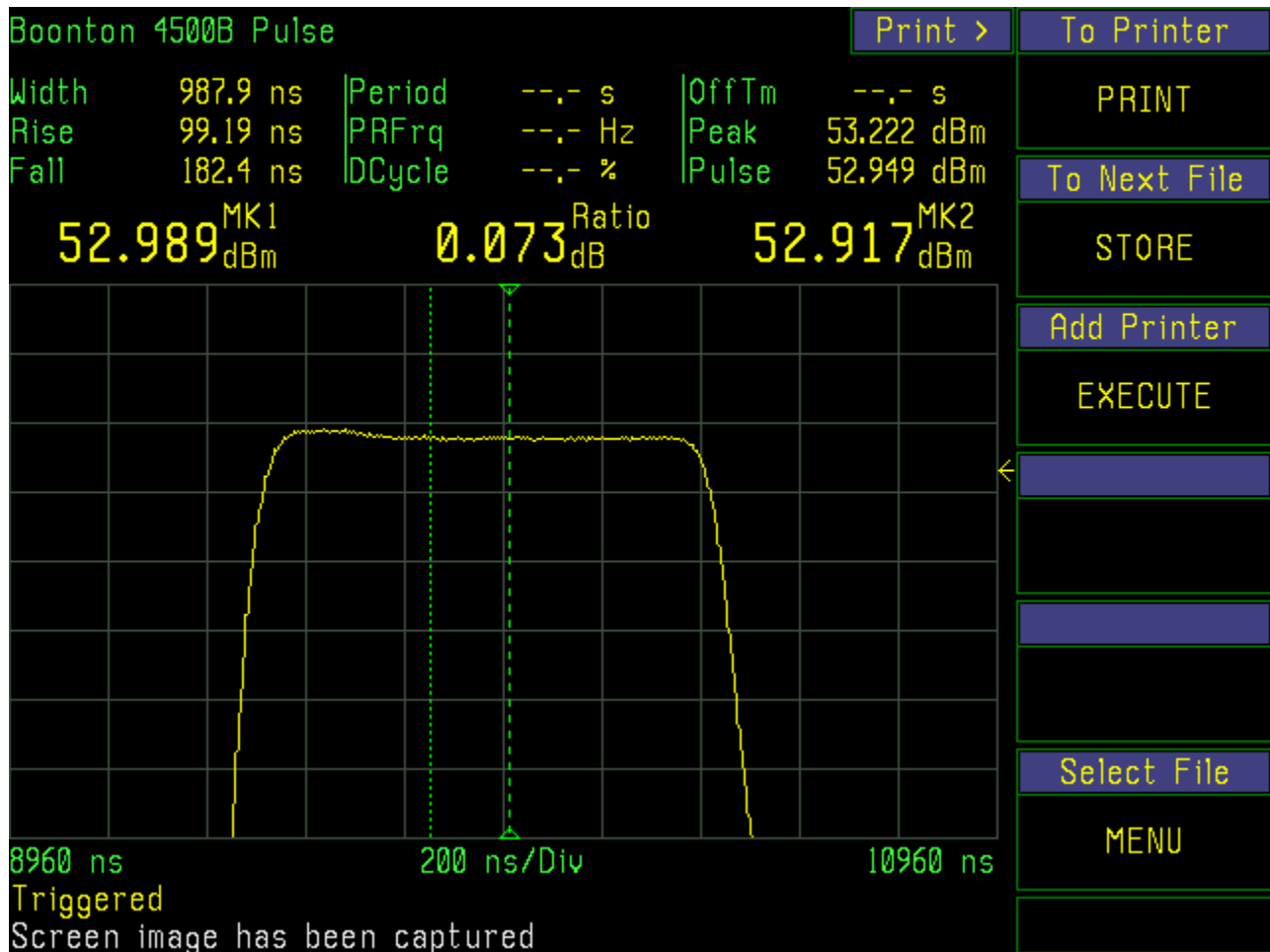



5969 Robinson Ave  
 Riverside, CA 92503  
 (951) 637-2630  
 FAX (951) 637-2704  
 www.dnbenginc.com

13 Jan 2015  
 RV58044-001

### Modulation Characteristics

DNB Job Number:	RV58044-001	Date:	Dec 18 2014	<b>Specification</b> FCC 47 CFR 2.1046 87.131
Customer:	ACSS, an L-3 Communications & Thales Company			
Model Number:	NGT-9000			
Description:	Diversity Mode-S Transponder	S/N:	N/A	
Test Equipment: (See pg. 11)	Asset #'s:2047, 3635, 15387, 1773			
EUT performed within the requirements of the applicable Standard(s) YES <input checked="" type="checkbox"/> NO <input type="checkbox"/> SIGNED Thomas Elders				

### Mode S reply preamble

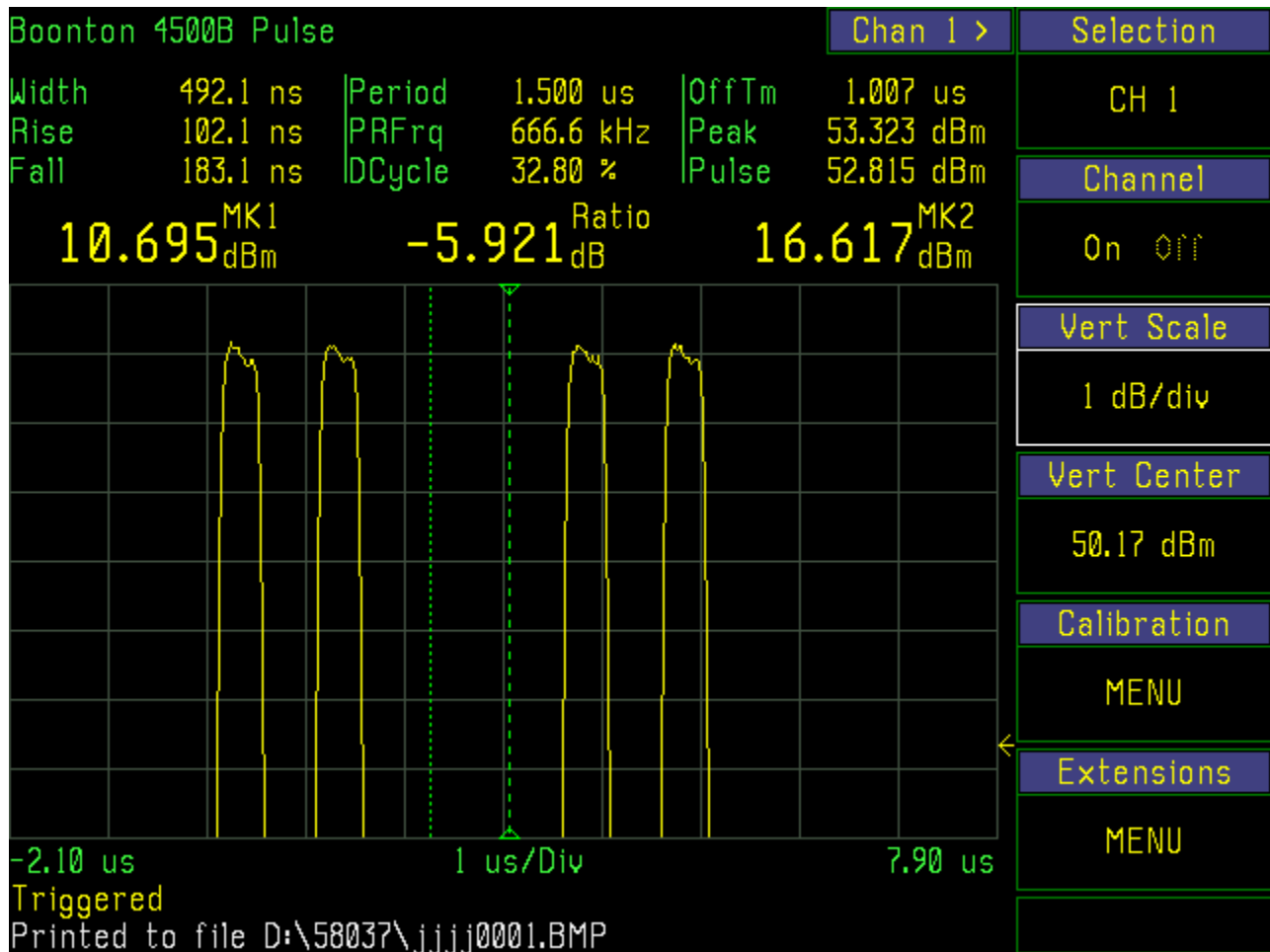



5969 Robinson Ave  
 Riverside, CA 92503  
 (951) 637-2630  
 FAX (951) 637-2704  
 www.dnbenginc.com

13 Jan 2015  
 RV58044-001

### Modulation Characteristics

DNB Job Number:	RV58044-001	Date:	Dec 18 2014	<b>Specification</b> FCC 47 CFR 2.1046 87.131
Customer:	ACSS, an L-3 Communications & Thales Company			
Model Number:	NGT-9000			
Description:	Diversity Mode-S Transponder	S/N:	N/A	
Test Equipment: (See pg. 11)	Asset #'s:2047, 3635, 15387, 1773			
EUT performed within the requirements of the applicable Standard(s) YES <input checked="" type="checkbox"/> NO <input type="checkbox"/> SIGNED Thomas Elders				

#### Mode S reply single pulse characteristics

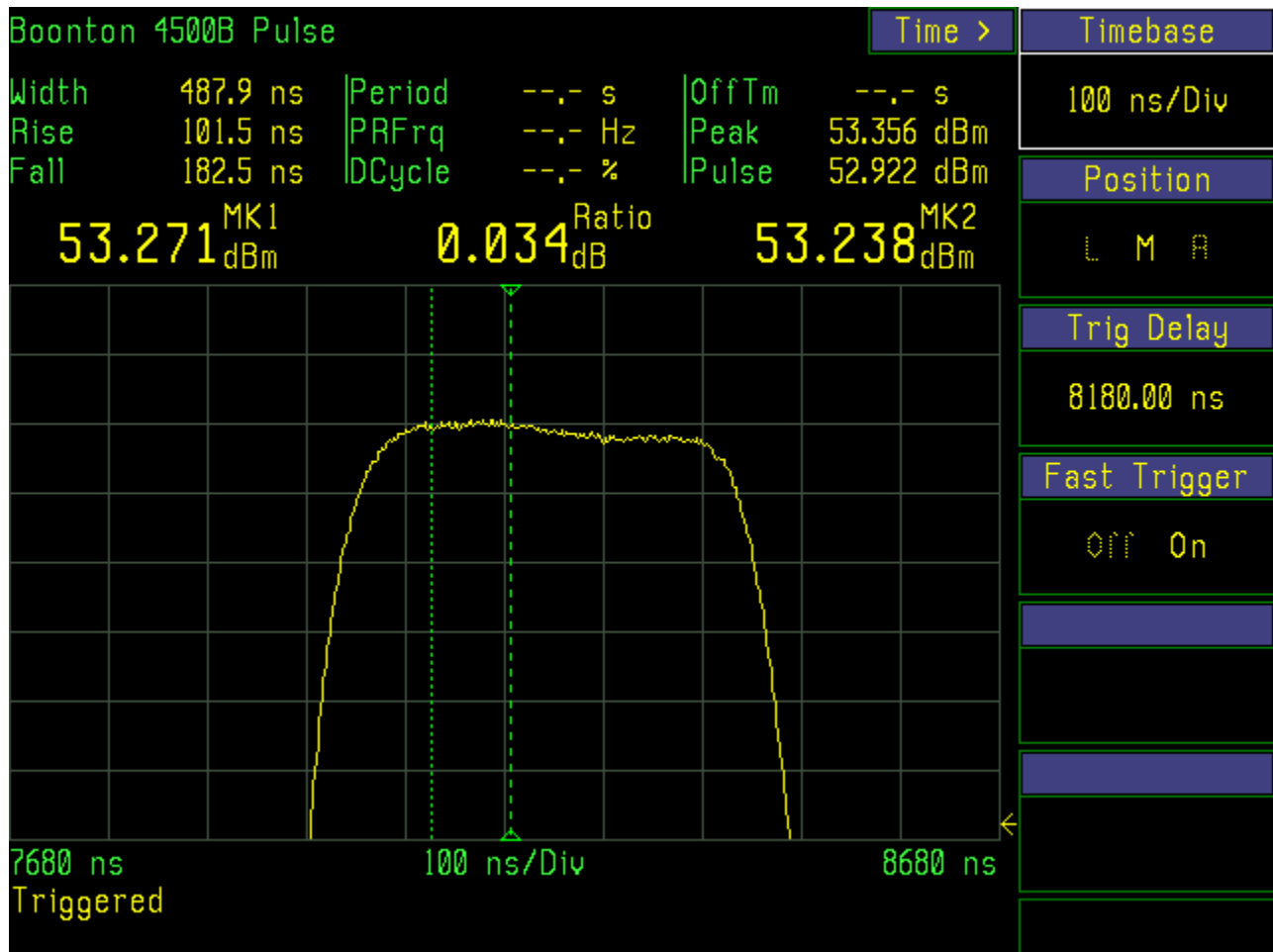



5969 Robinson Ave  
 Riverside, CA 92503  
 (951) 637-2630  
 FAX (951) 637-2704  
 www.dnbenginc.com

13 Jan 2015  
 RV58044-001

### Modulation Characteristics

DNB Job Number:	RV58044-001	Date:	Dec 18 2014	<b>Specification</b> FCC 47 CFR 2.1046 87.131
Customer:	ACSS, an L-3 Communications & Thales Company			
Model Number:	NGT-9000			
Description:	Diversity Mode-S Transponder	S/N:	N/A	
Test Equipment: (See pg. 11)	Asset #'s:2047, 3635, 15387, 1773			
EUT performed within the requirements of the applicable Standard(s) YES <input checked="" type="checkbox"/> NO <input type="checkbox"/> SIGNED Thomas Elders				

### Mode S single PPM

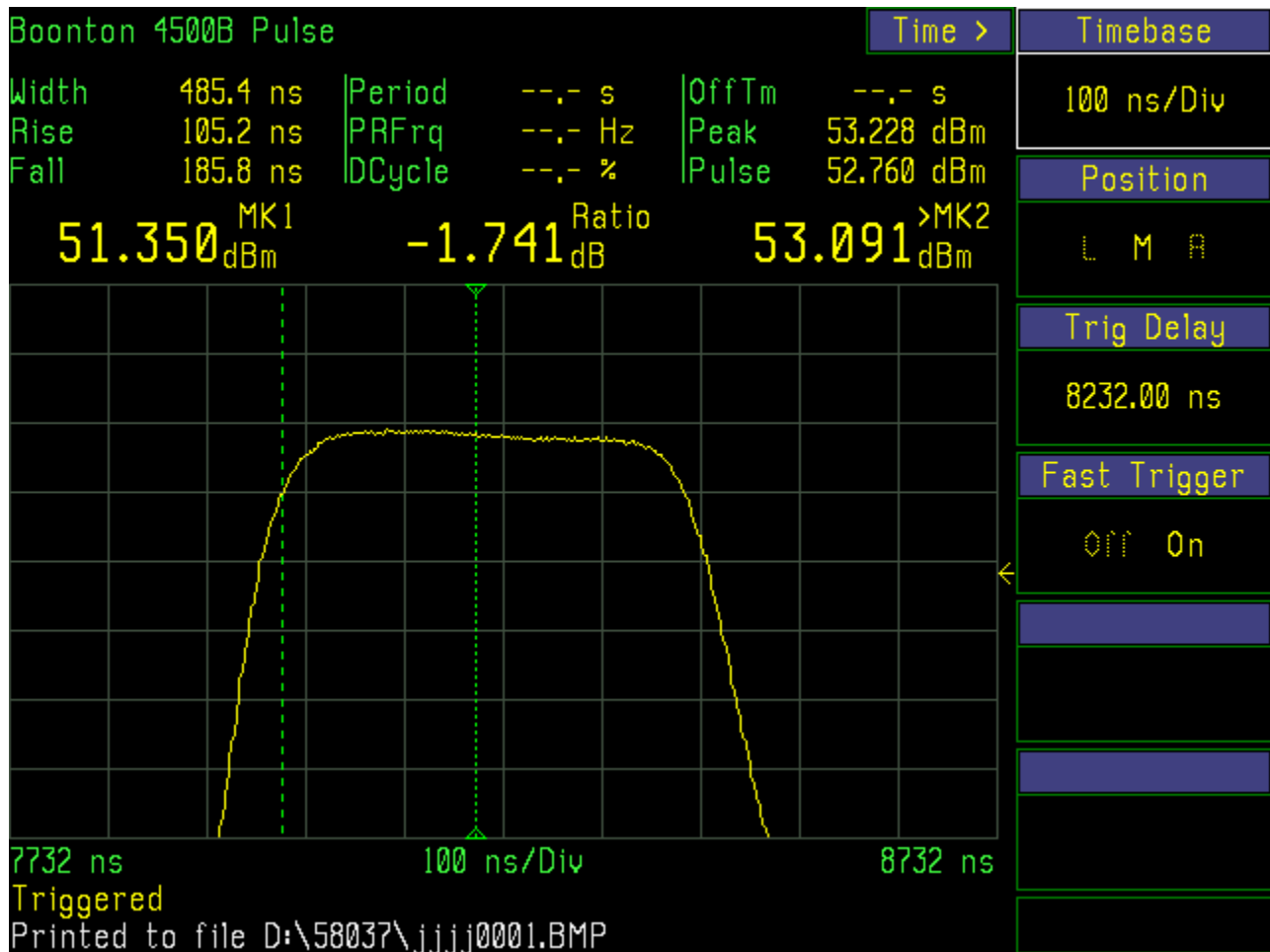



5969 Robinson Ave  
 Riverside, CA 92503  
 (951) 637-2630  
 FAX (951) 637-2704  
 www.dnbenginc.com

13 Jan 2015  
 RV58044-001

### Occupied Bandwidth

DNB Job Number:	RV58044-001	Date:	Dec 17 2014	<b>Specification</b> FCC 47 CFR 2.1051 87.139
Customer:	ACSS, an L-3 Communications & Thales Company			
Model Number:	NGT-9000			
Description:	Diversity Mode-S Transponder	S/N:	N/A	
Test Equipment: (See pg. 11)	Asset #'s:2047, 3635, 2264			
EUT performed within the requirements of the applicable Standard(s) YES <input checked="" type="checkbox"/> NO <input type="checkbox"/> SIGNED Thomas Elders				

### Occupied Bandwidth 20dBc TAS ATRBS top port: 10.625MHz

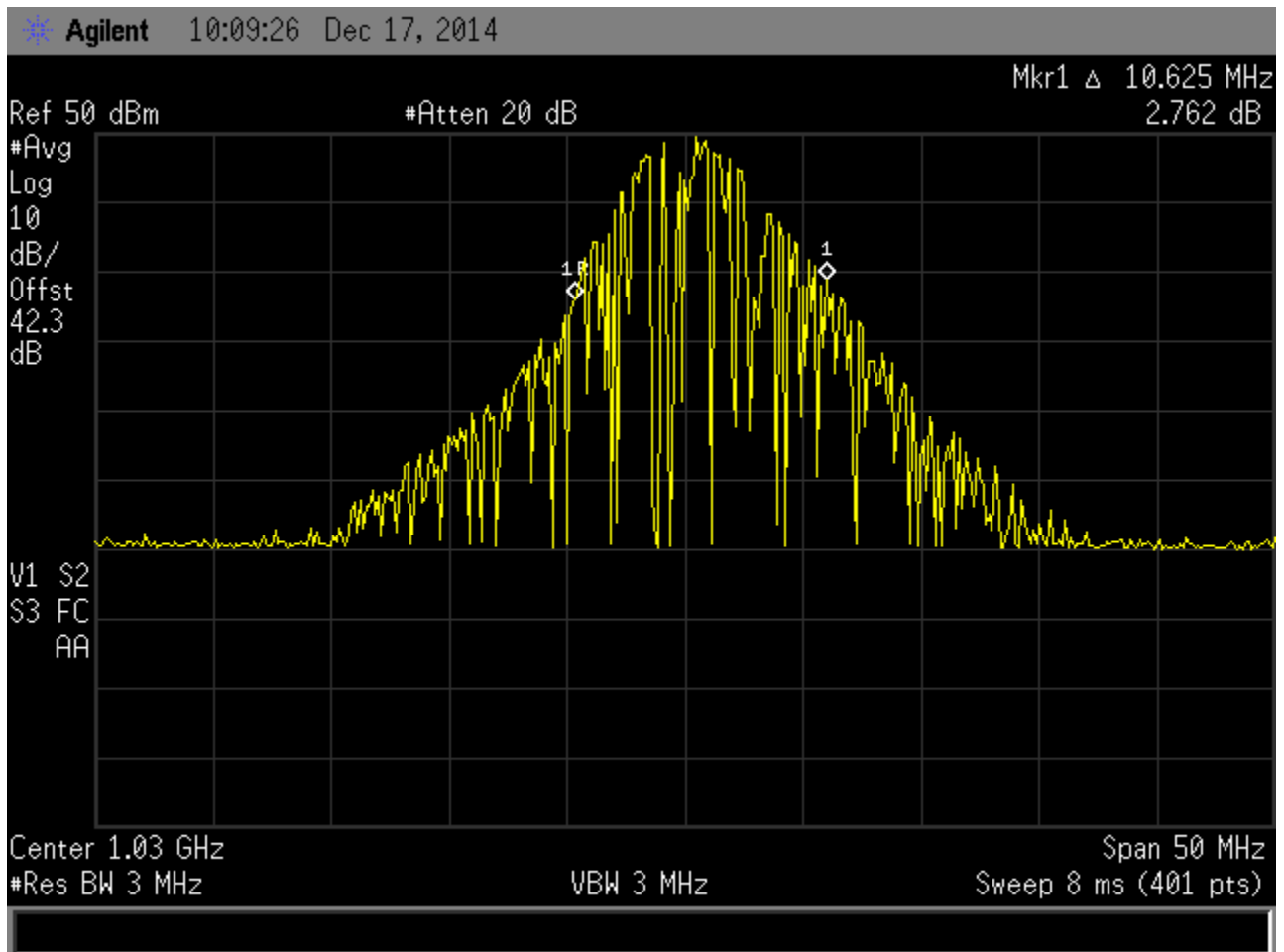



5969 Robinson Ave  
 Riverside, CA 92503  
 (951) 637-2630  
 FAX (951) 637-2704  
 www.dnbenginc.com

13 Jan 2015  
 RV58044-001

### Occupied Bandwidth

DNB Job Number:	RV58044-001	Date:	Dec 17 2014	<b>Specification</b> FCC 47 CFR 2.1051 87.139
Customer:	ACSS, an L-3 Communications & Thales Company			
Model Number:	NGT-9000			
Description:	Diversity Mode-S Transponder	S/N:	N/A	
Test Equipment: (See pg. 11)	Asset #'s:2047, 3635, 2264			
EUT performed within the requirements of the applicable Standard(s) YES <input checked="" type="checkbox"/> NO <input type="checkbox"/> SIGNED Thomas Elders				

### Occupied Bandwidth 20dBc XPDR ATCRBS bottom port: 12.65MHz

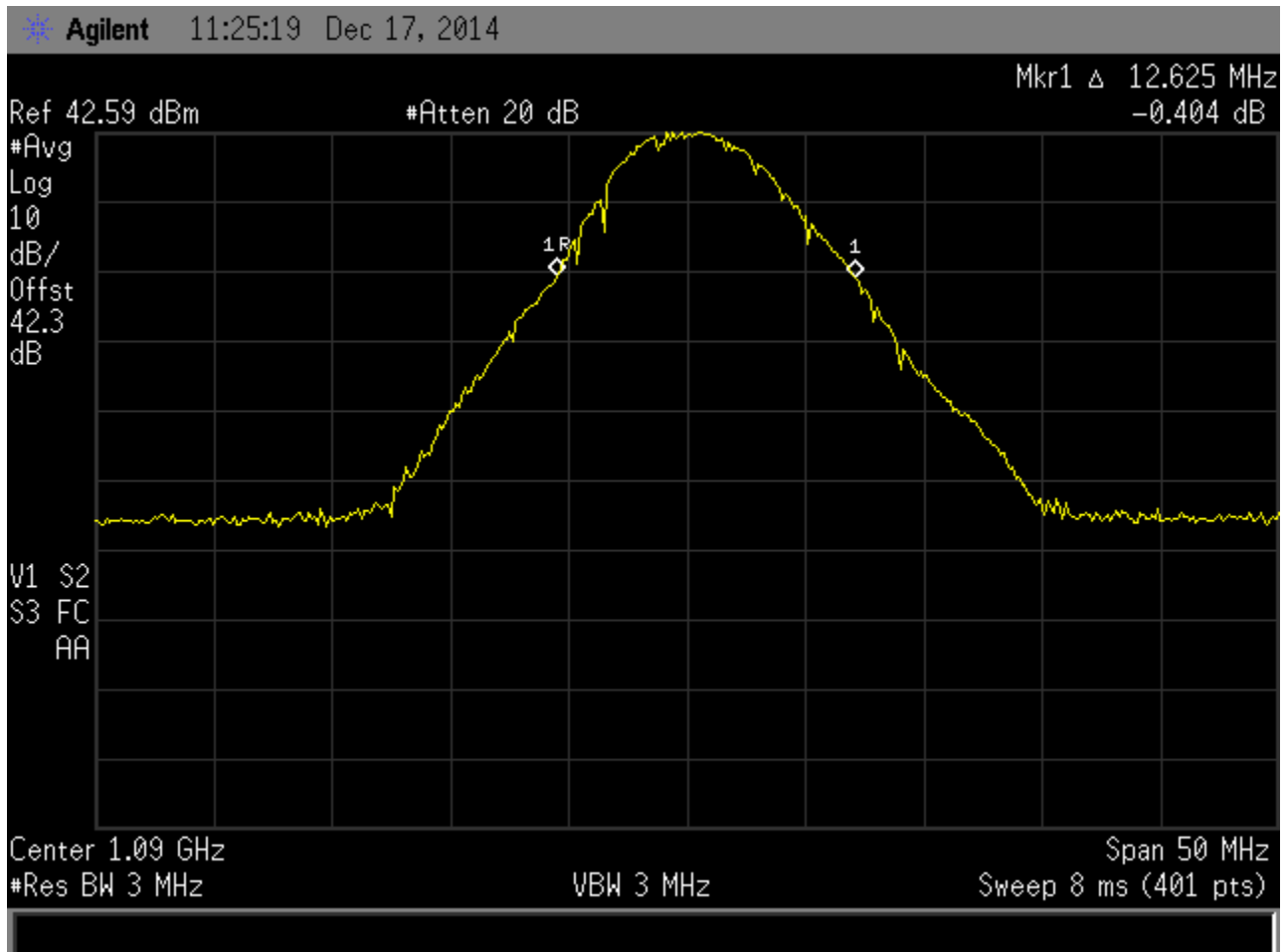





5969 Robinson Ave  
 Riverside, CA 92503  
 (951) 637-2630  
 FAX (951) 637-2704  
 www.dnbenginc.com

13 Jan 2015  
 RV58044-001

### Occupied Bandwidth

DNB Job Number:	RV58044-001	Date:	Dec 17 2014	<b>Specification</b> FCC 47 CFR 2.1051 87.139
Customer:	ACSS, an L-3 Communications & Thales Company			
Model Number:	NGT-9000			
Description:	Diversity Mode-S Transponder	S/N:	N/A	
Test Equipment: (See pg. 11)	Asset #'s:2047, 3635, 2264			
EUT performed within the requirements of the applicable Standard(s) YES <input checked="" type="checkbox"/> NO <input type="checkbox"/> SIGNED Thomas Elders				

### Occupied Bandwidth 20dBc XPDR ATCRBS top port: 10.625MHz

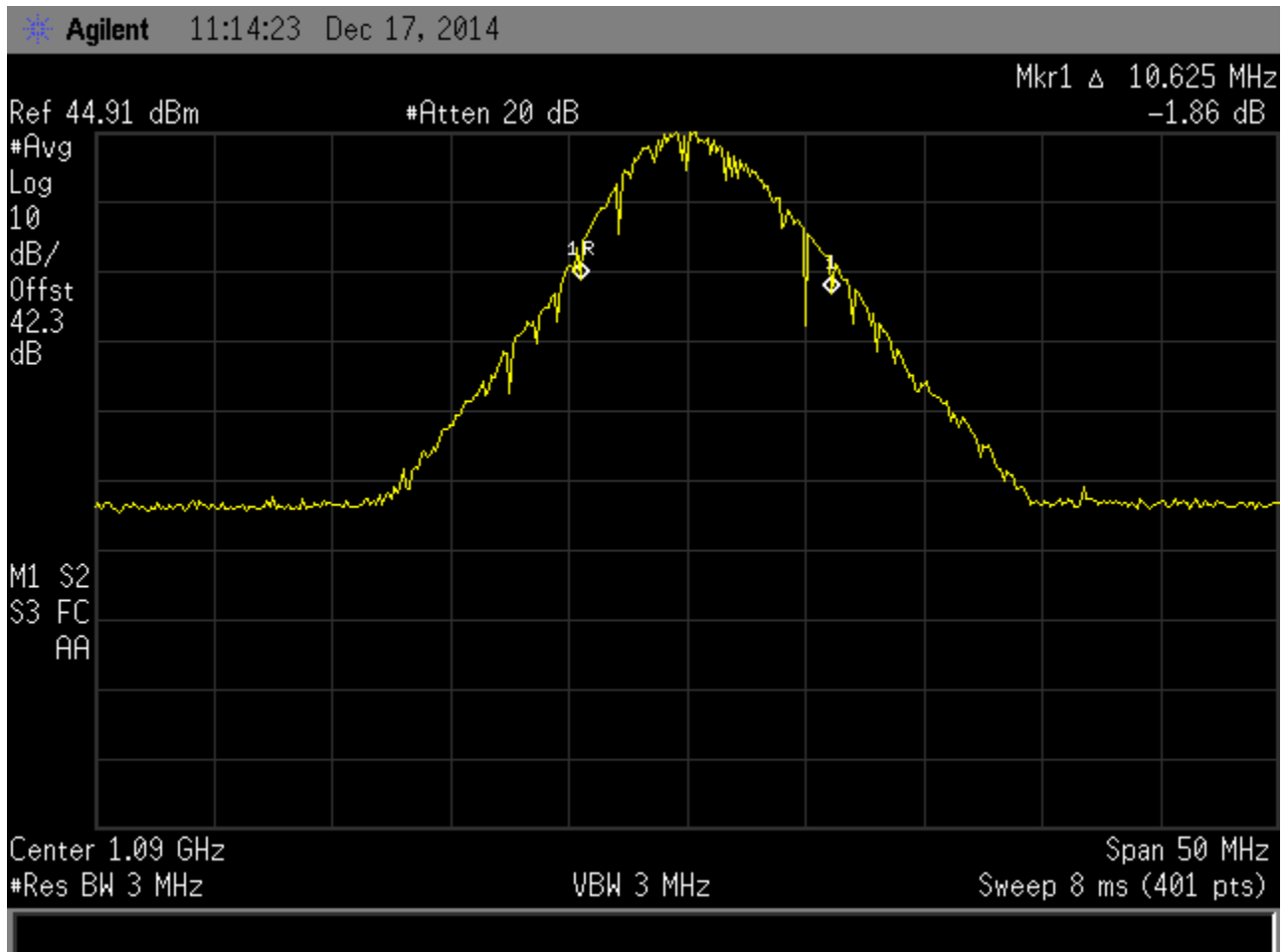



5969 Robinson Ave  
 Riverside, CA 92503  
 (951) 637-2630  
 FAX (951) 637-2704  
 www.dnbenginc.com

13 Jan 2015  
 RV58044-001

### Occupied Bandwidth

DNB Job Number:	RV58044-001	Date:	Dec 17 2014	<b>Specification</b> FCC 47 CFR 2.1051 87.139
Customer:	ACSS, an L-3 Communications & Thales Company			
Model Number:	NGT-9000			
Description:	Diversity Mode-S Transponder	S/N:	N/A	
Test Equipment: (See pg. 11)	Asset #'s:2047, 3635, 2264			
EUT performed within the requirements of the applicable Standard(s) YES <input checked="" type="checkbox"/> NO <input type="checkbox"/> SIGNED Thomas Elders				

### Occupied Bandwidth 20dBc XPDR Mode S bottom port: 10.65MHz

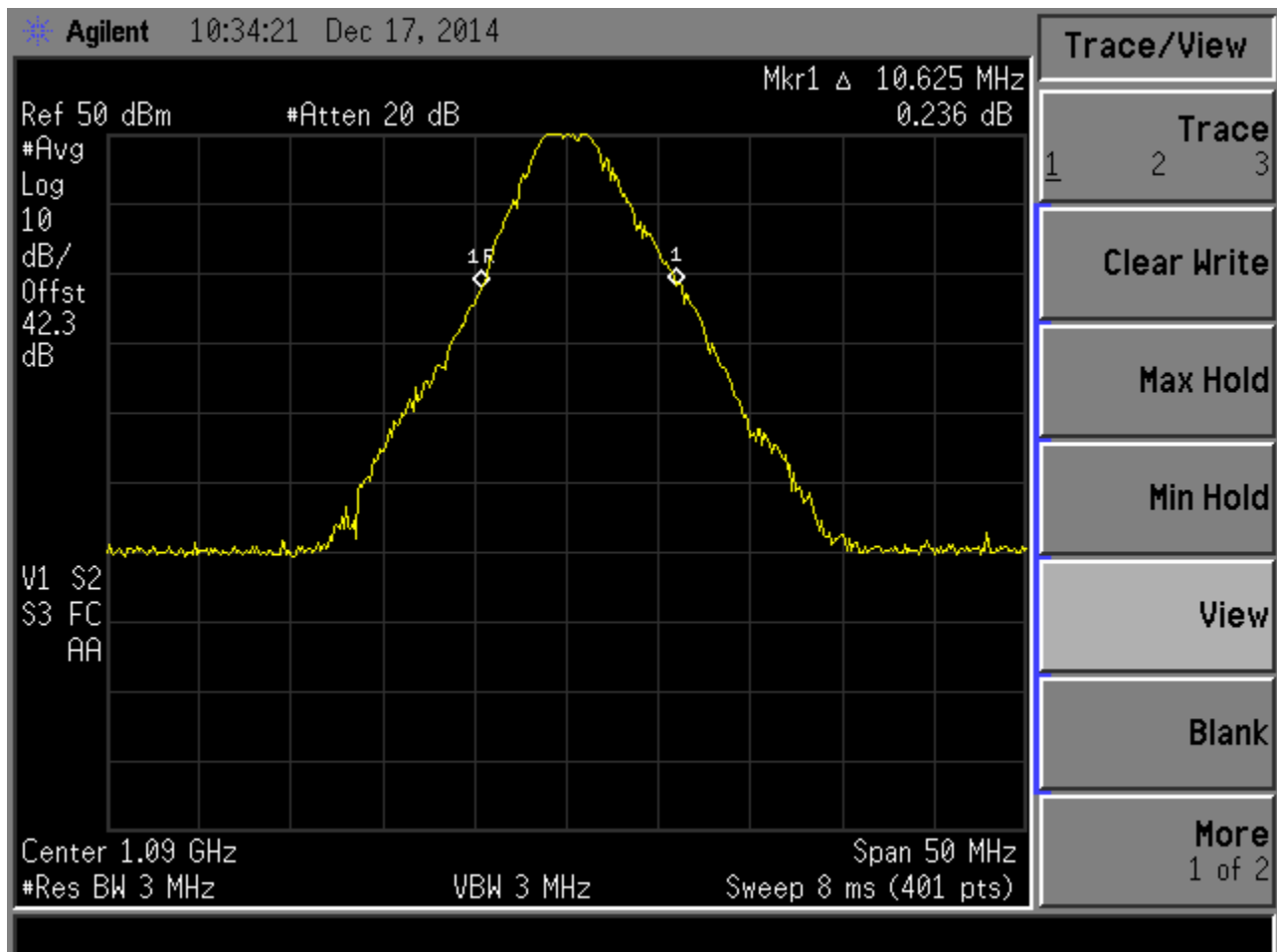



5969 Robinson Ave  
 Riverside, CA 92503  
 (951) 637-2630  
 FAX (951) 637-2704  
 www.dnbenginc.com

13 Jan 2015  
 RV58044-001

### Occupied Bandwidth

DNB Job Number:	RV58044-001	Date:	Dec 17 2014	<b>Specification</b> FCC 47 CFR 2.1051 87.139
Customer:	ACSS, an L-3 Communications & Thales Company			
Model Number:	NGT-9000			
Description:	Diversity Mode-S Transponder	S/N:	N/A	
Test Equipment: (See pg. 11)	Asset #'s:2047, 3635, 2264			
EUT performed within the requirements of the applicable Standard(s) YES <input checked="" type="checkbox"/> NO <input type="checkbox"/> SIGNED Thomas Elders				

### Occupied Bandwidth 20dBc XPDR Mode S top port: 10.625MHz

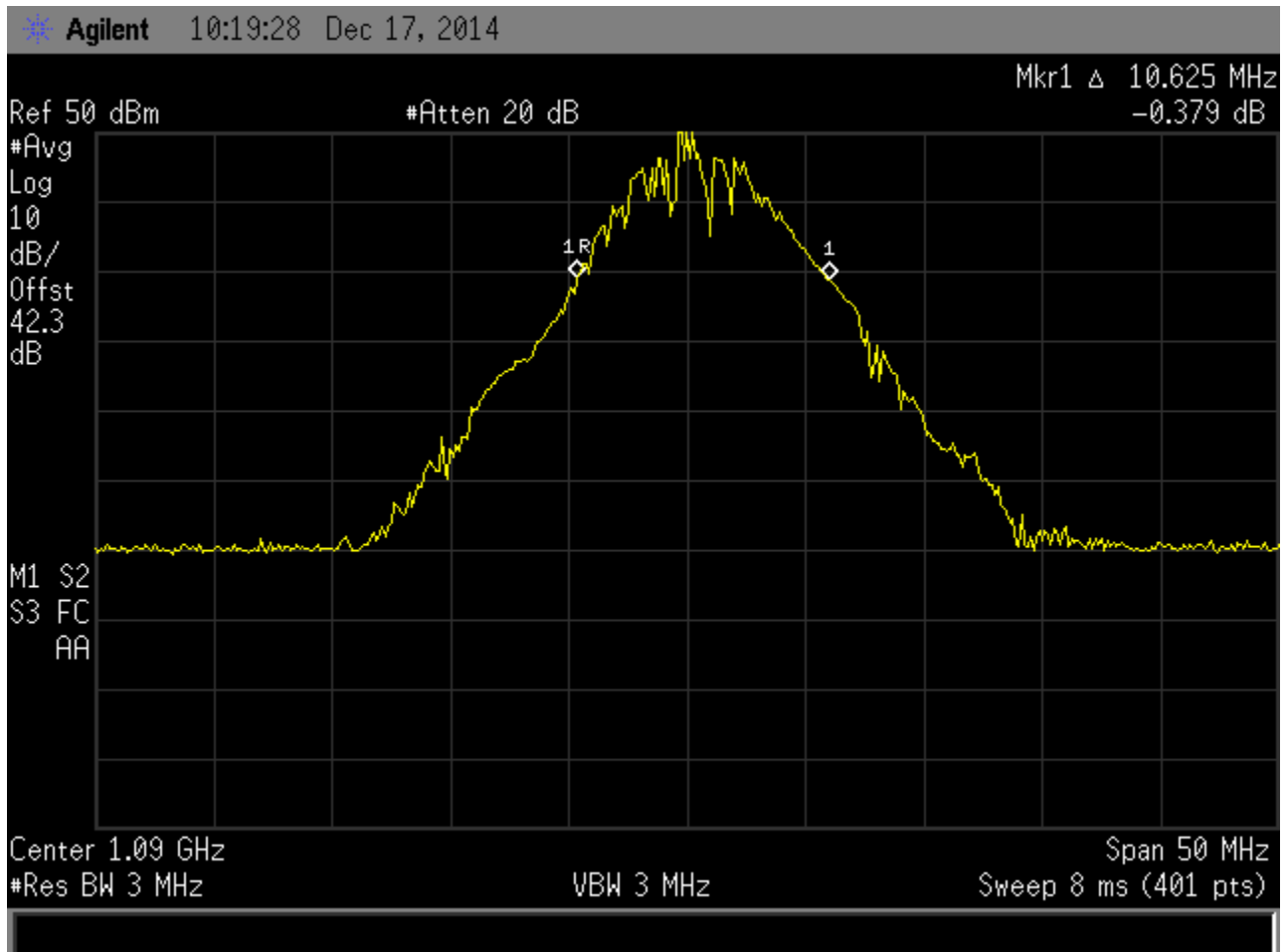



5969 Robinson Ave  
Riverside, CA 92503  
(951) 637-2630  
FAX (951) 637-2704  
www.dnbenginc.com

13 Jan 2015  
RV58044-001

### Spurious Emissions at antenna terminals

DNB Job Number:	RV58044-001	Date:	Dec 17 2014	<b>Specification</b> FCC 47 CFR 2.1051 87.139
Customer:	ACSS, an L-3 Communications & Thales Company			
Model Number:	NGT-9000			
Description:	Diversity Mode-S Transponder	S/N:	N/A	
Test Equipment: (See pg. 11)	Asset #'s: 2047, 3066, 3635, 2264			
EUT performed within the requirements of the applicable Standard(s) YES <input checked="" type="checkbox"/> NO <input type="checkbox"/> SIGNED Thomas Elders				

### TAS conducted spurious 30MHz – 2GHz

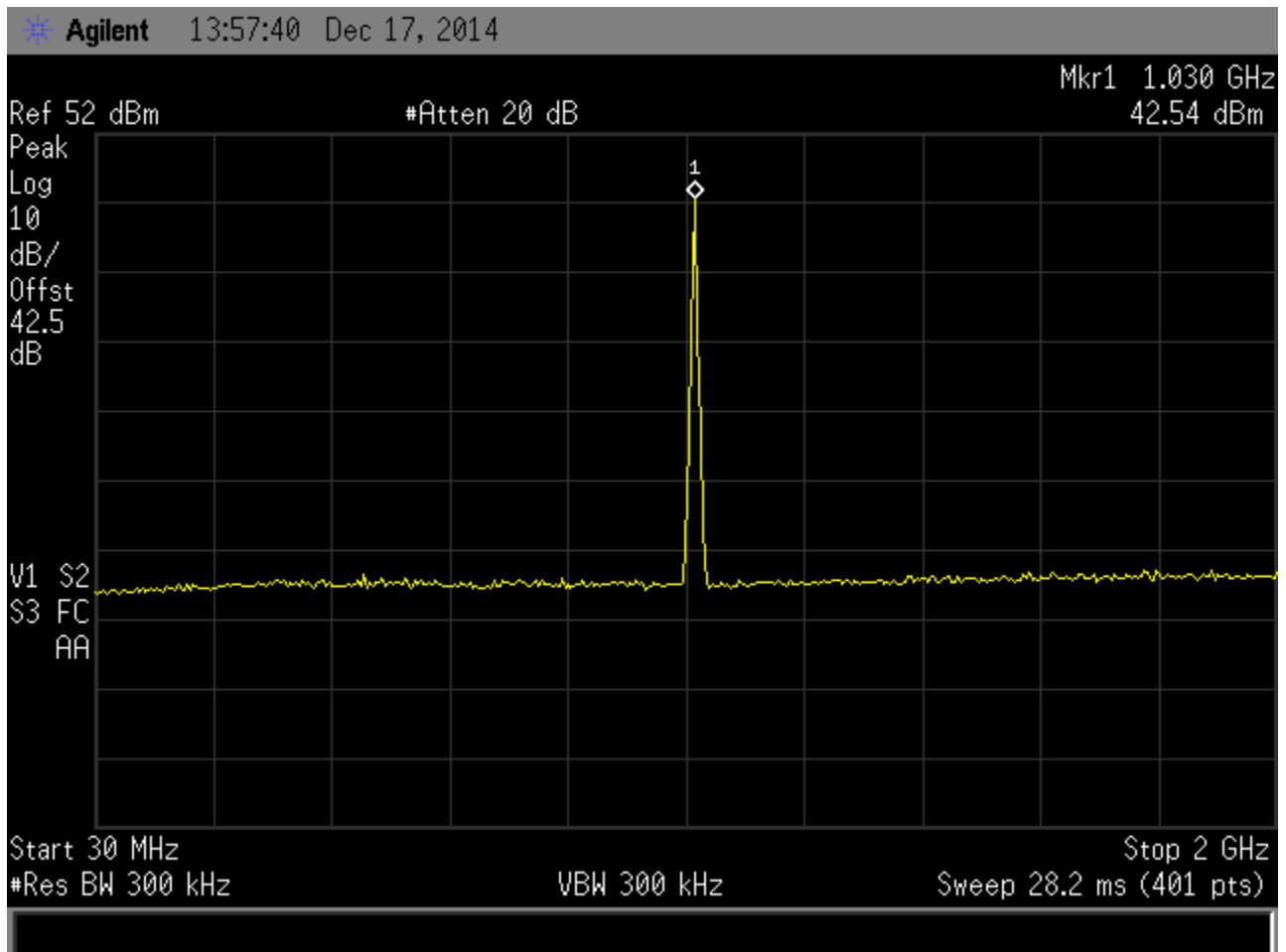



5969 Robinson Ave  
Riverside, CA 92503  
(951) 637-2630  
FAX (951) 637-2704  
www.dnbenginc.com

13 Jan 2015  
RV58044-001

### Spurious Emissions at antenna terminals

DNB Job Number:	RV58044-001	Date:	Dec 17 2014	<b>Specification</b> FCC 47 CFR 2.1051 87.139
Customer:	ACSS, an L-3 Communications & Thales Company			
Model Number:	NGT-9000			
Description:	Diversity Mode-S Transponder	S/N:	N/A	
Test Equipment: (See pg. 11)	Asset #'s: 2047, 3066, 3635, 2264			
EUT performed within the requirements of the applicable Standard(s) YES <input checked="" type="checkbox"/> NO <input type="checkbox"/> SIGNED Thomas Elders				

### TAS Conducted Spurious 2060MHz

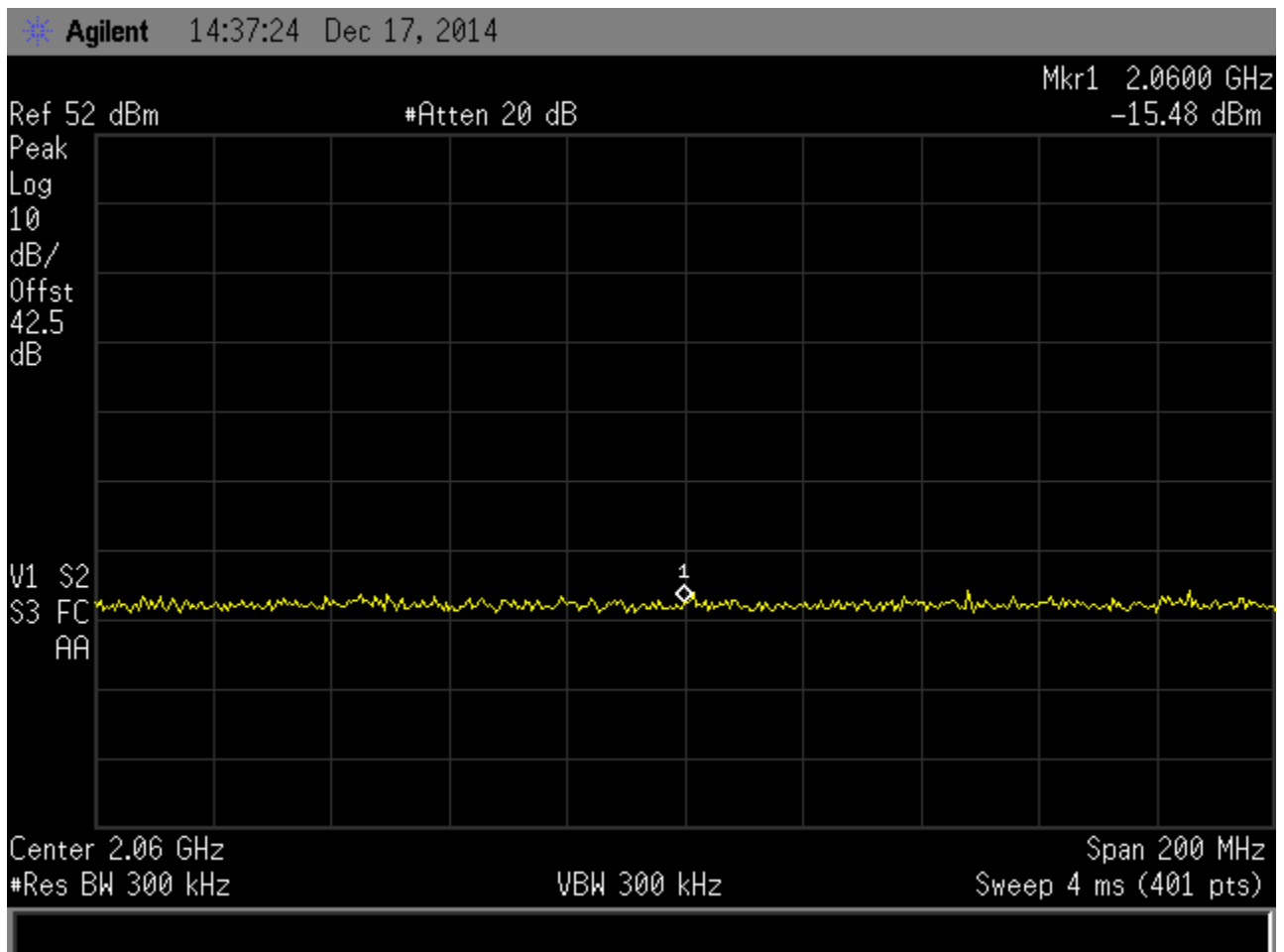



5969 Robinson Ave  
Riverside, CA 92503  
(951) 637-2630  
FAX (951) 637-2704  
www.dnbenginc.com

13 Jan 2015  
RV58044-001

### Spurious Emissions at antenna terminals

DNB Job Number:	RV58044-001	Date:	Dec 17 2014	<b>Specification</b> FCC 47 CFR 2.1051 87.139
Customer:	ACSS, an L-3 Communications & Thales Company			
Model Number:	NGT-9000			
Description:	Diversity Mode-S Transponder	S/N:	N/A	
Test Equipment: (See pg. 11)	Asset #'s: 2047, 3066, 3635, 2264			
EUT performed within the requirements of the applicable Standard(s) YES <input checked="" type="checkbox"/> NO <input type="checkbox"/> SIGNED Thomas Elders				

### TAS Conducted Spurious 3090MHz

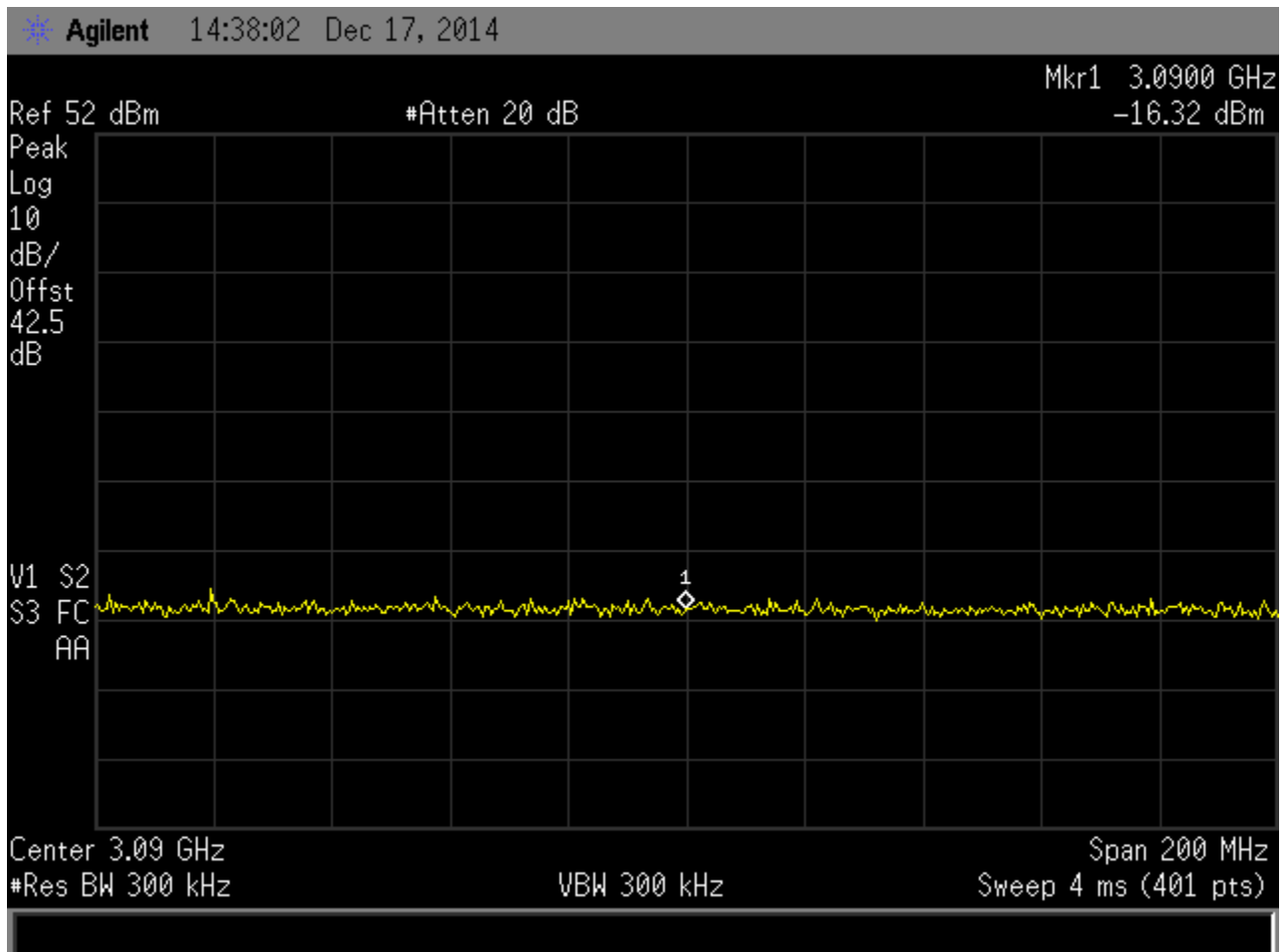



5969 Robinson Ave  
Riverside, CA 92503  
(951) 637-2630  
FAX (951) 637-2704  
www.dnbenginc.com

13 Jan 2015  
RV58044-001

### Spurious Emissions at antenna terminals

DNB Job Number:	RV58044-001	Date:	Dec 17 2014	<b>Specification</b> FCC 47 CFR 2.1051 87.139
Customer:	ACSS, an L-3 Communications & Thales Company			
Model Number:	NGT-9000			
Description:	Diversity Mode-S Transponder	S/N:	N/A	
Test Equipment: (See pg. 11)	Asset #'s: 2047, 3066, 3635, 2264			
EUT performed within the requirements of the applicable Standard(s) YES <input checked="" type="checkbox"/> NO <input type="checkbox"/> SIGNED Thomas Elders				

### TAS Conducted Spurious 4120MHz

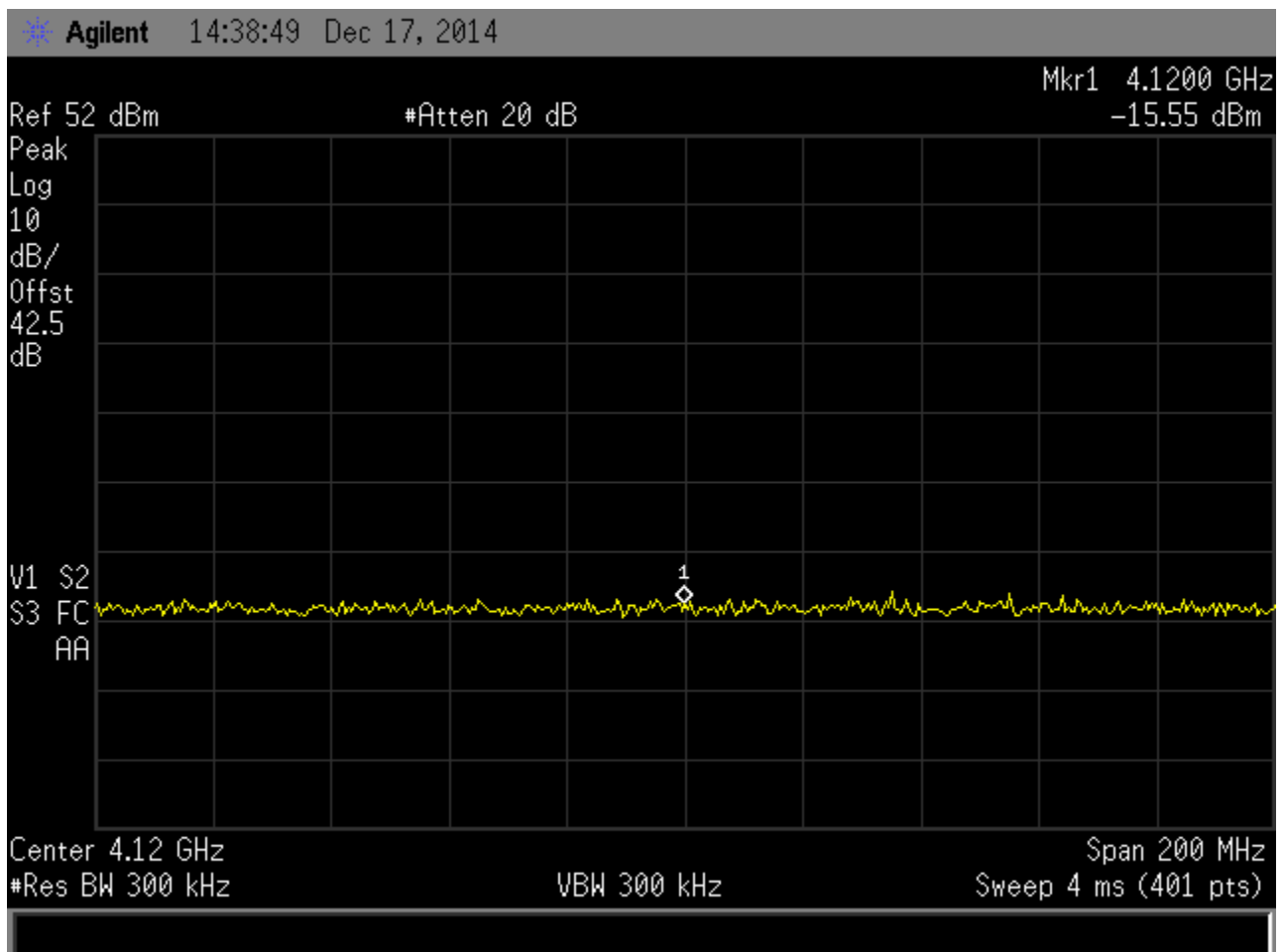



5969 Robinson Ave  
Riverside, CA 92503  
(951) 637-2630  
FAX (951) 637-2704  
www.dnbenginc.com

13 Jan 2015  
RV58044-001

### Spurious Emissions at antenna terminals

DNB Job Number:	RV58044-001	Date:	Dec 17 2014	<b>Specification</b> FCC 47 CFR 2.1051 87.139
Customer:	ACSS, an L-3 Communications & Thales Company			
Model Number:	NGT-9000			
Description:	Diversity Mode-S Transponder	S/N:	N/A	
Test Equipment: (See pg. 11)	Asset #'s: 2047, 3066, 3635, 2264			
EUT performed within the requirements of the applicable Standard(s) YES <input checked="" type="checkbox"/> NO <input type="checkbox"/> SIGNED Thomas Elders				

### TAS Conducted Spurious 5150MHz

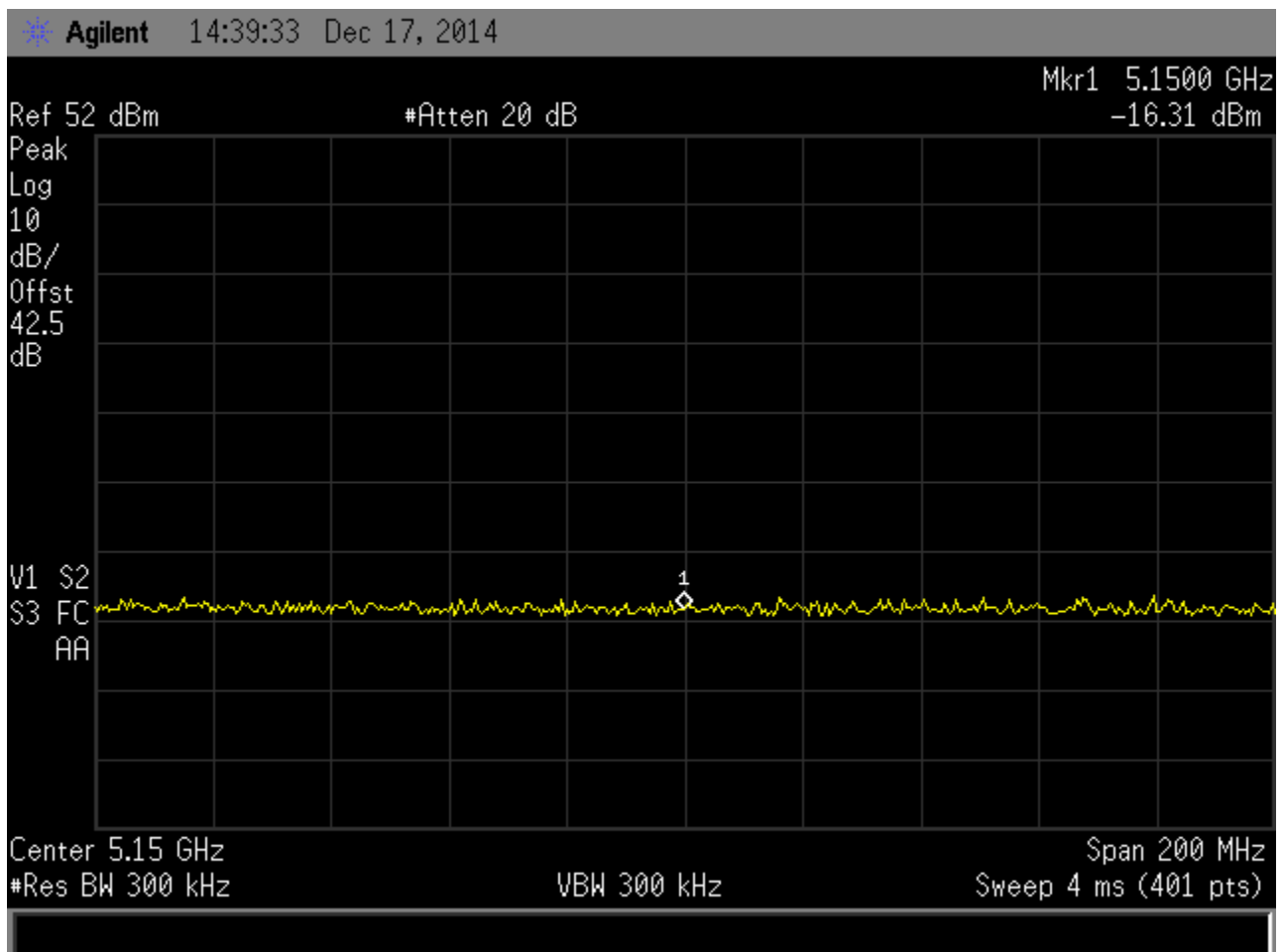





5969 Robinson Ave  
 Riverside, CA 92503  
 (951) 637-2630  
 FAX (951) 637-2704  
 www.dnbenginc.com

13 Jan 2015  
 RV58044-001

### Spurious Emissions at antenna terminals

DNB Job Number:	RV58044-001	Date:	Dec 17 2014	<b>Specification</b> FCC 47 CFR 2.1051 87.139
Customer:	ACSS, an L-3 Communications & Thales Company			
Model Number:	NGT-9000			
Description:	Diversity Mode-S Transponder	S/N:	N/A	
Test Equipment: (See pg. 11)	Asset #'s: 2047, 3066, 3635, 2264			
EUT performed within the requirements of the applicable Standard(s) YES <input checked="" type="checkbox"/> NO <input type="checkbox"/> SIGNED Thomas Elders				

### TAS Conducted Spurious 6180MHz

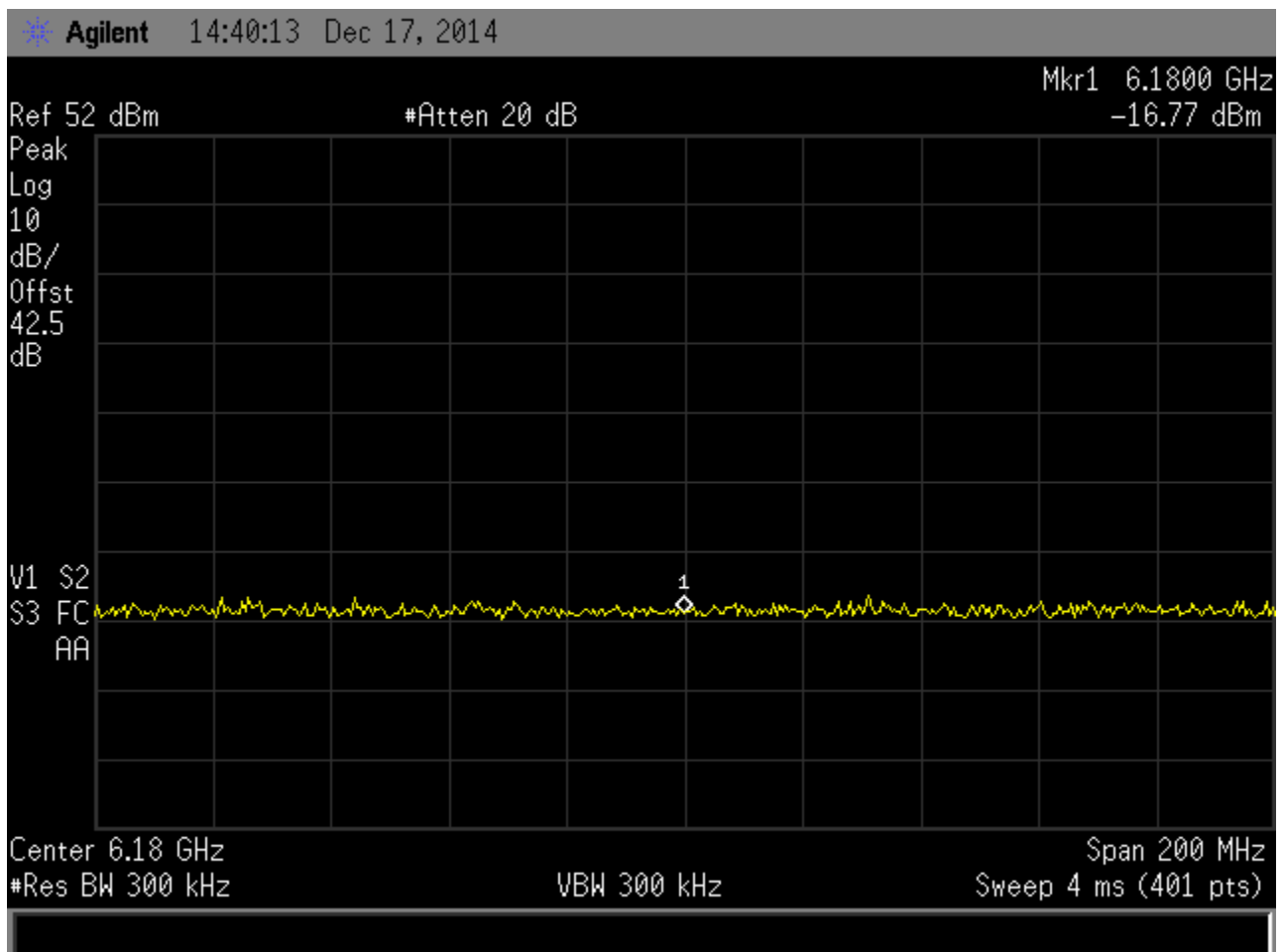



5969 Robinson Ave  
 Riverside, CA 92503  
 (951) 637-2630  
 FAX (951) 637-2704  
 www.dnbenginc.com

13 Jan 2015  
 RV58044-001

### Spurious Emissions at antenna terminals

DNB Job Number:	RV58044-001	Date:	Dec 17 2014	<b>Specification</b> FCC 47 CFR 2.1051 87.139
Customer:	ACSS, an L-3 Communications & Thales Company			
Model Number:	NGT-9000			
Description:	Diversity Mode-S Transponder	S/N:	N/A	
Test Equipment: (See pg. 11)	Asset #'s: 2047, 3066, 3635, 2264			
EUT performed within the requirements of the applicable Standard(s) YES <input checked="" type="checkbox"/> NO <input type="checkbox"/> SIGNED Thomas Elders				

### TAS Conducted Spurious 7210MHz

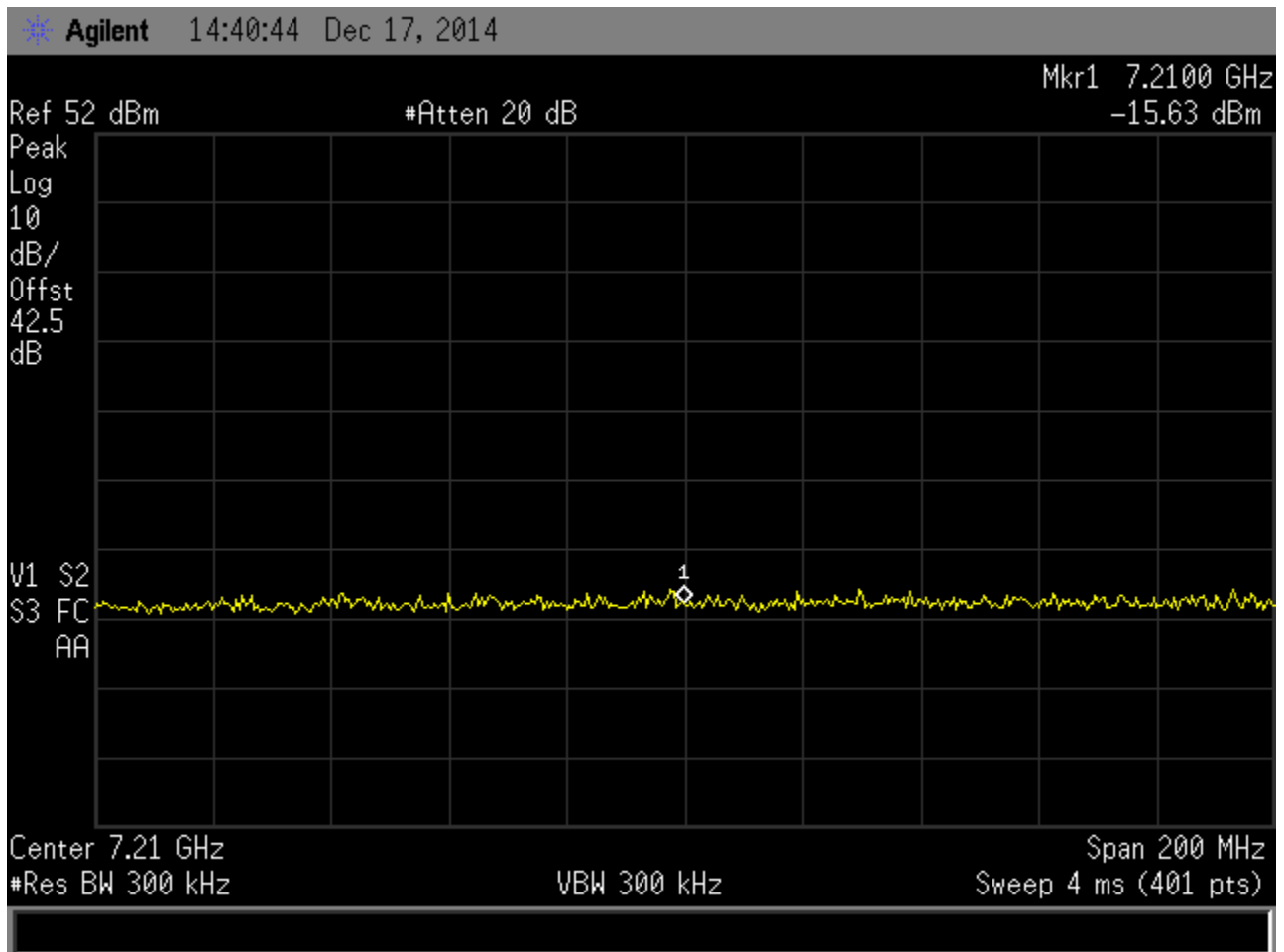



5969 Robinson Ave  
Riverside, CA 92503  
(951) 637-2630  
FAX (951) 637-2704  
www.dnbenginc.com

13 Jan 2015  
RV58044-001

### Spurious Emissions at antenna terminals

DNB Job Number:	RV58044-001	Date:	Dec 17 2014	<b>Specification</b> FCC 47 CFR 2.1051 87.139
Customer:	ACSS, an L-3 Communications & Thales Company			
Model Number:	NGT-9000			
Description:	Diversity Mode-S Transponder	S/N:	N/A	
Test Equipment: (See pg. 11)	Asset #'s: 2047, 3066, 3635, 2264			
EUT performed within the requirements of the applicable Standard(s) YES <input checked="" type="checkbox"/> NO <input type="checkbox"/> SIGNED Thomas Elders				

### TAS Conducted Spurious 8240MHz

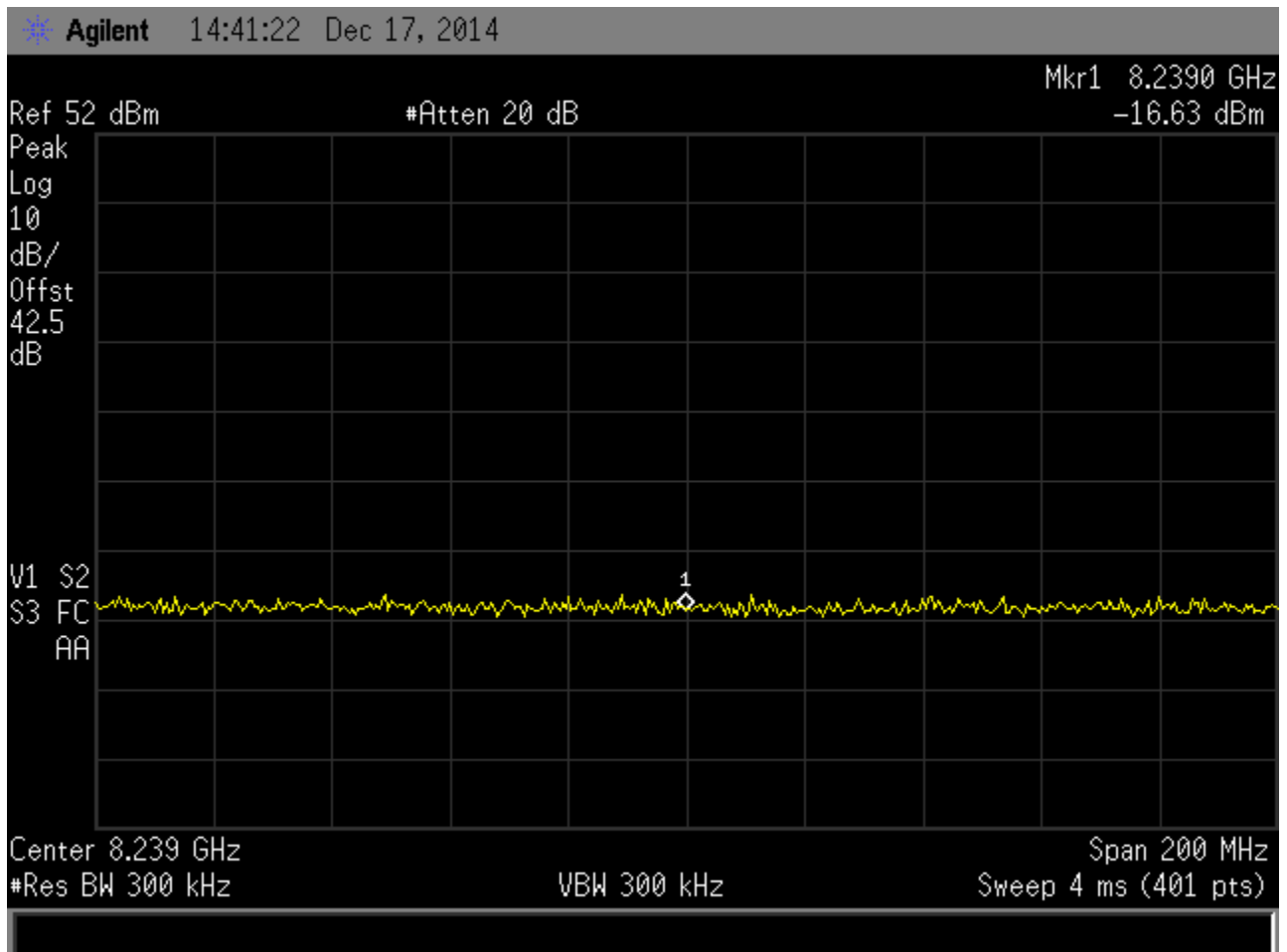



5969 Robinson Ave  
Riverside, CA 92503  
(951) 637-2630  
FAX (951) 637-2704  
www.dnbenginc.com

13 Jan 2015  
RV58044-001

### Spurious Emissions at antenna terminals

DNB Job Number:	RV58044-001	Date:	Dec 17 2014	<b>Specification</b> FCC 47 CFR 2.1051 87.139
Customer:	ACSS, an L-3 Communications & Thales Company			
Model Number:	NGT-9000			
Description:	Diversity Mode-S Transponder	S/N:	N/A	
Test Equipment: (See pg. 11)	Asset #'s: 2047, 3066, 3635, 2264			
EUT performed within the requirements of the applicable Standard(s) YES <input checked="" type="checkbox"/> NO <input type="checkbox"/> SIGNED Thomas Elders				

### TAS Conducted Spurious 9270MHz

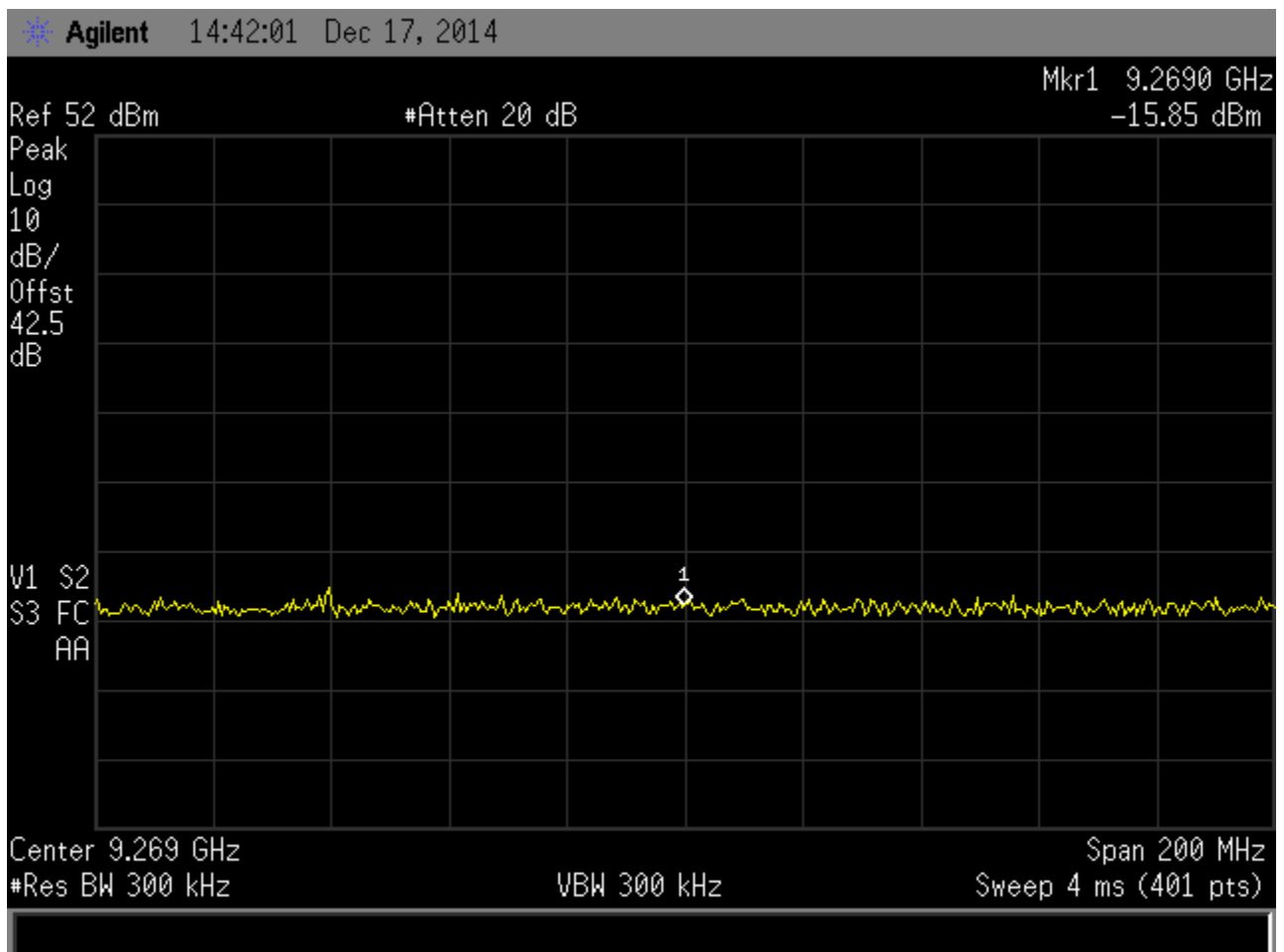



5969 Robinson Ave  
Riverside, CA 92503  
(951) 637-2630  
FAX (951) 637-2704  
www.dnbenginc.com

13 Jan 2015  
RV58044-001

### Spurious Emissions at antenna terminals

DNB Job Number:	RV58044-001	Date:	Dec 17 2014	<b>Specification</b> FCC 47 CFR 2.1051 87.139
Customer:	ACSS, an L-3 Communications & Thales Company			
Model Number:	NGT-9000			
Description:	Diversity Mode-S Transponder	S/N:	N/A	
Test Equipment: (See pg. 11)	Asset #'s: 2047, 3066, 3635, 2264			
EUT performed within the requirements of the applicable Standard(s) YES <input checked="" type="checkbox"/> NO <input type="checkbox"/> SIGNED Thomas Elders				

### TAS Conducted Spurious 10300MHz

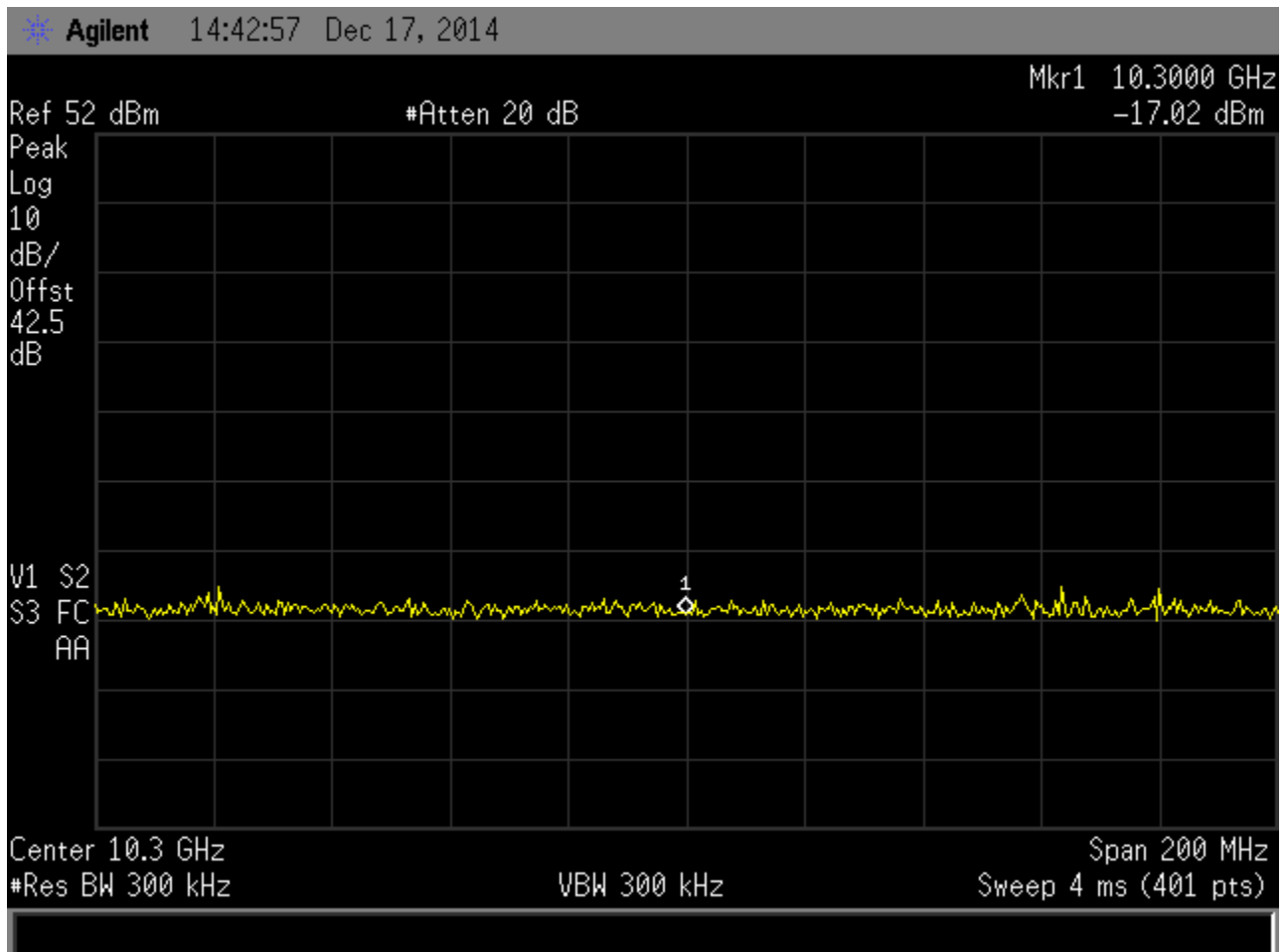



5969 Robinson Ave  
Riverside, CA 92503  
(951) 637-2630  
FAX (951) 637-2704  
www.dnbenginc.com

13 Jan 2015  
RV58044-001

### Spurious Emissions at antenna terminals

DNB Job Number:	RV58044-001	Date:	Dec 17 2014	<b>Specification</b> FCC 47 CFR 2.1051 87.139
Customer:	ACSS, an L-3 Communications & Thales Company			
Model Number:	NGT-9000			
Description:	Diversity Mode-S Transponder	S/N:	N/A	
Test Equipment: (See pg. 11)	Asset #'s: 2047, 3066, 3635, 2264			
EUT performed within the requirements of the applicable Standard(s) YES <input checked="" type="checkbox"/> NO <input type="checkbox"/> SIGNED Thomas Elders				

### XPDR Conducted Spurious top port 30MHz – 2GHz

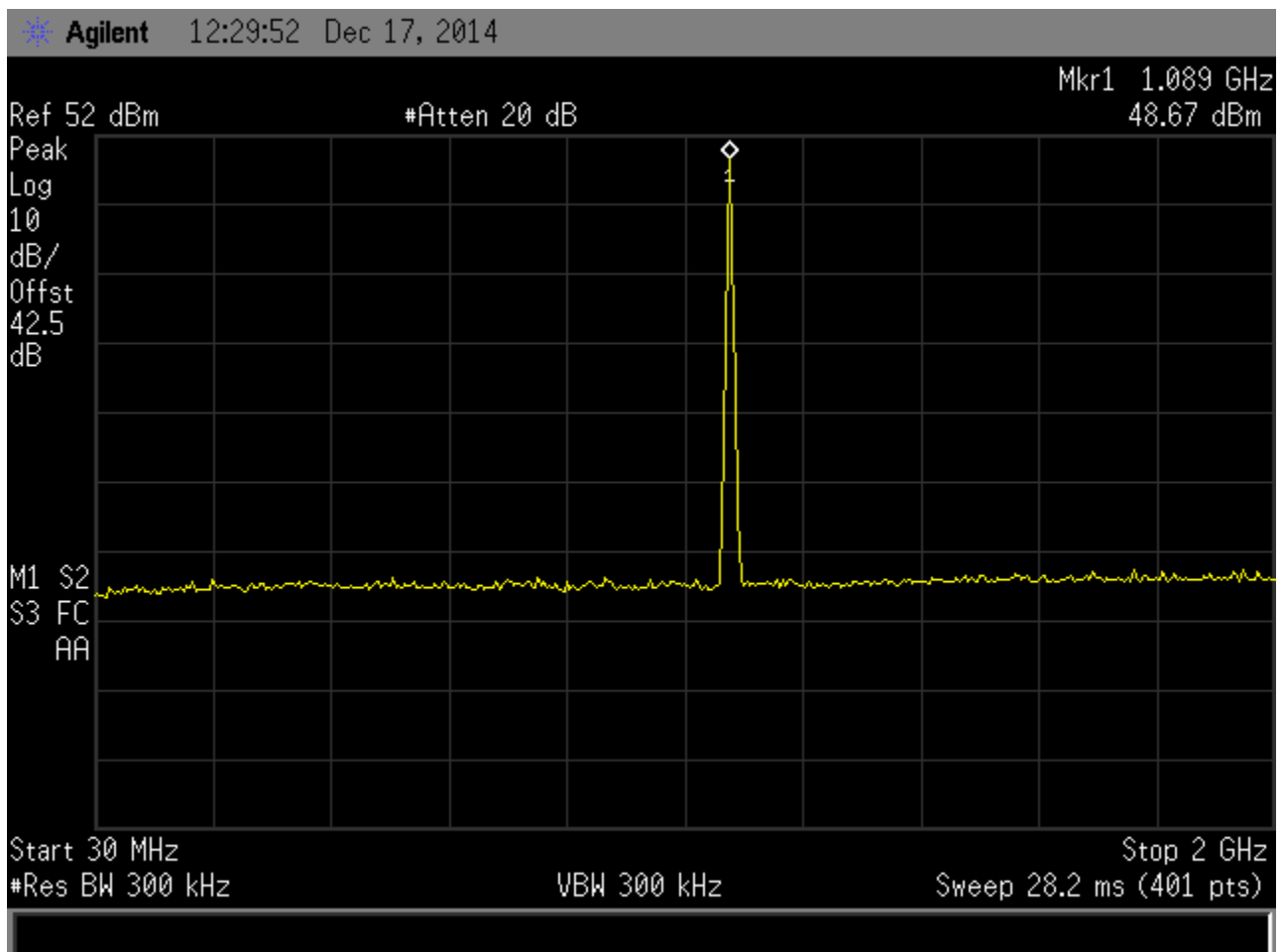



5969 Robinson Ave  
 Riverside, CA 92503  
 (951) 637-2630  
 FAX (951) 637-2704  
 www.dnbenginc.com

13 Jan 2015  
 RV58044-001

### Spurious Emissions at antenna terminals

DNB Job Number:	RV58044-001	Date:	Dec 17 2014	<b>Specification</b> FCC 47 CFR 2.1051 87.139
Customer:	ACSS, an L-3 Communications & Thales Company			
Model Number:	NGT-9000			
Description:	Diversity Mode-S Transponder	S/N:	N/A	
Test Equipment: (See pg. 11)	Asset #'s: 2047, 3066, 3635, 2264			
EUT performed within the requirements of the applicable Standard(s) YES <input checked="" type="checkbox"/> NO <input type="checkbox"/> SIGNED Thomas Elders				

### XPDR Conducted Spurious top port 2180MHz

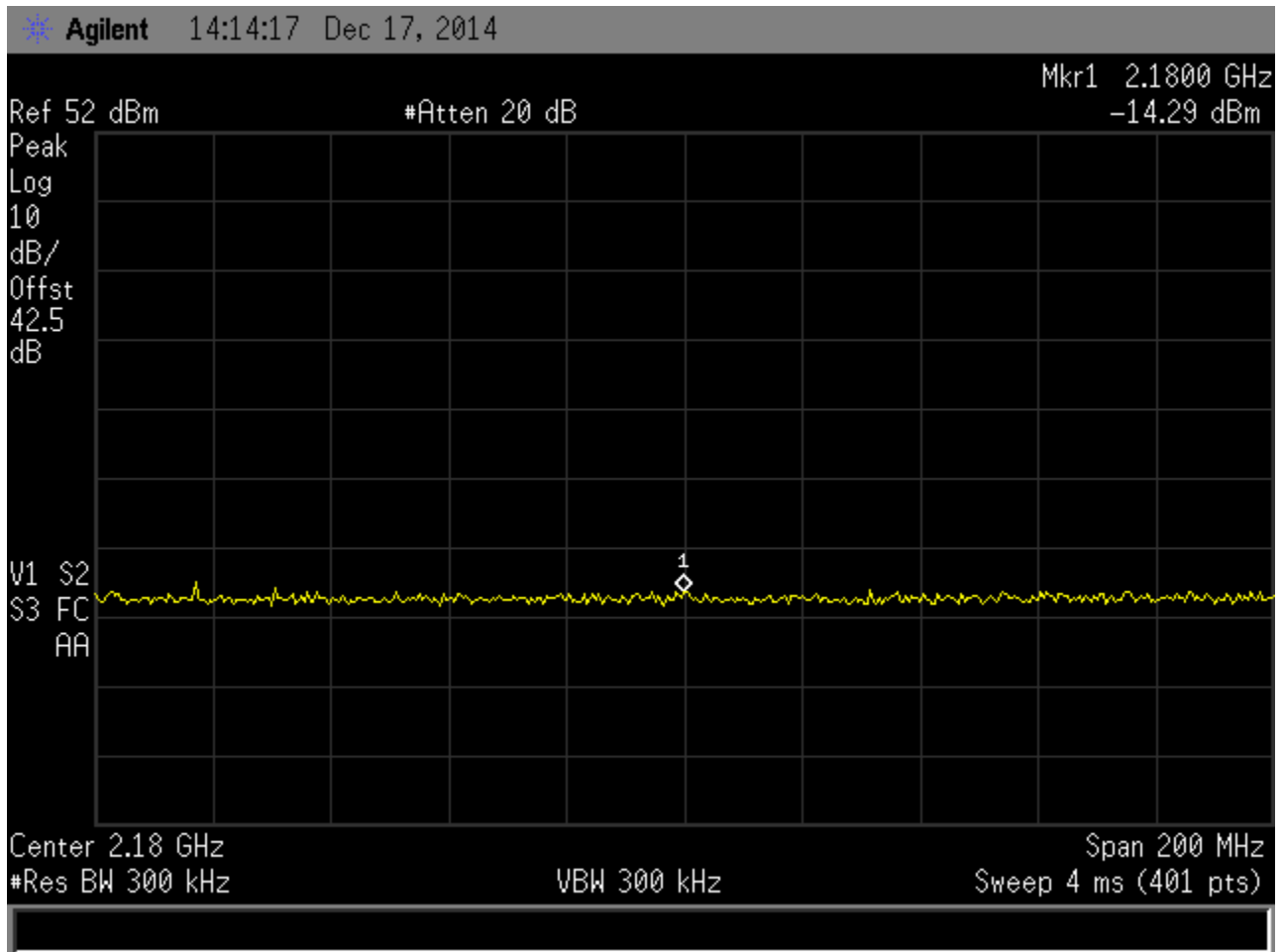



5969 Robinson Ave  
 Riverside, CA 92503  
 (951) 637-2630  
 FAX (951) 637-2704  
 www.dnbenginc.com

13 Jan 2015  
 RV58044-001

### Spurious Emissions at antenna terminals

DNB Job Number:	RV58044-001	Date:	Dec 17 2014	<b>Specification</b> FCC 47 CFR 2.1051 87.139
Customer:	ACSS, an L-3 Communications & Thales Company			
Model Number:	NGT-9000			
Description:	Diversity Mode-S Transponder	S/N:	N/A	
Test Equipment: (See pg. 11)	Asset #'s: 2047, 3066, 3635, 2264			
EUT performed within the requirements of the applicable Standard(s) YES <input checked="" type="checkbox"/> NO <input type="checkbox"/> SIGNED Thomas Elders				

### XPDR Conducted Spurious top port 3270MHz

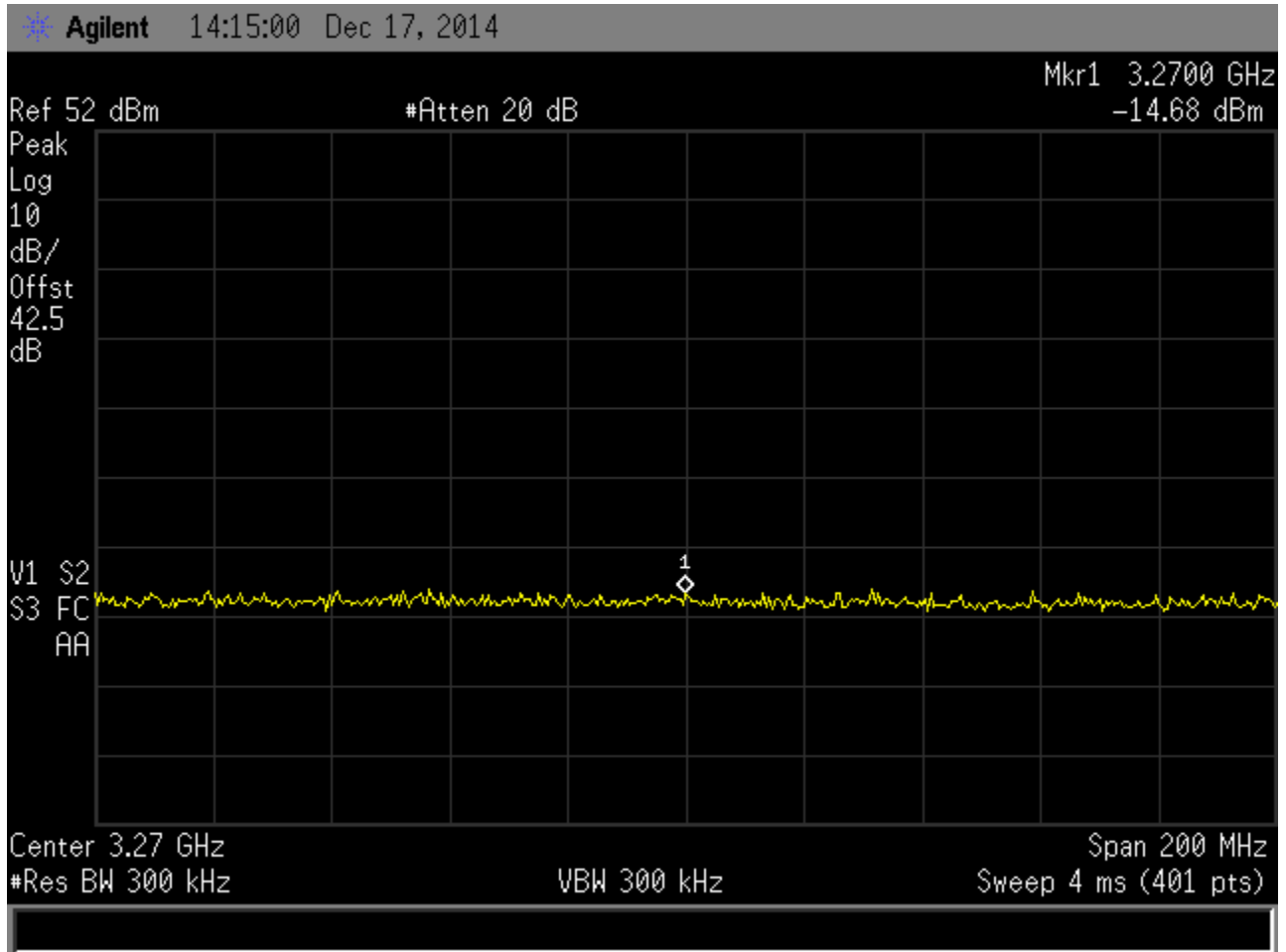





5969 Robinson Ave  
 Riverside, CA 92503  
 (951) 637-2630  
 FAX (951) 637-2704  
 www.dnbenginc.com

13 Jan 2015  
 RV58044-001

### Spurious Emissions at antenna terminals

DNB Job Number:	RV58044-001	Date:	Dec 17 2014	<b>Specification</b> FCC 47 CFR 2.1051 87.139
Customer:	ACSS, an L-3 Communications & Thales Company			
Model Number:	NGT-9000			
Description:	Diversity Mode-S Transponder	S/N:	N/A	
Test Equipment: (See pg. 11)	Asset #'s: 2047, 3066, 3635, 2264			
EUT performed within the requirements of the applicable Standard(s) YES <input checked="" type="checkbox"/> NO <input type="checkbox"/> SIGNED Thomas Elders				

### XPDR Conducted Spurious top port 4360MHz

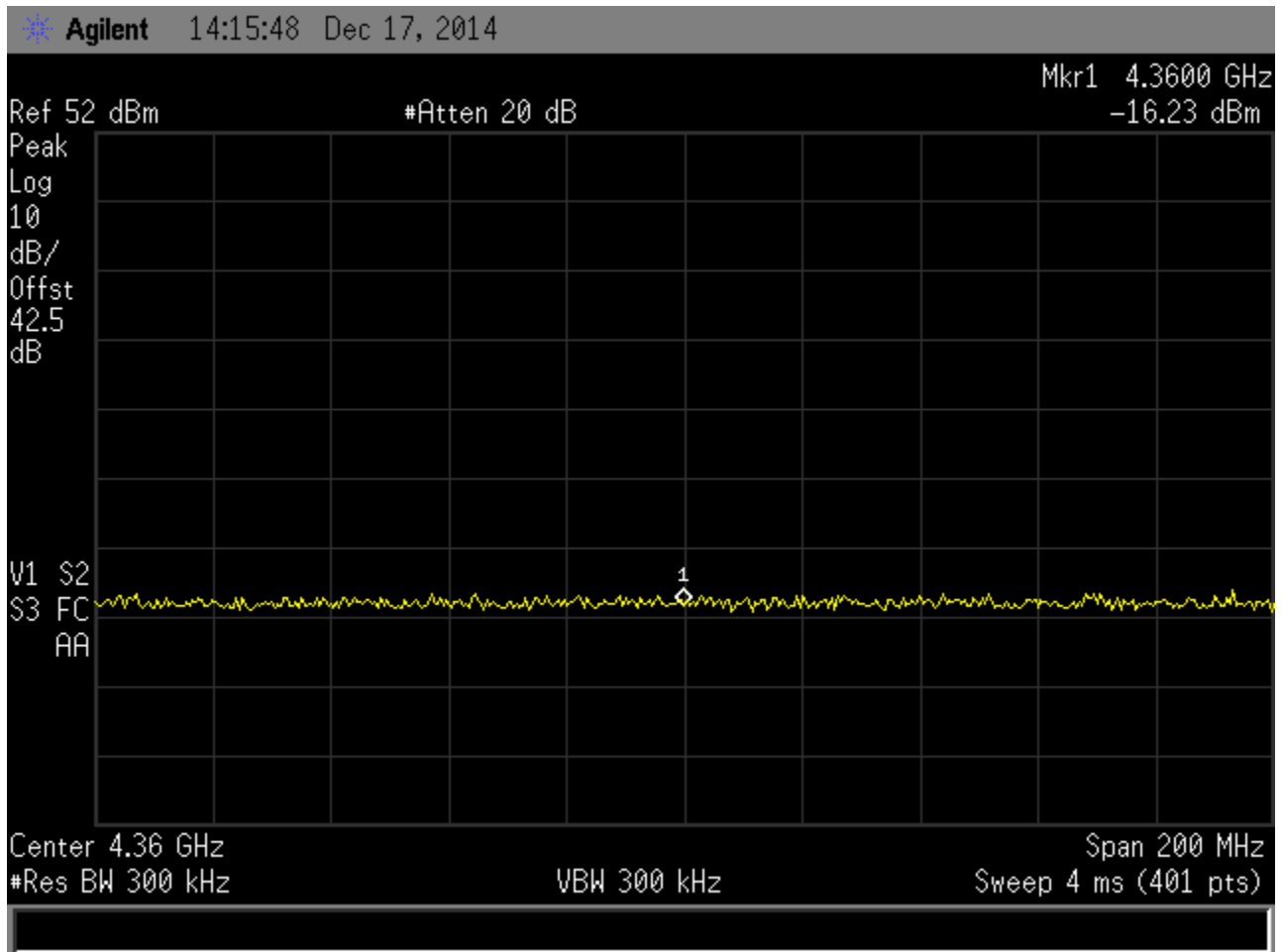



5969 Robinson Ave  
 Riverside, CA 92503  
 (951) 637-2630  
 FAX (951) 637-2704  
 www.dnbenginc.com

13 Jan 2015  
 RV58044-001

### Spurious Emissions at antenna terminals

DNB Job Number:	RV58044-001	Date:	Dec 17 2014	<b>Specification</b> FCC 47 CFR 2.1051 87.139
Customer:	ACSS, an L-3 Communications & Thales Company			
Model Number:	NGT-9000			
Description:	Diversity Mode-S Transponder	S/N:	N/A	
Test Equipment: (See pg. 11)	Asset #'s: 2047, 3066, 3635, 2264			
EUT performed within the requirements of the applicable Standard(s) YES <input checked="" type="checkbox"/> NO <input type="checkbox"/> SIGNED Thomas Elders				

### XPDR Conducted Spurious top port 5450MHz

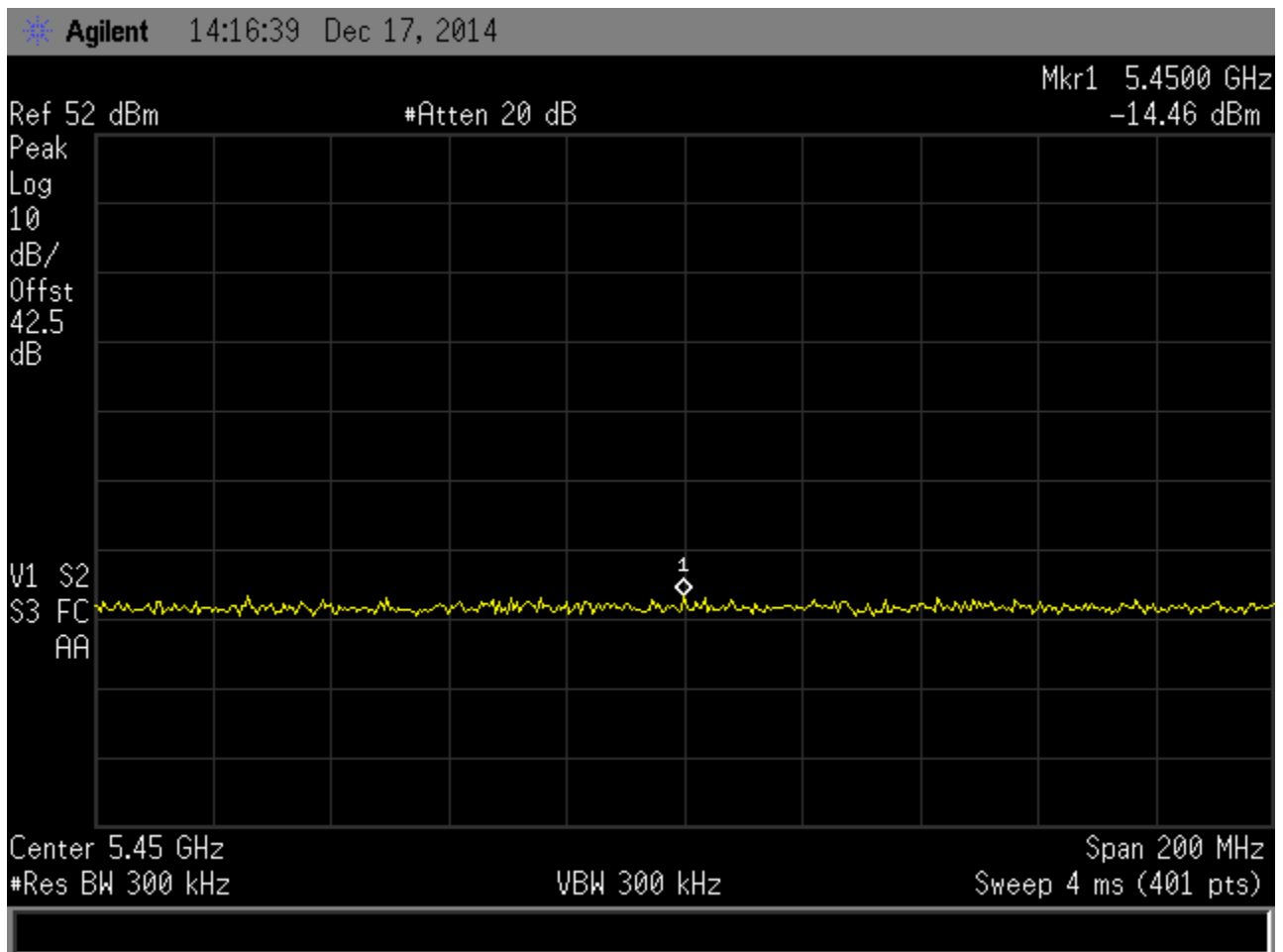



5969 Robinson Ave  
 Riverside, CA 92503  
 (951) 637-2630  
 FAX (951) 637-2704  
 www.dnbenginc.com

13 Jan 2015  
 RV58044-001

### Spurious Emissions at antenna terminals

DNB Job Number:	RV58044-001	Date:	Dec 17 2014	<b>Specification</b> FCC 47 CFR 2.1051 87.139
Customer:	ACSS, an L-3 Communications & Thales Company			
Model Number:	NGT-9000			
Description:	Diversity Mode-S Transponder	S/N:	N/A	
Test Equipment: (See pg. 11)	Asset #'s: 2047, 3066, 3635, 2264			
EUT performed within the requirements of the applicable Standard(s) YES <input checked="" type="checkbox"/> NO <input type="checkbox"/> SIGNED Thomas Elders				

### XPDR Conducted Spurious top port 6540MHz

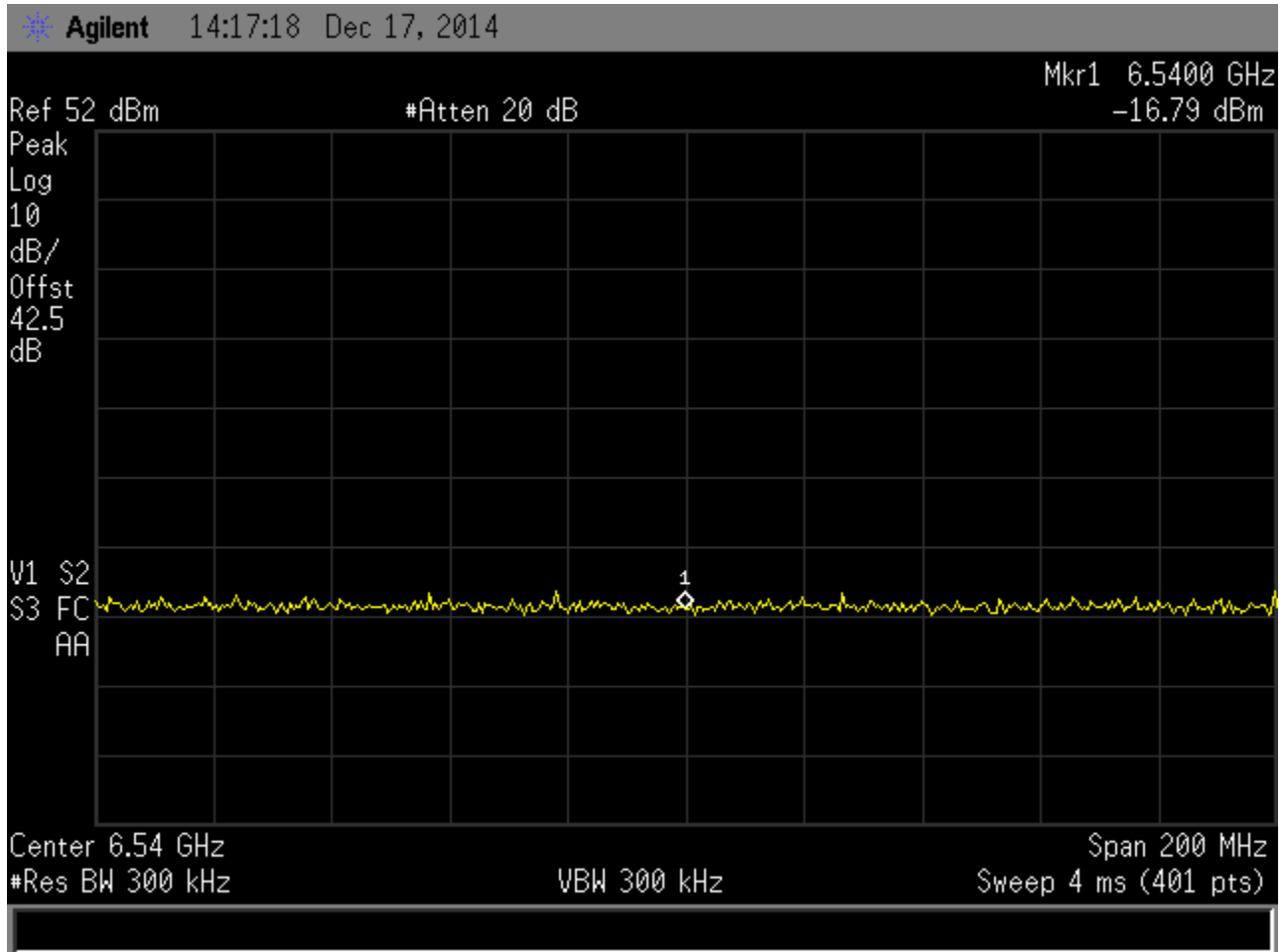



5969 Robinson Ave  
 Riverside, CA 92503  
 (951) 637-2630  
 FAX (951) 637-2704  
 www.dnbenginc.com

13 Jan 2015  
 RV58044-001

### Spurious Emissions at antenna terminals

DNB Job Number:	RV58044-001	Date:	Dec 17 2014	<b>Specification</b> FCC 47 CFR 2.1051 87.139
Customer:	ACSS, an L-3 Communications & Thales Company			
Model Number:	NGT-9000			
Description:	Diversity Mode-S Transponder	S/N:	N/A	
Test Equipment: (See pg. 11)	Asset #'s: 2047, 3066, 3635, 2264			
EUT performed within the requirements of the applicable Standard(s) YES <input checked="" type="checkbox"/> NO <input type="checkbox"/> SIGNED Thomas Elders				

### XPDR Conducted Spurious top port 7630MHz

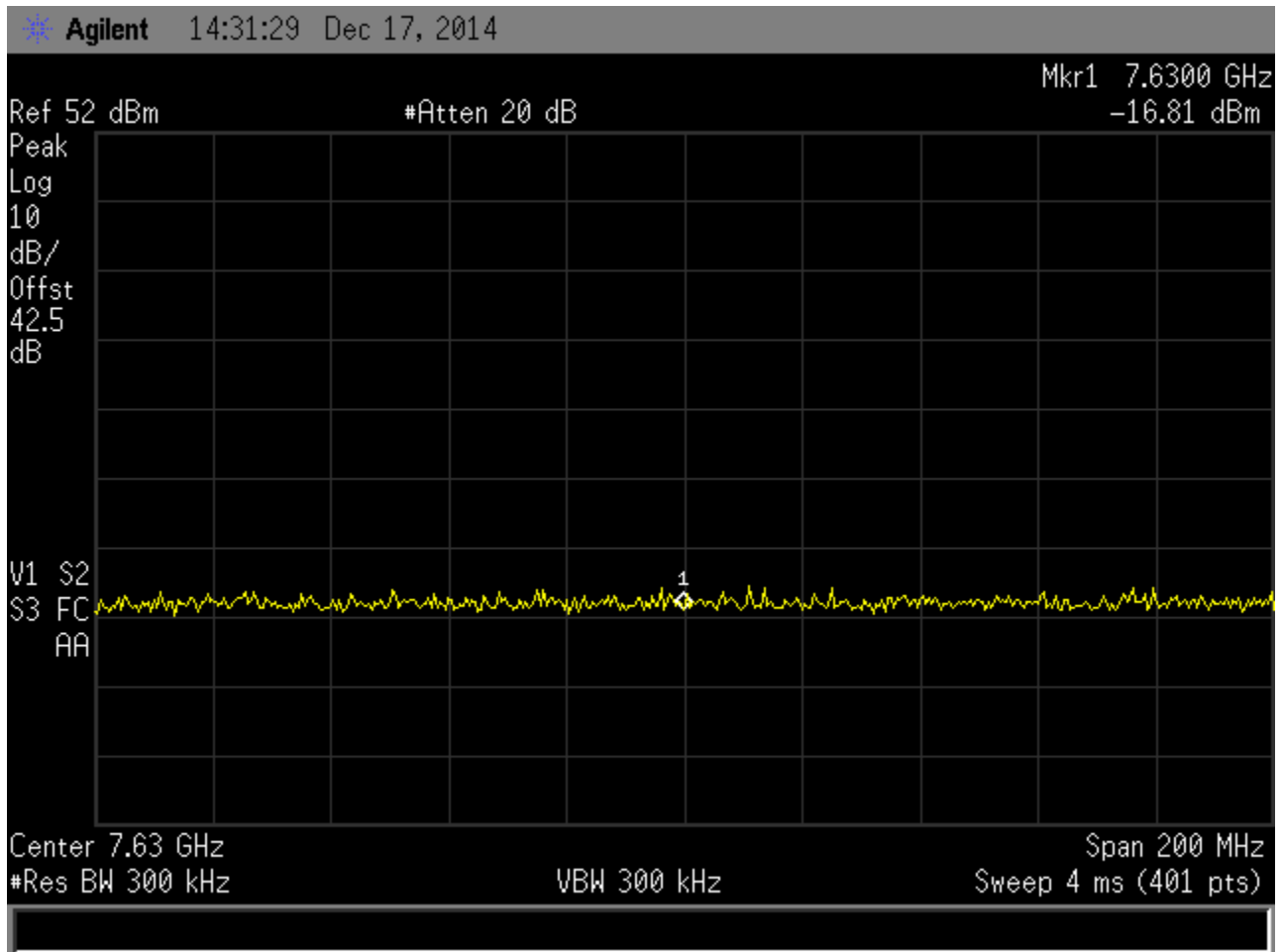



5969 Robinson Ave  
 Riverside, CA 92503  
 (951) 637-2630  
 FAX (951) 637-2704  
 www.dnbenginc.com

13 Jan 2015  
 RV58044-001

### Spurious Emissions at antenna terminals

DNB Job Number:	RV58044-001	Date:	Dec 17 2014	<b>Specification</b> FCC 47 CFR 2.1051 87.139
Customer:	ACSS, an L-3 Communications & Thales Company			
Model Number:	NGT-9000			
Description:	Diversity Mode-S Transponder	S/N:	N/A	
Test Equipment: (See pg. 11)	Asset #'s: 2047, 3066, 3635, 2264			
EUT performed within the requirements of the applicable Standard(s) YES <input checked="" type="checkbox"/> NO <input type="checkbox"/> SIGNED Thomas Elders				

### XPDR Conducted Spurious top port 8720MHz

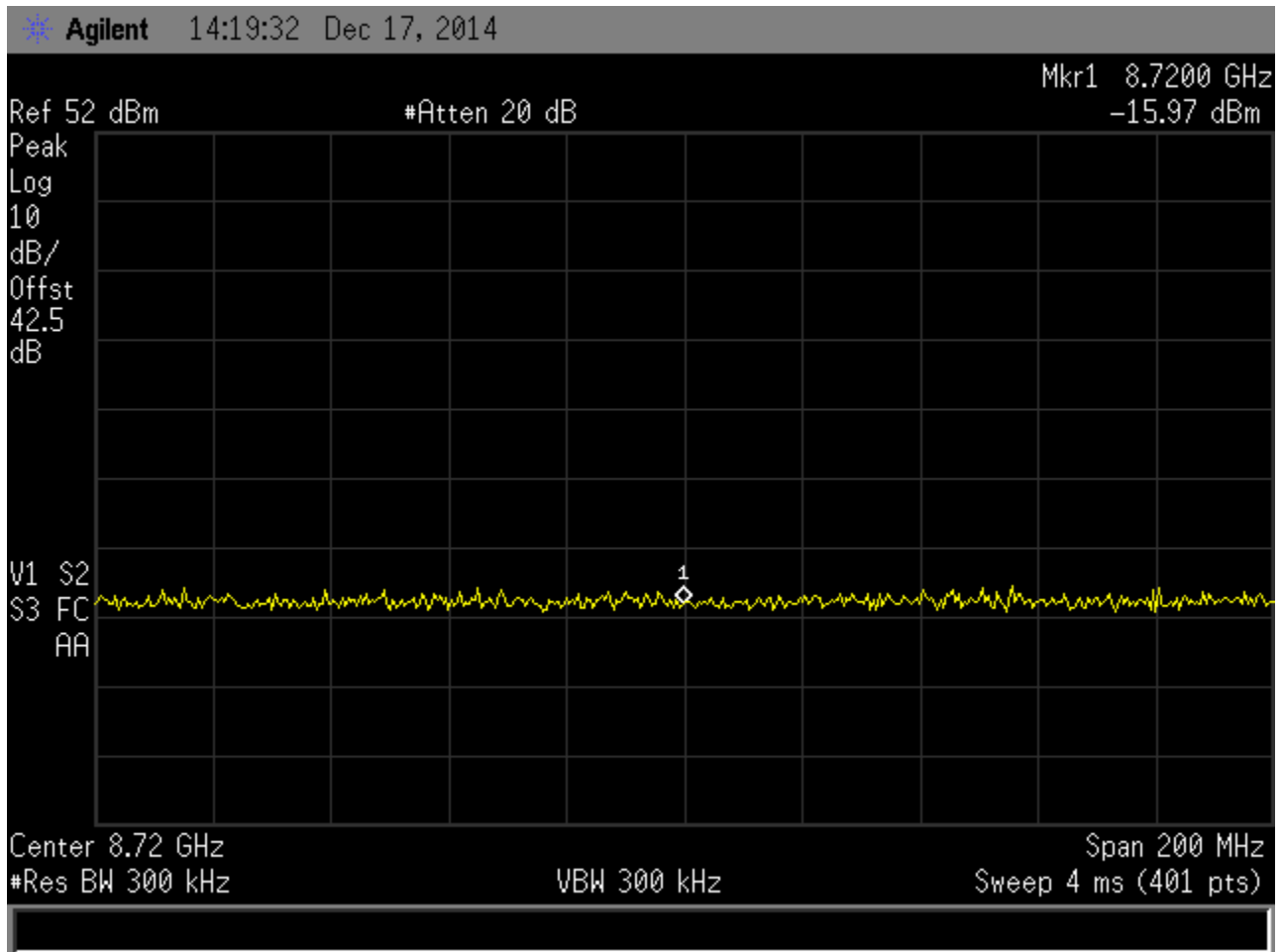



5969 Robinson Ave  
 Riverside, CA 92503  
 (951) 637-2630  
 FAX (951) 637-2704  
 www.dnbenginc.com

13 Jan 2015  
 RV58044-001

### Spurious Emissions at antenna terminals

DNB Job Number:	RV58044-001	Date:	Dec 17 2014	<b>Specification</b> FCC 47 CFR 2.1051 87.139
Customer:	ACSS, an L-3 Communications & Thales Company			
Model Number:	NGT-9000			
Description:	Diversity Mode-S Transponder	S/N:	N/A	
Test Equipment: (See pg. 11)	Asset #'s: 2047, 3066, 3635, 2264			
EUT performed within the requirements of the applicable Standard(s) YES <input checked="" type="checkbox"/> NO <input type="checkbox"/> SIGNED Thomas Elders				

### XPDR Conducted Spurious top port 9810MHz

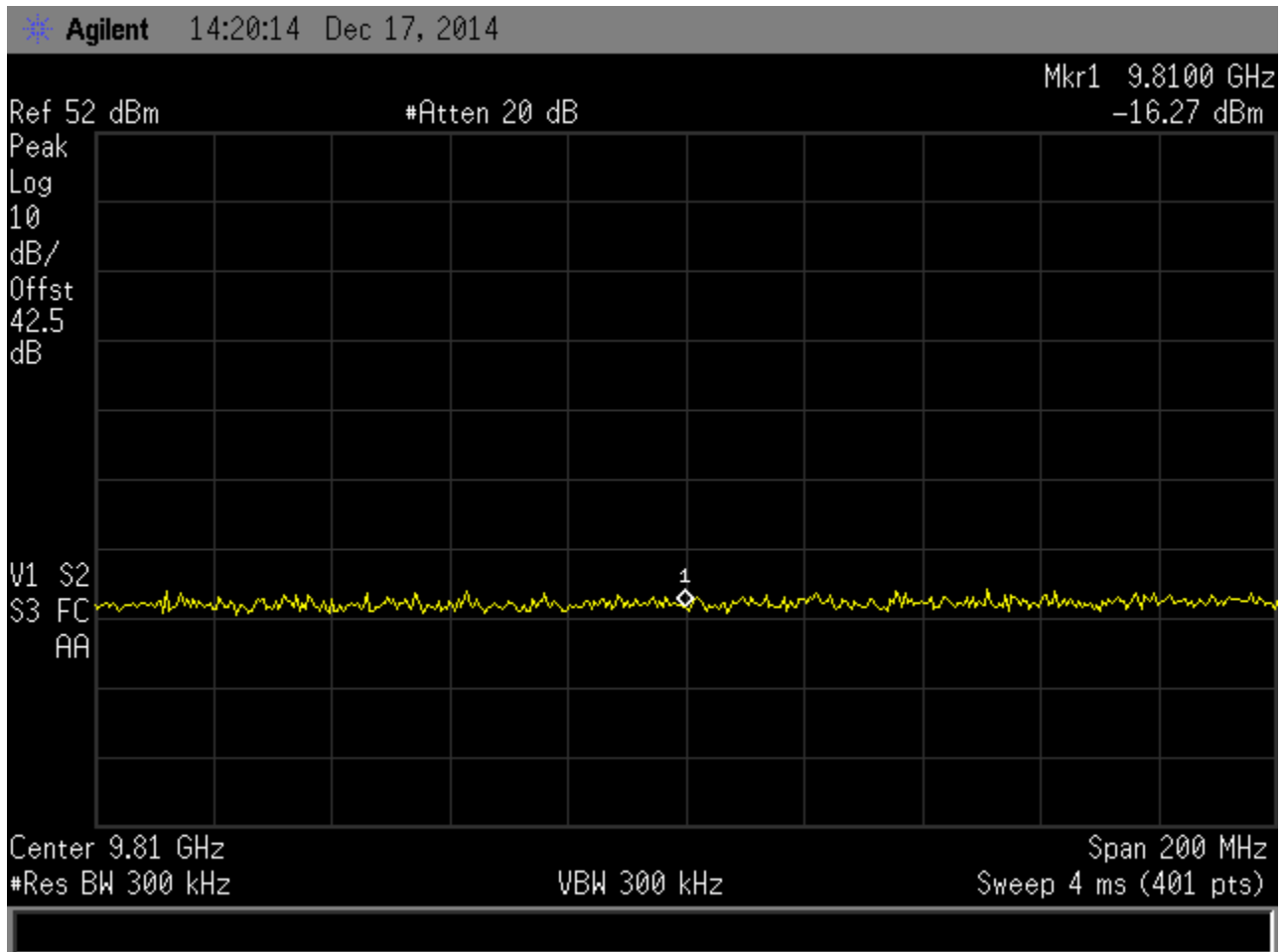



5969 Robinson Ave  
 Riverside, CA 92503  
 (951) 637-2630  
 FAX (951) 637-2704  
 www.dnbenginc.com

13 Jan 2015  
 RV58044-001

### Spurious Emissions at antenna terminals

DNB Job Number:	RV58044-001	Date:	Dec 17 2014	<b>Specification</b> FCC 47 CFR 2.1051 87.139
Customer:	ACSS, an L-3 Communications & Thales Company			
Model Number:	NGT-9000			
Description:	Diversity Mode-S Transponder	S/N:	N/A	
Test Equipment: (See pg. 11)	Asset #'s: 2047, 3066, 3635, 2264			
EUT performed within the requirements of the applicable Standard(s) YES <input checked="" type="checkbox"/> NO <input type="checkbox"/> SIGNED Thomas Elders				

### XPDR Conducted Spurious top port 10900MHz

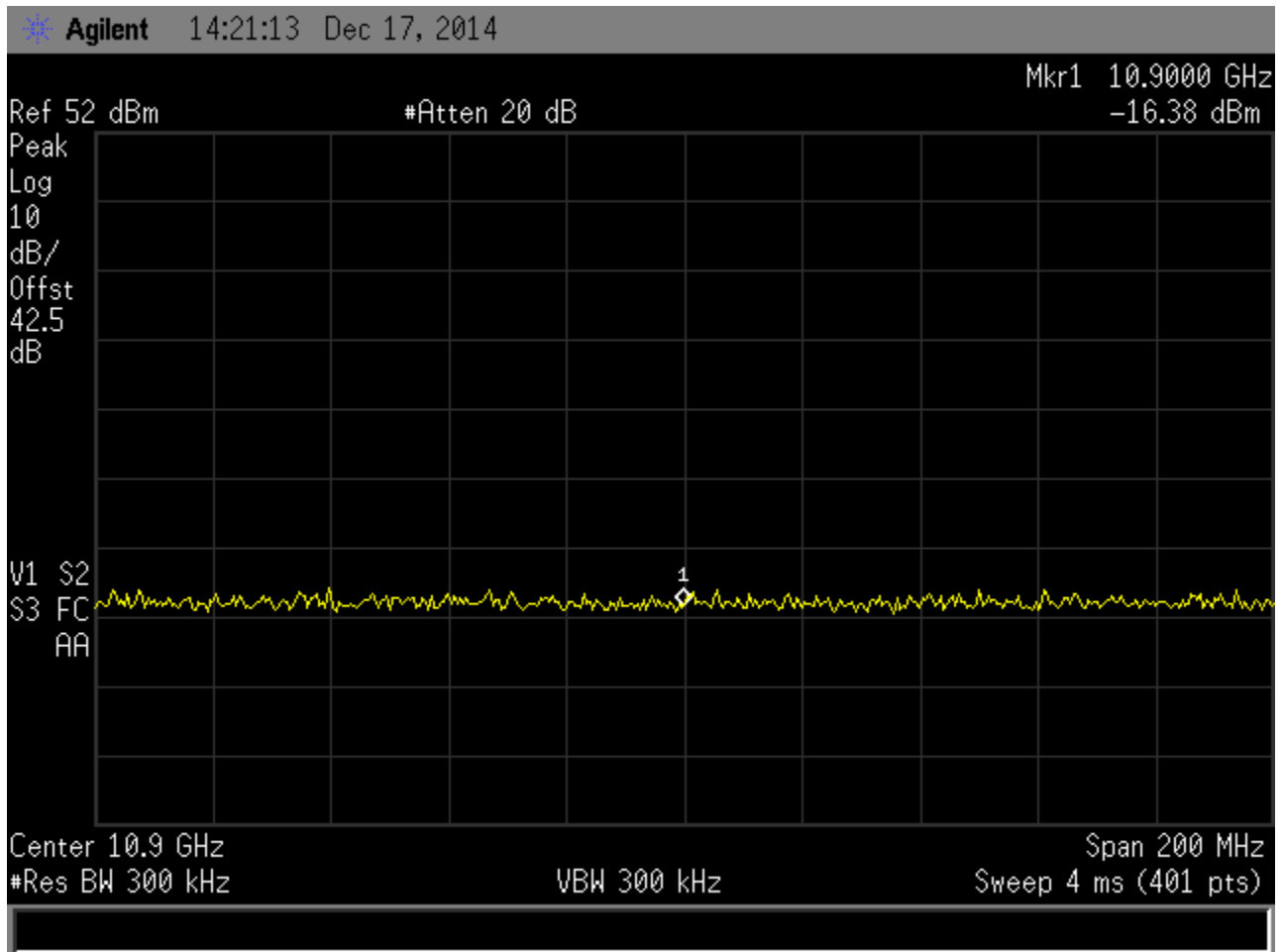



5969 Robinson Ave  
 Riverside, CA 92503  
 (951) 637-2630  
 FAX (951) 637-2704  
 www.dnbenginc.com

13 Jan 2015  
 RV58044-001

### Spurious Emissions at antenna terminals

DNB Job Number:	RV58044-001	Date:	Dec 17 2014	<b>Specification</b> FCC 47 CFR 2.1051 87.139
Customer:	ACSS, an L-3 Communications & Thales Company			
Model Number:	NGT-9000			
Description:	Diversity Mode-S Transponder	S/N:	N/A	
Test Equipment: (See pg. 11)	Asset #'s: 2047, 3066, 3635, 2264			
EUT performed within the requirements of the applicable Standard(s) YES <input checked="" type="checkbox"/> NO <input type="checkbox"/> SIGNED Thomas Elders				

### XPDR Conducted Spurious bottom port 30MHz – 2GHz

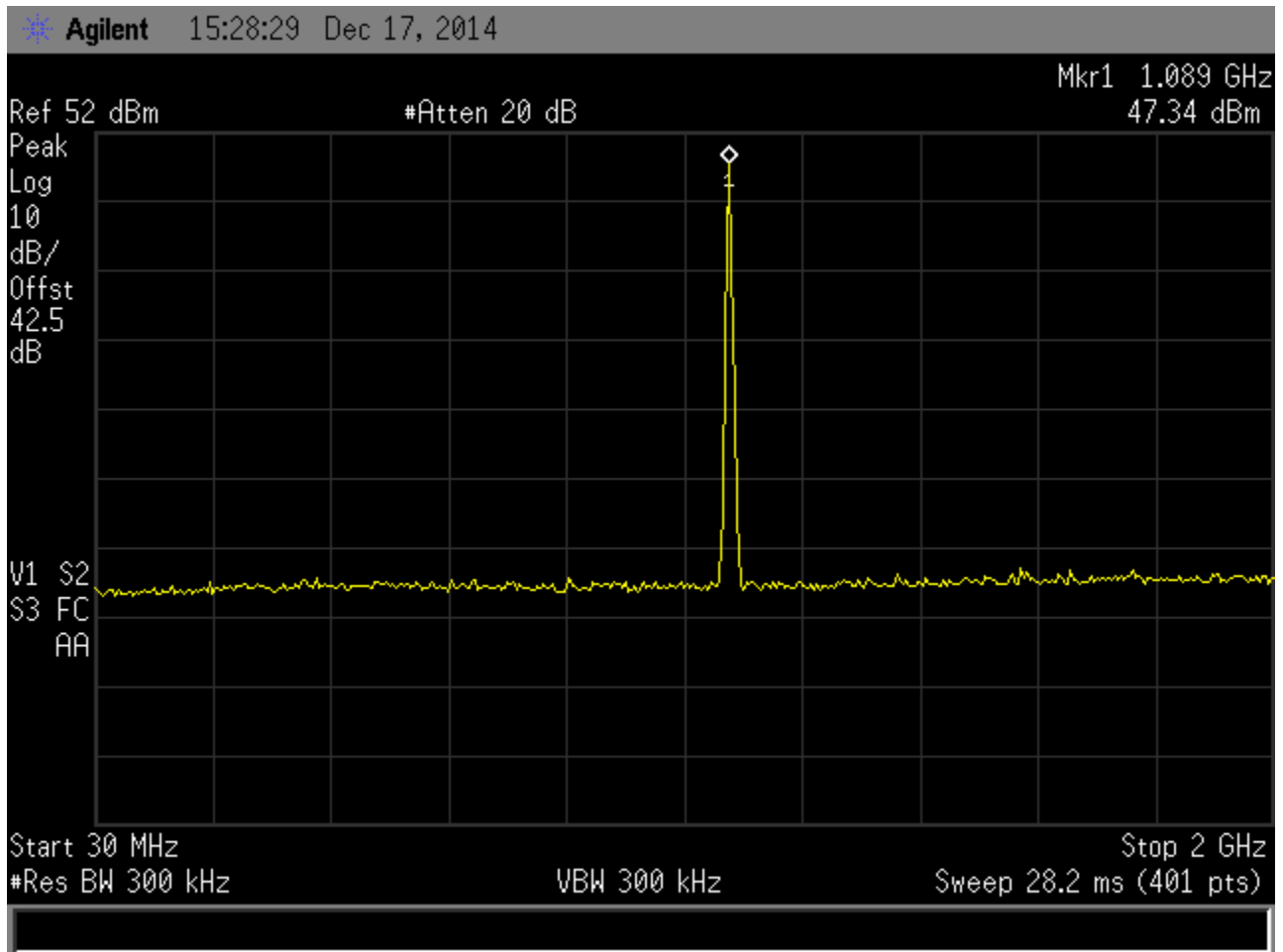





5969 Robinson Ave  
 Riverside, CA 92503  
 (951) 637-2630  
 FAX (951) 637-2704  
 www.dnbenginc.com

13 Jan 2015  
 RV58044-001

### Spurious Emissions at antenna terminals

DNB Job Number:	RV58044-001	Date:	Dec 17 2014	<b>Specification</b> FCC 47 CFR 2.1051 87.139
Customer:	ACSS, an L-3 Communications & Thales Company			
Model Number:	NGT-9000			
Description:	Diversity Mode-S Transponder	S/N:	N/A	
Test Equipment: (See pg. 11)	Asset #'s: 2047, 3066, 3635, 2264			
EUT performed within the requirements of the applicable Standard(s) YES <input checked="" type="checkbox"/> NO <input type="checkbox"/> SIGNED Thomas Elders				

### XPDR Conducted Spurious bottom port 2180MHz

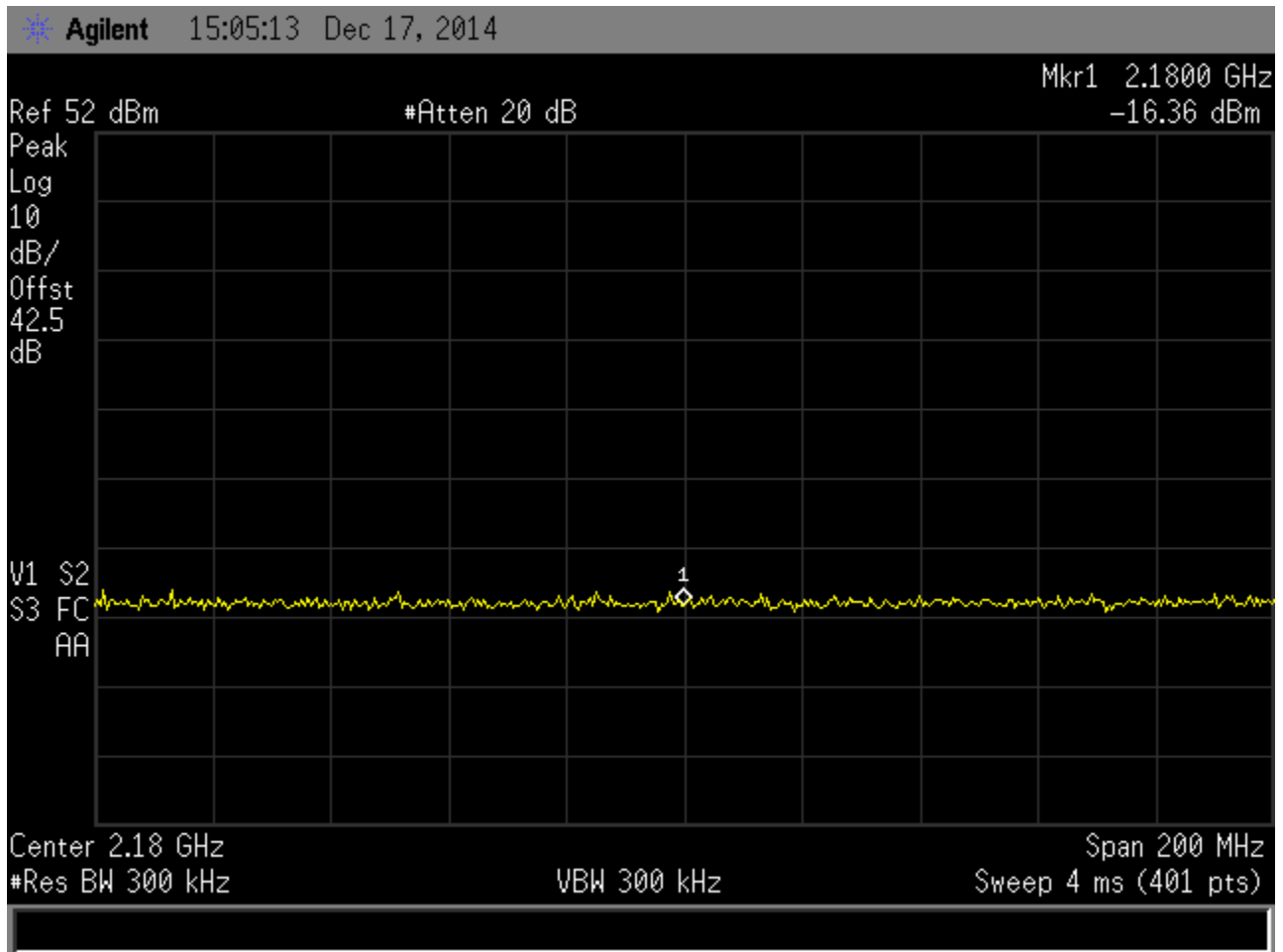



5969 Robinson Ave  
Riverside, CA 92503  
(951) 637-2630  
FAX (951) 637-2704  
www.dnbenginc.com

13 Jan 2015  
RV58044-001

### Spurious Emissions at antenna terminals

DNB Job Number:	RV58044-001	Date:	Dec 17 2014	<b>Specification</b> FCC 47 CFR 2.1051 87.139
Customer:	ACSS, an L-3 Communications & Thales Company			
Model Number:	NGT-9000			
Description:	Diversity Mode-S Transponder	S/N:	N/A	
Test Equipment: (See pg. 11)	Asset #'s: 2047, 3066, 3635, 2264			
EUT performed within the requirements of the applicable Standard(s) YES <input checked="" type="checkbox"/> NO <input type="checkbox"/> SIGNED Thomas Elders				

### XPDR Conducted Spurious bottom port 3270MHz

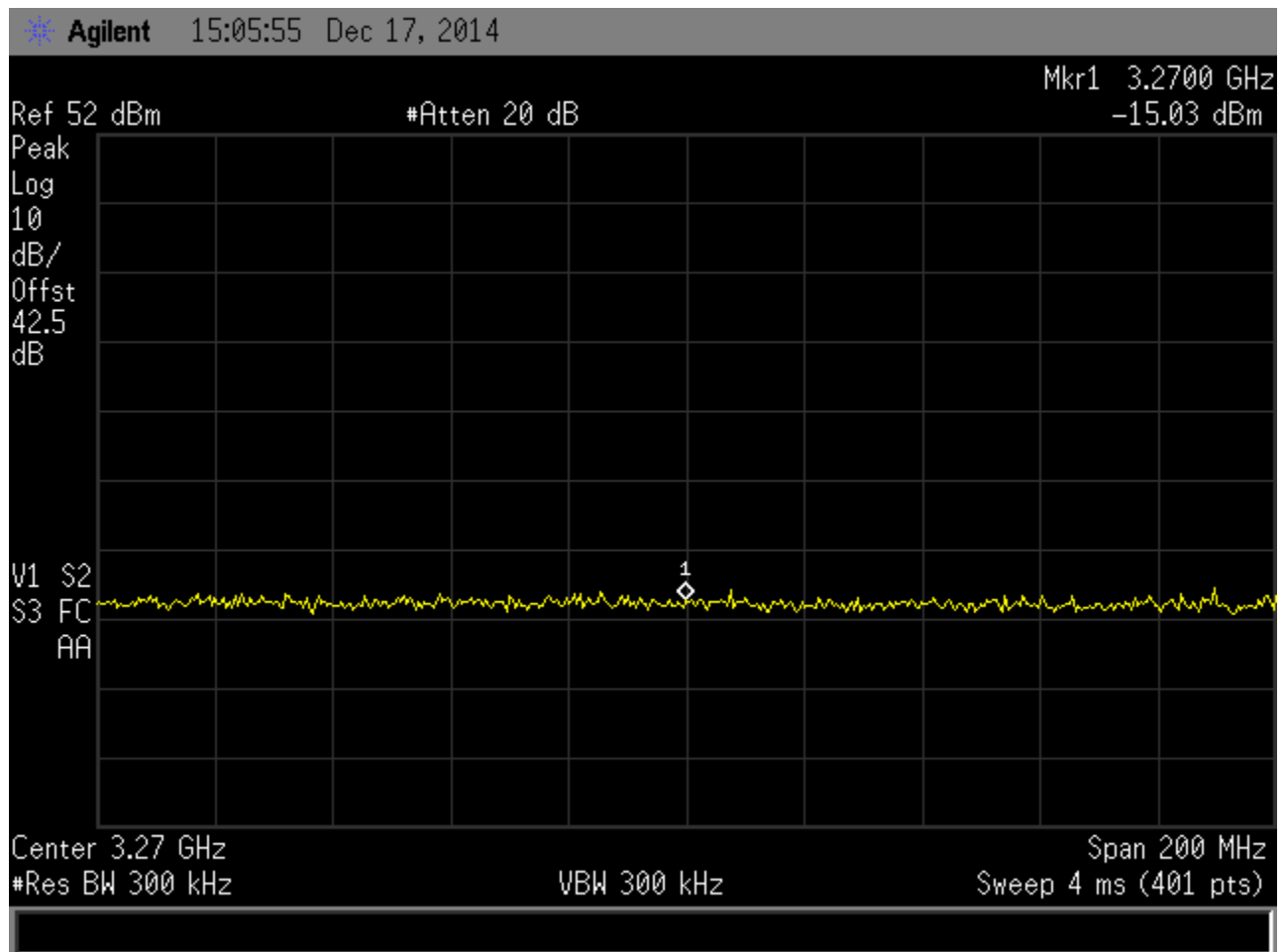



5969 Robinson Ave  
 Riverside, CA 92503  
 (951) 637-2630  
 FAX (951) 637-2704  
 www.dnbenginc.com

13 Jan 2015  
 RV58044-001

### Spurious Emissions at antenna terminals

DNB Job Number:	RV58044-001	Date:	Dec 17 2014	<b>Specification</b> FCC 47 CFR 2.1051 87.139
Customer:	ACSS, an L-3 Communications & Thales Company			
Model Number:	NGT-9000			
Description:	Diversity Mode-S Transponder	S/N:	N/A	
Test Equipment: (See pg. 11)	Asset #'s: 2047, 3066, 3635, 2264			
EUT performed within the requirements of the applicable Standard(s) YES <input checked="" type="checkbox"/> NO <input type="checkbox"/> SIGNED Thomas Elders				

### XPDR Conducted Spurious bottom port 4360MHz

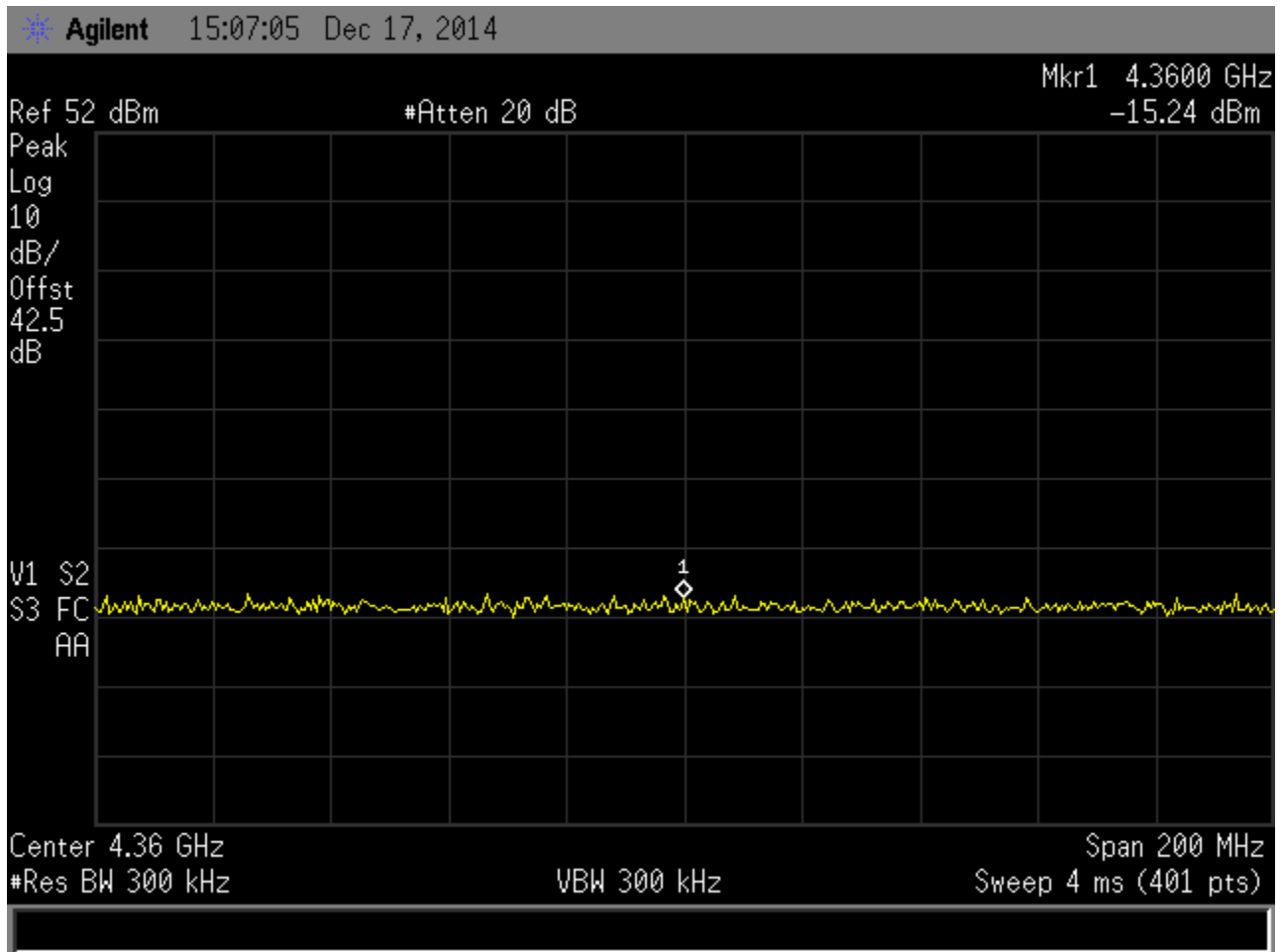



5969 Robinson Ave  
 Riverside, CA 92503  
 (951) 637-2630  
 FAX (951) 637-2704  
 www.dnbenginc.com

13 Jan 2015  
 RV58044-001

### Spurious Emissions at antenna terminals

DNB Job Number:	RV58044-001	Date:	Dec 17 2014	<b>Specification</b> FCC 47 CFR 2.1051 87.139
Customer:	ACSS, an L-3 Communications & Thales Company			
Model Number:	NGT-9000			
Description:	Diversity Mode-S Transponder	S/N:	N/A	
Test Equipment: (See pg. 11)	Asset #'s: 2047, 3066, 3635, 2264			
EUT performed within the requirements of the applicable Standard(s) YES <input checked="" type="checkbox"/> NO <input type="checkbox"/> SIGNED Thomas Elders				

### XPDR Conducted Spurious bottom port 5450MHz

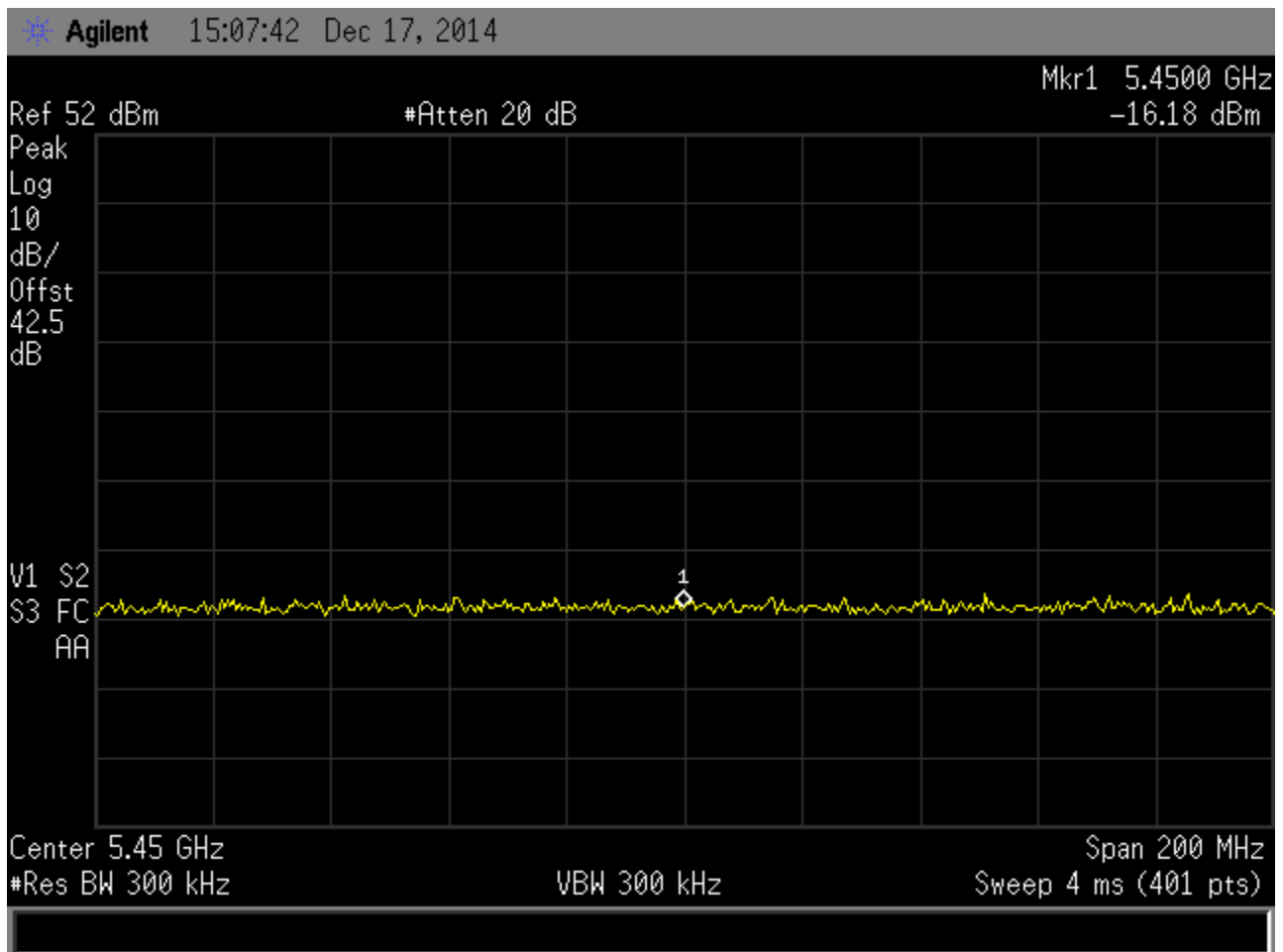



5969 Robinson Ave  
 Riverside, CA 92503  
 (951) 637-2630  
 FAX (951) 637-2704  
 www.dnbenginc.com

13 Jan 2015  
 RV58044-001

### Spurious Emissions at antenna terminals

DNB Job Number:	RV58044-001	Date:	Dec 17 2014	<b>Specification</b> FCC 47 CFR 2.1051 87.139
Customer:	ACSS, an L-3 Communications & Thales Company			
Model Number:	NGT-9000			
Description:	Diversity Mode-S Transponder	S/N:	N/A	
Test Equipment: (See pg. 11)	Asset #'s: 2047, 3066, 3635, 2264			
EUT performed within the requirements of the applicable Standard(s) YES <input checked="" type="checkbox"/> NO <input type="checkbox"/> SIGNED Thomas Elders				

### XPDR Conducted Spurious bottom port 6540MHz

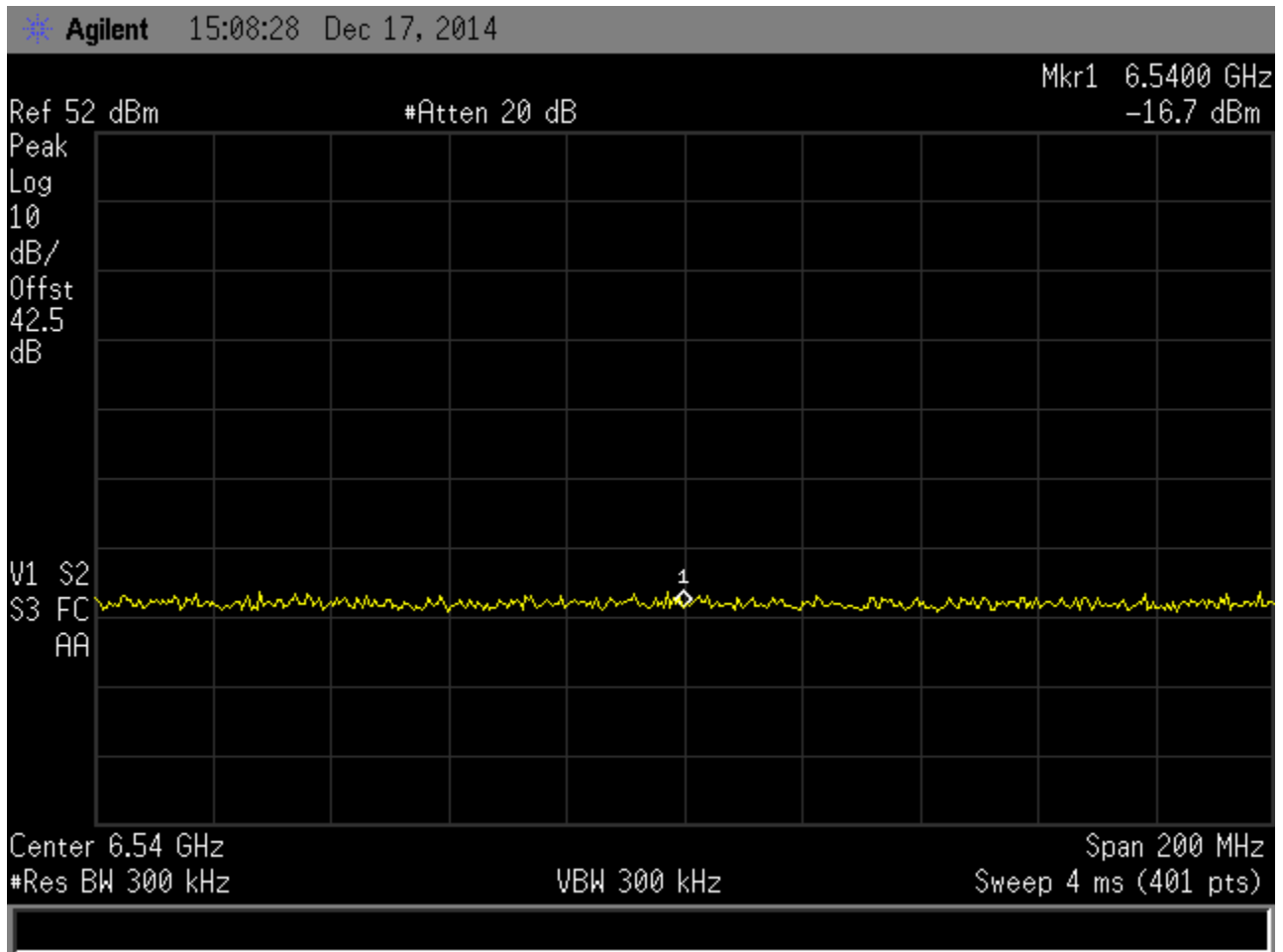



5969 Robinson Ave  
 Riverside, CA 92503  
 (951) 637-2630  
 FAX (951) 637-2704  
 www.dnbenginc.com

13 Jan 2015  
 RV58044-001

### Spurious Emissions at antenna terminals

DNB Job Number:	RV58044-001	Date:	Dec 17 2014	<b>Specification</b> FCC 47 CFR 2.1051 87.139
Customer:	ACSS, an L-3 Communications & Thales Company			
Model Number:	NGT-9000			
Description:	Diversity Mode-S Transponder	S/N:	N/A	
Test Equipment: (See pg. 11)	Asset #'s: 2047, 3066, 3635, 2264			
EUT performed within the requirements of the applicable Standard(s) YES <input checked="" type="checkbox"/> NO <input type="checkbox"/> SIGNED Thomas Elders				

### XPDR Conducted Spurious bottom port 7630MHz

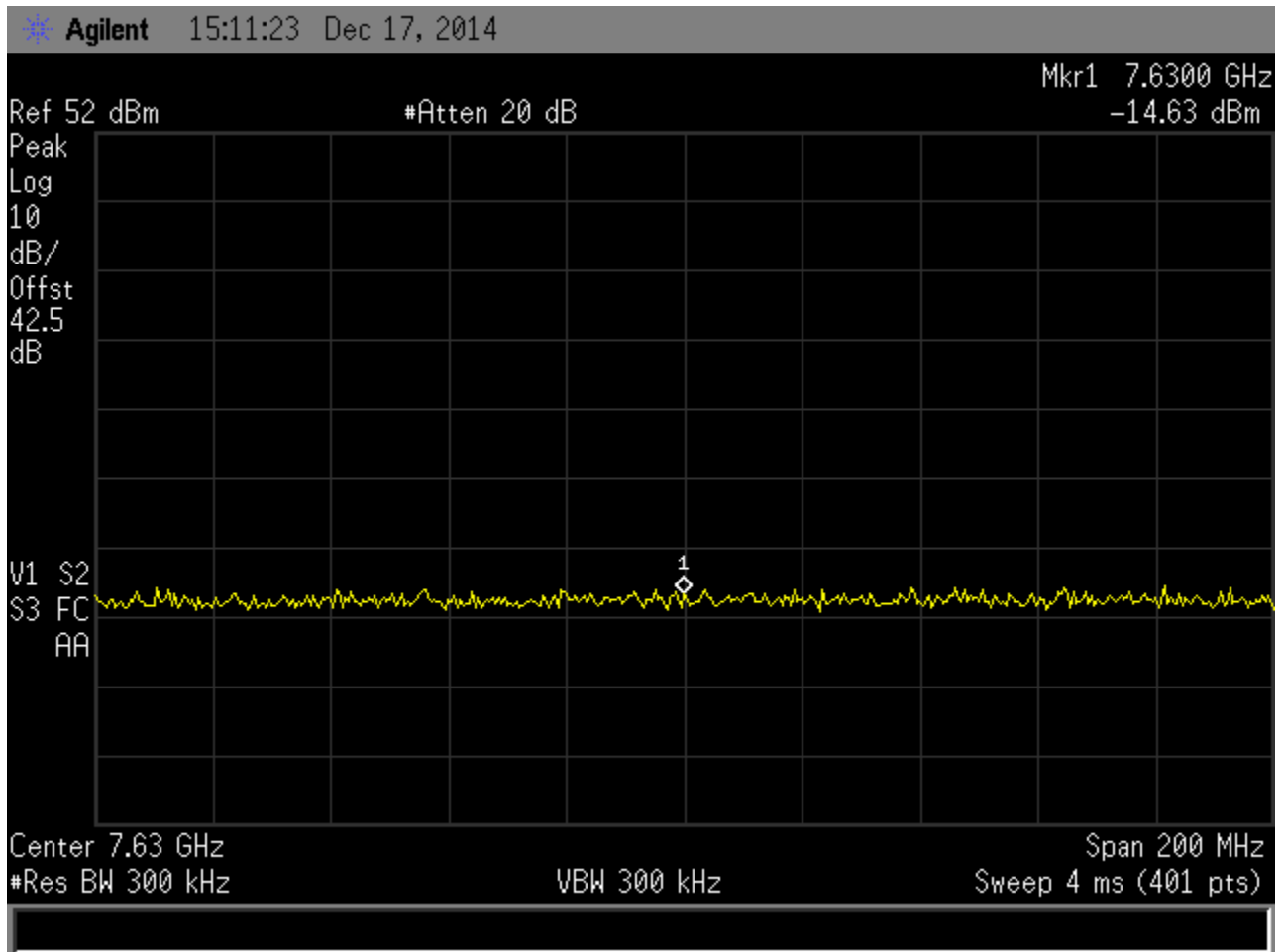



5969 Robinson Ave  
 Riverside, CA 92503  
 (951) 637-2630  
 FAX (951) 637-2704  
 www.dnbenginc.com

13 Jan 2015  
 RV58044-001

### Spurious Emissions at antenna terminals

DNB Job Number:	RV58044-001	Date:	Dec 17 2014	<b>Specification</b> FCC 47 CFR 2.1051 87.139
Customer:	ACSS, an L-3 Communications & Thales Company			
Model Number:	NGT-9000			
Description:	Diversity Mode-S Transponder	S/N:	N/A	
Test Equipment: (See pg. 11)	Asset #'s: 2047, 3066, 3635, 2264			
EUT performed within the requirements of the applicable Standard(s) YES <input checked="" type="checkbox"/> NO <input type="checkbox"/> SIGNED Thomas Elders				

### XPDR Conducted Spurious bottom port 8720MHz

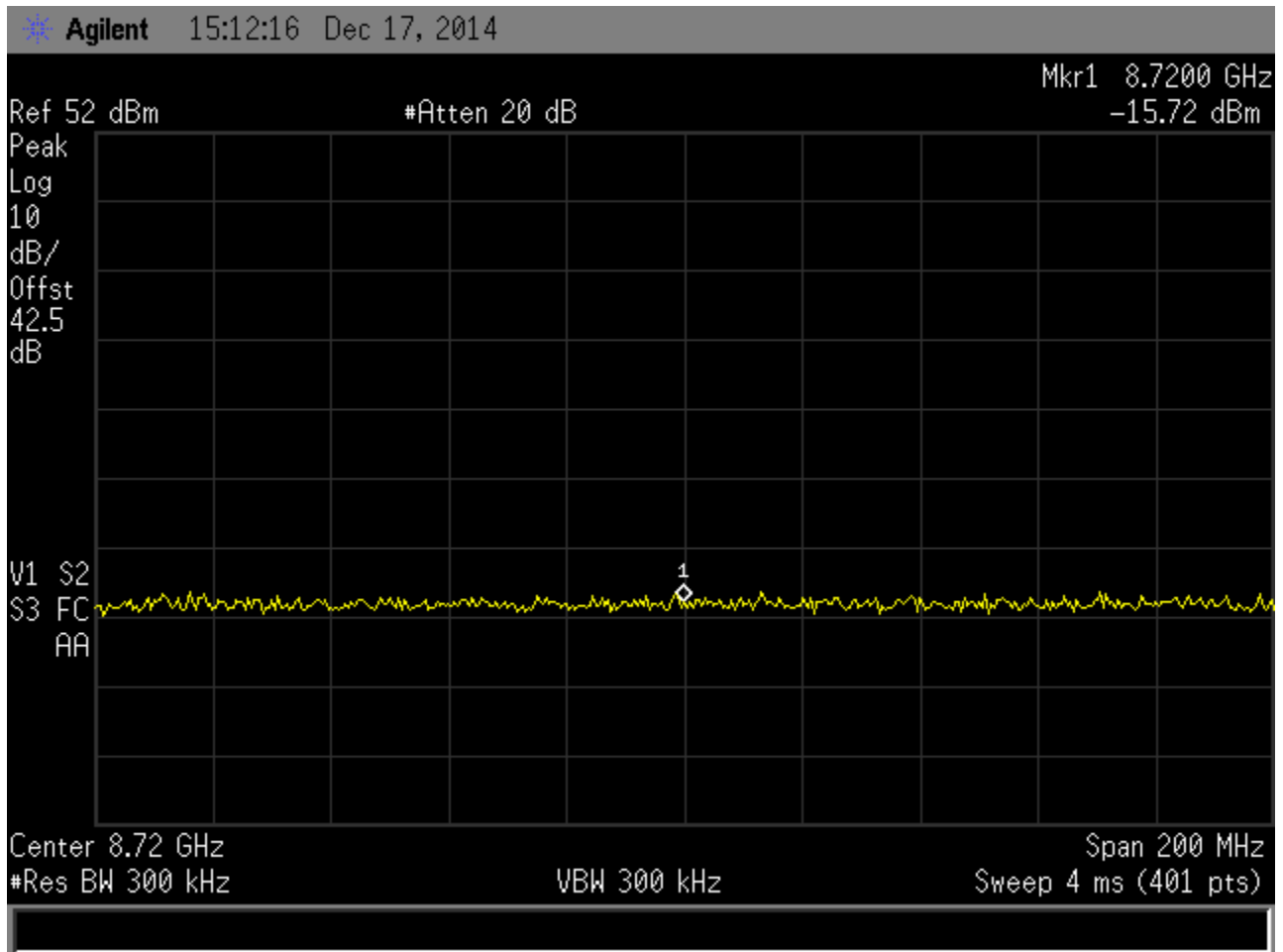



5969 Robinson Ave  
 Riverside, CA 92503  
 (951) 637-2630  
 FAX (951) 637-2704  
 www.dnbenginc.com

13 Jan 2015  
 RV58044-001

### Spurious Emissions at antenna terminals

DNB Job Number:	RV58044-001	Date:	Dec 17 2014	<b>Specification</b> FCC 47 CFR 2.1051 87.139
Customer:	ACSS, an L-3 Communications & Thales Company			
Model Number:	NGT-9000			
Description:	Diversity Mode-S Transponder	S/N:	N/A	
Test Equipment: (See pg. 11)	Asset #'s: 2047, 3066, 3635, 2264			
EUT performed within the requirements of the applicable Standard(s) YES <input checked="" type="checkbox"/> NO <input type="checkbox"/> SIGNED Thomas Elders				

### XPDR Conducted Spurious bottom port 9810MHz

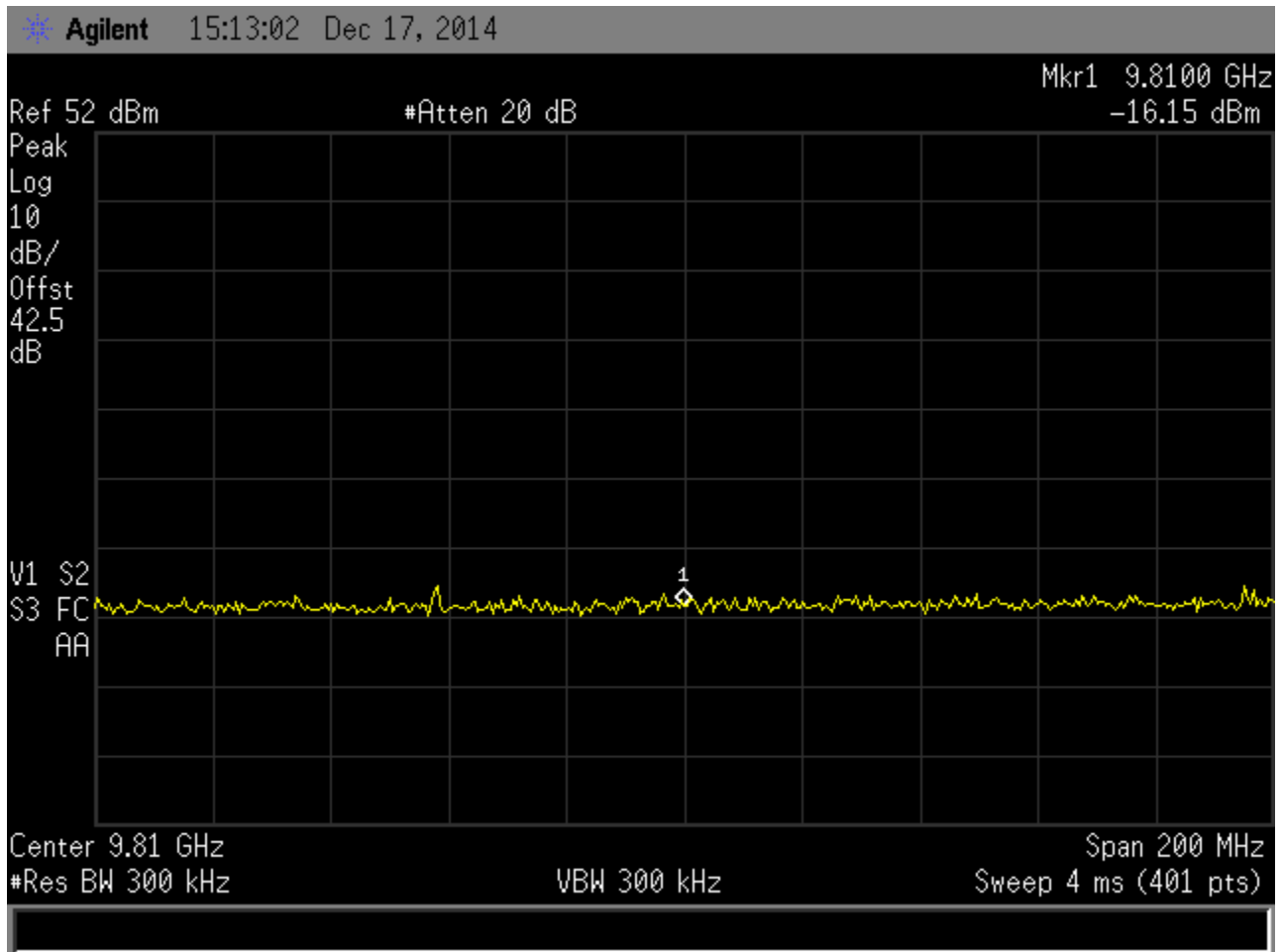





5969 Robinson Ave  
 Riverside, CA 92503  
 (951) 637-2630  
 FAX (951) 637-2704  
 www.dnbenginc.com

13 Jan 2015  
 RV58044-001

### Spurious Emissions at antenna terminals

DNB Job Number:	RV58044-001	Date:	Dec 17 2014	<b>Specification</b> FCC 47 CFR 2.1051 87.139
Customer:	ACSS, an L-3 Communications & Thales Company			
Model Number:	NGT-9000			
Description:	Diversity Mode-S Transponder	S/N:	N/A	
Test Equipment: (See pg. 11)	Asset #'s: 2047, 3066, 3635, 2264			
EUT performed within the requirements of the applicable Standard(s) YES <input checked="" type="checkbox"/> NO <input type="checkbox"/> SIGNED Thomas Elders				

### XPDR Conducted Spurious bottom port 10900MHz

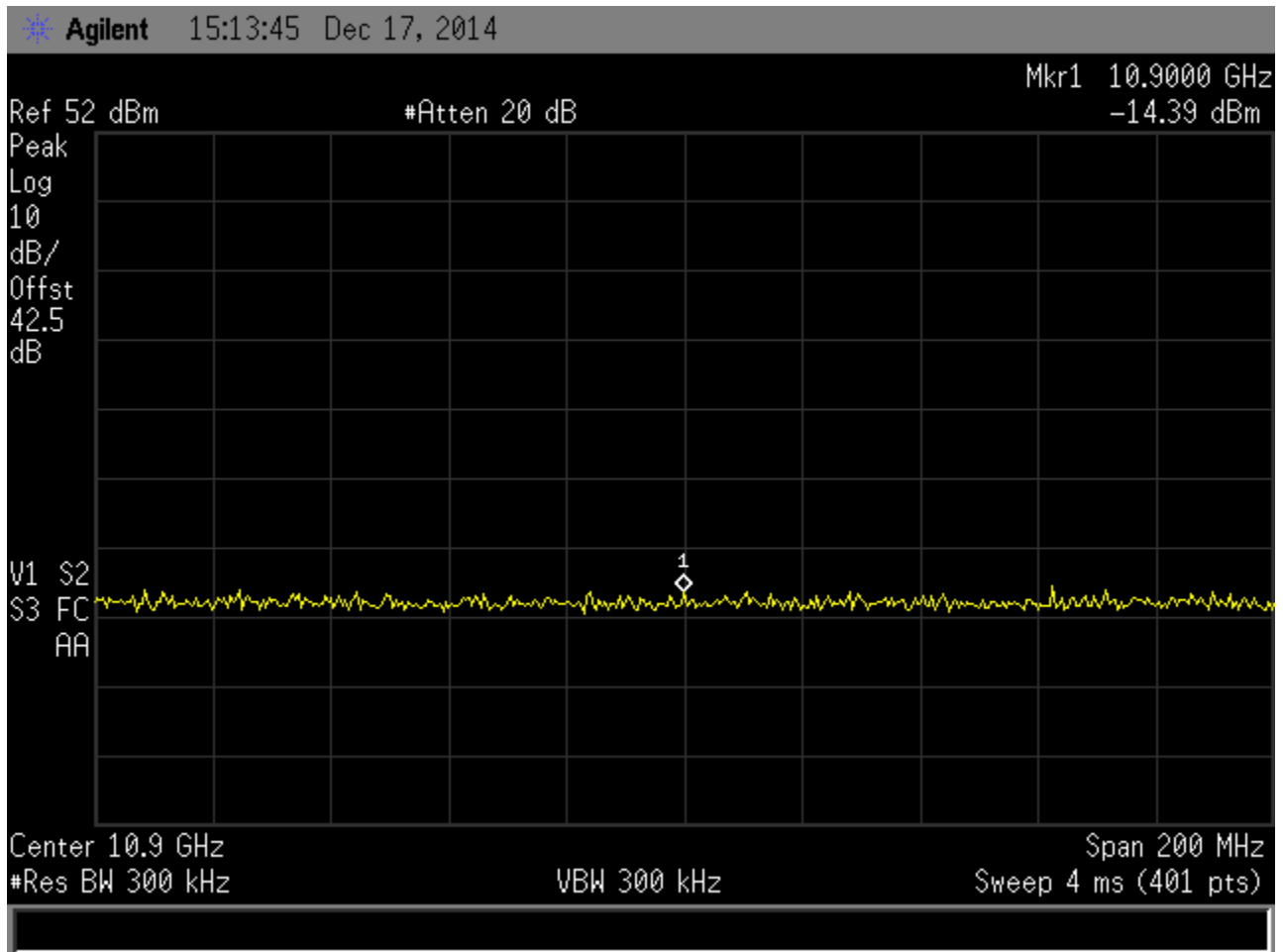



5969 Robinson Ave  
 Riverside, CA 92503  
 (951) 637-2630  
 FAX (951) 637-2704  
 www.dnbenginc.com

13 Jan 2015  
 RV58044-001

### Radiated Emissions

DNB Job Number:	RV58044-001	Date:	Dec 18 2014	<b>Specification</b> FCC 47 CFR 15.109 87.139
Customer:	ACSS, an L-3 Communications & Thales Company			
Model Number:	NGT-9000	Serial Number:	N/A	
Description:	Diversity Mode-S Transponder			
Test Equipment: (See pg. 11)	Asset #'s: 11, 31, 1758, 1874, 1875, 1880, 1760, 364, 1698, 1234, 1430, 1965			
EUT performed within the requirements of the applicable Standard(s) YES <input checked="" type="checkbox"/> NO <input type="checkbox"/> SIGNED Thomas Elders				

### Radiated emissions Class B Digital Devices 30MHz – 1GHz

Frequency (MHz)	Meter (dBµV)	Antenna (dB)	Cable (dB)	Preamp (dB)	Corrected (dBµV/m)	Limit (dBµV/m)	Delta (dB)	Detector	Table	Polarity
31.024	37.2	13.1	1.2	-21.9	29.6	40	-10.4	PK	36	V
31.626	34.8	13	1.3	-21.9	27.2	40	-12.8	PK	34	V
34.782	42	12.9	1.3	-21.9	34.3	40	-5.7	PK	34	H
35.275	32.3	12.8	1.3	-21.9	24.5	40	-15.5	PK	36	H
36.524	36.7	12.6	1.3	-21.9	28.7	40	-11.3	PK	36	V
37.126	37.8	12.4	1.3	-21.9	29.6	40	-10.4	PK	34	V
38.024	34.5	12.2	1.3	-21.9	26.1	40	-13.9	PK	36	V
41.238	47.7	11.6	1.4	-21.9	38.8	40	-1.2	PK	34	H
43.275	41.5	11.2	1.4	-21.8	32.3	40	-7.7	PK	36	H
48.264	32.9	10.5	1.5	-21.8	23.1	40	-16.9	PK	34	H
51.264	33.7	10.2	1.5	-21.8	23.6	40	-16.4	PK	34	H
52.738	30.5	10	1.5	-21.8	20.2	40	-19.8	PK	36	H
54.811	35.6	9.8	1.5	-21.8	25.1	40	-14.9	PK	36	V
55.126	33.8	9.8	1.6	-21.8	23.4	40	-16.6	PK	34	V
61.004	41	9.5	1.6	-21.8	30.3	40	-9.7	PK	36	V
63.485	28.7	9.4	1.6	-21.8	17.9	40	-22.1	PK	34	H
64.126	31.1	9.4	1.6	-21.8	20.3	40	-19.7	PK	34	V
70.26	31.4	9.4	1.7	-21.8	20.7	40	-19.3	PK	36	H
71.504	36.1	9.4	1.7	-21.8	25.4	40	-14.6	PK	36	V
72	36.9	9.4	1.7	-21.8	26.2	40	-13.8	PK	34	H
72.401	50	9.4	1.7	-21.8	39.3	40	-0.7	QP	36	V
80	39	9.1	1.8	-21.9	28	40	-12	PK	34	H
81.946	34.6	9.1	1.8	-21.9	23.6	40	-16.4	PK	36	H
84.614	39.4	9.2	1.8	-21.9	28.5	40	-11.5	PK	36	V



5969 Robinson Ave  
Riverside, CA 92503  
(951) 637-2630  
FAX (951) 637-2704  
www.dnbenginc.com

13 Jan 2015  
RV58044-001

Frequency (MHz)	Meter (dB $\mu$ V)	Antenna (dB)	Cable (dB)	Preamplifier (dB)	Corrected (dB $\mu$ V/m)	Limit (dB $\mu$ V/m)	Delta (dB)	Detector	Table	Polarity
86.106	37.3	9.2	1.9	-21.9	26.5	40	-13.5	PK	34	V
87.446	36.2	9.2	1.9	-21.9	25.4	40	-14.6	PK	36	H
109.946	47.6	10.2	2.1	-21.9	38	43.5	-5.5	PK	36	H
109.993	46.3	10.2	2.1	-21.9	36.7	43.5	-6.8	PK	36	V
111.106	34.7	10.3	2.1	-21.9	25.2	43.5	-18.3	PK	34	V
117.5	39.2	10.8	2.2	-21.9	30.3	43.5	-13.2	PK	34	H
120.006	46.2	10.9	2.2	-21.9	37.4	43.5	-6.1	PK	36	V
123.106	28.3	11.1	2.2	-21.9	19.7	43.5	-23.8	PK	34	V
128	45.9	11.4	2.3	-21.9	37.7	43.5	-5.8	PK	34	H
128.031	42.1	11.4	2.3	-21.9	33.9	43.5	-9.6	PK	36	H
139.106	35.4	11.9	2.4	-21.9	27.8	43.5	-15.7	PK	34	V
144	41.6	12.1	2.4	-21.9	34.2	43.5	-9.3	PK	34	H
150.011	43.7	12.4	2.5	-21.8	36.8	43.5	-6.7	PK	36	H
150.012	43.4	12.4	2.5	-21.8	36.5	43.5	-7	PK	34	H
150.024	49.1	12.4	2.5	-21.8	42.2	43.5	-1.3	QP	36	V
151.117	32.8	12.4	2.5	-21.8	25.9	43.5	-17.6	PK	34	V
159.126	42	12.8	2.6	-21.8	35.6	43.5	-7.9	PK	34	H
169.73	42.1	13.2	2.7	-21.8	36.2	43.5	-7.3	PK	36	H
171.412	44.9	13.3	2.7	-21.8	39.1	43.5	-4.4	PK	36	H
181.54	36.7	14	2.8	-21.8	31.7	43.5	-11.8	PK	36	V
193.126	33.9	14.3	2.9	-21.8	29.3	43.5	-14.2	PK	34	H
194.916	38.2	14.3	2.9	-21.8	33.6	43.5	-9.9	PK	34	V
196.344	38.5	14.4	3	-21.8	34.1	43.5	-9.4	PK	36	H
204.986	40.8	10.9	3	-21.8	32.9	43.5	-10.6	PK	44	V
205.535	42	10.8	3	-21.8	34	43.5	-9.5	PK	48	H
206.054	43.7	10.8	3	-21.8	35.7	43.5	-7.8	PK	36	H
209.978	50	10.7	3.1	-21.8	42	43.5	-1.5	QP	36	H
209.997	52.2	10.7	3.1	-21.8	44.2	43.5	0.7	PK	36	H
217.464	43.3	10.6	3.1	-21.8	35.2	46	-10.8	PK	44	V
220.695	45.5	10.6	3.2	-21.8	37.5	46	-8.5	PK	44	V
222.87	37.9	10.6	3.2	-21.8	29.9	46	-16.1	PK	44	V
224.879	53.2	10.6	3.2	-21.8	45.2	46	-0.8	PK	44	V
224.886	52.5	10.6	3.2	-21.8	44.5	46	-1.5	QP	44	V
232.997	39.6	10.7	3.2	-21.7	31.8	46	-14.2	PK	44	H
244.815	45.8	11.4	3.3	-21.7	38.8	46	-7.2	PK	48	H
247.497	34.8	11.5	3.3	-21.7	27.9	46	-18.1	PK	44	H
256.005	38.5	11.9	3.4	-21.7	32.1	46	-13.9	PK	44	V
263.974	34.9	12.2	3.5	-21.7	28.9	46	-17.1	PK	44	H



5969 Robinson Ave  
 Riverside, CA 92503  
 (951) 637-2630  
 FAX (951) 637-2704  
 www.dnbenginc.com

13 Jan 2015  
 RV58044-001

Frequency (MHz)	Meter (dBμV)	Antenna (dB)	Cable (dB)	Preamp (dB)	Corrected (dBμV/m)	Limit (dBμV/m)	Delta (dB)	Detector	Table	Polarity
265.53	37.9	12.2	3.5	-21.7	31.9	46	-14.1	PK	44	V
265.922	40.4	12.2	3.5	-21.7	34.4	46	-11.6	PK	44	H
266.435	40.8	12.3	3.5	-21.7	34.9	46	-11.1	PK	44	V
272.038	41.4	12.6	3.5	-21.7	35.8	46	-10.2	PK	44	H
273.566	38.8	12.7	3.5	-21.7	33.3	46	-12.7	PK	58	H
273.566	36.8	12.7	3.5	-21.7	31.3	46	-14.7	PK	58	V
273.604	39.7	12.7	3.5	-21.7	34.2	46	-11.8	PK	58	V
273.622	48.8	12.7	3.5	-21.7	43.3	46	-2.7	PK	106	H
273.625	48	12.7	3.5	-21.7	42.5	46	-3.5	QP	106	H
276.008	36.7	12.9	3.6	-21.6	31.6	46	-14.4	PK	44	H
288.009	46.9	13.3	3.6	-21.6	42.2	46	-3.8	PK	48	V
288.026	40.1	13.3	3.6	-21.6	35.4	46	-10.6	PK	44	H
290.029	39.2	13.3	3.7	-21.6	34.6	46	-11.4	PK	44	H
300.686	35	13.8	3.7	-21.6	30.9	46	-15.1	PK	48	V
302.395	45.2	13.9	3.8	-21.6	41.3	46	-4.7	PK	48	V
310.019	40.2	14.7	3.8	-21.6	37.1	46	-8.9	PK	48	V
312.002	36.3	14.6	3.8	-21.6	33.1	46	-12.9	PK	44	H
352.5	29.8	14.7	4.1	-21.5	27.1	46	-18.9	PK	44	H
366.34	36.2	14.7	4.2	-21.5	33.6	46	-12.4	PK	44	V
390.005	36.9	14.6	4.4	-21.4	34.5	46	-11.5	PK	44	V
403.49	35.2	15.1	4.5	-21.4	33.4	46	-12.6	PK	44	H
409.995	34.6	15.3	4.5	-21.4	33	46	-13	PK	48	V
460.005	39.4	16.2	4.9	-21.3	39.2	46	-6.8	PK	44	V
490	34.5	17.5	5.1	-21.2	35.9	46	-10.1	PK	44	H
490.005	34.1	17.5	5.1	-21.2	35.5	46	-10.5	PK	44	V
504.81	32.4	17.5	5.2	-21.2	33.9	46	-12.1	PK	48	V
511.745	31.2	17.7	5.2	-21.2	32.9	46	-13.1	PK	48	H
520.02	37.7	17.9	5.3	-21.2	39.7	46	-6.3	PK	44	V
572	33.6	18.6	5.5	-21.2	36.5	46	-9.5	PK	44	H
660.02	33.8	19.5	5.8	-21.2	37.9	46	-8.1	PK	44	H
662.335	39.5	19.8	5.8	-21.2	43.9	46	-2.1	PK	48	H
709.21	31.9	20.2	6	-21.2	36.9	46	-9.1	PK	44	V
711.27	31.6	20.1	6	-21.2	36.5	46	-9.5	PK	48	V
719.995	35.3	19.8	6	-21.2	39.9	46	-6.1	PK	44	H
720.045	35.2	19.8	6	-21.2	39.8	46	-6.2	PK	44	V
722.365	31.6	19.9	6	-21.2	36.3	46	-9.7	PK	48	H
803.79	28.2	20.3	6.4	-21.3	33.6	46	-12.4	PK	48	H
810.92	30.7	20.5	6.4	-21.3	36.3	46	-9.7	PK	44	H



5969 Robinson Ave  
Riverside, CA 92503  
(951) 637-2630  
FAX (951) 637-2704  
www.dnbenginc.com

13 Jan 2015  
RV58044-001

Frequency (MHz)	Meter (dB $\mu$ V)	Antenna (dB)	Cable (dB)	Preamp (dB)	Corrected (dB $\mu$ V/m)	Limit (dB $\mu$ V/m)	Delta (dB)	Detector	Table	Polarity
902.77	32.5	21.6	6.7	-21.3	39.5	46	-6.5	PK	44	V
903.36	32.9	21.6	6.7	-21.3	39.9	46	-6.1	PK	48	V
906.565	33.1	21.8	6.7	-21.3	40.3	46	-5.7	PK	44	H
912.47	30.2	22.1	6.8	-21.3	37.8	46	-8.2	PK	48	H



5969 Robinson Ave  
 Riverside, CA 92503  
 (951) 637-2630  
 FAX (951) 637-2704  
 www.dnbenginc.com

13 Jan 2015  
 RV58044-001

### Field Strength of Radiated Spurious

DNB Job Number:	RV58044-001	Date:	Dec 18 2014	<b>Specification</b> FCC 47 CFR 2.1053 15.109 87.139
Customer:	ACSS, an L-3 Communications & Thales Company			
Model Number:	NGT-9000	Serial Number:	N/A	
Description:	Diversity Mode-S Transponder			
Test Equipment: (See pg. 11)	Asset #'s: 11, 364, 1698, 2079, 2264			
EUT performed within the requirements of the applicable Standard(s) YES <input checked="" type="checkbox"/> NO <input type="checkbox"/> SIGNED Thomas Elders				

### Radiated Spurious Emissions TAS 1GHz – 11GHz

Frequency (MHz)	Amplitude (dB $\mu$ V)	Antenna (dB)	Preamp (dB)	Cable (dB)	Corrected (dB $\mu$ V/m)	Polarity
2060	61	28	29	0.9	60.9	V
3090	60	31	29	1	63	V
4120	46	32	29	1.4	50.4	V
5150	34	34	29	1.5	40.5	V
6180	40	35	29	1.6	47.6	V
7210	27	37	29	1.7	36.7	V
8240	24	38	29	1.8	34.8	V
9270	20	38	29	1.9	30.9	V
10300	20	38	29	2	31	V
2060	55	28	29	0.9	54.9	H
3090	46	31	29	1	49	H
4120	28	32	29	1.4	32.4	H
5150	25	34	29	1.5	31.5	H
6180	29	35	29	1.6	36.6	H
7210	25	37	29	1.7	34.7	H
8240	22	38	29	1.8	32.8	H
9270	21	38	29	1.9	31.9	H
10300	21	38	29	2	32	H



5969 Robinson Ave  
 Riverside, CA 92503  
 (951) 637-2630  
 FAX (951) 637-2704  
 www.dnbenginc.com

13 Jan 2015  
 RV58044-001

### Field Strength of Radiated Spurious

DNB Job Number:	RV58044-001	Date:	Dec 18 2014	<b>Specification</b> FCC 47 CFR 2.1053 15.109 87.139
Customer:	ACSS, an L-3 Communications & Thales Company			
Model Number:	NGT-9000	Serial Number:	N/A	
Description:	Diversity Mode-S Transponder			
Test Equipment: (See pg. 11)	Asset #'s: 11, 364, 1698, 2079, 2264			
EUT performed within the requirements of the applicable Standard(s) YES <input checked="" type="checkbox"/> NO <input type="checkbox"/> SIGNED Thomas Elders				

### Radiated Spurious Emissions XPDR Top Port 1GHz – 11GHz

Frequency (MHz)	Amplitude (dBμV)	Antenna (dB)	Preamplifier (dB)	Cable (dB)	Corrected (dBμV/m)	Polarity
2180	85	28	29	0.9	84.9	V
3270	60	31	29	1	63	V
4360	67	32	29	1.4	71.4	V
5450	55	34	29	1.5	61.5	V
6540	44	35	29	1.6	51.6	V
7630	45	37	29	1.7	54.7	V
8720	27	38	29	1.8	37.8	V
9810	22	38	29	1.9	32.9	V
10900	21	38	29	2	32	V
2180	70	28	29	0.9	69.9	H
3270	40	31	29	1	43	H
4360	46	32	29	1.4	50.4	H
5450	41	34	29	1.5	47.5	H
6540	36	35	29	1.6	43.6	H
7630	26	37	29	1.7	35.7	H
8720	21	38	29	1.8	31.8	H
9810	20	38	29	1.9	30.9	H
10900	20	38	29	2	31	H



5969 Robinson Ave  
 Riverside, CA 92503  
 (951) 637-2630  
 FAX (951) 637-2704  
 www.dnbenginc.com

13 Jan 2015  
 RV58044-001

### Field Strength of Radiated Spurious

DNB Job Number:	RV58044-001	Date:	Dec 18 2014	<b>Specification</b> FCC 47 CFR 2.1053 15.109 87.139
Customer:	ACSS, an L-3 Communications & Thales Company			
Model Number:	NGT-9000	Serial Number:	N/A	
Description:	Diversity Mode-S Transponder			
Test Equipment: (See pg. 11)	Asset #'s: 11, 364, 1698, 2079, 2264			
EUT performed within the requirements of the applicable Standard(s) YES <input checked="" type="checkbox"/> NO <input type="checkbox"/> SIGNED Thomas Elders				

### Radiated Spurious Emissions XPDR Bottom Port 1GHz – 11GHz

Frequency (MHz)	Amplitude (dBμV)	Antenna (dB)	Preamp (dB)	Cable (dB)	Corrected (dBμV/m)	Polarity
2180	90	28	29	0.9	89.9	V
3270	72	31	29	1	75	V
4360	67	32	29	1.4	71.4	V
5450	60	34	29	1.5	66.5	V
6540	39	35	29	1.6	46.6	V
7630	39	37	29	1.7	48.7	V
8720	25	38	29	1.8	35.8	V
9810	22	38	29	1.9	32.9	V
10900	19	38	29	2	30	V
2180	70	28	29	0.9	69.9	H
3270	52	31	29	1	55	H
4360	56	32	29	1.4	60.4	H
5450	46	34	29	1.5	52.5	H
6540	37	35	29	1.6	44.6	H
7630	27	37	29	1.7	36.7	H
8720	22	38	29	1.8	32.8	H
9810	20	38	29	1.9	30.9	H
10900	20	38	29	2	31	H





5969 Robinson Ave  
 Riverside, CA 92503  
 (951) 637-2630  
 FAX (951) 637-2704  
 www.dnbenginc.com

13 Jan 2015  
 RV58044-001

### Frequency Stability

DNB Job Number:	RV58044-001	Date:	Dec 18 2014	<b>Specification</b> FCC 47 CFR 2.1053 15.109 87.139
Customer:	ACSS, an L-3 Communications & Thales Company			
Model Number:	NGT-9000	Serial Number:	N/A	
Description:	Diversity Mode-S Transponder			
Test Equipment: (See pg. 11)	Asset #'s: 11, 364, 1698, 2079, 2264			
EUT performed within the requirements of the applicable Standard(s) YES <input checked="" type="checkbox"/> NO <input type="checkbox"/> SIGNED Thomas Elders				

### Frequency Stability TAS (Temperature Variation)

Temperature (Degrees C)	Power Output (dBm)	Frequency (MHz)
-20	53.2	1030
-10	52.9	1030
0	52.8	1030
10	53	1030
20	52.7	1030
30	52.3	1030
40	52.5	1030
50	52.4	1030
55	52.5	1030

### Frequency Stability XPDR (Temperature Variation)

Temperature (Degrees C)	Top Port		Bottom Port	
	Power Output (dBm)	Frequency (MHz)	Power Output (dBm)	Frequency (MHz)
-20	52.9	1090	53	1090
-10	52.5	1090	52.6	1090
0	52.5	1090	52.6	1090
10	52.4	1090	52.7	1090
20	52.7	1090	52.9	1090
30	52.1	1090	52.2	1090
40	52.1	1090	52.4	1090
50	52.9	1090	52.3	1090
55	52.3	1090	52.5	1090



5969 Robinson Ave  
 Riverside, CA 92503  
 (951) 637-2630  
 FAX (951) 637-2704  
 www.dnbenginc.com

13 Jan 2015  
 RV58044-001

### Frequency Stability

DNB Job Number:	RV58044-001	Date:	Dec 18 2014	<b>Specification</b> FCC 47 CFR 2.1053 15.109 87.139
Customer:	ACSS, an L-3 Communications & Thales Company			
Model Number:	NGT-9000	Serial Number:	N/A	
Description:	Diversity Mode-S Transponder			
Test Equipment: (See pg. 11)	Asset #'s: 11, 364, 1698, 2079, 2264			
EUT performed within the requirements of the applicable Standard(s) YES <input checked="" type="checkbox"/> NO <input type="checkbox"/> SIGNED Thomas Elders				

### Frequency Stability TAS (Voltage Variation)

Supply Voltage (V)	Power Output (dBm)	Frequency (MHz)
11.9	52.6	1030
14	52.5	1030
16.1	52.7	1030
23.8	52.7	1030
28	52.8	1030
32.2	52.9	1030

### Frequency Stability XPDR (Voltage Variation)

Supply Voltage (V)	Top Port		Bottom Port	
	Power Output (dBm)	Frequency (MHz)	Power Output (dBm)	Frequency (MHz)
11.9	52.7	1090	53	1090
14	52.7	1090	53	1090
16.1	52.7	1090	53	1090
23.8	52.7	1090	53.1	1090
28	52.9	1090	53.1	1090
32.2	52.9	1090	52.2	1090



5969 Robinson Ave  
Riverside, CA 92503  
(951) 637-2630  
FAX (951) 637-2704  
[www.dnbenginc.com](http://www.dnbenginc.com)

13 Jan 2015  
RV58044-001

End of Report

Document Number 8020133-001	NGT-9000D FCC Test Procedures and Results	Revision -
--------------------------------	---	---------------

**END OF DOCUMENT**