Annex 4 to Test Report # EMCC-170187CC, 2020-02-05

DESCRIPTION OF EXCITER SETUP PROVIDED BY THE CUSTOMER

EQUIPMENT UNDER TEST:

Device:	BLA 350 Plus
Serial Number:	021019
Application:	Amplifier
FCC ID:	2ACTR-BLA350
Manufacturer:	RM Costruzioni Elettroniche srl
Address:	Via IV Novembre, 42 - Ponte della Venturina 40046 Alto Reno Terme (Bo) ITALY
Phone:	+39 0534 60-460
Fax:	-

RELEVANT STANDARD(S): 47 CFR §§ 97.307, 97.317

The following information was delivered by the customer:

BLA350 Plus Test Configuration.

Packing List:

2x BLA350 Plus Amplifier s/n: **021019** **011019**

Aluminium Test platform

Agilent N9310A Signal Generator

10dB Attenuator (Input to Exciter Amplifier)

EMPower 2005-BBS0A3FKO Exciter Power Amplifier

10 Low Pass Filters for Output of Exciter for:

160m (1.900 MHz Test Freq.)

80m (3.650 MHz Test Freq.)

40m (7.100 MHz Test Freq.)

30m (10.125 MHz Test Freq.)

20m (14.175 MHz Test Freq.)

17m (18.168 MHz Test Freq.)

15m (21.225 MHz Test Freq.)

12m (24.945 MHz Test Freq.)

10m (28.850 MHz Test Freq.)

1x coaxial cable RG142 52cm N-N Signal Generator O/P to 10dB Attenuator

1x coaxial cable RG142 52cm N-N Output of Exciter amplifier to input external LP Filter

1x coaxial cable RG223 95cm N-PL259 Filter O/P to Amplifier RTX Input

1x coaxial cable RG223 95cm N-PL259 Amplifier O/P ANT 1 to Dummy Load

1x manual PTT switch for Amplifier PTT input

4x N-SO239 & 4x PL259 to N Adaptor (If required)

1x spare coaxial cable RG223 N-PL259 95cm

Note:

It was understood that the power measurement instruments, directional coupler and dummy load / High Power attenuator will be provided by the test house. The typical set up is shown below in the photographs together with a simple block diagram.

Remark: According to customer's request, the test frequency 18.118 MHz instead of 18.168 MHz was used for testing.

Test of RM Costruzioni Elettroniche srl Amplifier BLA 350 PLUS to 47 CFR §§ 97.307, 97.317

Fig.1

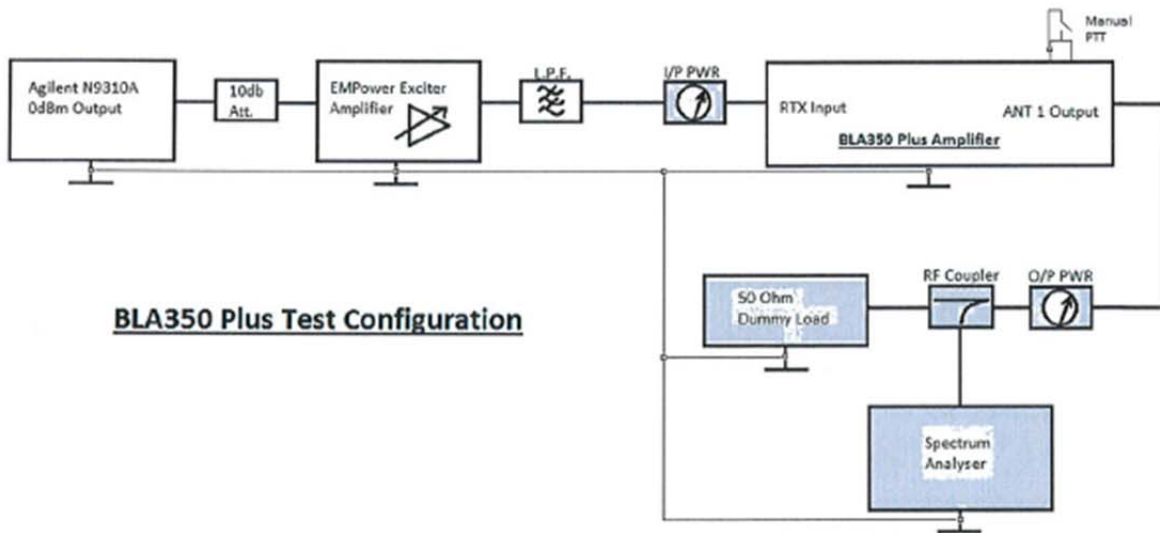

BLA350 Plus Test Configuration

Photo 1.



Front Panel Connections

Photo 2.

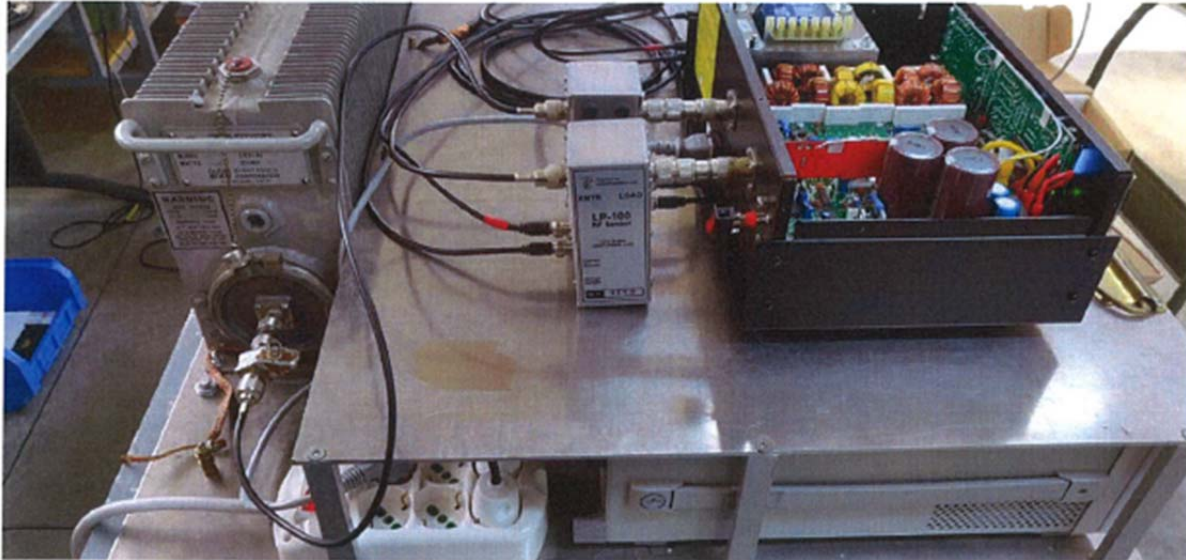

Rear Panel General view

Photo 3.

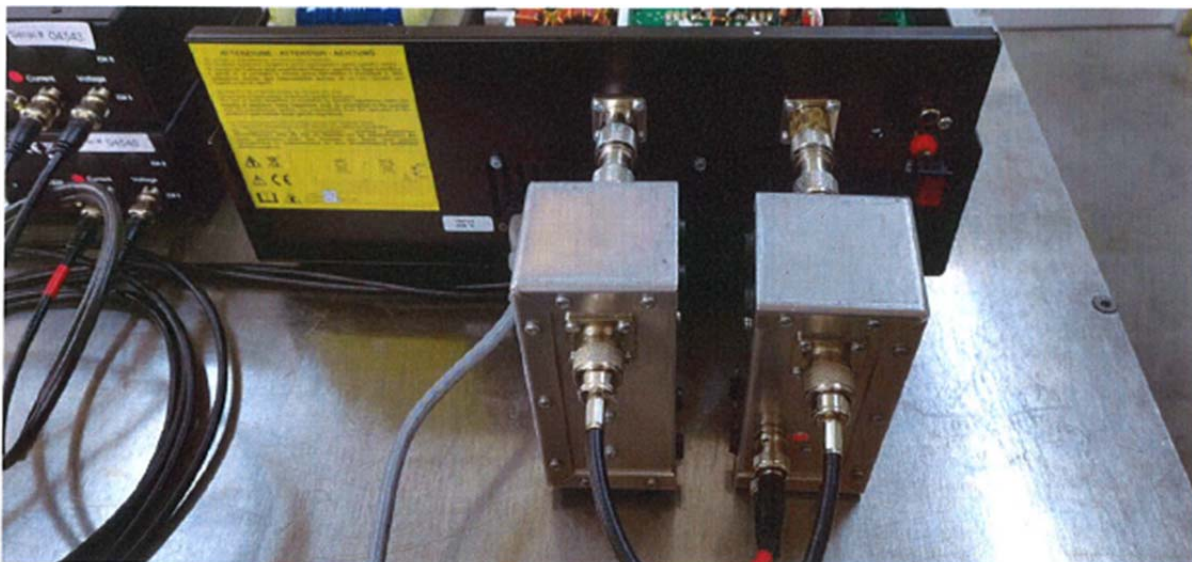

Output Power sensor Input Power sensor and manual PTT switch.

Photo 4.

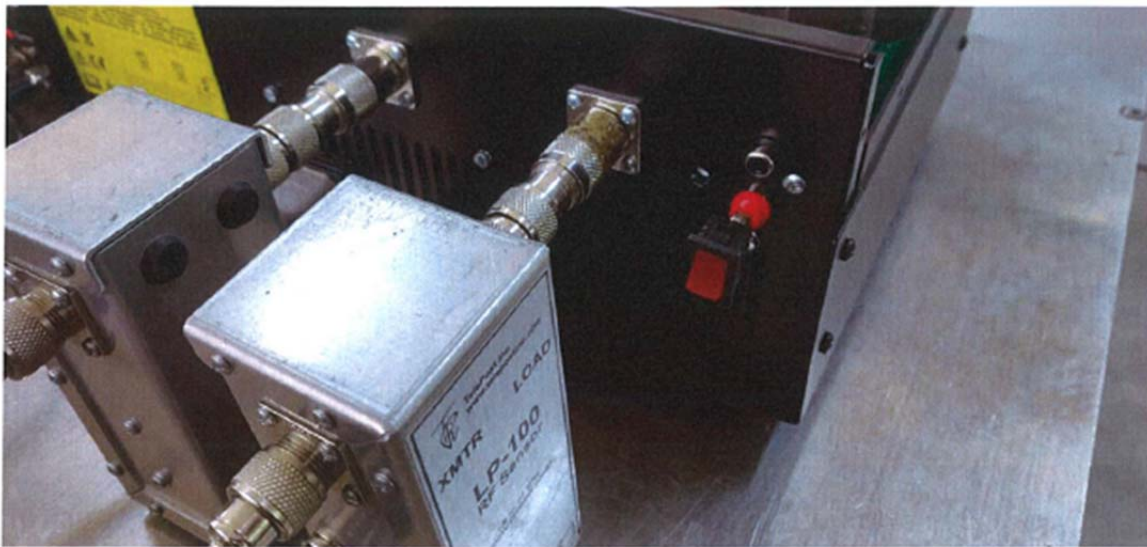

Manual PTT Switch

Photo 5.

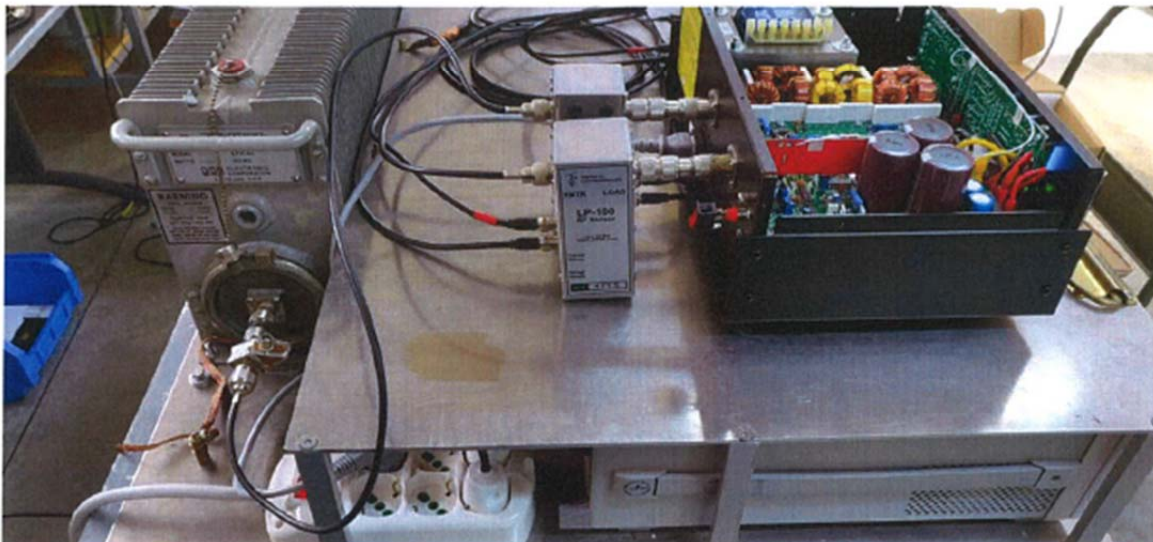

50 Ohm load and output coupler to Spectrum Analyser.

The Agilent N9310A signal generator set to 0dBm output, no modulation, at the chosen test frequency.

The Empower 2005-BBS0A3FKO should be set to minimum gain. It should also have a 10dB attenuator fitted to the input for protection against excessive input power. Connections are shown in Photo 1.

Depending on the test frequency the corresponding Low Pass Filter should be selected, they are all clearly labelled, one for each of the corresponding amateur radio bands, they have an IN and OUT port. IN connected to the output of the exciter amplifier and OUT connected to RTX input of the BLA350 amplifier under test.

Output exciter power is regulated by the gain adjustment on the front panel. All bands from 160m (1.900 MHz) to 10m (28.850MHz) require 10W input drive. Output power, (250W-300W), of the BLA350 amplifier under test is simply regulated by adjusting the gain of the exciter amplifier. The output of the signal generator should remain at 0dBm.

BLA350 amplifier under test should be connected as shown in the block diagram, Fig 1. RF Drive input from the output of the corresponding external low pass filter from the exciter amplifier to the RTX input of the BLA350. The output connector, ANT, for all bands. (50 Ohm impedance for all RF connections). Front panel switches should be set as following before powering on the amplifier. MAIN ON / OFF set to OFF, Stby / ON set to Stby, AUTO / MAN set to AUTO. The two central switches OK / SSB and SET are momentary action so do not need to be considered.

The amplifier requires a PTT input signal in order to amplify the signal so a manual PTT switch must be inserted into the PTT input on the BLA350 rear panel. See Photo 3. This needs to be manually operated in order for the BLA350 to work when in 'Operate' mode.

The amplifier under test (BLA350) should be switched 'ON' from the front panel 'MAIN' switch. A short self test ensues after which time the amplifier will be in 'Standby' condition. Amplifier filter selection can be left in Automatic mode or if the AUTO / MAN Switch is set to MAN the required filter may be selected by rotating the band selector control. In AUTO mode the physical position of the rotary control is not important. The correct filter will be automatically selected when there is RF on the RTX input connector, the PTT is activated on the rear panel and the Amplifier is in OPERATE mode.

To amplify the incoming signal the amplifier must first be switched to OPERATE mode by switching the Stby / ON button to ON. The PTT switch connected to the PTT input connector on the rear panel should then be operated to switch the amplifier to TX state. (At this point the signal generator should have its output disabled and the exciter amplifier should be already preset to give 10W at the test frequency, this may be carried out with the BLA350 Plus in Standby condition).

The amplifier will indicate it is in TX State by illuminating the 'TX' indicator on the front panel. The signal generator may now be switched on and the gain of the exciter amplifier adjusted if necessary to give 10W input drive. The amplifier can remain in TX for a reasonable amount of time in order to make power reading / spectrum plots however it is not a full duty cycle amplifier so should not be left in transmission at full output for long periods of time if not required. The signal

generator RF ON and OFF can be used to switch the power on and off, if required during tests done within the same band.

When a new frequency/band test is made the correct sequence is to switch the RF out off on the signal generator. Toggle the PTT switch on the rear panel of the BLA350 Plus test amplifier to return to Operate, (the front panel TX led extinguished). Press the STB / OPR button to return the amplifier to Standby. Return the gain of the exciter amplifier to zero.

The frequency of the Signal generator can now be changed along with changing to the appropriate Low Pass Filter for the output of the exciter amplifier. The BLA350 Plus test amplifier can also be switched to the new band of operation etc. And then the same procedure followed.

The user manual of the BLA350 amplifier has been included for any additional information required and for explanation of any error condition from incorrect operation.