

FCC Test Report

Report No.: RFBDQY-WTW-P22040472

FCC ID: 2ACTO-APX320X

Model: APX 320X

Received Date: Apr. 13, 2022

Test Date: May 12 ~ May 13, 2022

Issued Date: Oct. 19, 2022

Applicant: Sophos Ltd

Address: The Pentagon, Abingdon Science Park, Abingdon OX14 3YP, United Kingdom

Issued By: Bureau Veritas Consumer Products Services (H.K.) Ltd., Taoyuan Branch
Lin Kou Laboratories

Lab Address: No. 47-2, 14th Ling, Chia Pau Vil., Lin Kou Dist., New Taipei City, Taiwan

Test Location: No. 19, Hwa Ya 2nd Rd., Wen Hwa Vil., Kwei Shan Dist., Taoyuan City
33383, Taiwan

**FCC Registration /
Designation Number:** 788550 / TW0003



This report is governed by, and incorporates by reference, the Conditions of Testing as posted at the date of issuance of this report at <http://www.bureauveritas.com/home/about-us/our-business/cps/about-us/terms-conditions/> and is intended for your exclusive use. Any copying or replication of this report to or for any other person or entity, or use of our name or trademark, is permitted only with our prior written permission. This report sets forth our findings solely with respect to the test samples identified herein. The results set forth in this report are not indicative or representative of the quality or characteristics of the lot from which a test sample was taken or any similar or identical product unless specifically and expressly noted. Our report includes all of the tests requested by you and the results thereof based upon the information that you provided to us. Measurement uncertainty is only provided upon request for accredited tests. Statements of conformity are based on simple acceptance criteria without taking measurement uncertainty into account, unless otherwise requested in writing. You have 60 days from date of issuance of this report to notify us of any material error or omission caused by our negligence or if you require measurement uncertainty; provided, however, that such notice shall be in writing and shall specifically address the issue you wish to raise. A failure to raise such issue within the prescribed time shall constitute your unqualified acceptance of the completeness of this report, the tests conducted and the correctness of the report contents.

Table of Contents

Release Control Record	3
1 Certificate of Conformity	4
2 Summary of Test Results	5
2.1 Measurement Uncertainty.....	5
2.2 Modification Record.....	5
3 General Information	6
3.1 General Description of EUT.....	6
3.2 Description of Test Modes.....	7
3.2.1 Test Mode Applicability and Tested Channel Detail.....	8
3.3 Description of Support Units.....	9
3.3.1 Configuration of System under Test.....	9
3.4 General Description of Applied Standards and References.....	10
4 Test Types and Results	11
4.1 Radiated Emission and Bandedge Measurement.....	11
4.1.1 Limits of Radiated Emission and Bandedge Measurement.....	11
4.1.2 Test Instruments.....	12
4.1.3 Test Procedures.....	13
4.1.4 Deviation from Test Standard.....	13
4.1.5 Test Set Up.....	14
4.1.6 EUT Operating Conditions.....	14
4.1.7 Test Results.....	15
4.2 Conducted Emission Measurement.....	21
4.2.1 Limits of Conducted Emission Measurement.....	21
4.2.2 Test Instruments.....	21
4.2.3 Test Procedures.....	22
4.2.4 Deviation from Test Standard.....	22
4.2.5 Test Setup.....	22
4.2.6 EUT Operating Conditions.....	22
4.2.7 Test Results.....	23
5 Pictures of Test Arrangements	29
Appendix – Information of the Testing Laboratories	30



Release Control Record

Issue No.	Description	Date Issued
RFBDQY-WTW-P22040472	Original release	Oct. 19, 2022

1 Certificate of Conformity

Product: Sophos Access Point

Brand: Sophos

Model: APX 320X

Sample Status: Engineering sample

Applicant: Sophos Ltd

Test Date: May 12 ~ May 13, 2022

Standards: 47 CFR FCC Part 15, Subpart C (Section 15.247)
ANSI C63.10:2013

This report is issued as a supplementary report of RF191104C18-1. This report shall be used combined together with its original report.

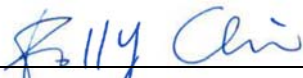
Prepared by :  , **Date:** Oct. 19, 2022
Polly Chien / Specialist

Approved by :  , **Date:** Oct. 19, 2022
Jeremy Lin / Project Engineer

Note: Radiated emission below 1GHz and conducted emission are performed for the addendum. Refer to original report for the other test data.

2 Summary of Test Results

47 CFR FCC Part 15, Subpart C (Section 15.247)			
FCC Clause	Test Item	Result	Remarks
15.207	AC Power Conducted Emission	Pass	Meet the requirement of limit. Minimum passing margin is -1.50dB at 15.02755MHz
15.205 / 15.209 / 15.247(d)	Radiated Emissions and Band Edge Measurement	Pass	Meet the requirement of limit. Minimum passing margin is -2.0dB at 32.59MHz.
15.247(d)	Antenna Port Emission	N/A	Refer to Note 1
15.247(a)(2)	6dB bandwidth	N/A	Refer to Note 1
15.247(b)	Conducted power	N/A	Refer to Note 1
15.247(e)	Power Spectral Density	N/A	Refer to Note 1
15.203	Antenna Requirement	Pass	Antenna connector is N-Type connector not a standard connector.

Note:

1. Radiated emission below 1GHz and conducted emission are performed for the addendum. Refer to original report for the other test data.
2. Determining compliance based on the results of the compliance measurement, not taking into account measurement instrumentation uncertainty.

2.1 Measurement Uncertainty

Where relevant, the following measurement uncertainty levels have been estimated for tests performed on the EUT as specified in CISPR 16-4-2:

Measurement	Frequency	Expanded Uncertainty (k=2) (\pm)
Conducted Emissions at mains ports	150kHz ~ 30MHz	2.79 dB
Radiated Emissions up to 1 GHz	9kHz ~ 30MHz	3.04 dB
	30MHz ~ 200MHz	3.59 dB
	200MHz ~ 1000MHz	3.60 dB

2.2 Modification Record

There were no modifications required for compliance.

3 General Information

3.1 General Description of EUT

Product	Sophos Access Point			
Brand	Sophos			
Model	APX 320X			
Sample Status	Engineering sample			
Power Supply Rating	55Vdc (PoE)			
Modulation Type	CCK, DQPSK, DBPSK for DSSS 64QAM, 16QAM, QPSK, BPSK for OFDM			
Modulation Technology	DSSS, OFDM			
Transfer Rate	802.11b: 11.0/ 5.5/ 2.0/ 1.0Mbps 802.11g: 54.0/ 48.0/ 36.0/ 24.0/ 18.0/ 12.0/ 9.0/ 6.0Mbps 802.11n: up to 300Mbps			
Operating Frequency	2412 ~ 2462MHz			
Number of Channel	11 for 802.11b, 802.11g, 802.11n (HT20) 7 for 802.11n (HT40)			
Output Power		Dipole antenna	Directional antenna	Sector antenna
	CDD Mode	576.047mW	249.141mW	249.141mW
	Beamforming Mode	447.495mW	124.867mW	124.867mW
Antenna Type	Refer to note			
Antenna Connector	Refer to note			
Accessory Device	NA			
Data Cable Supplied	NA			

Note:

1. This report is prepared for FCC class II permissive change. The difference compared with the original report no. RF191104C18-1 is removing TPM IC. Therefore, radiated emission below 1GHz and conducted emission are performed for the addendum. Refer to original report for the other test data.
2. The EUT incorporates a MIMO function. Physically, the EUT provides 2 completed transmitters and 2 receivers.

2.4GHz Band		
Modulation Mode	TX Function	Beamforming
802.11b	2TX	Not Support
802.11g	2TX	Not Support
802.11n (HT20)	2TX	Support
802.11n (HT40)	2TX	Support

3. The EUT uses the following PoE. (Support unit only)

Brand	Microsemi
Model	PD-9001GR/AC
Input Power	100-240Vac~50/60Hz, 0.67A
Output Power	55Vdc / 0.6A

4. The EUT uses the following antennas.

NO.	Type	Gain(dBi)								Connector
		2400 MHz	2450 MHz	2500 MHz	5150 MHz	5325 MHz	5500 MHz	5675 MHz	5850 MHz	
1	Dipole	3.1	3.2	3.1	5.1	5.0	5.6	5.7	6.0	N type
2	Directional	11.6	12.0	11.9	10.55	11.2	11.5	11.2	11.5	N type
3	Sector	10.6	11.4	11.2	12.57	12.7	13.0	12.4	13.1	N type

* Detail antenna specification please refer to antenna datasheet and/or antenna measurement report.

3.2 Description of Test Modes

11 channels are provided for 802.11b, 802.11g and 802.11n (HT20):

Channel	Frequency	Channel	Frequency
1	2412MHz	7	2442MHz
2	2417MHz	8	2447MHz
3	2422MHz	9	2452MHz
4	2427MHz	10	2457MHz
5	2432MHz	11	2462MHz
6	2437MHz		

7 channels are provided for 802.11n (HT40):

Channel	Frequency	Channel	Frequency
3	2422MHz	7	2442MHz
4	2427MHz	8	2447MHz
5	2432MHz	9	2452MHz
6	2437MHz		

3.2.1 Test Mode Applicability and Tested Channel Detail

EUT CONFIGURE MODE	APPLICABLE TO		DESCRIPTION
	RE<1G	PLC	
A	√	√	EUT with Dipole antenna
B	√	√	EUT with Directional antenna
C	√	√	EUT with Sector antenna

Where **RE<1G**: Radiated Emission below 1GHz **PLC**: Power Line Conducted Emission

Note:

1. The EUT had been pre-tested on the positioned of each 3 axis. The worst case was found when positioned on **Z-plane**.
2. For radiated emission (below 1GHz) and power line conducted emission test items, the worst maximum power was selected.

Radiated Emission Test (Below 1GHz):

- Pre-Scan has been conducted to determine the worst-case mode from all possible combinations between available modulations, data rates and antenna ports (if EUT with antenna diversity architecture).
- Following channel(s) was (were) selected for the final test as listed below.

EUT CONFIGURE MODE	MODE	AVAILABLE CHANNEL	TESTED CHANNEL	MODULATION TECHNOLOGY	MODULATION TYPE	DATA RATE (Mbps)
A, B, C	802.11b	1 to 11	6	DSSS	DBPSK	1.0

Power Line Conducted Emission Test:

- Pre-Scan has been conducted to determine the worst-case mode from all possible combinations between available modulations, data rates and antenna ports (if EUT with antenna diversity architecture).
- Following channel(s) was (were) selected for the final test as listed below.

EUT CONFIGURE MODE	MODE	AVAILABLE CHANNEL	TESTED CHANNEL	MODULATION TECHNOLOGY	MODULATION TYPE	DATA RATE (Mbps)
A, B, C	802.11b	1 to 11	6	DSSS	DBPSK	1.0

Test Condition:

APPLICABLE TO	ENVIRONMENTAL CONDITIONS	INPUT POWER (SYSTEM)	TESTED BY
RE<1G	23deg. C, 68%RH	120Vac, 60Hz	Adair Peng
PLC	25deg. C, 75%RH	120Vac, 60Hz	Rex Wang

3.3 Description of Support Units

The EUT has been tested as an independent unit together with other necessary accessories or support units. The following support units or accessories were used to form a representative test configuration during the tests.

ID	Product	Brand	Model No.	Serial No.	FCC ID	Remarks
A.	Notebook	Lenovo	80Q7	PF0KUGU6	NA	-
B.	PoE	Microsemi	PD-9001GR/AC	NA	NA	-

Note: All power cords of the above support units are non-shielded (1.8m).

ID	Descriptions	Qty.	Length (m)	Shielding (Yes/No)	Cores (Qty.)	Remarks
1.	RJ45 cable	1	2	N	0	-
2.	RJ45 cable	1	10	N	0	-

3.3.1 Configuration of System under Test

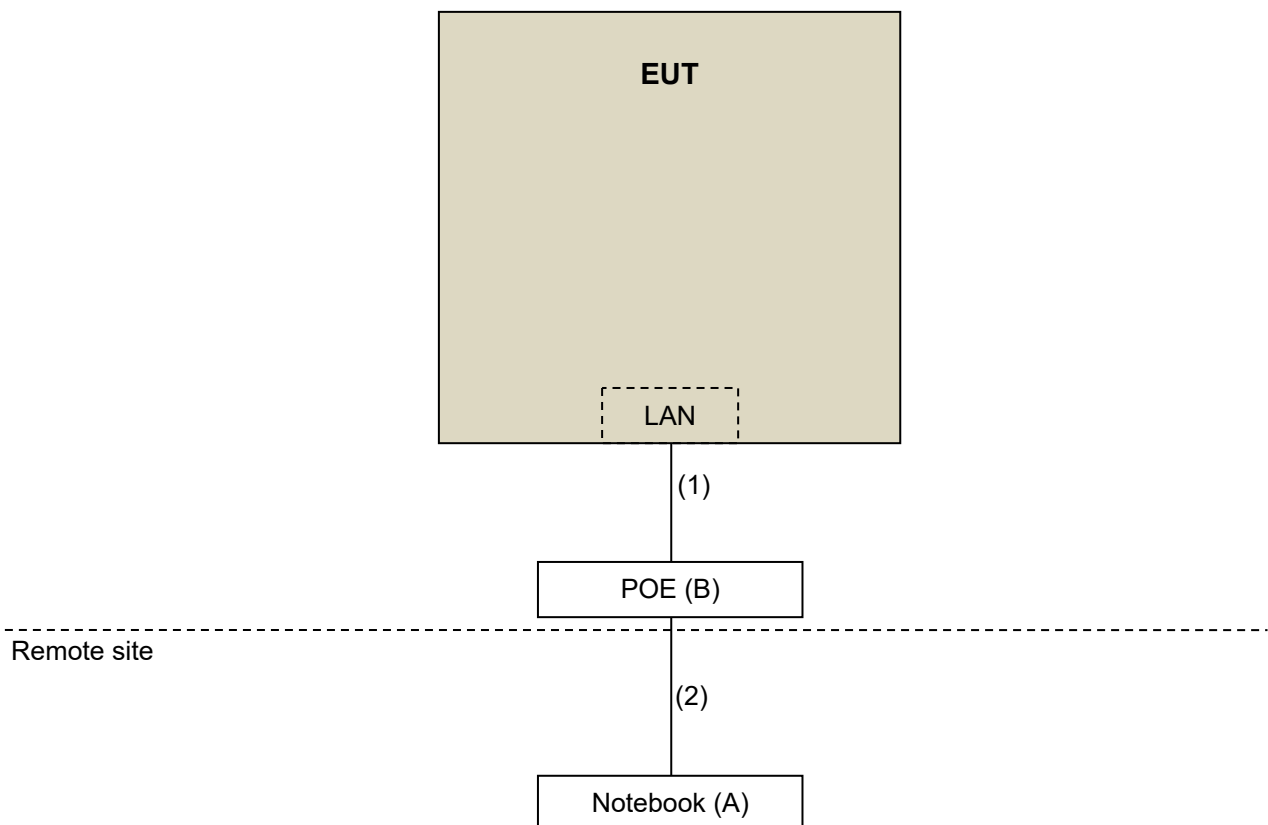

3.4 General Description of Applied Standards and References

The EUT is a RF Product. According to the specifications of the manufacturer, it must comply with the requirements of the following standards and References:

Test Standard:

FCC Part 15, Subpart C (15.247)

ANSI C63.10-2013

All test items have been performed and recorded as per the above standards.

References Test Guidance:

KDB 558074 D01 DTS Meas Guidance v05r02

KDB 662911 D01 Multiple Transmitter Output v02r01

All test items have been performed as a reference to the above KDB test guidance.

4 Test Types and Results

4.1 Radiated Emission and Bandedge Measurement

4.1.1 Limits of Radiated Emission and Bandedge Measurement

Radiated emissions which fall in the restricted bands must comply with the radiated emission limits specified as below table. Other emissions shall be at least 30dB below the highest level of the desired power:

Frequencies (MHz)	Field Strength (microvolts/meter)	Measurement Distance (meters)
0.009 ~ 0.490	2400/F(kHz)	300
0.490 ~ 1.705	24000/F(kHz)	30
1.705 ~ 30.0	30	30
30 ~ 88	100	3
88 ~ 216	150	3
216 ~ 960	200	3
Above 960	500	3

Note:

1. The lower limit shall apply at the transition frequencies.
2. Emission level (dBuV/m) = 20 log Emission level (uV/m).
3. For frequencies above 1000MHz, the field strength limits are based on average detector, however, the peak field strength of any emission shall not exceed the maximum permitted average limits, specified above by more than 30dB under any condition of modulation.

4.1.2 Test Instruments

Description & Manufacturer	Model No.	Serial No.	Cal. Date	Cal. Due
Test Receiver KEYSIGHT	N9038A	MY55420137	Apr. 27, 2022	Apr. 26, 2023
Spectrum Analyzer ROHDE & SCHWARZ	FSP40	100039	Jun. 10, 2021	Jun. 09, 2022
BILOG Antenna SCHWARZBECK	VULB9168	9168-160	Oct. 28, 2021	Oct. 27, 2022
Loop Antenna TESEQ	HLA 6121	45745	Jul. 21, 2021	Jul. 20, 2022
Preamplifier Agilent (Below 1GHz)	8447D	2944A10638	Jun. 05, 2021	Jun. 04, 2022
RF signal cable Woken	8D-FB	Cable-CH9-01	Jun. 05, 2021	Jun. 04, 2022
Software BV ADT	ADT_Radiated_ V7.6.15.9.5	NA	NA	NA
Antenna Tower & Turn BV ADT	AT100	AT93021705	NA	NA
Turn Table BV ADT	TT100	TT93021705	NA	NA
Turn Table Controller BV ADT	SC100	SC93021705	NA	NA
Boresight Antenna Fixture	FBA-01	FBA-SIP01	NA	NA

- Note: 1. The calibration interval of the above test instruments is 12 months and the calibrations are traceable to NML/ROC and NIST/USA.
 2. The test was performed in HwaYa Chamber 9.
 3. Tested date: May 12, 2022

4.1.3 Test Procedures

For Radiated emission below 30MHz

- a. The EUT was placed on the top of a rotating table 0.8 meters above the ground at a 3 meter chamber room. The table was rotated 360 degrees to determine the position of the highest radiation.
- b. The EUT was set 3 meters away from the interference-receiving antenna, which was mounted on the top of a variable-height antenna tower.
- c. Parallel, perpendicular, and ground-parallel orientations of the antenna are set to make the measurement.
- d. For each suspected emission, the EUT was arranged to its worst case and the rotatable table was turned from 0 degrees to 360 degrees to find the maximum reading.
- e. The test-receiver system was set to Quasi-Peak Detect Function and Specified Bandwidth with Maximum Hold Mode.

NOTE:

1. The resolution bandwidth and video bandwidth of test receiver/spectrum analyzer is 9kHz at frequency below 30MHz.

For Radiated emission above 30MHz

- a. The EUT was placed on the top of a rotating table 0.8 meters above the ground at 3 meter chamber room for test. The table was rotated 360 degrees to determine the position of the highest radiation.
- b. The EUT was set 3 meters away from the interference-receiving antenna, which was mounted on the top of a variable-height antenna tower.
- c. The height of antenna is varied from one meter to four meters above the ground to determine the maximum value of the field strength. Both horizontal and vertical polarizations of the antenna are set to make the measurement.
- d. For each suspected emission, the EUT was arranged to its worst case and then the antenna was tuned to heights from 1 meter to 4 meters and the rotatable table was turned from 0 degrees to 360 degrees to find the maximum reading.
- e. The test-receiver system was set to quasi-peak detect function and specified bandwidth with maximum hold mode when the test frequency is below 1 GHz.

Note:

1. The resolution bandwidth and video bandwidth of test receiver/spectrum analyzer is 120kHz for Quasi-peak detection (QP) at frequency below 1GHz.
2. All modes of operation were investigated and the worst-case emissions are reported.

4.1.4 Deviation from Test Standard

No deviation.

4.1.5 Test Set Up

For Radiated emission below 30MHz

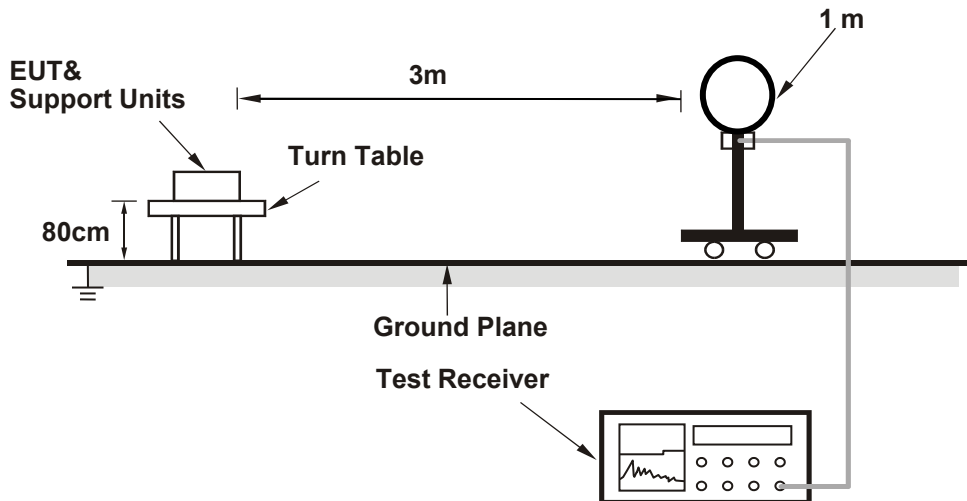

For Radiated emission 30MHz to 1GHz

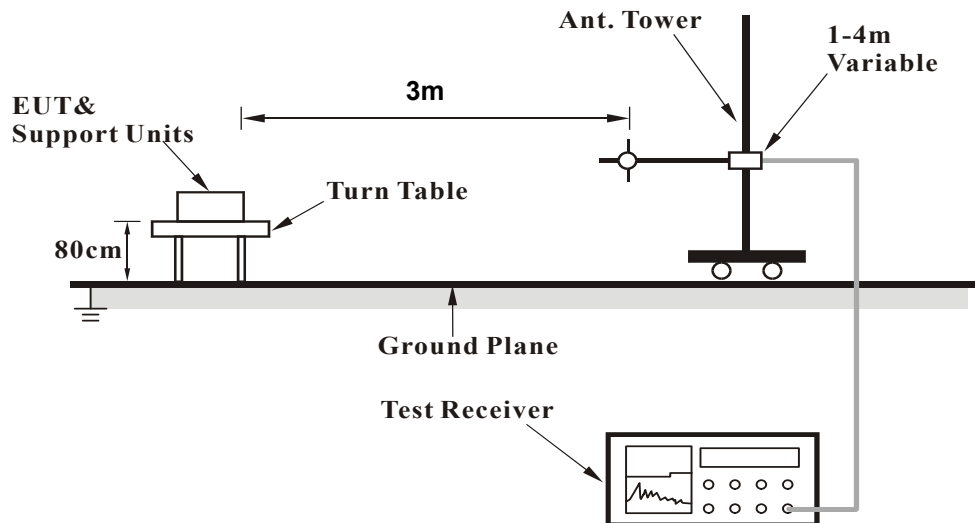

For the actual test configuration, please refer to the attached file (Test Setup Photo).

4.1.6 EUT Operating Conditions

- Placed the EUT on the testing table.
- Prepared a notebook to act as a communication partner and placed it outside of testing area.
- The communication partner connected with EUT via a RJ45 cable and ran a test program (QRCT3) to enable EUT under transmission condition continuously at specific channel frequency.
- The communication partner sent data to EUT by command "PING".

4.1.7 Test Results

Below 1GHz worst-case data:

Test Mode A

802.11b

CHANNEL	TX Channel 6	DETECTOR FUNCTION	Quasi-Peak (QP)
FREQUENCY RANGE	9kHz ~ 1GHz		

ANTENNA POLARITY & TEST DISTANCE: HORIZONTAL AT 3 M								
NO.	FREQ. (MHz)	EMISSION LEVEL (dBuV/m)	LIMIT (dBuV/m)	MARGIN (dB)	ANTENNA HEIGHT (m)	TABLE ANGLE (Degree)	RAW VALUE (dBuV)	CORRECTION FACTOR (dB/m)
1	34.85	33.3 QP	40.0	-6.7	1.99 H	150	43.4	-10.1
2	97.90	39.6 QP	43.5	-3.9	1.00 H	131	53.7	-14.1
3	135.73	39.4 QP	43.5	-4.1	1.99 H	5	49.1	-9.7
4	200.72	38.6 QP	43.5	-4.9	1.00 H	142	50.1	-11.5
5	231.76	37.3 QP	46.0	-8.7	1.00 H	112	47.8	-10.5
6	678.93	30.4 QP	46.0	-15.6	1.00 H	9	29.8	0.6

Remarks:

1. Emission Level(dBuV/m) = Raw Value(dBuV) + Correction Factor(dB/m)
2. Correction Factor(dB/m) = Antenna Factor(dB/m) + Cable Factor(dB)
3. The other emission levels were very low against the limit.
4. Margin value = Emission Level – Limit value
5. The emission levels were very low against the limit of frequency range 9kHz~30MHz: the amplitude of spurious emissions attenuated more than 20dB below the permissible value to be report.

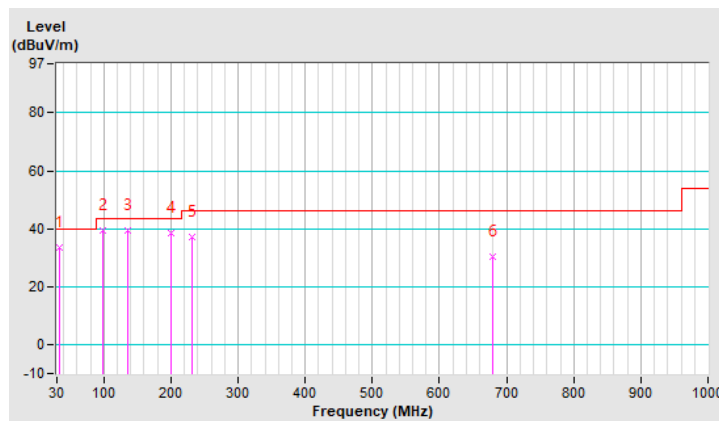

CHANNEL	TX Channel 6	DETECTOR FUNCTION	Quasi-Peak (QP)
FREQUENCY RANGE	9kHz ~ 1GHz		

ANTENNA POLARITY & TEST DISTANCE: VERTICAL AT 3 M								
NO.	FREQ. (MHz)	EMISSION LEVEL (dBuV/m)	LIMIT (dBuV/m)	MARGIN (dB)	ANTENNA HEIGHT (m)	TABLE ANGLE (Degree)	RAW VALUE (dBuV)	CORRECTION FACTOR (dB/m)
1	32.59	38.0 QP	40.0	-2.0	2.00 V	16	48.3	-10.3
2	55.02	33.9 QP	40.0	-6.1	1.00 V	21	43.1	-9.2
3	80.06	21.2 QP	40.0	-18.8	1.00 V	21	34.7	-13.5
4	135.73	39.8 QP	43.5	-3.7	1.99 V	5	49.5	-9.7
5	297.72	36.2 QP	46.0	-9.8	1.00 V	19	43.2	-7.0
6	465.53	38.2 QP	46.0	-7.8	1.00 V	19	41.4	-3.2

Remarks:

1. Emission Level(dBuV/m) = Raw Value(dBuV) + Correction Factor(dB/m)
2. Correction Factor(dB/m) = Antenna Factor(dB/m) + Cable Factor(dB)
3. The other emission levels were very low against the limit.
4. Margin value = Emission Level – Limit value
5. The emission levels were very low against the limit of frequency range 9kHz~30MHz: the amplitude of spurious emissions attenuated more than 20dB below the permissible value to be report.

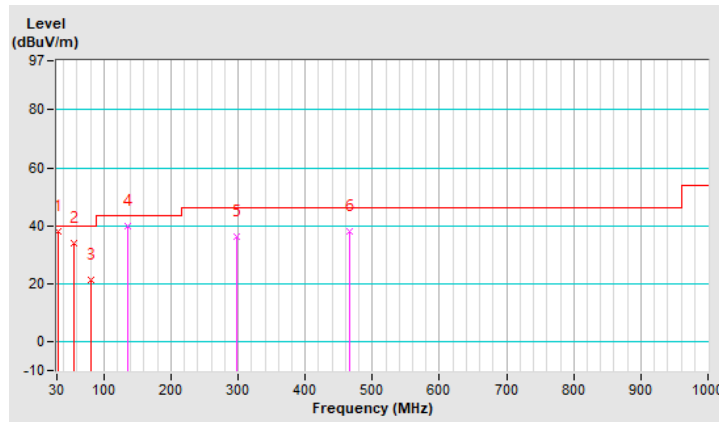

Test Mode B

802.11b

CHANNEL	TX Channel 6	DETECTOR FUNCTION	Quasi-Peak (QP)
FREQUENCY RANGE	9kHz ~ 1GHz		

ANTENNA POLARITY & TEST DISTANCE: HORIZONTAL AT 3 M								
NO.	FREQ. (MHz)	EMISSION LEVEL (dBuV/m)	LIMIT (dBuV/m)	MARGIN (dB)	ANTENNA HEIGHT (m)	TABLE ANGLE (Degree)	RAW VALUE (dBuV)	CORRECTION FACTOR (dB/m)
1	35.82	35.2 QP	40.0	-4.8	1.50 H	71	45.5	-10.3
2	69.77	30.6 QP	40.0	-9.4	1.00 H	164	41.6	-11.0
3	97.90	25.4 QP	43.5	-18.1	1.00 H	217	39.5	-14.1
4	250.19	24.2 QP	46.0	-21.8	1.50 H	105	33.1	-8.9
5	341.37	23.2 QP	46.0	-22.8	1.00 H	58	29.3	-6.1
6	370.47	26.5 QP	46.0	-19.5	1.00 H	12	32.1	-5.6

Remarks:

1. Emission Level(dBuV/m) = Raw Value(dBuV) + Correction Factor(dB/m)
2. Correction Factor(dB/m) = Antenna Factor(dB/m) + Cable Factor(dB)
3. The other emission levels were very low against the limit.
4. Margin value = Emission Level – Limit value
5. The emission levels were very low against the limit of frequency range 9kHz~30MHz: the amplitude of spurious emissions attenuated more than 20dB below the permissible value to be report.

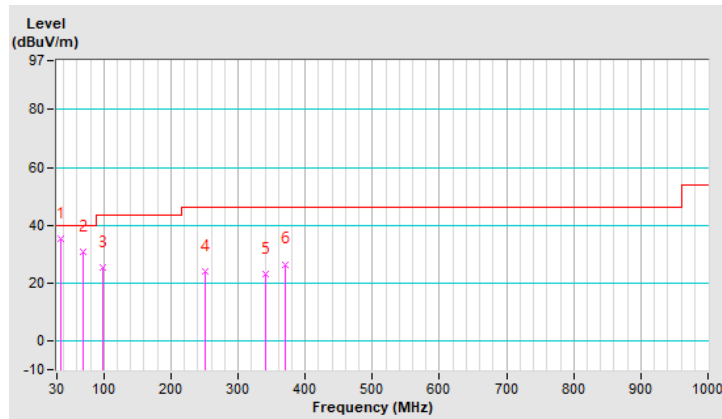

CHANNEL	TX Channel 6	DETECTOR FUNCTION	Quasi-Peak (QP)
FREQUENCY RANGE	9kHz ~ 1GHz		

ANTENNA POLARITY & TEST DISTANCE: VERTICAL AT 3 M								
NO.	FREQ. (MHz)	EMISSION LEVEL (dBuV/m)	LIMIT (dBuV/m)	MARGIN (dB)	ANTENNA HEIGHT (m)	TABLE ANGLE (Degree)	RAW VALUE (dBuV)	CORRECTION FACTOR (dB/m)
1	30.00	32.4 QP	40.0	-7.6	1.50 V	6	42.6	-10.2
2	37.76	29.8 QP	40.0	-10.2	1.50 V	6	39.5	-9.7
3	95.96	28.0 QP	43.5	-15.5	1.00 V	6	42.7	-14.7
4	133.79	31.5 QP	43.5	-12.0	1.00 V	90	41.3	-9.8
5	165.80	31.1 QP	43.5	-12.4	1.00 V	90	39.9	-8.8
6	515.00	28.4 QP	46.0	-17.6	2.00 V	123	30.6	-2.2

Remarks:

1. Emission Level(dBuV/m) = Raw Value(dBuV) + Correction Factor(dB/m)
2. Correction Factor(dB/m) = Antenna Factor(dB/m) + Cable Factor(dB)
3. The other emission levels were very low against the limit.
4. Margin value = Emission Level – Limit value
5. The emission levels were very low against the limit of frequency range 9kHz~30MHz: the amplitude of spurious emissions attenuated more than 20dB below the permissible value to be report.

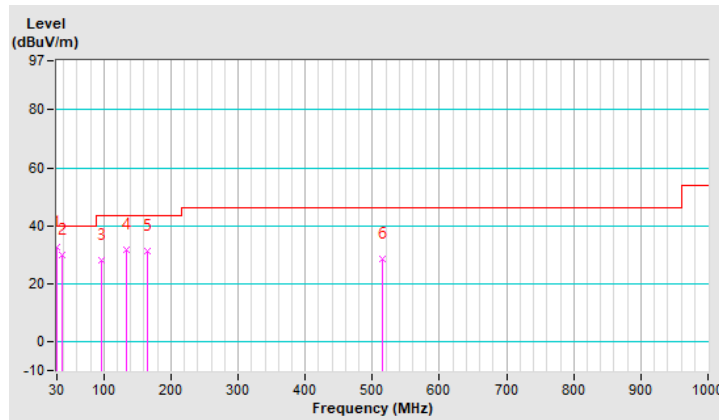

Test Mode C

802.11b

CHANNEL	TX Channel 6	DETECTOR FUNCTION	Quasi-Peak (QP)
FREQUENCY RANGE	9kHz ~ 1GHz		

ANTENNA POLARITY & TEST DISTANCE: HORIZONTAL AT 3 M								
NO.	FREQ. (MHz)	EMISSION LEVEL (dBuV/m)	LIMIT (dBuV/m)	MARGIN (dB)	ANTENNA HEIGHT (m)	TABLE ANGLE (Degree)	RAW VALUE (dBuV)	CORRECTION FACTOR (dB/m)
1	36.79	34.6 QP	40.0	-5.4	1.00 H	343	44.7	-10.1
2	50.37	33.6 QP	40.0	-6.4	1.00 H	302	42.6	-9.0
3	95.96	34.2 QP	43.5	-9.3	1.50 H	129	48.9	-14.7
4	152.22	32.8 QP	43.5	-10.7	1.00 H	222	41.7	-8.9
5	433.52	31.6 QP	46.0	-14.4	2.00 H	2	35.4	-3.8
6	654.68	30.0 QP	46.0	-16.0	1.00 H	272	29.8	0.2

Remarks:

1. Emission Level(dBuV/m) = Raw Value(dBuV) + Correction Factor(dB/m)
2. Correction Factor(dB/m) = Antenna Factor(dB/m) + Cable Factor(dB)
3. The other emission levels were very low against the limit.
4. Margin value = Emission Level – Limit value
5. The emission levels were very low against the limit of frequency range 9kHz~30MHz: the amplitude of spurious emissions attenuated more than 20dB below the permissible value to be report.

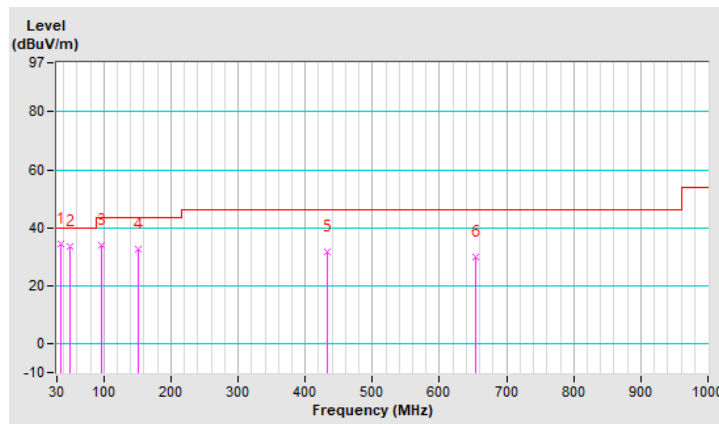

CHANNEL	TX Channel 6	DETECTOR FUNCTION	Quasi-Peak (QP)
FREQUENCY RANGE	9kHz ~ 1GHz		

ANTENNA POLARITY & TEST DISTANCE: VERTICAL AT 3 M								
NO.	FREQ. (MHz)	EMISSION LEVEL (dBuV/m)	LIMIT (dBuV/m)	MARGIN (dB)	ANTENNA HEIGHT (m)	TABLE ANGLE (Degree)	RAW VALUE (dBuV)	CORRECTION FACTOR (dB/m)
1	36.79	37.2 QP	40.0	-2.8	1.50 V	333	47.3	-10.1
2	68.80	31.4 QP	40.0	-8.6	1.00 V	137	42.4	-11.0
3	97.90	28.2 QP	43.5	-15.3	1.50 V	235	42.3	-14.1
4	250.19	23.6 QP	46.0	-22.4	2.00 V	76	32.5	-8.9
5	438.37	33.5 QP	46.0	-12.5	1.00 V	9	37.1	-3.6
6	579.99	29.6 QP	46.0	-16.4	1.00 V	227	30.4	-0.8

Remarks:

1. Emission Level(dBuV/m) = Raw Value(dBuV) + Correction Factor(dB/m)
2. Correction Factor(dB/m) = Antenna Factor(dB/m) + Cable Factor(dB)
3. The other emission levels were very low against the limit.
4. Margin value = Emission Level – Limit value
5. The emission levels were very low against the limit of frequency range 9kHz~30MHz: the amplitude of spurious emissions attenuated more than 20dB below the permissible value to be report.

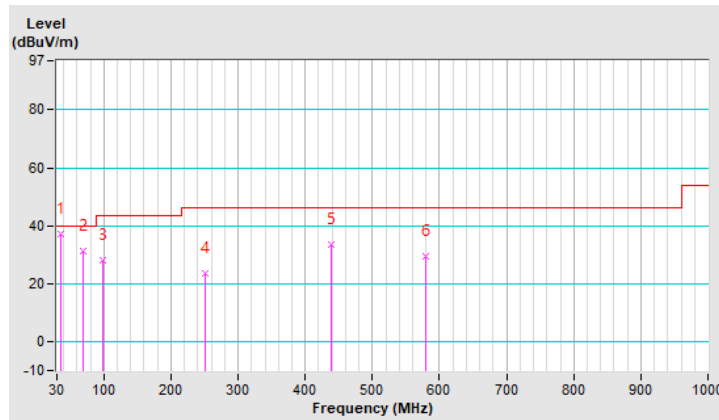

4.2 Conducted Emission Measurement

4.2.1 Limits of Conducted Emission Measurement

Frequency (MHz)	Conducted Limit (dBuV)	
	Quasi-peak	Average
0.15 - 0.5	66 - 56	56 - 46
0.50 - 5.0	56	46
5.0 - 30.0	60	50

- Note:** 1. The lower limit shall apply at the transition frequencies.
 2. The limit decreases in line with the logarithm of the frequency in the range of 0.15 to 0.50MHz.

4.2.2 Test Instruments

Description & Manufacturer	Model No.	Serial No.	Cal. Date	Cal. Due
Test Receiver ROHDE & SCHWARZ	ESCI	100613	Dec. 03, 2021	Dec. 02, 2022
RF signal cable (with 10dB PAD) Woken	5D-FB	Cable-cond1-01	Jan. 15, 2022	Jan. 14, 2023
LISN ROHDE & SCHWARZ (EUT)	ENV216	101826	Mar. 14, 2022	Mar. 13, 2023
LISN ROHDE & SCHWARZ (Peripheral)	ESH3-Z5	100311	Sep. 07, 2021	Sep. 06, 2022
Software ADT	BV ADT_Cond_ V7.3.7.4	NA	NA	NA

- Note:** 1. The calibration interval of the above test instruments is 12 months and the calibrations are traceable to NML/ROC and NIST/USA.
 2. The test was performed in HwaYa Shielded Room 1 (Conduction 1).
 3. The VCCI Site Registration No. is C-12040.
 4. Test Date: May 13, 2022

4.2.3 Test Procedures

- The EUT was placed 0.4 meters from the conducting wall of the shielded room with EUT being connected to the power mains through a line impedance stabilization network (LISN). Other support units were connected to the power mains through another LISN. The two LISNs provide 50 ohm/ 50uH of coupling impedance for the measuring instrument.
- Both lines of the power mains connected to the EUT were checked for maximum conducted interference.
- The frequency range from 150kHz to 30MHz was searched. Emission levels under (Limit - 20dB) was not recorded.

Note: The resolution bandwidth and video bandwidth of test receiver is 9kHz for quasi-peak detection (QP) and average detection (AV) at frequency 0.15MHz-30MHz.

4.2.4 Deviation from Test Standard

No deviation.

4.2.5 Test Setup

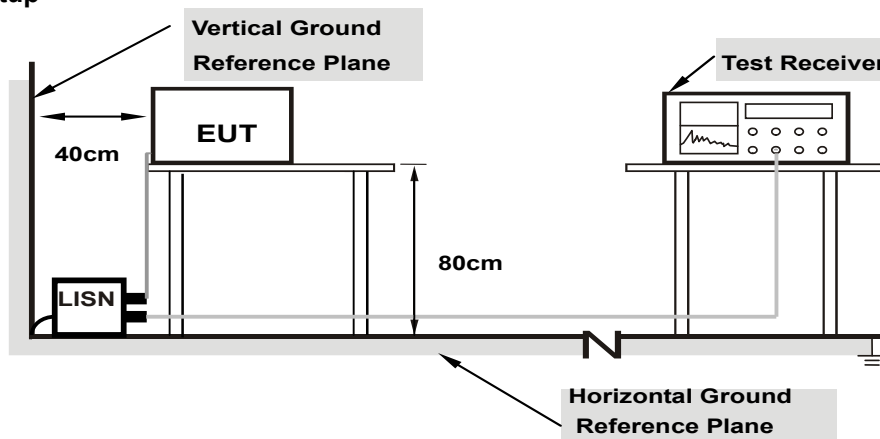

Note: 1.Support units were connected to second LISN.

For the actual test configuration, please refer to the attached file (Test Setup Photo).

4.2.6 EUT Operating Conditions

Same as 4.1.6.

4.2.7 Test Results

Test Mode A

Phase	Line (L)	Detector Function	Quasi-Peak (QP) / Average (AV)
-------	----------	-------------------	--------------------------------

No	Freq. [MHz]	Corr. Factor (dB)	Reading Value [dB (uV)]		Emission Level [dB (uV)]		Limit [dB (uV)]		Margin (dB)	
			Q.P.	AV.	Q.P.	AV.	Q.P.	AV.	Q.P.	AV.
			1	0.16564	9.63	34.13	27.36	43.76	36.99	65.18
2	0.41560	9.69	34.18	25.69	43.87	35.38	57.54	47.54	-13.67	-12.16
3	0.73233	9.70	20.34	14.73	30.04	24.43	56.00	46.00	-25.96	-21.57
4	14.74603	9.84	37.50	37.17	47.34	47.01	60.00	50.00	-12.66	-2.99
5	15.02755	9.85	38.74	38.65	48.59	48.50	60.00	50.00	-11.41	-1.50
6	18.71468	9.86	34.82	34.06	44.68	43.92	60.00	50.00	-15.32	-6.08

Remarks:

1. Q.P. and AV. are abbreviations of quasi-peak and average individually.
2. The emission levels of other frequencies were very low against the limit.
3. Margin value = Emission level - Limit value
4. Correction factor = Insertion loss + Cable loss
5. Emission Level = Correction Factor + Reading Value.

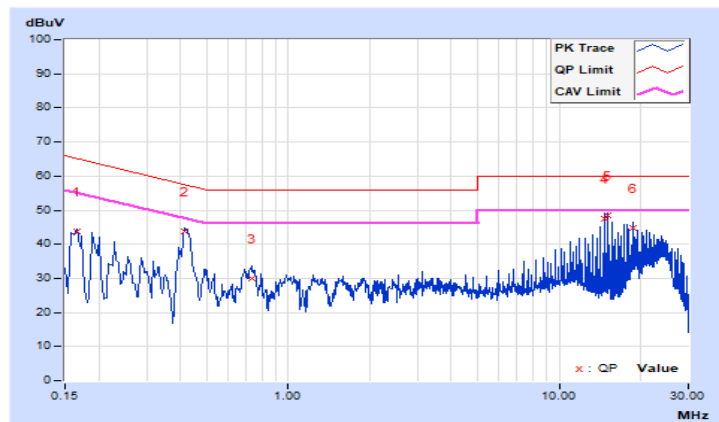

Phase	Neutral (N)	Detector Function	Quasi-Peak (QP) / Average (AV)
-------	-------------	-------------------	--------------------------------

No	Freq. [MHz]	Corr. Factor (dB)	Reading Value		Emission Level		Limit		Margin	
			[dB (uV)]		[dB (uV)]		[dB (uV)]		(dB)	
			Q.P.	AV.	Q.P.	AV.	Q.P.	AV.	Q.P.	AV.
1	0.16564	9.63	36.31	26.37	45.94	36.00	65.18	55.18	-19.24	-19.18
2	0.41588	9.69	33.00	24.70	42.69	34.39	57.53	47.53	-14.84	-13.14
3	0.72084	9.70	20.79	14.23	30.49	23.93	56.00	46.00	-25.51	-22.07
4	14.74603	9.86	37.14	37.07	47.00	46.93	60.00	50.00	-13.00	-3.07
5	17.86621	9.88	33.62	32.92	43.50	42.80	60.00	50.00	-16.50	-7.20
6	23.81723	9.88	30.37	28.07	40.25	37.95	60.00	50.00	-19.75	-12.05

Remarks:

1. Q.P. and AV. are abbreviations of quasi-peak and average individually.
2. The emission levels of other frequencies were very low against the limit.
3. Margin value = Emission level - Limit value
4. Correction factor = Insertion loss + Cable loss
5. Emission Level = Correction Factor + Reading Value.

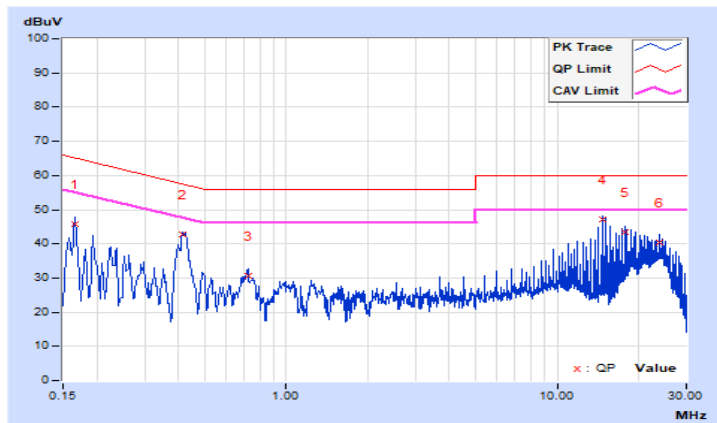

Test Mode B

Phase	Line (L)	Detector Function	Quasi-Peak (QP) / Average (AV)
-------	----------	-------------------	--------------------------------

No	Freq. [MHz]	Corr. Factor (dB)	Reading Value [dB (uV)]		Emission Level [dB (uV)]		Limit [dB (uV)]		Margin (dB)	
			Q.P.	AV.	Q.P.	AV.	Q.P.	AV.	Q.P.	AV.
			1	0.15782	9.62	35.00	23.70	44.62	33.32	65.58
2	0.41890	9.69	34.52	27.56	44.21	37.25	57.47	47.47	-13.26	-10.22
3	0.72274	9.70	21.98	15.35	31.68	25.05	56.00	46.00	-24.32	-20.95
4	11.90737	9.82	31.19	30.78	41.01	40.60	60.00	50.00	-18.99	-9.40
5	14.74212	9.84	38.30	37.96	48.14	47.80	60.00	50.00	-11.86	-2.20
6	18.71077	9.86	35.13	34.69	44.99	44.55	60.00	50.00	-15.01	-5.45

Remarks:

1. Q.P. and AV. are abbreviations of quasi-peak and average individually.
2. The emission levels of other frequencies were very low against the limit.
3. Margin value = Emission level - Limit value
4. Correction factor = Insertion loss + Cable loss
5. Emission Level = Correction Factor + Reading Value.

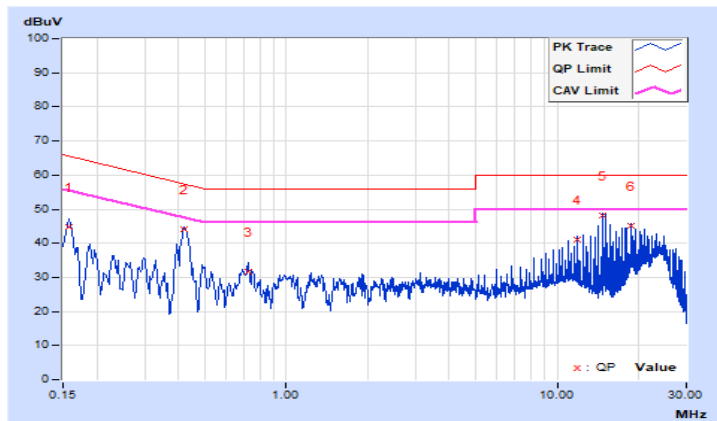

Phase	Neutral (N)	Detector Function	Quasi-Peak (QP) / Average (AV)
-------	-------------	-------------------	--------------------------------

No	Freq. [MHz]	Corr. Factor (dB)	Reading Value		Emission Level		Limit		Margin	
			[dB (uV)]		[dB (uV)]		[dB (uV)]		(dB)	
			Q.P.	AV.	Q.P.	AV.	Q.P.	AV.	Q.P.	AV.
1	0.16564	9.63	36.08	26.57	45.71	36.20	65.18	55.18	-19.47	-18.98
2	0.41890	9.69	33.35	26.42	43.04	36.11	57.47	47.47	-14.43	-11.36
3	0.72084	9.70	20.73	14.01	30.43	23.71	56.00	46.00	-25.57	-22.29
4	15.02755	9.86	36.83	36.65	46.69	46.51	60.00	50.00	-13.31	-3.49
5	17.29535	9.88	33.53	33.30	43.41	43.18	60.00	50.00	-16.59	-6.82
6	18.71077	9.89	33.62	32.88	43.51	42.77	60.00	50.00	-16.49	-7.23

Remarks:

1. Q.P. and AV. are abbreviations of quasi-peak and average individually.
2. The emission levels of other frequencies were very low against the limit.
3. Margin value = Emission level - Limit value
4. Correction factor = Insertion loss + Cable loss
5. Emission Level = Correction Factor + Reading Value.

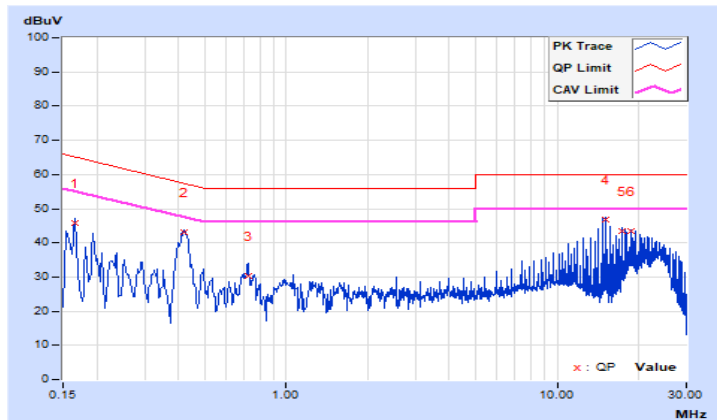

Test Mode C

Phase	Line (L)	Detector Function	Quasi-Peak (QP) / Average (AV)
-------	----------	-------------------	--------------------------------

No	Freq. [MHz]	Corr. Factor (dB)	Reading Value [dB (uV)]		Emission Level [dB (uV)]		Limit [dB (uV)]		Margin (dB)	
			Q.P.	AV.	Q.P.	AV.	Q.P.	AV.	Q.P.	AV.
			1	0.16173	9.62	36.57	28.47	46.19	38.09	65.37
2	0.41979	9.69	34.64	28.07	44.33	37.76	57.45	47.45	-13.12	-9.69
3	0.72848	9.70	21.96	15.26	31.66	24.96	56.00	46.00	-24.34	-21.04
4	8.22024	9.79	24.91	23.66	34.70	33.45	60.00	50.00	-25.30	-16.55
5	14.74212	9.84	37.77	37.46	47.61	47.30	60.00	50.00	-12.39	-2.70
6	18.71077	9.86	34.15	33.65	44.01	43.51	60.00	50.00	-15.99	-6.49

Remarks:

1. Q.P. and AV. are abbreviations of quasi-peak and average individually.
2. The emission levels of other frequencies were very low against the limit.
3. Margin value = Emission level - Limit value
4. Correction factor = Insertion loss + Cable loss
5. Emission Level = Correction Factor + Reading Value.

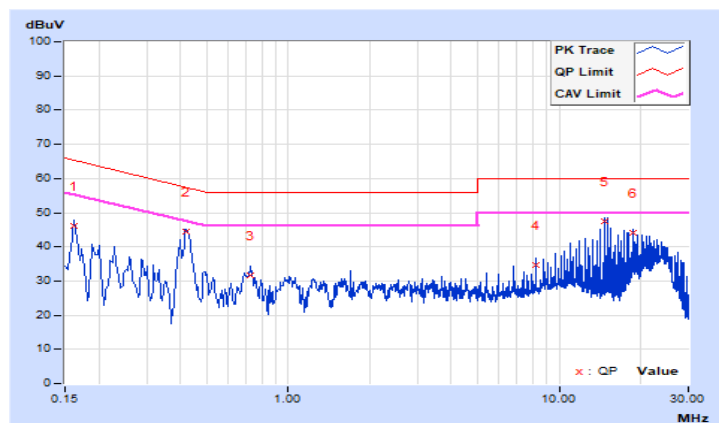

Phase	Neutral (N)	Detector Function	Quasi-Peak (QP) / Average (AV)
-------	-------------	-------------------	--------------------------------

No	Freq. [MHz]	Corr. Factor (dB)	Reading Value [dB (uV)]		Emission Level [dB (uV)]		Limit [dB (uV)]		Margin (dB)	
			Q.P.	AV.	Q.P.	AV.	Q.P.	AV.	Q.P.	AV.
			1	0.16139	9.62	36.32	27.42	45.94	37.04	65.39
2	0.18910	9.64	29.12	16.97	38.76	26.61	64.08	54.08	-25.32	-27.47
3	0.41979	9.69	33.53	26.93	43.22	36.62	57.45	47.45	-14.23	-10.83
4	0.72084	9.70	21.04	14.40	30.74	24.10	56.00	46.00	-25.26	-21.90
5	14.74212	9.86	36.96	36.76	46.82	46.62	60.00	50.00	-13.18	-3.38
6	18.14382	9.89	33.12	32.64	43.01	42.53	60.00	50.00	-16.99	-7.47

Remarks:

1. Q.P. and AV. are abbreviations of quasi-peak and average individually.
2. The emission levels of other frequencies were very low against the limit.
3. Margin value = Emission level - Limit value
4. Correction factor = Insertion loss + Cable loss
5. Emission Level = Correction Factor + Reading Value.

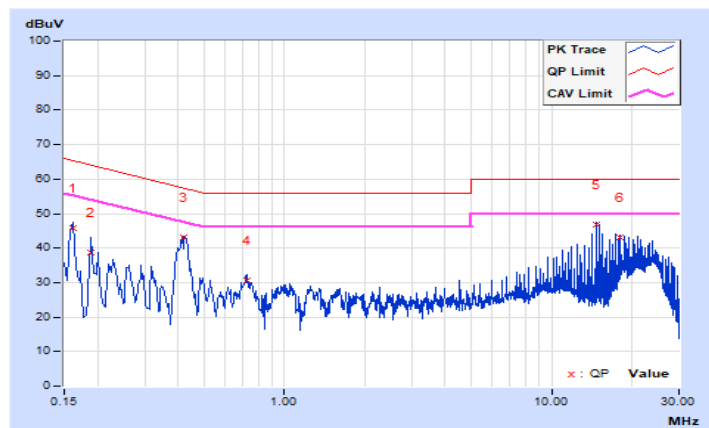

5 Pictures of Test Arrangements

Please refer to the attached file (Test Setup Photo).

Appendix – Information of the Testing Laboratories

We, Bureau Veritas Consumer Products Services (H.K.) Ltd., Taoyuan Branch, were founded in 1988 to provide our best service in EMC, Radio, Telecom and Safety consultation. Our laboratories are FCC recognized accredited test firms and accredited and approved according to ISO/IEC 17025.

If you have any comments, please feel free to contact us at the following:

Lin Kou EMC/RF Lab

Tel: 886-2-26052180

Fax: 886-2-26051924

Hsin Chu EMC/RF/Telecom Lab

Tel: 886-3-6668565

Fax: 886-3-6668323

Hwa Ya EMC/RF/Safety Lab

Tel: 886-3-3183232

Fax: 886-3-3270892

Email: service.adt@tw.bureauveritas.com

Web Site: www.bureauveritas-adt.com

The address and road map of all our labs can be found in our web site also.

--- END ---