

FCC Test Report (Co-Located)

Report No.: RFBDas-WTW-P20120218B R1

FCC ID: 2ACTO-7933DMC

Test Model: XGS 126w (with EM9191)

Series Model: XGS 136w (Refer to item 3.1 for more details)

Received Date: Mar. 18, 2022

Test Date: Jul. 28, 2022 (Test Mode A)

Sep. 20, 2022 (Test Mode B)

Issued Date: Sep. 21, 2022

Applicant: Sophos Ltd.

Address: The Pentagon, Abingdon Science Park, Abingdon, OX14 3YP United Kingdom

Issued By: Bureau Veritas Consumer Products Services (H.K.) Ltd., Taoyuan Branch

Lin Kou Laboratories

Lab Address: No. 47-2, 14th Ling, Chia Pau Vil., Lin Kou Dist., New Taipei City, Taiwan

Test Location: No. 19, Hwa Ya 2nd Rd., Wen Hwa Vil., Kwei Shan Dist., Taoyuan City 33383, Taiwan

FCC Registration /

Designation Number: 788550 / TW0003



This report is governed by, and incorporates by reference, the Conditions of Testing as posted at the date of issuance of this report at <http://www.bureauveritas.com/home/about-us/our-business/cps/about-us/terms-conditions/> and is intended for your exclusive use. Any copying or replication of this report to or for any other person or entity, or use of our name or trademark, is permitted only with our prior written permission. This report sets forth our findings solely with respect to the test samples identified herein. The results set forth in this report are not indicative or representative of the quality or characteristics of the lot from which a test sample was taken or any similar or identical product unless specifically and expressly noted. Our report includes all of the tests requested by you and the results thereof based upon the information that you provided to us. Measurement uncertainty is only provided upon request for accredited tests. Statements of conformity are based on simple acceptance criteria without taking measurement uncertainty into account, unless otherwise requested in writing. You have 60 days from date of issuance of this report to notify us of any material error or omission caused by our negligence or if you require measurement uncertainty; provided, however, that such notice shall be in writing and shall specifically address the issue you wish to raise. A failure to raise such issue within the prescribed time shall constitute your unqualified acceptance of the completeness of this report, the tests conducted and the correctness of the report contents.

Table of Contents

Release Control Record	3
1 Certificate of Conformity	4
2 Summary of Test Results	5
2.1 Measurement Uncertainty	5
2.2 Modification Record	5
3 General Information	6
3.1 General Description of EUT	6
3.2 Description of Test Modes	9
3.2.1 Test Mode Applicability and Tested Channel Detail	10
3.3 Description of Support Units	11
3.3.1 Configuration of System under Test	11
3.4 General Description of Applied Standards	12
4 Test Types and Results	13
4.1 Radiated Emission and Bandedge Measurement	13
4.1.1 Limits of Radiated Emission and Bandedge Measurement	13
4.1.2 Test Instruments	14
4.1.3 Test Procedures	15
4.1.4 Deviation from Test Standard	15
4.1.5 Test Setup	16
4.1.6 EUT Operating Conditions	17
4.1.7 Test Results	18
5 Pictures of Test Arrangements	36
Appendix – Information of the Testing Laboratories	37

Release Control Record

Issue No.	Description	Date Issued
RFBDAS-WTW-P20120218B	Original release	Aug. 12, 2022
RFBDAS-WTW-P20120218B R1	Added Test Mode B	Sep. 21, 2022

1 Certificate of Conformity

Product: Network appliance

Brand: SOPHOS

Test Model: XGS 126w (with EM9191)

Series Model: XGS 136w (Refer to item 3.1 for more details)

Sample Status: Production Unit

Applicant: Sophos Ltd.

Test Date: Jul. 28, 2022 (Test Mode A)
Sep. 20, 2022 (Test Mode B)

Standards: 47 CFR FCC Part 15, Subpart C (Section 15.247)
47 CFR FCC Part 15, Subpart E (Section 15.407)
FCC Part 22, Subpart H
FCC Part 24, Subpart E
FCC Part 27, Subpart D, F, H, L, M
FCC Part 90, Subpart R, S
47 CFR FCC Part 96
ANSI 63.26-2015
ANSI C63.10-2013

The above equipment has been tested by **Bureau Veritas Consumer Products Services (H.K.) Ltd., Taoyuan Branch**, and found compliance with the requirement of the above standards. The test record, data evaluation & Equipment Under Test (EUT) configurations represented herein are true and accurate accounts of the measurements of the sample's RF characteristics under the conditions specified in this report.

Prepared by : Pettie Chen , **Date:** Sep. 21, 2022
Pettie Chen / Senior Specialist

Approved by : Jeremy Lin , **Date:** Sep. 21, 2022
Jeremy Lin / Project Engineer

2 Summary of Test Results

Applied Standard	47 CFR FCC Part 15, Subpart C (Section 15.247) 47 CFR FCC Part 15, Subpart E (Section 15.407) FCC Part 22, Subpart H FCC Part 24, Subpart E FCC Part 27, Subpart D, F, H, L, M FCC Part 90, Subpart R, S 47 CFR FCC Part 96 ANSI 63.26-2015 ANSI C63.10-2013		
FCC Clause	Test Item	Result	Remarks
15.205 / 15.209 / 15.247(d) / 15.407(b) / (1/2/3/4(i/ii)/9)	Radiated Emissions	Pass	Meet the requirement of limit. Minimum passing margin is -1.2dB at 2390.00MHz.
2.1053 / 22.917 / 24.238 / 27.53(a) / 27.53(c)(f) / 27.53(h) / 27.53 (g) / 27.53 (m)(4)(6) / 90.543 (e) & (f) / 90.691 / 96.41(e)	Radiated Spurious Emissions	Pass	Meet the requirement of limit. Minimum passing margin is -22.15dB at 5360MHz.

2.1 Measurement Uncertainty

Where relevant, the following measurement uncertainty levels have been estimated for tests performed on the EUT as specified in CISPR 16-4-2:

Measurement	Frequency	Expanded Uncertainty (k=2) (±)
Radiated Emissions up to 1 GHz	9kHz ~ 30MHz	3.04 dB
	30MHz ~ 200MHz	3.59 dB
	200MHz ~ 1000MHz	3.60 dB
Radiated Emissions above 1 GHz	1GHz ~ 18GHz	2.29 dB
	18GHz ~ 40GHz	2.29 dB

2.2 Modification Record

There were no modifications required for compliance.

3 General Information

3.1 General Description of EUT

Product	Network appliance	
Brand	SOPHOS	
Test Model	XGS 126w (with EM9191)	
Series Model	XGS 136w	
Model Difference	Refer to Note	
Status of EUT	Production Unit	
Power Supply Rating	12 Vdc (Adapter)	
Operating Frequency	WLAN	2.4GHz: 2412~2462MHz 5.0GHz: 5180~5240MHz, 5745~5825MHz
	WCDMA Band 2	1852.4~1907.6MHz
	WCDMA Band 4	1712.4~1752.6MHz
	WCDMA Band 5	826.4~846.6MHz
	LTE Band 2	1850.7~1909.3MHz
	LTE Band 4	1710.7~1754.3MHz
	LTE Band 5	824.7~848.3MHz
	LTE Band 7	2502.5~2567.5MHz
	LTE Band 12	699.7~715.3MHz
	LTE Band 13	779.5~784.5MHz
	LTE Band 14	790.5~795.5MHz
	LTE Band 17	706.5~713.5MHz
	LTE Band 25	1850.7~1914.3MHz
	LTE Band 26	814.7~848.3MHz
	LTE Band 30	2307.5~2312.5MHz
	LTE Band 38	2572.5~2617.5MHz
	LTE Band 41	2498.5~2687.5MHz
	LTE Band 42	3552.5~3597.5MHz
	LTE Band 48	3552.5~3697.5MHz
	LTE Band 66	1710.7~1779.3MHz
LTE Band 71	665.5~695.5MHz	
5G NR n2	1852.5~1907.5MHz	
5G NR n5	826.5~846.5MHz	
5G NR n41	2506.02~2679.99MHz	
5G NR n66	1712.5~1777.5MHz	
5G NR n71	665.5~695.5MHz	
Antenna Type	Refer to Note	
Accessory Device	Refer to Note	
Cable Supplied	NA	

Note:

1. The following models are provided to this EUT.

Model	LAN port (1GbE)	LAN port (2.5G)
XGS 126w	12 ports	0
XGS 136w	10 ports	2 ports

2. The EUT contains following accessory devices.

Product	Brand	Model	Description
Adapter 1	FSP	FSP150-AHAN3	Power cord: 1.45 shielded cable with 1 core
Adapter 2	EDAC	EA11701E-1200	Power cord: 1.15 shielded cable with 1 core
WLAN Module on Mainboard	SOPHOS	7933DMC	FCC ID: 2ACTO-7933DMC
Expansion WLAN Module (Optional)	SOPHOS	7922DMC	FCC ID: 2ACTO-7922DMC
Expansion WWAN Module (Optional)	SOPHOS	N/A	With WWAN module Sierra/EM9191 (FCC ID: N7NEM91)
WLAN Dipole Antenna	WHA YU	C059-510394-A(White)	For 7933DMC / 7922DMC
WLAN Dipole Antenna	WHA YU	C059-510406-A(Black)	For 7933DMC / 7922DMC
WWAN Dipole Antenna (Optional)	WIESON	ARY113-0348-001-00	For EM9191

*Adapter 2 was the worst for the final tests.

3. The EUT with follow antennas gain is listed as table below.

Type	Dipole			Connector		SMA Jack reverse		
Gain (dBi)	Frequency (MHz)							
	2400	2450	2500	5150	5350	5750	5825	
	3.1	3.5	3.9	2.7	3.7	4.2	4.4	

Ant. Type	Fixed External antenna										
Ant. Connector	SMA										
Gain (dBi)											
Frequency (MHz)	WCDMA B2/ LTE B2	WCDMA B4/ LTE B4	WCDMA B5/ LTE B5	LTE B7	LTE B12	LTE B13	LTE B14	LTE B17	LTE B25	LTE B26	LTE B30
Gain (dBi)	0.46	-0.28	0.34	-0.48	1.47	-0.19	0.34	1.47	0.46	0.34	-1.02
Frequency (MHz)	LTE B38	LTE B41	LTE B48	LTE B66	LTE B71	n2	n5	n41	n66	n71	
Gain (dBi)	-0.48	-0.48	-3.35	-0.28	0.88	0.46	0.34	-0.48	-0.28	0.88	

* Detail antenna specification please refer to antenna datasheet and/or antenna measurement report.

4. The EUT incorporates a MIMO function. Physically, the EUT provides 3 completed transmitters and 3 receivers.

Band	Modulation Mode	TX Function
2.4GHz	802.11b	1TX (Fixed Chain 0)
	802.11g	1TX (Fixed Chain 0)
	802.11n (HT20)	3TX
	802.11n (HT40)	3TX
5GHz	802.11a	1TX (Fixed Chain 0)
	802.11n (HT20)	3TX
	802.11n (HT40)	3TX
	802.11ac (VHT20)	3TX
	802.11ac (VHT40)	3TX
	802.11ac (VHT80)	3TX

3.2 Description of Test Modes

For WLAN:

For 2.4GHz

11 channels are provided for 802.11b, 802.11g and 802.11n (HT20):

Channel	Frequency	Channel	Frequency
1	2412MHz	7	2442MHz
2	2417MHz	8	2447MHz
3	2422MHz	9	2452MHz
4	2427MHz	10	2457MHz
5	2432MHz	11	2462MHz
6	2437MHz		

7 channels are provided for 802.11n (HT40):

Channel	Frequency	Channel	Frequency
3	2422MHz	7	2442MHz
4	2427MHz	8	2447MHz
5	2432MHz	9	2452MHz
6	2437MHz		

For 5180 ~ 5240MHz:

4 channels are provided for 802.11a, 802.11n (HT20), 802.11ac (VHT20):

Channel	Frequency	Channel	Frequency
36	5180 MHz	44	5220 MHz
40	5200 MHz	48	5240 MHz

2 channels are provided for 802.11n (HT40), 802.11ac (VHT40):

Channel	Frequency	Channel	Frequency
38	5190 MHz	46	5230 MHz

1 channel is provided for 802.11ac (VHT80):

Channel	Frequency
42	5210MHz

For 5745 ~ 5825MHz:

5 channels are provided for 802.11a, 802.11n (HT20), 802.11ac (VHT20):

Channel	Frequency	Channel	Frequency
149	5745MHz	161	5805MHz
153	5765MHz	165	5825MHz
157	5785MHz		

2 channels are provided for 802.11n (HT40), 802.11ac (VHT40):

Channel	Frequency	Channel	Frequency
151	5755MHz	159	5795MHz

1 channel is provided for 802.11ac (VHT80):

Channel	Frequency
155	5775MHz

3.2.1 Test Mode Applicability and Tested Channel Detail

EUT Configure Mode	Applicable to		Description
	RE \geq 1G	RE<1G	Module Model
A	√	√	7933DMC (on Mainboard) + EM9191 (Expansion)
B	√	√	7933DMC (on Mainboard) + 7922DMC (Expansion)

Where **RE \geq 1G**: Radiated Emission above 1GHz & Bandedge Measurement **RE<1G**: Radiated Emission below 1GHz

Radiated Emission Test (Above 1GHz):

- Pre-Scan has been conducted to determine the worst-case mode from all possible combinations between available modulations, data rates and antenna ports (if EUT with antenna diversity architecture).
- Following channel(s) was (were) selected for the final test as listed below.

EUT Configure Mode	Mode	Frequency Band (MHz)	Available Channel	Tested Channel	Modulation Technology
A	2.4GHz Band: 802.11n (HT40) + LTE Band 41 (BW: 20MHz)	2412-2462	3 to 9	6 (2437.0MHz) + 41490 (2680.0MHz)	OFDM
		2506.0-2680.0	39750 to 41490		QPSK
A	5GHz Band: 802.11n (HT20) + LTE Band 41 (BW: 20MHz)	5180-5240 5745-5825	36 to 48 149 to 165	40 (5200.0MHz) + 41490 (2680.0MHz)	OFDM
		2506.0-2680.0	39750 to 41490		QPSK
B	2.4GHz Band: 802.11b + 2.4GHz Band: 802.11n (HT20)	2412-2462	1 to 13	1 (2412.0MHz) + 1 (2412.0MHz)	OFDM
		2412-2462	1 to 13		OFDM
B	5GHz Band: 802.11a + 5GHz Band: 802.11n (HT40)	5180-5240 5745-5825	36 to 48 149 to 165	36 (5180.0MHz) + 46 (5230.0MHz)	OFDM
		5180-5240 5745-5825	38 to 46 151 to 159		OFDM

Radiated Emission Test (Below 1GHz):

- Pre-Scan has been conducted to determine the worst-case mode from all possible combinations between available modulations, data rates and antenna ports (if EUT with antenna diversity architecture).
- Following channel(s) was (were) selected for the final test as listed below.

EUT Configure Mode	Mode	Frequency Band (MHz)	Available Channel	Tested Channel	Modulation Technology
A	2.4GHz Band: 802.11n (HT40) + LTE Band 41 (BW: 20MHz)	2412-2462	3 to 9	6 (2437.0MHz) + 41490 (2680.0MHz)	OFDM
		2506.0-2680.0	39750 to 41490		QPSK
A	5GHz Band: 802.11n (HT20) + LTE Band 41 (BW: 20MHz)	5180-5240 5745-5825	36 to 48 149 to 165	40 (5200.0MHz) + 41490 (2680.0MHz)	OFDM
		2506.0-2680.0	39750 to 41490		QPSK
B	2.4GHz Band: 802.11b + 2.4GHz Band: 802.11n (HT20)	2412-2462	1 to 13	1 (2412.0MHz) + 1 (2412.0MHz)	OFDM
		2412-2462	1 to 13		OFDM
B	5GHz Band: 802.11a + 5GHz Band: 802.11n (HT40)	5180-5240 5745-5825	36 to 48 149 to 165	36 (5180.0MHz) + 46 (5230.0MHz)	OFDM
		5180-5240 5745-5825	38 to 46 151 to 159		OFDM

Test Condition:

Applicable to	Environmental Conditions	Input Power	Tested by
RE≥1G	23deg. C, 68%RH	120Vac, 60Hz	Rex Wang
RE<1G	23deg. C, 68%RH	120Vac, 60Hz	Rex Wang

3.3 Description of Support Units

The EUT has been tested as an independent unit together with other necessary accessories or support units. The following support units or accessories were used to form a representative test configuration during the tests.

ID	Product	Brand	Model No.	Serial No.	FCC ID	Remarks
A.	Load	NA	NA	NA	NA	-
B.	Flash*2	Transcend	JetFlash 890 32GB	NA	NA	Supplied by applicant
C.	14" Laptop	Lenovo	L440	R9-0GFJJK	NA	-

Note:

1. All power cords of the above support units are non-shielded (1.8m).
2. Items C acted as communication a partner to transfer data.

ID	Descriptions	Qty.	Length (m)	Shielding (Yes/No)	Cores (Qty.)	Remarks
1.	RJ-45 Cable	6	1.5	N	0	RJ45 Cat.5e
2.	RJ-45 Cable	1	10	N	0	RJ45 Cat.5e
3.	RJ-45 To RS232 Cable	2	1	N	0	Supplied by applicant
4.	Fiber Cable	1	1.5	N	0	Supplied by applicant
5.	Micro USB Cable	1	1	N	0	Supplied by applicant

3.3.1 Configuration of System under Test

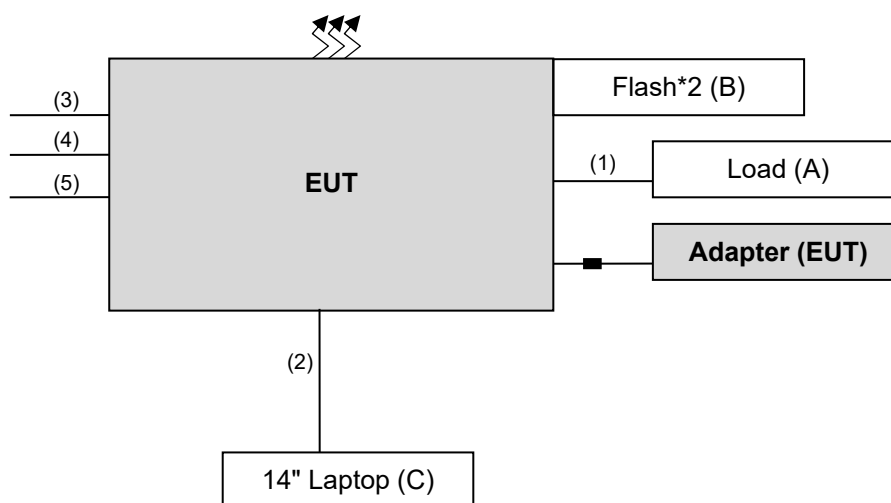

3.4 General Description of Applied Standards

The EUT is a RF Product. According to the specification of the EUT declared by the manufacturer, it must comply with the requirements of the following standards:

47 CFR FCC Part 15, Subpart C (Section 15.247)

47 CFR FCC Part 15, Subpart E (Section 15.407)

FCC Part 22, Subpart H

FCC Part 24, Subpart E

FCC Part 27, Subpart D, F, H, L, M

FCC Part 90, Subpart R, S

47 CFR FCC Part 96

ANSI 63.26-2015

ANSI C63.10-2013

All test items have been performed and recorded as per the above standards.

4 Test Types and Results

4.1 Radiated Emission and Bandedge Measurement

4.1.1 Limits of Radiated Emission and Bandedge Measurement

Radiated emissions which fall in the restricted bands must comply with the radiated emission limits specified as below table. Other emissions shall be at least 20dB below the highest level of the desired power:

Frequencies (MHz)	Field Strength (microvolts/meter)	Measurement Distance (meters)
0.009 ~ 0.490	2400/F(kHz)	300
0.490 ~ 1.705	24000/F(kHz)	30
1.705 ~ 30.0	30	30
30 ~ 88	100	3
88 ~ 216	150	3
216 ~ 960	200	3
Above 960	500	3

Note:

1. The lower limit shall apply at the transition frequencies.
2. Emission level (dBuV/m) = 20 log Emission level (uV/m).
3. For frequencies above 1000MHz, the field strength limits are based on average detector, however, the peak field strength of any emission shall not exceed the maximum permitted average limits, specified above by more than 20dB under any condition of modulation.

4.1.2 Test Instruments

Description & Manufacturer	Model No.	Serial No.	Cal. Date	Cal. Due
Software BV ADT	ADT_Radiated_ V7.6.15.9.5	NA	NA	NA
Antenna Tower & Turn BV ADT	AT100	AT93021705	NA	NA
Turn Table BV ADT	TT100	TT93021705	NA	NA
Turn Table Controller BV ADT	SC100	SC93021705	NA	NA
Test Receiver Agilent	N9038A	MY51210203	Sep. 22, 2021	Sep. 21, 2022
Spectrum Analyzer R&S	FSW43	101867	Jan. 7, 2022	Jan. 6, 2023
Pre-amplifier EMCI	EMC001340	980142	Jun. 2, 2022	Jun. 1, 2023
RF Coaxial Cable EMCI	5D-NM-BM	140903+140902	Jan. 15, 2022	Jan. 14, 2023
Preamplifier Agilent	8447D	2944A10638	May 14, 2022	May 13, 2023
Bi_Log Antenna Schwarzbeck	VULB9168	9168-160	Oct. 28, 2021	Oct. 27, 2022
RF Coaxial Cable WOKEN	8D-FB	Cable-CH9-01	May 14, 2022	May 13, 2023
Horn Antenna Schwarzbeck	9120D	9120D-1169	Nov. 14, 2021	Nov. 13, 2022
Preamplifier Agilent	8449B	3008A02367	Feb. 16, 2022	Feb. 15, 2023
RF Coaxial Cable HUBER+SUHNER&EMCI	SUCOFLEX 104& EMC104-SM-SM8000	CABLE-CH9-02 (248780+171006)	Jan. 15, 2022	Jan. 14, 2023
RF Coaxial Cable HUBER+SUHNER	SUCOFLEX 104	CABLE-CH9-(250795/4)	Jan. 15, 2022	Jan. 14, 2023
RF FLITER MICRO-TRONICS	BRM50716	060	Jan. 10, 2022	Jan. 9, 2023
RF FLITER MICRO-TRONICS	BRM17690	004	Jan. 10, 2022	Jan. 9, 2023
Boresight antenna tower fixture BV	BAF-02	5	NA	NA

- Note: 1. The calibration interval of the above test instruments is 12 months and the calibrations are traceable to NML/ROC and NIST/USA.
2. The test was performed in HwaYa Chamber 4.

4.1.3 Test Procedures

For Radiated emission below 30MHz

- a. The EUT was placed on the top of a rotating table 0.8 meters above the ground at a 3 meter chamber room. The table was rotated 360 degrees to determine the position of the highest radiation.
- b. The EUT was set 3 meters away from the interference-receiving antenna, which was mounted on the top of a variable-height antenna tower.
- c. Parallel, perpendicular, and ground-parallel orientations of the antenna are set to make the measurement.
- d. For each suspected emission, the EUT was arranged to its worst case and the rotatable table was turned from 0 degrees to 360 degrees to find the maximum reading.
- e. The test-receiver system was set to Quasi-Peak Detect Function and Specified Bandwidth with Maximum Hold Mode.

Note:

1. The resolution bandwidth and video bandwidth of test receiver/spectrum analyzer is 9kHz at frequency below 30MHz.

For Radiated emission above 30MHz

- a. The EUT was placed on the top of a rotating table 0.8 meters (for 30MHz ~ 1GHz) / 1.5 meters (for above 1GHz) above the ground at 3 meter chamber room for test. The table was rotated 360 degrees to determine the position of the highest radiation.
- b. The EUT was set 3 meters away from the interference-receiving antenna, which was mounted on the top of a variable-height antenna tower.
- c. The height of antenna is varied from one meter to four meters above the ground to determine the maximum value of the field strength. Both horizontal and vertical polarizations of the antenna are set to make the measurement.
- d. For each suspected emission, the EUT was arranged to its worst case and then the antenna was tuned to heights from 1 meter to 4 meters and the rotatable table was turned from 0 degrees to 360 degrees to find the maximum reading.
- e. The test-receiver system was set to quasi-peak detect function and specified bandwidth with maximum hold mode when the test frequency is below 1 GHz.
- f. The test-receiver system was set to peak and average detect function and specified bandwidth with maximum hold mode when the test frequency is above 1 GHz. If the peak reading value also meets average limit, measurement with the average detector is unnecessary.

Note:

1. The resolution bandwidth and video bandwidth of test receiver/spectrum analyzer is 120kHz for Quasi-peak detection (QP) at frequency below 1GHz.
2. The resolution bandwidth of test receiver/spectrum analyzer is 1 MHz and the video bandwidth is 3 MHz for Peak detection (PK) at frequency above 1GHz.
3. The resolution bandwidth of test receiver/spectrum analyzer is 1MHz and the video bandwidth is $\geq 1/T$ (Duty cycle < 98%) or 10Hz (Duty cycle $\geq 98\%$) for Average detection (AV) at frequency above 1GHz.
4. All modes of operation were investigated and the worst-case emissions are reported.

4.1.4 Deviation from Test Standard

No deviation.

4.1.5 Test Setup

For Radiated emission below 30MHz

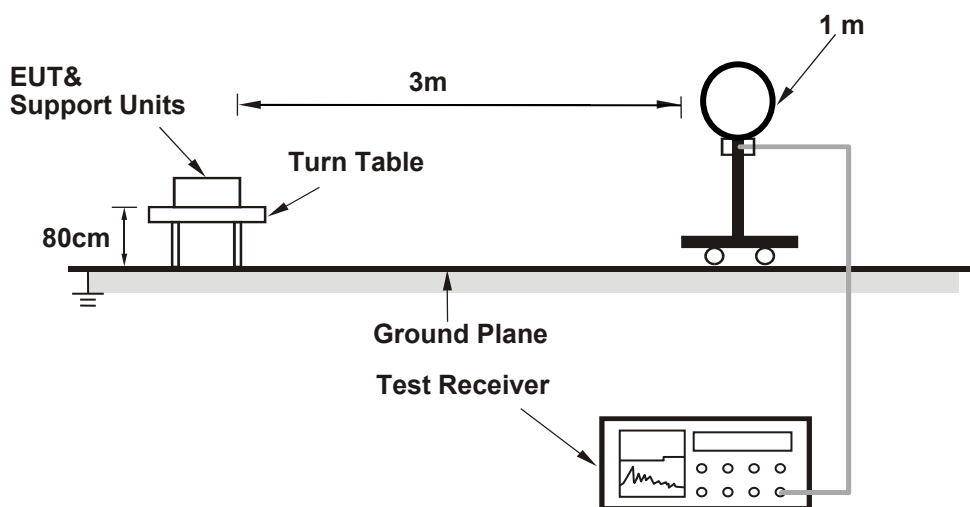

For Radiated emission 30MHz to 1GHz

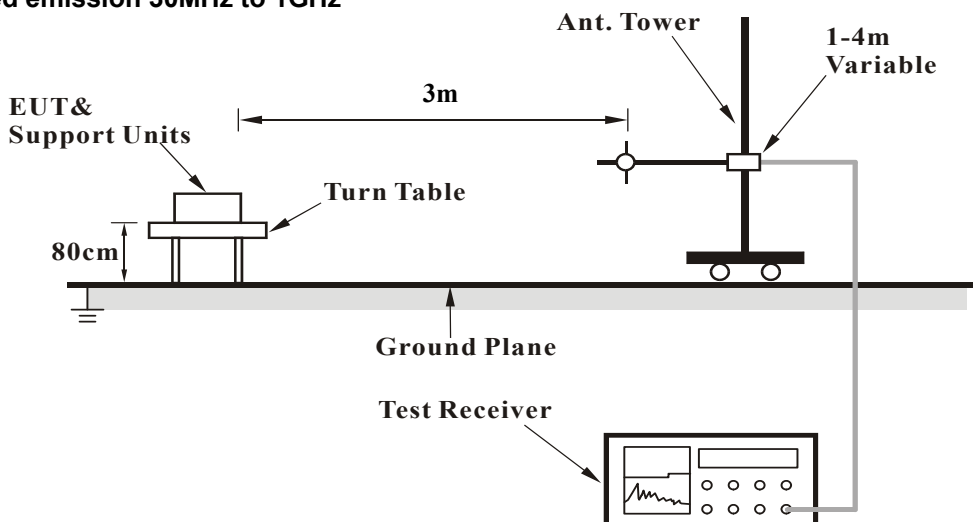

For Radiated emission above 1GHz

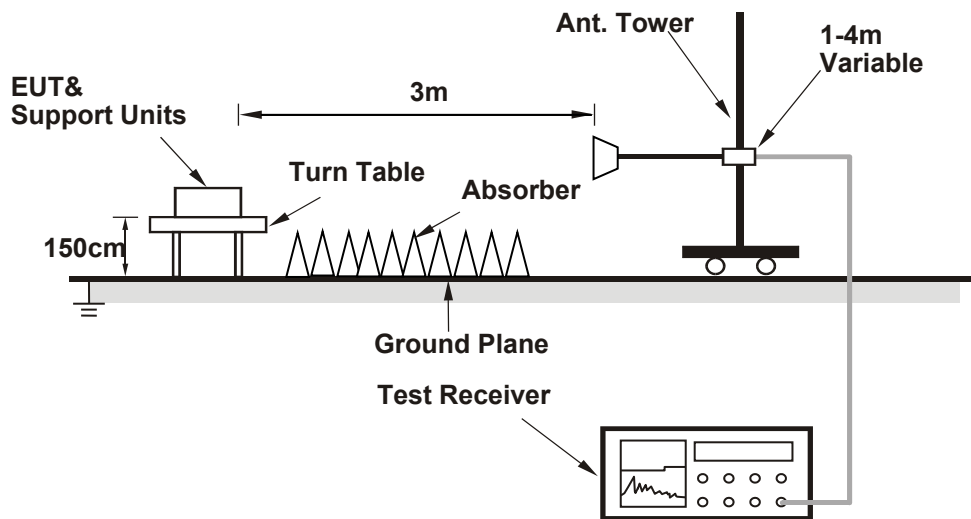

For the actual test configuration, please refer to the attached file (Test Setup Photo).

4.1.6 EUT Operating Conditions

- a. Placed the EUT on the testing table.
- b. Prepared a notebook to act as a communication partner and placed it outside of testing area.
- c. The communication partner connected with EUT via a RJ45 cable and ran a test program (CMD) to enable EUT under transmission condition continuously at specific channel frequency.
- d. The necessary accessories enable the system in full functions.

4.1.7 Test Results

Above 1GHz Data:

Test Mode A

2.4GHz Band: 802.11n (HT40) + LTE Band 41 (BW: 20MHz)

CHANNEL	CH 6	DETECTOR FUNCTION	Peak (PK) Average (AV)
FREQUENCY RANGE	1GHz ~ 40GHz		

ANTENNA POLARITY & TEST DISTANCE: HORIZONTAL AT 3 M								
NO.	FREQ. (MHz)	EMISSION LEVEL (dBuV/m)	LIMIT (dBuV/m)	MARGIN (dB)	ANTENNA HEIGHT (m)	TABLE ANGLE (Degree)	RAW VALUE (dBuV)	CORRECTION FACTOR (dB/m)
1	2390.00	57.8 PK	74.0	-16.2	1.42 H	109	25.0	32.8
2	2390.00	46.4 AV	54.0	-7.6	1.42 H	109	13.6	32.8
3	*2437.00	114.5 PK			1.42 H	109	81.7	32.8
4	*2437.00	103.5 AV			1.42 H	109	70.7	32.8
5	4874.00	48.4 PK	74.0	-25.6	2.04 H	177	42.8	5.6
6	4874.00	36.3 AV	54.0	-17.7	2.04 H	177	30.7	5.6
ANTENNA POLARITY & TEST DISTANCE: VERTICAL AT 3 M								
NO.	FREQ. (MHz)	EMISSION LEVEL (dBuV/m)	LIMIT (dBuV/m)	MARGIN (dB)	ANTENNA HEIGHT (m)	TABLE ANGLE (Degree)	RAW VALUE (dBuV)	CORRECTION FACTOR (dB/m)
1	2390.00	70.1 PK	74.0	-3.9	1.33 V	345	37.3	32.8
2	2390.00	52.8 AV	54.0	-1.2	1.33 V	345	20.0	32.8
3	*2437.00	122.5 PK			1.33 V	345	89.7	32.8
4	*2437.00	111.3 AV			1.33 V	345	78.5	32.8
5	4874.00	50.5 PK	74.0	-23.5	1.74 V	192	44.9	5.6
6	4874.00	39.0 AV	54.0	-15.0	1.74 V	192	33.4	5.6

Remarks:

1. Emission Level(dBuV/m) = Raw Value(dBuV) + Correction Factor(dB/m).
2. Correction Factor(dB/m) = Antenna Factor(dB/m) + Cable Factor(dB) – Pre-Amplifier Factor(dB).
3. Margin value = Emission Level – Limit value.
4. The other emission levels were very low against the limit.
5. " * ": Fundamental frequency.

CHANNEL		CH 41490						
Antenna Polarity & Test Distance: Horizontal at 3 m (For FCC Part 27)								
No.	Frequency (MHz)	EIRP (dBm)	Limit (dBm)	Margin (dB)	Antenna Height (m)	Table Angle (Degree)	Raw Value (dBuV)	Correction Factor (dB/m)
1	5360.00	-47.76	-25.00	-22.76	1.95 H	163	42.15	-89.91
Antenna Polarity & Test Distance: Vertical at 3 m (For FCC Part 27)								
No.	Frequency (MHz)	EIRP (dBm)	Limit (dBm)	Margin (dB)	Antenna Height (m)	Table Angle (Degree)	Raw Value (dBuV)	Correction Factor (dB/m)
1	5360.00	-47.15	-25.00	-22.15	1.66 V	5	42.76	-89.91

Remarks:

1. $EIRP(dBm) = Raw\ Value(dBuV) + Correction\ Factor(dB/m)$
2. $Correction\ Factor(dB/m) = Antenna\ Factor(dB/m) + Cable\ Factor(dB) - Pre-Amplifier\ Factor(dB) + 20\log(D) - 104.8$
3. $Margin\ value = EIRP - Limit\ value$
4. The other EIRP levels were very low against the limit.

5.0GHz Band: 802.11n (HT20) + LTE Band 41 (BW: 20MHz)

CHANNEL	CH 40	DETECTOR FUNCTION	Peak (PK) Average (AV)
FREQUENCY RANGE	1GHz ~ 40GHz		

ANTENNA POLARITY & TEST DISTANCE: HORIZONTAL AT 3 M

NO.	FREQ. (MHz)	EMISSION LEVEL (dBuV/m)	LIMIT (dBuV/m)	MARGIN (dB)	ANTENNA HEIGHT (m)	TABLE ANGLE (Degree)	RAW VALUE (dBuV)	CORRECTION FACTOR (dB/m)
1	*5200.00	110.3 PK			2.54 H	157	70.3	40.0
2	*5200.00	99.4 AV			2.54 H	157	59.4	40.0
3	#10400.00	61.4 PK	68.2	-6.8	1.91 H	163	43.9	17.5

ANTENNA POLARITY & TEST DISTANCE: VERTICAL AT 3 M

NO.	FREQ. (MHz)	EMISSION LEVEL (dBuV/m)	LIMIT (dBuV/m)	MARGIN (dB)	ANTENNA HEIGHT (m)	TABLE ANGLE (Degree)	RAW VALUE (dBuV)	CORRECTION FACTOR (dB/m)
1	*5200.00	118.4 PK			1.50 V	357	78.4	40.0
2	*5200.00	107.5 AV			1.50 V	357	67.5	40.0
3	#10400.00	59.6 PK	68.2	-8.6	1.69 V	144	42.1	17.5

Remarks:

1. Emission Level(dBuV/m) = Raw Value(dBuV) + Correction Factor(dB/m).
2. Correction Factor(dB/m) = Antenna Factor(dB/m) + Cable Factor(dB) – Pre-Amplifier Factor(dB).
3. Margin value = Emission Level – Limit value.
4. The other emission levels were very low against the limit.
5. " * " : Fundamental frequency.
6. " # " : The radiated frequency is out of the restricted band.

CHANNEL		CH 41490						
Antenna Polarity & Test Distance: Horizontal at 3 m (For FCC Part 27)								
No.	Frequency (MHz)	EIRP (dBm)	Limit (dBm)	Margin (dB)	Antenna Height (m)	Table Angle (Degree)	Raw Value (dBuV)	Correction Factor (dB/m)
1	5360.00	-47.93	-25.00	-22.93	1.96 H	166	41.98	-89.91
Antenna Polarity & Test Distance: Vertical at 3 m (For FCC Part 27)								
No.	Frequency (MHz)	EIRP (dBm)	Limit (dBm)	Margin (dB)	Antenna Height (m)	Table Angle (Degree)	Raw Value (dBuV)	Correction Factor (dB/m)
1	5360.00	-47.26	-25.00	-22.26	1.63 V	6	42.65	-89.91

Remarks:

1. $EIRP(dBm) = Raw\ Value(dBuV) + Correction\ Factor(dB/m)$
2. $Correction\ Factor(dB/m) = Antenna\ Factor(dB/m) + Cable\ Factor(dB) - Pre-Amplifier\ Factor(dB) + 20\log(D) - 104.8$
3. $Margin\ value = EIRP - Limit\ value$
4. The other EIRP levels were very low against the limit.

Test Mode B

2.4GHz Band: 802.11b + 2.4GHz Band: 802.11n (HT20)

CHANNEL	CH 1 + 1	DETECTOR FUNCTION	Peak (PK) Average (AV)
FREQUENCY RANGE	1GHz ~ 40GHz		

ANTENNA POLARITY & TEST DISTANCE: HORIZONTAL AT 3 M

NO.	FREQ. (MHz)	EMISSION LEVEL (dBuV/m)	LIMIT (dBuV/m)	MARGIN (dB)	ANTENNA HEIGHT (m)	TABLE ANGLE (Degree)	RAW VALUE (dBuV)	CORRECTION FACTOR (dB/m)
1	2390.00	61.4 PK	74.0	-12.6	2.71 H	159	28.6	32.8
2	2390.00	48.5 AV	54.0	-5.5	2.71 H	159	15.7	32.8
3	*2412.00	101.7 PK			2.71 H	159	68.8	32.9
4	*2412.00	94.4 AV			2.71 H	159	61.5	32.9
5	4824.00	48.9 PK	74.0	-25.1	2.66 H	170	43.2	5.7
6	4824.00	39.3 AV	54.0	-14.7	2.66 H	170	33.6	5.7

ANTENNA POLARITY & TEST DISTANCE: VERTICAL AT 3 M

NO.	FREQ. (MHz)	EMISSION LEVEL (dBuV/m)	LIMIT (dBuV/m)	MARGIN (dB)	ANTENNA HEIGHT (m)	TABLE ANGLE (Degree)	RAW VALUE (dBuV)	CORRECTION FACTOR (dB/m)
1	2390.00	64.4 PK	74.0	-9.6	1.80 V	166	31.6	32.8
2	2390.00	51.4 AV	54.0	-2.6	1.80 V	166	18.6	32.8
3	*2412.00	113.5 PK			1.80 V	166	80.6	32.9
4	*2412.00	105.2 AV			1.80 V	166	72.3	32.9
5	4824.00	51.9 PK	74.0	-22.1	1.88 V	164	46.2	5.7
6	4824.00	44.3 AV	54.0	-9.7	1.88 V	164	38.6	5.7

Remarks:

1. Emission Level(dBuV/m) = Raw Value(dBuV) + Correction Factor(dB/m).
2. Correction Factor(dB/m) = Antenna Factor(dB/m) + Cable Factor(dB) – Pre-Amplifier Factor(dB).
3. Margin value = Emission Level – Limit value.
4. The other emission levels were very low against the limit.
5. " * ": Fundamental frequency.

5.0GHz Band: 802.11a + 5.0GHz Band: 802.11n (HT40)

CHANNEL	CH 36 + 46	DETECTOR FUNCTION	Peak (PK) Average (AV)
FREQUENCY RANGE	1GHz ~ 40GHz		

ANTENNA POLARITY & TEST DISTANCE: HORIZONTAL AT 3 M

NO.	FREQ. (MHz)	EMISSION LEVEL (dBuV/m)	LIMIT (dBuV/m)	MARGIN (dB)	ANTENNA HEIGHT (m)	TABLE ANGLE (Degree)	RAW VALUE (dBuV)	CORRECTION FACTOR (dB/m)
1	5150.00	56.5 PK	74.0	-17.5	1.79 H	183	50.9	5.6
2	5150.00	45.7 AV	54.0	-8.3	1.79 H	183	40.1	5.6
3	*5180.00	100.3 PK			1.79 H	183	60.3	40.0
4	*5180.00	91.1 AV			1.79 H	183	51.1	40.0
5	*5230.00	103.7 PK			1.05 H	294	63.7	40.0
6	*5230.00	93.8 AV			1.05 H	294	53.8	40.0
7	5350.00	56.8 PK	74.0	-17.2	1.05 H	294	51.5	5.3
8	5350.00	45.1 AV	54.0	-8.9	1.05 H	294	39.8	5.3
9	#10360.00	59.1 PK	68.2	-9.1	2.07 H	114	41.6	17.5
10	#10460.00	58.6 PK	68.2	-9.6	2.24 H	33	41.1	17.5

ANTENNA POLARITY & TEST DISTANCE: VERTICAL AT 3 M

NO.	FREQ. (MHz)	EMISSION LEVEL (dBuV/m)	LIMIT (dBuV/m)	MARGIN (dB)	ANTENNA HEIGHT (m)	TABLE ANGLE (Degree)	RAW VALUE (dBuV)	CORRECTION FACTOR (dB/m)
1	5150.00	64.4 PK	74.0	-9.6	1.55 V	69	58.8	5.6
2	5150.00	51.7 AV	54.0	-2.3	1.55 V	69	46.1	5.6
3	*5180.00	111.3 PK			1.55 V	69	71.3	40.0
4	*5180.00	101.3 AV			1.55 V	69	61.3	40.0
5	*5230.00	112.6 PK			2.09 V	24	72.6	40.0
6	*5230.00	103.6 AV			2.09 V	24	63.6	40.0
7	5350.00	59.1 PK	74.0	-14.9	2.09 V	24	53.8	5.3
8	5350.00	45.8 AV	54.0	-8.2	2.09 V	24	40.5	5.3
9	#10360.00	60.3 PK	68.2	-7.9	1.64 V	88	42.8	17.5
10	#10460.00	60.9 PK	68.2	-7.3	2.17 V	15	43.4	17.5

Remarks:

1. Emission Level(dBuV/m) = Raw Value(dBuV) + Correction Factor(dB/m).
2. Correction Factor(dB/m) = Antenna Factor(dB/m) + Cable Factor(dB) – Pre-Amplifier Factor(dB).
3. Margin value = Emission Level – Limit value.
4. The other emission levels were very low against the limit.
5. " * ": Fundamental frequency.
6. " # ": The radiated frequency is out of the restricted band.

Below 1GHz data

Test Mode A

2.4GHz Band: 802.11n (HT40) + LTE Band 41 (BW: 20MHz)

CHANNEL	CH 6	DETECTOR FUNCTION	Quasi-Peak (QP)
FREQUENCY RANGE	9kHz ~ 1GHz		

ANTENNA POLARITY & TEST DISTANCE: HORIZONTAL AT 3 M								
NO.	FREQ. (MHz)	EMISSION LEVEL (dBuV/m)	LIMIT (dBuV/m)	MARGIN (dB)	ANTENNA HEIGHT (m)	TABLE ANGLE (Degree)	RAW VALUE (dBuV)	CORRECTION FACTOR (dB/m)
1	83.35	27.3 QP	40.0	-12.7	1.00 H	231	41.5	-14.2
2	246.31	30.0 QP	46.0	-16.0	1.50 H	226	39.2	-9.2
3	288.99	31.3 QP	46.0	-14.7	1.50 H	66	38.5	-7.2
4	320.03	34.3 QP	46.0	-11.7	1.25 H	231	40.7	-6.4
5	482.02	34.7 QP	46.0	-11.3	1.00 H	7	37.6	-2.9
6	528.58	32.4 QP	46.0	-13.6	1.00 H	42	34.3	-1.9

Remarks:

1. Emission Level(dBuV/m) = Raw Value(dBuV) + Correction Factor(dB/m).
2. Correction Factor(dB/m) = Antenna Factor(dB/m) + Cable Factor(dB) – Pre-Amplifier Factor(dB).
3. The other emission levels were very low against the limit of frequency range 30MHz ~ 1000MHz.
4. Margin value = Emission Level – Limit value.
5. The emission levels were very low against the limit of frequency range 9kHz ~ 30MHz: the amplitude of spurious emissions attenuated more than 20 dB below the permissible value to be report.

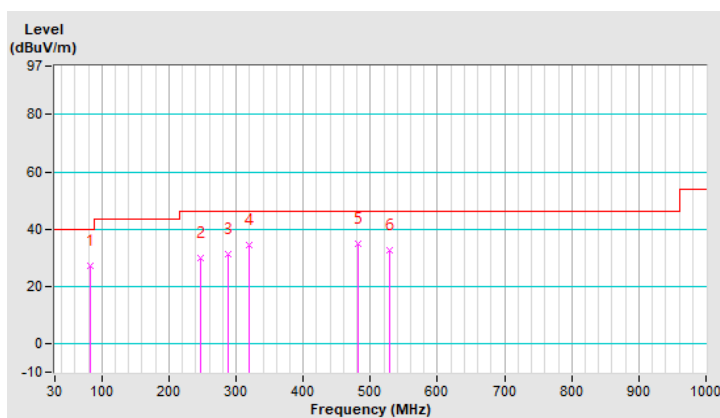

CHANNEL	CH 6	DETECTOR FUNCTION	Quasi-Peak (QP)
FREQUENCY RANGE	9kHz ~ 1GHz		

ANTENNA POLARITY & TEST DISTANCE: VERTICAL AT 3 M								
NO.	FREQ. (MHz)	EMISSION LEVEL (dBuV/m)	LIMIT (dBuV/m)	MARGIN (dB)	ANTENNA HEIGHT (m)	TABLE ANGLE (Degree)	RAW VALUE (dBuV)	CORRECTION FACTOR (dB/m)
1	99.84	29.3 QP	43.5	-14.2	1.00 V	128	43.0	-13.7
2	135.73	32.1 QP	43.5	-11.4	1.50 V	276	41.8	-9.7
3	331.67	28.7 QP	46.0	-17.3	1.25 V	150	34.7	-6.0
4	389.87	35.7 QP	46.0	-10.3	1.00 V	225	40.9	-5.2
5	502.39	37.7 QP	46.0	-8.3	1.00 V	265	40.3	-2.6
6	641.10	37.2 QP	46.0	-8.8	1.50 V	345	36.8	0.4

Remarks:

1. Emission Level(dBuV/m) = Raw Value(dBuV) + Correction Factor(dB/m).
2. Correction Factor(dB/m) = Antenna Factor(dB/m) + Cable Factor(dB) – Pre-Amplifier Factor(dB).
3. The other emission levels were very low against the limit of frequency range 30MHz ~ 1000MHz.
4. Margin value = Emission Level – Limit value.
5. The emission levels were very low against the limit of frequency range 9kHz ~ 30MHz: the amplitude of spurious emissions attenuated more than 20 dB below the permissible value to be report.

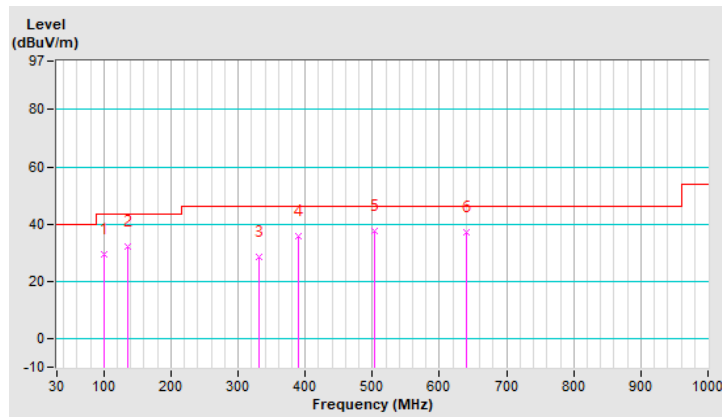

CHANNEL	CH 41490	FREQUENCY RANGE	Below 1000 MHz
---------	----------	-----------------	----------------

Antenna Polarity & Test Distance: Horizontal at 3 M (For FCC Part 27)

No	Frequency (MHz)	EIRP (dBm)	Limit (dBm)	Margin (dB)	Antenna Height (m)	Table Angle (Degree)	Raw Value (dBuV)	Correction Factor (dB/m)
1	78.50	-54.80	-25.00	-29.80	1.50 H	17	53.70	-108.50
2	177.44	-54.10	-25.00	-29.10	1.00 H	129	51.00	-105.10
3	247.28	-51.70	-25.00	-26.70	1.50 H	22	52.70	-104.40
4	338.46	-50.60	-25.00	-25.60	1.00 H	118	50.80	-101.40
5	429.64	-54.40	-25.00	-29.40	1.25 H	243	44.80	-99.20
6	599.39	-53.10	-25.00	-28.10	1.00 H	72	42.60	-95.70

Remarks:

1. $EIRP(dBm) = Raw\ Value(dBuV) + Correction\ Factor(dB/m)$
2. $Correction\ Factor(dB/m) = Antenna\ Factor(dB/m) + Cable\ Factor(dB) - Pre-Amplifier\ Factor(dB) + 20\log(D) - 104.8$
3. $Margin\ value = EIRP - Limit\ value$
4. The other EIRP levels were very low against the limit of frequency range 30 MHz ~ 1 GHz.
5. The EIRP levels were very low against the limit of frequency range 9 kHz ~ 30 MHz: the amplitude of spurious emissions attenuated more than 20 dB below the permissible value to be report.

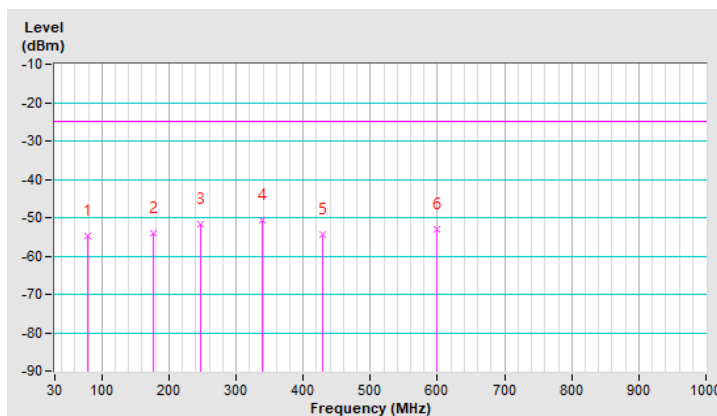

CHANNEL	CH 41490	FREQUENCY RANGE	Below 1000 MHz
---------	----------	-----------------	----------------

Antenna Polarity & Test Distance: Vertical at 3 M (For FCC Part 27)

No	Frequency (MHz)	EIRP (dBm)	Limit (dBm)	Margin (dB)	Antenna Height (m)	Table Angle (Degree)	Raw Value (dBuV)	Correction Factor (dB/m)
1	32.91	-51.10	-25.00	-26.10	1.50 V	295	54.30	-105.40
2	81.41	-55.90	-25.00	-30.90	1.00 V	37	53.30	-109.20
3	261.83	-51.70	-25.00	-26.70	1.25 V	15	52.00	-103.70
4	323.91	-49.90	-25.00	-24.90	1.00 V	107	51.70	-101.60
5	598.42	-55.60	-25.00	-30.60	1.00 V	115	40.10	-95.70
6	944.71	-51.50	-25.00	-26.50	1.25 V	215	37.60	-89.10

Remarks:

1. $EIRP(dBm) = Raw\ Value(dBuV) + Correction\ Factor(dB/m)$
2. $Correction\ Factor(dB/m) = Antenna\ Factor(dB/m) + Cable\ Factor(dB) - Pre-Amplifier\ Factor(dB) + 20\log(D) - 104.8$
3. $Margin\ value = EIRP - Limit\ value$
4. The other EIRP levels were very low against the limit of frequency range 30 MHz ~ 1 GHz.
5. The EIRP levels were very low against the limit of frequency range 9 kHz ~ 30 MHz: the amplitude of spurious emissions attenuated more than 20 dB below the permissible value to be report.

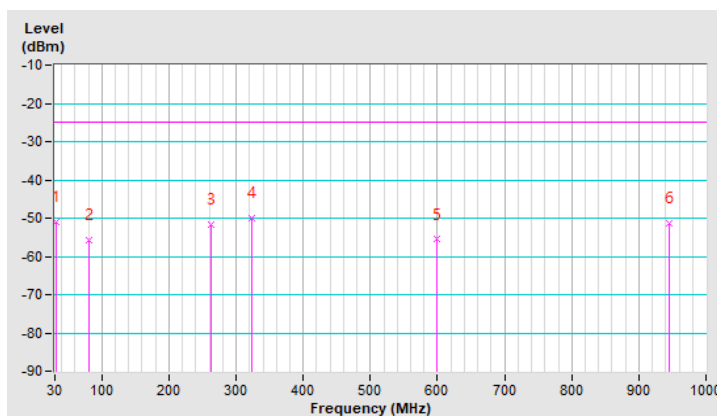

5GHz Band: 802.11n (HT20) + LTE Band 41 (BW: 20MHz)

CHANNEL	CH 40	DETECTOR FUNCTION	Quasi-Peak (QP)
FREQUENCY RANGE	9kHz ~ 1GHz		

ANTENNA POLARITY & TEST DISTANCE: HORIZONTAL AT 3 M

NO.	FREQ. (MHz)	EMISSION LEVEL (dBuV/m)	LIMIT (dBuV/m)	MARGIN (dB)	ANTENNA HEIGHT (m)	TABLE ANGLE (Degree)	RAW VALUE (dBuV)	CORRECTION FACTOR (dB/m)
1	38.73	27.5 QP	40.0	-12.5	1.50 H	80	37.4	-9.9
2	138.64	26.9 QP	43.5	-16.6	1.00 H	253	36.3	-9.4
3	198.78	27.0 QP	43.5	-16.5	1.25 H	85	38.6	-11.6
4	246.31	29.0 QP	46.0	-17.0	1.00 H	35	38.2	-9.2
5	434.49	27.7 QP	46.0	-18.3	1.00 H	67	31.4	-3.7
6	940.83	34.1 QP	46.0	-11.9	2.00 H	288	27.8	6.3

Remarks:

1. Emission Level(dBuV/m) = Raw Value(dBuV) + Correction Factor(dB/m).
2. Correction Factor(dB/m) = Antenna Factor(dB/m) + Cable Factor(dB) – Pre-Amplifier Factor(dB).
3. The other emission levels were very low against the limit of frequency range 30MHz ~ 1000MHz.
4. Margin value = Emission Level – Limit value.
5. The emission levels were very low against the limit of frequency range 9kHz ~ 30MHz: the amplitude of spurious emissions attenuated more than 20 dB below the permissible value to be report.

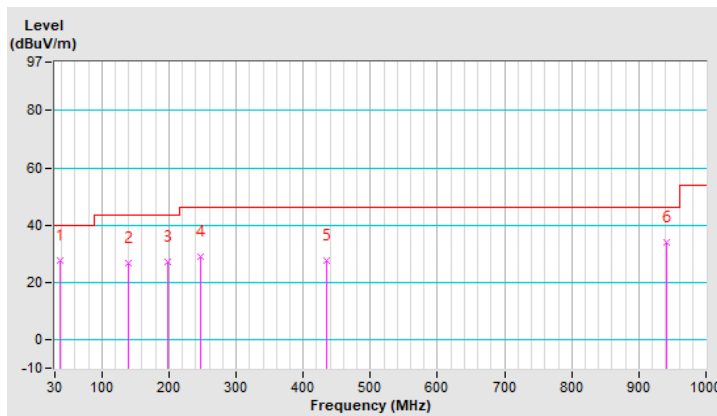

CHANNEL	CH 40	DETECTOR FUNCTION	Quasi-Peak (QP)
FREQUENCY RANGE	9kHz ~ 1GHz		

ANTENNA POLARITY & TEST DISTANCE: VERTICAL AT 3 M								
NO.	FREQ. (MHz)	EMISSION LEVEL (dBuV/m)	LIMIT (dBuV/m)	MARGIN (dB)	ANTENNA HEIGHT (m)	TABLE ANGLE (Degree)	RAW VALUE (dBuV)	CORRECTION FACTOR (dB/m)
1	64.92	35.8 QP	40.0	-4.2	1.00 V	218	46.2	-10.4
2	180.35	23.8 QP	43.5	-19.7	1.00 V	66	34.0	-10.2
3	325.85	29.2 QP	46.0	-16.8	1.50 V	133	35.3	-6.1
4	427.70	34.6 QP	46.0	-11.4	1.25 V	348	38.7	-4.1
5	561.56	37.9 QP	46.0	-8.1	1.00 V	28	39.2	-1.3
6	623.64	34.2 QP	46.0	-11.8	1.00 V	7	34.2	0.0

Remarks:

1. Emission Level(dBuV/m) = Raw Value(dBuV) + Correction Factor(dB/m).
2. Correction Factor(dB/m) = Antenna Factor(dB/m) + Cable Factor(dB) – Pre-Amplifier Factor(dB).
3. The other emission levels were very low against the limit of frequency range 30MHz ~ 1000MHz.
4. Margin value = Emission Level – Limit value.
5. The emission levels were very low against the limit of frequency range 9kHz ~ 30MHz: the amplitude of spurious emissions attenuated more than 20 dB below the permissible value to be report.

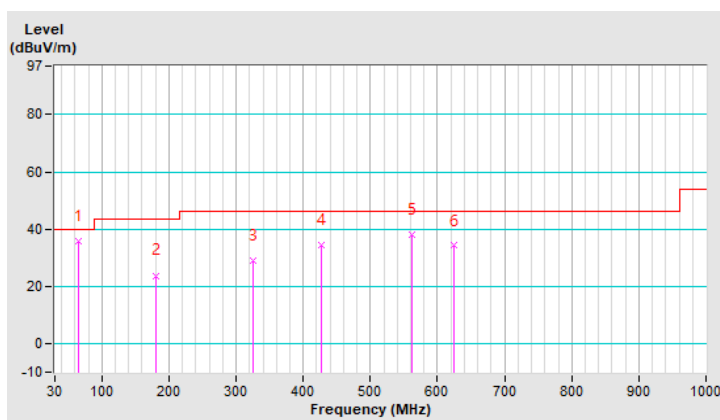

CHANNEL	CH 41490	FREQUENCY RANGE	Below 1000 MHz
---------	----------	-----------------	----------------

Antenna Polarity & Test Distance: Horizontal at 3 M (For FCC Part 27)								
No	Frequency (MHz)	EIRP (dBm)	Limit (dBm)	Margin (dB)	Antenna Height (m)	Table Angle (Degree)	Raw Value (dBuV)	Correction Factor (dB/m)
1	82.38	-52.90	-25.00	-27.90	1.50 H	108	56.40	-109.30
2	218.18	-53.80	-25.00	-28.80	1.50 H	47	52.50	-106.30
3	319.06	-52.50	-25.00	-27.50	1.00 H	116	49.30	-101.80
4	548.95	-55.70	-25.00	-30.70	1.00 H	162	41.20	-96.90
5	602.30	-55.70	-25.00	-30.70	1.25 H	94	39.90	-95.60
6	947.62	-54.70	-25.00	-29.70	1.00 H	235	34.50	-89.20

Remarks:

1. $EIRP(dBm) = Raw\ Value(dBuV) + Correction\ Factor(dB/m)$
2. $Correction\ Factor(dB/m) = Antenna\ Factor(dB/m) + Cable\ Factor(dB) - Pre-Amplifier\ Factor(dB) + 20\log(D) - 104.8$
3. $Margin\ value = EIRP - Limit\ value$
4. The other EIRP levels were very low against the limit of frequency range 30 MHz ~ 1 GHz.
5. The EIRP levels were very low against the limit of frequency range 9 kHz ~ 30 MHz: the amplitude of spurious emissions attenuated more than 20 dB below the permissible value to be report.

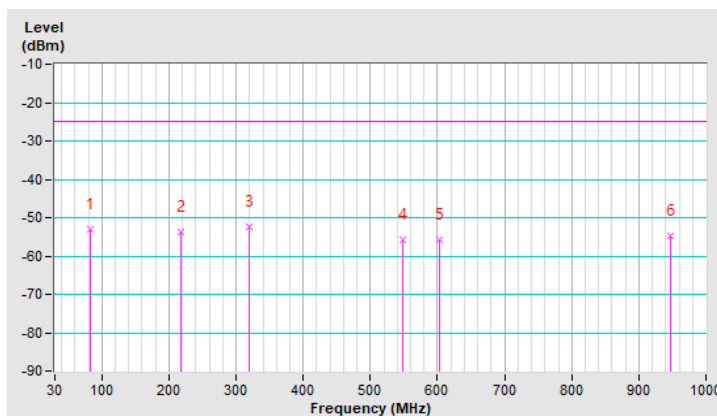

CHANNEL	CH 41490	FREQUENCY RANGE	Below 1000 MHz
---------	----------	-----------------	----------------

Antenna Polarity & Test Distance: Vertical at 3 M (For FCC Part 27)

No	Frequency (MHz)	EIRP (dBm)	Limit (dBm)	Margin (dB)	Antenna Height (m)	Table Angle (Degree)	Raw Value (dBuV)	Correction Factor (dB/m)
1	32.91	-51.60	-25.00	-26.60	1.50 V	192	53.80	-105.40
2	87.23	-52.00	-25.00	-27.00	2.00 V	283	58.00	-110.00
3	247.28	-51.50	-25.00	-26.50	1.00 V	34	52.90	-104.40
4	325.85	-50.20	-25.00	-25.20	2.00 V	98	51.20	-101.40
5	423.82	-54.30	-25.00	-29.30	1.00 V	235	45.20	-99.50
6	945.68	-51.60	-25.00	-26.60	1.00 V	18	37.50	-89.10

Remarks:

1. $EIRP(dBm) = Raw\ Value(dBuV) + Correction\ Factor(dB/m)$
2. $Correction\ Factor(dB/m) = Antenna\ Factor(dB/m) + Cable\ Factor(dB) - Pre-Amplifier\ Factor(dB) + 20\log(D) - 104.8$
3. $Margin\ value = EIRP - Limit\ value$
4. The other EIRP levels were very low against the limit of frequency range 30 MHz ~ 1 GHz.
5. The EIRP levels were very low against the limit of frequency range 9 kHz ~ 30 MHz: the amplitude of spurious emissions attenuated more than 20 dB below the permissible value to be report.

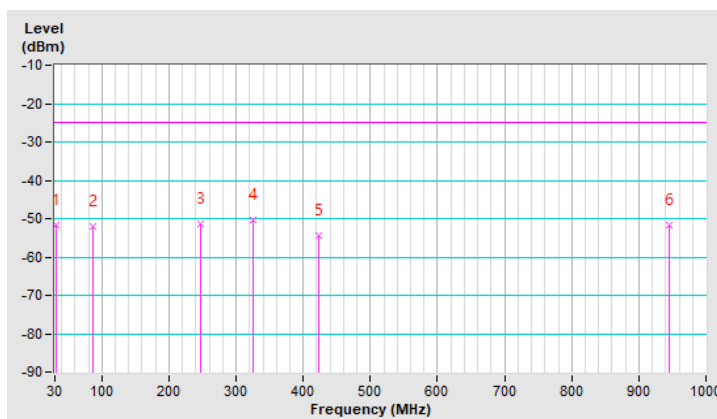

Test Mode B

2.4GHz Band: 802.11b + 2.4GHz Band: 802.11n (HT20)

CHANNEL	CH 1 + 1	DETECTOR FUNCTION	Quasi-Peak (QP)
FREQUENCY RANGE	9kHz ~ 1GHz		

ANTENNA POLARITY & TEST DISTANCE: HORIZONTAL AT 3 M								
NO.	FREQ. (MHz)	EMISSION LEVEL (dBuV/m)	LIMIT (dBuV/m)	MARGIN (dB)	ANTENNA HEIGHT (m)	TABLE ANGLE (Degree)	RAW VALUE (dBuV)	CORRECTION FACTOR (dB/m)
1	32.91	29.8 QP	40.0	-10.2	1.00 H	224	39.9	-10.1
2	112.45	36.6 QP	43.5	-6.9	1.50 H	67	48.5	-11.9
3	176.47	27.3 QP	43.5	-16.2	1.50 H	117	37.0	-9.7
4	315.18	29.7 QP	46.0	-16.3	1.00 H	122	36.2	-6.5
5	545.07	28.0 QP	46.0	-18.0	1.25 H	330	29.6	-1.6
6	674.08	39.5 QP	46.0	-6.5	1.00 H	280	39.0	0.5

Remarks:

1. Emission Level(dBuV/m) = Raw Value(dBuV) + Correction Factor(dB/m).
2. Correction Factor(dB/m) = Antenna Factor(dB/m) + Cable Factor(dB) – Pre-Amplifier Factor(dB).
3. The other emission levels were very low against the limit of frequency range 30MHz ~ 1000MHz.
4. Margin value = Emission Level – Limit value.
5. The emission levels were very low against the limit of frequency range 9kHz ~ 30MHz: the amplitude of spurious emissions attenuated more than 20 dB below the permissible value to be report.

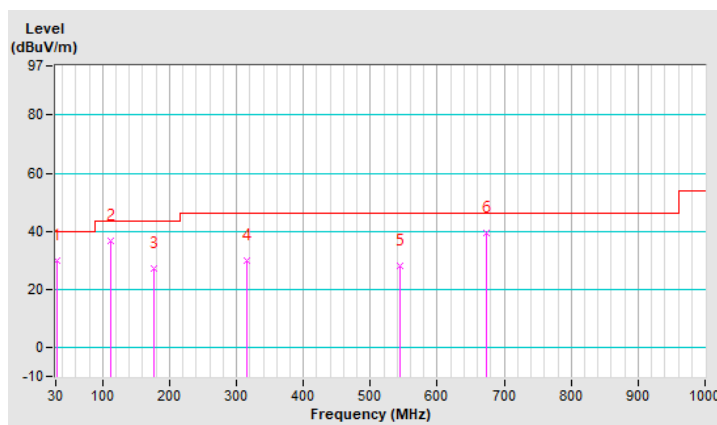

CHANNEL	CH 1 + 1	DETECTOR FUNCTION	Quasi-Peak (QP)
FREQUENCY RANGE	9kHz ~ 1GHz		

ANTENNA POLARITY & TEST DISTANCE: VERTICAL AT 3 M								
NO.	FREQ. (MHz)	EMISSION LEVEL (dBuV/m)	LIMIT (dBuV/m)	MARGIN (dB)	ANTENNA HEIGHT (m)	TABLE ANGLE (Degree)	RAW VALUE (dBuV)	CORRECTION FACTOR (dB/m)
1	119.24	27.7 QP	43.5	-15.8	1.50 V	266	39.0	-11.3
2	325.85	29.2 QP	46.0	-16.8	1.50 V	133	35.3	-6.1
3	456.80	32.5 QP	46.0	-13.5	1.00 V	149	35.8	-3.3
4	510.15	31.5 QP	46.0	-14.5	2.00 V	1	33.7	-2.2
5	588.72	33.8 QP	46.0	-12.2	1.00 V	346	34.4	-0.6
6	965.08	35.3 QP	54.0	-18.7	1.25 V	18	28.8	6.5

Remarks:

1. Emission Level(dBuV/m) = Raw Value(dBuV) + Correction Factor(dB/m).
2. Correction Factor(dB/m) = Antenna Factor(dB/m) + Cable Factor(dB) – Pre-Amplifier Factor(dB).
3. The other emission levels were very low against the limit of frequency range 30MHz ~ 1000MHz.
4. Margin value = Emission Level – Limit value.
5. The emission levels were very low against the limit of frequency range 9kHz ~ 30MHz: the amplitude of spurious emissions attenuated more than 20 dB below the permissible value to be report.

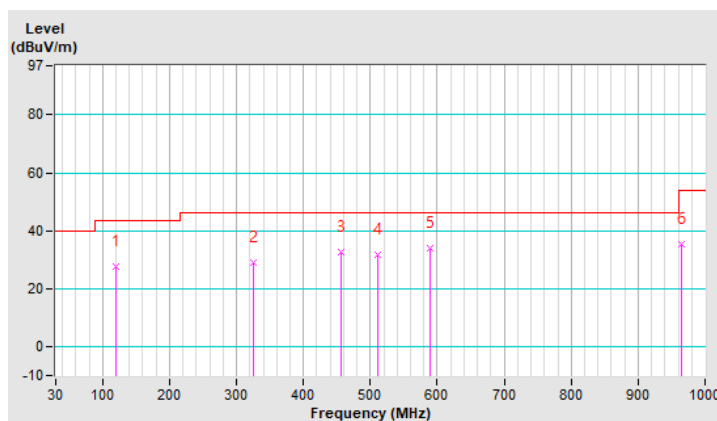

5.0GHz Band: 802.11a + 5.0GHz Band: 802.11n (HT40)

CHANNEL	CH 36 + 46	DETECTOR FUNCTION	Quasi-Peak (QP)
FREQUENCY RANGE	9kHz ~ 1GHz		

ANTENNA POLARITY & TEST DISTANCE: HORIZONTAL AT 3 M								
NO.	FREQ. (MHz)	EMISSION LEVEL (dBuV/m)	LIMIT (dBuV/m)	MARGIN (dB)	ANTENNA HEIGHT (m)	TABLE ANGLE (Degree)	RAW VALUE (dBuV)	CORRECTION FACTOR (dB/m)
1	32.91	32.6 QP	40.0	-7.4	1.00 H	2	42.7	-10.1
2	135.73	23.7 QP	43.5	-19.8	1.50 H	103	33.4	-9.7
3	321.97	32.8 QP	46.0	-13.2	1.50 H	231	39.1	-6.3
4	386.96	31.9 QP	46.0	-14.1	1.00 H	42	37.2	-5.3
5	675.05	35.5 QP	46.0	-10.5	2.00 H	7	35.0	0.5
6	978.66	34.0 QP	54.0	-20.0	1.00 H	29	27.7	6.3

Remarks:

1. Emission Level(dBuV/m) = Raw Value(dBuV) + Correction Factor(dB/m).
2. Correction Factor(dB/m) = Antenna Factor(dB/m) + Cable Factor(dB) – Pre-Amplifier Factor(dB).
3. The other emission levels were very low against the limit of frequency range 30MHz ~ 1000MHz.
4. Margin value = Emission Level – Limit value.
5. The emission levels were very low against the limit of frequency range 9kHz ~ 30MHz: the amplitude of spurious emissions attenuated more than 20 dB below the permissible value to be report.

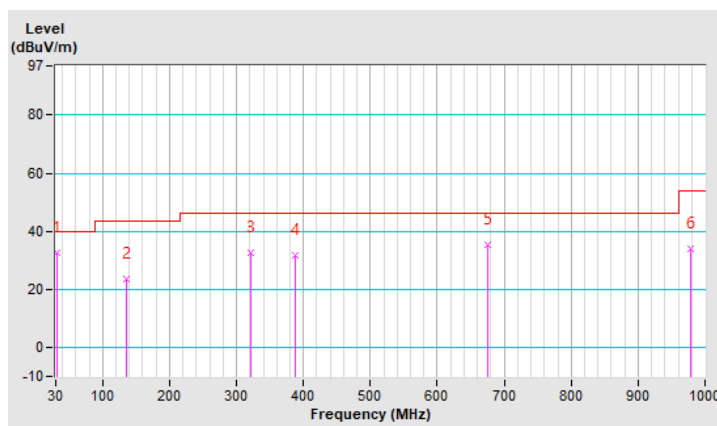

CHANNEL	CH 36 + 46	DETECTOR FUNCTION	Quasi-Peak (QP)
FREQUENCY RANGE	9kHz ~ 1GHz		

ANTENNA POLARITY & TEST DISTANCE: VERTICAL AT 3 M								
NO.	FREQ. (MHz)	EMISSION LEVEL (dBuV/m)	LIMIT (dBuV/m)	MARGIN (dB)	ANTENNA HEIGHT (m)	TABLE ANGLE (Degree)	RAW VALUE (dBuV)	CORRECTION FACTOR (dB/m)
1	119.24	29.0 QP	43.5	-14.5	1.00 V	337	40.3	-11.3
2	178.41	24.3 QP	43.5	-19.2	1.00 V	70	34.2	-9.9
3	354.95	29.9 QP	46.0	-16.1	1.25 V	110	35.8	-5.9
4	458.74	31.9 QP	46.0	-14.1	1.50 V	153	35.1	-3.2
5	623.64	33.8 QP	46.0	-12.2	1.00 V	6	33.8	0.0
6	678.93	39.7 QP	46.0	-6.3	1.50 V	62	39.1	0.6

Remarks:

1. Emission Level(dBuV/m) = Raw Value(dBuV) + Correction Factor(dB/m).
2. Correction Factor(dB/m) = Antenna Factor(dB/m) + Cable Factor(dB) – Pre-Amplifier Factor(dB).
3. The other emission levels were very low against the limit of frequency range 30MHz ~ 1000MHz.
4. Margin value = Emission Level – Limit value.
5. The emission levels were very low against the limit of frequency range 9kHz ~ 30MHz: the amplitude of spurious emissions attenuated more than 20 dB below the permissible value to be report.

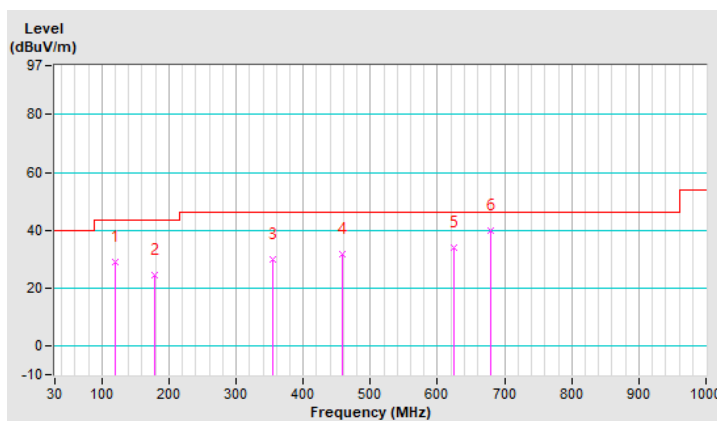

5 Pictures of Test Arrangements

Please refer to the attached file (Test Setup Photo).

Appendix – Information of the Testing Laboratories

We, Bureau Veritas Consumer Products Services (H.K.) Ltd., Taoyuan Branch, were founded in 1988 to provide our best service in EMC, Radio, Telecom and Safety consultation. Our laboratories are FCC recognized accredited test firms and accredited and approved according to ISO/IEC 17025.

If you have any comments, please feel free to contact us at the following:

Lin Kou EMC/RF Lab

Tel: 886-2-26052180

Fax: 886-2-26051924

Hsin Chu EMC/RF/Telecom Lab

Tel: 886-3-6668565

Fax: 886-3-6668323

Hwa Ya EMC/RF/Safety Lab

Tel: 886-3-3183232

Fax: 886-3-3270892

Email: service.adt@tw.bureauveritas.com

Web Site: www.bureauveritas-adt.com

The address and road map of all our labs can be found in our web site also.

--- END ---