



# CERTIFICATION TEST REPORT

**Report Number.** : 4789458470-FR1V3

**Applicant** : Honeywell Analytics Inc  
405 Barclay Blvd, Lincolnshire, Illinois, 60069, United States

**Model** : Vertex Edge Analyzer

**FCC ID** : 2ACSZVERTEXEDGE  
**IC** : 12190A-VERTEXEDGE

**EUT Description** : NFC

**Test Standard(s)** : FCC 47 CFR PART 15 SUBPART C  
ISED RSS-210 ISSUE 10  
ISED RSS-GEN ISSUE 5

**Date Of Issue:**  
August 07, 2020

**Prepared by:**  
UL Korea, Ltd.  
26th floor, 152, Teheran-ro, Gangnam-gu Seoul, 06236, Korea

Suwon Test Site: UL Korea, Ltd. Suwon Laboratory  
218 Maeyeong-ro, Yeongtong-gu,  
Suwon-si, Gyeonggi-do, 16675, Korea  
TEL: (031) 337-9902  
FAX: (031) 213-5433



**Testing Laboratory**  
**TL-637**

Revision History

<u>Rev.</u>	<u>Issue Date</u>	<u>Revisions</u>	<u>Revised By</u>
V1	07/16/20	Initial issue	Robby Lee
V2	08/06/20	Updated for the additional test	Robby Lee
V3	08/07/20	Updated the description to TCB's question	Robby Lee

## TABLE OF CONTENTS

<b>1. ATTESTATION OF TEST RESULTS .....</b>	<b>4</b>
<b>2. TEST METHODOLOGY .....</b>	<b>5</b>
<b>3. FACILITIES AND ACCREDITATION .....</b>	<b>5</b>
<b>4. CALIBRATION AND UNCERTAINTY .....</b>	<b>6</b>
4.1. <i>MEASURING INSTRUMENT CALIBRATION.....</i>	6
4.2. <i>SAMPLE CALCULATION.....</i>	6
4.3. <i>MEASUREMENT UNCERTAINTY .....</i>	6
4.4. <i>DECISION RULE .....</i>	6
<b>5. EQUIPMENT UNDER TEST.....</b>	<b>7</b>
5.1. <i>DESCRIPTION OF EUT.....</i>	7
5.2. <i>MAXIMUM E-FIELD STRENGTH.....</i>	7
5.3. <i>WORST-CASE CONFIGURATION AND MODE .....</i>	7
5.4. <i>DESCRIPTION OF TEST SETUP .....</i>	8
<b>6. TEST AND MEASUREMENT EQUIPMENT .....</b>	<b>10</b>
<b>7. OCCUPIED BANDWIDTH .....</b>	<b>11</b>
<b>8. 20dB BANDWIDTH .....</b>	<b>12</b>
<b>9. RADIATED EMISSION TEST RESULTS.....</b>	<b>13</b>
9.1. <i>LIMITS AND PROCEDURE .....</i>	13
9.1.1. <i>FUNDAMENTAL AND SPURIOUS EMISSIONS (0.15 – 30 MHz) .....</i>	16
9.1.2. <i>SPURIOUS EMISSION 0.009 TO 30 MHz.....</i>	18
9.1.3. <i>TX SPURIOUS EMISSION 30 TO 1000 MHz .....</i>	20
<b>10. AC MAINS LINE CONDUCTED EMISSIONS .....</b>	<b>22</b>
<b>11. FREQUENCY STABILITY .....</b>	<b>23</b>

# 1. ATTESTATION OF TEST RESULTS

**COMPANY NAME:** Honeywell Analytics Inc.  
**EUT DESCRIPTION:** NFC  
**MODEL NUMBER:** Vertex Edge Analyzer  
**SERIAL NUMBER:** Identical prototype;  
**DATE TESTED:** May 20, 2020 – Aug 06, 2020;

APPLICABLE STANDARDS	
STANDARD	TEST RESULTS
CFR 47 Part 15 Subpart C	Complies
ISED RSS-210 Issue 10	Complies
ISED RSS-GEN Issue 5	Complies

UL Korea, Ltd. tested the above equipment in accordance with the requirements set forth in the above standards. All indications of Pass/Fail in this report are opinions expressed by UL Korea, Ltd. based on interpretations and/or observations of test results. Measurement Uncertainties were not taken into account and are published for informational purposes only. The test results show that the equipment tested is capable of demonstrating compliance with the requirements as documented in this report.

**Note:** The results documented in this report apply only to the tested sample, under the conditions and modes of operation as described herein. This document may not be altered or revised in any way unless done so by UL Korea, Ltd. and all revisions are duly noted in the revisions section. Any alteration of this document not carried out by UL Korea, Ltd. will constitute fraud and shall nullify the document. This report must not be used by the client to claim product certification, approval, or endorsement by IAS, any agency of the Federal Government, or any agency of any government.

Approved & Released For  
UL Korea, Ltd. By:



CY Choi  
Suwon Lab Engineer  
UL Korea, Ltd.

Tested By:



Robby Lee  
Suwon Lab Engineer  
UL Korea, Ltd.

## 2. TEST METHODOLOGY

The tests documented in this report were performed in accordance with following methods.

1. FCC CFR 47 Part 2.
2. FCC CFR 47 Part 15.
3. ANSI C63.10-2013.
4. ISED RSS-210 Issue 10
5. ISED RSS-GEN Issue 5

## 3. FACILITIES AND ACCREDITATION

The test sites and measurement facilities used to collect data are located at 218 Maeyeong-ro, Yeongtong-gu, Suwon-si, Gyeonggi-do, 16675, Korea. Line conducted emissions are measured only at the 218 address. The following table identifies which facilities were utilized for radiated emission measurements documented in this report. Specific facilities are also identified in the test results sections.

218 Maeyeong-ro	
<input type="checkbox"/>	Chamber 1
<input type="checkbox"/>	Chamber 2
<input checked="" type="checkbox"/>	Chamber 3
<input checked="" type="checkbox"/>	10m Chamber

UL Korea, Ltd. is accredited by IAS, Laboratory Code TL-637. The full scope of accreditation can be viewed at <https://www.iasonline.org/wp-content/uploads/2017/05/TL-637-cert-New.pdf>.

## 4. CALIBRATION AND UNCERTAINTY

### 4.1. MEASURING INSTRUMENT CALIBRATION

The measuring equipment utilized to perform the tests documented in this report has been calibrated in accordance with the manufacturer's recommendations, and is traceable to recognized national standards.

### 4.2. SAMPLE CALCULATION

Where relevant, the following sample calculation is provided:

$$\begin{aligned} \text{Field Strength (dBuV/m)} &= \text{Measured Voltage (dBuV)} + \text{Antenna Factor (dB/m)} + \\ &\text{Cable Loss (dB)} - \text{Preamp Gain (dB)} \\ 36.5 \text{ dBuV} + 18.7 \text{ dB/m} + 0.6 \text{ dB} - 26.9 \text{ dB} &= 28.9 \text{ dBuV/m} \end{aligned}$$

### 4.3. MEASUREMENT UNCERTAINTY

Where relevant, the following measurement uncertainty levels have been estimated for tests performed on the apparatus:

PARAMETER	UNCERTAINTY
Conducted Disturbance, 0.15 to 30 MHz	2.35 dB
Radiated Disturbance, 9 kHz to 30 MHz	4.40 dB
Radiated Disturbance, 30 MHz to 1 GHz	3.49 dB

Uncertainty figures are valid to a confidence level of 95%.

### 4.4. DECISION RULE

Decision rule for statement(s) of conformity is based on Procedure 1, Clause 4.4.2 in IEC Guide 115:2007.

## 5. EQUIPMENT UNDER TEST

### 5.1. DESCRIPTION OF EUT

The EUT is a NFC. This test report addresses the DXX (NFC) operational mode.

### 5.2. MAXIMUM E-FIELD STRENGTH

The testing was performed at 3 meter. The transmitter maximum E-field at 30m distance is 6.21 dBuV/m which convert from 3 meter data.

### 5.3. WORST-CASE CONFIGURATION AND MODE

The NFC function was tested at its' fundamental and only operational frequency of 13.56 MHz. This EUT is a fixed device, tested at an axis when actually installed.

Radiated(fundamental level and spurious emissions) tests were performed both without reading a passive tag condition[test mode] and with reading a passive tag condition.

All test was performed a condition(ISO 15693-2).

## 5.4. DESCRIPTION OF TEST SETUP

### SUPPORT EQUIPMENT

Support Equipment List				
Description	Manufacturer	Model	Serial Number	FCC ID
Note book	HP	15-cs1010TU	5CD9354KDG	-

### I/O CABLE

I/O Cable List						
Cable No.	Port	# of identical ports	Connector Type	Cable Type	Cable Length(m)	Remarks
1	DC Power	1	Pin type	Unshielded	1m	N/A
2	LAN	1	RJ 45	Unshielded	1m	N/A



**SETUP DIAGRAM FOR TESTS (RADIATED TEST SETUP)**

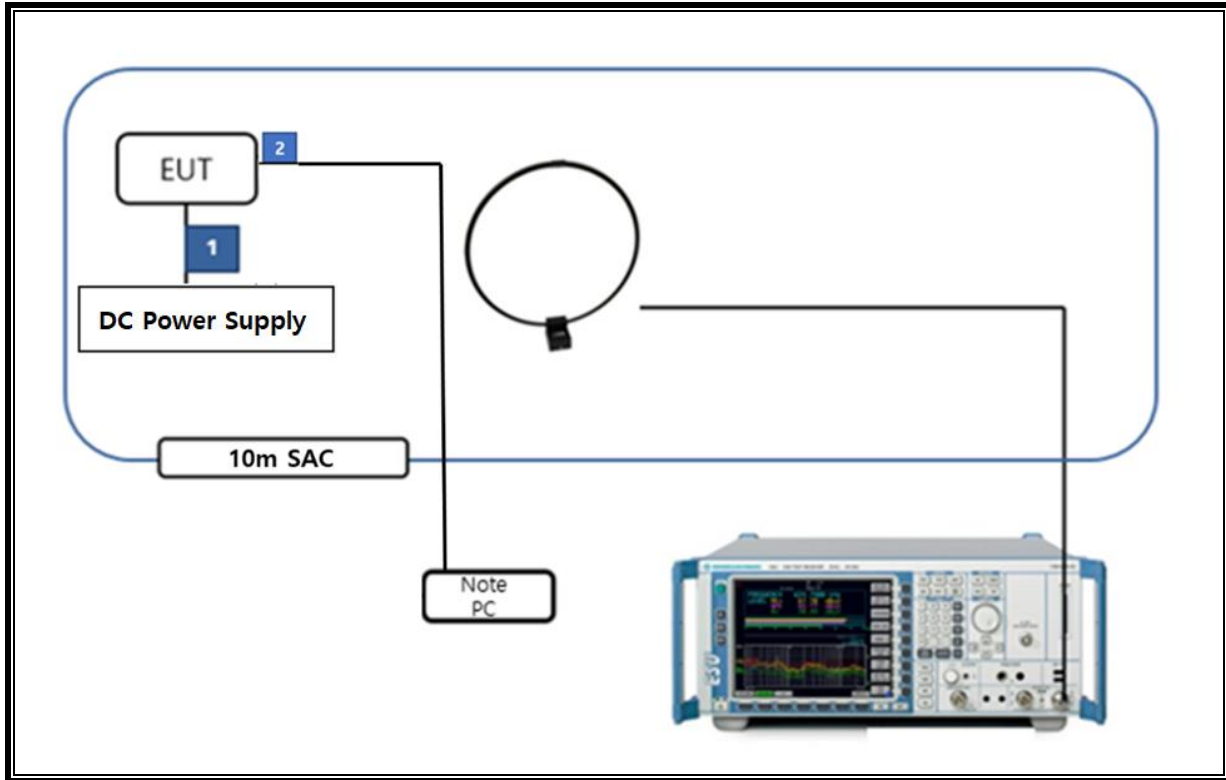

**Radiated Emissions Above 30 MHz:**

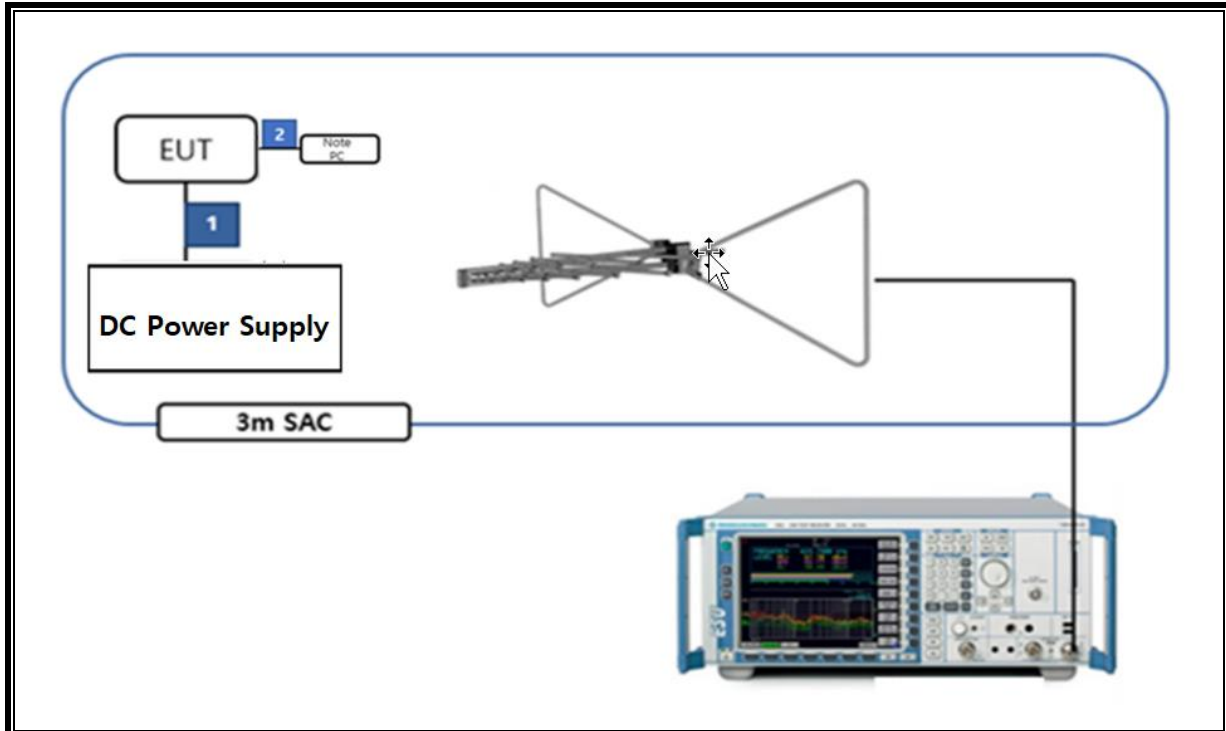

## 6. TEST AND MEASUREMENT EQUIPMENT

The following test and measurement equipment was utilized for the tests documented in this report:

Test Equipment List				
Description	Manufacturer	Model	S/N	Cal Due
Antenna, Bilog, 30MHz-1GHz	SCHWARZBECK	VULB9163	750	08-04-20
Antenna, Bilog, 30MHz-1GHz	SCHWARZBECK	VULB9163	749	08-04-20
Antenna, Bilog, 30MHz-1GHz	SCHWARZBECK	VULB9163	845	08-04-20
Preamplifier	ETS	3116C-PA	00168841	08-08-20
Preamplifier, 1000 MHz	Sonoma	310N	341282	08-05-20
Preamplifier, 1000 MHz	Sonoma	310N	351741	08-05-20
Preamplifier, 1000 MHz	Sonoma	310N	370599	08-05-20
Attenuator	WEINSCHTEL	54A-10	74560	08-08-20
EMI Test Receive, 40 GHz	R&S	ESU40	100439	08-06-20
EMI Test Receive, 40 GHz	R&S	ESU40	100457	08-06-20
EMI Test Receive, 44 GHz	R&S	ESW44	101590	08-05-20
EMI Test Receive, 3 GHz	R&S	ESR3	101832	08-05-20
EMI Test Receive, 3 GHz	R&S	ESR3	102592	06-28-20
Antenna, Loop, 9kHz-30MHz	R&S	HFH2-Z2	100418	10-02-21
Bias Unit	R&S	IN600	100974	09-30-20
Software				
Description	Manufacturer	Model	Version	
Radiated software	UL	UL EMC	Ver 9.5	
AC Line Conducted software	UL	UL EMC	Ver 9.5	
Radiated software	R&S	EMC32	10.60.10	

## 7. OCCUPIED BANDWIDTH

### LIMITS

None; for reporting purposes only.

### TEST PROCEDURE

The transmitter output is connected to the spectrum analyzer. The RBW is set to 1% to 5% of the 99 % bandwidth and to 1% of the span. The VBW is set to  $\geq 3$  times the RBW. The spectrum analyzer internal 99% bandwidth function is utilized.

### RESULTS

Frequency [MHz]	99% Bandwidth [kHz]
13.56	268.37

### 99% Occupied Bandwidth Plot

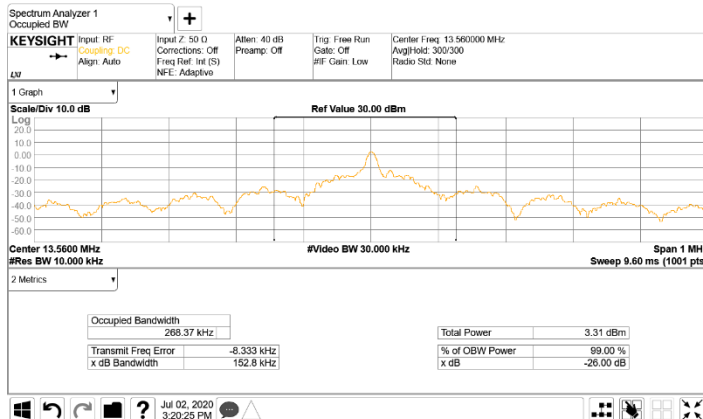

## 8. 20dB BANDWIDTH

### LIMITS

§15.215

(c) Intentional radiators operating under the alternative provisions to the general emission limits, as contained in §§15.217 through 15.257 and in subpart E of this part, must be designed to ensure that the 20 dB bandwidth of the emission, or whatever bandwidth may otherwise be specified in the specific rule section under which the equipment operates, is contained within the frequency band designated in the rule section under which the equipment is operated

§15.225

Operation within the band 13.110 – 14.010MHz

### TEST PROCEDURE

The spectrum analyzer connected receive antenna and the EUT placed on near the receive antenna. The RBW is set to 5KHz. The VBW is set to 3 times the RBW. The sweep time is coupled.

### RESULTS

Frequency [MHz]	20dB Bandwidth [kHz]
13.56	107.70

### 20dB Bandwidth Plot

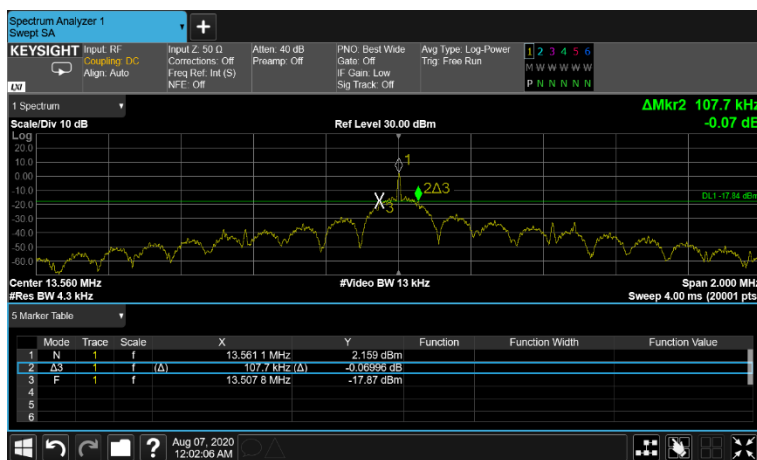

## 9. RADIATED EMISSION TEST RESULTS

### 9.1. LIMITS AND PROCEDURE

#### LIMIT

§15.225

(a) The field strength of any emissions within the band 13.553–13.567 MHz shall not exceed 15,848 microvolts/ meter at 30 meters.

(b) Within the bands 13.410–13.553 MHz and 13.567–13.710 MHz, the field strength of any emissions shall not exceed 334 microvolts/meter at 30 meters.

(c) Within the bands 13.110–13.410 MHz and 13.710–14.010 MHz the field strength of any emissions shall not exceed 106 microvolts/meter at 30 meters.

(d) The field strength of any emissions appearing outside of the 13.110– 14.010 MHz and shall not exceed the general radiated emission limits in § 15.209 as follows:

§15.209 (a) Except as provided elsewhere in this subpart, the emissions from an intentional radiator shall not exceed the field strength levels specified in the following table:

Limits for radiated disturbance of an intentional radiator		
Frequency range (MHz)	Limits (µV/m)	Measurement Distance (m)
0.009 – 0.490	2400 / F (kHz)	300
0.490 – 1.705	24000 / F (kHz)	30
1.705 – 30.0	30	30
30 – 88	100**	3
88 - 216	150**	3
216 – 960	200**	3
Above 960	500	3

\*\* Except as provided in paragraph (g), fundamental emissions from intentional radiators operating under this section shall not be located in the frequency bands 54-72 MHz, 76-88 MHz, 174-216 MHz or 470-806 MHz. However, operation within these frequency bands is permitted under other sections of this part, e.g. §§ 15.231 and 15.241.

§15.209 (b) In the emission table above, the tighter limit applies at the band edges.

Formula for converting the filed strength from uV/m to dBuV/m is:

Limit (dBuV/m) = 20 log limit (uV/m)

In addition:

§15.209 (d) The emission limits shown the above table are based on measurements employing a CISPR quasi-peak detector except for the frequency bands 9-90 kHz, 110-490 kHz and above 1000 MHz. Radiated emissions limits in these three bands are based on measurements employing an average detector.

§15.209 (d) The provisions in §§ 15.225, measuring emissions at distances other than the distances specified in the above table, determining the frequency range over which radiated emissions are to be measured, and limiting peak emissions apply to all devices operated under this part.

IC RSS-210 B.6  
 IC RSS-GEN Clause 8.9 and 8.10

The field strength of any emission shall not exceed the following limits:

15.848 mV/m (84 dBµV/m) at 30 m, within the band 13.553-13.567 MHz;  
 334 µV/m (50.5 dBµV/m) at 30 m, within the bands 13.410-13.553 MHz and 13.567-13.710 MHz;  
 106 µV/m (40.5 dBµV/m) at 30 m, within the bands 13.110-13.410 MHz and 13.710-14.010 MHz;  
 and RSS-Gen general field strength limits for frequencies outside the band 13.110-14.010 MHz.

Frequency (MHz)	Field strength (µV/m at 3 m)
30 – 88	100
88 – 216	150
216 – 960	200
Above 960	500

Frequency (MHz)	Magnetic field strength (H-Field) (µA/m)	Measurement Distance (m)
0.009–0.490 <sup>Note 1</sup>	6.37/F (F in kHz)	300
0.490–1.705	63.7/F (F in kHz)	30
1.705–30.0	0.08	30
Note 1: The emission limits for the ranges 9-90 kHz and 110-490 kHz are based on measurements employing a linear average detector.		

Note: The limits for spurious emissions below 30 MHz in RSS GEN Section 8.9 Table 6 are given in dBuA/m while the FCC Part 15.209(a) limits are expressed in dBuV/m. Using the free space impedance of 377Ω to convert between electric and magnetic field strength (a factor of 51.5dB in logarithmic units) the two sets of limits are equivalent and therefore a measured value of X dBuV/m shown in the plots and tables is equal to a magnetic field strength of (X - 51.5) dBuA/m and the margin of that emission relative to the RSS GEN limit (FCC 15.209 limit – 51.5) dBuA/m would be the same as the margin to the FCC limit detailed in those plots/tables.

## **TEST PROCEDURE**

ANSI C63.10-2013

The EUT is an intentional radiator that incorporates a digital device. The highest fundamental frequency generated or used in the device is 13.56 MHz. The frequency range was investigated from 0.15 MHz to the 10<sup>th</sup> harmonic of the highest fundamental frequency, or 1000 MHz, whichever is greater (1000MHz).

Test result (dBuV/m) = Reading Value (dBuV) + Correction Factor (dB/m)

Correction Factor (dB/m) = Antenna Factor (dB/m) + Cable Loss + Distance Correction Factor (dB)

Distance Correction Factor:

3m vs 300m conversion factor =  $40\log(300/3) = -80$  dB

3m vs 30m conversion factor =  $40\log(30/3) = -40$  dB

## **RESULTS**

No non-compliance noted:

### 9.1.1. FUNDAMENTAL AND SPURIOUS EMISSIONS (0.15 – 30 MHz)

Face On

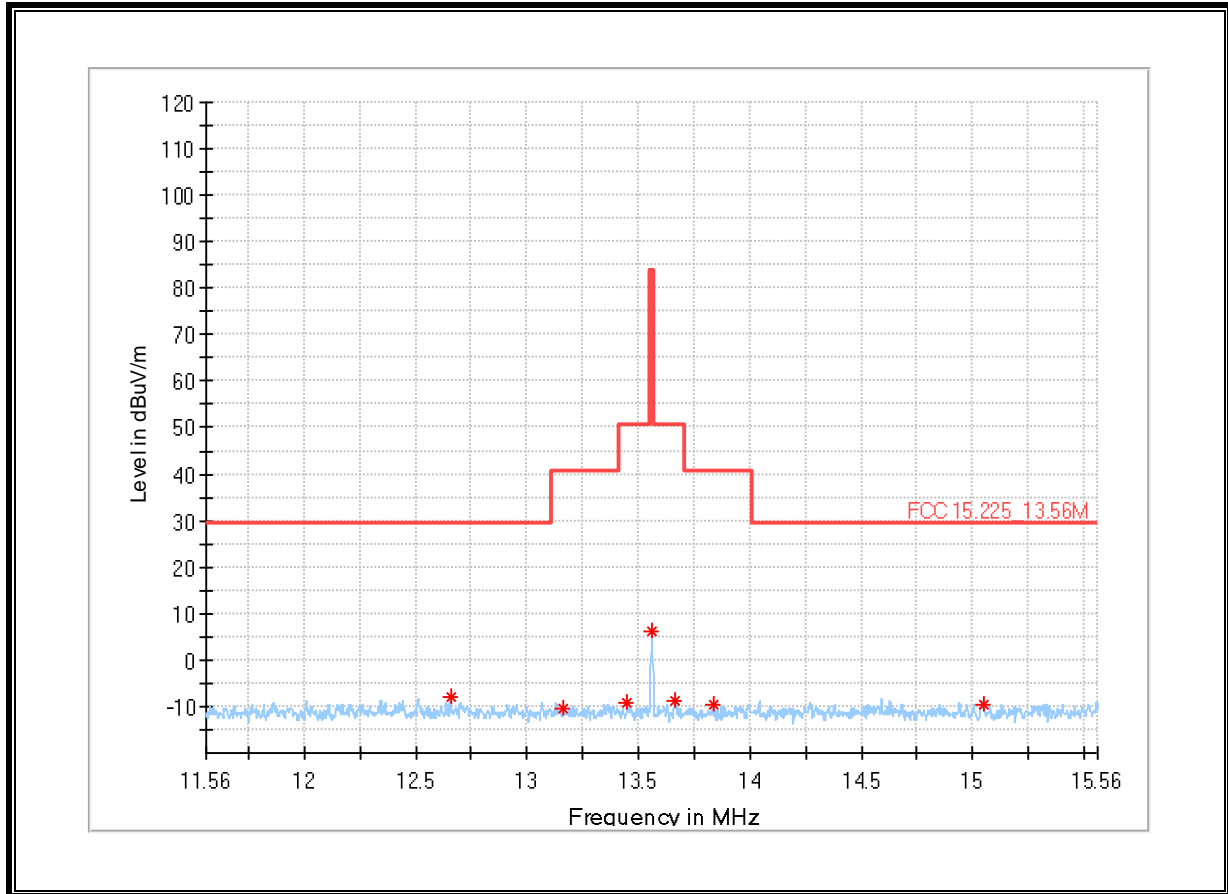

#### Critical\_Freqs

Frequency (MHz)	MaxPeak (dBuV/m)	Limit (dBuV/m)	Margin (dB)	Corr. (dB/m)
12.658000	-8.16	29.51	37.67	-19.2
13.164000	-10.34	40.51	50.85	-19.2
13.450000	-9.29	50.50	59.79	-19.2
13.560000	6.21	84.00	77.79	-19.2
13.668000	-8.93	50.50	59.43	-19.2
13.834000	-9.46	40.50	49.96	-19.1
15.048000	-9.50	29.50	39.00	-19.1



Face Off

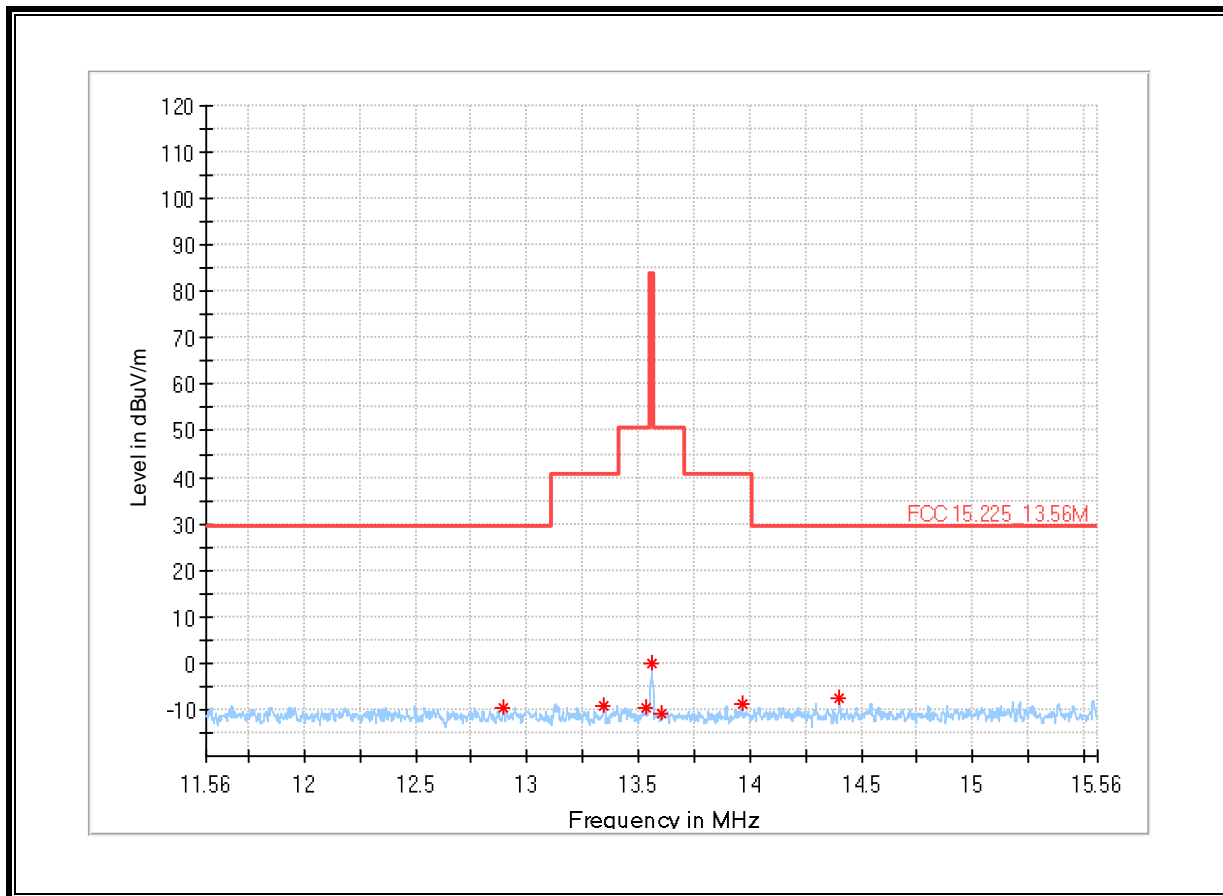

**Critical\_Freqs**

Frequency (MHz)	MaxPeak (dBuV/m)	Limit (dBuV/m)	Margin (dB)	Corr. (dB/m)
12.894000	-9.48	29.51	38.98	-19.2
13.346000	-9.27	40.50	49.77	-19.2
13.532000	-9.64	50.50	60.14	-19.2
13.558000	-0.04	84.00	84.04	-19.2
13.600000	-10.92	50.50	61.42	-19.2
13.964000	-8.68	40.50	49.18	-19.1
14.400000	-7.52	29.50	37.02	-19.1

Note 1 : Although these tests were performed other than open filed test site, adequate comparison measurements were confirmed against 30 m open are test site. Therefore sufficient tests were made to demonstrate that the alternative site produces results that correlate with the ones of tests made in an open field based on KDB 414788.

Note 2: Radiated test were investigated with three receiving antenna axes: Face-on, Face-off and horizontal (parallel to the ground plane) and the worse orientations of Face-on and Face-off were set for final test.

### 9.1.2. SPURIOUS EMISSION 0.009 TO 30 MHz

Face On

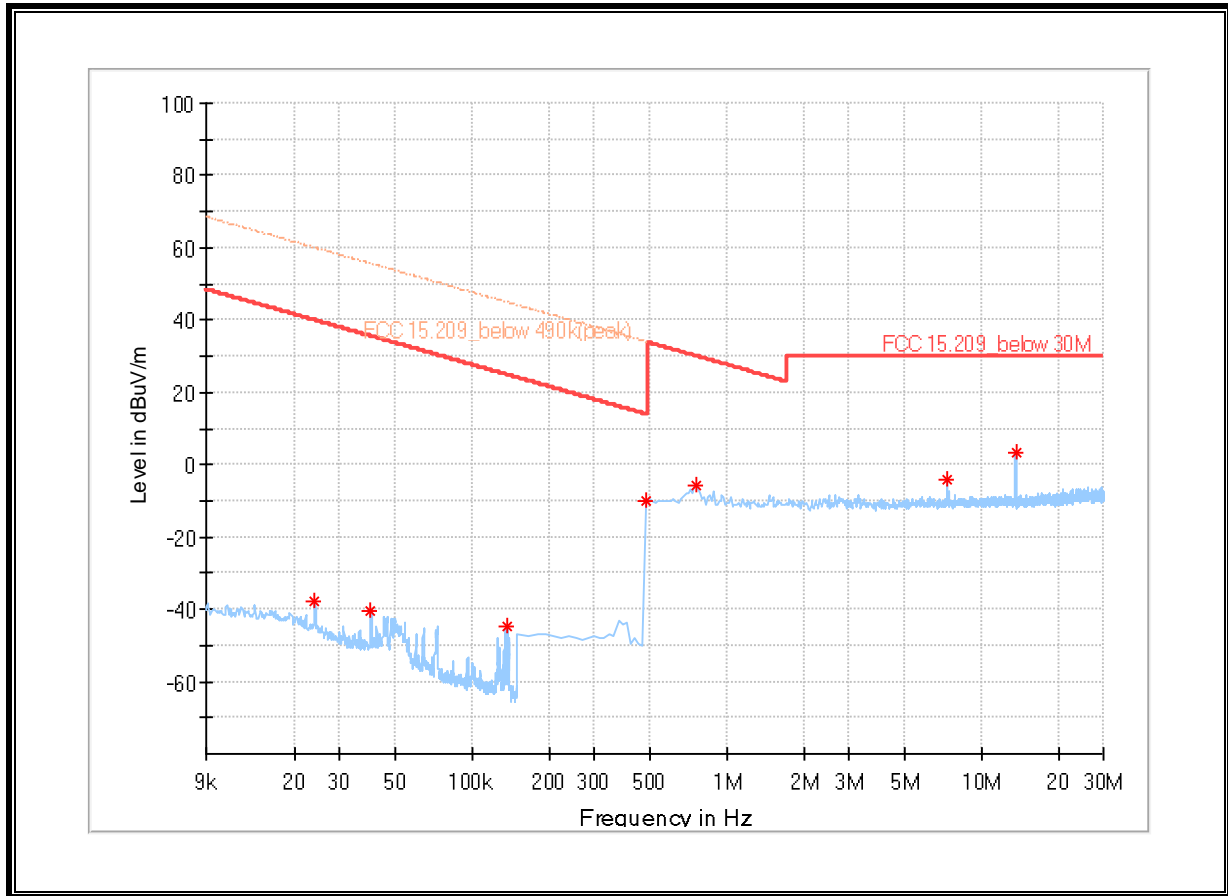

### Critical\_Freqs

Frequency (MHz)	MaxPeak (dBuV/m)	Limit (dBuV/m)	Margin (dB)	Bandwidth (kHz)	Height (cm)	Pol	Azimuth (deg)	Corr. (dB/m)
0.023962	-37.98	40.00	77.98	0.200	100.0	H	70.0	-59.6
0.039942	-40.74	35.56	76.30	0.200	100.0	H	11.0	-59.5
0.136370	-44.83	24.90	69.74	0.200	100.0	H	189.0	-59.6
0.478350	-9.82	14.01	23.83	9.000	100.0	H	309.0	-19.6
0.761925	-5.88	29.98	35.86	9.000	100.0	H	224.0	-19.6
7.314000	-4.37	30.00	34.37	9.000	100.0	H	51.0	-19.4
13.567575*	3.44	84.00	80.56	9.000	100.0	H	129.0	-19.2

\* Fundamental

Face Off

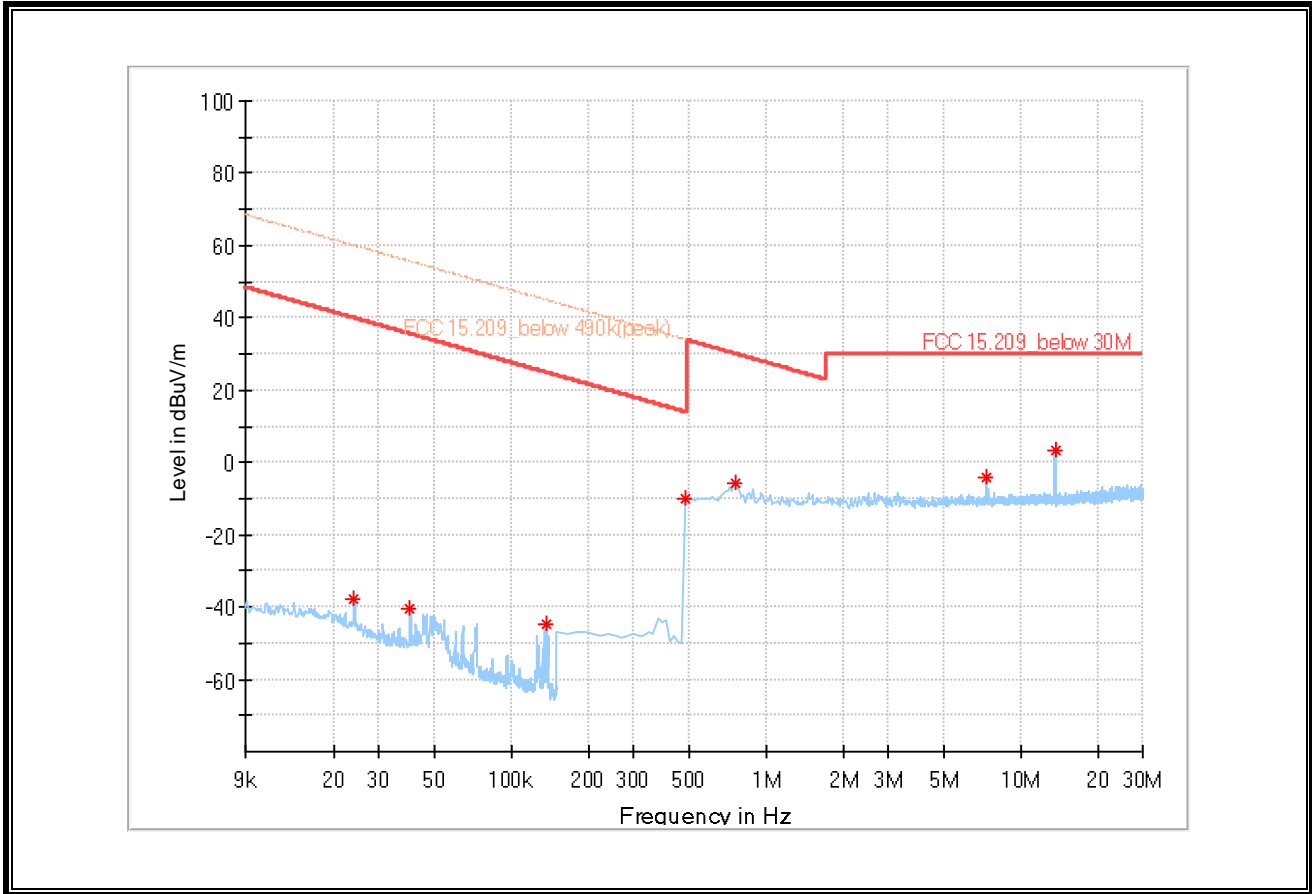

Critical\_Freqs

Frequency (MHz)	MaxPeak (dBuV/m)	Limit (dBuV/m)	Margin (dB)	Bandwidth (kHz)	Height (cm)	Pol	Azimuth (deg)	Corr. (dB/m)
0.024040	-38.22	39.97	78.19	0.200	100.0	H	358.0	-59.6
0.039942	-42.50	35.56	78.07	0.200	100.0	H	142.0	-59.5
0.135900	-44.43	24.93	69.36	0.200	100.0	H	4.0	-59.6
0.478350	-8.11	14.01	22.12	9.000	100.0	H	65.0	-19.6
0.747000	-6.04	30.15	36.19	9.000	100.0	H	26.0	-19.6
7.314000	-0.51	30.00	30.51	9.000	100.0	H	163.0	-19.4
13.567575*	0.66	84.00	83.34	9.000	100.0	H	173.0	-19.2

\* Fundamental

Note 1: Radiated test were investigated with three receiving antenna axes: Face-on, Face-off and horizontal (parallel to the ground plane) and the worse orientations of Face-on and Face-off were set for final test.

### 9.1.3. TX SPURIOUS EMISSION 30 TO 1000 MHz

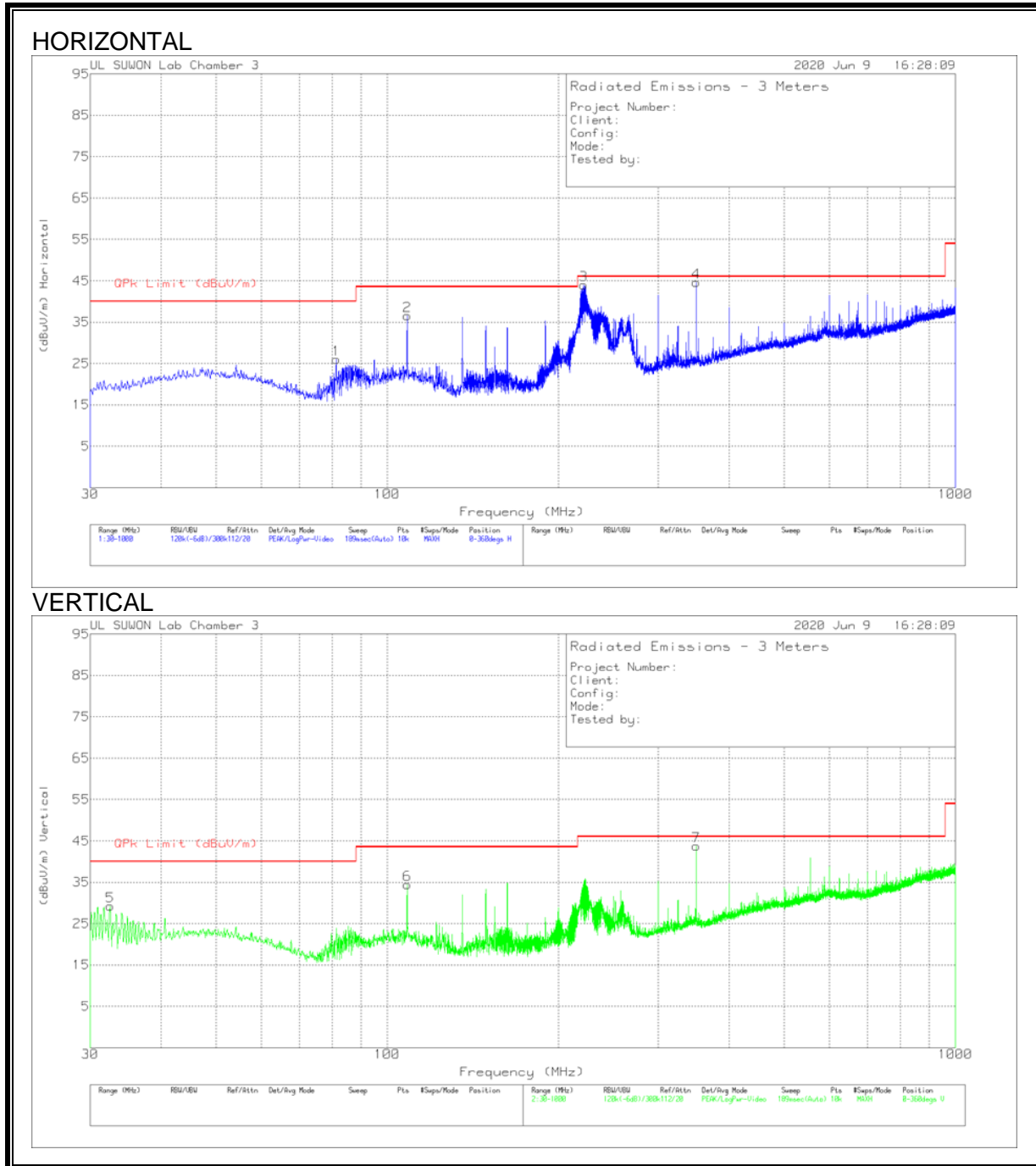

Trace Markers

Marker	Frequency (MHz)	Meter Reading (dBuV)	Det	VULB9163-845	Below_1G[dB]	Corrected Reading (dBuV/m)	QPk Limit (dBuV/m)	Margin (dB)	Azimuth (Degs)	Height (cm)	Polarity
1	81.3183	44.57	Pk	13.2	-31.8	25.97	40	-14.03	0-360	200	H
2	108.3841	50.74	Pk	17.5	-31.7	36.54	43.52	-6.98	0-360	300	H
3	221.5948	57.84	Pk	17.3	-31.1	44.04	46.02	-1.98	0-360	100	H
4	349.939	54.28	Pk	21	-30.6	44.68	46.02	-1.34	0-360	200	H
5	32.5223	45.07	Pk	16.5	-32.3	29.27	40	-10.73	0-360	100	V
6	108.3841	48.61	Pk	17.5	-31.7	34.41	43.52	-9.11	0-360	100	V
7	349.939	53.4	Pk	21	-30.6	43.8	46.02	-2.22	0-360	100	V

Pk - Peak detector

Note: These emissions are digital signal.

## 10. AC MAINS LINE CONDUCTED EMISSIONS

### LIMITS

§15.207

(a) Except as shown in paragraphs (b) and (c) of this section, for an intentional radiator that is designed to be connected to the public utility (AC) power line, the radio frequency voltage that is conducted back onto the AC power line on any frequency or frequencies, within the band 150 kHz to 30 MHz, shall not exceed the limits in the following table, as measured using a 50μH/50 ohms line impedance stabilization network (LISN). Compliance with the provisions of this paragraph shall be based on the measurement of the radio frequency voltage between each power line and ground at the power terminal. The lower limit applies at the band edges.

Frequency range (MHz)	Limits (dBμV)	
	Quasi-peak	Average
0.15 to 0.50	66 to 56	56 to 46
0.50 to 5	56	46
5 to 30	60	50

Notes:  
 1. The lower limit shall apply at the transition frequencies  
 2. The limit decreases linearly with the logarithm of the frequency in the range 0.15 MHz to 0.50 MHz.

### TEST PROCEDURE

The EUT is placed on a non-conducting table 40 cm from the vertical ground plane and 80 cm above the horizontal ground plane. The EUT is configured in accordance with ANSI C63.10.

The receiver is set to a resolution bandwidth of 9 kHz. Peak detection is used unless otherwise noted as quasi-peak or average.

Line conducted data is recorded for both NEUTRAL and HOT lines.

### RESULTS

This EUT is only supplied by DC power.

## 11. FREQUENCY STABILITY

### LIMIT

§15.225 (e) The frequency tolerance of the carrier signal shall be maintained within  $\pm 0.01\%$  of the operating frequency, over a temperature variation of -20 degrees to +50 degrees C at normal supply voltage, and for a variation in the primary supply voltage from 85% to 115% of the rated supply voltage at a temperature of 20 degrees C. For battery operated equipment, the equipment tests shall be performed using a new battery.

### TEST PROCEDURE

ANSI C63.10 §6.8

### RESULTS

Reference Frequency: EUT Channel 13.56 MHz @ 20°C										
Limit: $\pm 100$ ppm = 1.356 kHz										
Power Supply (Vdc)	Envir. Temp (°C)	Frequency Deviation Measured with Time Elapse								
		Start Up (MHz)	Delta (ppm)	@ 2mins (MHz)	Delta (ppm)	@ 5mins (MHz)	Delta (ppm)	@ 10mins (MHz)	Delta (ppm)	Limit (ppm)
24.00	50	13.560609143	1.915	13.560610204	1.837	13.560611111	1.770	13.560613771	1.574	100
24.00	40	13.560610882	1.787	13.560613386	1.602	13.560613081	1.624	13.560612837	1.642	100
24.00	30	13.560614592	1.513	13.560616170	1.397	13.560611972	1.706	13.560613917	1.563	100
24.00	20	13.560635110	0	13.560626093	0.665	13.560625520	0.707	13.560625479	0.710	100
24.00	10	13.560638885	-0.278	13.560634219	0.066	13.560634259	0.063	13.560634907	0.015	100
24.00	0	13.560641036	-0.437	13.560641756	-0.490	13.560641665	-0.483	13.560641685	-0.485	100
24.00	-10	13.560629253	0.432	13.560635967	-0.063	13.560636081	-0.072	13.560635745	-0.047	100
24.00	-20	13.560537748	7.180	13.560626926	0.604	13.560626200	0.657	13.560626278	0.651	100
24.00	-30	13.560475557	11.766	13.560519964	8.491	13.560520261	8.469	13.560520591	8.445	100

Reference Frequency: EUT Channel 13.56 MHz @ 20°C										
Limit: $\pm 100$ ppm = 1.356 kHz										
Power Supply (Vdc)	Envir. Temp (°C)	Frequency Deviation Measured with Time Elapse								
		Start Up (MHz)	Delta (ppm)	@ 2mins (MHz)	Delta (ppm)	@ 5mins (MHz)	Delta (ppm)	@ 10mins (MHz)	Delta (ppm)	Limit (ppm)
24.00	20	13.560635110	0	13.560626093	0.665	13.560625520	0.707	13.560625479	0.710	100
27.60	20	13.560631439	0.271	13.560626306	0.649	13.560625745	-0.017	13.560625754	0.690	100
20.40	20	13.560633645	0.108	13.560628116	0.516	13.560625893	-0.028	13.560625869	0.681	100

No non-compliance noted.

## END OF TEST REPORT