

FCC TEST REPORT
for
High-Flying Electronics Technology Co., Ltd.

Zigbee Module
Model No.: HF-Z100

Prepared for : High-Flying Electronics Technology Co., Ltd.
Address : Room 1002, Building 1, No.3000, Longdong Avenue, Pudong
New Area, Shanghai, China, 201203

Prepared By : Shenzhen Anbotek Compliance Laboratory Limited
Address : 1/F., Building 1, SEC Industrial Park, No.0409 Qianhai Road,
Nanshan District, Shenzhen, Guangdong, China
Tel: (86) 755-26066544
Fax: (86) 755-26014772

Report Number : R011406345E
Date of Test : Jun. 16~ 30, 2014
Date of Report : Jul. 12, 2014

TABLE OF CONTENT

Description	Page
Test Report	
1. GENERAL INFORMATION	4
1.1. Description of Device (EUT)	4
1.2. Auxiliary Equipment Used during Test	5
1.3. Description of Test Facility	5
1.4. Measurement Uncertainty	5
2. TEST METHODOLOGY	6
2.1. Summary of Test Results	6
2.2. Description of Test Modes	6
3. CONDUCTED EMISSION TEST	7
3.1. Block Diagram of Test Setup	7
3.2. Power Line Conducted Emission Measurement Limits (15.207)	7
3.3. Configuration of EUT on Measurement	7
3.4. Operating Condition of EUT	7
3.5. Test Procedure	8
3.6. Test equipment	8
3.7. Power Line Conducted Emission Measurement Results	8
4. FCC PART 15.247 REQUIREMENTS FOR DSSS & OFDM MODULATION	11
4.1 Test Setup	11
4.2 6dB Bandwidth	11
4.3. Maximum Peak output power test	14
4.4. Band Edges Measurement	17
4.5. Peak Power Spectral Density	20
4.6. Radiated Emissions	23
5. PHOTOGRAPH	31
5.1. Photo of Conducted Emission Measurement	31
5.2. Photo of Radiation Emission Test	31
APPENDIX I (EXTERNAL PHOTOS)	33
APPENDIX II (INTERNAL PHOTOS)	35

TEST REPORT

Applicant : High-Flying Electronics Technology Co., Ltd.
Manufacturer : High-Flying Electronics Technology Co., Ltd.
EUT : Zigbee Module
Model No. : HF-Z100
Serial No. : N.A.
Trade Mark : High-Flying
Rating : DC 3.3V±5%, 170mA-300mA

Measurement Procedure Used:
FCC Part15 Subpart C, Paragraph 15.247

The device described above is tested by Shenzhen Anbotek Compliance Laboratory Limited to determine the maximum emission levels emanating from the device and the severe levels of the device can endure and its performance criterion. The measurement results are contained in this test report and Shenzhen Anbotek Compliance Laboratory Limited is assumed full of responsibility for the accuracy and completeness of these measurements. Also, this report shows that the EUT (Equipment Under Test) is technically compliant with the FCC Part 15 Subpart C requirements.

This report applies to above tested sample only and shall not be reproduced in part without written approval of Shenzhen Anbotek Compliance Laboratory Limited.

Date of Test : Jun. 16~ 30, 2014

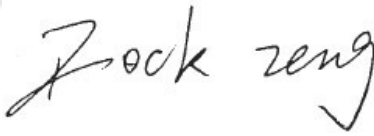
Prepared by : 
(Tested Engineer / Rock Zeng)

Reviewer : 
(Project Manager / Amy Ding)

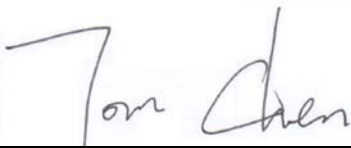
Approved & Authorized Signer : 
(Manager / Tom Chen)

1. GENERAL INFORMATION

1.1. Description of Device (EUT)

EUT : Zigbee Module

Model Number : HF-Z100

Test Power Supply : AC 120V/60Hz for adapter

Adapter : Model: FLD052-0501000-UH
Input: AC 100-240V, 50/60Hz, 0.15A Max.
Output: DC 5.0V, 1.0A

RF Transmission Frequency : Zigbee: 2405-2480MHz

No. of Channels : 16

Channel Space : 5MHz

Modulation : DSSS

Antenna Gain: : 0 dBi

Applicant : High-Flying Electronics Technology Co., Ltd.
Address : Room 1002, Building 1, No.3000, Longdong Avenue, Pudong New Area, Shanghai, China, 201203

Manufacturer : High-Flying Electronics Technology Co., Ltd.
Address : Room 1002, Building 1, No.3000, Longdong Avenue, Pudong New Area, Shanghai, China, 201203

Factory : High-Flying Electronics Technology Co., Ltd.
Address : Room 1002, Building 1, No.3000, Longdong Avenue, Pudong New Area, Shanghai, China, 201203

Date of receipt : Jun. 16, 2014

Date of Test : Jun. 16~ 30, 2014

1.2. Auxiliary Equipment Used during Test

N/A

1.3. Description of Test Facility

The test facility is recognized, certified, or accredited by the following organizations:

CNAS - LAB Code: L3503

Shenzhen Anbotek Compliance Laboratory Limited., Laboratory has been assessed and in compliance with CNAS/CL01: 2006 accreditation criteria for testing laboratories (identical to ISO/IEC 17025:2005 General Requirements) for the Competence of Testing Laboratories.

FCC-Registration No.: 752021

Shenzhen Anbotek Compliance Laboratory Limited, EMC Laboratory has been registered and fully described in a report filed with the (FCC) Federal Communications Commission. The acceptance letter from the FCC is maintained in our files. Registration 752021, July 10, 2013.

IC-Registration No.: 8058A-1

Shenzhen Anbotek Compliance Laboratory Limited., EMC Laboratory has been registered and fully described in a report filed with the (IC) Industry Canada. The acceptance letter from the IC is maintained in our files. Registration 8058A, February 22, 2013.

Test Location

All Emissions tests were performed at
Shenzhen Anbotek Compliance Laboratory Limited. at 1/F., Building 1, SEC Industrial Park, No.0409 Qianhai Road, Nanshan District, Shenzhen, Guangdong, China

1.4. Measurement Uncertainty

Radiation Uncertainty : Ur = 4.3dB

Conduction Uncertainty : Uc = 3.4dB

2. TEST METHODOLOGY

The tests documented in this report were performed in accordance with ANSI C63.4: 2009 and FCC Part 15, Paragraph 15.247.

2.1. Summary of Test Results

The EUT has been tested according to the following specifications:

Standard	Test Type	Result	Notes
FCC Part 15, Paragraph 15.107, 15.207	Conducted Emission Test	PASS	Complies
FCC Part 15, Paragraph 15.247(b)(1)	Peak Output Power	PASS	Complies
FCC Part 15, Paragraph 15.247(a)(2)	6dB Bandwidth	PASS	Complies
FCC Part 15, Paragraph 15.247(c)	100kHz Bandwidth of Frequency Band Edges	PASS	Complies
FCC Part 15, Paragraph 15.209(a)(f)	Spurious Emission	PASS	Complies
FCC Part 15, Paragraph 15.247(a)(1)	Frequency Separation	-	N/A
FCC Part 15, Paragraph 15.247(a)(1)(iii)	Number of Hopping Frequency	-	N/A
FCC Part 15, Paragraph 15.247(a)(1)(iii)	Time of Occupancy	-	N/A
FCC Part 15, Paragraph 15.247(c)	Peak Power Density	PASS	Complies

2.2. Description of Test Modes

The EUT has been tested under operating condition.

Software used to control the EUT for staying in continuous transmitting and receiving mode is programmed.

Channel	Frequency (MHz)	Channel	Frequency (MHz)	Channel	Frequency (MHz)
1	2405	7	2435	13	2465
2	2410	8	2440	14	2470
3	2415	9	2445	15	2475
4	2420	10	2450	16	2480
5	2425	11	2455	--	--
6	2430	12	2460		

Channel 1(2405MHz), Channel 8(2440MHz) and Channel 16(2480MHz) are chosen for the final testing.

3. Conducted Emission Test

3.1. Block Diagram of Test Setup

3.1.1. Block diagram of connection between the EUT and simulators

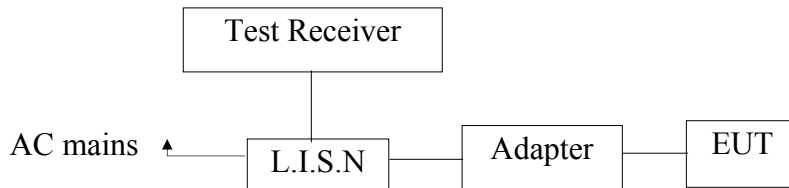

3.2. Power Line Conducted Emission Measurement Limits (15.207)

Frequency MHz	Limits dB(μV)	
	Quasi-peak Level	Average Level
0.15 ~ 0.50	66 ~ 56*	56 ~ 46*
0.50 ~ 5.00	56	46
5.00 ~ 30.00	60	50

- Notes: 1. *Decreasing linearly with logarithm of frequency.
2. The lower limit shall apply at the transition frequencies.

3.3. Configuration of EUT on Measurement

The following equipments are installed on Power Line Conducted Emission Measurement to meet the commission requirement and operating regulations in a manner which tends to maximize its emission characteristics in a normal application.

3.4. Operating Condition of EUT

- 3.4.1. Setup the EUT and simulator as shown as Section 3.1.
- 3.4.2. Turn on the power of all equipment.
- 3.4.3. Let the EUT work in test mode (ON) and measure it.

3.5. Test Procedure

The EUT system is connected to the power mains through a line impedance stabilization network (L.I.S.N.). This provides a 50ohm coupling impedance for the EUT system. Please refer the block diagram of the test setup and photographs. Both sides of AC line are checked to find out the maximum conducted emission. In order to find the maximum emission levels, the relative positions of equipment and all of the interface cables shall be changed according to FCC ANSI C63.4-2003 on Conducted Emission Measurement.

The bandwidth of test receiver (ESCI) set at 9KHz.

The frequency range from 150KHz to 30MHz is checked.

The test results are reported on Section 3.6.

3.6. Test equipment

Item	Equipment	Manufacturer	Model No.	Serial No.	Last Cal.	Cal. Interval
1.	Two-Line V-network	Rohde & Schwarz	ENV216	100055	Apr. 23, 2014	1 Year
2.	EMI Test Receiver	Rohde & Schwarz	ESCI	100627	Apr. 23, 2014	1 Year
3.	RF Switching Unit	Compliance Direction	RSU-M2	38303	Apr. 23, 2014	1 Year

3.7. Power Line Conducted Emission Measurement Results

PASS.

The frequency range from 150KHz to 30 MHz is investigated.

CONDUCTED EMISSION TEST DATA

Test Site: 1# Shielded Room
 Operating Condition: ON
 Test Specification: AC 120V/60Hz for Adapter
 Comment: Live Line
 Tem:25°C Hum:50%

SCAN TABLE: "Voltage (150K~30M) FIN"

Short Description: 150K-30M Disturbance Voltages

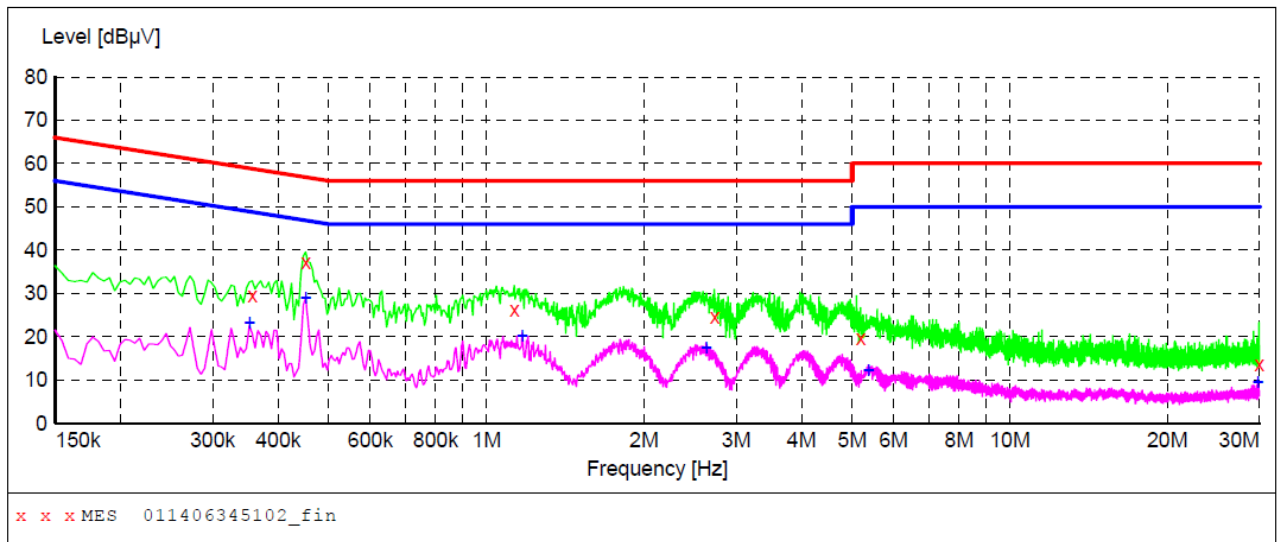

MEASUREMENT RESULT: "011406345102_fin"

6/19/2014 6:59PM

Frequency MHz	Level dBµV	Transd dB	Limit dBµV	Margin dB	Detector	Line	PE
0.357000	29.40	20.1	59	29.4	QP	L1	GND
0.451500	37.20	20.1	57	19.6	QP	L1	GND
1.130500	26.30	20.2	56	29.7	QP	L1	GND
2.728000	24.70	20.4	56	31.3	QP	L1	GND
5.189500	19.70	20.5	60	40.3	QP	L1	GND
29.957500	13.70	20.9	60	46.3	QP	L1	GND

MEASUREMENT RESULT: "011406345102_fin2"

6/19/2014 6:59PM

Frequency MHz	Level dBµV	Transd dB	Limit dBµV	Margin dB	Detector	Line	PE
0.352500	23.10	20.1	49	25.8	AV	L1	GND
0.451500	28.90	20.1	47	17.9	AV	L1	GND
1.171000	20.30	20.2	46	25.7	AV	L1	GND
2.629000	17.30	20.4	46	28.7	AV	L1	GND
5.369500	12.10	20.5	50	37.9	AV	L1	GND
29.777500	9.50	20.9	50	40.5	AV	L1	GND

CONDUCTED EMISSION TEST DATA

Test Site: 1# Shielded Room
 Operating Condition: ON
 Test Specification: AC 120V/60Hz for Adapter
 Comment: Neutral Line
 Tem:25°C Hum:50%

SCAN TABLE: "Voltage (150K~30M) FIN"

Short Description: 150K-30M Disturbance Voltages

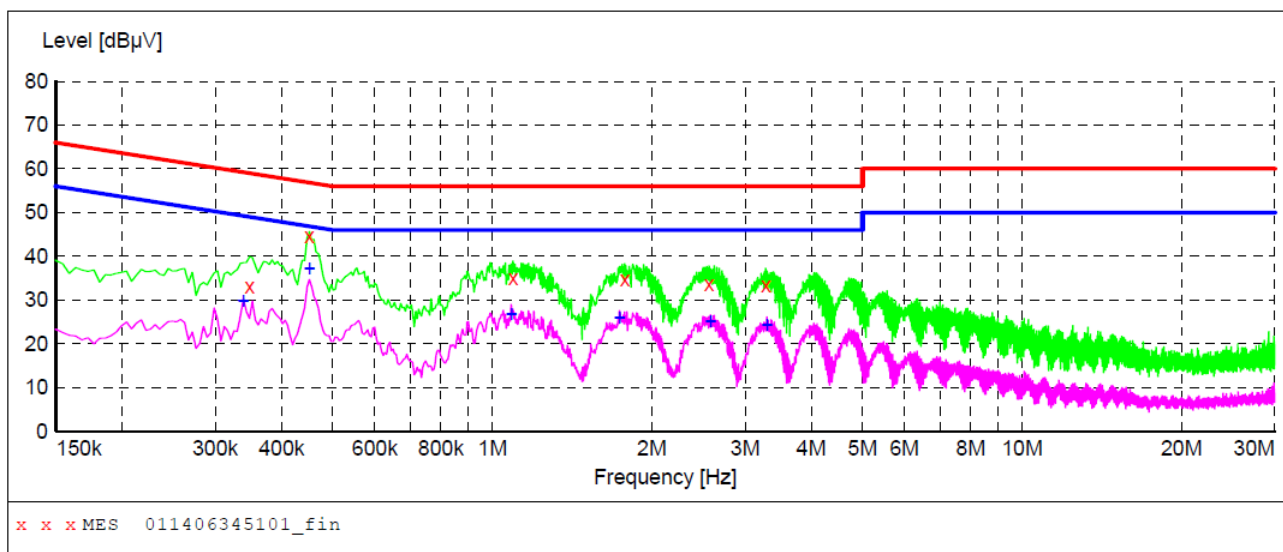

MEASUREMENT RESULT: "011406345101_fin"

6/19/2014 6:55PM

Frequency MHz	Level dBµV	Transd dB	Limit dBµV	Margin dB	Detector	Line	PE
0.348000	33.10	20.1	59	25.9	QP	N	GND
0.451500	44.50	20.1	57	12.3	QP	N	GND
1.094500	35.00	20.2	56	21.0	QP	N	GND
1.778500	34.60	20.3	56	21.4	QP	N	GND
2.566000	33.60	20.4	56	22.4	QP	N	GND
3.281500	33.20	20.4	56	22.8	QP	N	GND

MEASUREMENT RESULT: "011406345101_fin2"

6/19/2014 6:55PM

Frequency MHz	Level dBµV	Transd dB	Limit dBµV	Margin dB	Detector	Line	PE
0.339000	29.70	20.1	49	19.5	AV	N	GND
0.451500	37.20	20.1	47	9.6	AV	N	GND
1.085500	26.80	20.2	46	19.2	AV	N	GND
1.738000	25.80	20.3	46	20.2	AV	N	GND
2.584000	25.10	20.4	46	20.9	AV	N	GND
3.299500	24.20	20.4	46	21.8	AV	N	GND

4. FCC Part 15.247 Requirements for DSSS & OFDM Modulation

4.1 Test Setup

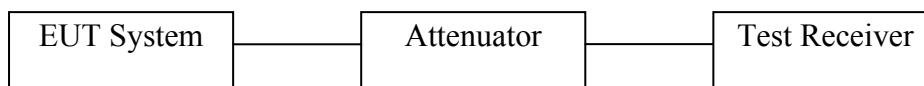

4.2 6dB Bandwidth

a. Limit

For the direct sequence systems, the minimum 6dB bandwidth shall be at least 500kHz.

b. Test Procedure

1. Place the EUT on the table and set it in the transmitting mode.
2. Remove the antenna from the EUT and then connect a low loss RF cable from the antenna port to the spectrum analyzer.
3. Set the spectrum analyzer as:
 RBW = 100kHz, VBW \geq 3*RBW = 300kHz,
 Detector= Peak
 Trace mode= Max hold.
 Sweep- auto couple.
4. Mark the peak frequency and -6dB (upper and lower) frequency.
5. Repeat until all the rest channels are investigated.

c. Test Setup See 4.1

d. Test Equipment

Item	Equipment	Manufacturer	Model No.	Serial No.	Last Cal.	Cal. Interval
1.	Spectrum Analysis	Agilent	E4407B	US39390582	Aug. 09, 2013	1 Year
2.	Preamplifier	Instruments corporation	EMC011830	980100	Aug. 09, 2013	1 Year
3.	EMI Test Receiver	Rohde & Schwarz	ESPI	101604	Apr. 23, 2014	1 Year
4.	Double Ridged Horn Antenna	Instruments corporation	GTH-0118	351600	Aug. 09, 2013	3 Year
5.	EMI Test Software EZ-EMC	SHURPLE	N/A	N/A	N/A	N/A

e. Test Results

Pass.

f. Test Data

Test mode: IEEE 802.15.4

Channel	Frequency (MHz)	Bandwidth (kHz)	Limit (kHz)	Results
Low	2405	1606		Pass
Mid	2440	1580	>500	Pass
High	2480	1620		Pass

Test Plots See the following page.

2405MHz:

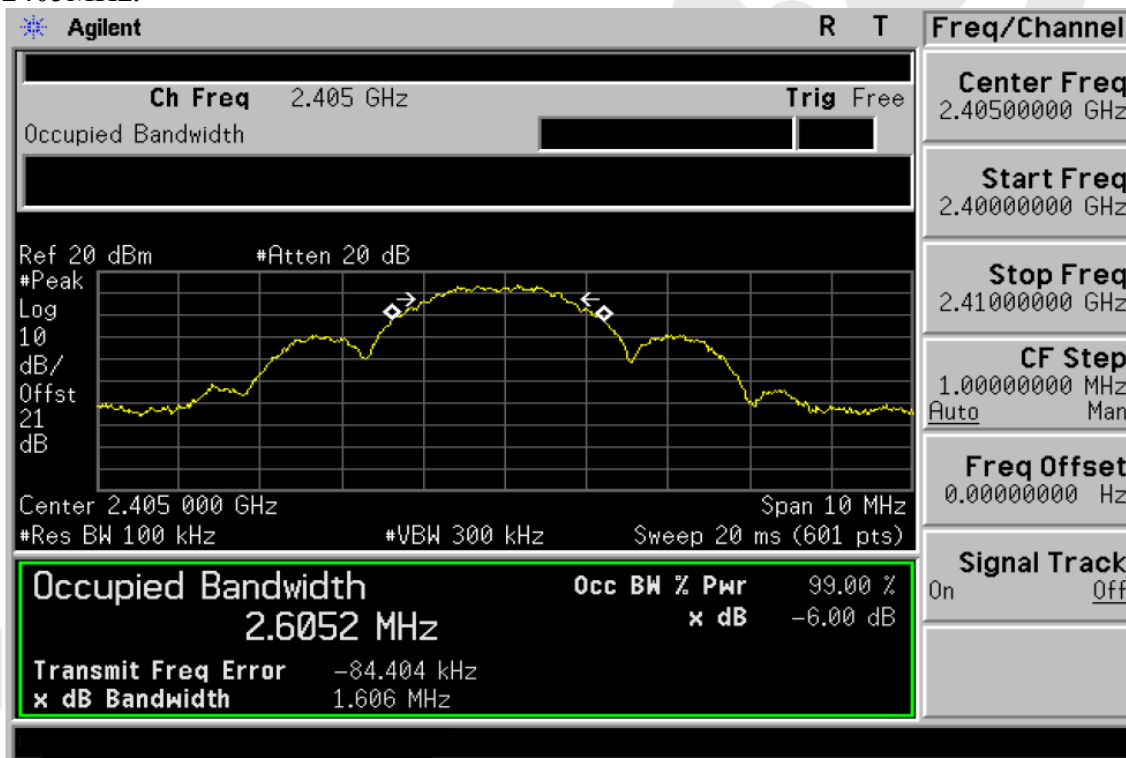

2440MHz:

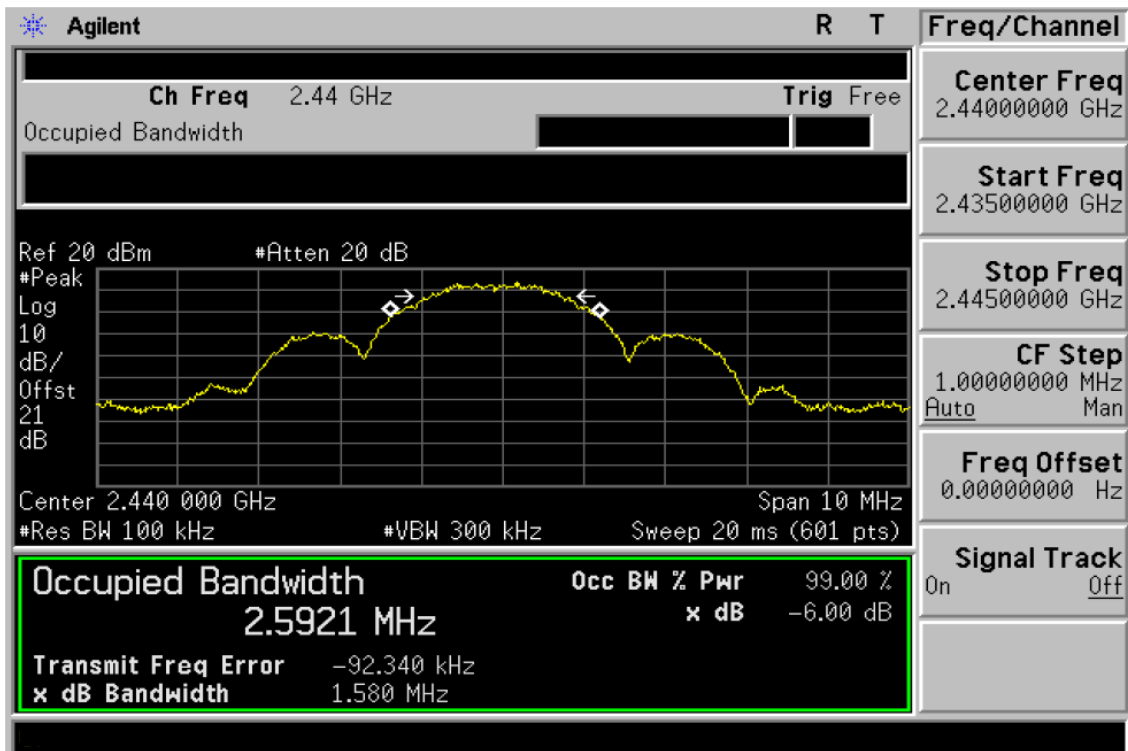

2480MHz:

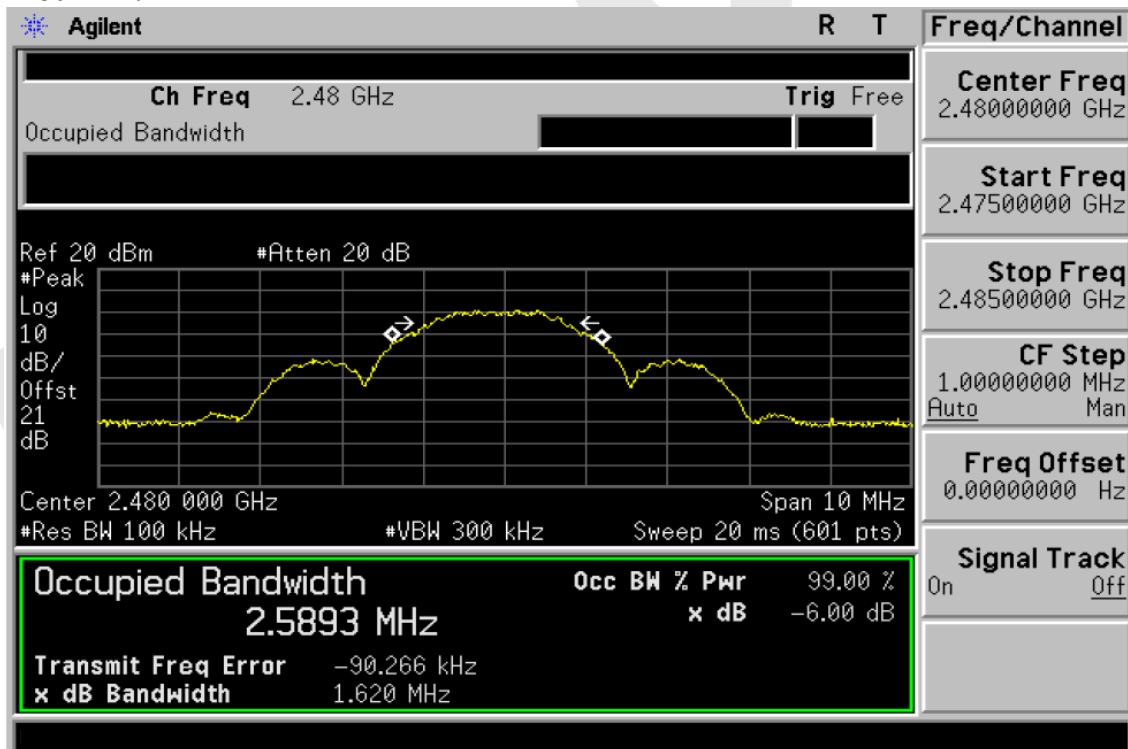

4.3. Maximum Peak output power test

a. Limit

The maximum peak output power of the intentional radiator shall not exceed the following:

1. For systems using digital modulation in the bands of 902-928 MHz, 2400-2483.5 MHz, and 5725-5850 MHz: 1 watt (30dBm).
2. Except as shown in paragraphs (b)(3) (i), (ii) and (iii) of this section, if transmitting antenna of directional gain greater than 6 dBi are used the peak output power from the intentional radiator shall be reduced below the stated values in paragraphs (b)(1) or (b)(2) of this section, as appropriate, by the amount in dB that the directional gain of the antenna exceeds 6 dBi.

b. Configuration of Measurement

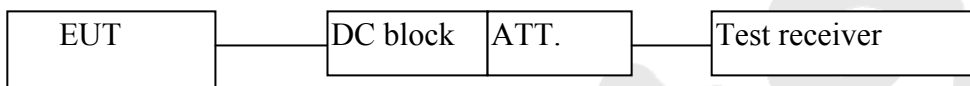

c. Data Rates

IEEE802.11b: Channel 1(2412MHz), Channel 6(2437MHz) and Channel 11(2462MHz) with 1 Mbps data rate (worst case) are chosen for the final testing.

IEEE802.11g: Channel 1(2412MHz), Channel 6(2437MHz) and Channel 11(2462MHz) with 6 Mbps data rate (the worst case) are chosen for the final testing.

IEEE802.11n (HT20: Channel 1(2412MHz), Channel 6(2437MHz) and Channel 11(2462MHz) with 6.5Mbps data rate (the worst case) are chosen for the final testing.

IEEE802.11n (HT40: Channel 3(2422MHz), Channel 6(2437MHz) and Channel 9(2452MHz) with 13.5Mbps data rate (the worst case) are chosen for the final testing.

d. Test Procedure

This test was according the kDB 558074 9.1.2:

1. This procedure may be used when the maximum available RBW of the measurement instrument is less than the DTS bandwidth.
2. Set the RBW = 1 MHz.
3. Set the VBW $\geq 3 * RBW = 3$ MHz.
4. Set the span $\geq 1.5 * DTS$ bandwidth.
5. Detector = peak.
6. Sweep time = auto couple.
7. Trace mode = max hold.
8. Allow trace to fully stabilize.
9. Use the instrument's band/channel power measurement function with the band limits set equal to the DTS bandwidth edges (for some instruments, this may require a manual override to select peak detector). If the instrument does not have a band power function, sum the spectrum levels (in linear power units) at intervals equal to the RBW extending across the DTS bandwidth.

e. Test Equipment

Same as the equipment listed in 4.2.

f. Test Results

Pass.

g. Test Data

Test mode: IEEE 802.15.4

Channel	Frequency (MHz)	Maximum transmit power (dBm)	Limit		Result
			(dBm)	(watts)	
Low	2405	9.88	30	1	Pass
Mid	2440	10.67			Pass
High	2480	11.98			Pass

2405MHz:

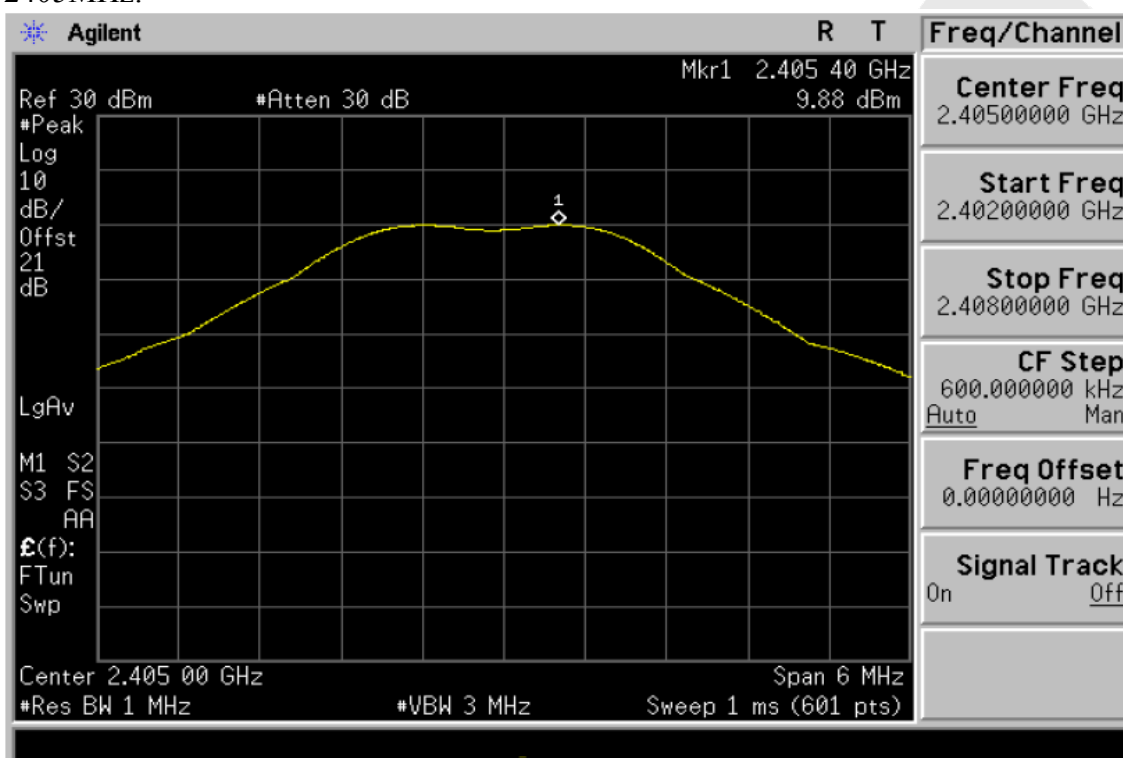

2440MHz:

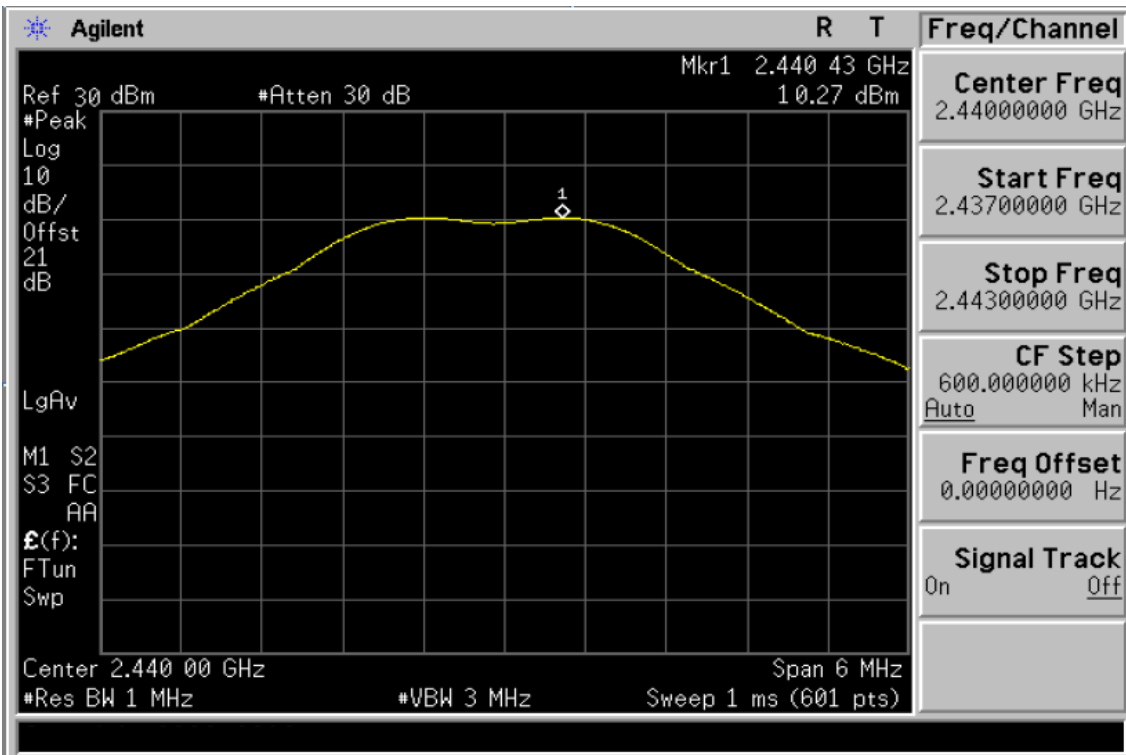

2480MHz:

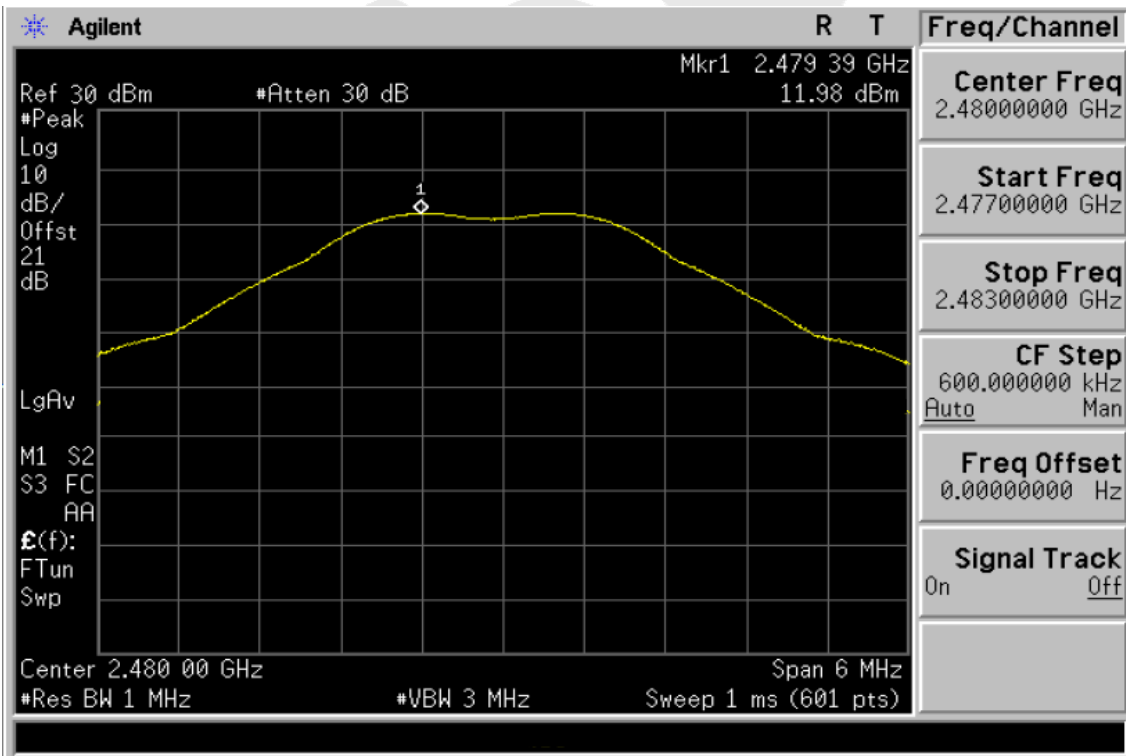

4.4. Band Edges Measurement

a. Limit

According to §15.247(c), in any 100 kHz bandwidth outside the frequency bands in which the spread spectrum intentional radiator is operating, the radio frequency power that is produced by the intentional radiator shall be at least 20dB below that in the 100kHz bandwidth within the band that contains the highest level of the desired power. In addition, radiated emissions which fall in the restricted bands, as defined in §15.205(a), must also comply with the radiated emission limits specified in §15.209(a).

b. Test Procedure

1. Conducted Method:

- 1) Set RBW=100KHz, VBW=300KHz
- 2) Detector=peak
- 3) Sweep time= auto
- 4) Trace mode=max hold.

2. Radiated Method:

- 1) The EUT is placed on a turntable, which is 0.8m above the ground plane.
- 2) The turntable shall be rotated for 360 degrees to determine the position of maximum emission level.
- 3) EUT is set 3m away from the receiving antenna, which is varied from 1m to 4m to find out the highest emission.
- 4) Peak detector: RBW=1MHz, VBW=3MHz, SWT=AUTO
Average detector: RBW=1MHz, VBW=10Hz, SWT=AUTO
The EUT is tested in 9*6*6 Chamber.
- 5) Repeat the procedures until all the PEAK and AVERAGE versus POLARIZATION are measured.

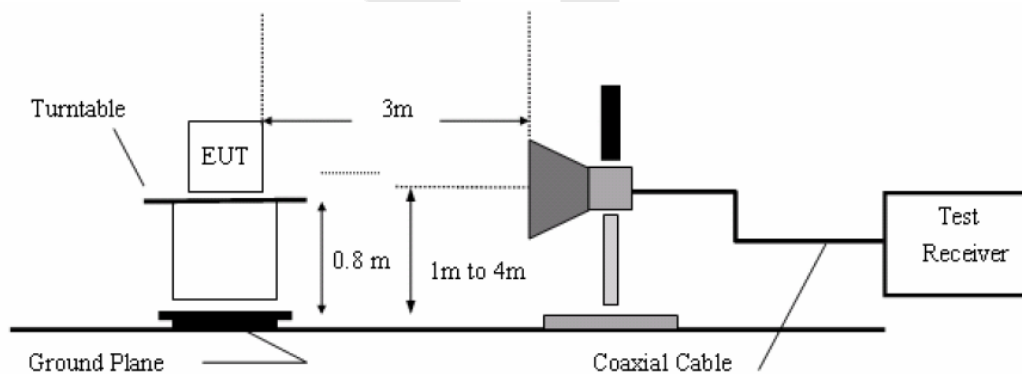

c. Test Equipment

Same as the equipment listed in 4.2.

d. Test Results

Pass.

e. Test Plots

See the following page.

Test Item	: Band edge	Test Mode	: CH Low ~ CH High
Test Voltage	: AC 120V/60Hz for Adapter	Temperature	: 24°C
Test Result	: PASS	Humidity	: 55%RH

1. Conducted Test

Frequency (MHz)	Peak Power Output(dBm)	Emission read Value(dBm)	Result of Band edge(dBc)	Band edge Limit(dBc)
<2400	3.63	-50.25	53.88	>20dBc
>2483.5	1.14	-48.06	49.20	>20dBc

2. Radiated emission Test

Frequency (MHz)	Antenna polarization (H/V)	Emission (dBuV/m)		Band edge Limit (dBuV/m)	
		PK	AV	PK	AV
<2400	V	57.34	37.37	74.00	54.00
	H	53.21	38.18	74.00	54.00
>2483.5	V	51.07	38.19	74.00	54.00
	H	53.16	36.69	74.00	54.00

Test Mode: IEEE 802.15.4

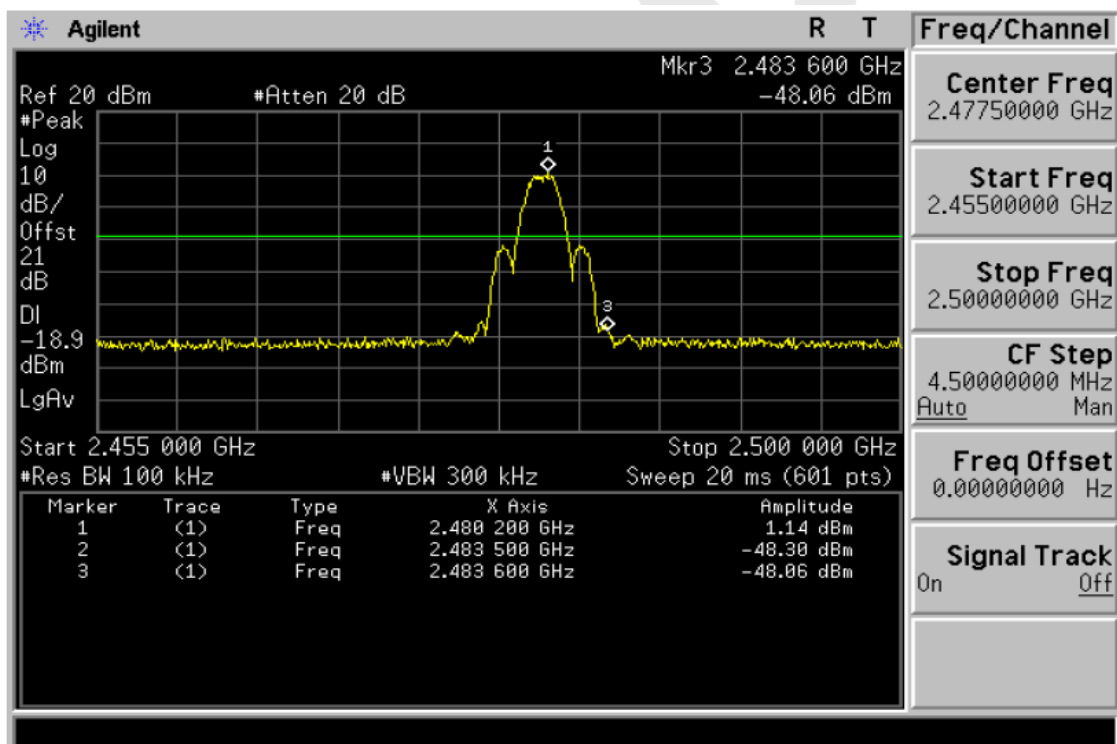
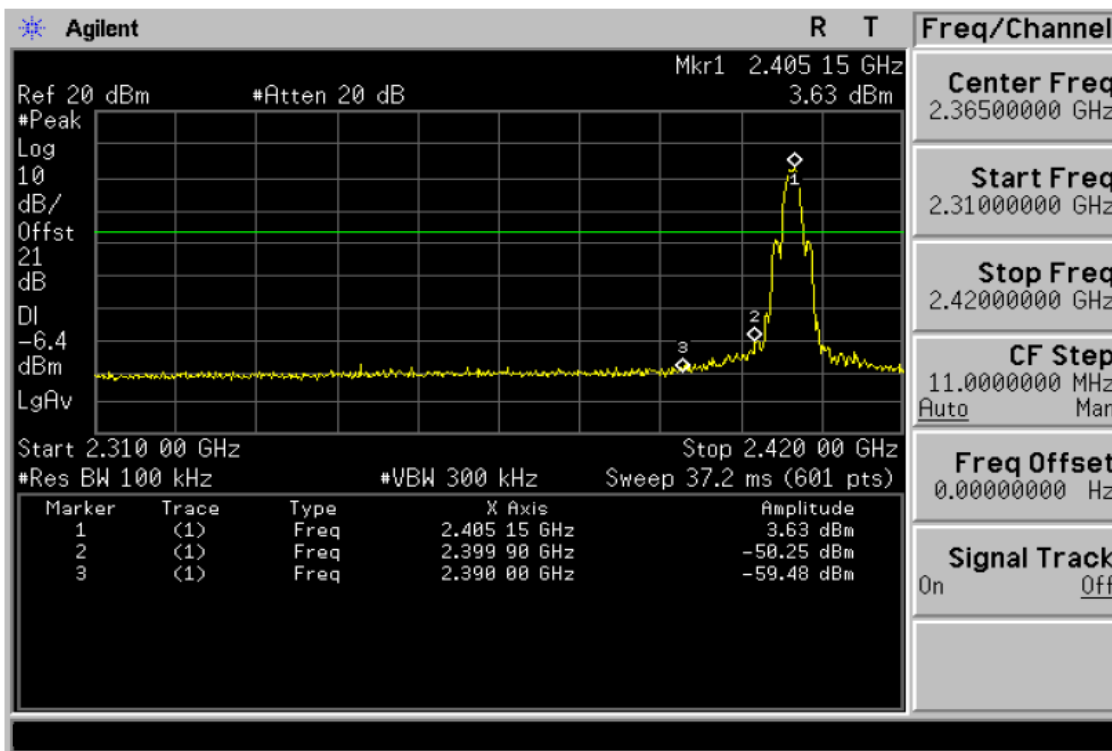

4.5. Peak Power Spectral Density

a. Limit

1. For direct sequence systems, the peak power spectral density conducted from the intentional radiator to the antenna shall not be greater than 8dBm in any 3kHz band during any time interval of continuous transmission.
2. The direct sequence operating of the hybrid system, with the frequency hopping operation turned off, shall comply with the power density requirements of paragraph (d) of this section.

b. Test Procedure

1. Place the EUT on the table and set it in transmitting mode. Remove the antenna from the EUT and then connect a low loss RF cable from the antenna port to the spectrum analyzer.
2. Set the spectrum analyzer as RBW = 3kHz, VBW = 10kHz, Span = 1.5MHz, Sweep=500s
3. Record the max. reading.
4. Repeat the above procedure until the measurements for all frequencies are completed.

c. Test Equipment

Same as the equipment listed in 4.2.

d. Test Setup

See 4.1

e. Test Results

Pass

f. Test Data

Please refer to the following data.

g. Test Plot

 See the following pages

Test mode: IEEE 802.15.4

Channel	Frequency (MHz)	PPSD (dBm/3KHz)	ΣPPSD (dBm/3KHz)	Limit (dBm)	Result
Low	2405	-8.657	-		Pass
Mid	2440	-8.221	-	8.00	Pass
High	2480	-9.081	-		Pass

2405MHz:

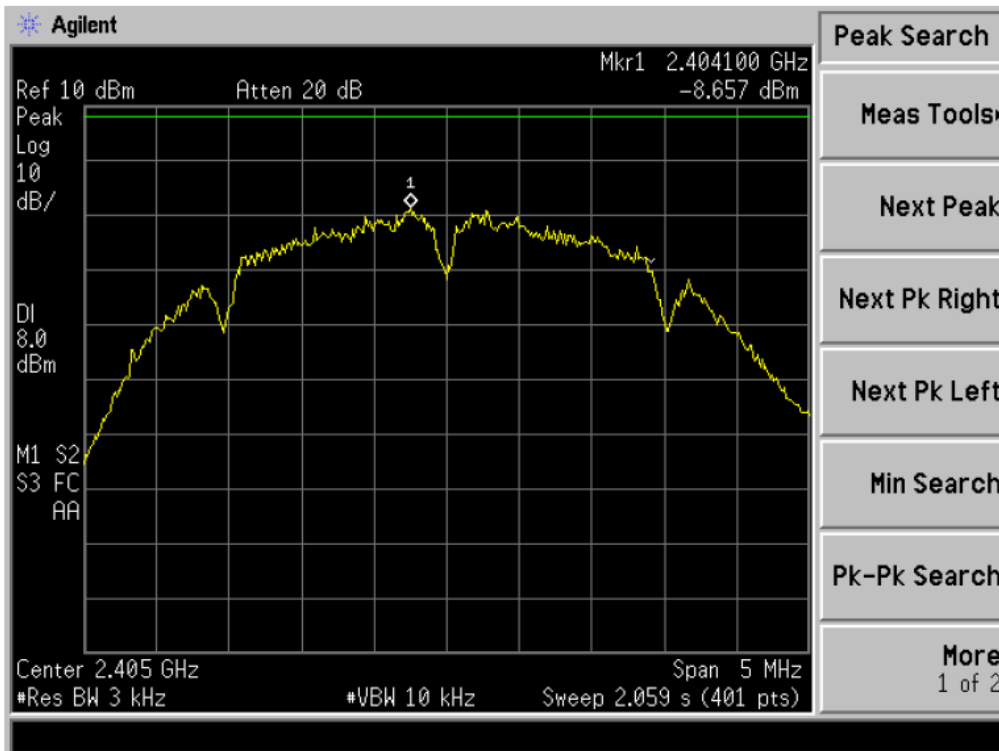

2440MHz:

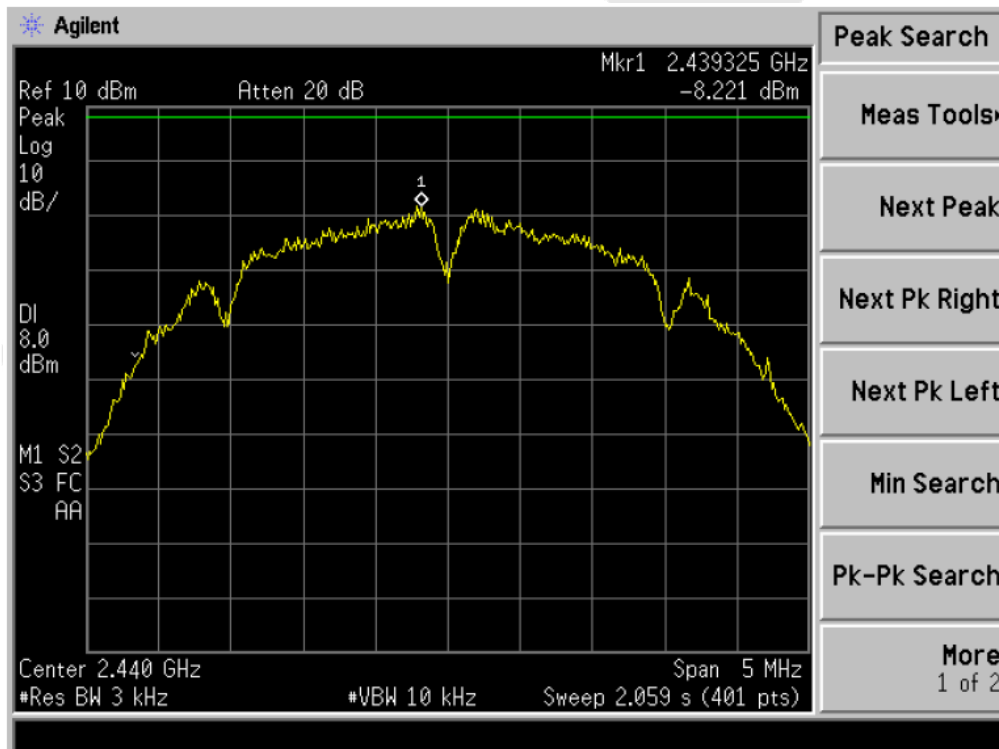

2480MHz:

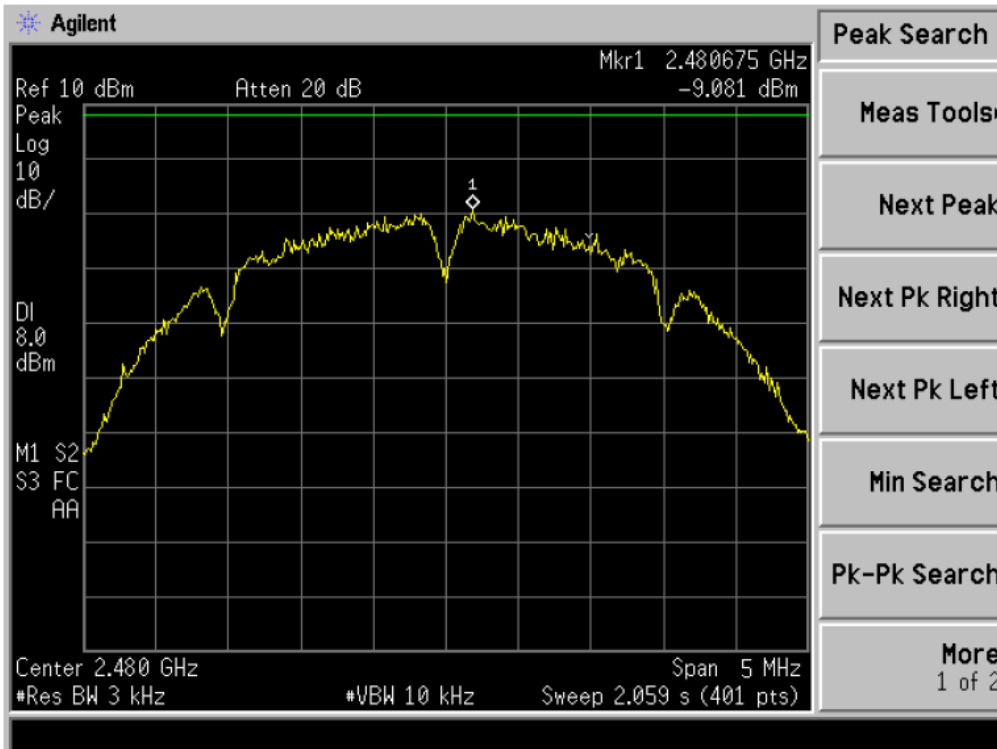

4.6. Radiated Emissions

4.6.1.1. Test Limits (< 30 MHz)

Frequency (MHz)	Field Strength (microvolts/meter)	Measurement Distance (meter)
0.009-0.490	2400/F(kHz)	300
0.490-1.705	24000/F(kHz)	30
1.705-30.0	30	30

4.6.1.2. Test Limits (\geq 30 MHz)

FIELD STRENGTH of Fundamental: @3M	FIELD STRENGTH of Harmonics	S15.209	
902-928 MHz		30 - 88 MHz	40 dBuV/m
2.4-2.4835 GHz		88 - 216 MHz	43.5
94 dB μ V/m @3m	54 dB μ V/m @3m	216 - 960 MHz	46
		ABOVE 960 MHz	54dBuV/m

In any 100 kHz bandwidth outside the frequency band in which the spread spectrum or digitally modulated intentional radiator is operating, the radio frequency power that is produced by the intentional radiator shall be at least 20 dB below that in the 100 kHz bandwidth within the band that contains the highest level of the desired power, based on either an RF conducted or a radiated measurement. Attenuation below the general limits specified in Section 15.209(a) is not required. In addition, radiated emissions which fall in the restricted bands, as defined in Section 15.205(a), must also comply with the radiated emission limits specified in Section 15.209(a) (see Section 15.205(c)).

Test Equipment

Item	Equipment	Manufacturer	Model No.	Serial No.	Last Cal.	Cal. Interval
1.	Preamplifier	Instruments corporation	EMC011830	980100	Aug. 09, 2013	1 Year
2.	EMI Test Receiver	Rohde & Schwarz	ESPI	101604	Apr. 23, 2014	1 Year
3.	Double Ridged Horn Antenna	Instruments corporation	GTH-0118	351600	Aug. 09, 2013	3 Year
4.	Bilog Broadband Antenna	Schwarzbeck	VULB9163	VULB 9163-289	Apr. 23, 2014	3 Year
5.	Pre-amplifier	SONOMA	310N	186860	Apr. 23, 2014	1 Year
6.	EMI Test Software EZ-EMC	SHURPLE	N/A	N/A	N/A	N/A

4.6.2. Test Configuration:

Block diagram of connection between the EUT and simulators



4.6.2.1. 9k to 30MHz emissions:

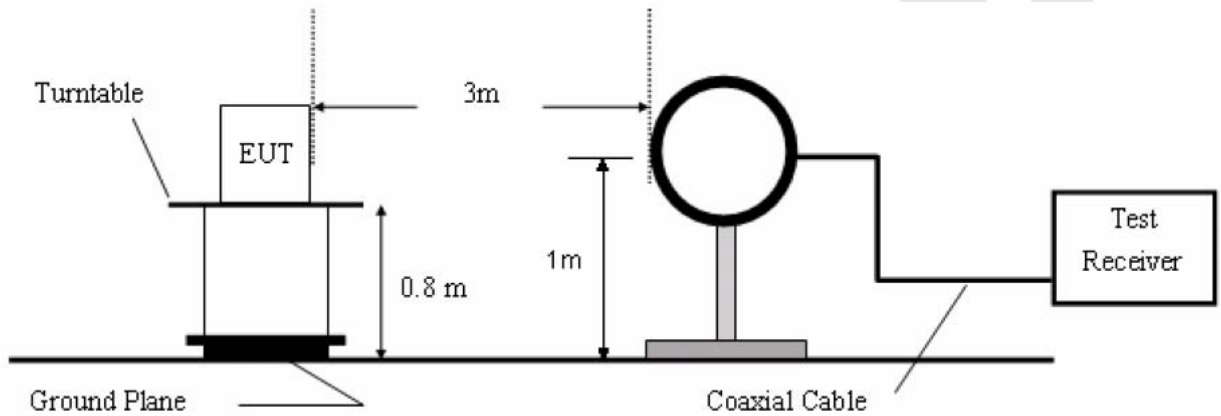

4.6.2.2. 30M to 1G emissions:

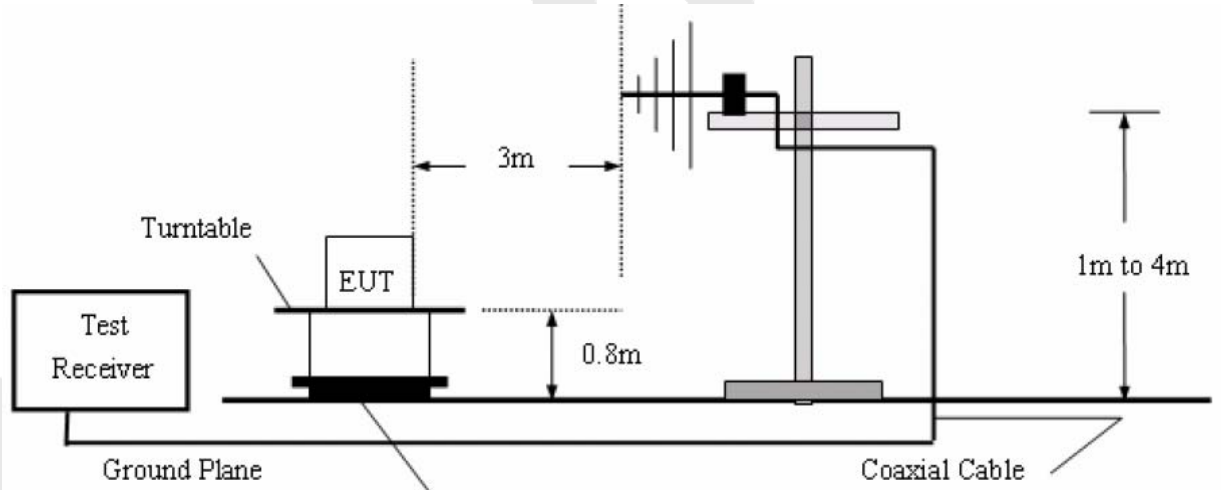

4.6.2.3. 1G to 40G emissions:

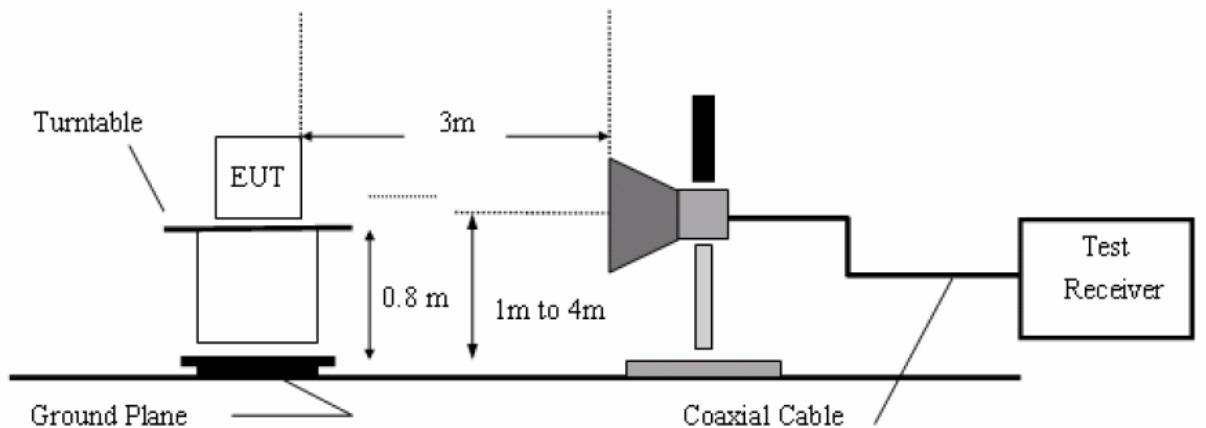

4.6.3. Test Procedure

The EUT is placed on a turn table which is 0.8 meter high above the ground. The turn table can rotate 360 degrees to determine the position of the maximum emission level. The EUT is set 3 meters away from the receiving antenna which is mounted on a antenna tower. The antenna can be moved up and down from 1 to 4 meters to find out the maximum emission level. Both horizontal and vertical polarization of the antenna are set on test.

Measurements are made on 9KHz to 30MHz and 30MHz to 26GHz range with the transmitter set to the lowest, middle, and highest channels.

All readings from 30MHz to 1GHz are quasi-peak values with a resolution bandwidth of 120kHz. All reading are above 1GHz, peak & average values with a resolution bandwidth of 1MHz.

The EUT is tested in 9*6*6 Chamber.

The test results are listed in Section 4.6.4.

4.6.4. Test Results

PASS.

Please refer to the following pages.

Job No.:	011406345E	Polarization:	Horizontal
Standard:	(RE)FCC PART15 C_3m	Power Source:	AC 120V/60Hz for Adapter
Test item:	Radiation Test	Temp.(C)/Hum.(%RH):	24.3(C)/55%RH
Test Mode:	ON	Distance:	3m

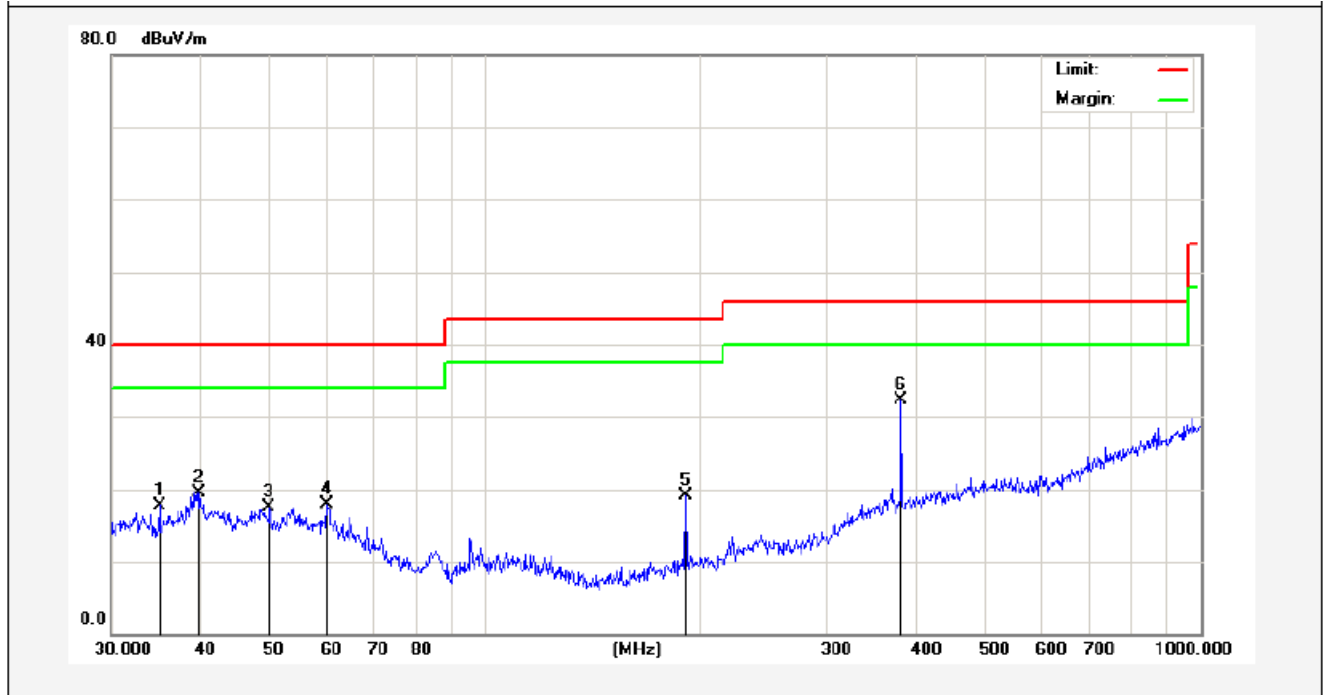

No.	Freq. (MHz)	Reading (dBuV/m)	Factor (dB/m)	Result (dBuV/m)	Limit (dBuV/)	Over Limit (dB)	Detector	Height (cm)	degree (deg)	Remark
1	35.0048	34.09	-16.29	17.80	40.00	-22.20	peak			
2	39.8542	34.02	-14.43	19.59	40.00	-20.41	peak			
3	49.8814	32.00	-14.56	17.44	40.00	-22.56	peak			
4	60.0691	33.29	-15.43	17.86	40.00	-22.14	peak			
5	190.4050	40.04	-20.92	19.12	43.50	-24.38	peak			
6	381.2487	45.53	-13.25	32.28	46.00	-13.72	peak			



Job No.:	011406345E	Polarization:	Vertical
Standard:	(RE)FCC PART15 C_3m	Power Source:	AC 120V/60Hz for Adapter
Test item:	Radiation Test	Temp.(C)/Hum.(%RH):	24.3(C)/55%RH
Test Mode:	ON	Distance:	3m

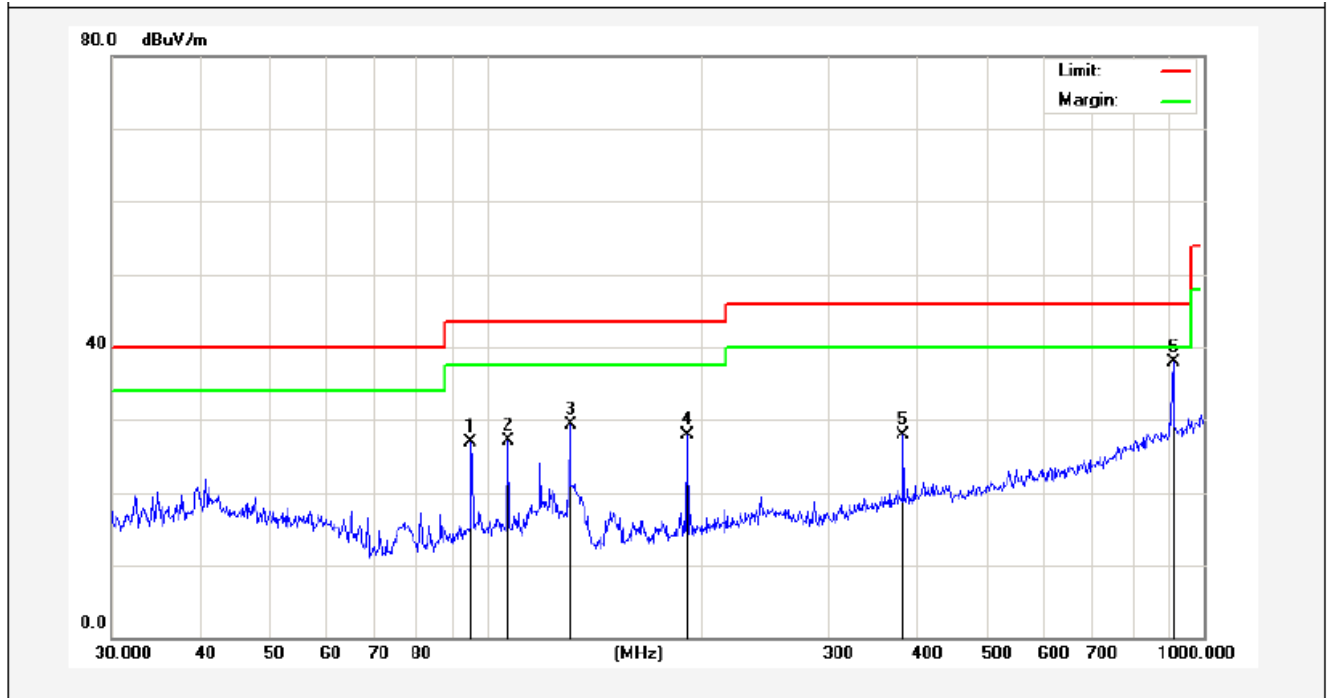

No.	Freq. (MHz)	Reading (dBuV/m)	Factor (dB/m)	Result (dBuV/m)	Limit (dBuV/)	Over Limit (dB)	Detector	Height (cm)	degree (deg)	Remark
1	95.0930	42.87	-16.00	26.87	43.50	-16.63	peak			
2	107.1337	42.73	-15.67	27.06	43.50	-16.44	peak			
3	130.8369	47.11	-17.86	29.25	43.50	-14.25	peak			
4	190.4050	43.82	-15.92	27.90	43.50	-15.60	peak			
5	381.2487	40.11	-12.25	27.86	46.00	-18.14	peak			
6	906.4823	41.52	-3.66	37.86	46.00	-8.14	peak			

Operation Mode:	IEEE 802.15.4 (CH1: 2405MHz)	Temperature :	25 °C
Frequency Range:	1-25GHz	Humidity :	50 %
Measured Distance:	3m	Test Result:	PASS

Freq. (MHz)	Ant. Pol. H/V	Emission Level(dBuV/m)		Limit 3m(dBuV/m)		Margin(dB)	
		PK	AV	PK	AV	PK	AV
4810	V	56.42	46.12	74	54	-17.58	-7.88
7215	V	59.24	47.33	74	54	-14.76	-6.67
9620	V	58.35	46.47	74	54	-15.65	-7.53
12025	V	60.12	47.05	74	54	-13.88	-6.95
14430	V	57.40	46.02	74	54	-16.6	-7.98
4810	H	58.33	46.89	74	54	-15.67	-7.11
7215	H	58.36	46.61	74	54	-15.64	-7.39
9620	H	59.76	47.44	74	54	-14.24	-6.56
12025	H	58.24	47.12	74	54	-15.76	-6.88
14430	H	56.05	45.06	74	54	-17.95	-8.94

Other harmonics emissions are lower than 20dB below the allowable limit.

- Note:**
- (1) All Readings are Peak Value and AV.
 - (2) Emission Level= Reading Level+ Probe Factor +Cable Loss.
 - (3) The average measurement was not performed when the peak measured data under the limit of average detection.

Operation Mode:	IEEE 802.15.4 (CH8: 2440MHz)	Temperature :	25 °C
Frequency Range:	1-25GHz	Humidity :	50 %
Measured Distance:	3m	Test Result:	PASS

Freq. (MHz)	Ant. Pol. H/V	Emission Level(dBuV/m)		Limit 3m(dBuV/m)		Margin(dB)	
		PK	AV	PK	AV	PK	AV
4880	V	57.19	46.87	74	54	-16.81	-7.13
7320	V	53.22	47.62	74	54	-20.78	-6.38
9760	V	56.81	46.35	74	54	-17.19	-7.65
12200	V	60.01	47.05	74	54	-13.99	-6.95
14640	V	56.44	46.04	74	54	-17.56	-7.96
4880	H	57.31	46.79	74	54	-16.69	-7.21
7320	H	58.21	46.11	74	54	-15.79	-7.89
9760	H	55.94	47.44	74	54	-18.06	-6.56
12200	H	58.24	47.22	74	54	-15.76	-6.78
14640	H	56.33	46.04	74	54	-17.67	-7.96

Other harmonics emissions are lower than 20dB below the allowable limit.

- Note:**
- (1) All Readings are Peak Value and AV.
 - (2) Emission Level= Reading Level+ Probe Factor +Cable Loss.
 - (3) The average measurement was not performed when the peak measured data under the limit of average detection.

Operation Mode:	IEEE 802.15.4 (CH16: 2480MHz)	Temperature :	25 °C
Frequency Range:	1-25GHz	Humidity :	50 %
Measured Distance:	3m	Test Result:	PASS

Freq. (MHz)	Ant. Pol. H/V	Emission Level(dBuV/m)		Limit 3m(dBuV/m)		Margin(dB)	
		PK	AV	PK	AV	PK	AV
4960	V	62.11	46.25	74	54	-11.89	-7.75
7440	V	59.24	44.03	74	54	-14.76	-9.97
9920	V	59.21	44.21	74	54	-14.79	-9.79
12400	V	60.35	45.39	74	54	-13.65	-8.61
14880	V	58.40	44.17	74	54	-15.60	-9.83
4960	H	58.79	45.41	74	54	-15.21	-8.59
7440	H	58.36	45.03	74	54	-15.64	-8.97
9920	H	59.02	45.91	74	54	-14.98	-8.09
12400	H	58.48	42.75	74	54	-15.52	-11.25
14880	H	56.11	42.36	74	54	-17.89	-11.64

Other harmonics emissions are lower than 20dB below the allowable limit.

- Note:**
- (1) All Readings are Peak Value and AV.
 - (2) Emission Level= Reading Level+ Probe Factor +Cable Loss.
 - (3) The average measurement was not performed when the peak measured data under the limit of average detection.

5. PHOTOGRAPH

5.1. Photo of Conducted Emission Measurement



5.2. Photo of Radiation Emission Test

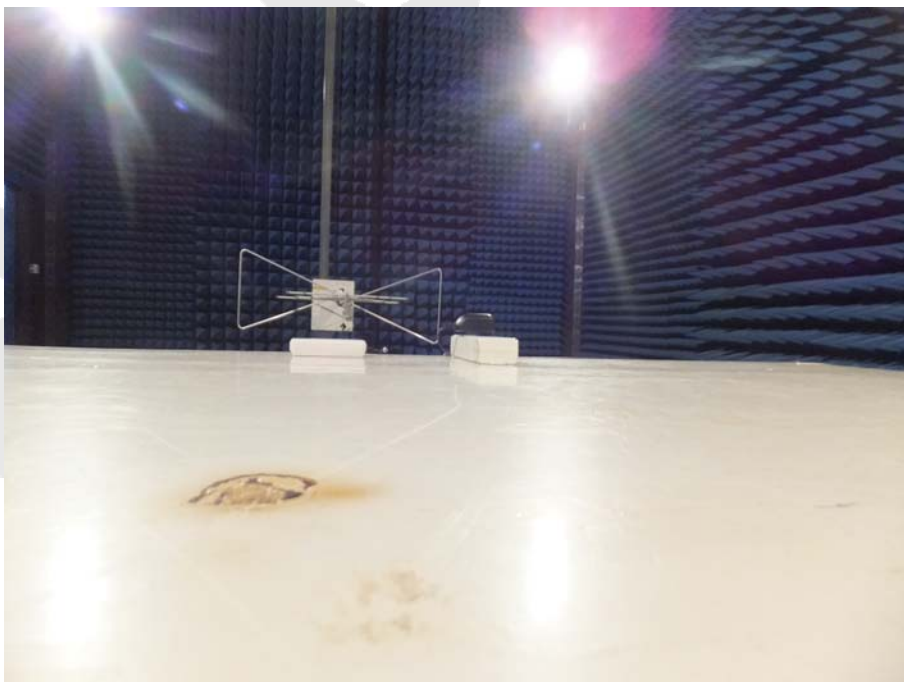

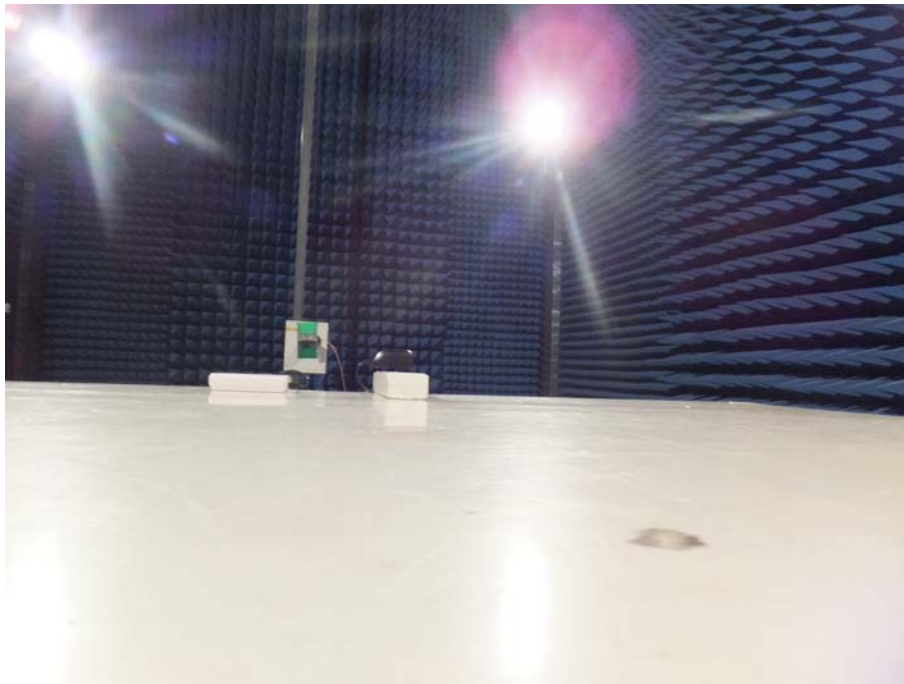

APPENDIX I (EXTERNAL PHOTOS)

Figure 1
The EUT-Overall View



The EUT is placed in the host.

Figure 2
The EUT-Front View

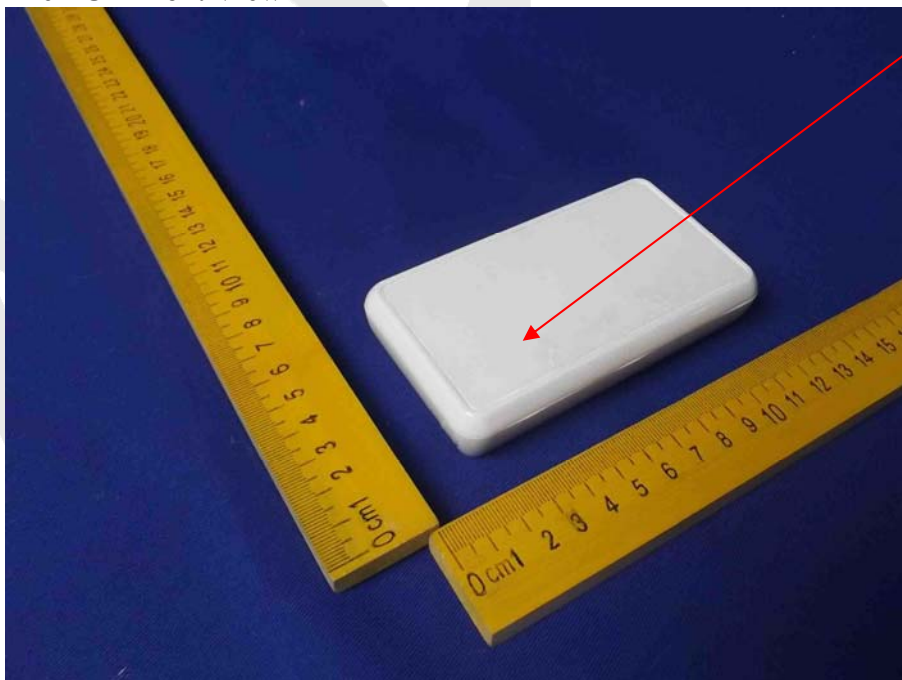

The EUT is placed in the host.

Figure 3
The EUT- Back View

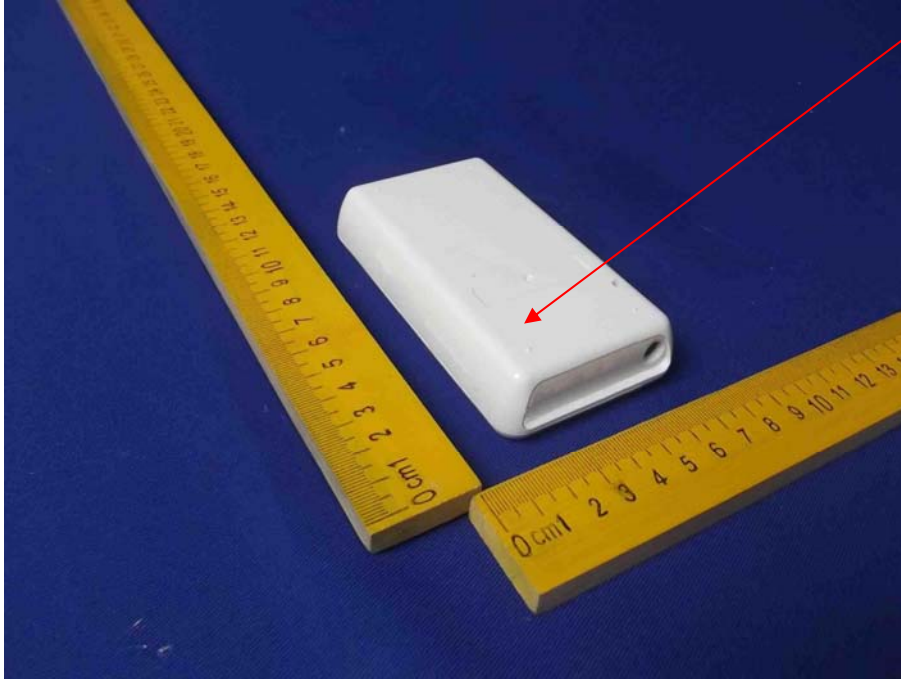

The EUT is placed in the host.

Anbotek

APPENDIX II (INTERNAL PHOTOS)

Figure 4
The EUT-Inside View



Figure 5
The PCB-Front View (on the Evaluation Kit)

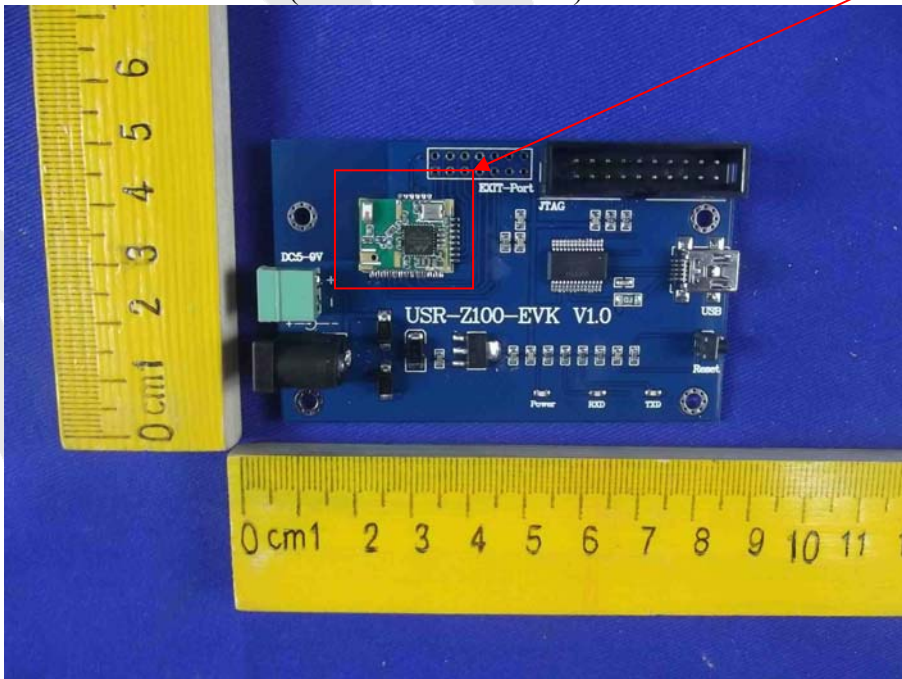

The module is placed on the Evaluation Kit.

Figure 6
The PCB-Back View (on the Evaluation Kit)

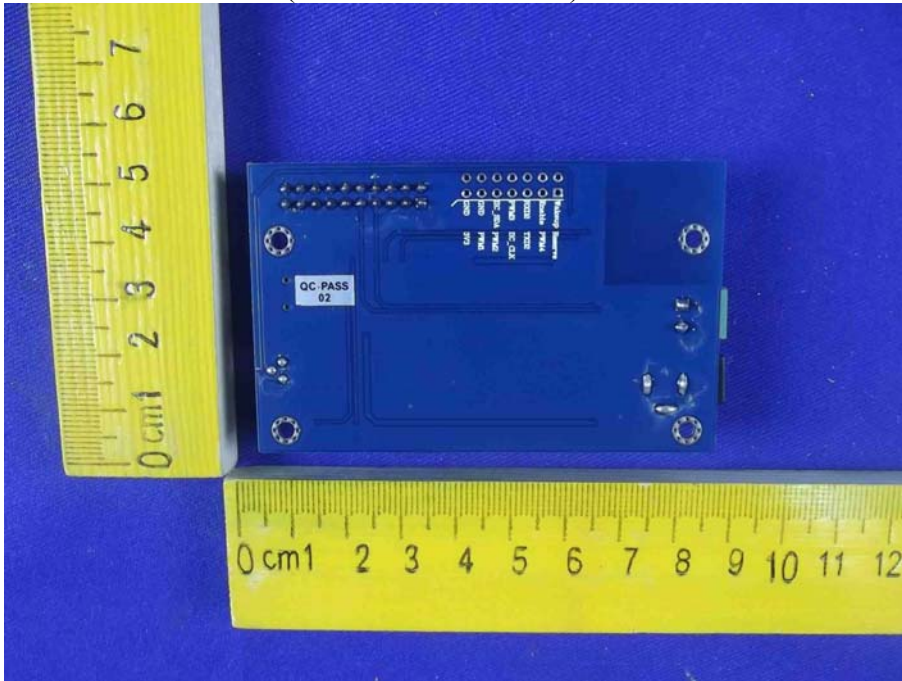

Figure 7
The EUT-Front View

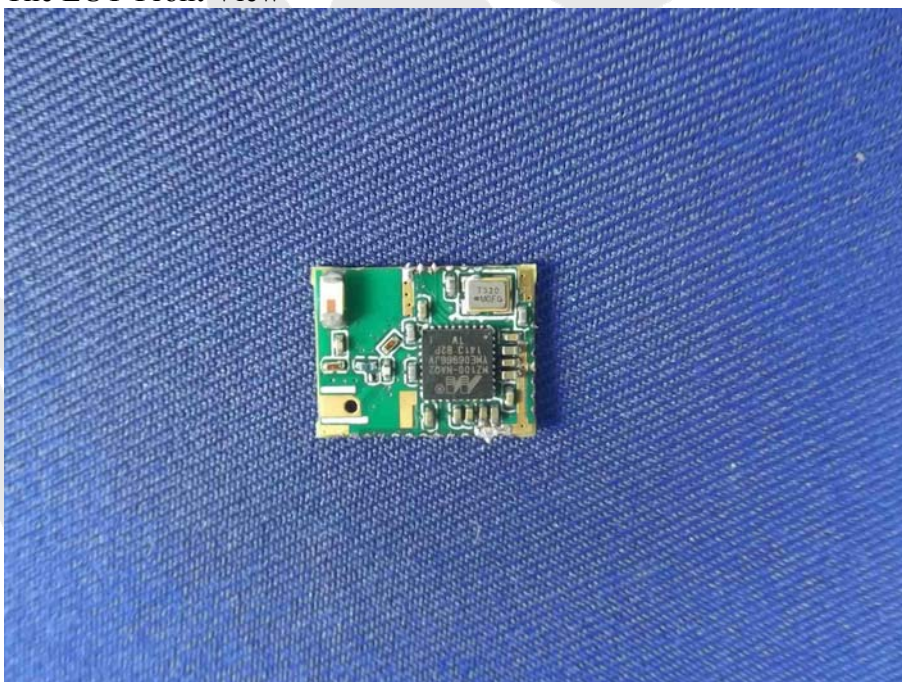
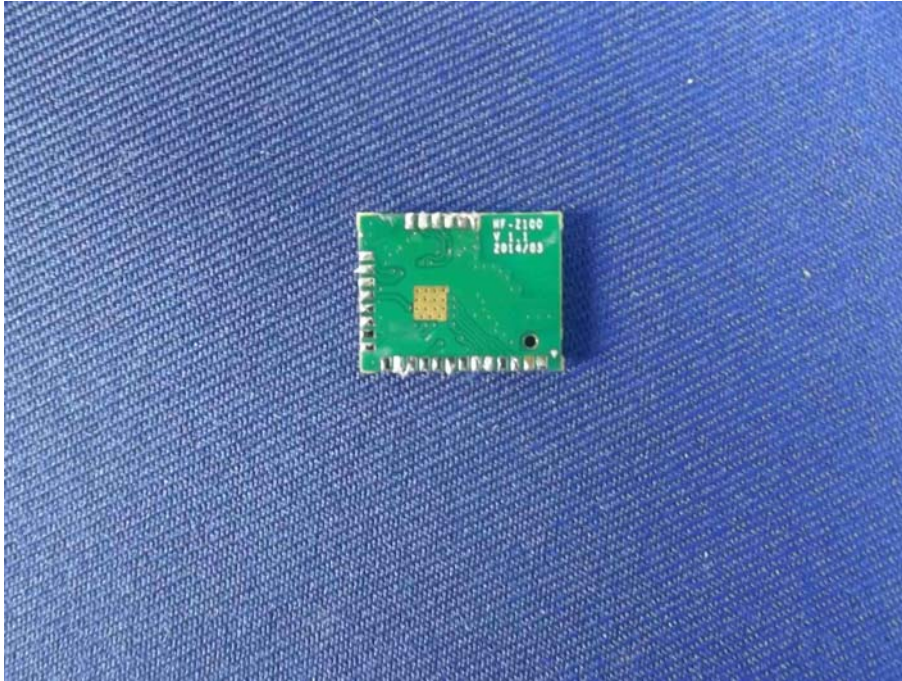

Figure 8
The EUT-Back View



Anbotek