



Shenzhen CTL Testing Technology Co., Ltd.
Tel: +86-755-89486194 Fax: +86-755-89486194-805

FCC PART 15 SUBPART C TEST REPORT

Part 15.247

Report Reference No......: **CTL1406231413-WF**

Compiled by

(position+printed name+signature) .: File administrators Jacky Chen

Jacky Chen

Name of the organization performing the tests

Test Engineer Tracy Qi

Tracy Qi

(position+printed name+signature) .:

Approved by

(position+printed name+signature) .: Manager Tracy Qi

Tracy Qi

Date of issue.....: July 22, 2014

Test Laboratory Name: **Shenzhen CTL Testing Technology Co., Ltd.**

Address: Floor 1-A, Baisha Technology Park, No.3011, Shahexi Road, Nanshan District, Shenzhen, China 518055

Applicant's name.....: **Shenzhen Yingdakang Technology Co., LTD**

Address: Room 8004, B/51, 2nd Dist., Shangtang Songzi Park, Minzhi, Longhua, Shenzhen, China

Test specification:

Standard: FCC Part 15.247: Operation within the bands 902–928 MHz, 2400–2483.5 MHz, and 5725–5850 MHz.

TRF Originator.....: Shenzhen CTL Testing Technology Co., Ltd.

Master TRF.....: Dated 2011-01

Shenzhen CTL Testing Technology Co., Ltd. All rights reserved.

This publication may be reproduced in whole or in part for non-commercial purposes as long as the Shenzhen CTL Testing Technology Co., Ltd. is acknowledged as copyright owner and source of the material. Shenzhen CTL Testing Technology Co., Ltd. takes no responsibility for and will not assume liability for damages resulting from the reader's interpretation of the reproduced material due to its placement and context.

Test item description: 802.11b/g/n wireless router

FCC ID.....: 2ACSIDWA-N223SERIES

Trade Mark: N/A

Model/Type reference: DWA-N223SERIES, DWA-N115SERIES

Modulation: 802.11b DSSS, 802.11g/n: OFDM

Work Frequency Range: 802.11b/g/n(20MHz): 2412~2462MHz

802.11n(40MHz): 2422~2452

Antenna Type: Undetachable

Antenna Gain.....: 2dBi

Result: **Positive**

TEST REPORT

Test Report No. :	CTL1406231413-WF	July 22, 2014
		Date of issue

Equipment under Test : 802.11b/g/n wireless router

Model /Type : DWA-N223SERIES

Listed Modes : DWA-N115SERIES

Difference Description : The models have same electrical, PCB and BOM, only the model's name and color are different for marketing requirements.

Applicant : **Shenzhen Yingdakang Technology Co., LTD**

Address : Room 8004, B/51, 2nd Dist., Shangtang Songzi Park, Minzhi, Longhua, Shenzhen, China

Manufacturer : **Shenzhen Yingdakang Technology Co., LTD**

Address : Room 8004, B/51, 2nd Dist., Shangtang Songzi Park, Minzhi, Longhua, Shenzhen, China

Test Result according to the standards on page 4:

Positive

The test report merely corresponds to the test sample.
It is not permitted to copy extracts of these test result without the written permission of the test laboratory.

Contents

1.	<u>TEST STANDARDS.....</u>	4
2.	<u>SUMMARY</u>	5
2.1.	General Remarks	5
2.2.	Equipment Under Test	5
2.3.	Short description of the Equipment under Test (EUT)	5
2.4.	EUT operation mode	5
2.5.	EUT configuration	6
2.6.	NOTE	6
2.7.	Related Submittal(s) / Grant (s)	6
2.8.	Modifications	6
3.	<u>TEST ENVIRONMENT</u>	7
3.1.	Address of the test laboratory	7
3.2.	Test Facility	7
3.3.	Environmental conditions	7
3.4.	Configuration of Tested System	7
3.5.	Duty Cycle	8
3.6.	Statement of the measurement uncertainty	8
3.7.	Equipments Used during the Test	9
3.8.	Summary of Test Result	10
4.	<u>TEST CONDITIONS AND RESULTS.....</u>	11
4.1.	Conducted Emissions Test	11
4.2.	Radiated Emission Test	14
4.3.	6dB Bandwidth Measurement	31
4.4.	Maximum Peak Output Power	44
4.5.	Band Edge Measurement	45
4.6.	Power Spectral Density Measurement	78
4.7.	Spurious RF Conducted Emission	91
4.8.	Antenna Requirement	116
5.	<u>TEST SETUP PHOTOS OF THE EUT</u>	117
6.	<u>EXTERNAL AND INTERNAL PHOTOS OF THE EUT</u>	119

1. TEST STANDARDS

The tests were performed according to following standards:

[FCC Part 15.247](#): Frequency Hopping, Direct Spread Spectrum and Hybrid Systems that are in operation within the bands of 902-928 MHz, 2400-2483.5 MHz, and 5725-5850 MHz.

[ANSI C63.10-2009](#): American National Standard for Testing Unlicensed Wireless Devices.

[ANSI C63.4-2009](#)

[KDB Publication No. 558074 D01 v03r02 Guidance on Measurements for Digital Transmission Systems](#)



2. SUMMARY

2.1. General Remarks

Date of receipt of test sample	:	July 06, 2014
Testing commenced on	:	July 06, 2014
Testing concluded on	:	July 22, 2014

2.2. Equipment Under Test

Power supply system utilised

Power supply voltage	:	<input checked="" type="radio"/> 120V / 60 Hz	<input type="radio"/> 115V / 60Hz
		<input type="radio"/> 12 V DC	<input type="radio"/> 24 V DC
		<input type="radio"/> Other (specified in blank below)	

Description of the test mode

IEEE 802.11b/g/n: Thirteen channels are provided to the EUT, but only eleventh channels used for USA and Canada.

Channel	Frequency(MHz)	Channel	Frequency(MHz)
1	2412	8	2447
2	2417	9	2452
3	2422	10	2457
4	2427	11	2462
5	2432		
6	2437		
7	2442		

For 20MHz bandwidth systems, use channel 1~11.

For 40MHz bandwidth systems, use channel 3~9.

2.3. Short description of the Equipment under Test (EUT)

802.11b/g/n wireless router, support 802.11b/g/n.

For more details, refer to the user's manual of the EUT.

Serial number: Prototype

2.4. EUT operation mode

Test Mode:

1. The EUT has been tested under normal operating condition.
2. Test program used to control the EUT for staying in continuous transmitting and receiving mode is programmed. Channel low (2412MHz), mid (2442MHz) and high (2462MHz) with highest data rate are chosen for full testing.

3. Test Mode:

Test Mode(TM)	Description	Remark
1	Transmitting	802.11 b 2412MHz, 2437MHz, 2462MHz
2	Transmitting	802.11 g 2412MHz, 2437MHz, 2462MHz
3	Transmitting	802.11 n HT20 2412MHz, 2437MHz, 2462MHz
4	Transmitting	802.11 n HT40 2422MHz, 2437MHz, 2452MHz

2.5. EUT configuration

The following peripheral devices and interface cables were connected during the measurement:

- - supplied by the manufacturer
- - supplied by the lab

- Notebook PC

Manufacturer : DELL

Model No. : PP18L

2.6. NOTE

1. The EUT is an 802.11b/g/n wifi router, The functions of the EUT listed as below:

	Test Standards	Reference Report
WLAN 802.11b/g, 802.11n	FCC Part 15 Subpart C (Section15.247)	CTL1406231413-WF
	FCC Per 47 CFR 2.1091(b)	CTL1406231413-WM

2. The frequency bands used in this EUT are listed as follows:

Frequency Band(MHz)	2400-2483.5	5150-5350	5470-5725	5725-5850
802.11b	√	—	—	—
802.11g	√	—	—	—
802.11n(20MHz)	√	—	—	—
802.11n(40MHz)	√	—	—	—

3. The EUT incorporates a MIMO function, Physically, the EUT provides two completed transmitter and two completed receivers.

Modulation Mode	TX Function
802.11b	1TX
802.11g	1TX
802.11n (20MHz)	2TX
802.11n (40MHz)	2TX

2.7. Related Submittal(s) / Grant (s)

This submittal(s) (test report) is intended for FCCID: 2ACSIDWA-N223SERIES filing to comply with of the FCC part15.247 Rules.

2.8. Modifications

No modifications were implemented to meet testing criteria.

3. TEST ENVIRONMENT

3.1. Address of the test laboratory

Shenzhen CTL Testing Technology Co., Ltd.
 Floor 1-A, Baisha Technology Park, No.3011, Shahexi Road, Nanshan District, Shenzhen, China 518055

The sites are constructed in conformance with the requirements of ANSI C6230, ANSI C63.4 (2009) and CISPR Publication 22.

3.2. Test Facility

The test facility is recognized, certified, or accredited by the following organizations:

IC Registration No.: 9618B

The 3m alternate test site of Shenzhen CTL Testing Technology Co., Ltd. EMC Laboratory has been registered by Certification and Engineer Bureau of Industry Canada for the performance of with Registration No.: 9618B on November 13, 2013.

FCC-Registration No.: 970318

Shenzhen CTL Testing Technology Co., Ltd. EMC Laboratory has been registered and fully described in a report filed with the (FCC) Federal Communications Commission. The acceptance letter from the FCC is maintained in our files. Registration 970318, December 19, 2013.

3.3. Environmental conditions

During the measurement the environmental conditions were within the listed ranges:

Temperature:	<u>15-35 ° C</u>
Humidity:	<u>30-60 %</u>
Atmospheric pressure:	<u>950-1050mbar</u>

3.4. Configuration of Tested System

AC power line conduction emission tes configuration

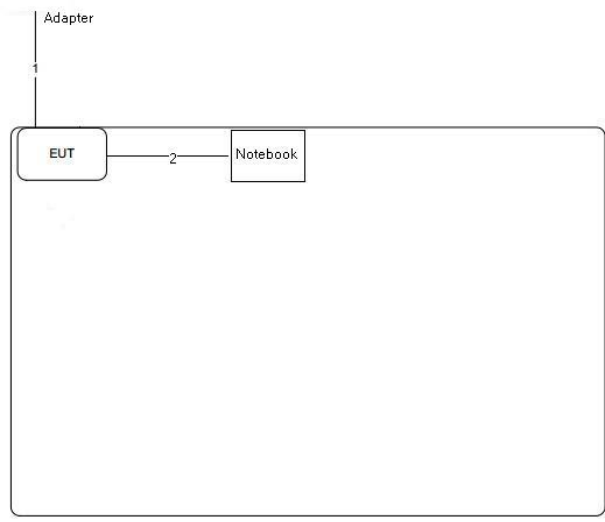

Item	Connection	Shield	Length
1	DC Power Cable	No	1.8m
2	RJ-45 Cable	No	1m

Radiation emission tes configuration

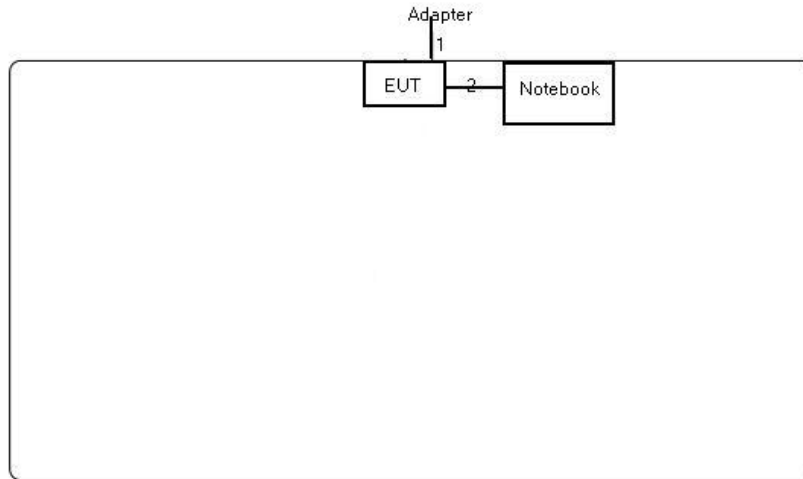

Item	Connection	Shield	Length
1	DC Power Cable	No	1.8m
2	RJ-45 Cable	No	1m

3.5. Duty Cycle

Operated Mode for Worst Duty Cycle		
<input type="checkbox"/>	Operated normally mode for worst duty cycle	
<input checked="" type="checkbox"/>	Operated test mode for worst duty cycle	
Mode	Duty Cycle (%)	Duty Factor (dB)
11b	100	0
11g	100	0
11n HT20	100	0
11n HT40	100	0

3.6. Statement of the measurement uncertainty

The data and results referenced in this document are true and accurate. The reader is cautioned that there may be errors within the calibration limits of the equipment and facilities. The measurement uncertainty was calculated for all measurements listed in this test report acc. to CISPR 16 - 4 „Specification for radio disturbance and immunity measuring apparatus and methods – Part 4: Uncertainty in EMC Measurements“ and is documented in the Shenzhen CTL Testing Technology Co., Ltd. quality system acc. to DIN EN ISO/IEC 17025. Furthermore, component and process variability of devices similar to that tested may result in additional deviation. The manufacturer has the sole responsibility of continued compliance of the device.

Hereafter the best measurement capability for CTL laboratory is reported:

Test	Range	Measurement Uncertainty	Notes
Radiated Emission	30~1000MHz	4.10dB	(1)
Radiated Emission	1~26.5GHz	4.32dB	(1)
Conducted Disturbance	0.15~30MHz	3.20dB	(1)

(1) This uncertainty represents an expanded uncertainty expressed at approximately the 95% confidence level using a coverage factor of k=2.

3.7. Equipments Used during the Test

Test Equipment	Manufacturer	Model No.	Serial No.	Calibration Date	Calibration Due Date
Bilog Antenna	Sunol Sciences Corp.	JB1	A061713	2013/07/12	2014/07/11
EMI Test Receiver	R&S	ESCI	103710	2013/07/10	2014/07/09
Spectrum Analyzer	Agilent	E4407B	MY45108355	2014/07/05	2015/07/04
Controller	EM Electronics	Controller EM 1000	N/A	2014/07/05	2015/07/04
Horn Antenna	Sunol Sciences Corp.	DRH-118	A062013	2014/07/11	2015/07/10
Horn Antenna	SCHWARZBECK	BBHA9170	1562	2014/07/11	2015/07/10
Active Loop Antenna	SCHWARZBECK	FMZB1519	1519-037	2013/07/12	2014/07/11
LISN	R&S	ENV216	101316	2013/07/10	2014/07/09
LISN	SCHWARZBECK	NSLK8127	8127687	2013/07/10	2014/07/09
Microwave Preamplifier	HP	8349B	3155A00882	2014/07/09	2015/07/08
Amplifier	HP	8447D	3113A07663	2013/07/10	2014/07/11
Transient Limiter	Com-Power	LIT-153	532226	2013/07/10	2014/07/09
Radio Communication Tester	R&S	CMU200	3655A03522	2013/07/06	2014/07/05
Temperature/Humidity Meter	zhicheng	ZC1-2	22522	2013/07/10	2014/07/09
SIGNAL GENERATOR	HP	8647A	3200A00852	2013/07/10	2014/07/09
Wideband Peak Power Meter	Anritsu	ML2495A	220.23.35	2013/07/06	2014/07/05
Climate Chamber	ESPEC	EL-10KA	A20120523	2013/07/06	2014/07/05
High-Pass Filter	K&L	9SH10-2700/X12750-O/O	/	2013/07/06	2014/07/05
High-Pass Filter	K&L	41H10-1375/U12750-O/O	/	2013/07/06	2014/07/05
RF Cable	HUBER+SUHNER	RG214	/	2014/07/09	2015/07/08

3.8. Summary of Test Result

FCC PART 15		
FCC Part 15.207	AC Power Conducted Emission	PASS
FCC Part 15.247(a)(2)	6dB Bandwidth	PASS
FCC Part 15.247(d)	Spurious RF Conducted Emission	PASS
FCC Part 15.247(b)	Maximum Peak Output Power	PASS
FCC Part 15.247(e)	Power Spectral Density	PASS
FCC Part 15.109/ 15.205/ 15.209	Radiated Emissions	PASS
FCC Part 15.247(d)	Band Edge Compliance of RF Emission	PASS
FCC Part 15.203/15.247 (b)	Antenna Requirement	PASS

Remark: The measurement uncertainty is not included in the test result.

Preliminary tests were performed in different data rate to find the worst radiated emission. The data rate shown in the table below is the worst-case rate with respect to the specific test item. Investigation has been done on all the possible configurations for searching the worst cases. The following table is a list of the test modes shown in this test report.

Test Items	Mode	Data Rate	Channel
AC Power Conducted Emission	Normal Link	11 Mbps	1
Maximum Peak Conducted Output Power Power Spectral Density 6dB Bandwidth Spurious RF conducted emission	11b/DSSS	11 Mbps	1/6/11
	11g/OFDM	54 Mbps	1/6/11
	11n(20MHz)/OFDM	65Mbps	1/6/11
	11n(40MHz)/OFDM	150Mbps	3/6/9
Radiated Emission 30MHz~1GHz	11b/DSSS	11 Mbps	1/6/11
	11g/OFDM	54 Mbps	1/6/11
	11n(20MHz)/OFDM	65Mbps	1/6/11
	11n(40MHz)/OFDM	150Mbps	3/6/9
Radiated Emission 1GHz~10th Harmonic	11b/DSSS	11 Mbps	1/6/11
	11g/OFDM	54 Mbps	1/6/11
	11n(20MHz)/OFDM	65Mbps	1/6/11
	11n(40MHz)/OFDM	150Mbps	3/6/9
Band Edge Compliance of RF Emission	11b/DSSS	11 Mbps	1/11
	11g/OFDM	54 Mbps	1/11
	11n(20MHz)/OFDM	65Mbps	1/11
	11n(40MHz)/OFDM	150Mbps	3/9

Note1: According exploratory test, EUT will have maximum output power in those data rate, so those data rate were used for all test.

Note2: This device use MIMO 2X2 antennas, for 802.11b/g mode, based exploratory test, when transmit with Antenna 1 have worse emissions, so the final radiated spurious emissions were tested with Antenna 1. For 802.11n mode, all the radiated spurious emissions and band edge test were performed with two antennas transmit synchronous.

4. TEST CONDITIONS AND RESULTS

4.1. Conducted Emissions Test

TEST CONFIGURATION

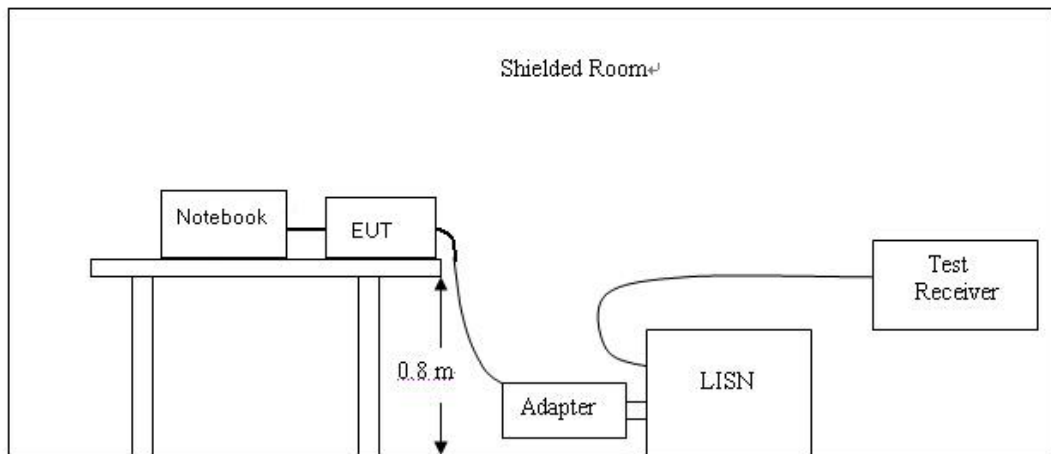

TEST PROCEDURE

For unintentional device, according to § 15.107(a) Line Conducted Emission Limits is as following:

Frequency (MHz)	Maximum RF Line Voltage (dB μ v)			
	CLASS A		CLASS B	
	Q.P.	Ave.	Q.P.	Ave.
0.15 - 0.50	79	66	66-56*	56-46*
0.50 - 5.00	73	60	56	46
5.00 - 30.0	73	60	60	50

* Decreasing linearly with the logarithm of the frequency

For intentional device, according to §15.207(a) Line Conducted Emission Limit is same as above table.

1. Please follow the guidelines in ANSI C63.4-2009.
2. The EUT was placed 0.4 meter from the conducting wall of the shielding room was kept at least 80 centimeters from any other grounded conducting surface.
3. Connect EUT to the power mains through a line impedance stabilization network (LISN).
4. All the support units are connecting to the other LISN.
5. The LISN provides 50 ohm coupling impedance for the measuring instrument.
6. The FCC states that a 50 ohm, 50 microhenry LISN should be used.
7. Both sides of AC line were checked for maximum conducted interference.
8. The frequency range from 150 kHz to 30 MHz was searched.
9. Set the test-receiver system to Peak Detect Function and specified bandwidth with Maximum Hold Mode.

The RBW/VBW for 150KHz to 30MHz: 9KHz

TEST RESULTS

SCAN TABLE: "Voltage (9K-30M)FIN"
 Short Description: 150K-30M Voltage

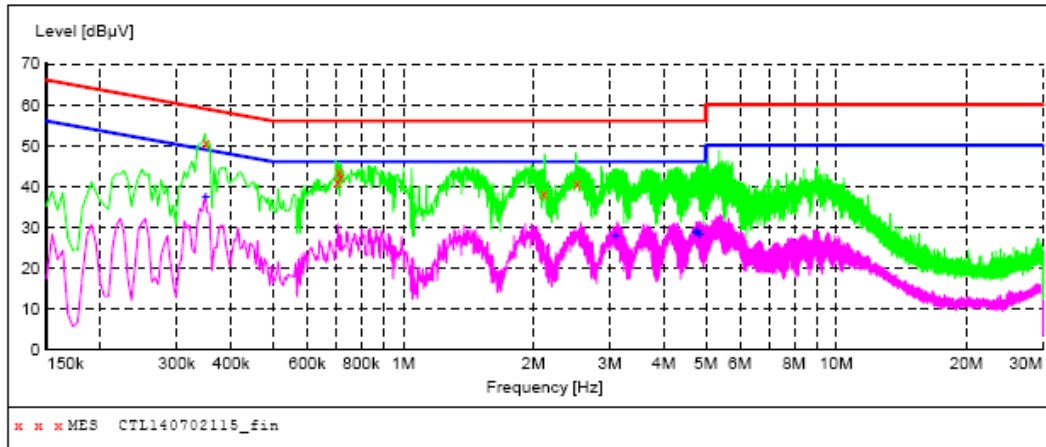

MEASUREMENT RESULT: "CTL140702115_fin"

7/2/2014 11:51AM

Frequency MHz	Level dBµV	Transd dB	Limit dBµV	Margin dB	Detector	Line	PE
0.350000	50.50	10.2	59	8.5	QP	L1	GND
0.704000	41.30	10.2	56	14.7	QP	L1	GND
0.710000	43.40	10.2	56	12.6	QP	L1	GND
0.716000	42.30	10.2	56	13.7	QP	L1	GND
2.114000	38.10	10.4	56	17.9	QP	L1	GND
2.516000	40.60	10.4	56	15.4	QP	L1	GND

MEASUREMENT RESULT: "CTL140702115_fin2"

7/2/2014 11:51AM

Frequency MHz	Level dBµV	Transd dB	Limit dBµV	Margin dB	Detector	Line	PE
0.350000	37.50	10.2	49	11.5	AV	L1	GND
3.092000	27.90	10.4	46	18.1	AV	L1	GND
4.742000	28.80	10.4	46	17.2	AV	L1	GND
4.784000	28.90	10.4	46	17.1	AV	L1	GND
4.826000	28.30	10.4	46	17.7	AV	L1	GND
4.844000	28.20	10.4	46	17.8	AV	L1	GND



SCAN TABLE: "Voltage (9K-30M)FIN"
 Short Description: 150K-30M Voltage

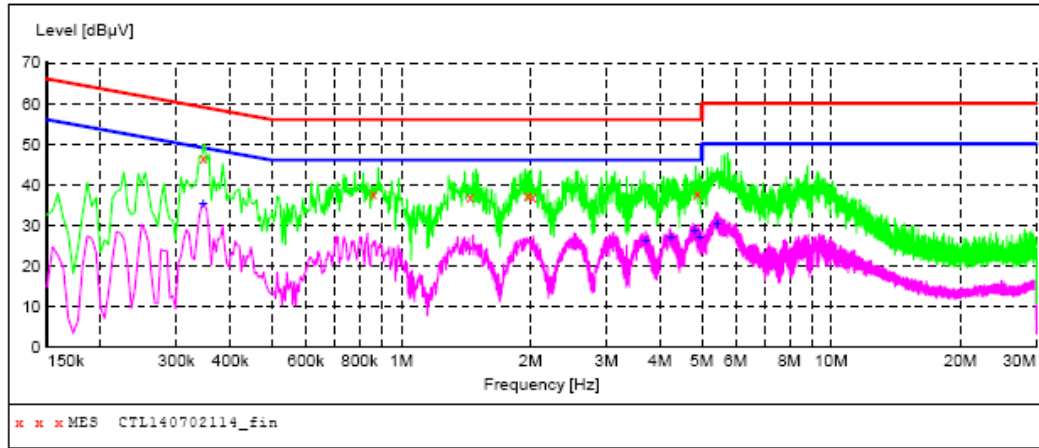

MEASUREMENT RESULT: "CTL140702114_fin"

7/2/2014 11:47AM

Frequency MHz	Level dBµV	Transd dB	Limit dBµV	Margin dB	Detector	Line	PE
0.346000	46.60	10.2	59	12.5	QP	N	GND
0.860000	37.90	10.2	56	18.1	QP	N	GND
1.448000	36.90	10.3	56	19.1	QP	N	GND
1.970000	37.40	10.3	56	18.6	QP	N	GND
2.024000	37.10	10.4	56	18.9	QP	N	GND
4.880000	37.70	10.4	56	18.3	QP	N	GND

MEASUREMENT RESULT: "CTL140702114_fin2"

7/2/2014 11:47AM

Frequency MHz	Level dBµV	Transd dB	Limit dBµV	Margin dB	Detector	Line	PE
0.346000	35.10	10.2	49	14.0	AV	N	GND
3.710000	26.10	10.4	46	19.9	AV	N	GND
4.244000	27.10	10.4	46	18.9	AV	N	GND
4.814000	28.50	10.4	46	17.5	AV	N	GND
4.946000	27.00	10.4	46	19.0	AV	N	GND
5.444000	30.40	10.4	50	19.6	AV	N	GND



4.2. Radiated Emission Test

TEST CONFIGURATION

(A) Radiated Emission Test Set-Up, Frequency Below 30MHz

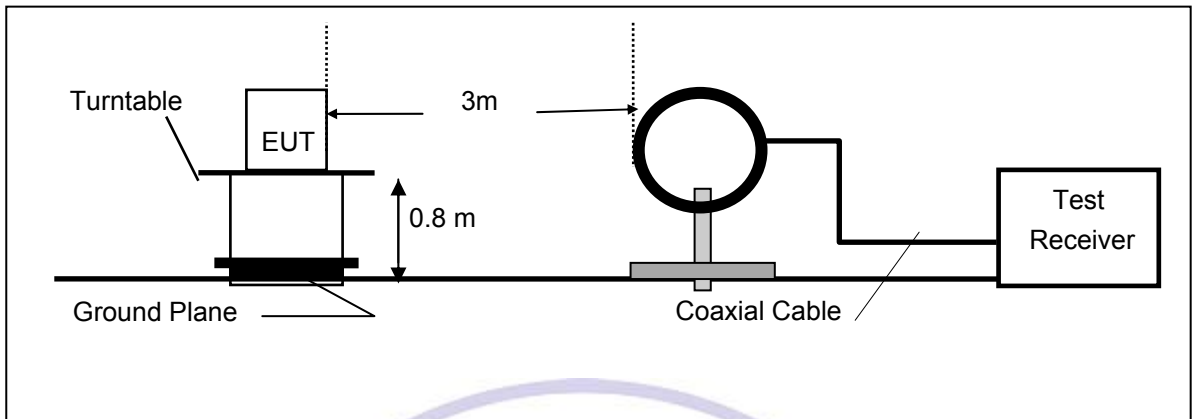

(B) Radiated Emission Test Set-Up, Frequency Below 1000MHz

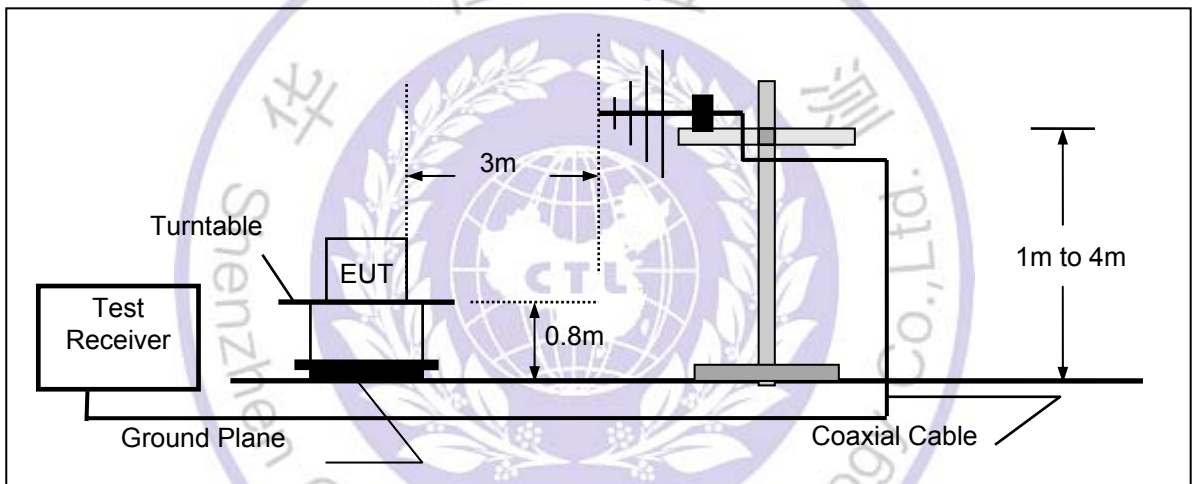

(C) Radiated Emission Test Set-Up, Frequency above 1000MHz

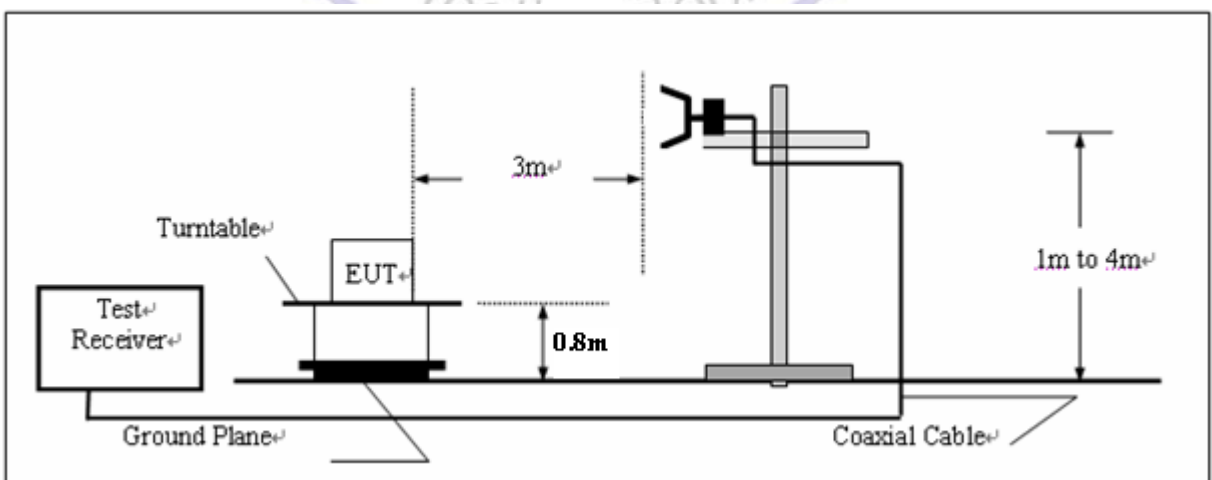

FIELD STRENGTH CALCULATION

The field strength is calculated by adding the Antenna Factor and Cable Factor and subtracting the Amplifier Gain and Duty Cycle Correction Factor(if any) from the measured reading. The basic equation with a sample calculation is as follows:

$$FS = RA + AF + CL - AG$$

Where FS = Field Strength	CL = Cable Attenuation Factor (Cable Loss)
RA = Reading Amplitude	AG = Amplifier Gain
AF = Antenna Factor	

TEST PROCEDURE

1. The testing follows FCC KDB Publication No. 558074 D01 v03r02 (Measurement Guidelines of DTS).
2. The EUT was placed on a turn table which is 0.8m above ground plane.
3. Maximum procedure was performed by raising the receiving antenna from 1m to 4m and rotating the turn table from 0° to 360° to acquire the highest emissions from EUT
4. And also, each emission was to be maximized by changing the polarization of receiving antenna both horizontal and vertical.
5. Span = wide enough to fully capture the emission being measured; RBW = 1 MHz for f > 1 GHz, 100 kHz for f < 1 GHz; VBW ≥ RBW; Sweep = auto; Detector function = peak; Trace = max hold.
6. Repeat above procedures until all frequency measurements have been completed.

Note:

When doing emission measurement above 1GHz, the horn antenna will be bended down a little (as horn antenna has the narrow beamwidth) in order to keeping the antenna in the “cone of radiation” of EUT. The 3dB beamwidth is 60 degrees for H-plane and 90 degrees for E-plane.

LIMIT

For unintentional device, according to § 15.109(a), except for Class A digital devices, the field strength of radiated emissions from unintentional radiators at a distance of 3 meters shall not exceed the following values:

Frequencies (MHz)	Field Strength (micorvolts/meter)	Measurement Distance (meters)
0.009~0.490	2400/F(kHz)	300
0.490~1.705	24000/F(kHz)	30
1.705~30.0	30	30
30~88	100	3
88~216	150	3
216~960	200	3
Above 960	500	3

For intentional device, according to § 15.209(a), the general requirement of field strength of radiated emissions from intentional radiators at a distance of 3 meters shall not exceed the above table. According to § 15.247(d), in any 100kHz bandwidth outside the frequency band in which the EUT is operating, the radio frequency power that is produced by the intentional radiator shall be at least 20dB below that in the 100kHz bandwidth within the band that contains the highest level of desired power.

TEST RESULTS

9KHz-30MHz:

Freq. (MHz)	Level (dBuV)	Over Limit (dB)	Limit Line (dBuV)	Remark
-	-	-	-	See Note

Note: The amplitude of spurious emissions that are attenuated by more than 20dB below the permissible value has no need to be reported.

Distance extrapolation factor= 40 log (specific distance/ test distance) (dB);
 Limit line= specific limits (dBuV) + distance extrapolation factor.

Below 1GHz:

The radiated measurement are performed the each test mode (b/g/n) and channel (low/mid/high), the datum recorded below (802.11b mode, the middle channel) is the worst case for all the test mode and channel.

SWEEP TABLE: "test (30M-1G)"

Short Description:		Field Strength			
Start	Stop	Detector	Meas. Time	IF Bandw.	Transducer
30.0 MHz	1.0 GHz	MaxPeak	300.0 ms	120 kHz	JB1

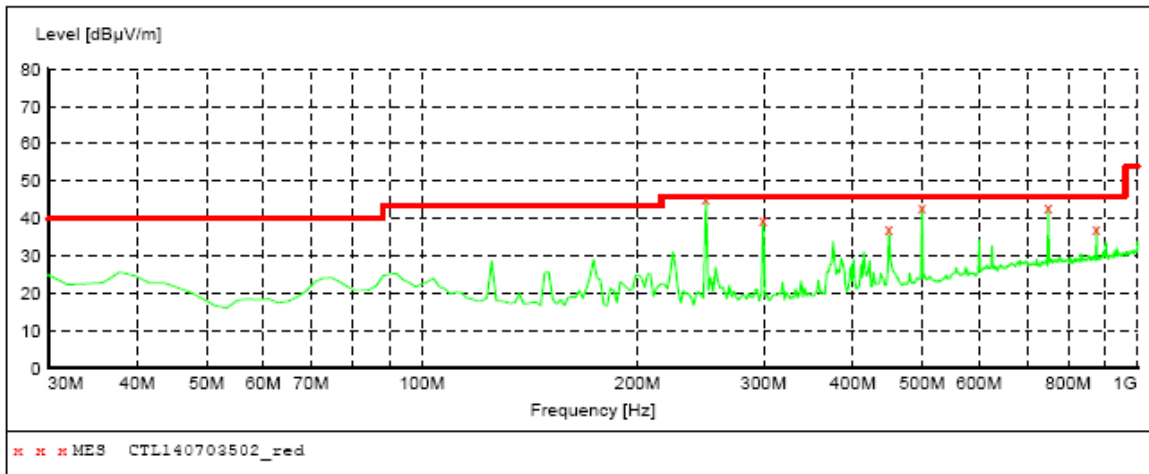

MEASUREMENT RESULT: "CTL140703502_red"

7/03/2014 11:18AM

Frequency MHz	Level dBuV/m	Transd dB	Limit dBuV/m	Margin dB	Det.	Height cm	Azimuth deg	Polarization
249.220000	45.20	14.1	46.0	0.8	---	0.0	0.00	HORIZONTAL
299.660000	39.50	15.4	46.0	6.5	---	0.0	0.00	HORIZONTAL
449.040000	37.40	19.2	46.0	8.6	---	0.0	0.00	HORIZONTAL
499.480000	43.20	20.4	46.0	2.8	---	0.0	0.00	HORIZONTAL
749.740000	43.20	24.3	46.0	2.8	---	0.0	0.00	HORIZONTAL
875.840000	37.40	25.6	46.0	8.6	---	0.0	0.00	HORIZONTAL

SWEEP TABLE: "test (30M-1G)"

Short Description:		Field Strength			
Start	Stop	Detector	Meas. Time	IF Bandw.	Transducer
30.0 MHz	1.0 GHz	MaxPeak	300.0 ms	120 kHz	JB1

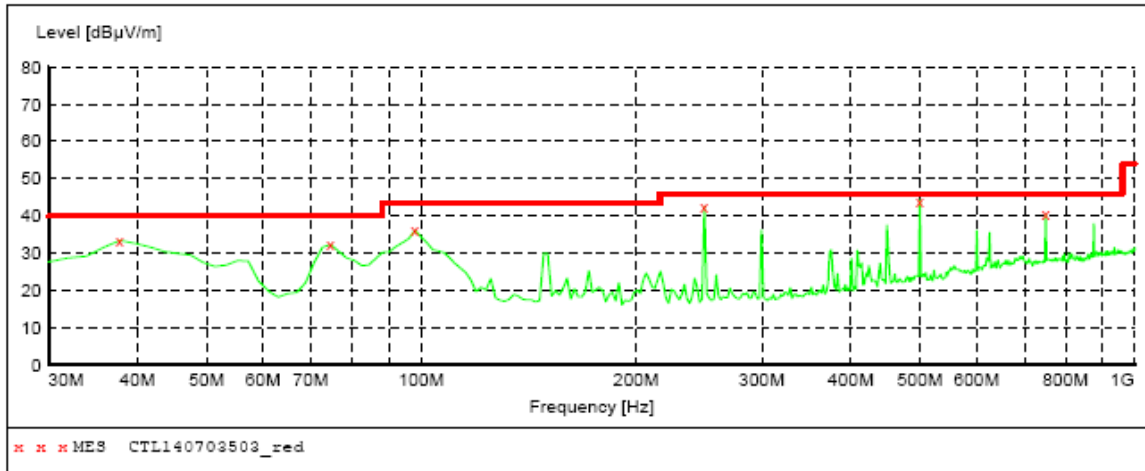

MEASUREMENT RESULT: "CTL140703503_red"

7/03/2014 11:22AM

Frequency MHz	Level dBuV/m	Transd dB	Limit dBuV/m	Margin dB	Det.	Height cm	Azimuth deg	Polarization
37.760000	33.40	15.3	40.0	6.6	---	0.0	0.00	VERTICAL
74.620000	32.30	8.5	40.0	7.7	---	0.0	0.00	VERTICAL
97.900000	36.10	11.1	43.5	7.4	---	0.0	0.00	VERTICAL
249.220000	42.50	14.1	46.0	3.5	---	0.0	0.00	VERTICAL
499.480000	44.20	20.4	46.0	1.8	---	0.0	0.00	VERTICAL
749.740000	40.40	24.3	46.0	5.6	---	0.0	0.00	VERTICAL



**Above 1GHz:
802.11b CH1**

ANTENNA POLARITY & TEST DISTANCE: HORIZONTAL AT 3 M												
No.	Frequency (MHz)	Emission Level (dBuV/m)		Limit (dBuV/m)	Margin (dB)	Antenna Height (m)	Table Angle (Degree)	Raw Value (dBuV)	Antenna Factor (dB/m)	Cable Factor (dB)	Pre-amplifier (dB)	Correction Factor (dB/m)
1	2390.00	50.66	PK	74.00	23.54	1.00 H	200	53.86	28.8	4.60	36.6	-3.20
1	2390.00	38.69	AV	54.00	15.51	1.00 H	200	41.89	28.8	4.60	36.6	-3.20
2	*2412.00	102.89	PK			1.00 H	333	106.09	28.8	4.60	36.6	-3.20
2	*2412.00	88.95	AV			1.00 H	333	92.15	28.8	4.60	36.6	-3.20
3	4824.00	60.12	PK	74.00	13.88	1.00 H	125	56.32	32.7	7.00	36.5	3.80
3	4824.00	50.60	AV	54.00	4.00	1.00 H	125	46.80	32.7	7.00	36.5	3.80
4	7236.00	62.12	PK	74.00	11.88	1.00 H	66	52.72	35.8	8.90	35.3	9.40
4	7236.00	47.23	AV	54.00	6.77	1.00 H	66	37.83	35.8	8.90	35.3	9.40
5	9648.00	64.20	PK	74.00	9.80	1.00 H	264	51.60	37.2	10.20	34.8	12.60
5	9648.00	50.11	AV	54.00	3.89	1.00 H	264	37.51	37.2	10.20	34.8	12.60

ANTENNA POLARITY & TEST DISTANCE: VERTICAL AT 3 M												
No.	Frequency (MHz)	Emission Level (dBuV/m)		Limit (dBuV/m)	Margin (dB)	Antenna Height (m)	Table Angle (Degree)	Raw Value (dBuV)	Antenna Factor (dB/m)	Cable Factor (dB)	Pre-amplifier (dB)	Correction Factor (dB/m)
1	2390.00	51.81	PK	74.00	22.39	1.0	236	55.01	28.8	4.60	36.6	-3.20
1	2390.00	45.18	AV	54.00	9.02	1.0	236	48.38	28.8	4.60	36.6	-3.20
2	*2412.00	112.76	PK			1.0	100	115.96	28.8	4.60	36.6	-3.20
2	*2412.00	107.98	AV			1.0	100	111.18	28.8	4.60	36.6	-3.20
3	4824.00	61.70	PK	74.00	12.90	1.0	312	57.90	32.7	7.00	36.5	3.80
3	4824.00	48.23	AV	54.00	5.77	1.0	312	44.43	32.7	7.00	36.5	3.80
4	7236.00	63.56	PK	74.00	10.44	1.0	46	54.16	35.8	8.90	35.3	9.40
4	7236.00	49.44	AV	54.00	4.56	1.0	46	40.04	35.8	8.90	35.3	9.40
5	9648.00	66.00	PK	74.00	8.00	1.0	108	53.40	37.2	10.20	34.8	12.60
5	9648.00	49.14	AV	54.00	4.86	1.0	108	36.54	37.2	10.20	34.8	12.60

- REMARKS:**
1. Emission level (dBuV/m) = Raw Value (dBuV) + Correction Factor (dB/m)
 2. Correction Factor (dB/m) = Antenna Factor (dB/m) + Cable Factor (dB) - Pre-amplifier Factor
 3. The other emission levels were very low against the limit.
 4. Margin value = Limit value - Emission level.
 5. The limit value is defined as per 15.247
 6. "*" : Fundamental frequency
 7. For Wireless 802.11b mode at 11Mbps.

802.11b CH6

ANTENNA POLARITY & TEST DISTANCE: HORIZONTAL AT 3 M

No.	Frequency (MHz)	Emission Level (dBuV/m)		Limit (dBuV/m)	Margin (dB)	Antenna Height (m)	Table Angle (Degree)	Raw Value (dBuV)	Antenna Factor (dB/m)	Cable Factor (dB)	Pre-amplifier (dB)	Correction Factor (dB/m)
1	*2437.00	103.23	PK			1.00 H	153	106.43	28.3	5.10	-36.6	-3.20
1	*2437.00	92.33	AV			1.00 H	153	95.53	28.3	5.10	-36.6	-3.20
2	4874.00	52.23	PK	74.00	21.77	1.00 H	202	55.43	32.3	7.60	-36.5	3.40
2	4874.00	40.14	AV	54.00	13.86	1.00 H	202	43.34	32.3	7.60	-36.5	3.40
3	7311.00	56.45	PK	74.00	17.55	1.00 H	355	52.65	36.1	8.60	-35.3	9.40
3	7311.00	42.23	AV	54.00	11.77	1.00 H	355	38.43	36.1	8.60	-35.3	9.40
4	9748.00	60.14	PK	74.00	13.86	1.00 H	28	50.74	37.2	10.20	-34.8	12.60
4	9748.00	48.14	AV	54.00	5.86	1.00 H	28	38.74	37.2	10.20	-34.8	12.60

ANTENNA POLARITY & TEST DISTANCE: VERTICAL AT 3 M

No.	Frequency (MHz)	Emission Level (dBuV/m)		Limit (dBuV/m)	Margin (dB)	Antenna Height (m)	Table Angle (Degree)	Raw Value (dBuV)	Antenna Factor (dB/m)	Cable Factor (dB)	Pre-amplifier (dB)	Correction Factor (dB/m)
1	*2437.00	109.23	PK			1.00 V	121	112.43	28.3	5.10	-36.6	-3.20
1	*2437.00	98.12	AV			1.00 V	121	101.32	28.3	5.10	-36.6	-3.20
2	4874.00	55.44	PK	74.00	18.56	1.00 V	97	58.64	32.3	7.60	-36.5	3.40
2	4874.00	46.17	AV	54.00	7.83	1.00 V	97	49.37	32.3	7.60	-36.5	3.40
3	7311.00	57.23	PK	74.00	16.77	1.00 V	288	53.43	36.1	8.60	-35.3	9.40
3	7311.00	49.10	AV	54.00	4.90	1.00 V	288	45.30	36.1	8.60	-35.3	9.40
4	9748.00	59.36	PK	74.00	14.64	1.00 V	89	49.96	37.2	10.20	-34.8	12.60
4	9748.00	49.20	AV	54.00	4.80	1.00 V	89	39.80	37.2	10.20	-34.8	12.60

- REMARKS:**
1. Emission level (dBuV/m)=Raw Value(dBuV) + Correction Factor(dB/m)
 2. Correction Factor (dB/m) = Antenna Factor (dB/m) + Cable Factor (dB) + Pre-amplifier Factor
 3. The other emission levels were very low against the limit.
 4. Margin value = Limit value- Emission level.
 5. The limit value is defined as per 15.247
 6. "*" : Fundamental frequency
 7. For Wireless 802.11b mode at 11Mbps.

802.11b CH11

ANTENNA POLARITY & TEST DISTANCE: HORIZONTAL AT 3 M

No.	Frequency (MHz)	Emission Level (dBuV/m)		Limit (dBuV/m)	Margin (dB)	Antenna Height (m)	Table Angle (Degree)	Raw Value (dBuV)	Antenna Factor (dB/m)	Cable Factor (dB)	Pre-amplifier (dB)	Correction Factor (dB/m)
1	*2462.00	103.35	PK			1.00 H	154	106.35	28.9	4.70	-36.6	-3.00
1	*2462.00	92.99	AV			1.00 H	154	95.99	28.9	4.70	-36.6	-3.00
2	2483.50	49.48	PK	74.00	24.52	1.00 H	146	52.48	28.9	4.70	-36.6	-3.00
2	2483.50	38.43	AV	54.00	15.57	1.00 H	146	41.43	28.9	4.70	-36.6	-3.00
3	4022.04	56.12	PK	74.00	17.88	1.00 H	341	54.22	32.2	6.20	-36.5	1.90
3	4022.04	49.01	AV	54.00	4.99	1.00 H	341	47.11	32.2	6.20	-36.5	1.90
4	4924.00	54.63	PK	74.00	19.37	1.00 H	100	50.83	33.0	7.00	-36.2	3.80
4	4924.00	45.11	AV	54.00	8.89	1.00 H	100	41.31	33.0	7.00	-36.2	3.80
5	7386.00	59.00	PK	74.00	15.00	1.00 H	190	49.60	36.2	8.50	-35.3	9.40
5	7386.00	48.03	AV	54.00	5.97	1.00 H	190	38.63	36.2	8.50	-35.3	9.40
6	9848.00	60.22	PK	74.00	13.78	1.00 H	113	47.62	37.2	10.20	-34.8	12.60
6	9848.00	50.07	AV	54.00	3.93	1.00 H	113	37.47	37.2	10.20	-34.8	12.60

ANTENNA POLARITY & TEST DISTANCE: VERTICAL AT 3 M

No.	Frequency (MHz)	Emission Level (dBuV/m)		Limit (dBuV/m)	Margin (dB)	Antenna Height (m)	Table Angle (Degree)	Raw Value (dBuV)	Antenna Factor (dB/m)	Cable Factor (dB)	Pre-amplifier (dB)	Correction Factor (dB/m)
1	*2462.00	113.06	PK			1.00 V	247	116.06	28.9	4.70	-36.6	-3.00
1	*2462.00	107.69	AV			1.00 V	247	110.69	28.9	4.70	-36.6	-3.00
2	2483.50	51.86	PK	74.00	22.14	1.00 V	150	54.86	28.9	4.70	-36.6	-3.00
2	2483.50	46.52	AV	54.00	7.48	1.00 V	150	49.52	28.9	4.70	-36.6	-3.00
3	4022.04	52.02	PK	74.00	21.98	1.00 V	299	50.12	32.2	6.20	-36.5	1.90
3	4022.04	44.11	AV	54.00	9.89	1.00 V	299	42.21	32.2	6.20	-36.5	1.90
4	4924.00	54.00	PK	74.00	20.00	1.00 V	90	50.20	33.0	7.00	-36.2	3.80
4	4924.00	43.14	AV	54.00	10.86	1.00 V	90	39.34	33.0	7.00	-36.2	3.80
5	7386.00	58.88	PK	74.00	15.12	1.00 V	29	49.48	36.2	8.50	-35.3	9.40
5	7386.00	46.61	AV	54.00	7.39	1.00 V	29	37.21	36.2	8.50	-35.3	9.40
6	9848.00	60.00	PK	74.00	14.00	1.00 V	222	47.40	37.2	10.20	-34.8	12.60
6	9848.00	49.23	AV	54.00	4.77	1.00 V	222	36.63	37.2	10.20	-34.8	12.60

- REMARKS:**
1. Emission level (dBuV/m)=Raw Value(dBuV) + Correction Factor(dB/m)
 2. Correction Factor (dB/m) = Antenna Factor (dB/m) + Cable Factor (dB))+ Pre-amplifier Factor
 3. The other emission levels were very low against the limit.
 4. Margin value = Limit value- Emission level.
 5. The limit value is defined as per 15.247
 6. "*" : Fundamental frequency
 7. For Wireless 802.11b mode at 11Mbps.

802.11g CH1

ANTENNA POLARITY & TEST DISTANCE: HORIZONTAL AT 3 M

No.	Frequency (MHz)	Emission Level (dBuV/m)		Limit (dBuV/m)	Margin (dB)	Antenna Height (m)	Table Angle (Degree)	Raw Value (dBuV)	Antenna Factor (dB/m)	Cable Factor (dB)	Pre-amplifier (dB)	Correction Factor (dB/m)
1	2390.00	61.33	PK	74.00	12.67	1.00 H	247	64.33	28.8	4.60	36.6	-3.20
1	2390.00	44.54	AV	54.00	9.46	1.00 H	247	47.54	28.8	4.60	36.6	-3.20
2	*2412.00	100.32	PK			1.00 H	100	103.32	28.8	4.60	36.6	-3.20
2	*2412.00	84.74	AV			1.00 H	100	87.74	28.8	4.60	36.6	-3.20
3	4824.00	58.14	PK	74.00	15.86	1.00 H	89	56.24	32.7	7.30	36.2	3.80
3	4824.00	47.96	AV	54.00	6.04	1.00 H	89	46.06	32.7	7.30	36.2	3.80
4	7236.00	62.22	PK	74.00	11.78	1.00 H	345	58.42	35.8	8.90	35.3	9.40
4	7236.00	48.60	AV	54.00	5.40	1.00 H	345	44.80	35.8	8.90	35.3	9.40
5	9648.00	64.17	PK	74.00	9.83	1.00 H	121	54.77	37.2	10.20	34.8	12.60
5	9648.00	50.25	AV	54.00	3.75	1.00 H	121	40.85	37.2	10.20	34.8	12.60

ANTENNA POLARITY & TEST DISTANCE: VERTICAL AT 3 M

No.	Frequency (MHz)	Emission Level (dBuV/m)		Limit (dBuV/m)	Margin (dB)	Antenna Height (m)	Table Angle (Degree)	Raw Value (dBuV)	Antenna Factor (dB/m)	Cable Factor (dB)	Pre-amplifier (dB)	Correction Factor (dB/m)
1	2390.00	69.66	PK	74.00	4.34	1.00 V	288	72.66	28.8	4.60	36.6	-3.20
1	2390.00	50.63	AV	54.00	3.37	1.00 V	288	53.63	28.8	4.60	36.6	-3.20
2	*2412.00	110.40	PK			1.00 V	69	113.40	28.8	4.60	36.6	-3.20
2	*2412.00	94.98	AV			1.00 V	69	97.98	28.8	4.60	36.6	-3.20
3	4824.00	58.88	PK	74.00	15.12	1.00 V	291	56.98	32.7	7.30	36.2	3.80
3	4824.00	46.99	AV	54.00	7.01	1.00 V	291	45.09	32.7	7.30	36.2	3.80
4	7236.00	61.44	PK	74.00	12.56	1.00 V	360	57.64	35.8	8.90	35.3	9.40
4	7236.00	48.00	AV	54.00	6.00	1.00 V	360	44.20	35.8	8.90	35.3	9.40
5	9648.00	65.22	PK	74.00	8.78	1.00 V	155	55.82	37.2	10.20	34.8	12.60
5	9648.00	50.47	AV	54.00	3.53	1.00 V	155	41.07	37.2	10.20	34.8	12.60

- REMARKS:**
1. Emission level (dBuV/m)=Raw Value(dBuV) + Correction Factor(dB/m)
 2. Correction Factor (dB/m) = Antenna Factor (dB/m) + Cable Factor (dB) + Pre-amplifier Factor
 3. The other emission levels were very low against the limit.
 4. Margin value = Limit value- Emission level.
 5. The limit value is defined as per 15.247
 6. "*" : Fundamental frequency
 7. For Wireless 802.11g mode at 54Mbps.

802.11g CH6

ANTENNA POLARITY & TEST DISTANCE: HORIZONTAL AT 3 M

No.	Frequency (MHz)	Emission Level (dBuV/m)		Limit (dBuV/m)	Margin (dB)	Antenna Height (m)	Table Angle (Degree)	Raw Value (dBuV)	Antenna Factor (dB/m)	Cable Factor (dB)	Pre-amplifier (dB)	Correction Factor (dB/m)
1	*2437.00	105.25	PK			1.00 H	100	108.45	28.3	5.10	-36.6	-3.20
1	*2437.00	96.00	AV			1.00 H	100	99.20	28.3	5.10	-36.6	-3.20
2	4874.00	56.50	PK	74.00	17.50	1.00 H	214	53.10	32.8	7.10	-36.5	3.40
2	4874.00	47.23	AV	54.00	6.77	1.00 H	214	43.83	32.8	7.10	-36.5	3.40
3	7311.00	57.70	PK	74.00	16.30	1.00 H	0	48.30	36.1	8.60	-35.3	9.40
3	7311.00	48.60	AV	54.00	5.40	1.00 H	0	39.20	36.1	8.60	-35.3	9.40
4	9748.00	59.63	PK	74.00	14.37	1.00 H	163	47.03	37.2	10.20	-34.8	12.60
4	9748.00	49.50	AV	54.00	4.50	1.00 H	163	36.90	37.2	10.20	-34.8	12.60

ANTENNA POLARITY & TEST DISTANCE: VERTICAL AT 3 M

No.	Frequency (MHz)	Emission Level (dBuV/m)		Limit (dBuV/m)	Margin (dB)	Antenna Height (m)	Table Angle (Degree)	Raw Value (dBuV)	Antenna Factor (dB/m)	Cable Factor (dB)	Pre-amplifier (dB)	Correction Factor (dB/m)
1	*2437.00	109.50	PK			1.00 V	122	112.70	28.3	5.10	-36.6	-3.20
1	*2437.00	98.80	AV			1.00 V	122	102.00	28.3	5.10	-36.6	-3.20
2	4874.00	56.90	PK	74.00	17.10	1.00 V	100	53.50	32.8	7.10	-36.5	3.40
2	4874.00	45.45	AV	54.00	8.55	1.00 V	100	42.05	32.8	7.10	-36.5	3.40
3	7311.00	58.17	PK	74.00	15.83	1.00 V	356	48.77	36.1	8.60	-35.3	9.40
3	7311.00	48.65	AV	54.00	5.35	1.00 V	356	39.25	36.1	8.60	-35.3	9.40
4	9748.00	60.58	PK	74.00	13.42	1.00 V	26	47.98	37.2	10.20	-34.8	12.60
4	9748.00	49.20	AV	54.00	4.80	1.00 V	26	36.60	37.2	10.20	-34.8	12.60

- REMARKS:**
1. Emission level (dBuV/m) = Raw Value (dBuV) + Correction Factor (dB/m)
 2. Correction Factor (dB/m) = Antenna Factor (dB/m) + Cable Factor (dB) + Pre-amplifier Factor
 3. The other emission levels were very low against the limit.
 4. Margin value = Limit value - Emission level.
 5. The limit value is defined as per 15.247
 6. "*" : Fundamental frequency
 7. For Wireless 802.11g mode at 54Mbps.

802.11g CH11

ANTENNA POLARITY & TEST DISTANCE: HORIZONTAL AT 3 M

No.	Frequency (MHz)	Emission Level (dBUV/m)		Limit (dBUV/m)	Margin (dB)	Antenna Height (m)	Table Angle (Degree)	Raw Value (dBUV)	Antenna Factor (dB/m)	Cable Factor (dB)	Pre-amplifier (dB)	Correction Factor (dB/m)
1	*2462.00	100.21	PK			1.00 H	156	103.21	28.9	4.70	-36.6	-3.00
1	*2462.00	84.73	AV			1.00 H	156	87.73	28.9	4.70	-36.6	-3.00
2	2483.50	59.39	PK	74.00	14.61	1.00 H	191	62.39	28.9	4.70	-36.6	-3.00
2	2483.50	42.28	AV	54.00	11.72	1.00 H	191	45.28	28.9	4.70	-36.6	-3.00
3	4924.00	54.26	PK	74.00	19.74	1.00 H	198	50.46	33.0	7.00	-36.2	3.80
3	4924.00	45.22	AV	54.00	8.78	1.00 H	198	41.42	33.0	7.00	-36.2	3.80
4	7386.00	57.36	PK	74.00	16.64	1.00 H	90	47.96	36.2	8.50	-35.3	9.40
4	7386.00	46.65	AV	54.00	7.35	1.00 H	90	37.25	36.2	8.50	-35.3	9.40
5	9848.00	60.14	PK	74.00	13.86	1.00 H	124	47.54	37.3	10.10	-34.8	12.60
5	9848.00	50.00	AV	54.00	4.00	1.00 H	124	37.40	37.3	10.10	-34.8	12.60

ANTENNA POLARITY & TEST DISTANCE: VERTICAL AT 3 M

No.	Frequency (MHz)	Emission Level (dBUV/m)		Limit (dBUV/m)	Margin (dB)	Antenna Height (m)	Table Angle (Degree)	Raw Value (dBUV)	Antenna Factor (dB/m)	Cable Factor (dB)	Pre-amplifier (dB)	Correction Factor (dB/m)
1	*2462.00	106.70	PK			1.00 V	125	109.70	28.9	4.70	-36.6	-3.00
1	*2462.00	94.49	AV			1.00 V	125	97.49	28.9	4.70	-36.6	-3.00
2	2483.50	66.73	PK	74.00	7.27	1.00 V	348	69.73	28.9	4.70	-36.6	-3.00
2	2483.50	50.92	AV	54.00	3.08	1.00 V	348	53.92	28.9	4.70	-36.6	-3.00
3	4924.00	56.11	PK	74.00	17.89	1.00 V	96	52.31	33.0	7.00	-36.2	3.80
3	4924.00	47.82	AV	54.00	6.18	1.00 V	96	44.02	33.0	7.00	-36.2	3.80
4	7386.00	56.24	PK	74.00	17.76	1.00 V	35	46.84	36.2	8.50	-35.3	9.40
4	7386.00	45.00	AV	54.00	9.00	1.00 V	35	35.60	36.2	8.50	-35.3	9.40
5	9848.00	60.00	PK	74.00	14.00	1.00 V	37	47.40	37.3	10.10	-34.8	12.60
5	9848.00	50.26	AV	54.00	3.74	1.00 V	37	37.66	37.3	10.10	-34.8	12.60

- REMARKS:**
1. Emission level (dBUV/m) = Raw Value (dBUV) + Correction Factor (dB/m)
 2. Correction Factor (dB/m) = Antenna Factor (dB/m) + Cable Factor (dB) + Pre-amplifier Factor
 3. The other emission levels were very low against the limit.
 4. Margin value = Limit value - Emission level.
 5. The limit value is defined as per 15.247
 6. " * " : Fundamental frequency
 7. For Wireless 802.11g mode at 54Mbps.

802.11n (20MHz) Channel 1

ANTENNA POLARITY & TEST DISTANCE: HORIZONTAL AT 3 M

No.	Frequency (MHz)	Emission Level (dBuV/m)		Limit (dBuV/m)	Margin (dB)	Antenna Height (m)	Table Angle (Degree)	Raw Value (dBuV)	Antenna Factor (dB/m)	Cable Factor (dB)	Pre-amplifier (dB)	Correction Factor (dB/m)
1	2390.00	56.96	PK	74.00	17.04	1.00 H	144	60.16	28.8	4.60	36.6	-3.20
1	2390.00	44.33	AV	54.00	9.67	1.00 H	144	47.53	28.8	4.60	36.6	-3.20
2	*2412.00	98.38	PK			1.00 H	256	101.58	28.8	4.60	36.6	-3.20
2	*2412.00	81.55	AV			1.00 H	256	84.75	28.8	4.60	36.6	-3.20
3	4824.00	48.25	PK	74.00	25.75	1.00 H	88	44.45	32.7	7.30	36.2	3.80
3	4824.00	40.00	AV	54.00	14.00	1.00 H	88	36.20	32.7	7.30	36.2	3.80
4	7236.00	54.36	PK	74.00	19.64	1.00 H	331	44.96	35.8	8.90	35.3	9.40
4	7236.00	45.22	AV	54.00	8.78	1.00 H	331	35.82	35.8	8.90	35.3	9.40
5	9648.00	59.68	PK	74.00	14.32	1.00 H	105	47.08	37.2	10.20	34.8	12.60
5	9648.00	49.25	AV	54.00	4.75	1.00 H	105	36.65	37.2	10.20	34.8	12.60

ANTENNA POLARITY & TEST DISTANCE: VERTICAL AT 3 M

No.	Frequency (MHz)	Emission Level (dBuV/m)		Limit (dBuV/m)	Margin (dB)	Antenna Height (m)	Table Angle (Degree)	Raw Value (dBuV)	Antenna Factor (dB/m)	Cable Factor (dB)	Pre-amplifier (dB)	Correction Factor (dB/m)
1	2390.00	69.20	PK	74.00	4.80	1.00 V	125	72.40	28.8	4.60	36.6	-3.20
1	2390.00	50.90	AV	54.00	3.10	1.00 V	125	54.10	28.8	4.60	36.6	-3.20
2	*2412.00	112.09	PK			1.00 V	236	115.29	28.8	4.60	36.6	-3.20
2	*2412.00	95.33	AV			1.00 V	236	98.53	28.8	4.60	36.6	-3.20
3	4824.00	50.23	PK	74.00	23.77	1.00 V	179	46.43	32.7	7.30	36.2	3.80
3	4824.00	42.02	AV	54.00	11.98	1.00 V	179	38.22	32.7	7.30	36.2	3.80
4	7236.00	56.96	PK	74.00	17.04	1.00 V	313	47.56	35.8	8.90	35.3	9.40
4	7236.00	46.74	AV	54.00	7.26	1.00 V	313	37.34	35.8	8.90	35.3	9.40
5	9648.00	60.23	PK	74.00	13.77	1.00 V	5	47.63	37.2	10.20	34.8	12.60
5	9648.00	50.08	AV	54.00	3.92	1.00 V	5	37.48	37.2	10.20	34.8	12.60

- REMARKS:**
1. Emission level (dBuV/m)=Raw Value(dBuV) + Correction Factor(dB/m)
 2. Correction Factor (dB/m) = Antenna Factor (dB/m) + Cable Factor (dB) -Pre-amplifier Factor
 3. The other emission levels were very low against the limit.
 4. Margin value = Limit value- Emission level.
 5. The limit value is defined as per 15.247
 6. "*" : Fundamental frequency

802.11n (20MHz) Channel 6

ANTENNA POLARITY & TEST DISTANCE: HORIZONTAL AT 3 M

No.	Frequency (MHz)	Emission Level (dBuV/m)		Limit (dBuV/m)	Margin (dB)	Antenna Height (m)	Table Angle (Degree)	Raw Value (dBuV)	Antenna Factor (dB/m)	Cable Factor (dB)	Pre-amplifier (dB)	Correction Factor (dB/m)
1	*2437.00	102.55	PK			1.00 H	223	105.75	28.3	5.10	36.6	-3.20
1	*2437.00	89.47	AV			1.00 H	122	92.67	28.3	5.10	36.6	-3.20
2	4874.00	56.14	PK	74.00	17.86	1.00 H	5	52.74	32.8	7.10	36.5	3.40
2	4874.00	47.58	AV	54.00	6.42	1.00 H	5	44.18	32.8	7.10	36.5	3.40
3	7311.00	58.67	PK	74.00	15.33	1.00 H	124	49.27	36.1	8.60	35.3	9.40
3	7311.00	46.11	AV	54.00	7.89	1.00 H	124	36.71	36.1	8.60	35.3	9.40
4	9748.00	60.56	PK	74.00	13.44	1.00 H	325	47.96	37.2	10.20	34.8	12.60
4	9748.00	49.98	AV	54.00	4.02	1.00 H	325	37.38	37.2	10.20	34.8	12.60

ANTENNA POLARITY & TEST DISTANCE: VERTICAL AT 3 M

No.	Frequency (MHz)	Emission Level (dBuV/m)		Limit (dBuV/m)	Margin (dB)	Antenna Height (m)	Table Angle (Degree)	Raw Value (dBuV)	Antenna Factor (dB/m)	Cable Factor (dB)	Pre-amplifier (dB)	Correction Factor (dB/m)
1	*2437.00	107.64	PK			1.00 V	125	110.84	28.3	5.10	36.6	-3.20
1	*2437.00	95.47	AV			1.00 V	125	98.67	28.3	5.10	36.6	-3.20
2	4874.00	55.63	PK	74.00	18.37	1.00 V	289	52.23	32.8	7.10	36.5	3.40
2	4874.00	46.85	AV	54.00	7.15	1.00 V	289	43.45	32.8	7.10	36.5	3.40
3	7311.00	58.55	PK	74.00	15.45	1.00 V	0	49.15	36.1	8.60	35.3	9.40
3	7311.00	47.82	AV	54.00	6.18	1.00 V	0	38.42	36.1	8.60	35.3	9.40
4	9748.00	60.28	PK	74.00	13.72	1.00 V	180	47.68	37.2	10.20	34.8	12.60
4	9748.00	50.25	AV	54.00	3.75	1.00 V	180	37.65	37.2	10.20	34.8	12.60

- REMARKS:**
1. Emission level (dBuV/m) = Raw Value (dBuV) + Correction Factor (dB/m)
 2. Correction Factor (dB/m) = Antenna Factor (dB/m) + Cable Factor (dB) - Pre-amplifier Factor
 3. The other emission levels were very low against the limit.
 4. Margin value = Limit value - Emission level.
 5. The limit value is defined as per 15.247
 6. "*" : Fundamental frequency

802.11n (20MHz) Channel 11

ANTENNA POLARITY & TEST DISTANCE: HORIZONTAL AT 3 M

No.	Frequency (MHz)	Emission Level (dBuV/m)		Limit (dBuV/m)	Margin (dB)	Antenna Height (m)	Table Angle (Degree)	Raw Value (dBuV)	Antenna Factor (dB/m)	Cable Factor (dB)	Pre-amplifier (dB)	Correction Factor (dB/m)
1	*2462.00	99.01	PK			1.00 H	122	102.01	28.9	4.70	-36.6	-3.00
1	*2462.00	82.48	AV			1.00 H	122	85.48	28.9	4.70	-36.6	-3.00
2	2483.50	60.79	PK	74.00	13.21	1.00 H	300	63.79	28.9	4.70	-36.6	-3.00
2	2483.50	43.98	AV	54.00	10.02	1.00 H	300	46.98	28.9	4.70	-36.6	-3.00
3	4924.00	54.55	PK	74.00	19.45	1.00 H	156	50.75	33.0	7.00	36.2	3.80
3	4924.00	40.29	AV	54.00	13.71	1.00 H	156	36.49	33.0	7.00	36.2	3.80
4	7386.00	58.00	PK	74.00	16.00	1.00 H	334	48.60	36.2	8.50	35.3	9.40
4	7386.00	47.69	AV	54.00	6.31	1.00 H	334	38.29	36.2	8.50	35.3	9.40
5	9848.00	61.23	PK	74.00	12.77	1.00 H	278	48.63	37.3	10.10	34.8	12.60
5	9848.00	50.07	AV	54.00	3.93	1.00 H	278	37.47	37.3	10.10	34.8	12.60

ANTENNA POLARITY & TEST DISTANCE: VERTICAL AT 3 M

No.	Frequency (MHz)	Emission Level (dBuV/m)		Limit (dBuV/m)	Margin (dB)	Antenna Height (m)	Table Angle (Degree)	Raw Value (dBuV)	Antenna Factor (dB/m)	Cable Factor (dB)	Pre-amplifier (dB)	Correction Factor (dB/m)
1	*2462.00	112.80	PK			1.00 V	125	115.80	28.9	4.70	-36.6	-3.00
1	*2462.00	92.96	AV			1.00 V	125	95.96	28.9	4.70	-36.6	-3.00
2	2483.50	70.05	PK	74.00	3.95	1.00 V	189	73.05	28.9	4.70	-36.6	-3.00
2	2483.50	50.24	AV	54.00	3.76	1.00 V	189	53.24	28.9	4.70	-36.6	-3.00
3	4924.00	56.26	PK	74.00	17.74	1.00 V	347	52.46	33.0	7.00	36.2	3.80
3	4924.00	48.11	AV	54.00	5.89	1.00 V	347	44.31	33.0	7.00	36.2	3.80
4	7386.00	58.23	PK	74.00	15.77	1.00 V	12	48.83	36.2	8.50	35.3	9.40
4	7386.00	47.63	AV	54.00	6.37	1.00 V	12	38.23	36.2	8.50	35.3	9.40
5	9848.00	60.12	PK	74.00	13.88	1.00 V	208	47.52	37.3	10.10	34.8	12.60
5	9848.00	50.07	AV	54.00	3.93	1.00 V	208	37.47	37.3	10.10	34.8	12.60

- REMARKS:**
1. Emission level (dBuV/m) = Raw Value (dBuV) + Correction Factor (dB/m)
 2. Correction Factor (dB/m) = Antenna Factor (dB/m) + Cable Factor (dB) - Pre-amplifier Factor
 3. The other emission levels were very low against the limit.
 4. Margin value = Limit value - Emission level.
 5. The limit value is defined as per 15.247
 6. " * " : Fundamental frequency

802.11n (40MHz) Channel 3

ANTENNA POLARITY & TEST DISTANCE: HORIZONTAL AT 3 M

No.	Frequency (MHz)	Emission Level (dBuV/m)		Limit (dBuV/m)	Margin (dB)	Antenna Height (m)	Table Angle (Degree)	Raw Value (dBuV)	Antenna Factor (dB/m)	Cable Factor (dB)	Pre-amplifier (dB)	Correction Factor (dB/m)
1	2390.00	59.53	PK	74.00	14.47	1.00 H	236	62.73	28.8	4.60	36.6	-3.20
1	2390.00	42.51	AV	54.00	11.49	1.00 H	236	45.71	28.8	4.60	36.6	-3.20
2	*2422.00	94.02	PK			1.00 H	100	97.22	28.8	4.60	36.6	-3.20
2	*2422.00	75.18	AV			1.00 H	100	78.38	28.8	4.60	36.6	-3.20
3	4844.00	54.98	PK	74.00	19.02	1.00 H	197	51.18	32.7	7.30	36.2	3.80
3	4844.00	40.11	AV	54.00	13.89	1.00 H	197	36.31	32.7	7.30	36.2	3.80
4	7266.00	58.36	PK	74.00	15.64	1.00 H	306	48.96	35.8	8.90	35.3	9.40
4	7266.00	47.25	AV	54.00	6.75	1.00 H	306	37.85	35.8	8.90	35.3	9.40
5	9688.00	60.00	PK	74.00	14.00	1.00 H	17	47.40	37.2	10.20	34.8	12.60
5	9688.00	49.00	AV	54.00	5.00	1.00 H	17	36.40	37.2	10.20	34.8	12.60

ANTENNA POLARITY & TEST DISTANCE: VERTICAL AT 3 M

No.	Frequency (MHz)	Emission Level (dBuV/m)		Limit (dBuV/m)	Margin (dB)	Antenna Height (m)	Table Angle (Degree)	Raw Value (dBuV)	Antenna Factor (dB/m)	Cable Factor (dB)	Pre-amplifier (dB)	Correction Factor (dB/m)
1	2390.00	70.83	PK	74.00	3.17	1.00 V	122	74.03	28.8	4.60	36.6	-3.20
1	2390.00	50.46	AV	54.00	3.54	1.00 V	122	53.66	28.8	4.60	36.6	-3.20
2	*2422.00	108.32	PK			1.00 V	189	111.52	28.8	4.60	36.6	-3.20
2	*2422.00	90.93	AV			1.00 V	189	94.13	28.8	4.60	36.6	-3.20
3	4844.00	56.03	PK	74.00	17.97	1.00 V	257	52.23	32.7	7.30	36.2	3.80
3	4844.00	45.11	AV	54.00	8.89	1.00 V	257	41.31	32.7	7.30	36.2	3.80
4	7266.00	58.69	PK	74.00	15.31	1.00 V	155	49.29	35.8	8.90	35.3	9.40
4	7266.00	47.82	AV	54.00	6.18	1.00 V	155	38.42	35.8	8.90	35.3	9.40
5	9688.00	60.56	PK	74.00	13.44	1.00 V	334	47.96	37.2	10.20	34.8	12.60
5	9688.00	50.04	AV	54.00	3.96	1.00 V	334	37.44	37.2	10.20	34.8	12.60

- REMARKS:**
1. Emission level (dBuV/m)=Raw Value(dBuV) + Correction Factor(dB/m)
 2. Correction Factor (dB/m) = Antenna Factor (dB/m) + Cable Factor (dB) -Pre-amplifier Factor
 3. The other emission levels were very low against the limit.
 4. Margin value = Limit value- Emission level.
 5. The limit value is defined as per 15.247
 6. "*" : Fundamental frequency

802.11n (40MHz) Channel 6

ANTENNA POLARITY & TEST DISTANCE: HORIZONTAL AT 3 M

No.	Frequency (MHz)	Emission Level (dBuV/m)		Limit (dBuV/m)	Margin (dB)	Antenna Height (m)	Table Angle (Degree)	Raw Value (dBuV)	Antenna Factor (dB/m)	Cable Factor (dB)	Pre-amplifier (dB)	Correction Factor (dB/m)
1	*2437.00	99.15	PK			1.00 H	100	102.35	28.3	5.10	36.6	-3.20
1	*2437.00	84.36	AV			1.00 H	100	87.56	28.3	5.10	36.6	-3.20
2	4874.00	55.89	PK	74.00	18.11	1.00 H	198	52.49	32.3	7.60	36.5	3.40
2	4874.00	46.23	AV	54.00	7.77	1.00 H	198	42.83	32.3	7.60	36.5	3.40
3	7311.00	57.85	PK	74.00	16.15	1.00 H	203	48.45	36.1	8.60	35.3	9.40
3	7311.00	46.89	AV	54.00	7.11	1.00 H	203	37.49	36.1	8.60	35.3	9.40
4	9748.00	60.91	PK	74.00	13.09	1.00 H	56	48.31	37.2	10.20	34.8	12.60
4	9748.00	50.17	AV	54.00	3.83	1.00 H	56	37.57	37.2	10.20	34.8	12.60

ANTENNA POLARITY & TEST DISTANCE: VERTICAL AT 3 M

No.	Frequency (MHz)	Emission Level (dBuV/m)		Limit (dBuV/m)	Margin (dB)	Antenna Height (m)	Table Angle (Degree)	Raw Value (dBuV)	Antenna Factor (dB/m)	Cable Factor (dB)	Pre-amplifier (dB)	Correction Factor (dB/m)
1	*2437.00	109.14	PK			1.00 V	122	112.34	28.3	5.10	36.6	-3.20
1	*2437.00	96.51	AV			1.00 V	122	99.71	28.3	5.10	36.6	-3.20
2	4874.00	55.99	PK	74.00	18.01	1.00 V	96	52.59	32.3	7.60	36.5	3.40
2	4874.00	46.97	AV	54.00	7.03	1.00 V	96	43.57	32.3	7.60	36.5	3.40
3	7311.00	57.36	PK	74.00	16.64	1.00 V	26	47.96	36.1	8.60	35.3	9.40
3	7311.00	46.57	AV	54.00	7.43	1.00 V	26	37.17	36.1	8.60	35.3	9.40
4	9748.00	60.79	PK	74.00	13.21	1.00 V	299	48.19	37.2	10.20	34.8	12.60
4	9748.00	50.07	AV	54.00	3.93	1.00 V	299	37.47	37.2	10.20	34.8	12.60

- REMARKS:**
1. Emission level (dBuV/m) = Raw Value (dBuV) + Correction Factor (dB/m)
 2. Correction Factor (dB/m) = Antenna Factor (dB/m) + Cable Factor (dB) - Pre-amplifier Factor
 3. The other emission levels were very low against the limit.
 4. Margin value = Limit value - Emission level.
 5. The limit value is defined as per 15.247
 6. "*" : Fundamental frequency

802.11n (40MHz) Channel 9

ANTENNA POLARITY & TEST DISTANCE: HORIZONTAL AT 3 M

No.	Frequency (MHz)	Emission Level (dBuV/m)		Limit (dBuV/m)	Margin (dB)	Antenna Height (m)	Table Angle (Degree)	Raw Value (dBuV)	Antenna Factor (dB/m)	Cable Factor (dB)	Pre-amplifier (dB)	Correction Factor (dB/m)
1	*2452.00	97.62	PK			1.00 H	125	100.62	28.9	4.70	-36.6	-3.00
1	*2452.00	79.66	AV			1.00 H	125	82.66	28.9	4.70	-36.6	-3.00
2	2483.50	63.38	PK	74.00	10.62	1.00 H	312	66.38	28.9	4.70	-36.6	-3.00
2	2483.50	43.53	AV	54.00	10.47	1.00 H	312	46.53	28.9	4.70	-36.6	-3.00
3	4904.00	55.87	PK	74.00	18.13	1.00 H	258	52.07	33.0	7.00	36.2	3.80
3	4904.00	45.23	AV	54.00	8.77	1.00 H	258	41.43	33.0	7.00	36.2	3.80
4	7356.00	58.11	PK	74.00	15.89	1.00 H	12	48.71	36.2	8.50	35.3	9.40
4	7356.00	47.36	AV	54.00	6.64	1.00 H	12	37.96	36.2	8.50	35.3	9.40
5	9808.00	60.25	PK	74.00	13.75	1.00 H	100	47.65	37.3	10.10	34.8	12.60
5	9808.00	50.00	AV	54.00	4.00	1.00 H	100	37.40	37.3	10.10	34.8	12.60

ANTENNA POLARITY & TEST DISTANCE: VERTICAL AT 3 M

No.	Frequency (MHz)	Emission Level (dBuV/m)		Limit (dBuV/m)	Margin (dB)	Antenna Height (m)	Table Angle (Degree)	Raw Value (dBuV)	Antenna Factor (dB/m)	Cable Factor (dB)	Pre-amplifier (dB)	Correction Factor (dB/m)
1	*2452.00	102.05	PK			1.00 V	125	105.05	28.9	4.70	-36.6	-3.00
1	*2452.00	86.03	AV			1.00 V	125	89.03	28.9	4.70	-36.6	-3.00
2	2483.50	68.26	PK	74.00	5.74	1.00 V	300	71.26	28.9	4.70	-36.6	-3.00
2	2483.50	50.94	AV	54.00	3.06	1.00 V	300	53.94	28.9	4.70	-36.6	-3.00
3	4904.00	56.01	PK	74.00	17.99	1.00 V	346	52.21	33.0	7.00	36.2	3.80
3	4904.00	46.98	AV	54.00	7.02	1.00 V	346	43.18	33.0	7.00	36.2	3.80
4	7356.00	57.82	PK	74.00	16.18	1.00 V	157	48.42	36.2	8.50	35.3	9.40
4	7356.00	47.96	AV	54.00	6.04	1.00 V	157	38.56	36.2	8.50	35.3	9.40
5	9808.00	60.39	PK	74.00	13.61	1.00 V	287	47.79	37.3	10.10	34.8	12.60
5	9808.00	49.28	AV	54.00	4.72	1.00 V	287	36.68	37.3	10.10	34.8	12.60

- REMARKS:**
1. Emission level (dBuV/m) = Raw Value (dBuV) + Correction Factor (dB/m)
 2. Correction Factor (dB/m) = Antenna Factor (dB/m) + Cable Factor (dB) - Pre-amplifier Factor
 3. The other emission levels were very low against the limit.
 4. Margin value = Limit value - Emission level.
 5. The limit value is defined as per 15.247
 6. " * " : Fundamental frequency

Note:

The field strength is calculated by adding the Antenna Factor, Cable Factor & Pre-amplifier. The basic equation with a sample calculation is as follows:

Final Test Level = Receiver Reading + Antenna Factor + Cable Factor - Pre-amplifier Factor.

Remark: No any other emissions level which are attenuated less than 20dB below the limit

According to 15.31(o), The amplitude of spurious emissions from intentional radiators and emissions from unintentional radiators which are attenuated more than 20 dB below the permissible value need not be reported unless specifically required elsewhere in this Part.

Hence there no other emissions have been reported.

According to 15.31(o), The amplitude of spurious emissions from intentional radiators and emissions from unintentional radiators which are attenuated more than 20 dB below the permissible value need not be reported unless specifically required elsewhere in this Part.

Hence there no other emissions have been reported.

Remark:

- 1). As shown in Section, for frequencies above 1000 MHz. the above field strength limits are based on average limits. However, the peak field strength of any emission shall not exceed the maximum permitted average limits specified above by more than 20 dB under any condition of modulation.
- 2). The test only perform the EUT in transmitting status since the test frequencies were over 1GHz only required transmitting status.
- 3) Pre-Scan has been conducted to determine the worst-case mode from all possible Combinations between available modulations, data rates and antenna ports, and found the EUT worse case mode: 802.11b (11MHz), 802.11g (54MHz)
- 4) For this intentional radiator operates below 25 GHz. The spectrum shall be investigated to the tenth harmonic of the highest fundamental frequency. And above the 4th harmonic of this intentional radiator, the disturbance is very low. So the test result only displays to 4th harmonic.



4.3. 6dB Bandwidth Measurement

TEST CONFIGURATION

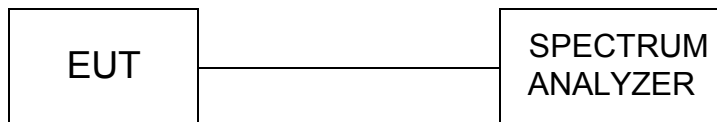

TEST PROCEDURE

1. The testing follows FCC KDB Publication No. 558074 D01 v03r02 (Measurement Guidelines of DTS).
2. The RF output of EUT was connected to the spectrum analyzer by a low loss cable.
3. Make the measurement with the spectrum analyzer's resolution bandwidth (RBW) = 100 kHz. In order to make an accurate measurement, set the span greater than RBW. The 6 dB bandwidth must be greater than 500 kHz.
4. The marker-delta reading at this point is the 6 dB bandwidth of the emission.

LIMIT

For digital modulation systems, the minimum 6 dB bandwidth shall be at least 500 kHz.

TEST RESULTS

Mode	CHANNEL	6dB BANDWIDTH (MHz)		MINIMUM LIMIT (MHz)	PASS/FAIL
		Ant 1 6dB	Ant 2 6dB		
802.11b	1	7.712	7.104	0.5	PASS
	6	7.734	8.236	0.5	PASS
	11	7.740	8.188	0.5	PASS
802.11g	1	16.560	15.314	0.5	PASS
	6	16.513	15.489	0.5	PASS
	11	16.577	15.399	0.5	PASS
802.11n HT20	1	17.740	17.292	0.5	PASS
	6	17.757	16.689	0.5	PASS
	11	17.725	16.677	0.5	PASS
802.11n HT40	3	35.810	35.745	0.5	PASS
	6	35.638	35.417	0.5	PASS
	9	36.045	35.451	0.5	PASS

For 802.11b:

CH1 @ANT 1

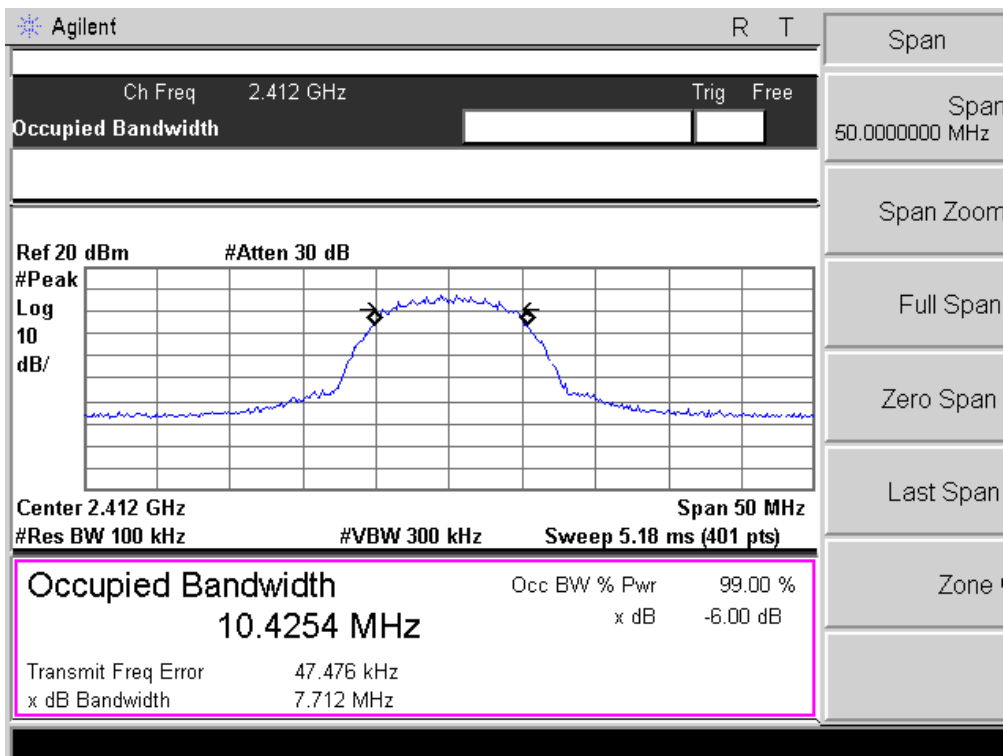

CH1 @ANT 2

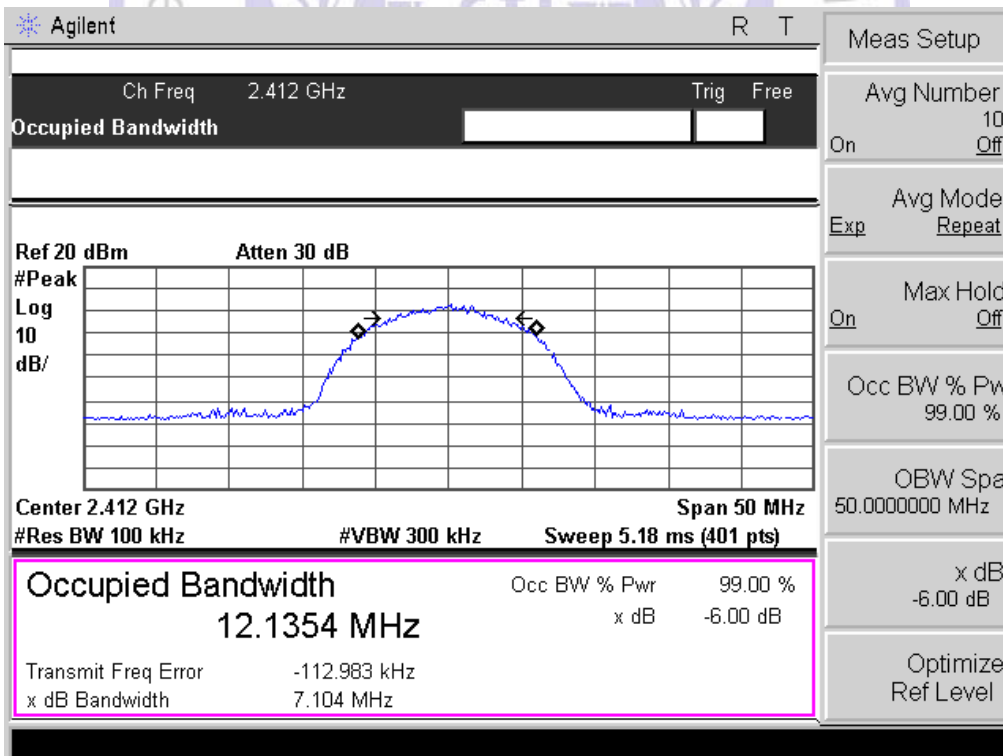

CH6 @ANT 1

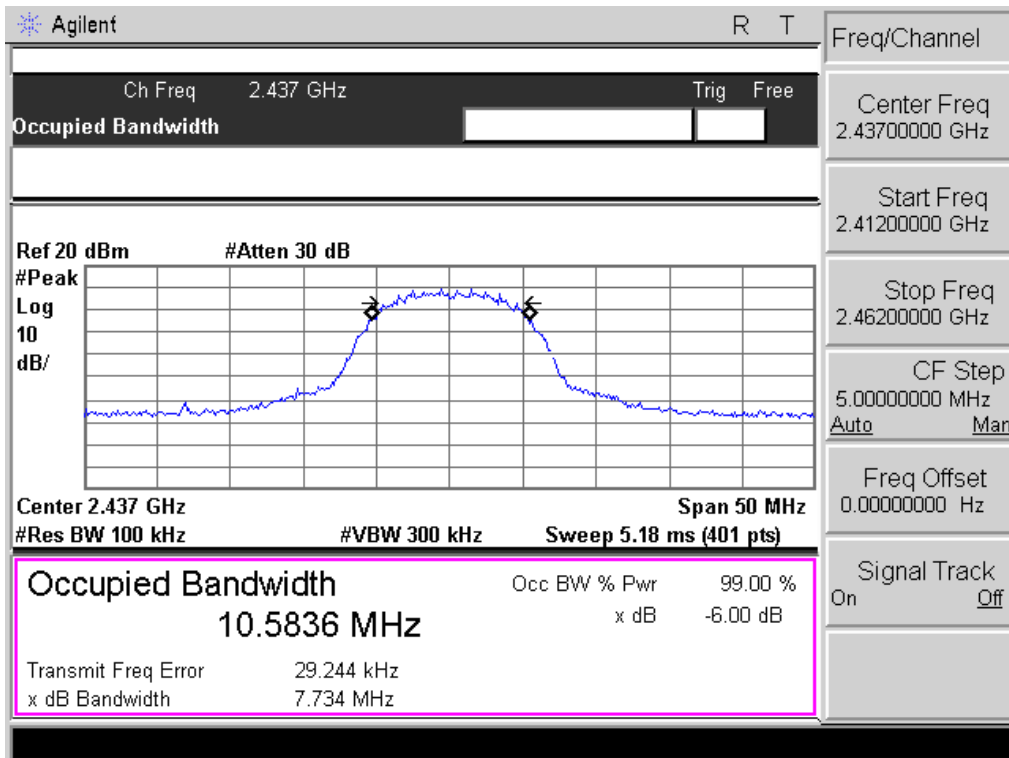

CH6 @ANT 2

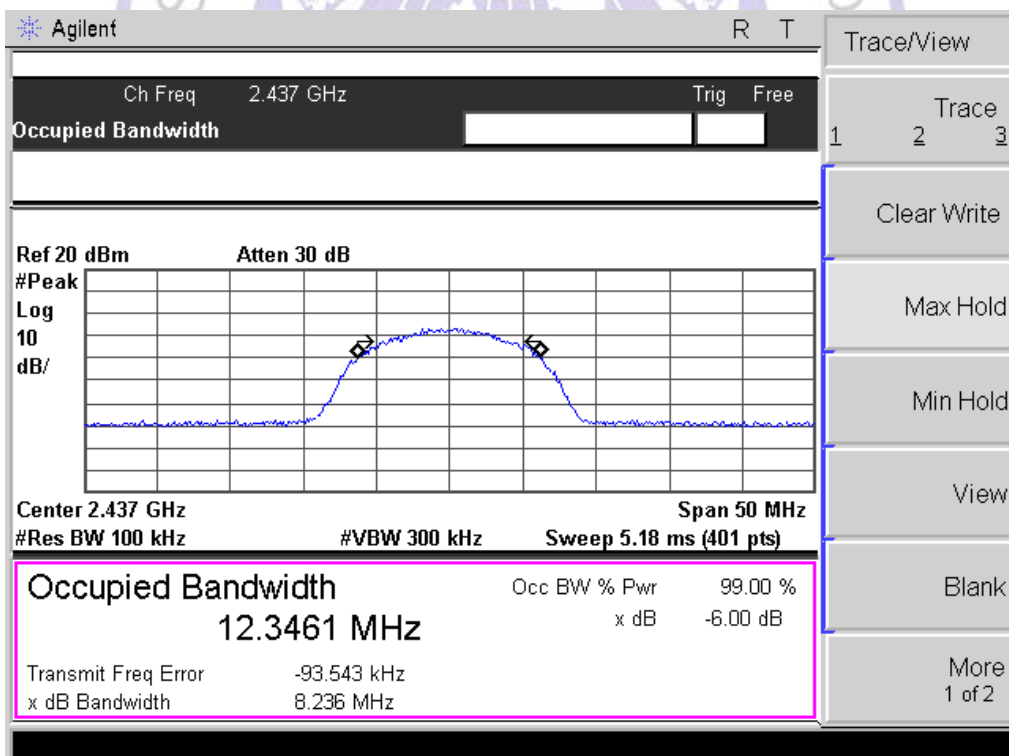

CH11 @ANT 1

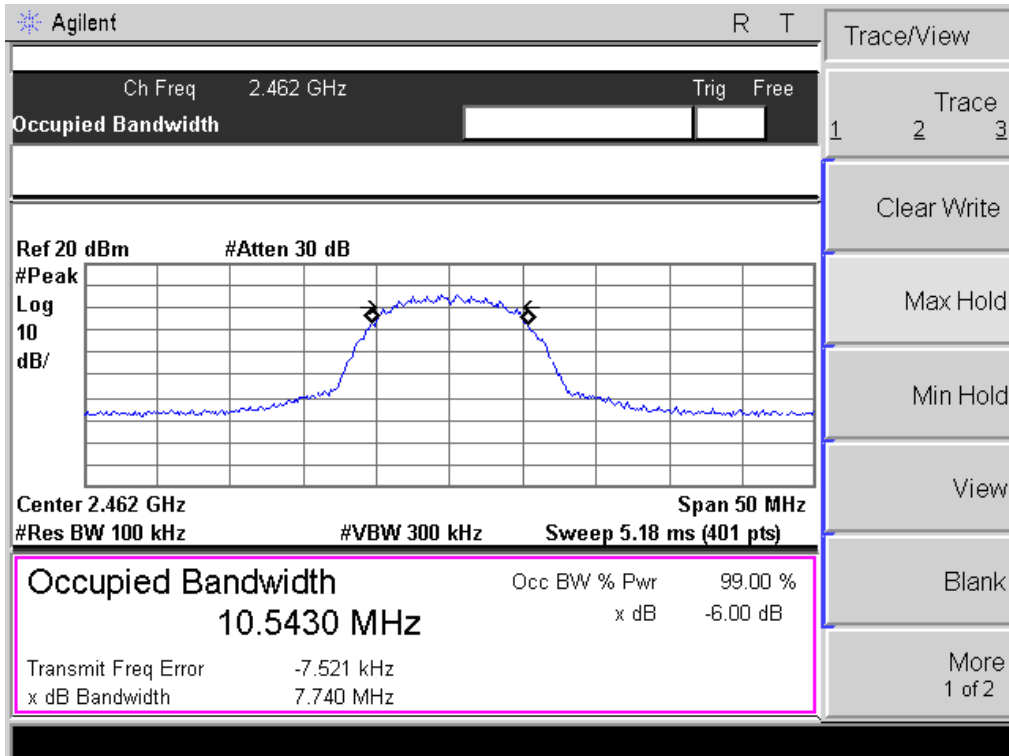

CH11 @ANT 2

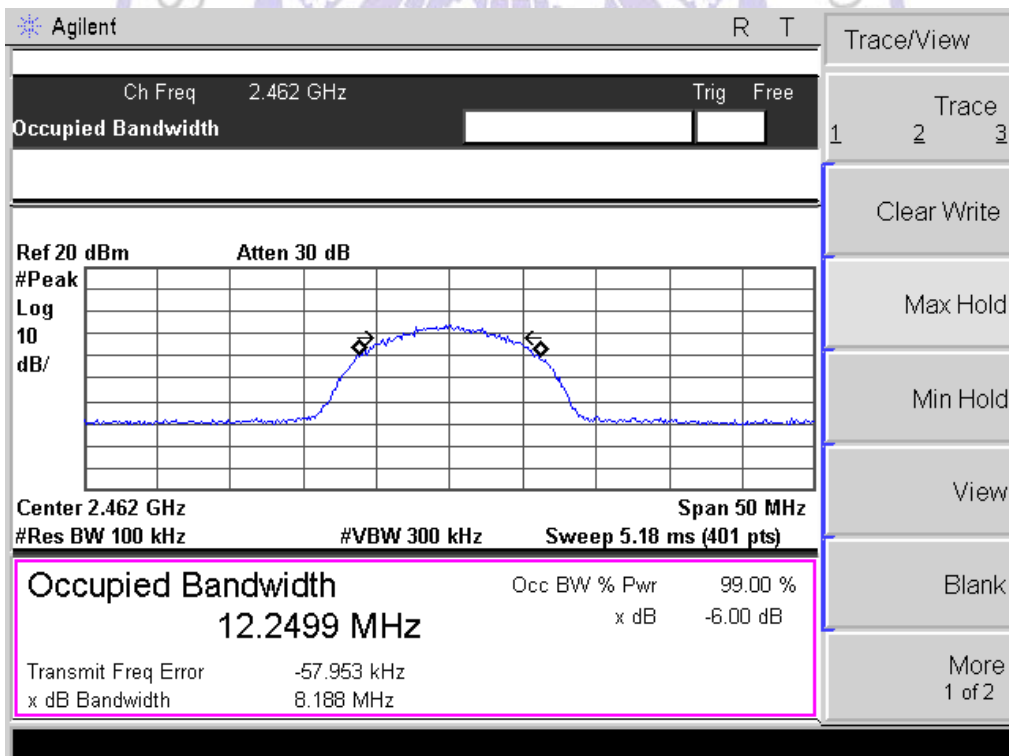

For 802.11g:

CH1 @ANT 1

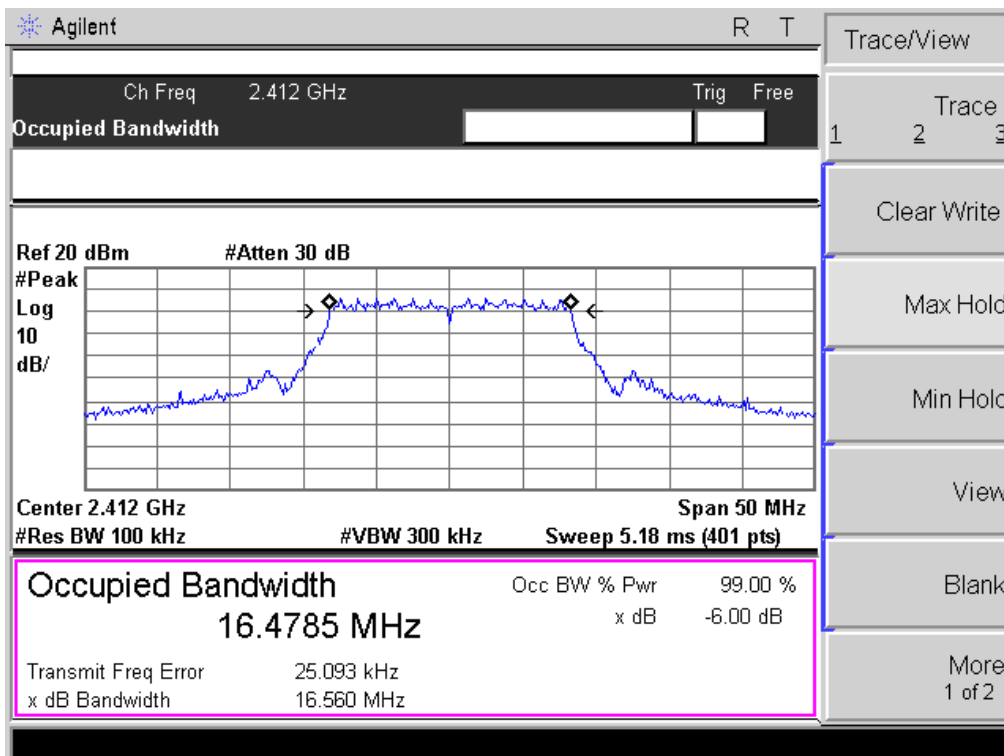

CH1 @ANT 2

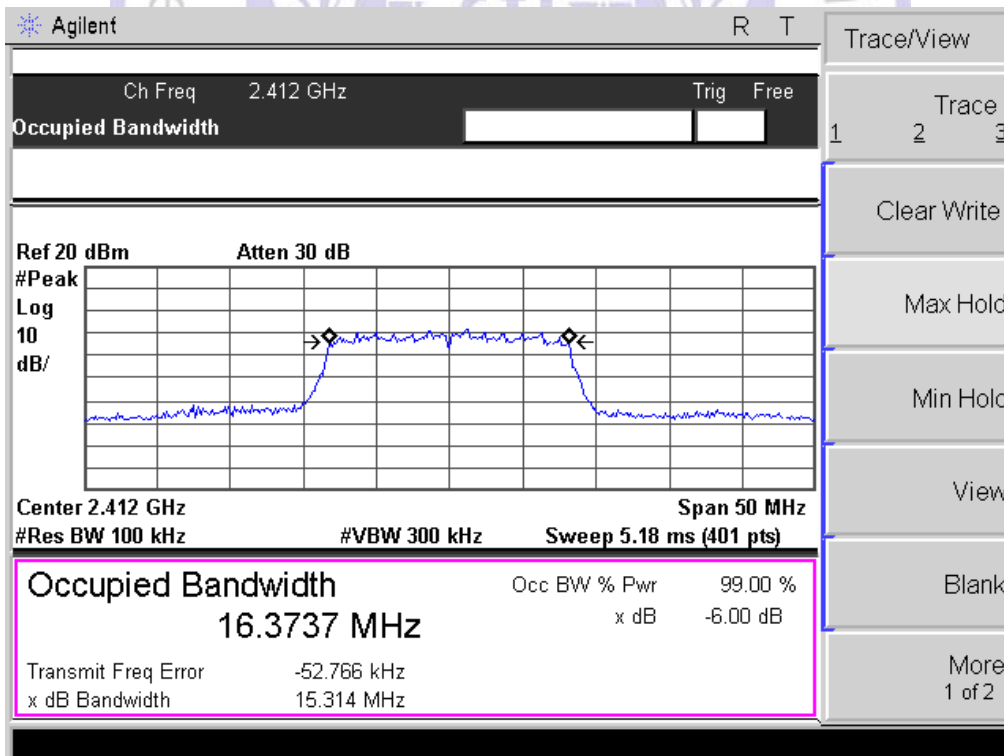

CH6 @ ANT 1

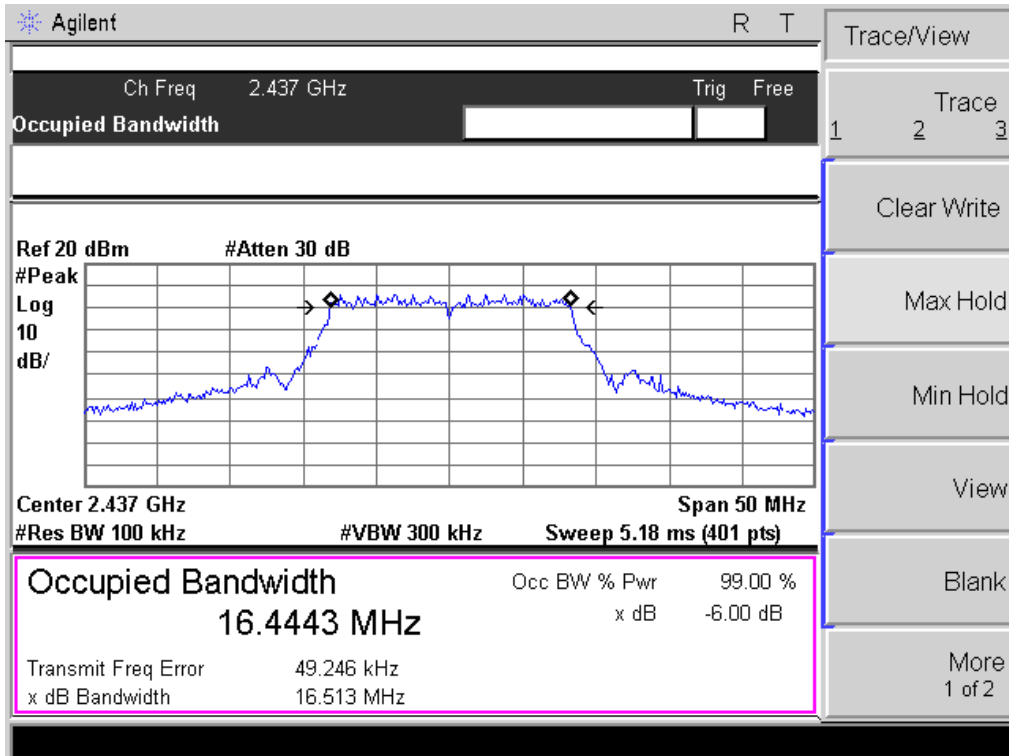

CH6 @ANT 2

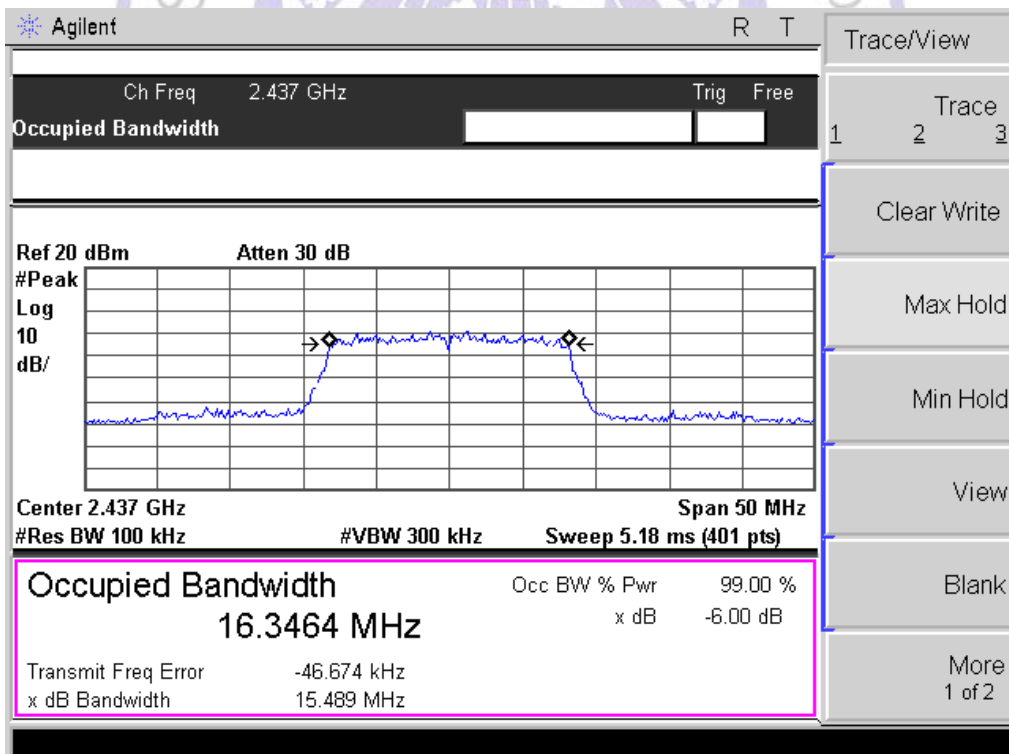

CH11 @ANT 1

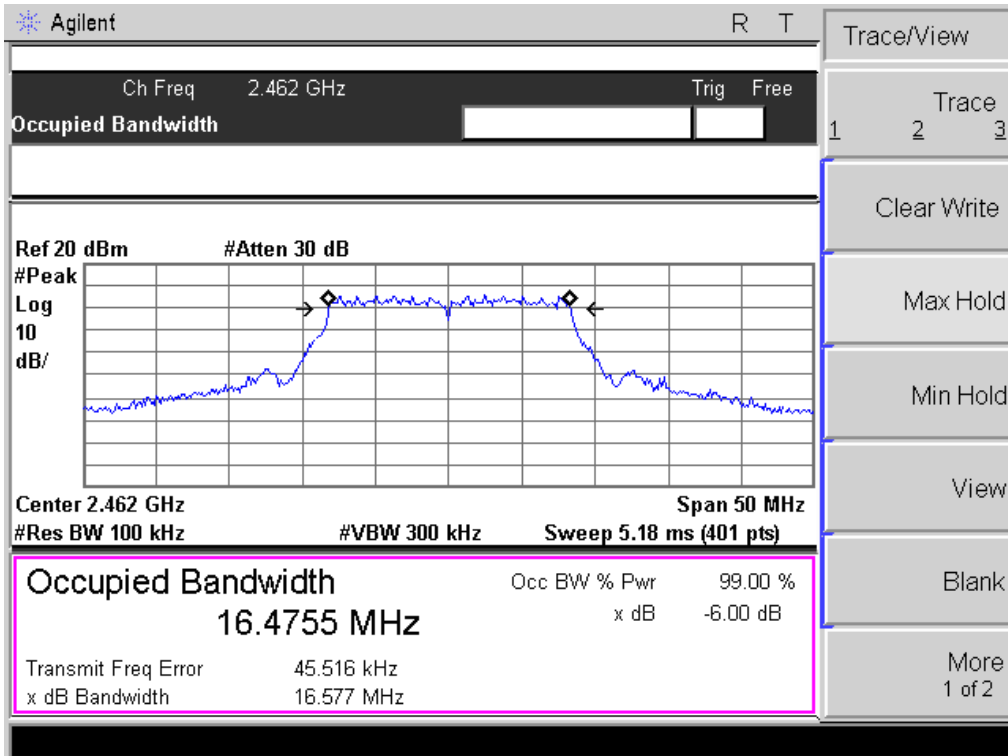

CH11 @ANT 2

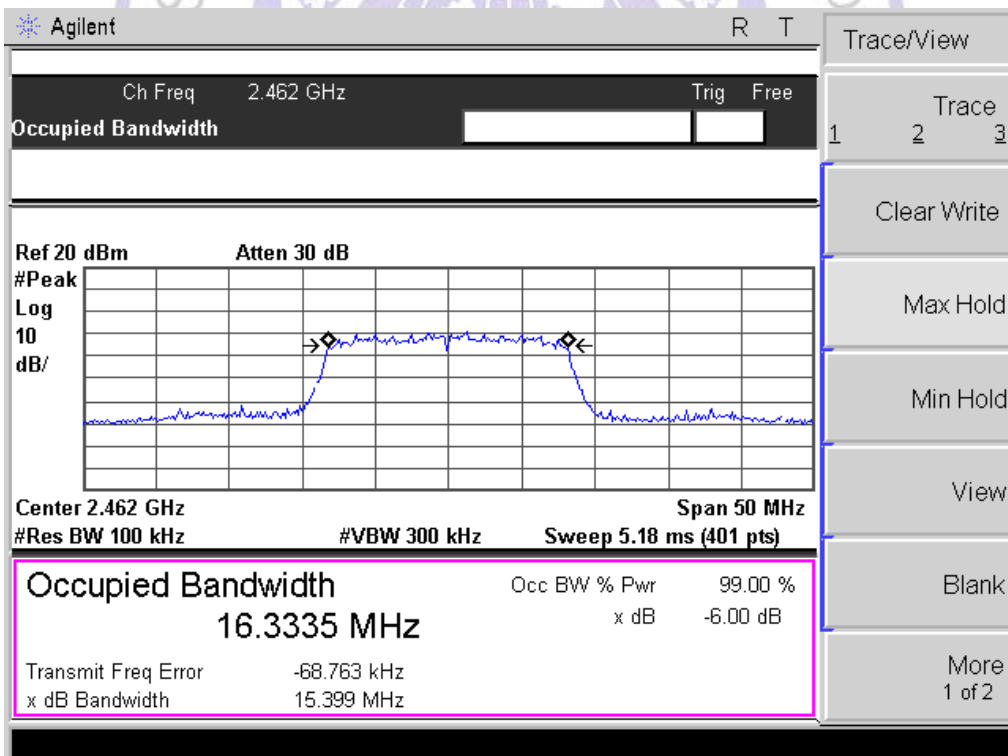

For 802.11n (20MHz) Mode:

CH1 @ANT 1

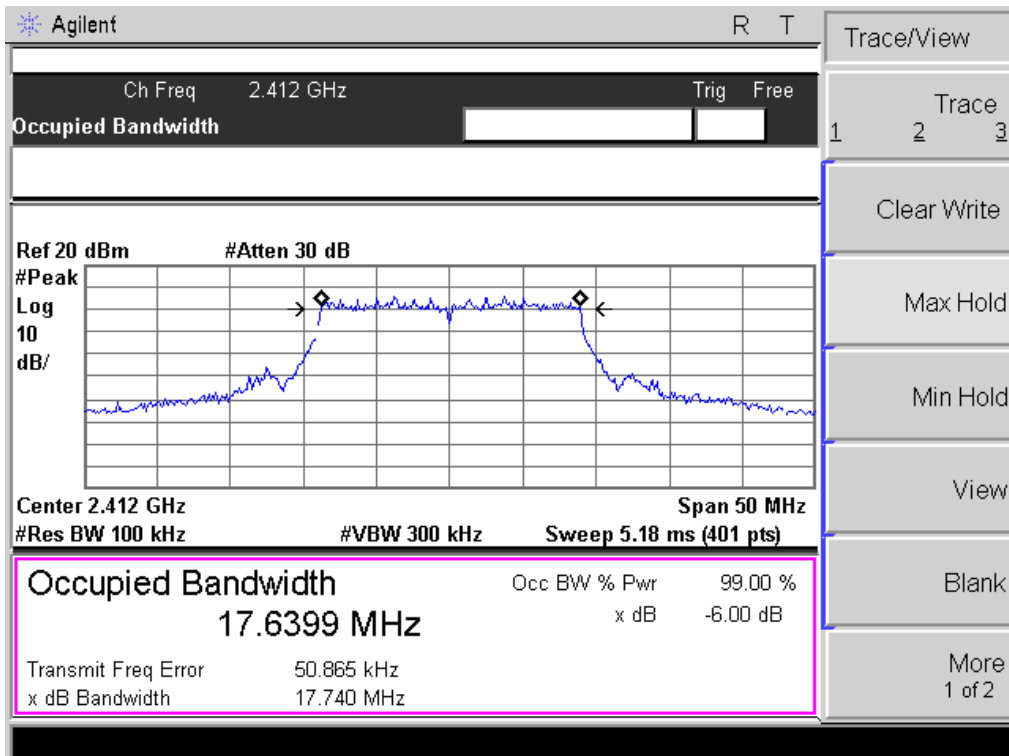

CH1 @ANT 2

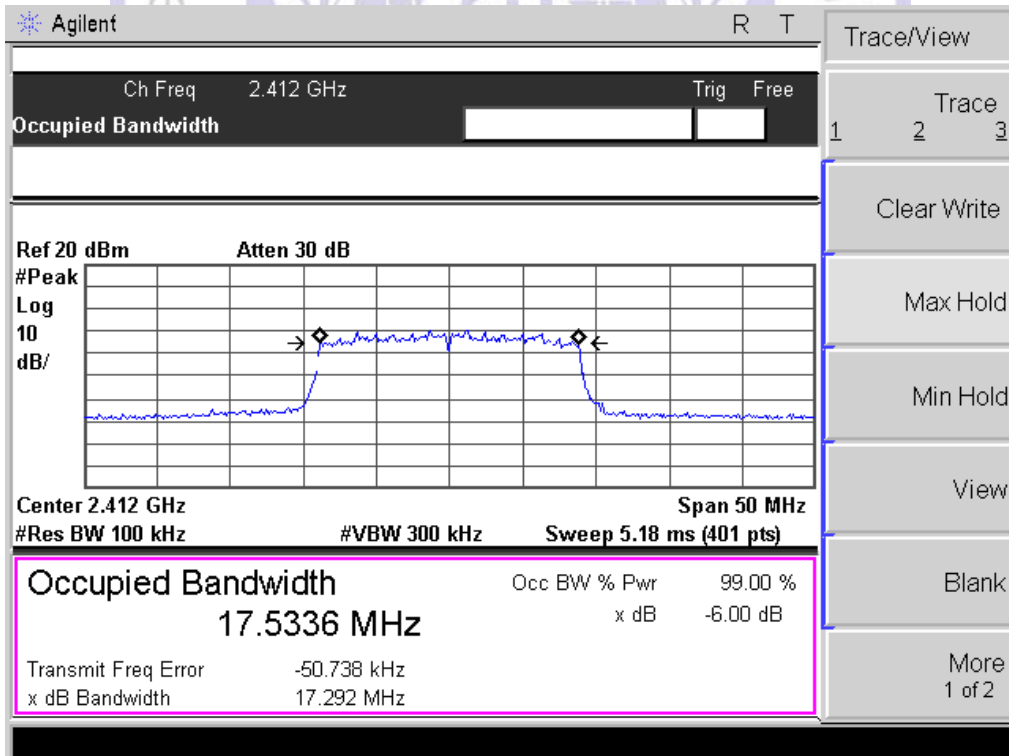

CH6 @ANT 1

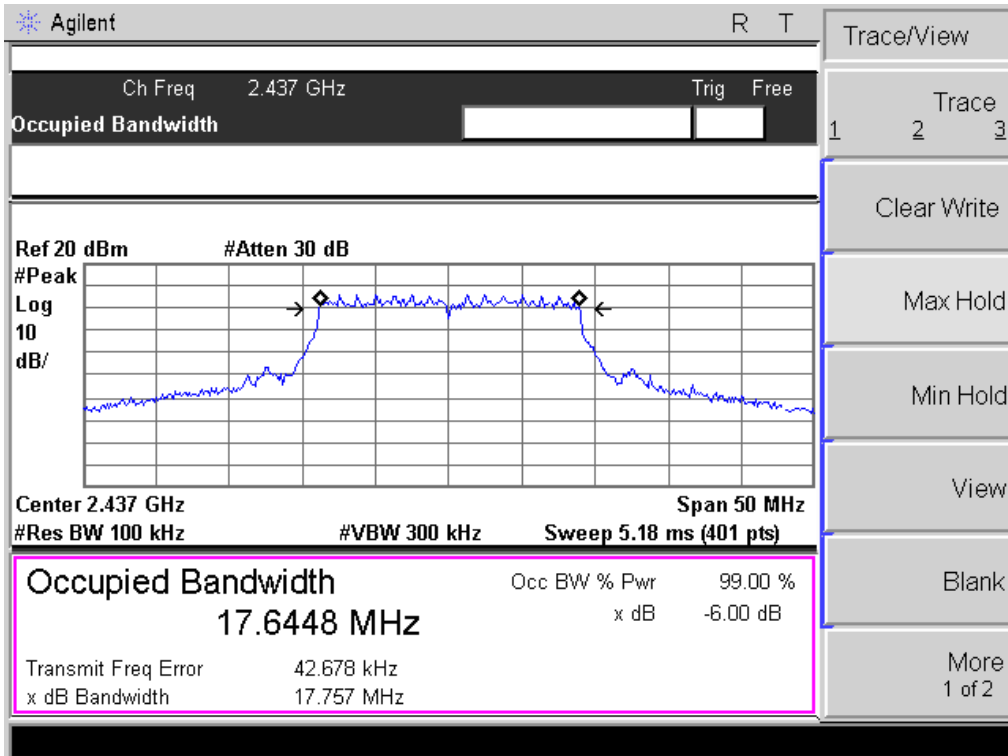

CH6 @ANT 2

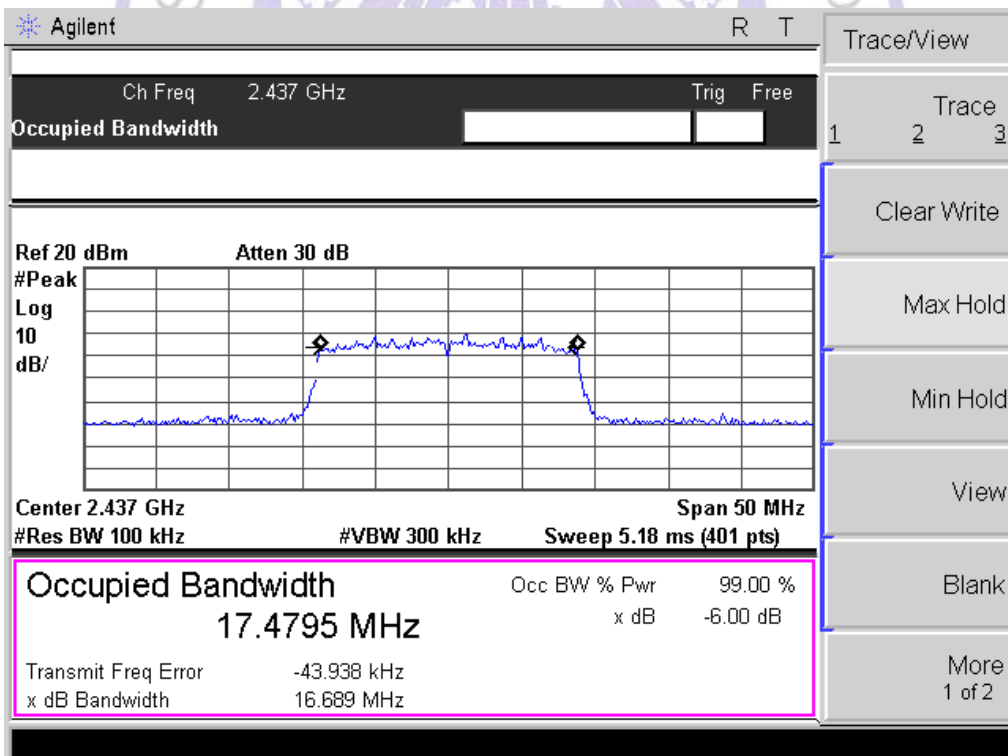

CH11 @ANT 1

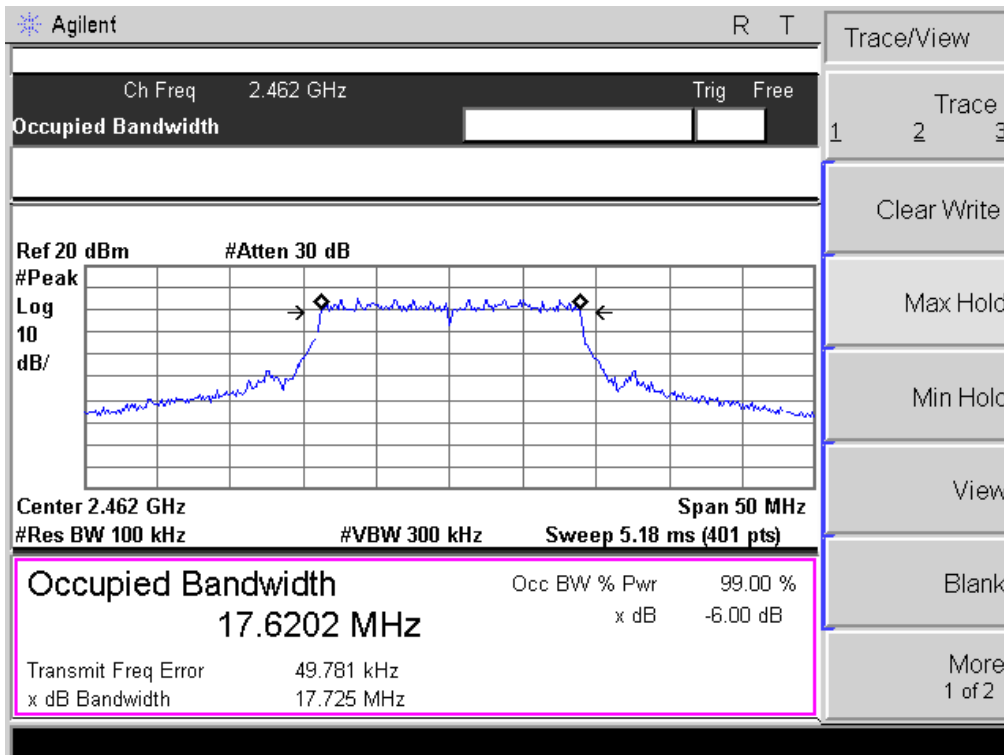

CH11 @ANT 2

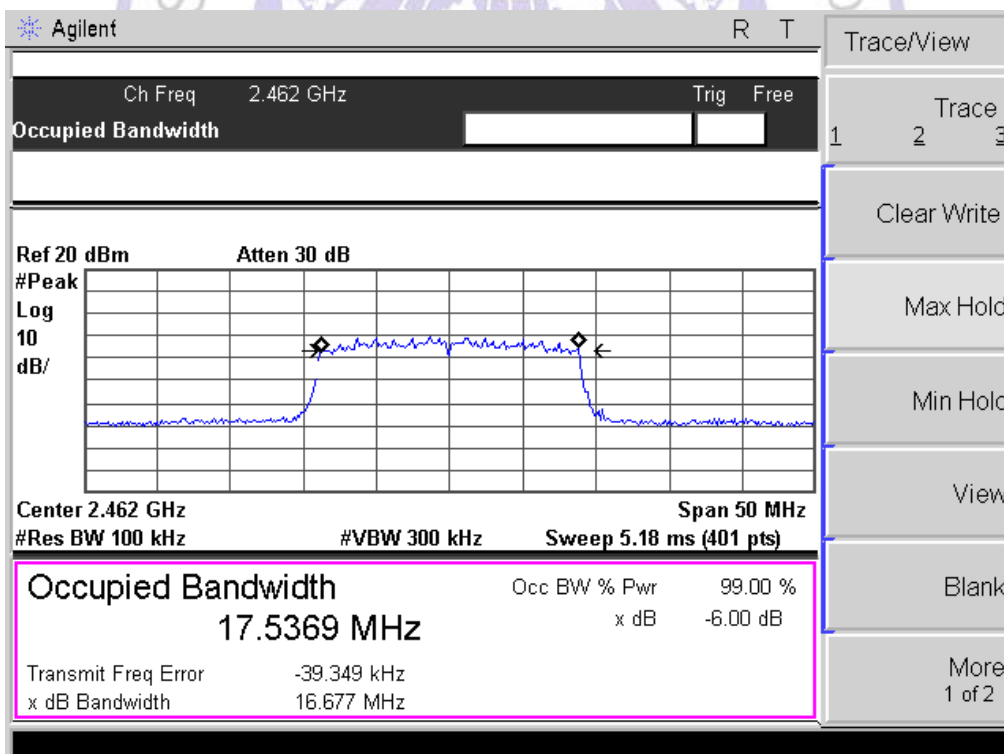

For 802.11n (40MHz) Mode:

CH3 @ANT 1

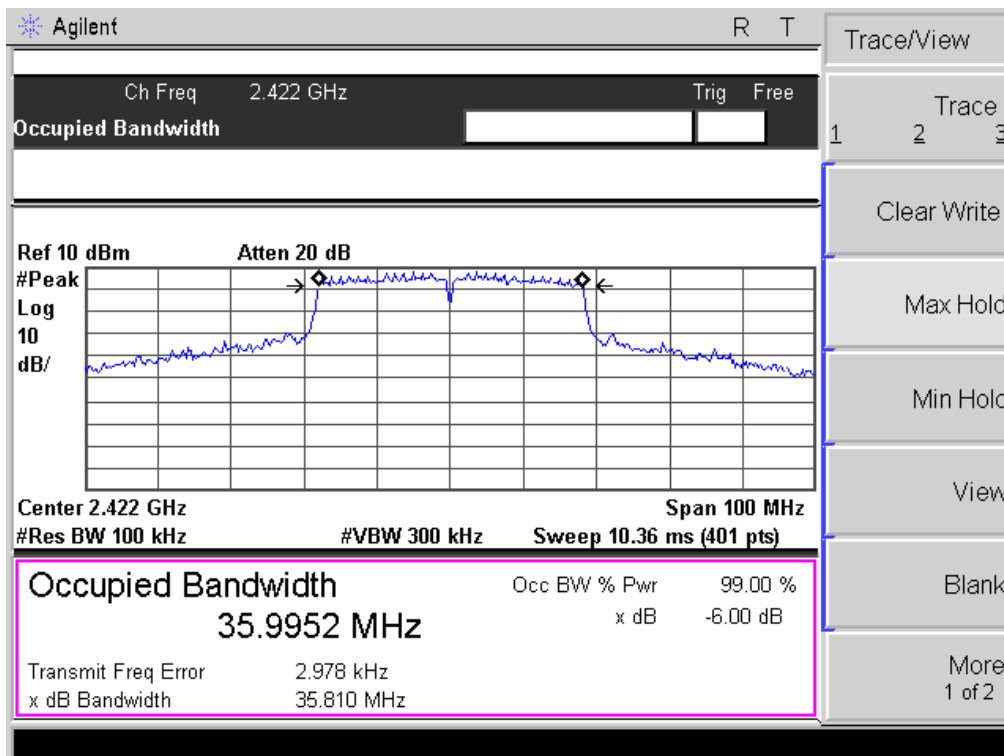

CH3 @ANT 2

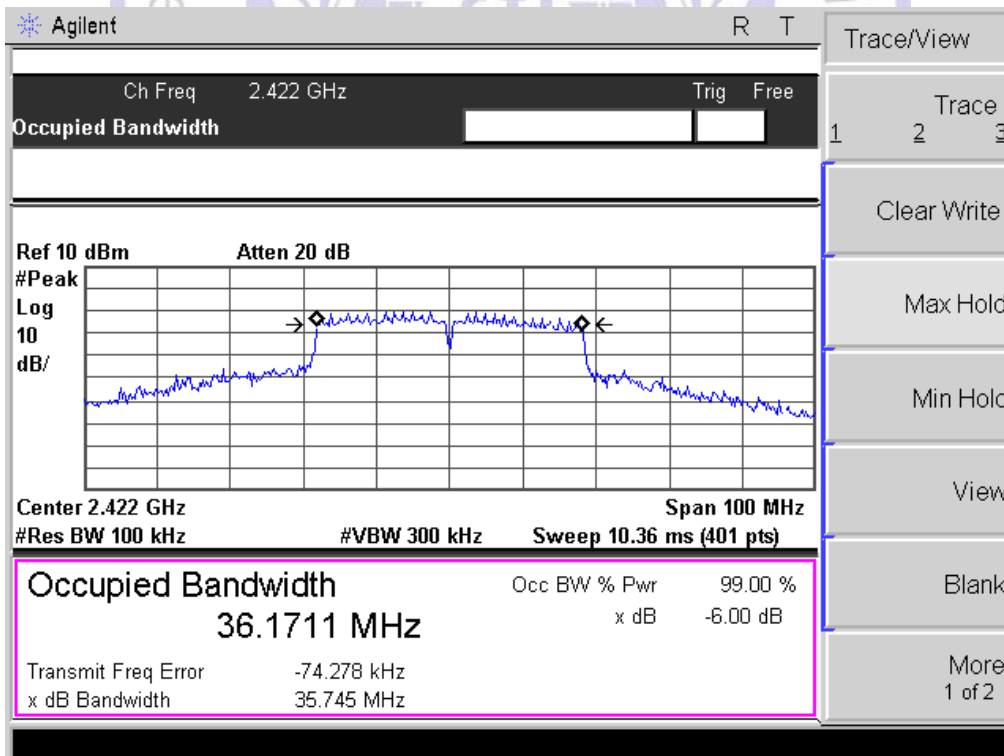

CH6 @ANT 1

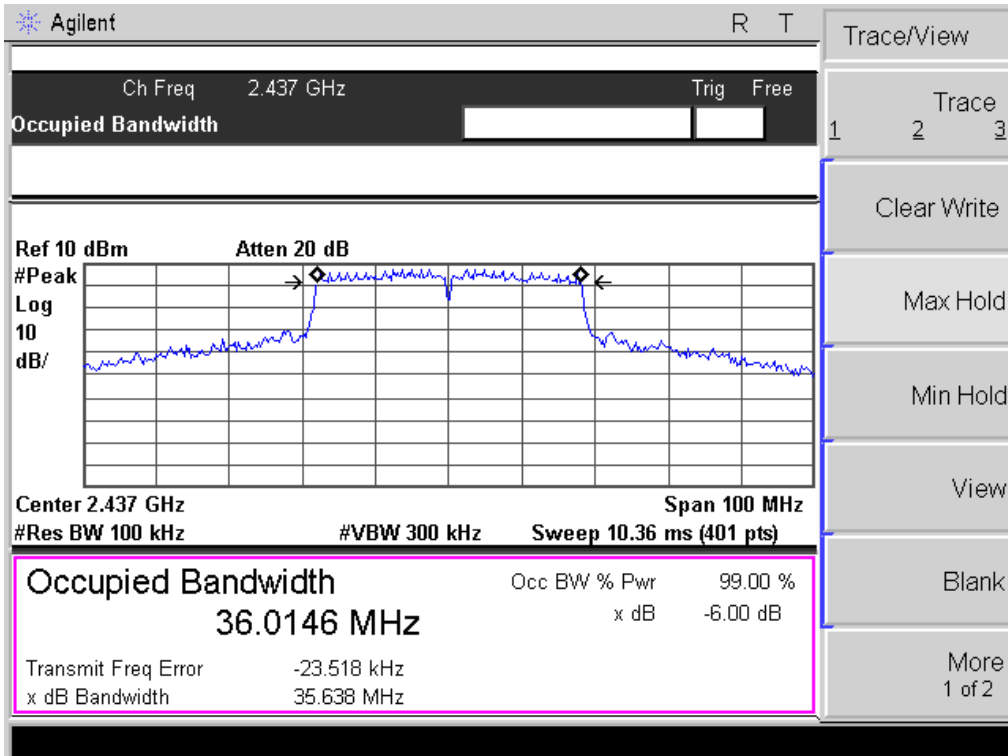

CH6 @ANT 2

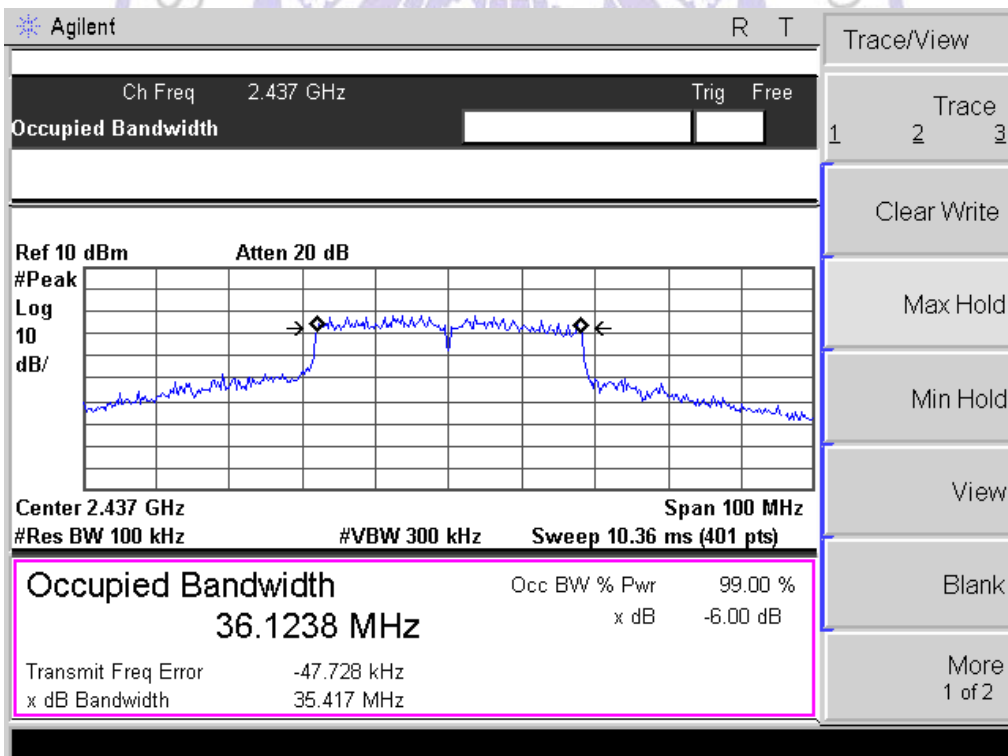

CH9 @ANT 1

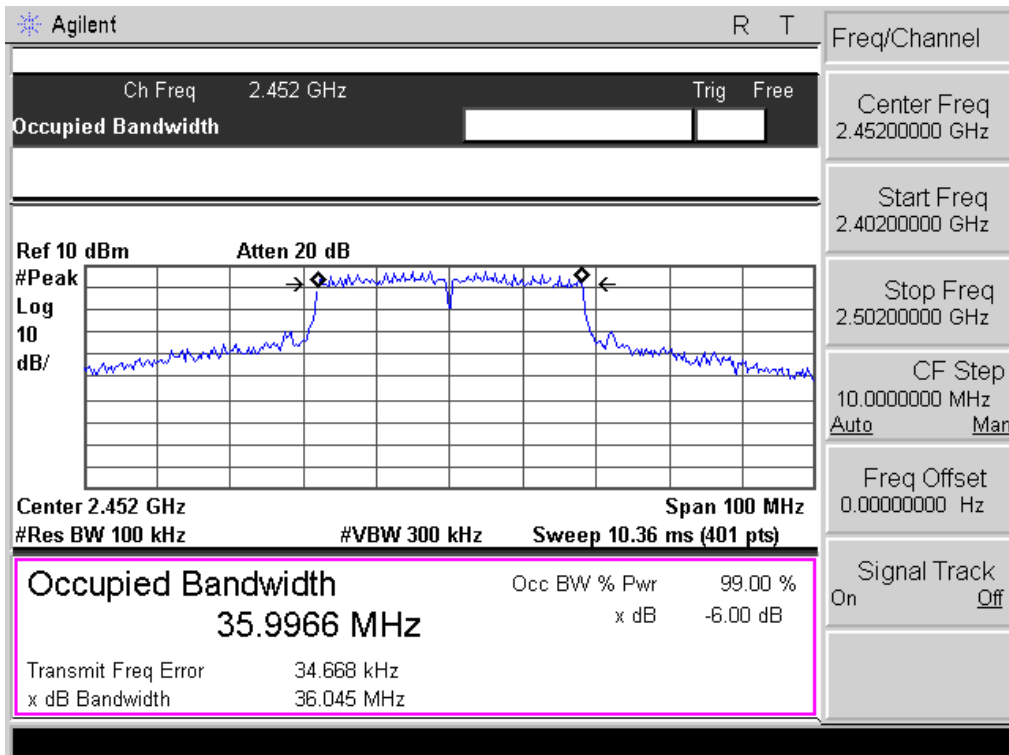

CH9 @ANT 2

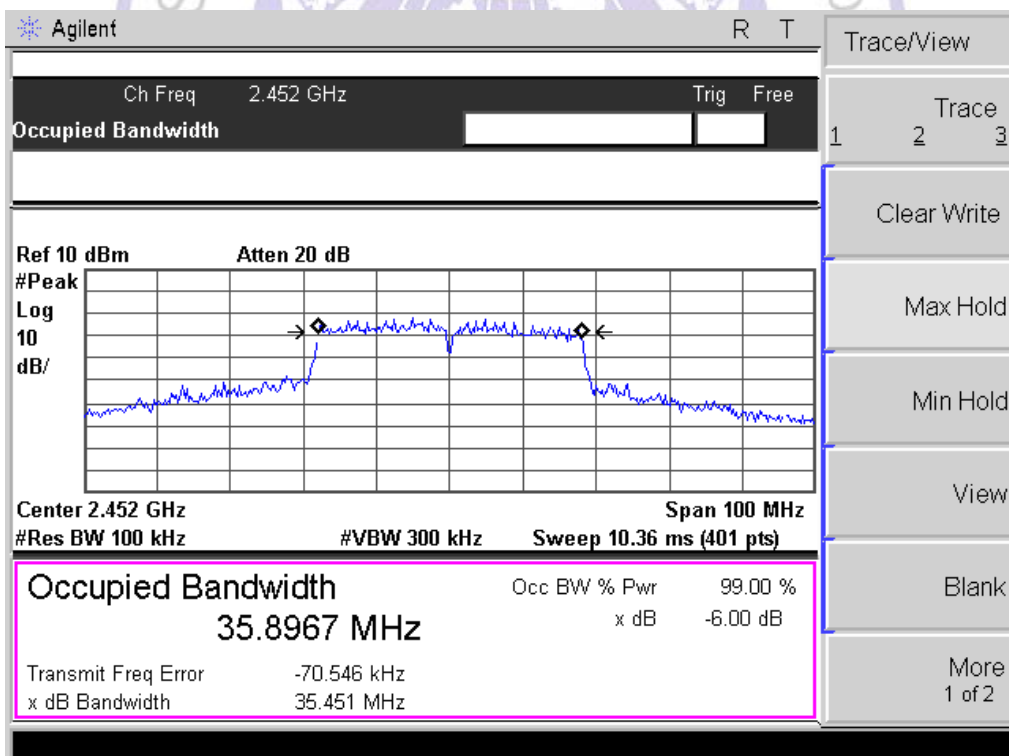

4.4. Maximum Peak Output Power

TEST CONFIGURATION

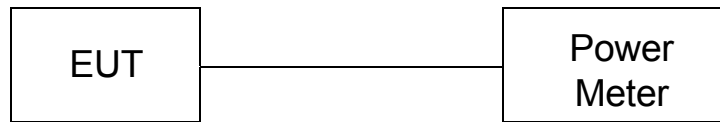

TEST PROCEDURE

According to C63.10 -2009 and KDB558074 D01 v03r02, The EUT was directly connected to the power meter / spectrum analyzer and antenna output port as show in the block diagram as TEST CONFIGURATION shows.

Use the wideband power meter to test peak power and record the result.

LIMIT

The Peak Output Power Measurement limits are 30dBm.

TEST RESULTS

Mode	Channel	Peak Power Output (dBm)			Peak Power Limit (dBm)	PASS / FAIL
		Ant1	Ant 2	Total		
802.11b	1	15.72	15.67	N/A	30	PASS
	6	15.39	15.77	N/A	30	PASS
	11	15.55	15.14	N/A	30	PASS
802.11g	1	14.90	14.13	N/A	30	PASS
	6	14.27	14.80	N/A	30	PASS
	11	14.75	14.37	N/A	30	PASS
802.11n HT20	1	14.64	14.95	17.81	30	PASS
	6	14.14	14.24	17.20	30	PASS
	11	14.24	14.25	17.26	30	PASS
802.11n HT40	3	14.24	14.46	17.36	30	PASS
	6	14.60	14.87	17.75	30	PASS
	9	14.14	14.32	17.24	30	PASS

Note: The test results including the cable lose.

4.5. Band Edge Measurement

TEST CONFIGURATION

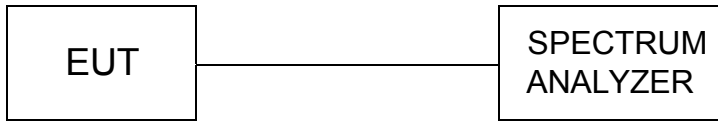

TEST PROCEDURE

The band edge compliance of RF radiated emission should be measured by following the guidance in ANSI C63.10 and FCC KDB Publication No. 558074 D01 v03r02 (Measurement Guidelines of DTS) with respect to maximizing the emission by rotating the EUT, measuring the emission while the EUT is situated in three orthogonal planes (if appropriate), adjusting the measurement antenna height and polarization etc. Set RBW=100kHz and VBM= 300KHz to measure the peak field strength and set RBW to 1MHz and VBW to 10Hz to measure the average radiated field strength.

The conducted RF band edge was measured by using a spectrum analyzer. Set span wide enough to capture the highest in-band emission and the emission at the band edge. Set RBW to 100kHz and VBW to 300 kHz, to measure the conducted peak band edge.

Connect the spectrum analyzer to the EUT using an appropriate RF cable connected to the EUT output. Configure the spectrum analyzer settings as described below (be sure to enter all losses between the unlicensed wireless device output and the spectrum analyzer).

- Span: Set Span for minimum 50 MHz - Reference Level: 110 dB μ V (corrected for gains and losses of test antenna factor, preamp gain and cable loss) - Attenuation: 10 dB
- Sweep Time: Coupled - Resolution Bandwidth: Up to and including 1 GHz = \geq 100 kHz
- Resolution Bandwidth: Above 1 GHz = 1 MHz - Video Bandwidth: Below 1 GHz = 300 kHz
- Video Bandwidth: Up to and including 1 GHz = \geq 3 MHz for peak and 10 Hz for average
- Detector: Peak

Place a marker at the end of the restricted band closest to the transmit frequency to show compliance. Also measure any emissions in the restricted bands. Save the spectrum analyzer plot. Repeat for each power and modulation for lowest and highest channel.

LIMIT

1. Below -20dB of the highest emission level in operating band.
2. Fall in the restricted bands listed in section 15.205. The maximum permitted average field strength is listed in section 15.209(see Section 15.205(c)).

Frequency (MHz)	Limit Average (dB μ v/m)	Limit Peak (dB μ v/m)
Below 2390 or Above 2483.5	54	74

TEST RESULTS

Transmitting mode: 802.11b

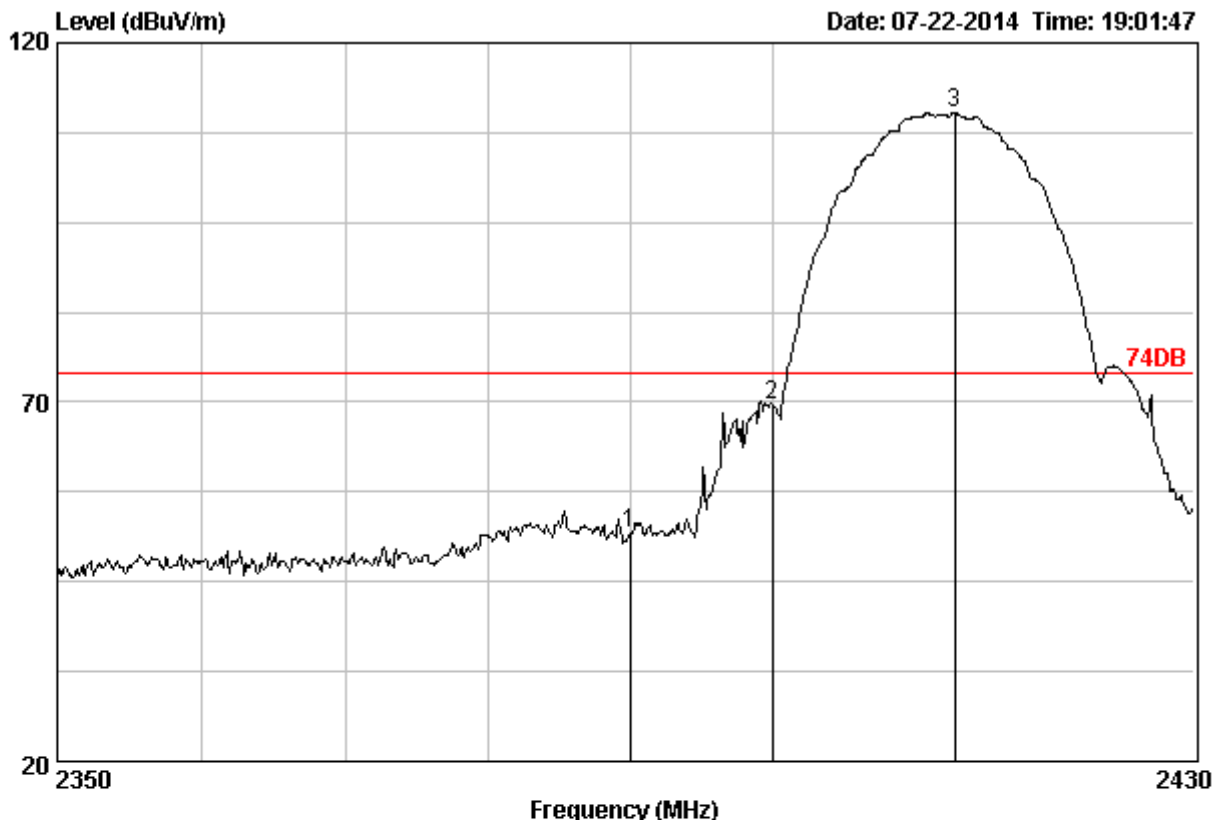

```

Site no.       : 3m Chamber           Data no. : 292
Dis. / Ant.   : 3m DRH-118          Ant. pol. : VERTICAL
Limit         : 74DB
Env. / Ins.   : 23*C/54%
Engineer      :
EUT           : 802.11b/g/n wireless router
Power         :
M/N           :
Test Mode     :
    
```

	Freq. (MHz)	Ant. Factor (dB)	Cable Loss (dB)	Reading (dBuV)	Emission		Margin (dB)	Remark
					Level (dBuV/m)	Limits (dBuV/m)		
1	2390.00	28.78	4.61	53.63	51.66	74.00	22.34	Peak
2	2400.00	28.78	4.61	71.58	69.61	74.00	4.39	Peak
3	2412.96	28.81	4.63	112.17	110.25	74.00	-36.25	Peak

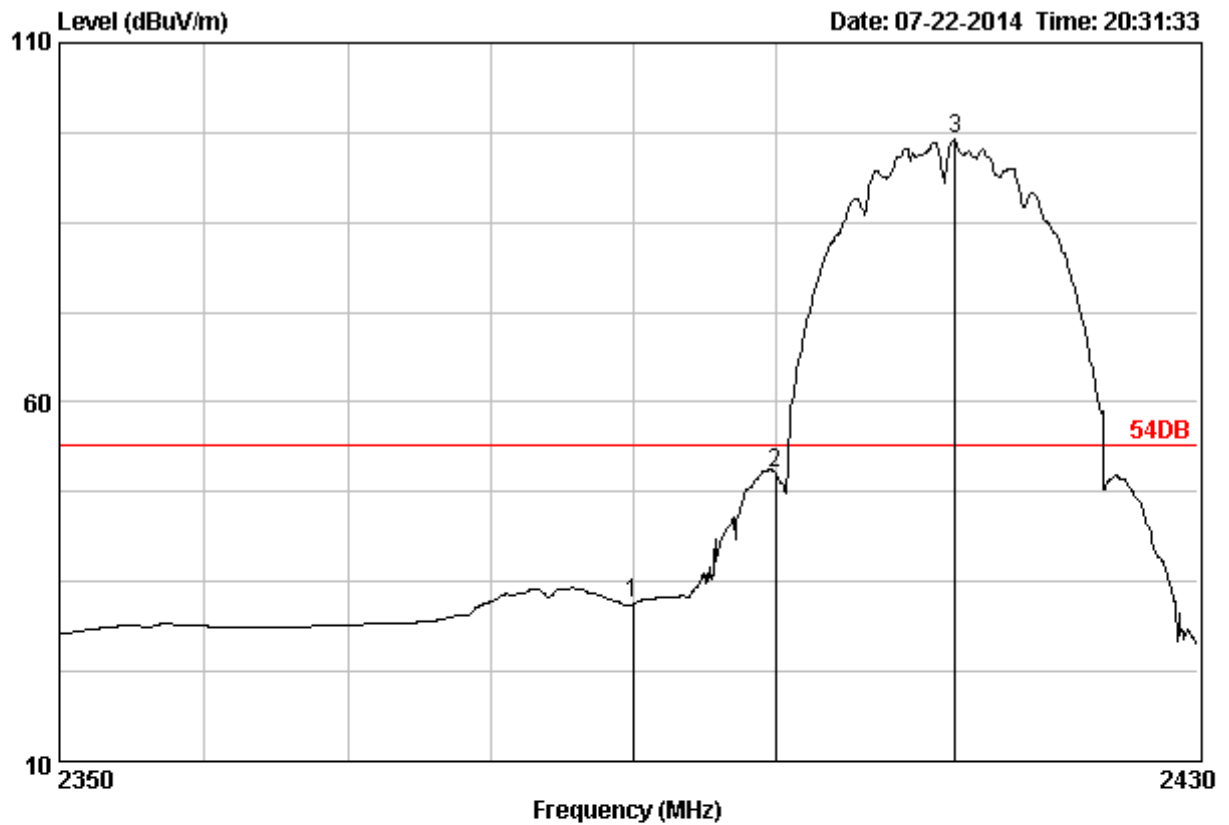

Site no. : 3m Chamber
 Dis. / Ant. : 3m DRH-118
 Limit : 54DB
 Env. / Ins. : 23*C/54%
 Engineer :
 EUT : 802.11b/g/n wireless router
 Power :
 M/N :
 Test Mode :

Data no. : 311
 Ant. pol. : VERTICAL

	Freq. (MHz)	Ant. Factor (dB)	Cable Loss (dB)	Reading (dBuV)	Emission			Remark
					Level (dBuV/m)	Limits (dBuV/m)	Margin (dB)	
1	2390.00	28.78	4.61	33.91	31.94	54.00	22.06	Average
2	2400.00	28.78	4.61	52.05	50.08	54.00	3.92	Average
3	2412.72	28.81	4.63	98.44	96.52	54.00	-42.52	Average

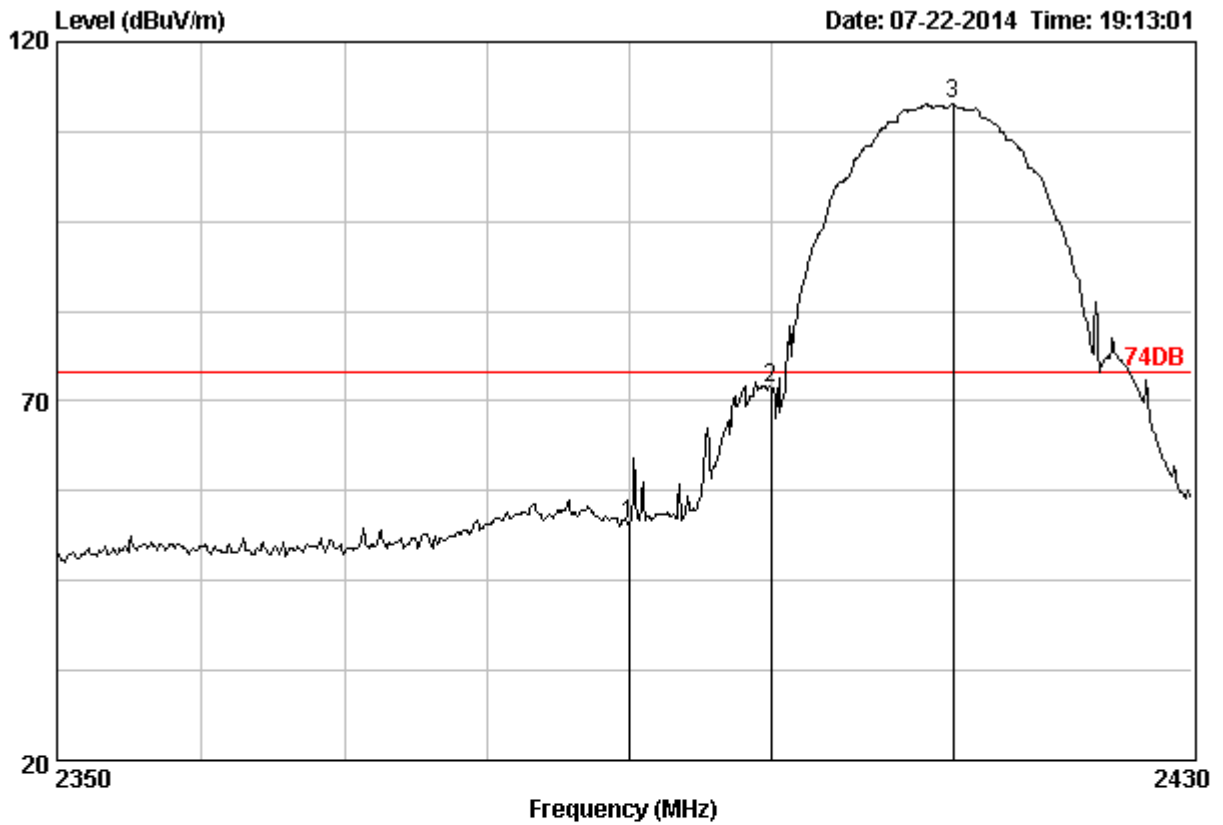

Site no. : 3m Chamber
 Dis. / Ant. : 3m DRH-118
 Limit : 74DB
 Env. / Ins. : 23*C/54%
 Engineer :
 EUT : 802.11b/g/n wireless router
 Power :
 M/N :
 Test Mode :

Data no. : 293
 Ant. pol. : HORIZONTAL

	Freq. (MHz)	Ant. Factor (dB)	Cable Loss (dB)	Emission				Remark
				Reading (dBuV)	Level (dBuV/m)	Limits (dBuV/m)	Margin (dB)	
1	2390.00	28.78	4.61	54.93	52.96	74.00	21.04	Peak
2	2400.00	28.78	4.61	73.87	71.90	74.00	2.10	Peak
3	2412.96	28.81	4.63	113.23	111.31	74.00	-37.31	Peak

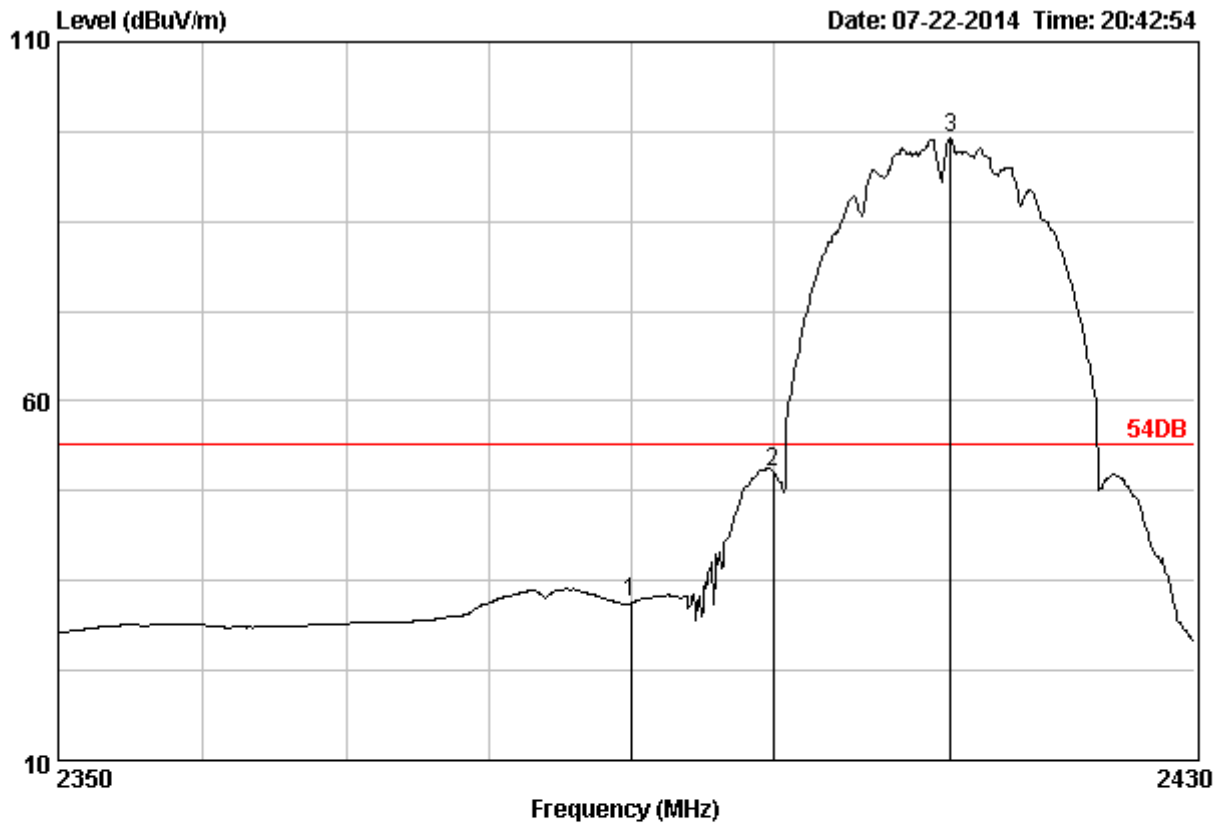

Site no. : 3m Chamber
 Dis. / Ant. : 3m DRH-118
 Limit : 54DB
 Env. / Ins. : 23°C/54%
 Engineer :
 EUT : 802.11b/g/n wireless router
 Power :
 M/N :
 Test Mode :

Data no. : 312
 Ant. pol. : HORIZONTAL

Freq. (MHz)	Ant. Factor (dB)	Cable Loss (dB)	Reading (dBuV)	Emission		Margin (dB)	Remark	
				Level (dBuV/m)	Limits (dBuV/m)			
1	2390.00	28.78	4.61	33.89	31.92	54.00	22.08	Average
2	2400.00	28.78	4.61	52.22	50.25	54.00	3.75	Average
3	2412.56	28.81	4.63	98.51	96.59	54.00	-42.59	Average

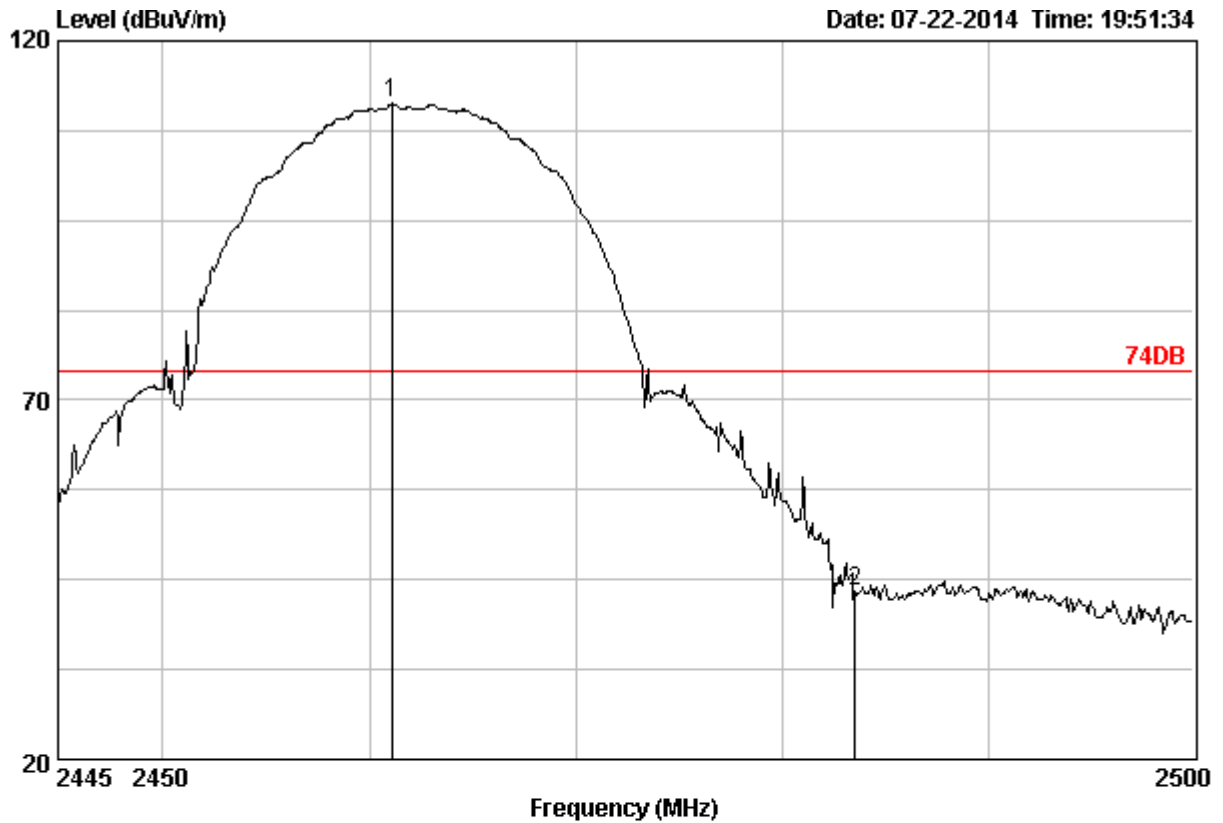

Site no. : 3m Chamber Data no. : 306
 Dis. / Ant. : 3m DRH-118 Ant. pol. : VERTICAL
 Limit : 74DB
 Env. / Ins. : 23*C/54%
 Engineer :
 EUT : 802.11b/g/n wireless router
 Power :
 M/N :
 Test Mode :

	Freq. (MHz)	Ant. Factor (dB)	Cable Loss (dB)	Emission				Remark
				Reading (dBuV)	Level (dBuV/m)	Limits (dBuV/m)	Margin (dB)	
1	2461.06	28.90	4.68	113.03	111.24	74.00	-37.24	Peak
2	2483.50	28.93	4.70	45.07	43.32	74.00	30.68	Peak

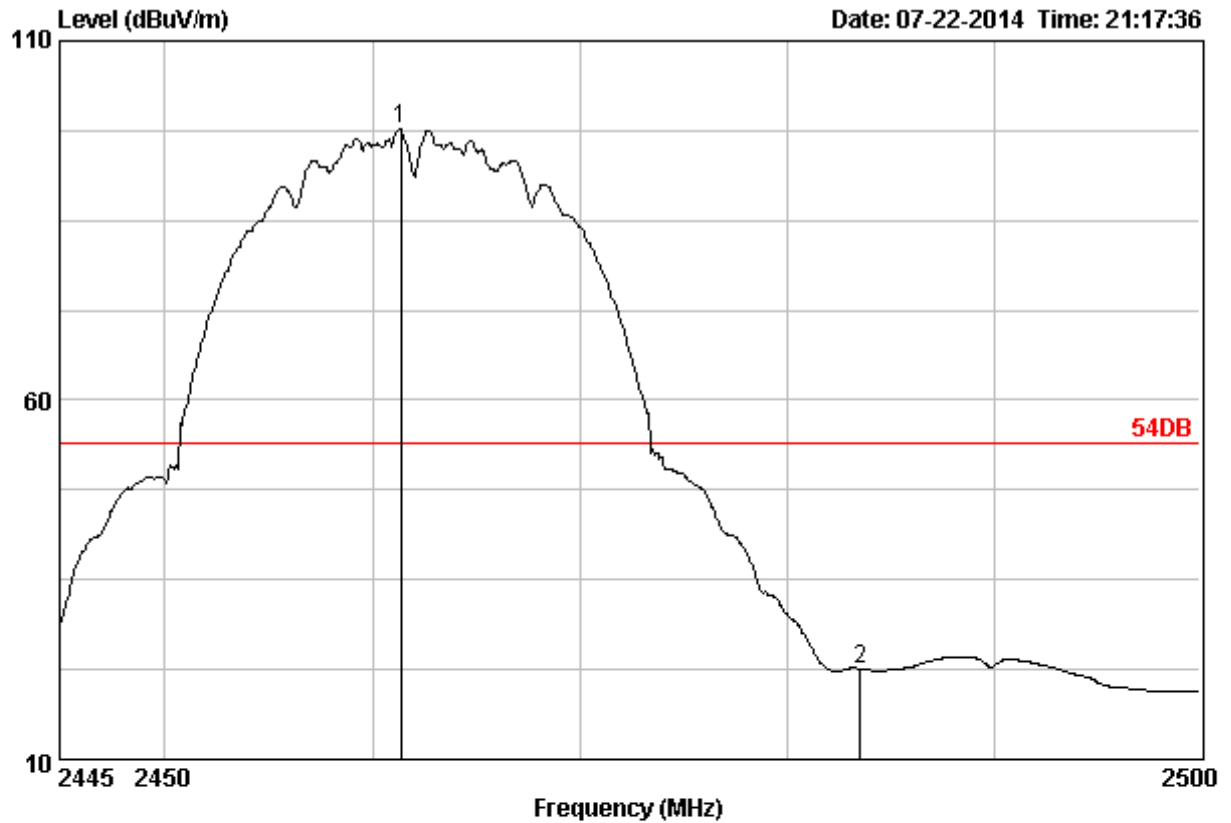

Site no. : 3m Chamber
 Dis. / Ant. : 3m DRH-118
 Limit : 54DB
 Env. / Ins. : 23*C/54%
 Engineer :
 EUT : 802.11b/g/n wireless router
 Power :
 M/N :
 Test Mode :
 Data no. : 327
 Ant. pol. : VERTICAL

	Freq. (MHz)	Ant. Factor (dB)	Cable Loss (dB)	Reading (dBUV)	Emission			Remark
					Level (dBUV/m)	Limits (dBUV/m)	Margin (dB)	
1	2461.34	28.90	4.68	99.46	97.67	54.00	-43.67	Average
2	2483.50	28.93	4.70	24.33	22.58	54.00	31.42	Average

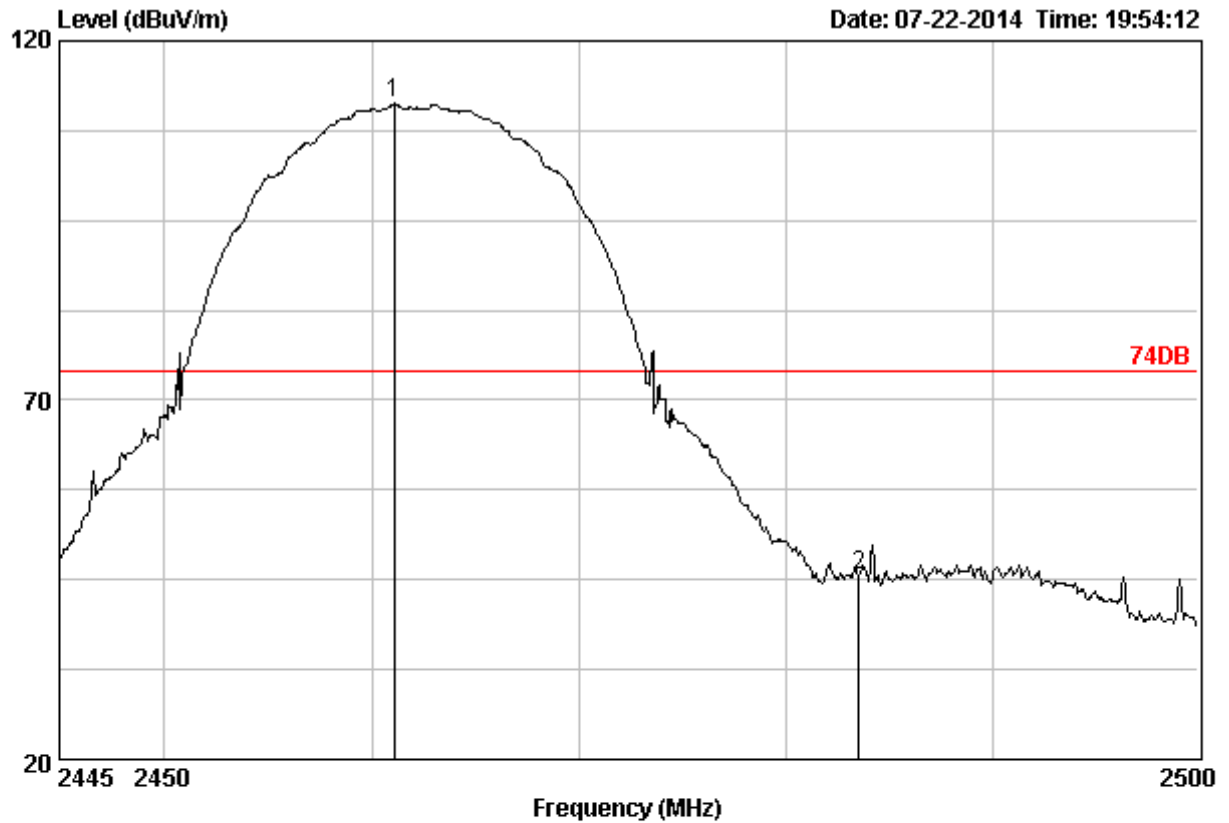

Site no. : 3m Chamber
 Dis. / Ant. : 3m DRH-118
 Limit : 74DB
 Env. / Ins. : 23*C/54%
 Engineer :
 EUT : 802.11b/g/n wireless router
 Power :
 M/N :
 Test Mode :

Data no. : 307
 Ant. pol. : HORIZONTAL

	Freq. (MHz)	Ant. Factor (dB)	Cable Loss (dB)	Reading (dBuV)	Emission			Remark
					Level (dBuV/m)	Limits (dBuV/m)	Margin (dB)	
1	2461.06	28.90	4.68	113.02	111.23	74.00	-37.23	Peak
2	2483.50	28.93	4.70	47.47	45.72	74.00	28.28	Peak

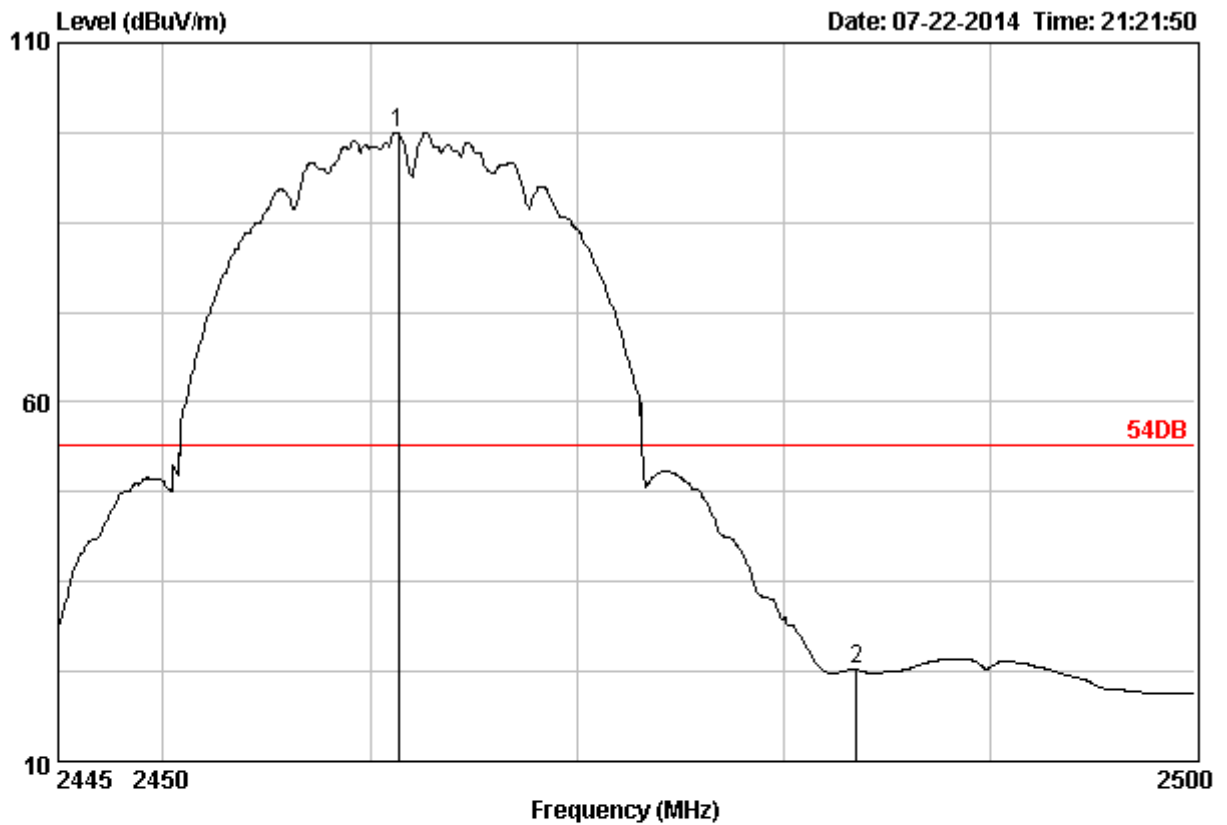

```

Site no.       : 3m Chamber
Dis. / Ant.   : 3m DRH-118
Limit         : 54DB
Env. / Ins.   : 23*C/54%
Engineer      :
EUT           : 802.11b/g/n wireless router
Power         :
M/N           :
Test Mode     :
Data no.      : 328
Ant. pol.     : HORIZONTAL
    
```

	Freq. (MHz)	Ant. Factor (dB)	Cable Loss (dB)	Reading (dBuV)	Emission			Remark
					Level (dBuV/m)	Limits (dBuV/m)	Margin (dB)	
1	2461.34	28.90	4.68	99.39	97.60	54.00	-43.60	Average
2	2483.50	28.93	4.70	24.51	22.76	54.00	31.24	Average

Note : For 802.11g Mode:

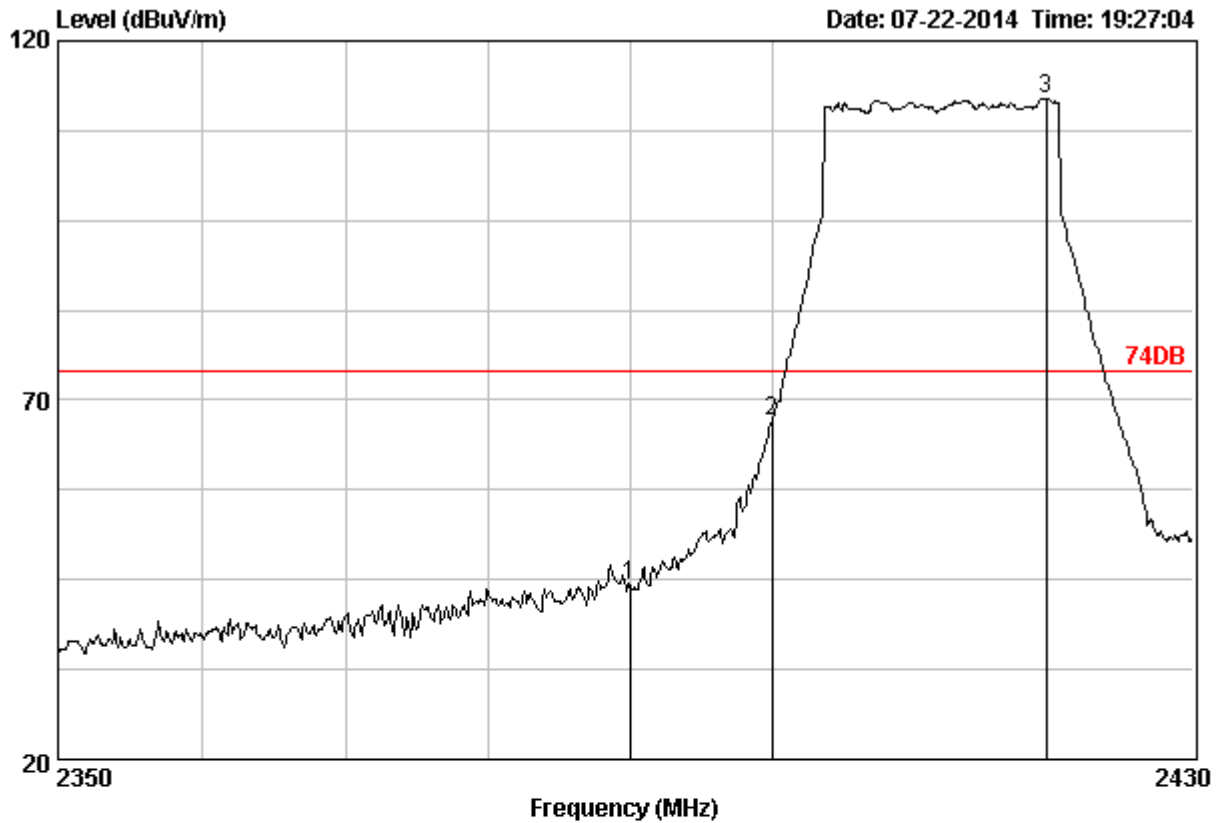

Site no. : 3m Chamber Data no. : 296
 Dis. / Ant. : 3m DRH-118 Ant. pol. : VERTICAL
 Limit : 74DB
 Env. / Ins. : 23*C/54%
 Engineer :
 EUT : 802.11b/g/n wireless router
 Power :
 M/N :
 Test Mode :

	Freq. (MHz)	Ant. Factor (dB)	Cable Loss (dB)	Reading (dBuV)	Emission Level (dBuV/m)	Limits (dBuV/m)	Margin (dB)	Remark
1	2390.00	28.78	4.61	46.22	44.25	74.00	29.75	Peak
2	2400.00	28.78	4.61	69.14	67.17	74.00	6.83	Peak
3	2419.52	28.84	4.64	113.92	112.04	74.00	-38.04	Peak

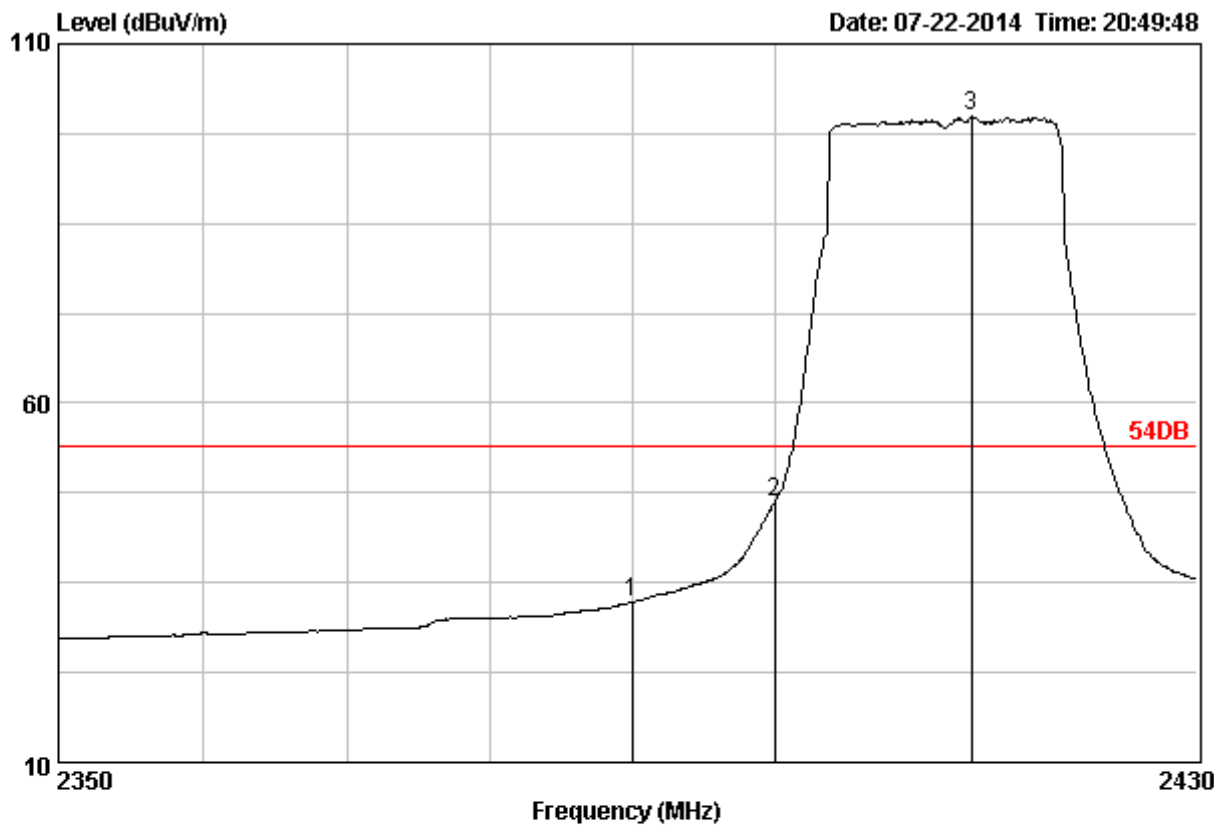

Site no. : 3m Chamber Data no. : 313
 Dis. / Ant. : 3m DRH-118 Ant. pol. : VERTICAL
 Limit : 54DB
 Env. / Ins. : 23*C/54%
 Engineer :
 EUT : 802.11b/g/n wireless router
 Power :
 M/N :
 Test Mode :

	Freq. (MHz)	Ant. Factor (dB)	Cable Loss (dB)	Reading (dBuV)	Emission		Margin (dB)	Remark
					Level (dBuV/m)	Limits (dBuV/m)		
1	2390.00	28.78	4.61	34.29	32.32	54.00	21.68	Average
2	2400.00	28.78	4.61	48.22	46.25	54.00	7.75	Average
3	2413.92	28.81	4.63	101.86	99.94	54.00	-45.94	Average

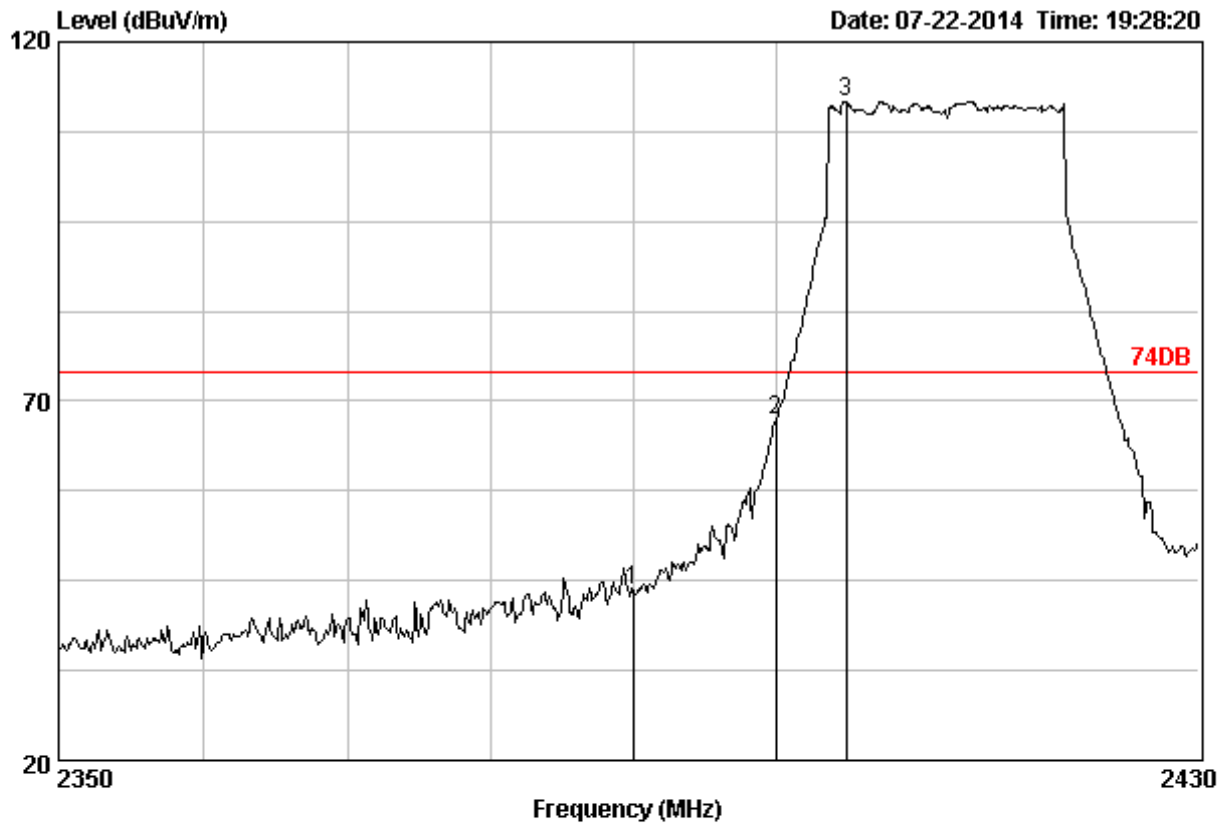

```

Site no.      : 3m Chamber
Dis. / Ant.  : 3m DRH-118
Limit        : 74DB
Env. / Ins.  : 23°C/54%
Engineer     :
EUT          : 802.11b/g/n wireless router
Power        :
M/N          :
Test Mode    :
Data no.     : 297
Ant. pol.    : HORIZONTAL
    
```

Freq. (MHz)	Ant. Factor (dB)	Cable Loss (dB)	Reading (dBuV)	Emission			Margin (dB)	Remark
				Level (dBuV/m)	Limits (dBuV/m)			
1	2390.00	28.78	45.63	43.66	74.00	30.34	Peak	
2	2400.00	28.78	69.29	67.32	74.00	6.68	Peak	
3	2404.96	28.81	113.65	111.73	74.00	-37.73	Peak	

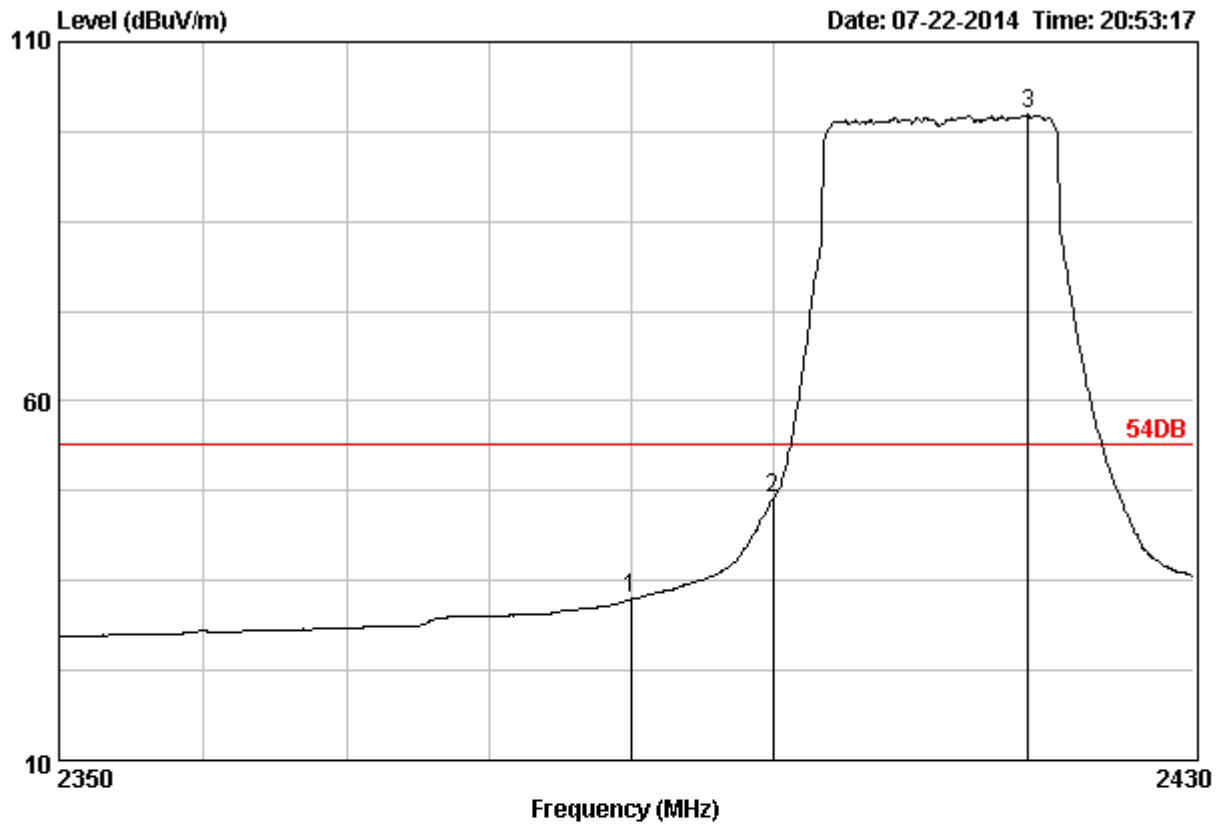

Site no. : 3m Chamber Data no. : 314
 Dis. / Ant. : 3m DRH-118 Ant. pol. : HORIZONTAL
 Limit : 54DB
 Env. / Ins. : 23°C/54%
 Engineer :
 EUT : 802.11b/g/n wireless router
 Power :
 M/N :
 Test Mode :

	Freq. (MHz)	Ant. Factor (dB)	Cable Loss (dB)	Reading (dBuV)	Emission		Margin (dB)	Remark
					Level (dBuV/m)	Limits (dBuV/m)		
1	2390.00	28.78	4.61	34.40	32.43	54.00	21.57	Average
2	2400.00	28.78	4.61	48.37	46.40	54.00	7.60	Average
3	2418.16	28.81	4.63	101.79	99.87	54.00	-45.87	Average

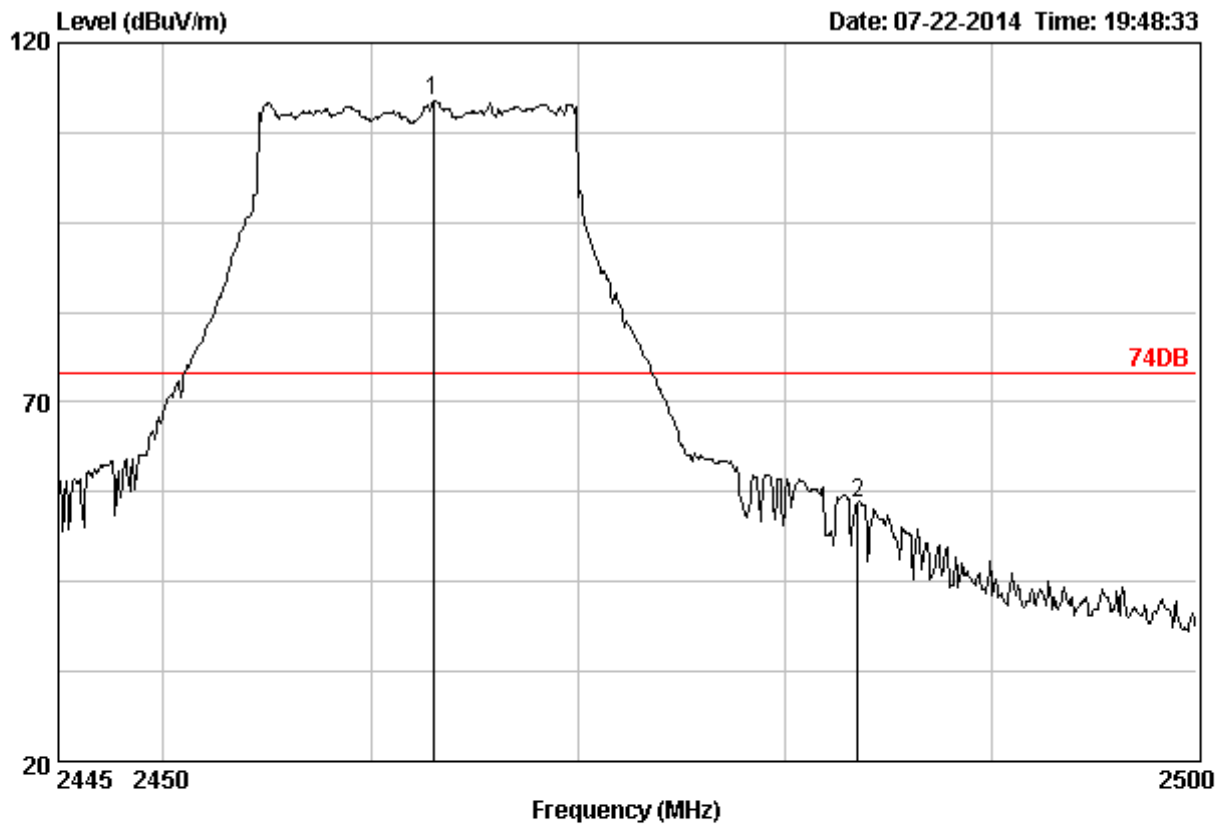

Site no. : 3m Chamber
 Dis. / Ant. : 3m DRH-118
 Limit : 74DB
 Env. / Ins. : 23*C/54%
 Engineer :
 EUT : 802.11b/g/n wireless router
 Power :
 M/N :
 Test Mode :
 Data no. : 304
 Ant. pol. : VERTICAL

Freq. (MHz)	Ant. Factor (dB)	Cable Loss (dB)	Reading (dBUV)	Emission				Remark
				Level (dBUV/m)	Limits (dBUV/m)	Margin (dB)		
1	2462.99	28.90	4.68	113.68	111.89	74.00	-37.89	Peak
2	2483.50	28.93	4.70	57.79	56.04	74.00	17.96	Peak

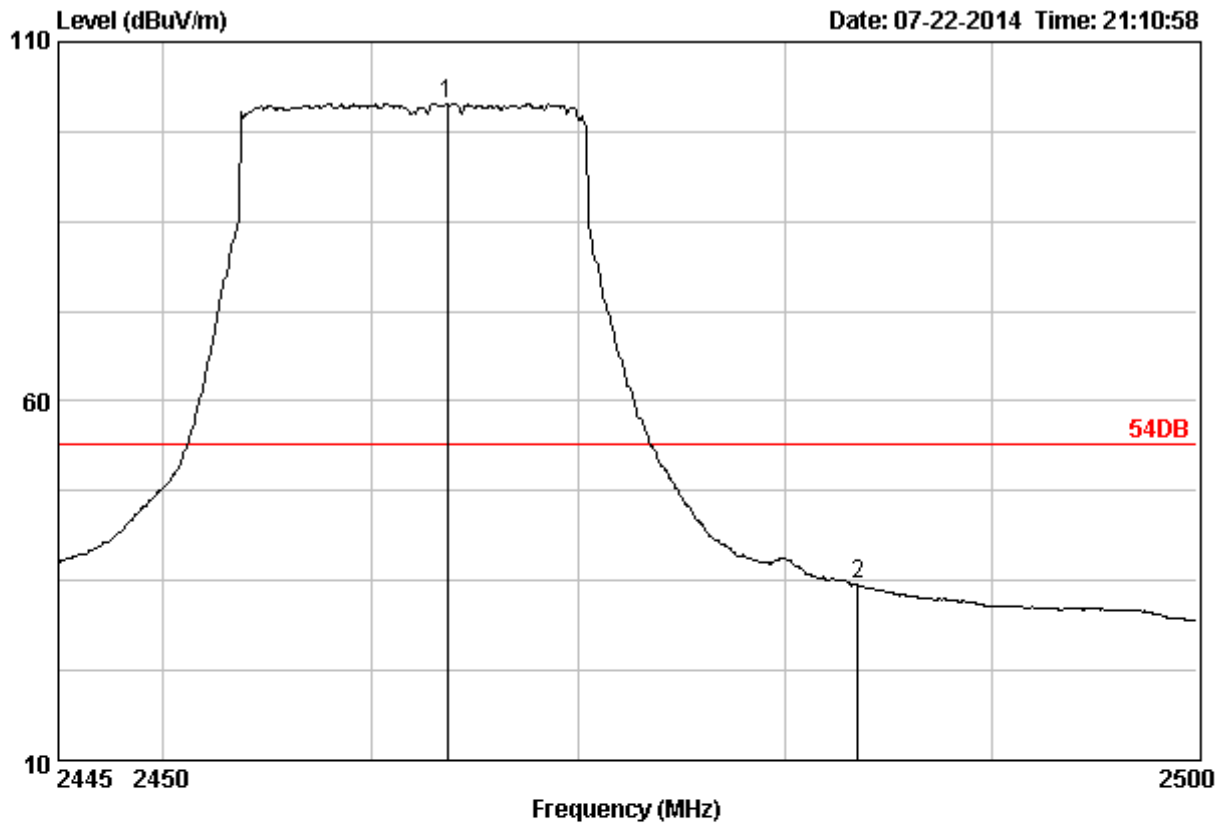

Site no. : 3m Chamber
 Dis. / Ant. : 3m DRH-118
 Limit : 54DB
 Env. / Ins. : 23°C/54%
 Engineer :
 EUT : 802.11b/g/n wireless router
 Power :
 M/N :
 Test Mode :

Data no. : 324
 Ant. pol. : VERTICAL

	Freq. (MHz)	Ant.		Cable		Emission			Remark
		Factor (dB)	Loss (dB)	Reading (dBuV)	Level (dBuV/m)	Limits (dBuV/m)	Margin (dB)		
1	2463.65	28.90	4.68	103.23	101.44	54.00	-47.44	Average	
2	2483.50	28.93	4.70	36.13	34.38	54.00	19.62	Average	

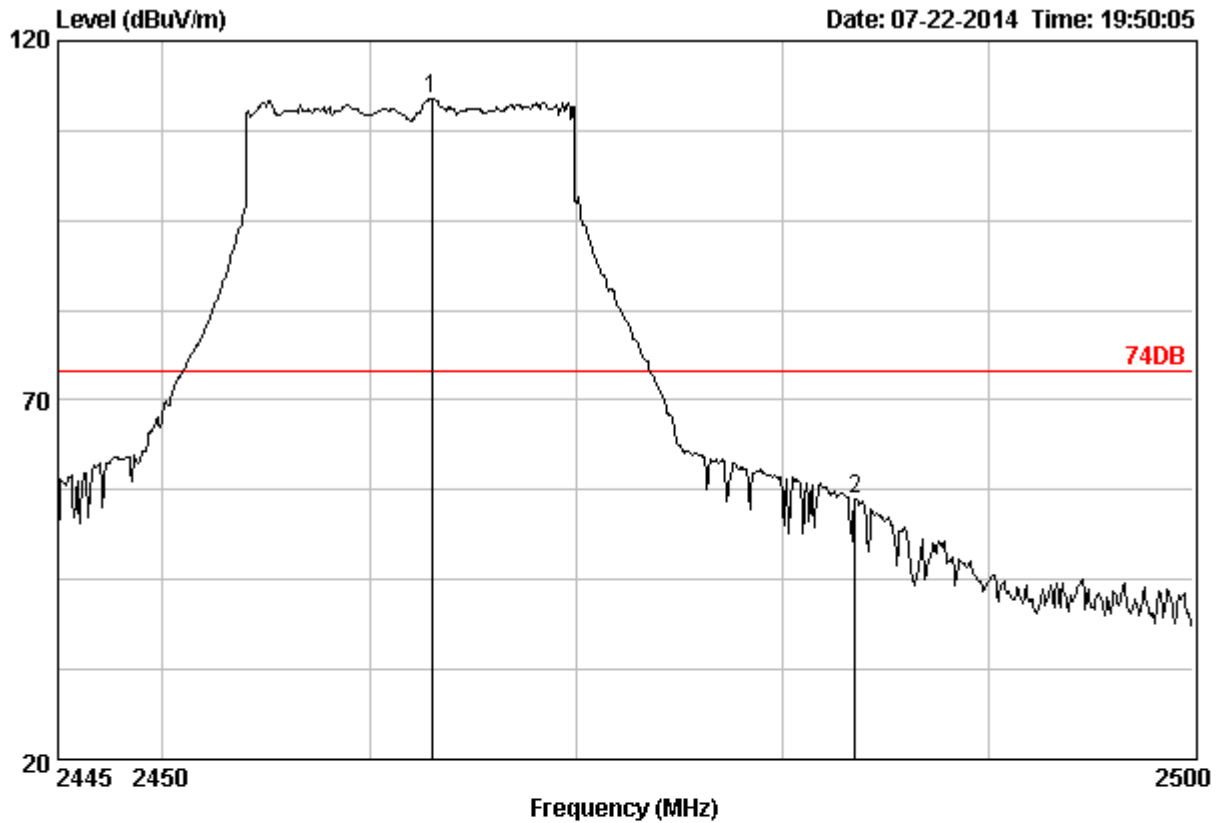

Site no. : 3m Chamber Data no. : 305
 Dis. / Ant. : 3m DRH-118 Ant. pol. : HORIZONTAL
 Limit : 74DB
 Env. / Ins. : 23*C/54%
 Engineer :
 EUT : 802.11b/g/n wireless router
 Power :
 M/N :
 Test Mode :

	Freq. (MHz)	Ant. Factor (dB)	Cable Loss (dB)	Reading (dBuV)	Emission		Margin (dB)	Remark
					Level (dBuV/m)	Limits (dBuV/m)		
1	2462.99	28.90	4.68	113.68	111.89	74.00	-37.89	Peak
2	2483.50	28.93	4.70	57.90	56.15	74.00	17.85	Peak

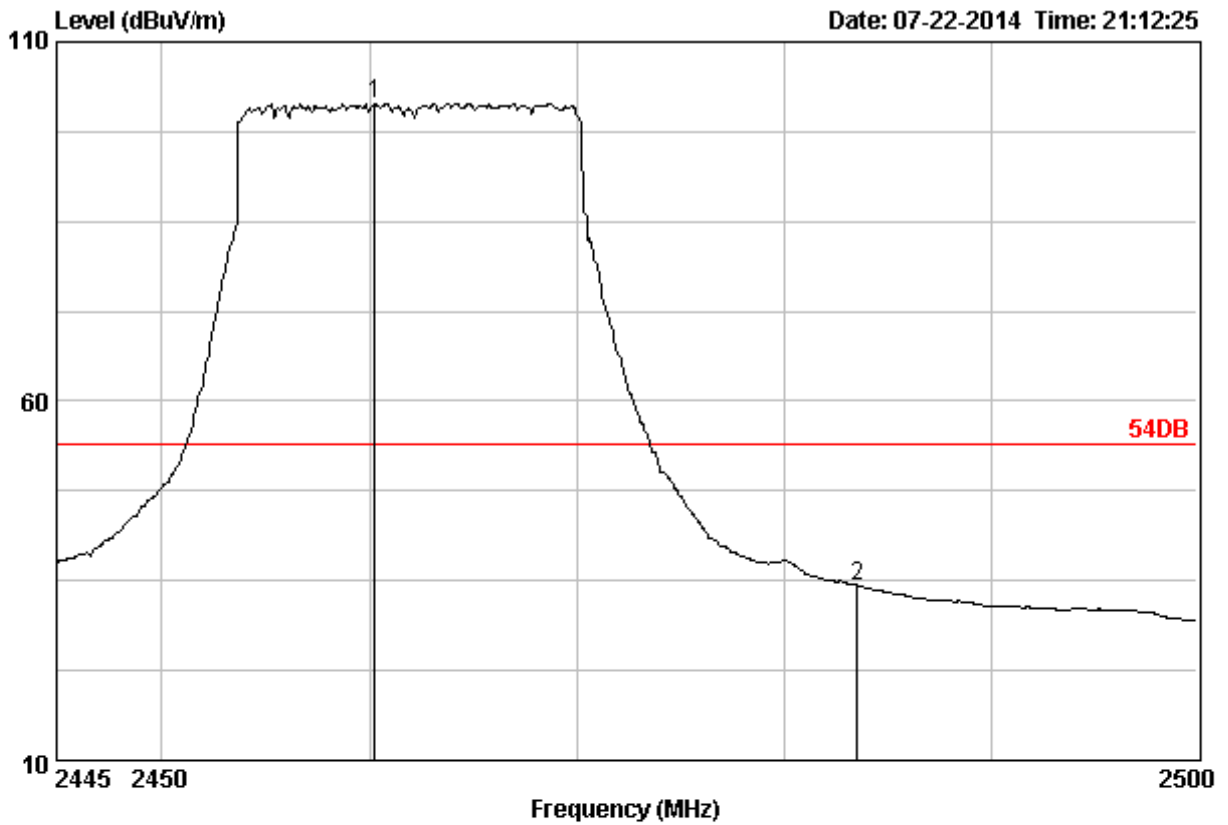

Site no. : 3m Chamber Data no. : 325
 Dis. / Ant. : 3m DRH-118 Ant. pol. : HORIZONTAL
 Limit : 54DB
 Env. / Ins. : 23*C/54%
 Engineer :
 EUT : 802.11b/g/n wireless router
 Power :
 M/N :
 Test Mode :

	Freq. (MHz)	Ant. Factor (dB)	Cable Loss (dB)	Reading (dBuV)	Emission			Remark
					Level (dBuV/m)	Limits (dBuV/m)	Margin (dB)	
1	2460.24	28.90	4.68	103.28	101.49	54.00	-47.49	Average
2	2483.50	28.93	4.70	36.09	34.34	54.00	19.66	Average

Note : For 802.11n (20MHz) Mode:

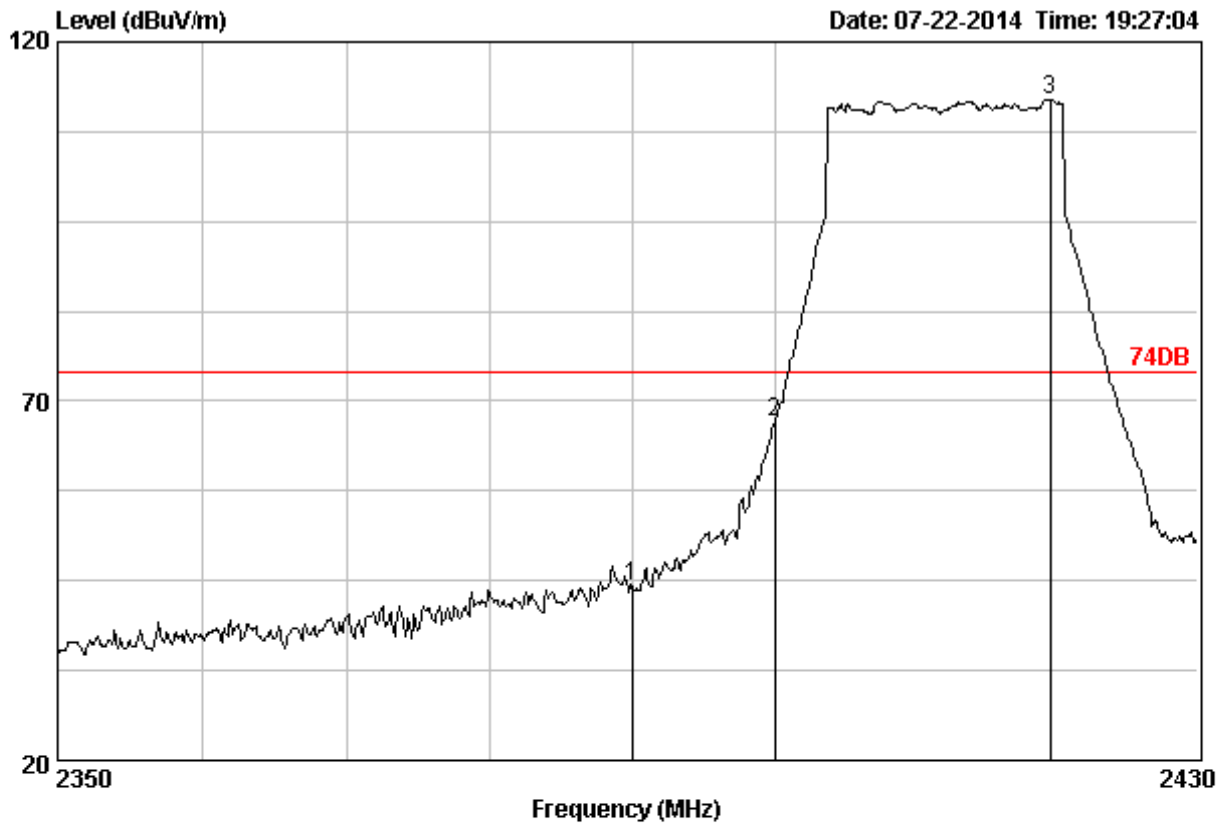

```

Site no.       : 3m Chamber                Data no. : 296
Dis. / Ant.   : 3m DRH-118              Ant. pol.: VERTICAL
Limit         : 74DB
Env. / Ins.   : 23*C/54%
Engineer      :
EUT           : 802.11b/g/n wireless router
Power         :
M/N           :
Test Mode     :
    
```

	Freq. (MHz)	Ant. Factor (dB)	Cable Loss (dB)	Reading (dBuV)	Emission		Margin (dB)	Remark
					Level (dBuV/m)	Limits (dBuV/m)		
1	2390.00	28.78	4.61	46.22	44.25	74.00	29.75	Peak
2	2400.00	28.78	4.61	69.14	67.17	74.00	6.83	Peak
3	2419.52	28.84	4.64	113.92	112.04	74.00	-38.04	Peak

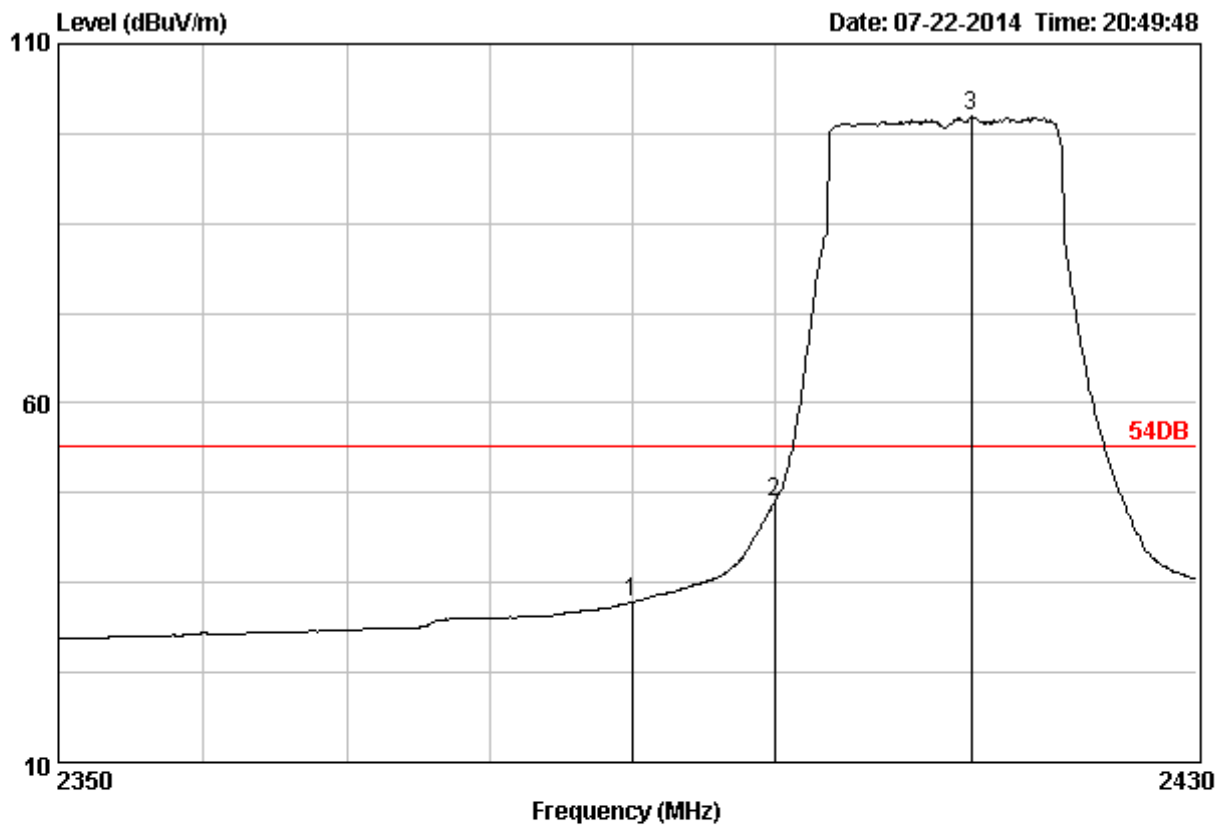

Site no. : 3m Chamber
 Dis. / Ant. : 3m DRH-118
 Limit : 54DB
 Env. / Ins. : 23*C/54%
 Engineer :
 EUT : 802.11b/g/n wireless router
 Power :
 M/N :
 Test Mode :

Data no. : 313
 Ant. pol. : VERTICAL

	Freq. (MHz)	Ant. Factor (dB)	Cable Loss (dB)	Reading (dBuV)	Emission			Remark
					Level (dBuV/m)	Limits (dBuV/m)	Margin (dB)	
1	2390.00	28.78	4.61	34.29	32.32	54.00	21.68	Average
2	2400.00	28.78	4.61	48.22	46.25	54.00	7.75	Average
3	2413.92	28.81	4.63	101.86	99.94	54.00	-45.94	Average

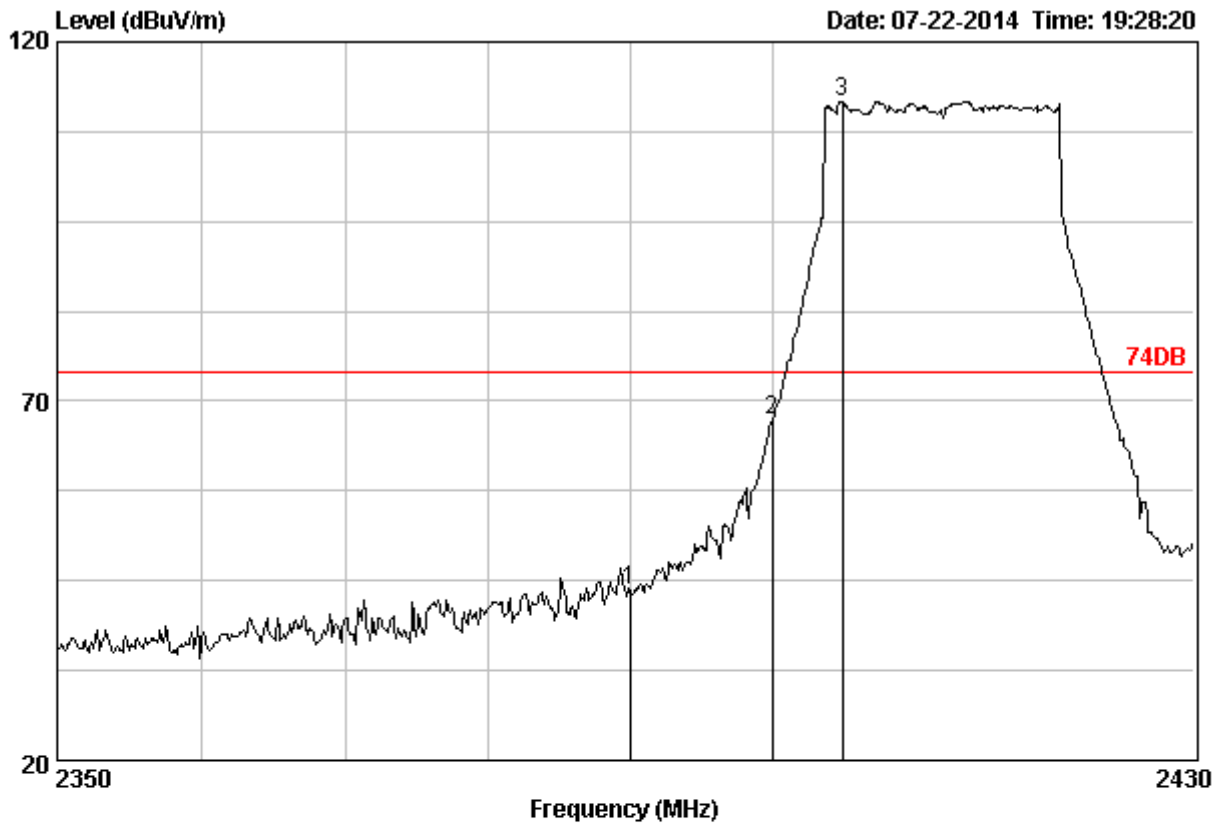

Site no. : 3m Chamber Data no. : 297
 Dis. / Ant. : 3m DRH-118 Ant. pol. : HORIZONTAL
 Limit : 74DB
 Env. / Ins. : 23*C/54%
 Engineer :
 EUT : 802.11b/g/n wireless router
 Power :
 M/N :
 Test Mode :

	Freq. (MHz)	Ant. Factor (dB)	Cable Loss (dB)	Emission			Margin (dB)	Remark
				Reading (dBuV)	Level (dBuV/m)	Limits (dBuV/m)		
1	2390.00	28.78	4.61	45.63	43.66	74.00	30.34	Peak
2	2400.00	28.78	4.61	69.29	67.32	74.00	6.68	Peak
3	2404.96	28.81	4.63	113.65	111.73	74.00	-37.73	Peak

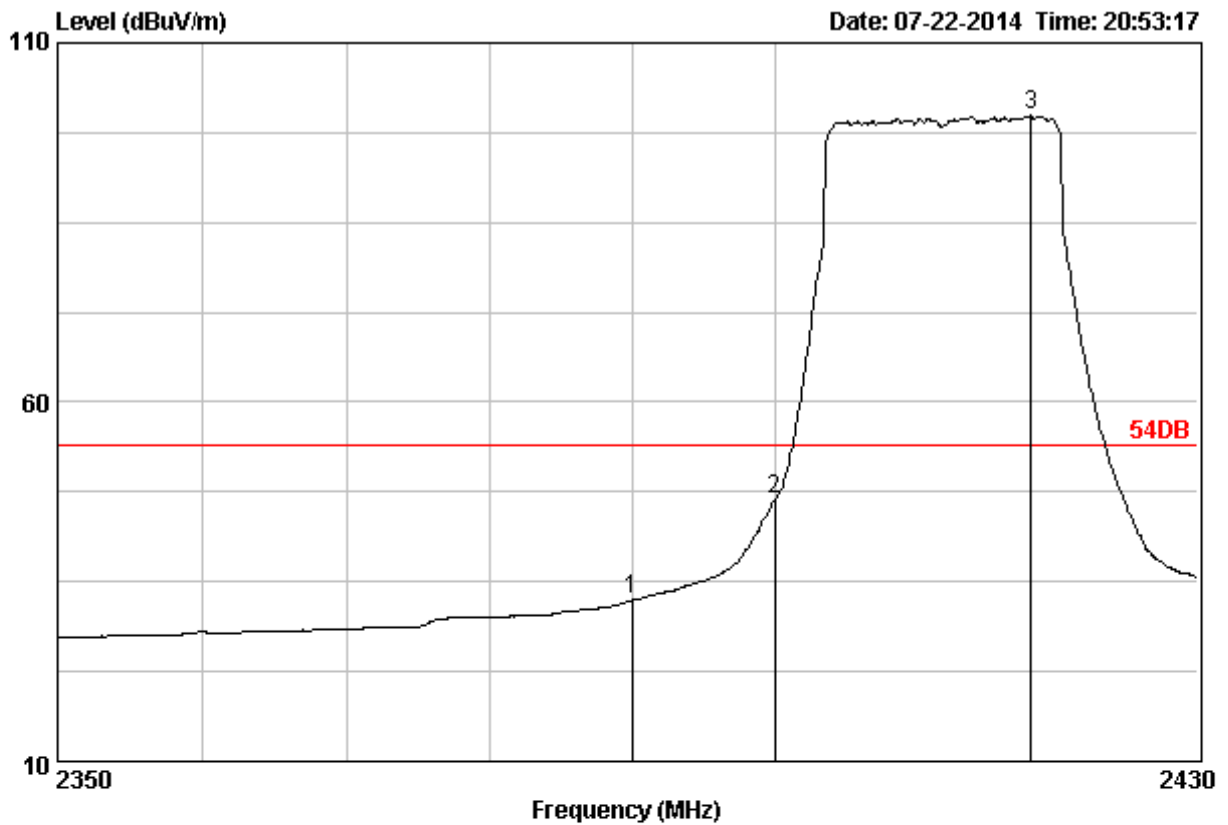

Site no. : 3m Chamber
 Dis. / Ant. : 3m DRH-118
 Limit : 54DB
 Env. / Ins. : 23*C/54%
 Engineer :
 EUT : 802.11b/g/n wireless router
 Power :
 M/N :
 Test Mode :

Data no. : 314
 Ant. pol. : HORIZONTAL

Freq. (MHz)	Ant. Factor (dB)	Cable Loss (dB)	Reading (dBuV)	Emission			Margin (dB)	Remark
				Level (dBuV/m)	Limits (dBuV/m)			
1	2390.00	28.78	4.61	34.40	32.43	54.00	21.57	Average
2	2400.00	28.78	4.61	48.37	46.40	54.00	7.60	Average
3	2418.16	28.81	4.63	101.79	99.87	54.00	-45.87	Average

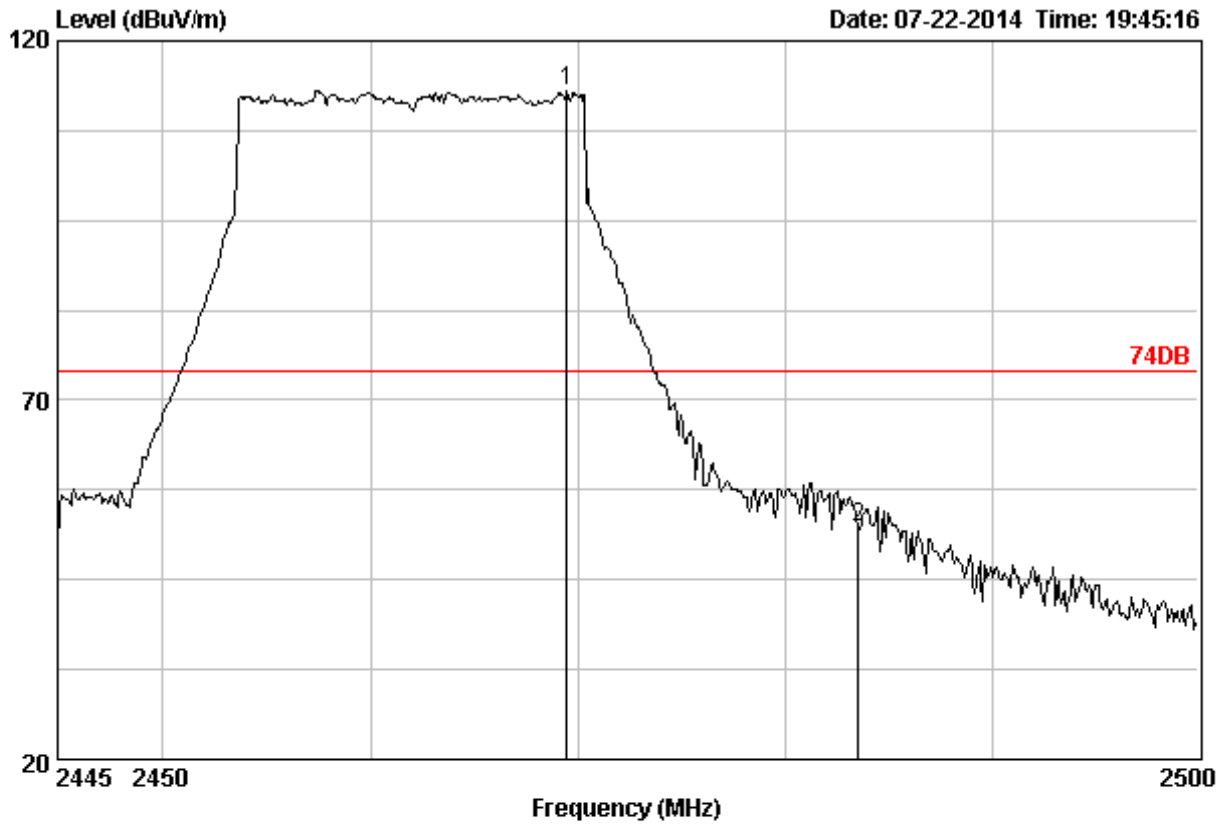

Site no. : 3m Chamber Data no. : 302
 Dis. / Ant. : 3m DRH-118 Ant. pol. : VERTICAL
 Limit : 74DB
 Env. / Ins. : 23*C/54%
 Engineer :
 EUT : 802.11b/g/n wireless router
 Power :
 M/N :
 Test Mode :

	Freq. (MHz)	Ant. Factor (dB)	Cable Loss (dB)	Reading (dBuV)	Emission Level (dBuV/m)	Limits (dBuV/m)	Margin (dB)	Remark
1	2469.42	28.90	4.68	114.78	112.99	74.00	-38.99	Peak
2	2483.50	28.93	4.70	54.14	52.39	74.00	21.61	Peak

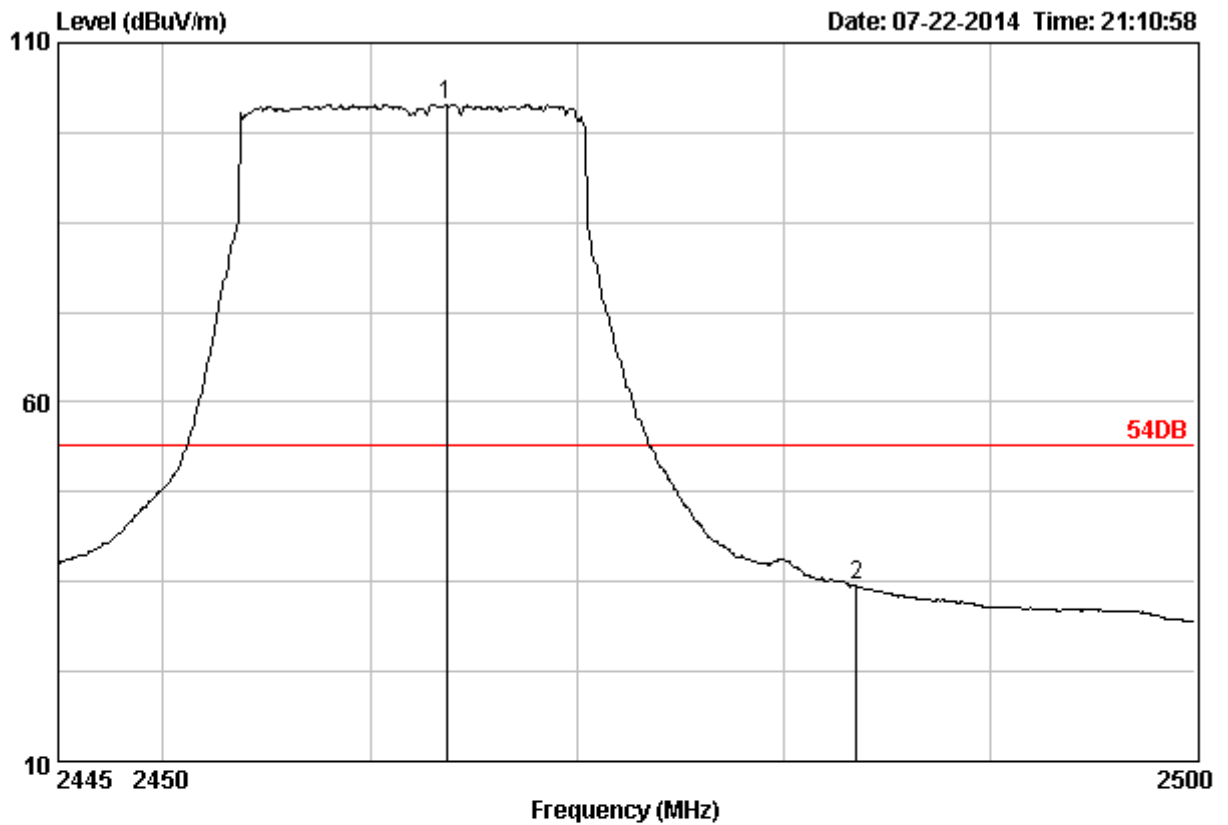

Site no. : 3m Chamber Data no. : 324
 Dis. / Ant. : 3m DRH-118 Ant. pol. : VERTICAL
 Limit : 54DB
 Env. / Ins. : 23*C/54%
 Engineer :
 EUT : 802.11b/g/n wireless router
 Power :
 M/N :
 Test Mode :

	Ant.		Cable		Emission			Remark
	Freq. (MHz)	Factor (dB)	Loss (dB)	Reading (dBuV)	Level (dBuV/m)	Limits (dBuV/m)	Margin (dB)	
1	2463.65	28.90	4.68	103.23	101.44	54.00	-47.44	Average
2	2483.50	28.93	4.70	36.13	34.38	54.00	19.62	Average

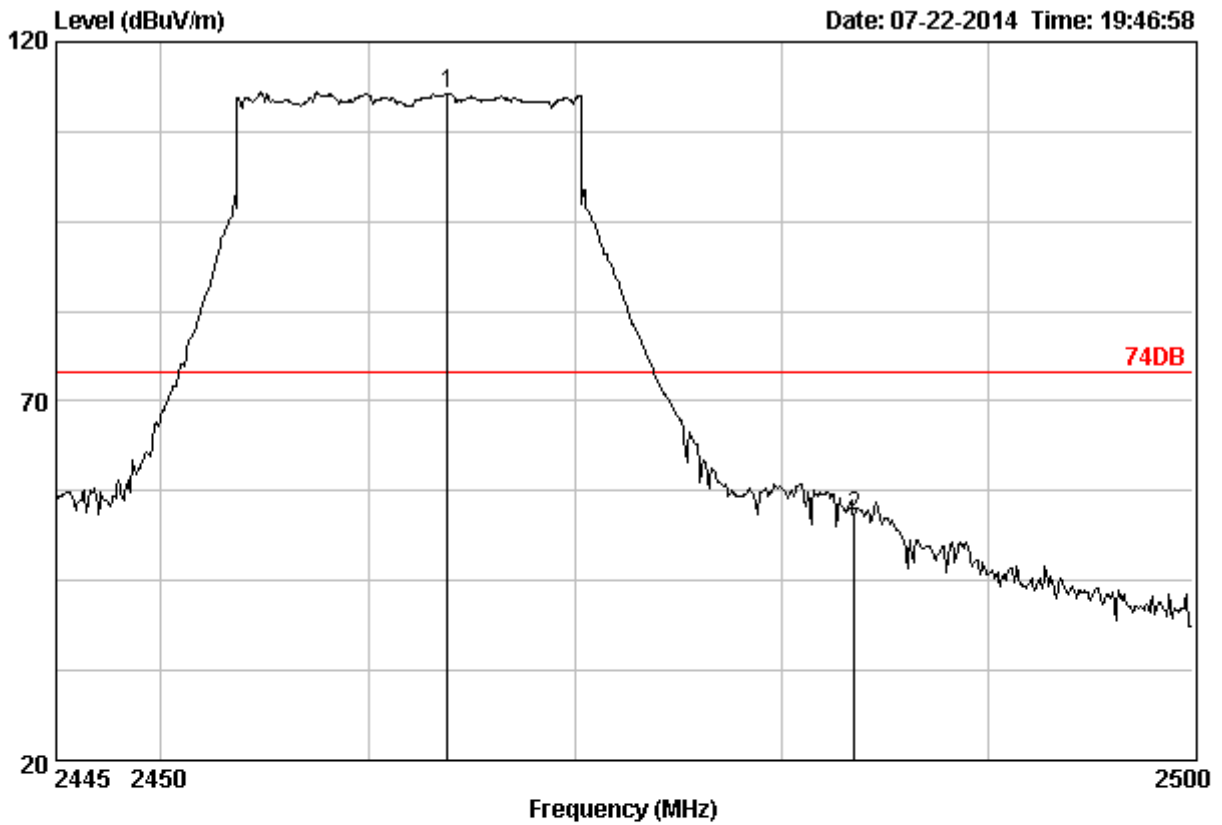

Site no. : 3m Chamber Data no. : 303
 Dis. / Ant. : 3m DRH-118 Ant. pol. : HORIZONTAL
 Limit : 74DB
 Env. / Ins. : 23°C/54%
 Engineer :
 EUT : 802.11b/g/n wireless router
 Power :
 M/N :
 Test Mode :

	Freq. (MHz)	Ant. Factor (dB)	Cable Loss (dB)	Reading (dBuV)	Emission			Remark
					Level (dBuV/m)	Limits (dBuV/m)	Margin (dB)	
1	2463.81	28.90	4.68	114.55	112.76	74.00	-38.76	Peak
2	2483.50	28.93	4.70	55.68	53.93	74.00	20.07	Peak

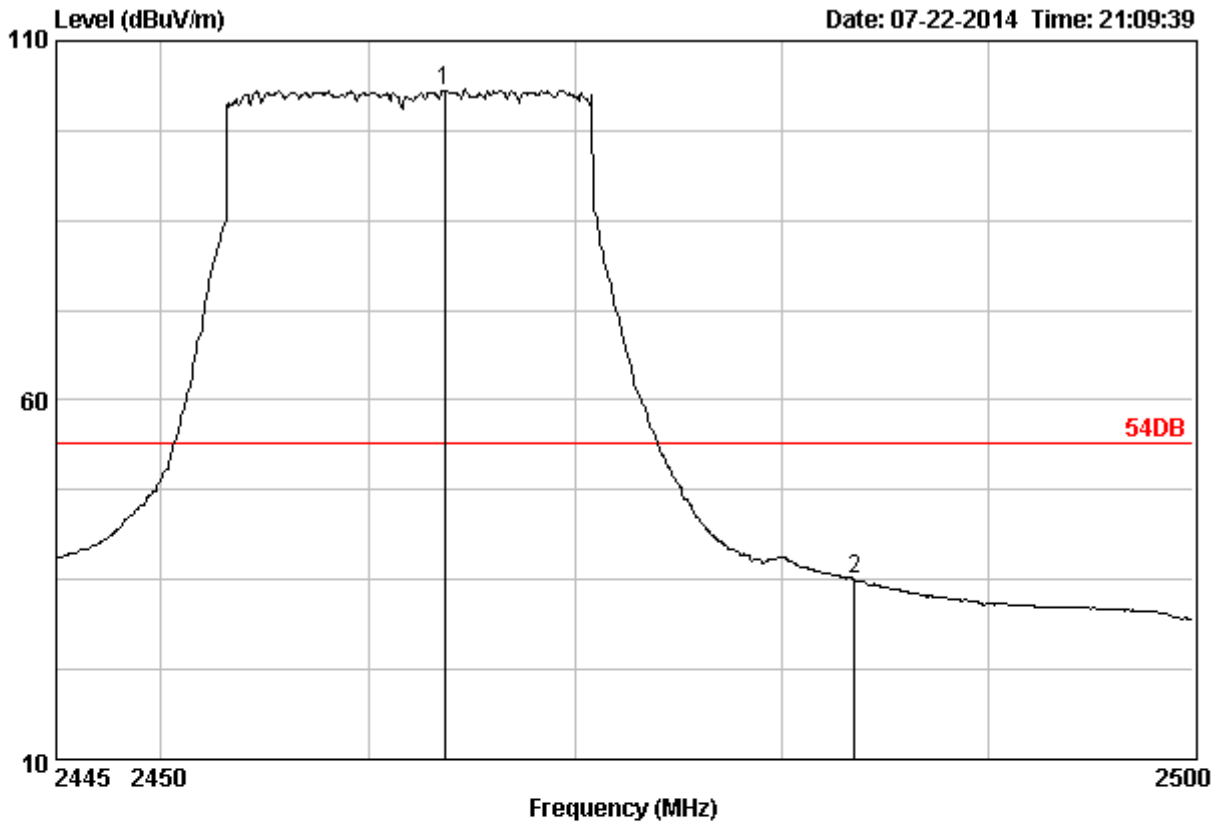

Site no. : 3m Chamber Data no. : 323
 Dis. / Ant. : 3m DRH-118 Ant. pol. : HORIZONTAL
 Limit : 54DB
 Env. / Ins. : 23*C/54%
 Engineer :
 EUT : 802.11b/g/n wireless router
 Power :
 M/N :
 Test Mode :

	Freq. (MHz)	Ant. Factor (dB)	Cable Loss (dB)	Reading (dBuV)	Emission			Remark
					Level (dBuV/m)	Limits (dBuV/m)	Margin (dB)	
1	2463.65	28.90	4.68	104.86	103.07	54.00	-49.07	Average
2	2483.50	28.93	4.70	36.75	35.00	54.00	19.00	Average

Note : For 802.11n (40MHz) Mode:

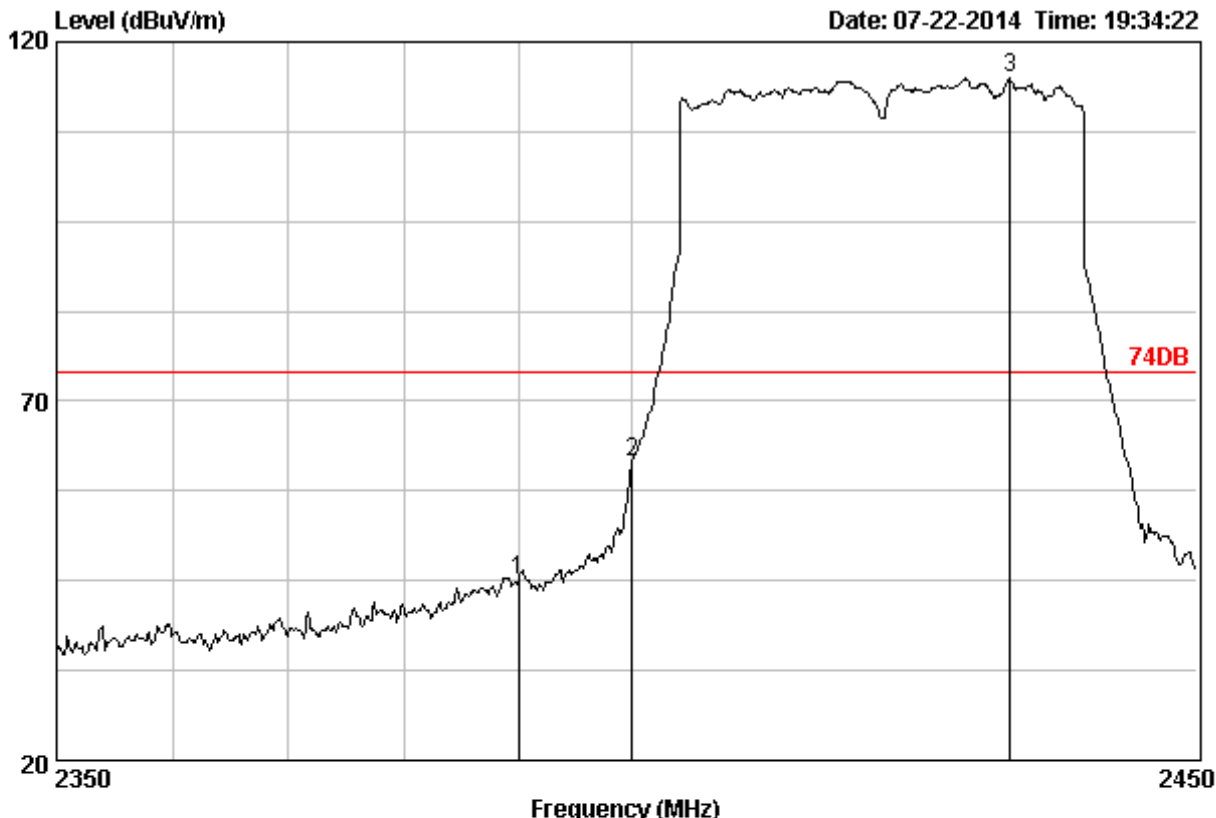

```

Site no.       : 3m Chamber                Data no. : 298
Dis. / Ant.   : 3m DRH-118              Ant. pol. : HORIZONTAL
Limit         : 74DB
Env. / Ins.   : 23*C/54%
Engineer      :
EUT           : 802.11b/g/n wireless router
Power         :
M/N           :
Test Mode     :
    
```

	Freq. (MHz)	Ant. Cable		Emission				Remark
		Factor (dB)	Loss (dB)	Reading (dBUV)	Level (dBUV/m)	Limits (dBUV/m)	Margin (dB)	
1	2390.00	28.78	4.61	47.07	45.10	74.00	28.90	Peak
2	2400.00	28.78	4.61	63.44	61.47	74.00	12.53	Peak
3	2433.40	28.84	4.64	116.92	115.03	74.00	-41.03	Peak

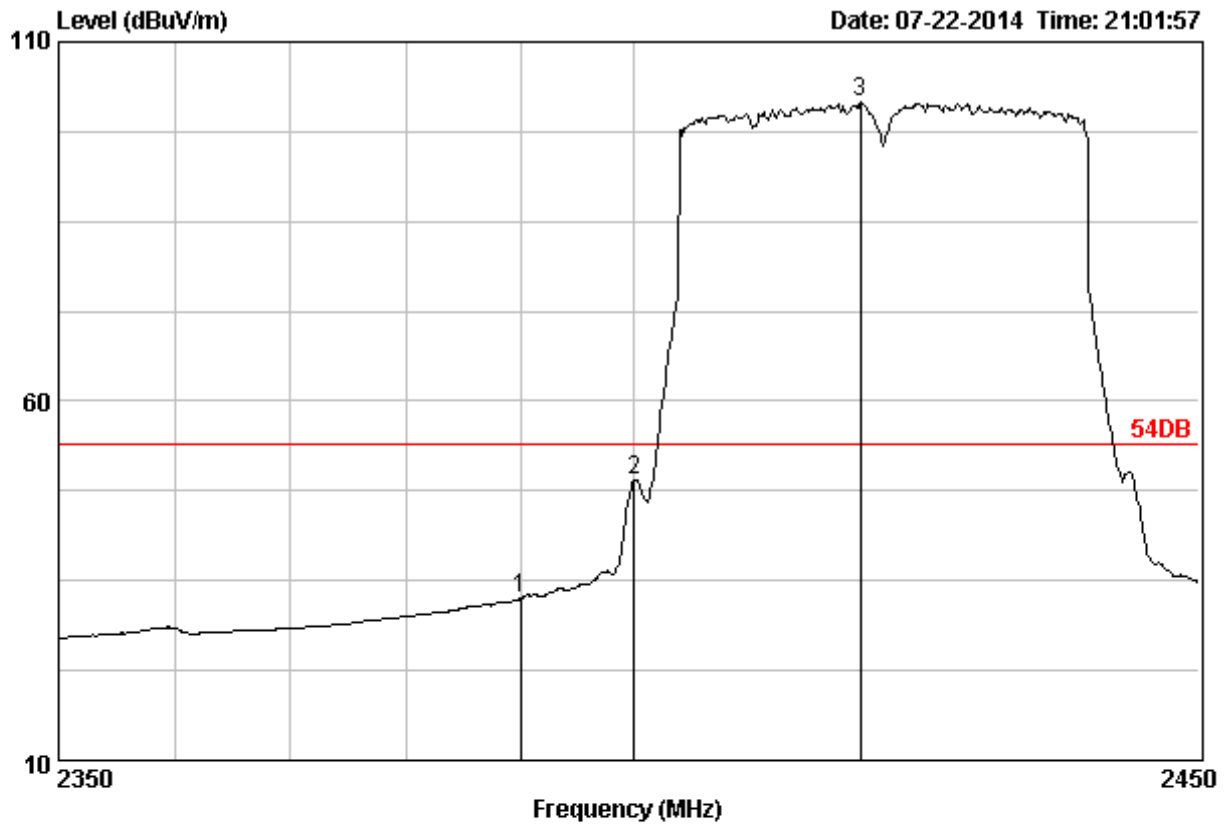

Site no. : 3m Chamber Data no. : 318
 Dis. / Ant. : 3m DRH-118 Ant. pol. : HORIZONTAL
 Limit : 54DB
 Env. / Ins. : 23°C/54%
 Engineer :
 EUT : 802.11b/g/n wireless router
 Power :
 M/N :
 Test Mode :

	Freq. (MHz)	Ant. Factor (dB)	Cable Loss (dB)	Reading (dBUV)	Emission			Remark
					Level (dBUV/m)	Limits (dBUV/m)	Margin (dB)	
1	2390.00	28.78	4.61	34.48	32.51	54.00	21.49	Average
2	2400.00	28.78	4.61	50.99	49.02	54.00	4.98	Average
3	2419.90	28.84	4.64	103.42	101.54	54.00	-47.54	Average

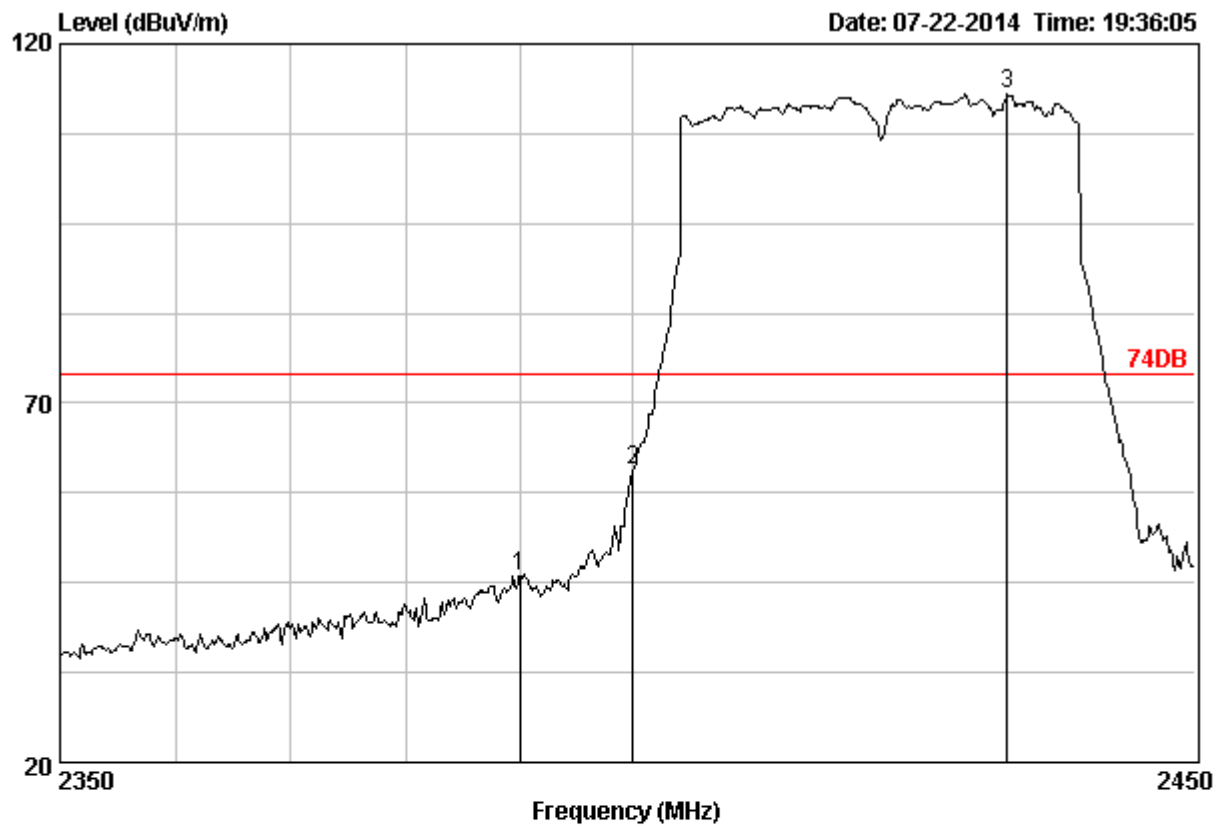

Site no. : 3m Chamber Data no. : 299
 Dis. / Ant. : 3m DRH-118 Ant. pol. : VERTICAL
 Limit : 74DB
 Env. / Ins. : 23°C/54%
 Engineer :
 EUT : 802.11b/g/n wireless router
 Power :
 M/N :
 Test Mode :

	Freq.	Ant.	Cable	Emission		Margin	Remark	
	(MHz)	Factor	Loss	Reading	Level	Limits		
		(dB)	(dB)	(dBuV)	(dBuV/m)	(dBuV/m)	(dB)	
1	2390.00	28.78	4.61	47.74	45.77	74.00	28.23	Peak
2	2400.00	28.78	4.61	62.57	60.60	74.00	13.40	Peak
3	2433.20	28.84	4.64	114.82	112.93	74.00	-38.93	Peak

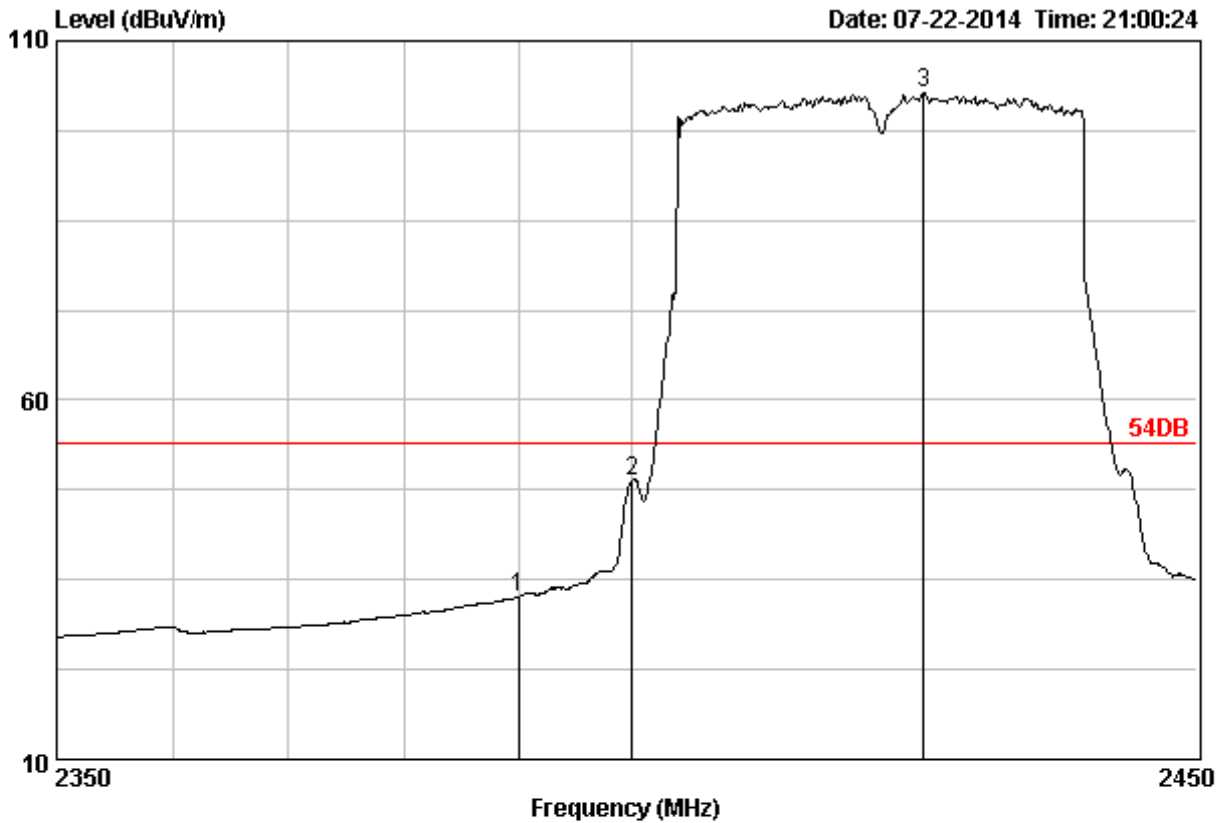

Site no. : 3m Chamber
 Dis. / Ant. : 3m DRH-118
 Limit : 54DB
 Env. / Ins. : 23*C/54%
 Engineer :
 EUT : 802.11b/g/n wireless router
 Power :
 M/N :
 Test Mode :

Data no. : 317
 Ant. pol. : VERTICAL

Freq. (MHz)	Ant. Factor (dB)	Cable Loss (dB)	Reading (dBuV)	Emission		Margin (dB)	Remark	
				Level (dBuV/m)	Limits (dBuV/m)			
1	2390.00	28.78	4.61	34.61	32.64	54.00	21.36	Average
2	2400.00	28.78	4.61	50.78	48.81	54.00	5.19	Average
3	2425.70	28.84	4.64	104.64	102.76	54.00	-48.76	Average

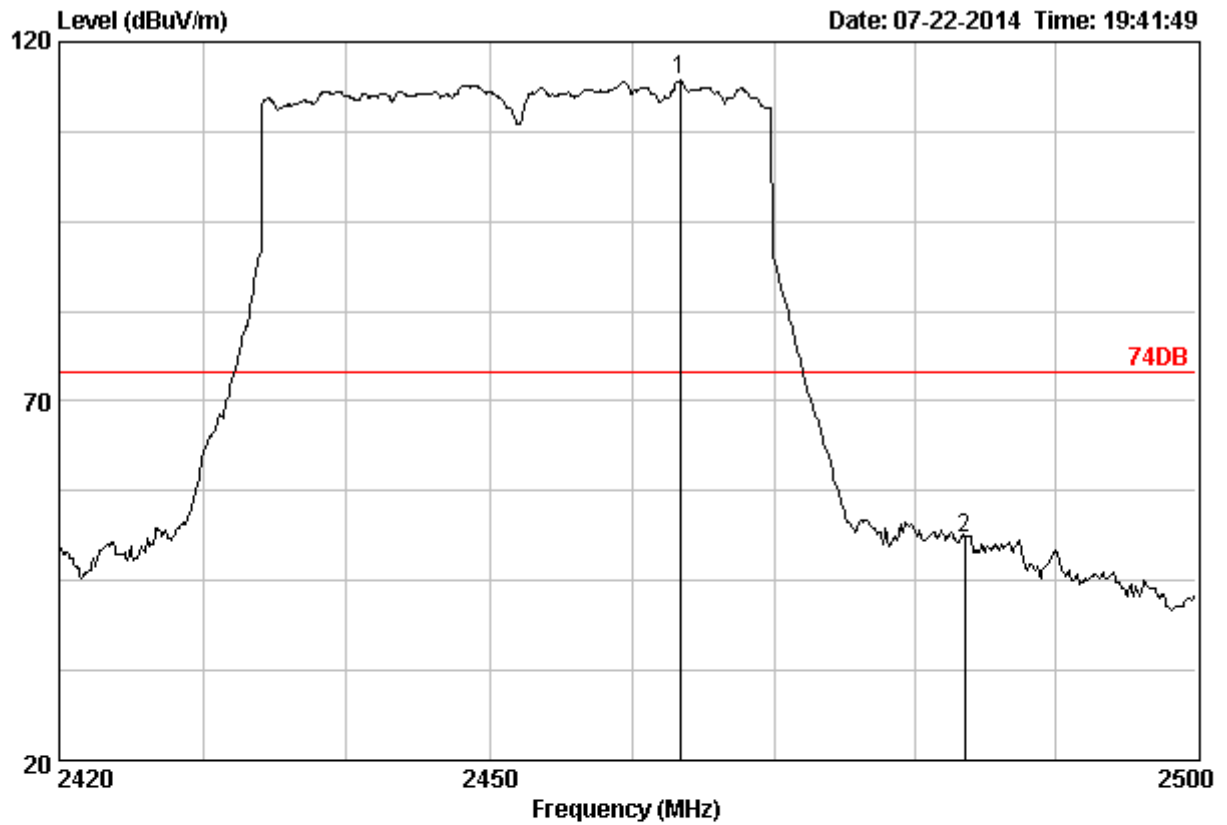

```

Site no.      : 3m Chamber                Data no. : 300
Dis. / Ant.  : 3m DRH-118                Ant. pol. : VERTICAL
Limit        : 74DB
Env. / Ins.  : 23*C/54%
Engineer     :
EUT          : 802.11b/g/n wireless router
Power        :
M/N          :
Test Mode    :
    
```

	Freq. (MHz)	Ant. Factor (dB)	Cable Loss (dB)	Reading (dBuV)	Emission			Remark
					Level (dBuV/m)	Limits (dBuV/m)	Margin (dB)	
1	2463.36	28.90	4.68	116.39	114.60	74.00	-40.60	Peak
2	2483.50	28.93	4.70	52.77	51.02	74.00	22.98	Peak

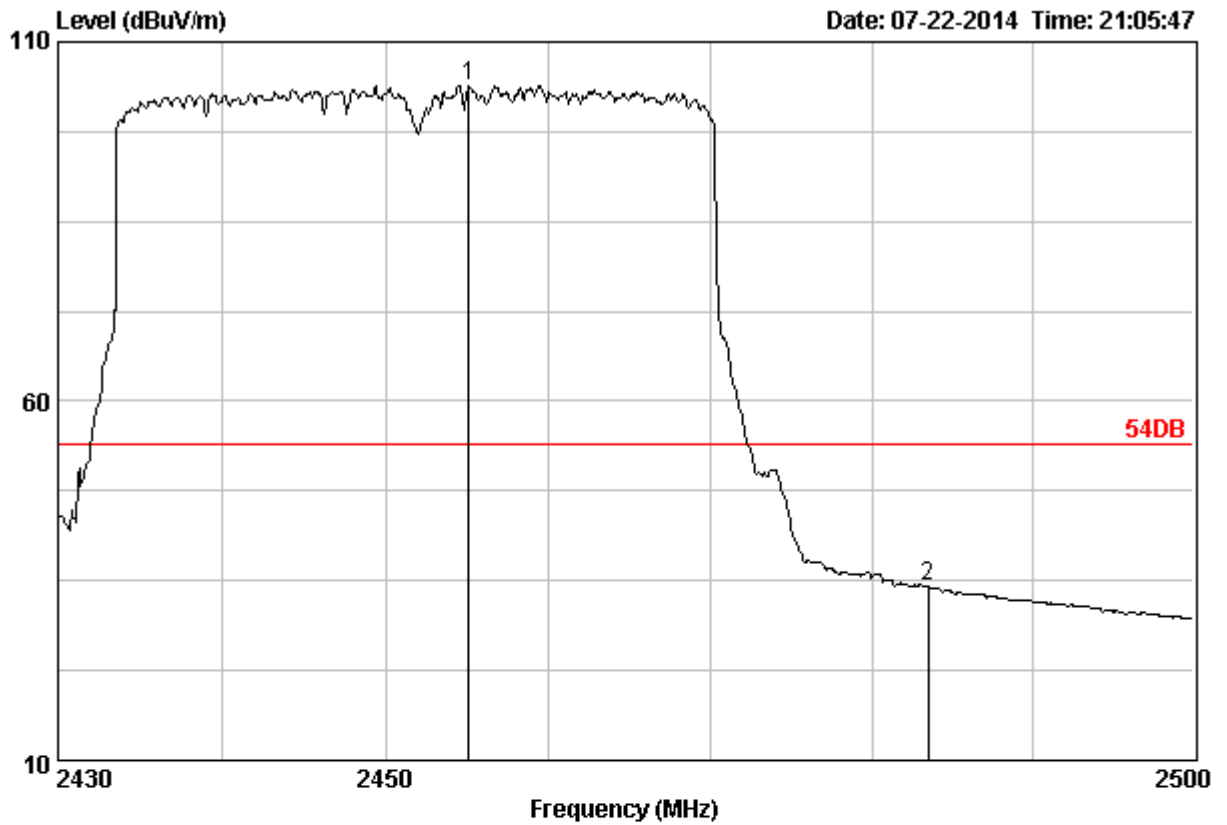

```

Site no.       : 3m Chamber
Dis. / Ant.   : 3m DRH-118
Limit         : 54DB
Env. / Ins.   : 23°C/54%
Engineer      :
SUT           : 802.11b/g/n wireless router
Power         :
M/N          :
Test Mode     :
Data no.      : 321
Ant. pol.     : VERTICAL
    
```

	Freq. (MHz)	Ant. Factor (dB)	Cable Loss (dB)	Reading (dBuV)	Emission			Remark
					Level (dBuV/m)	Limits (dBuV/m)	Margin (dB)	
1	2455.13	28.90	4.68	105.70	103.91	54.00	-49.91	Average
2	2483.50	28.93	4.70	35.94	34.19	54.00	19.81	Average

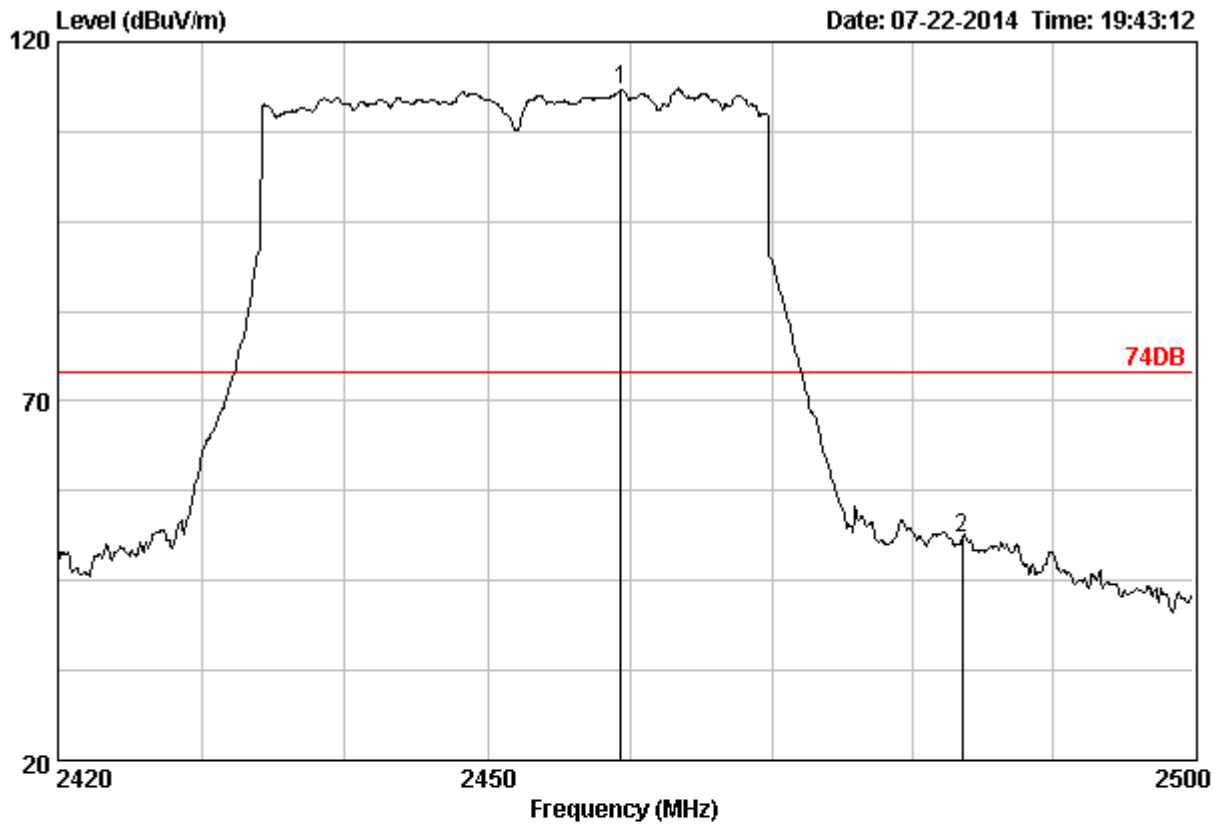

```

te no.      : 3m Chamber                      Data no. : 301
s. / Ant.   : 3m DRH-118                    Ant. pol. : HORIZONTAL
mit         : 74DB
v. / Ins.   : 23*C/54%
gineer      :
T           : 802.11b/g/n wireless router
wer         :
N           :
st Mode     :
    
```

	Freq. (MHz)	Ant. Cable		Emission				Remark
		Factor (dB)	Loss (dB)	Reading (dBuV)	Level (dBuV/m)	Limits (dBuV/m)	Margin (dB)	
1	2459.36	28.90	4.68	115.20	113.41	74.00	-39.41	Peak
2	2483.50	28.93	4.70	52.81	51.06	74.00	22.94	Peak

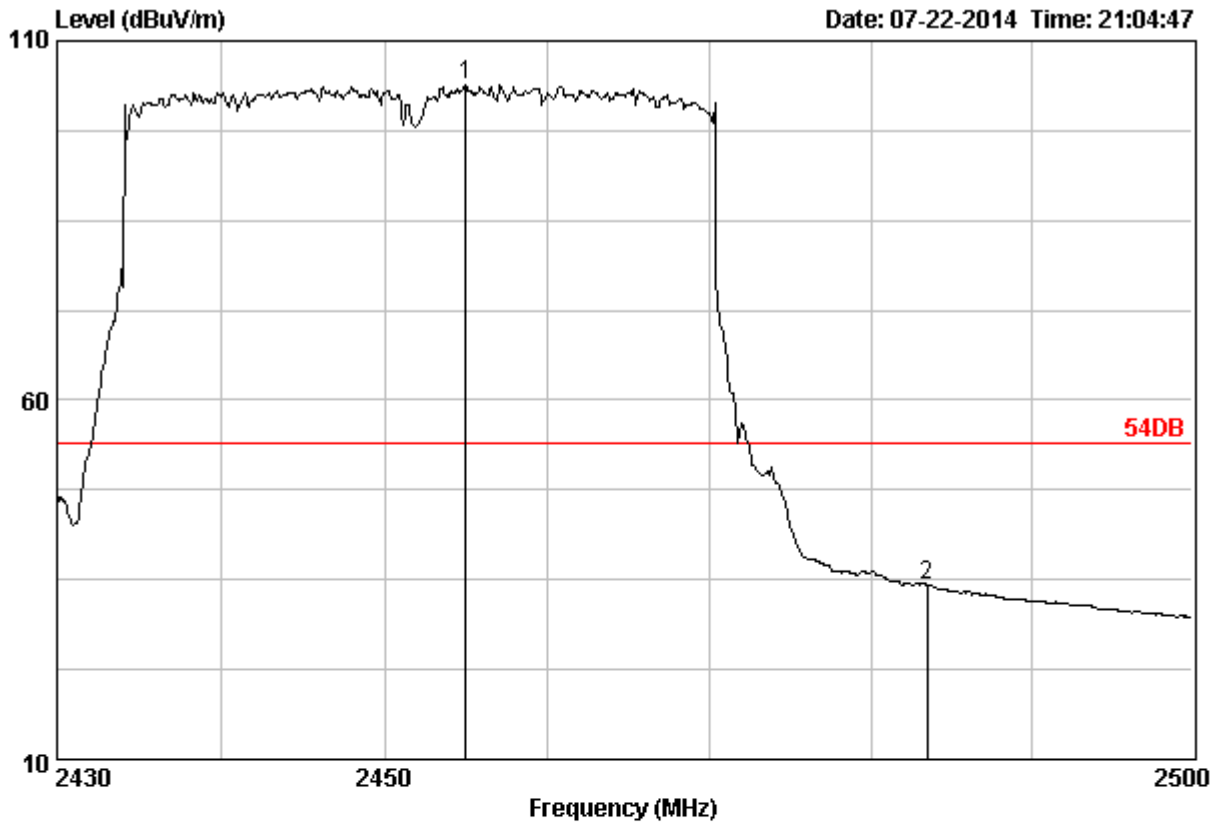

Site no. : 3m Chamber
 Dis. / Ant. : 3m DRH-118
 Limit : 54DB
 Env. / Ins. : 23*C/54%
 Engineer :
 EUT : 802.11b/g/n wireless router
 Power :
 M/N :
 Test Mode :
 Data no. : 320
 Ant. pol. : HORIZONTAL

	Freq. (MHz)	Ant. Factor (dB)	Cable Loss (dB)	Emission				Remark
				Reading (dBuV)	Level (dBuV/m)	Limits (dBuV/m)	Margin (dB)	
1	2454.99	28.90	4.68	105.66	103.87	54.00	-49.87	Average
2	2483.50	28.93	4.70	36.05	34.30	54.00	19.70	Average

4.6. Power Spectral Density Measurement

TEST CONFIGURATION

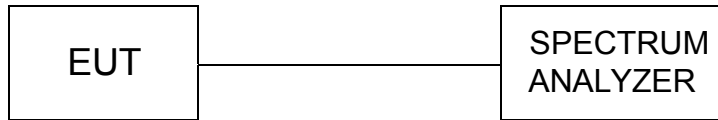

TEST PROCEDURE

The EUT was tested according to KDB558074 D01 v03r02 for compliance to FCC 47CFR 15.247 requirements. Set RBW= 3 kHz, VBW \geq 10KHz, SPAN to 1.5 times greater than the EBW,.

LIMIT

For digitally modulated systems, the power spectral density conducted from the intentional radiator to the antenna shall not be greater than 8 dBm in any 3 kHz band during any time interval of continuous transmission.

TEST RESULTS

Channel	Wi-Fi Standard	Channel Frequency (MHz)	PSD (dBm/3KHz)			Maximum limit (dBm)	PASS / FAIL
			Ant1	Ant 2	Total		
1	802.11b	2412	-8.969	-10.21	N/A	8	PASS
6		2437	-7.954	-10.53	N/A	8	PASS
11		2462	-8.425	-10.12	N/A	8	PASS
1	802.11g	2412	-10.74	-10.37	N/A	8	PASS
6		2437	-11.11	-11.36	N/A	8	PASS
11		2462	-11.12	-10.32	N/A	8	PASS
1	802.11n HT20	2412	-11.53	-11.01	-8.25	8	PASS
6		2437	-11.14	-11.51	-8.31	8	PASS
11		2462	-12.12	-8.237	-6.75	8	PASS
3	802.11n HT40	2422	-12.13	-11.66	-8.88	8	PASS
6		2437	-12.55	-12.39	-9.46	8	PASS
9		2452	-12.06	-12.82	-9.41	8	PASS

For 802.11b Mode:

CH1 @ANT 1

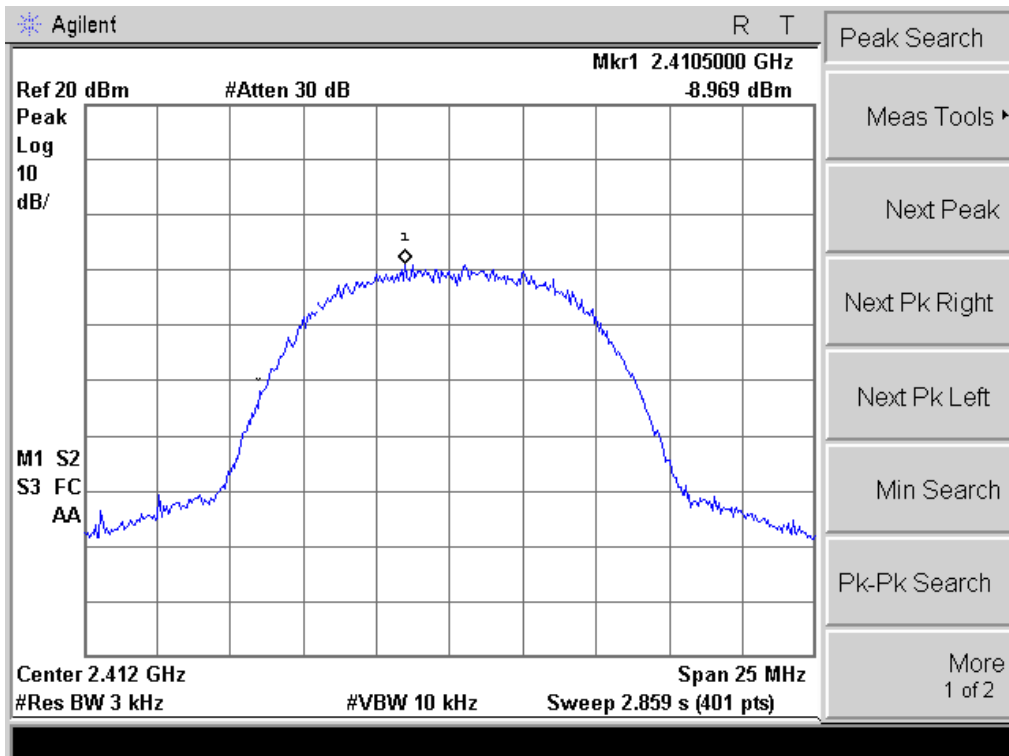

CH1 @ANT 2

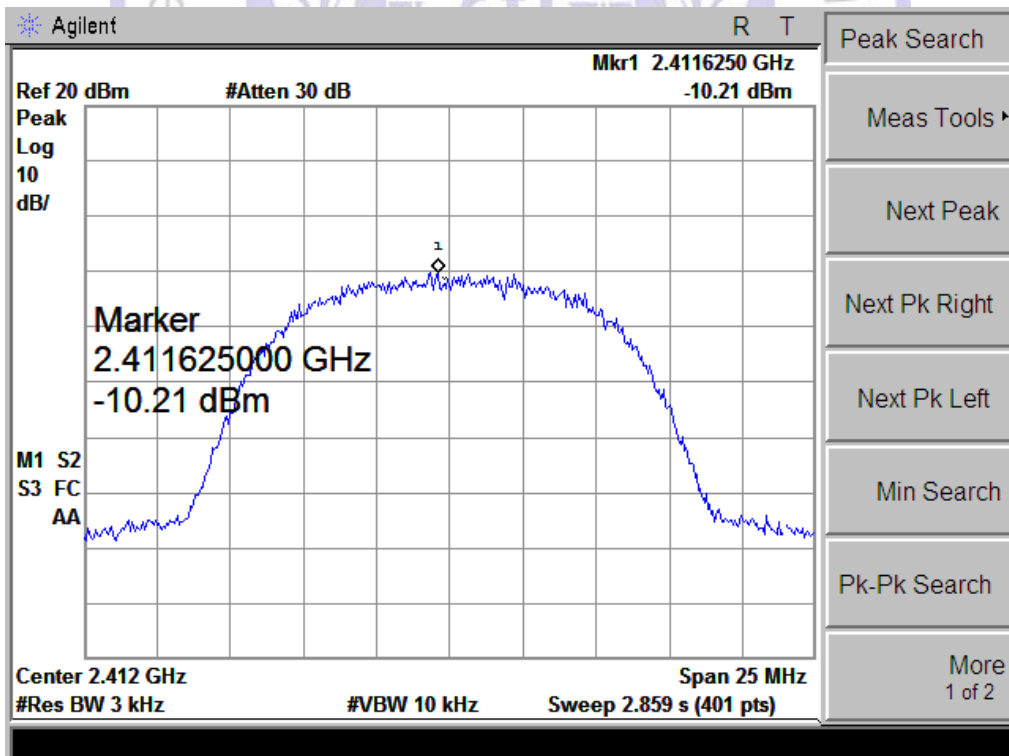

CH6 @ANT 1

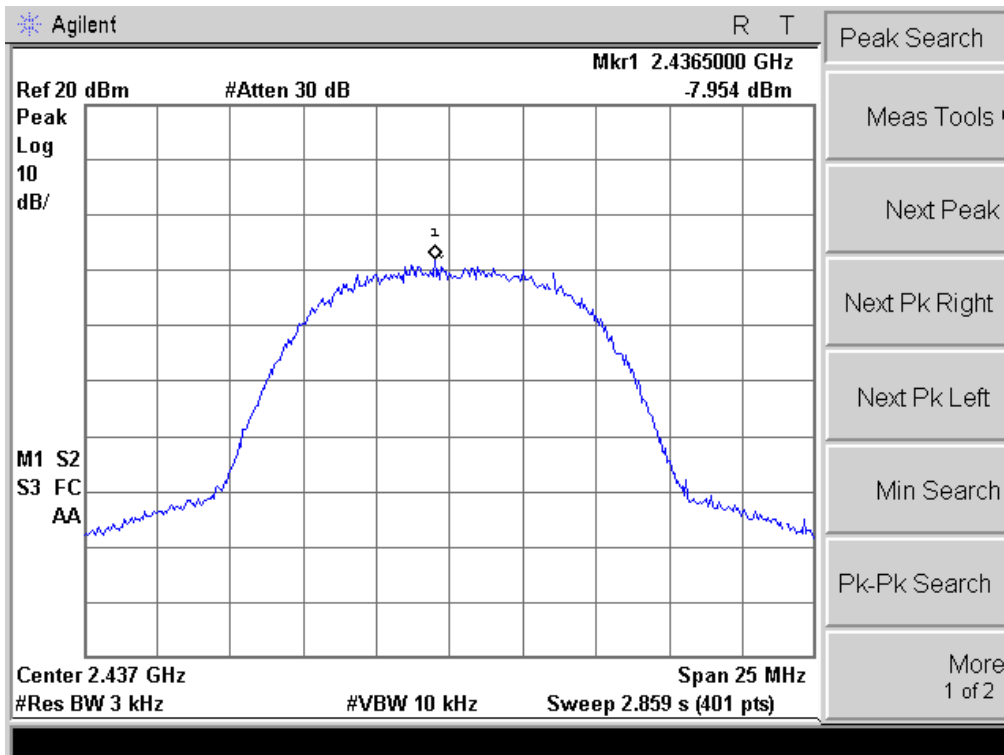

CH6 @ANT 2

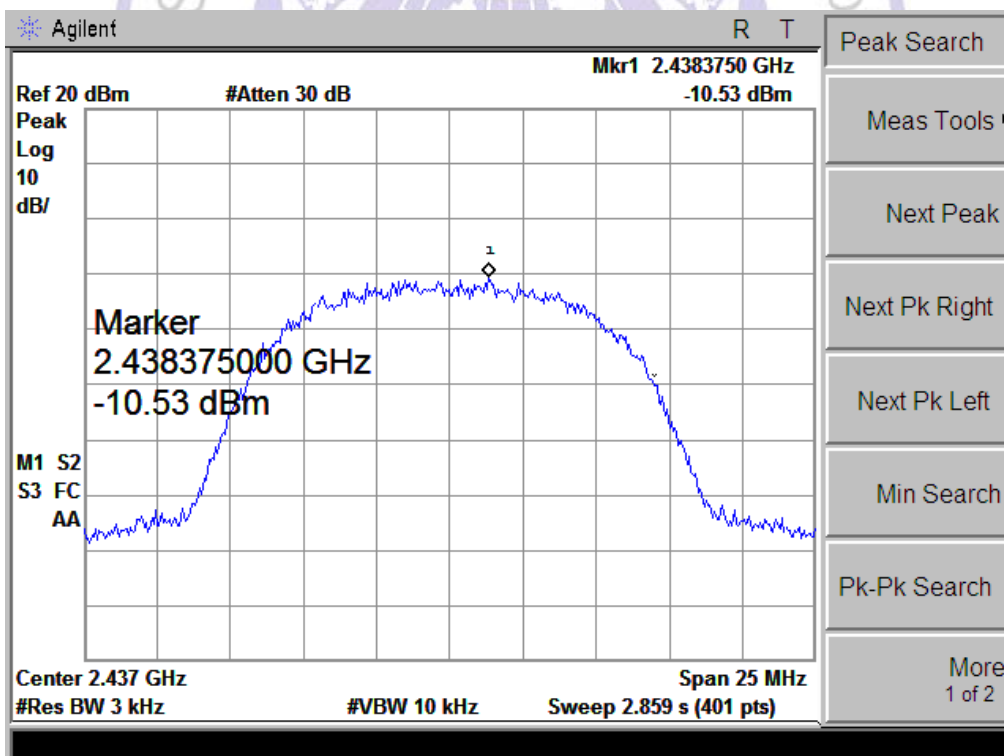

CH11 @ANT 1

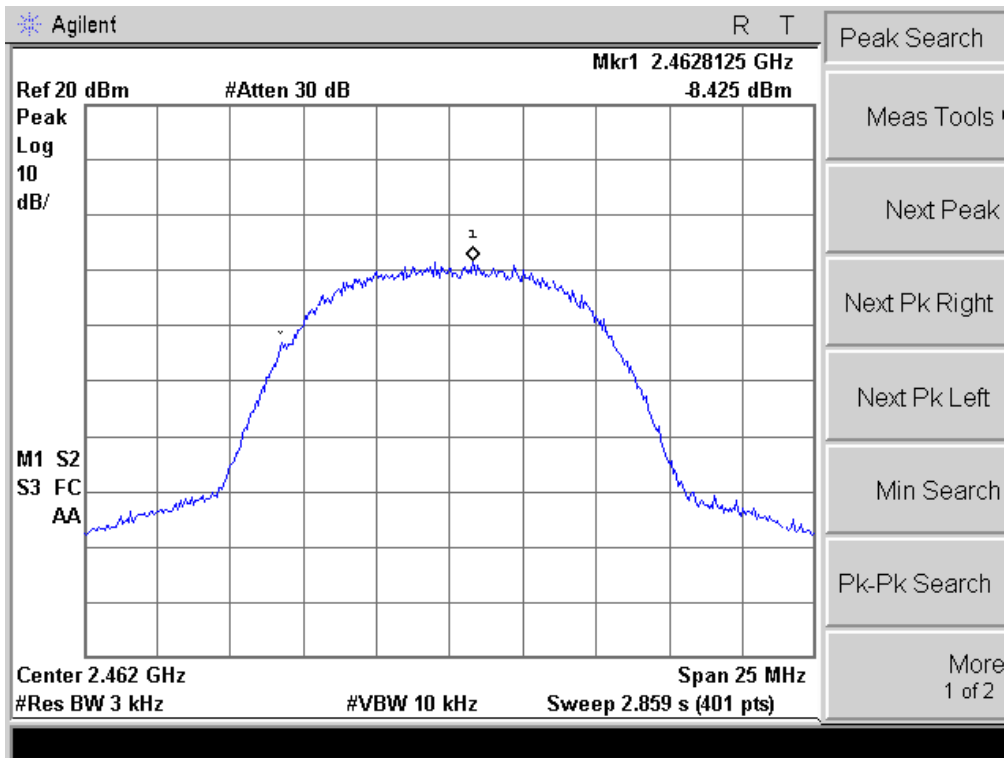

CH11 @ANT 2

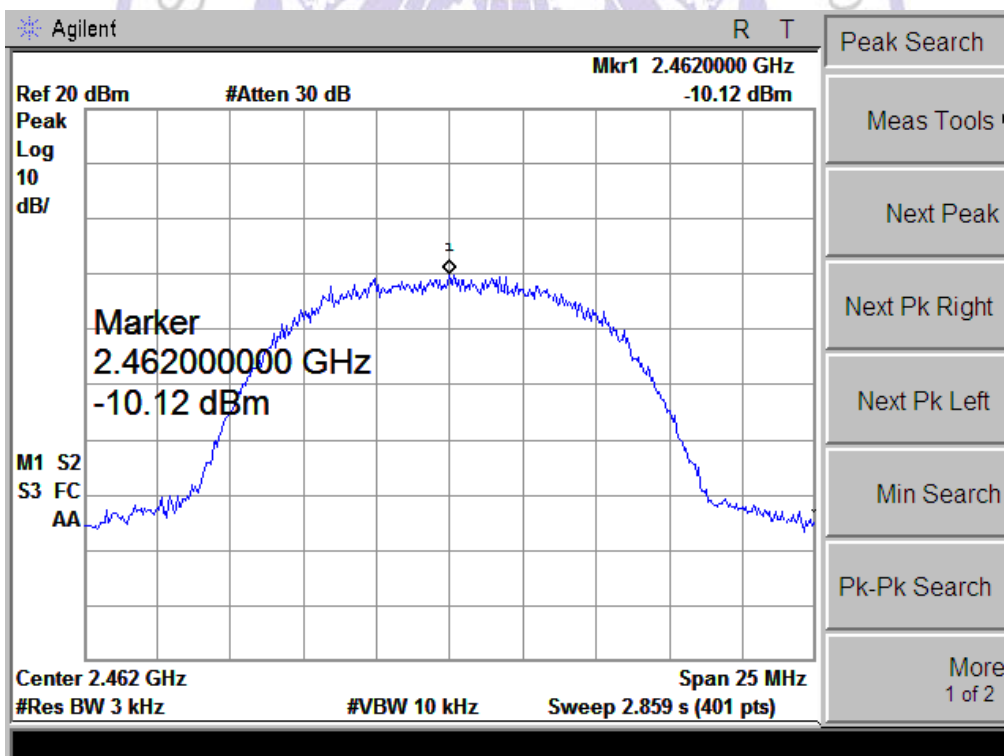

For 802.11g Mode:

CH1 @ANT 1

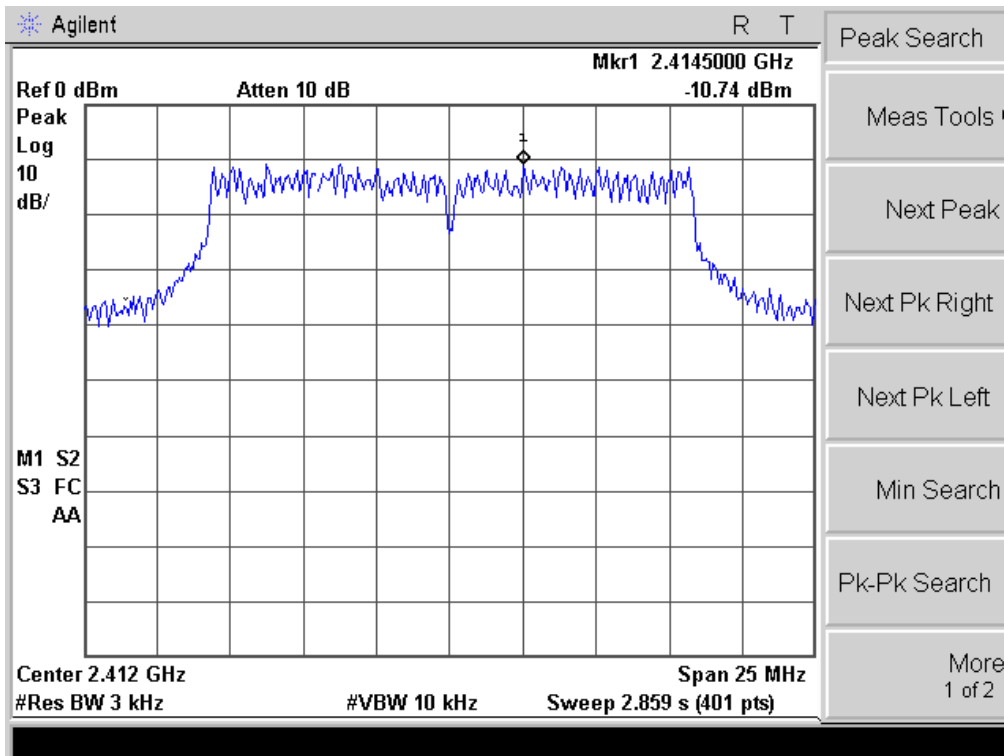

CH1 @ANT 2

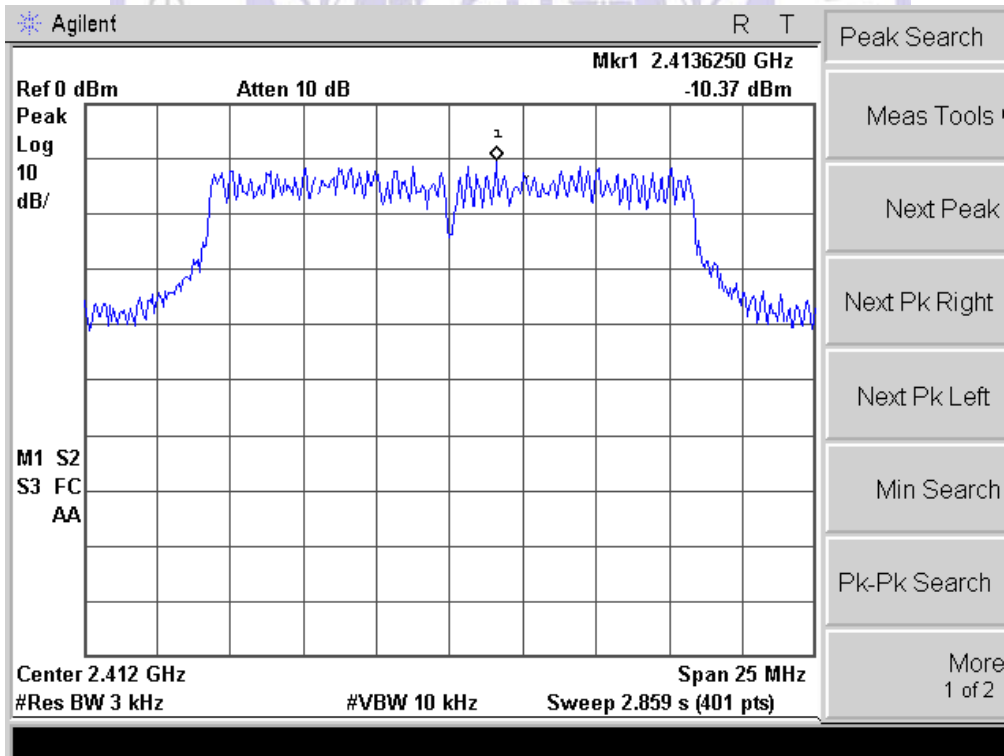

CH6 @ANT 1

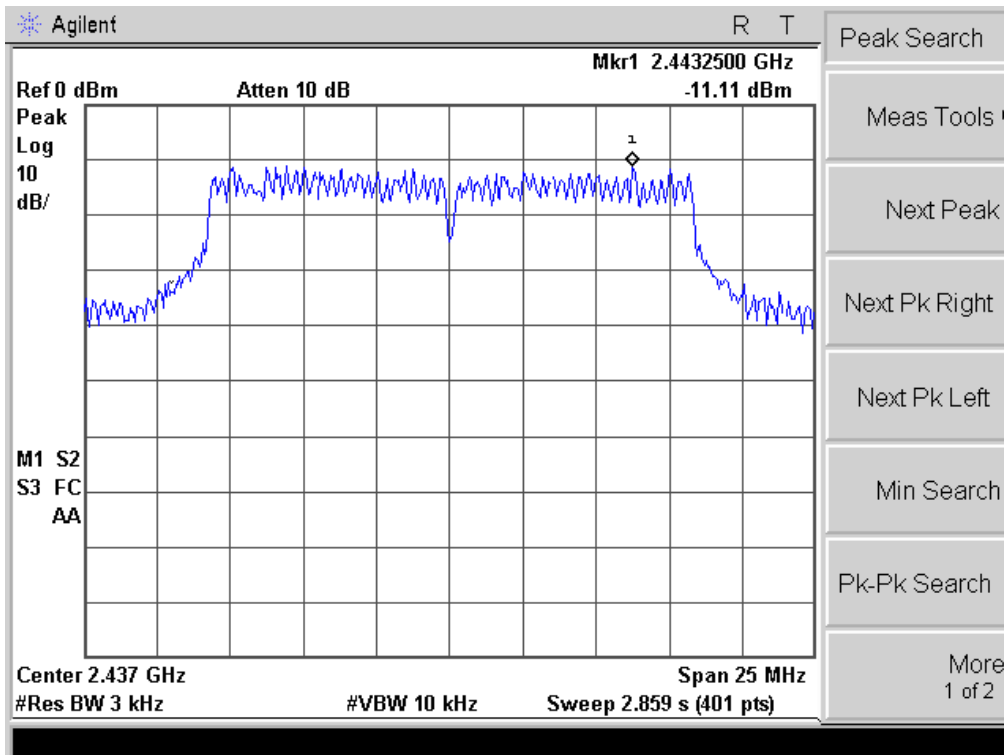

CH6 @ANT 2

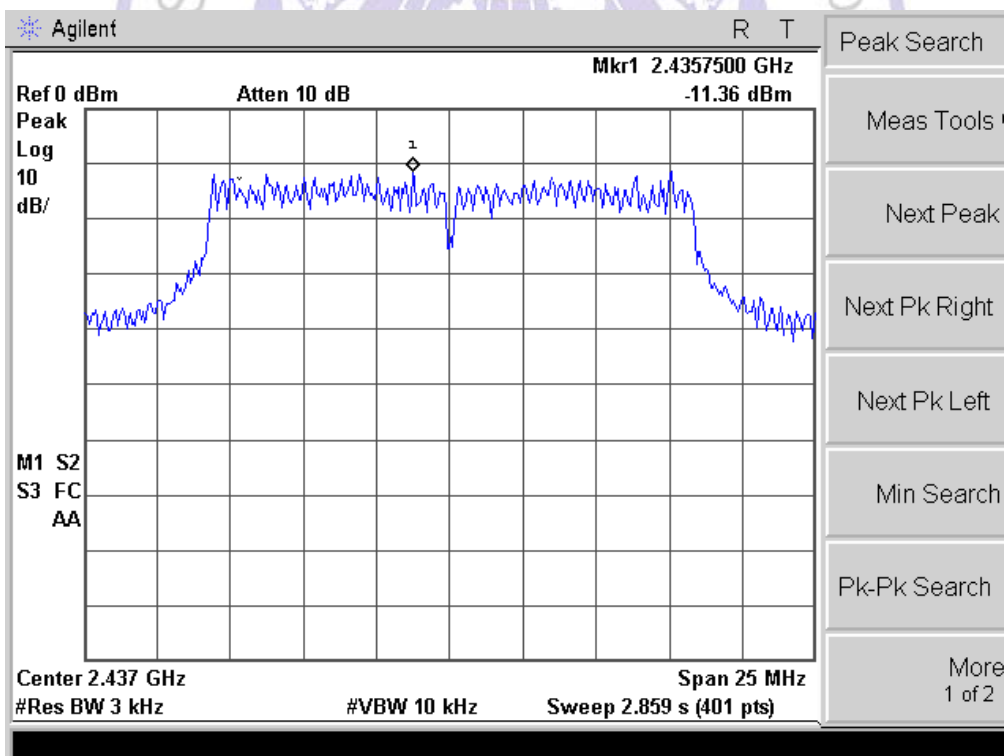

CH11 @ANT 1

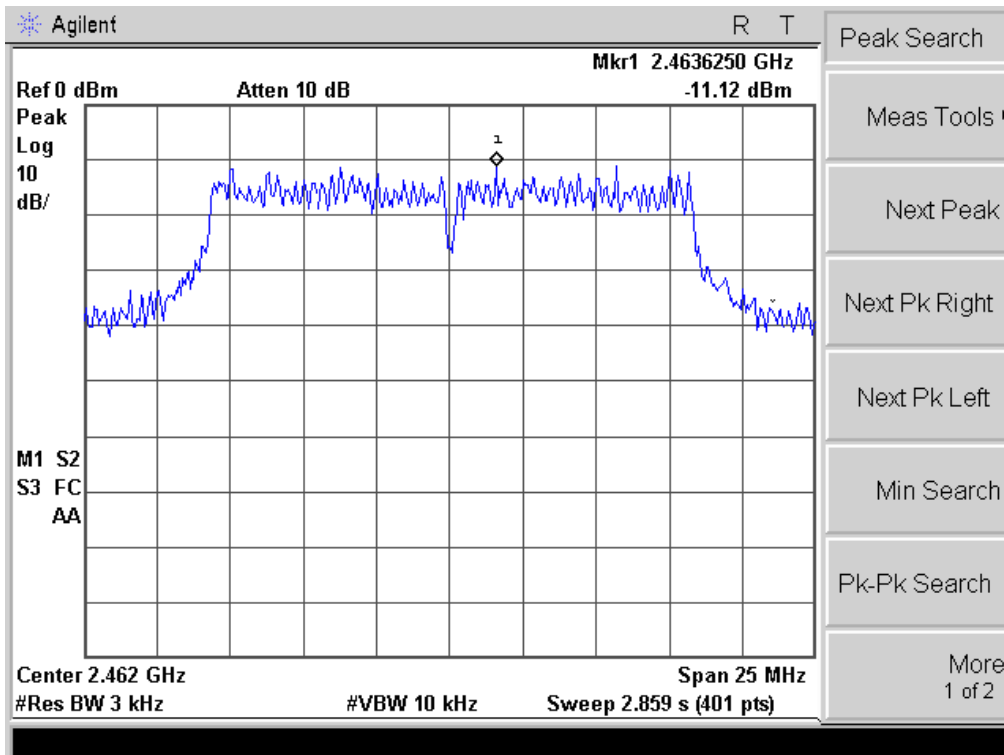

CH11 @ANT 2

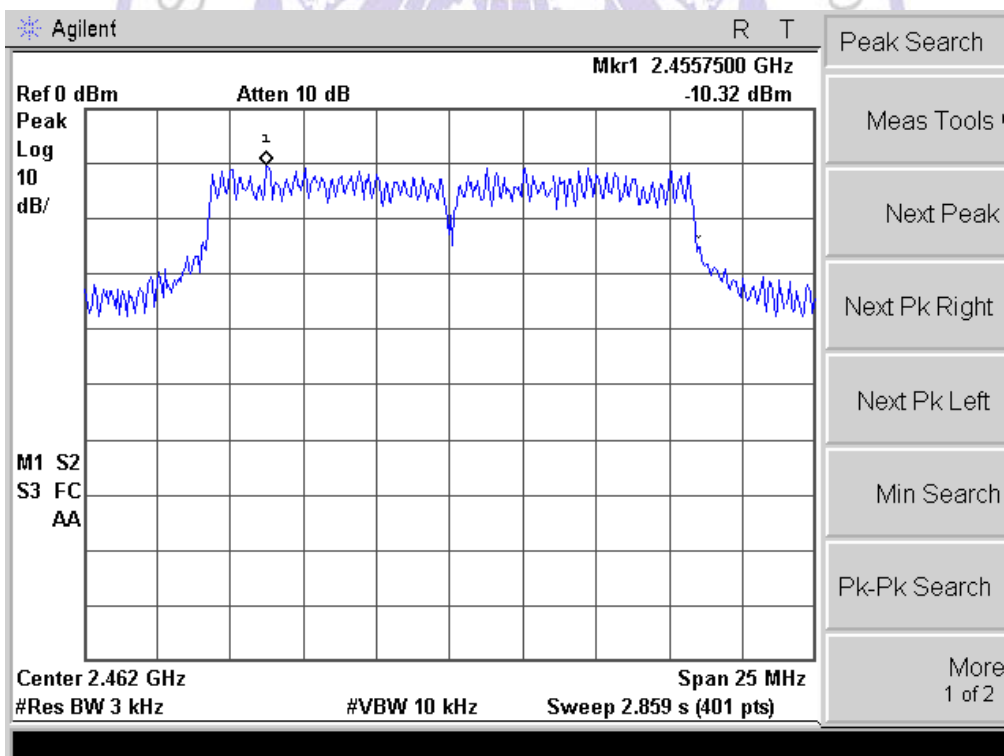

For 802.11n (20MHz) Mode:

CH1 @ANT 1

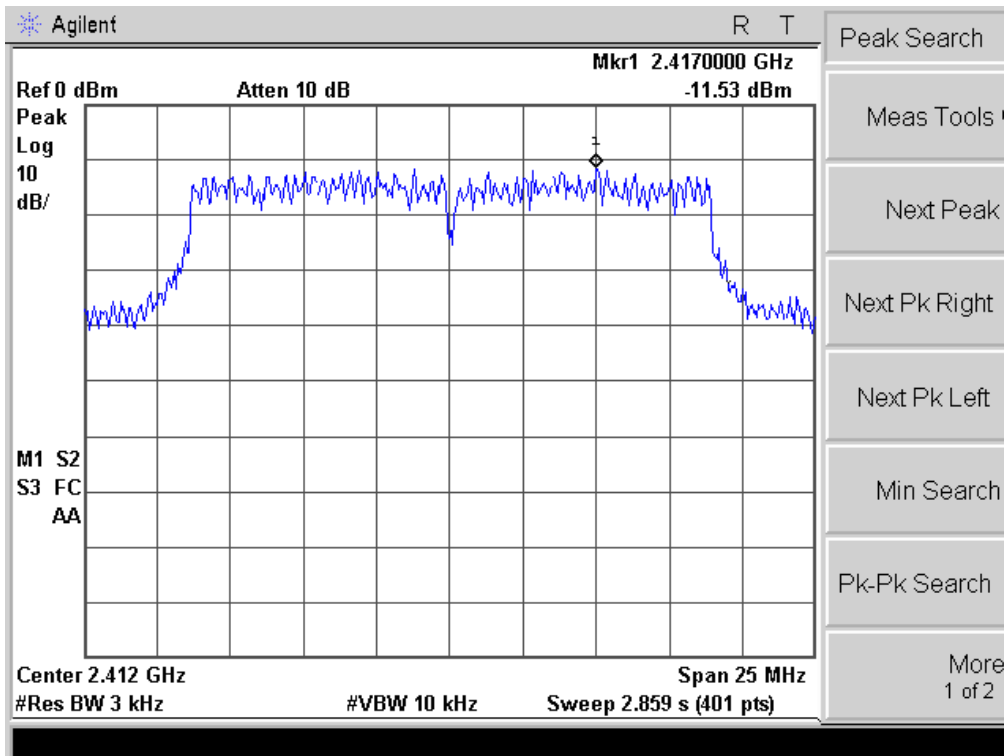

CH1 @ANT 2

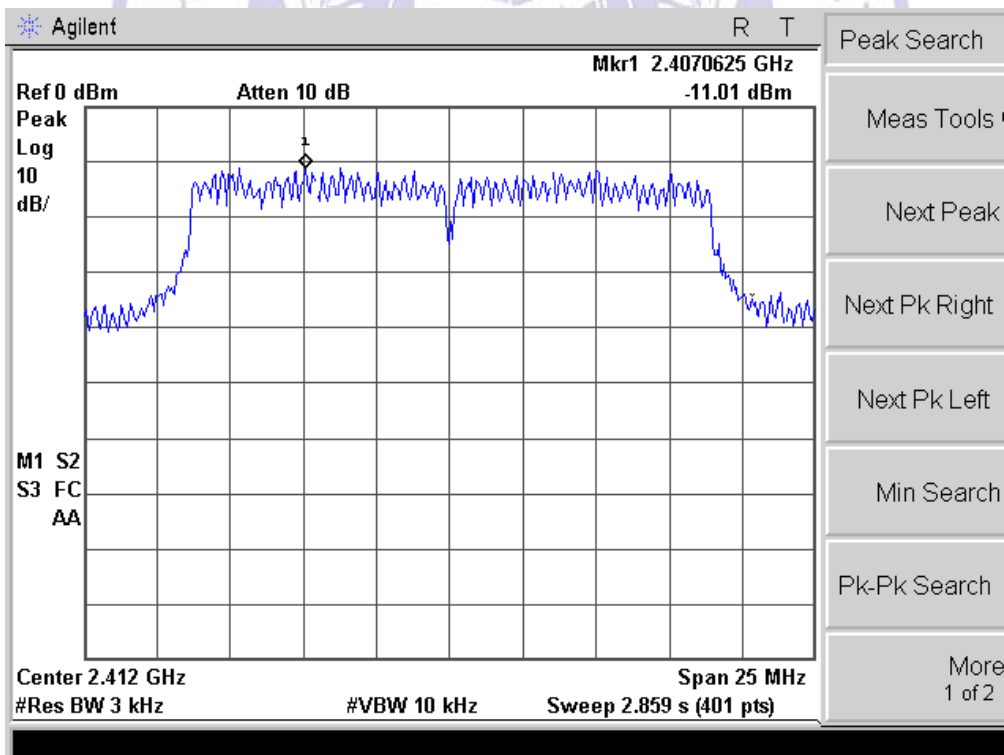

CH6 @ANT 1

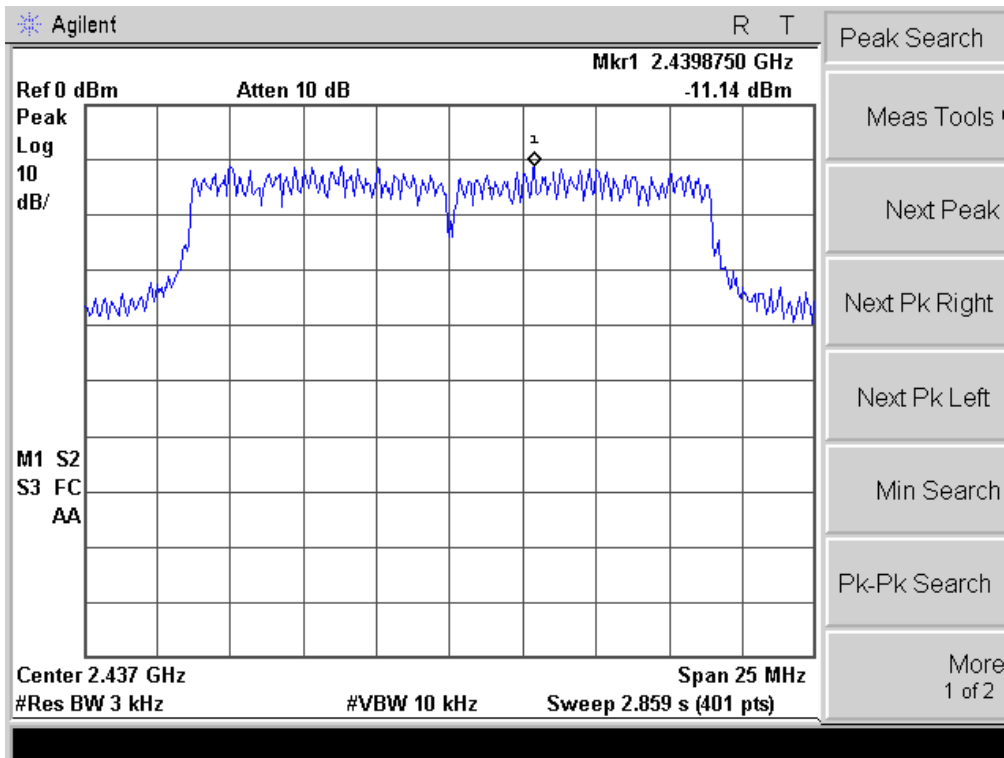

CH6 @ANT 2

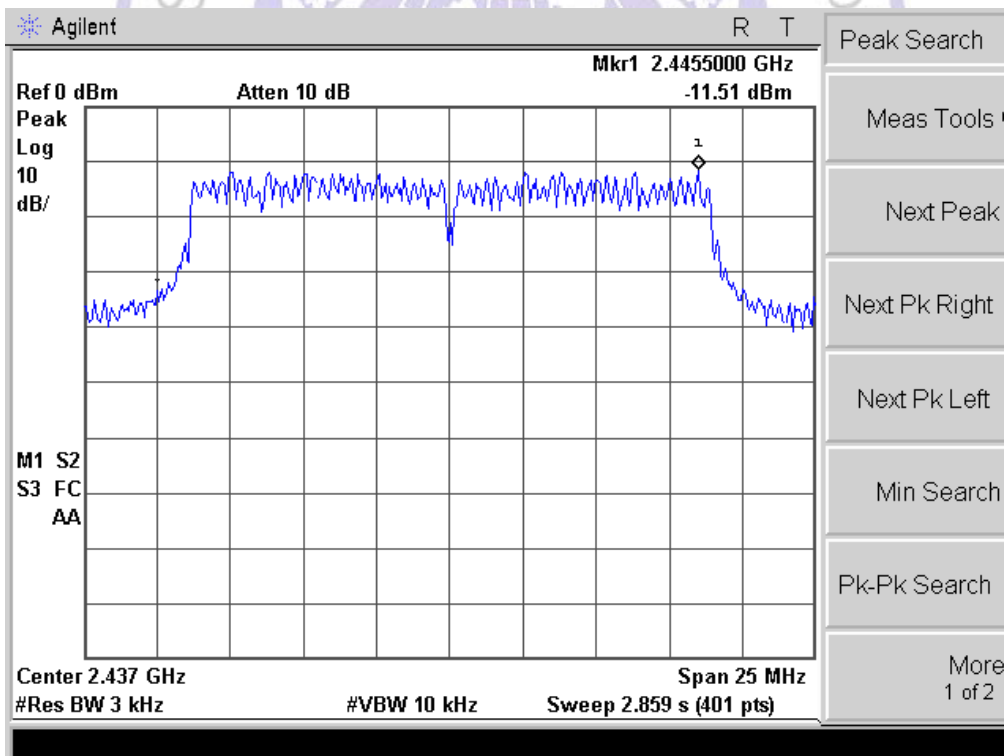

CH11 @ANT 1

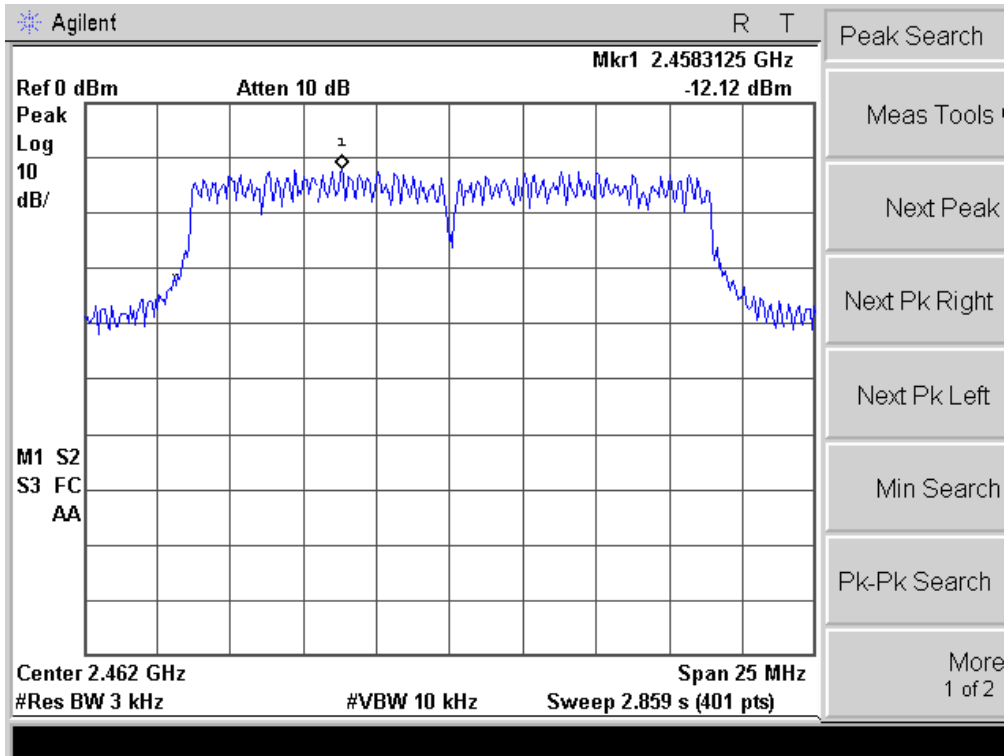

CH11 @ANT 2

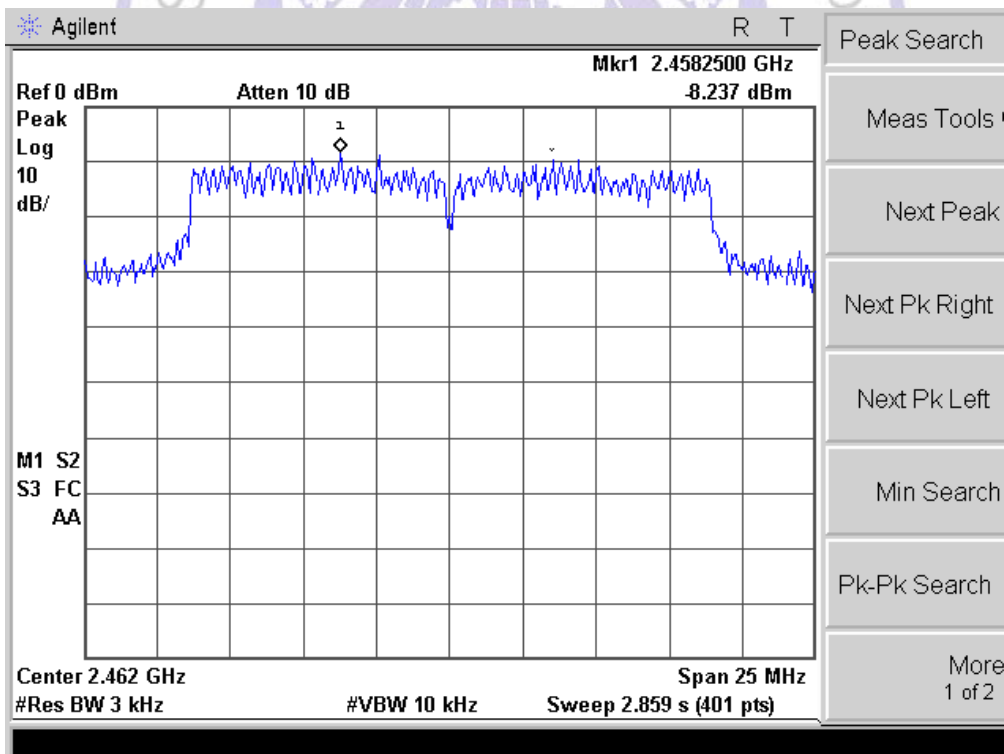

For 802.11n (40MHz) Mode:

CH3 @ANT 1

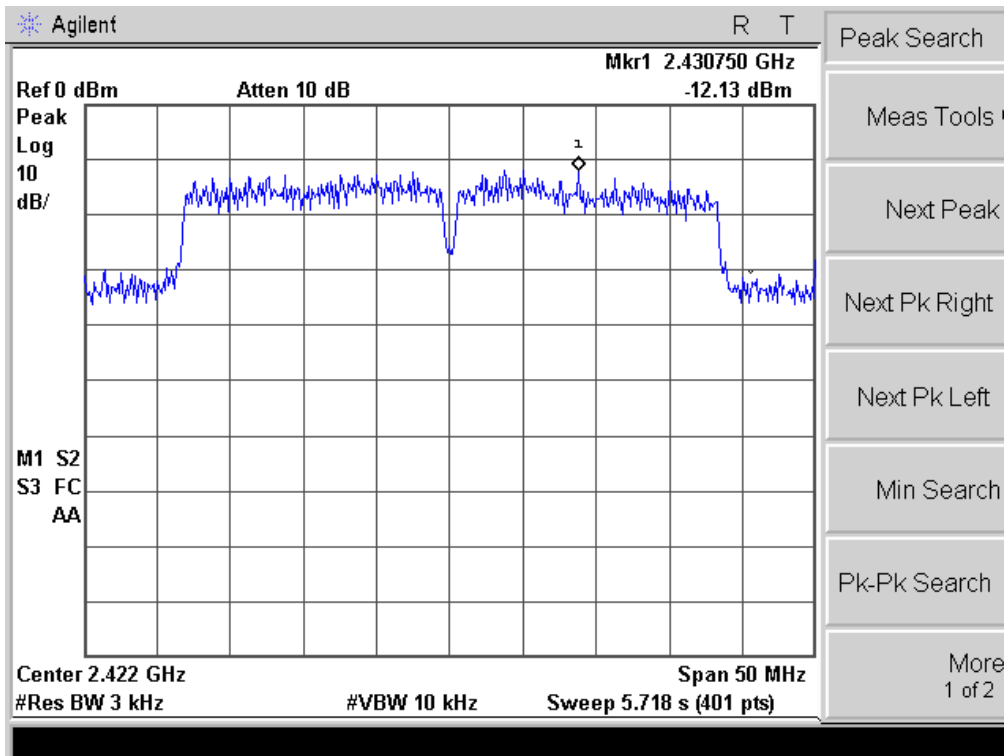

CH3 @ANT 2

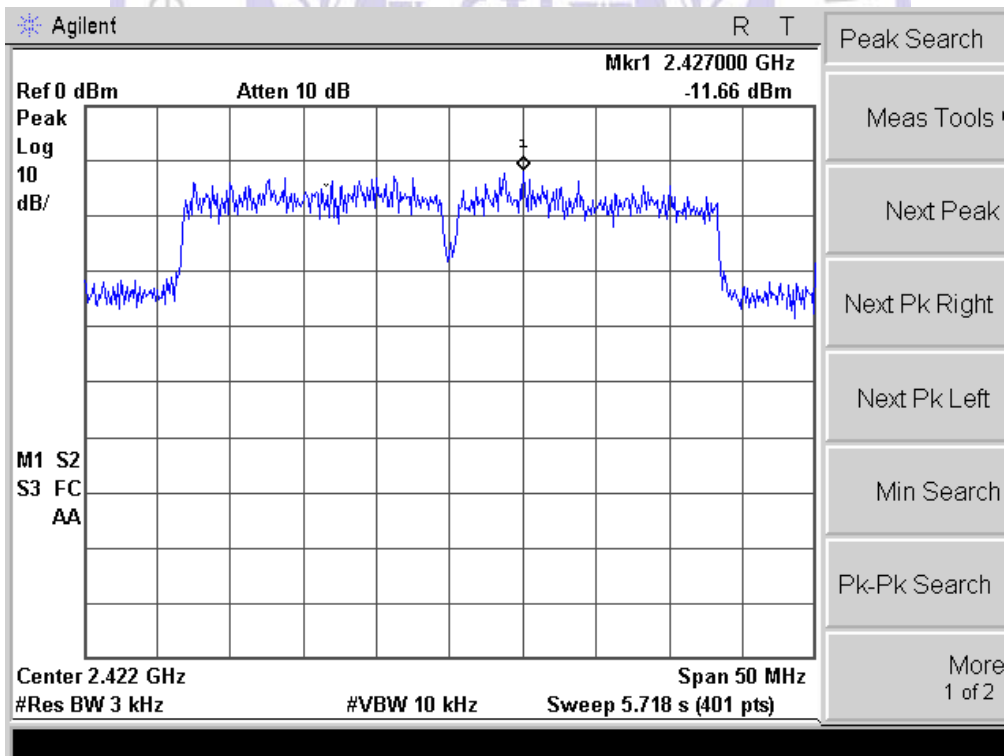

CH6 @ANT 1

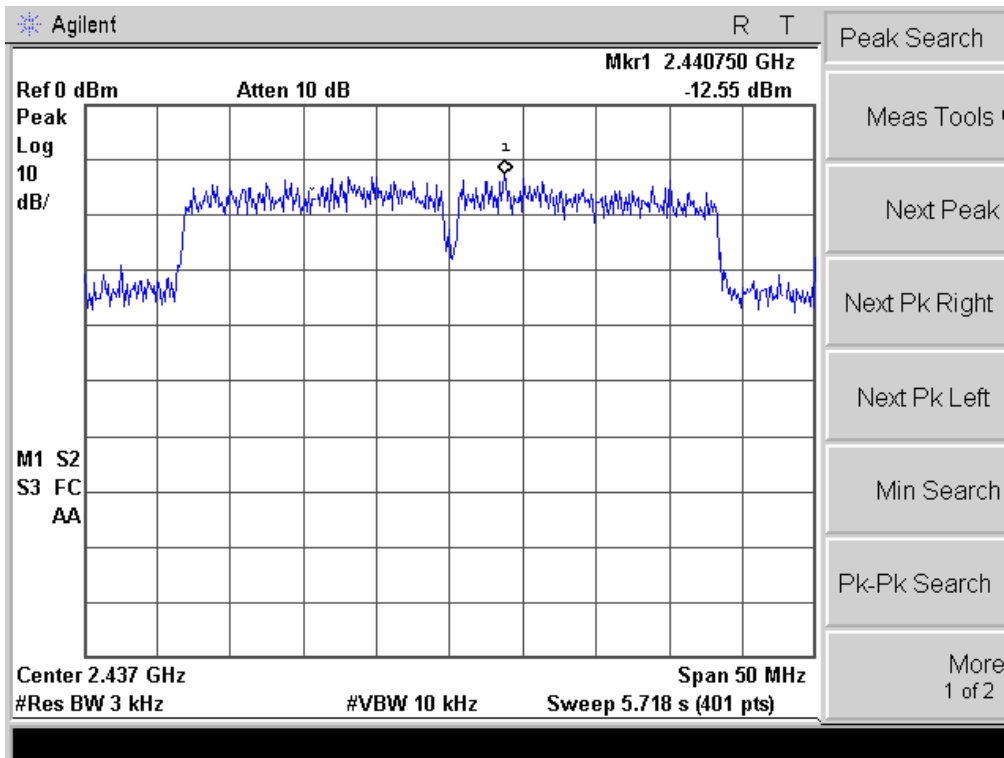

CH6 @ANT 2

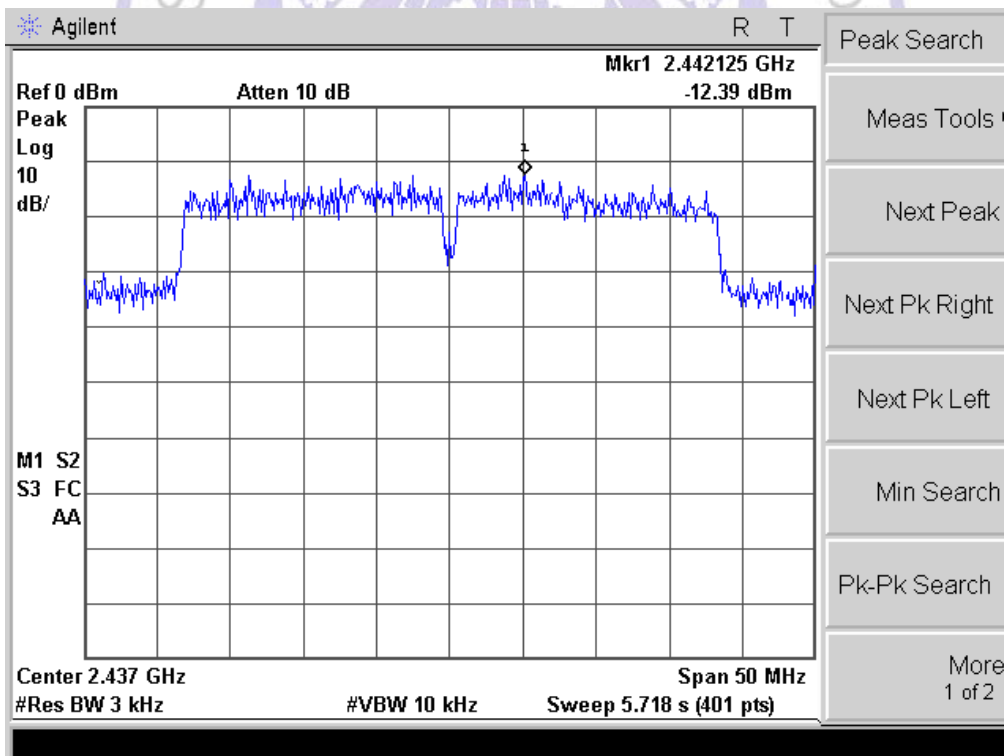

CH9 @ANT 1

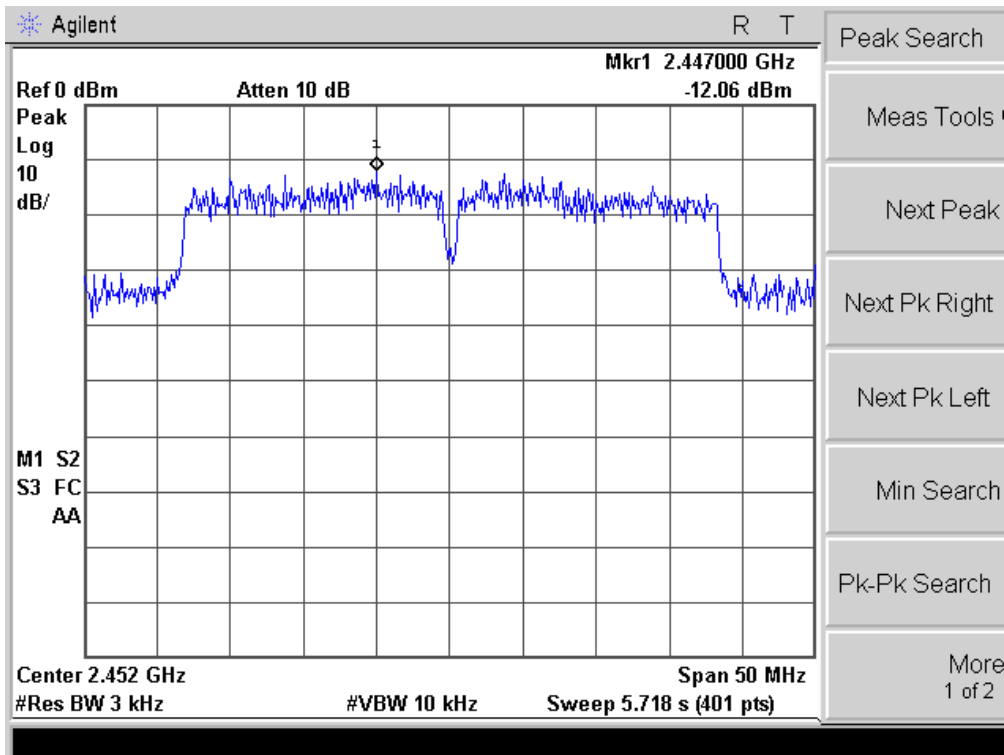

CH9 @ANT 2

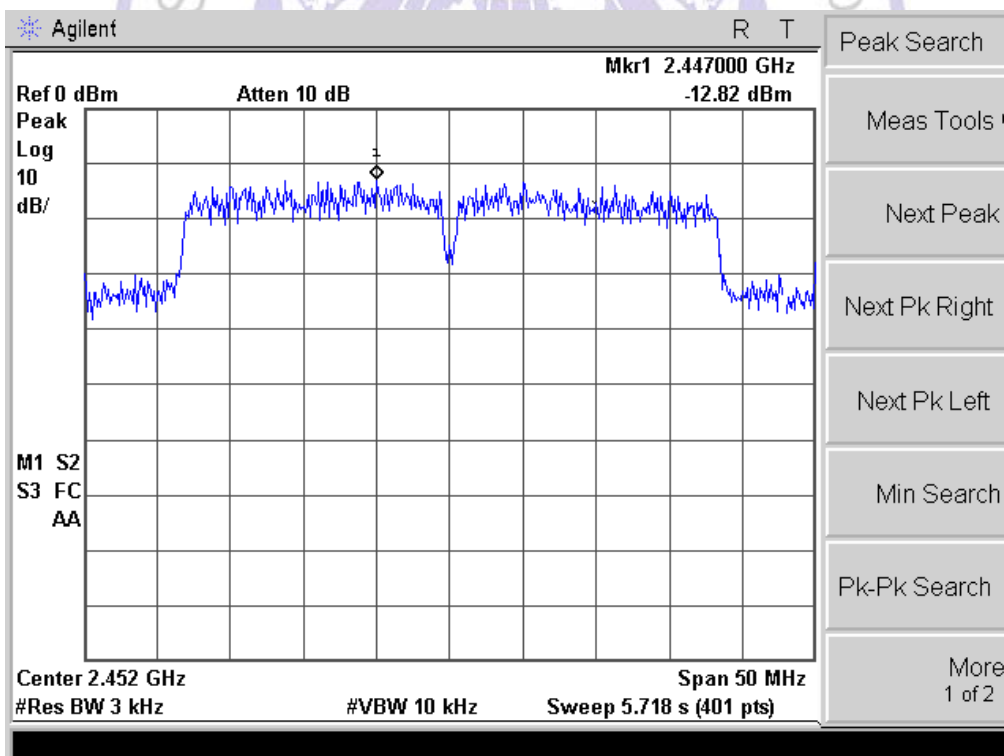

4.7. Spurious RF Conducted Emission

TEST CONFIGURATION

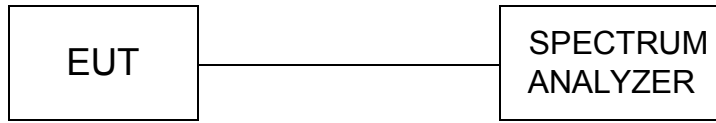

TEST PROCEDURE

The EUT was tested according to KDB558074 D01 v03r02 for compliance to FCC 47CFR 15.247 requirements.

The Spurious RF conducted emissions compliance of RF radiated emission should be measured by following the guidance in ANSI C63.10-2009 with respect to maximizing the emission by rotating the EUT, measuring the emission while the EUT is situated in three orthogonal planes (if appropriate), adjusting the measurement antenna height and polarization etc. Set RBW=100kHz and VBM= 300kHz to measure the peak field strength , and measure frequency range from 30MHz to 26.5GHz.

LIMIT

In any 100 kHz bandwidth outside the frequency band in which the spread spectrum or digitally modulated intentional radiator is operating, the radio frequency power that is produced by the intentional radiator shall be at least 20 dB below that in the 100 kHz bandwidth within the band that contains the highest level of the desired power, based on either an RF conducted or a radiated measurement, provided the transmitter demonstrates compliance with the peak conducted power limits.

TEST RESULTS

Photos of Spurious RF Conducted Emission Measurement

For 802.11b Mode:

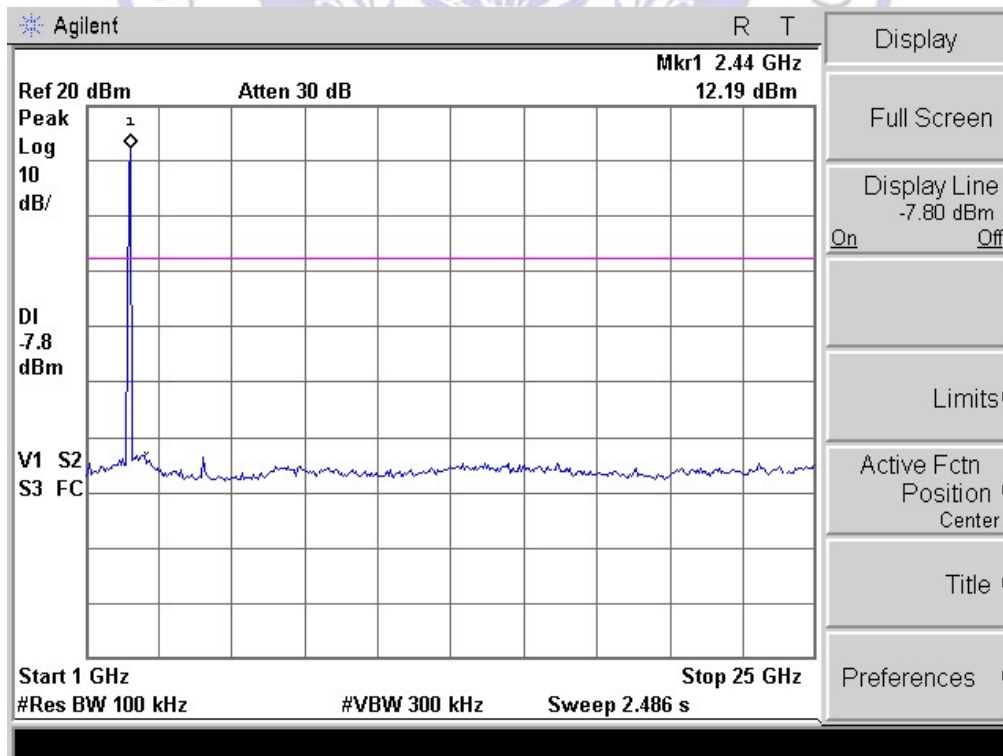

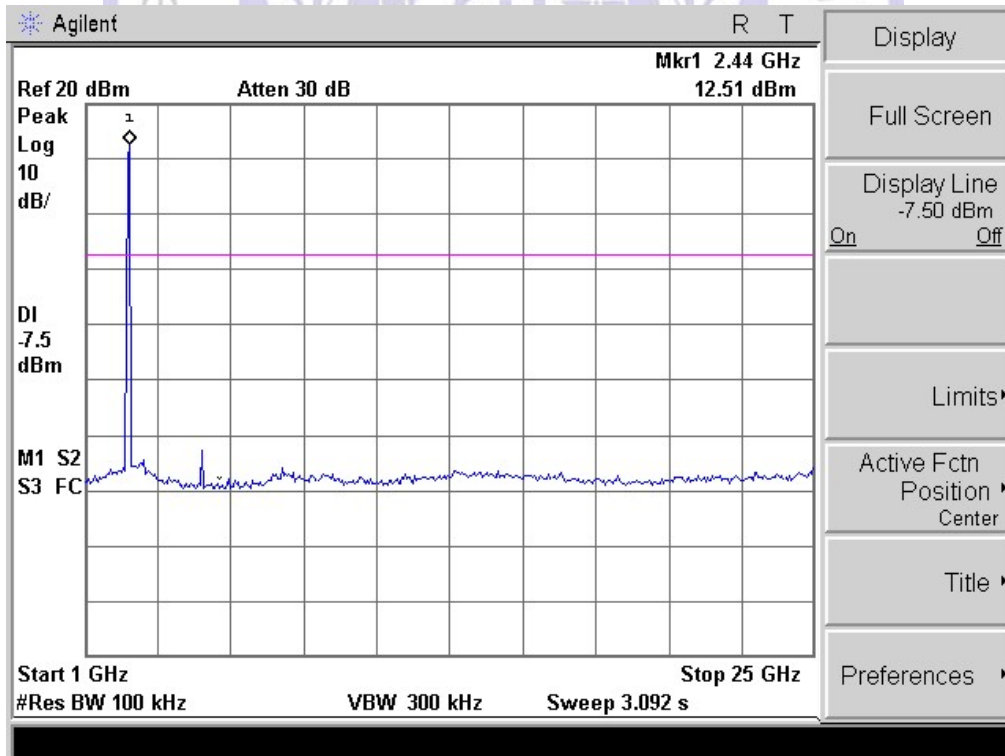
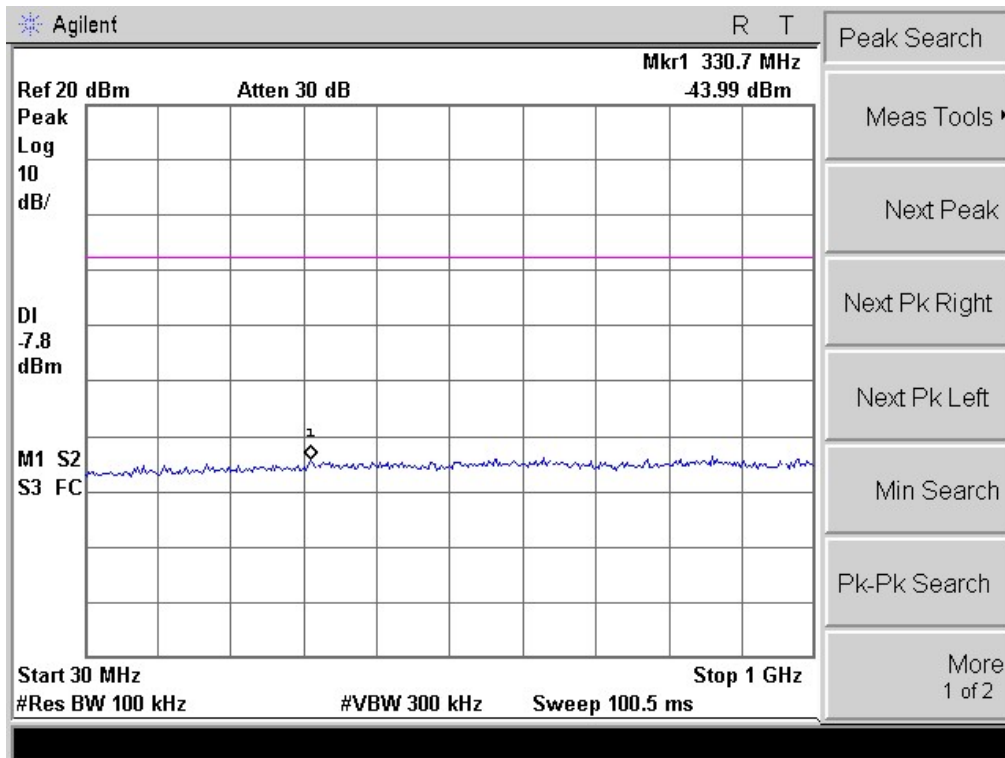

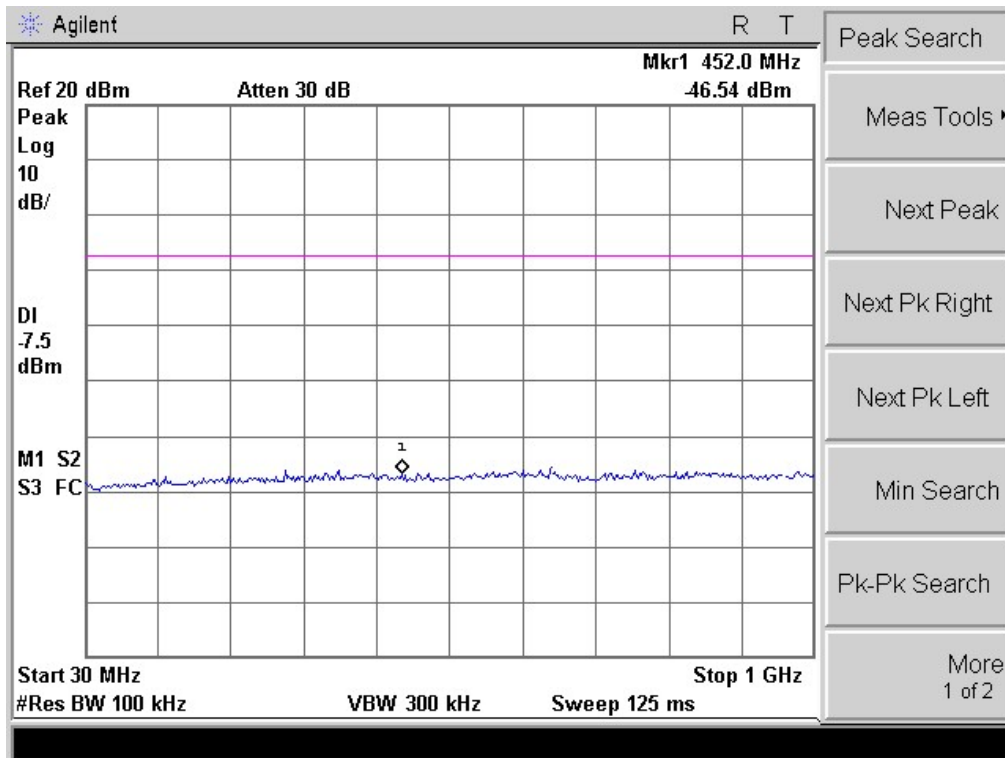

CH6 @ANT 1

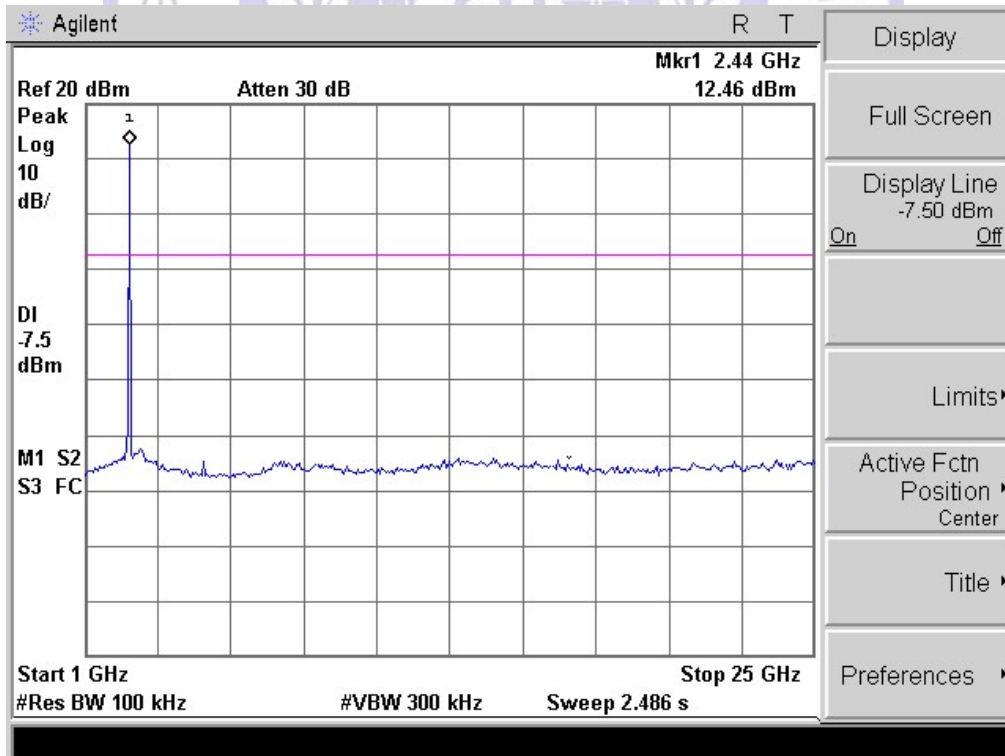

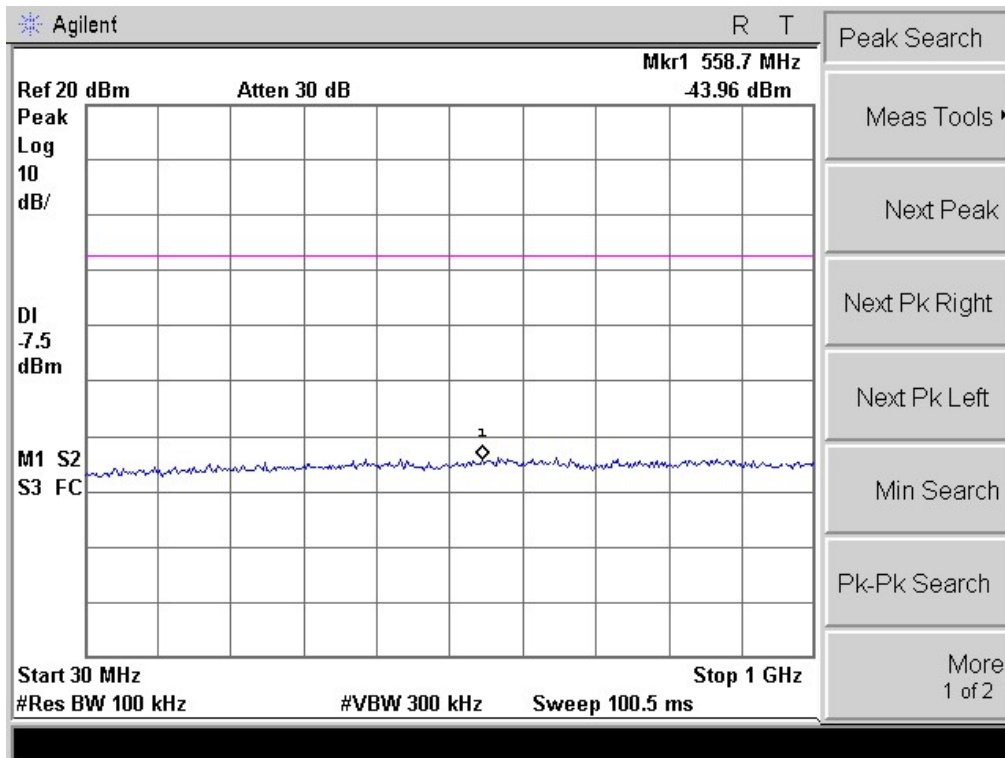

CH6 @ANT 2

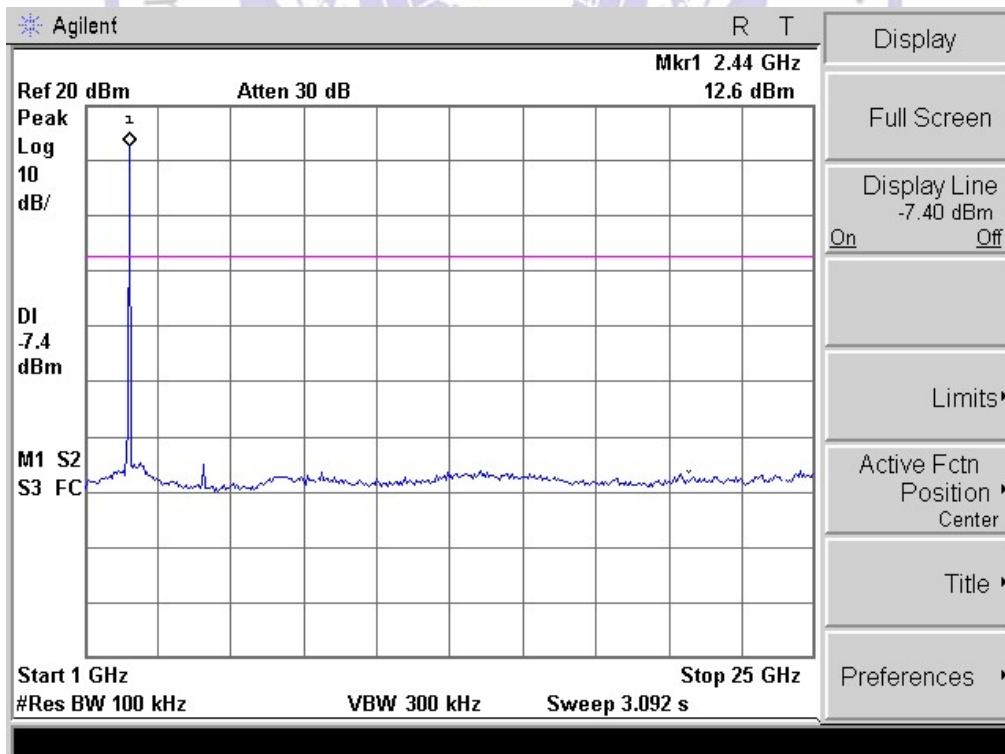

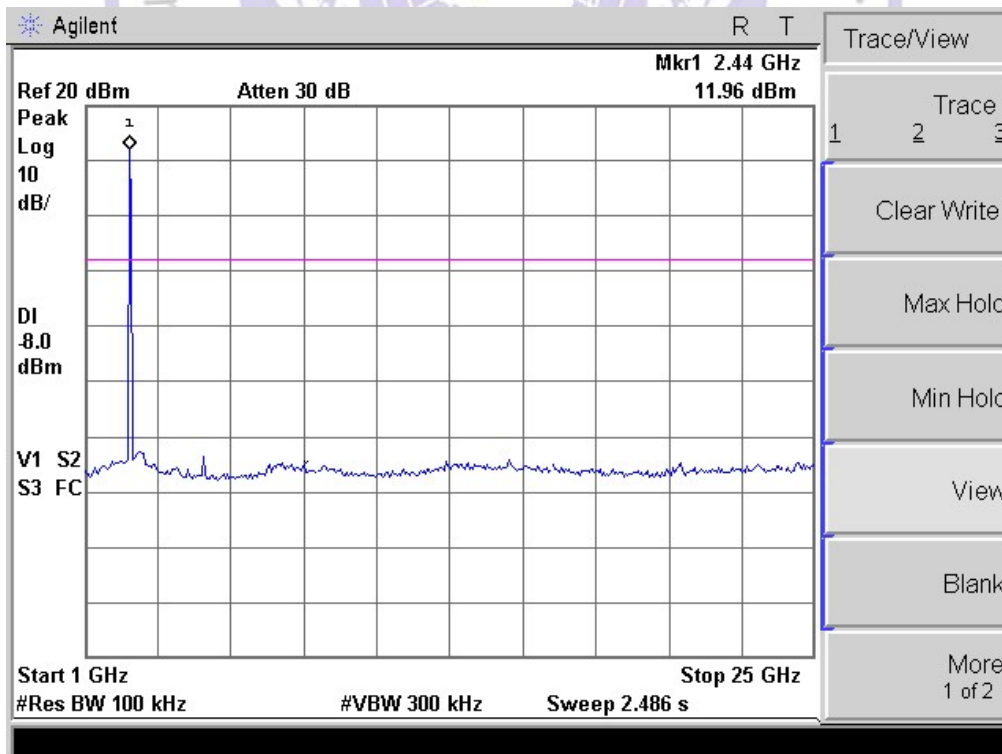
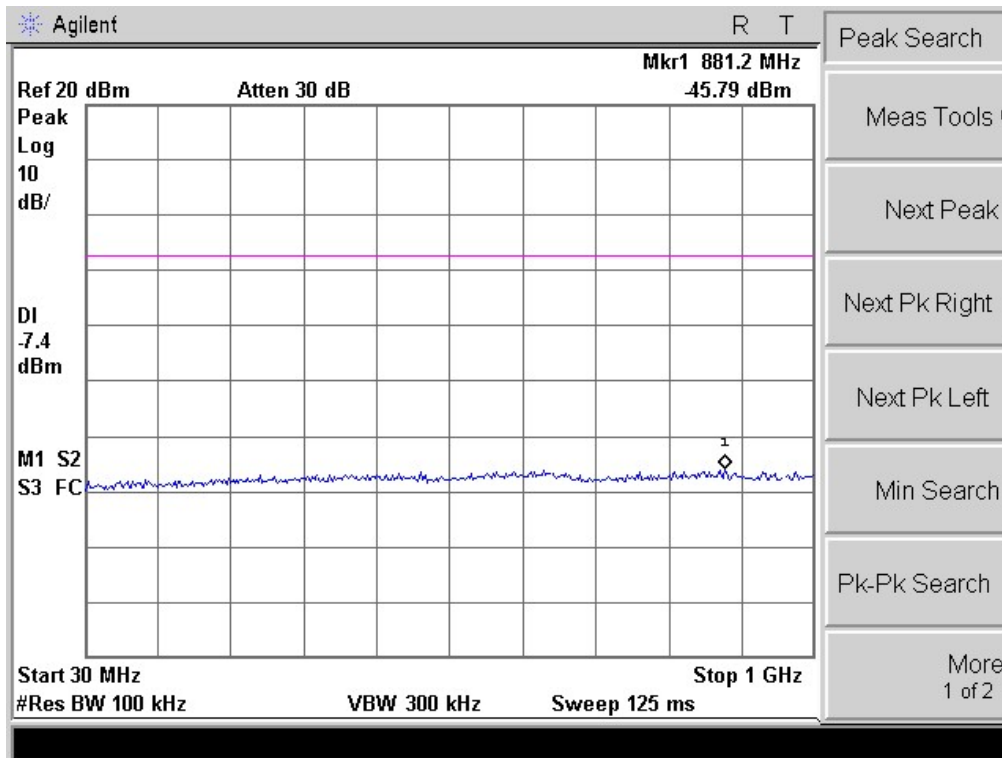

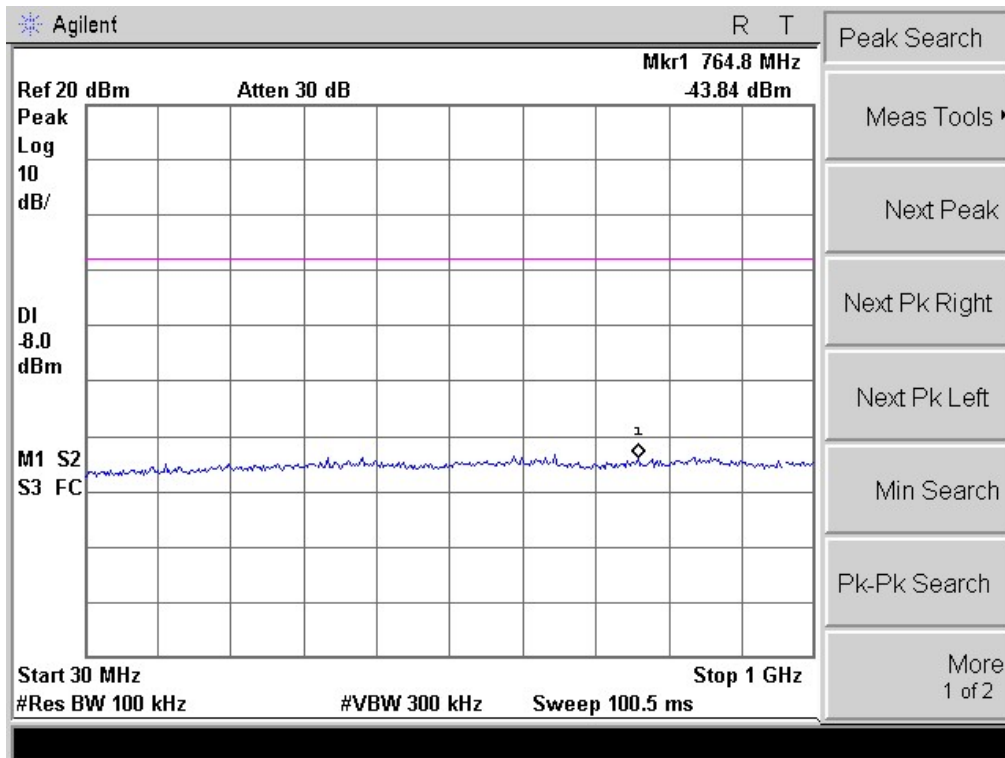

CH11 @ANT 2

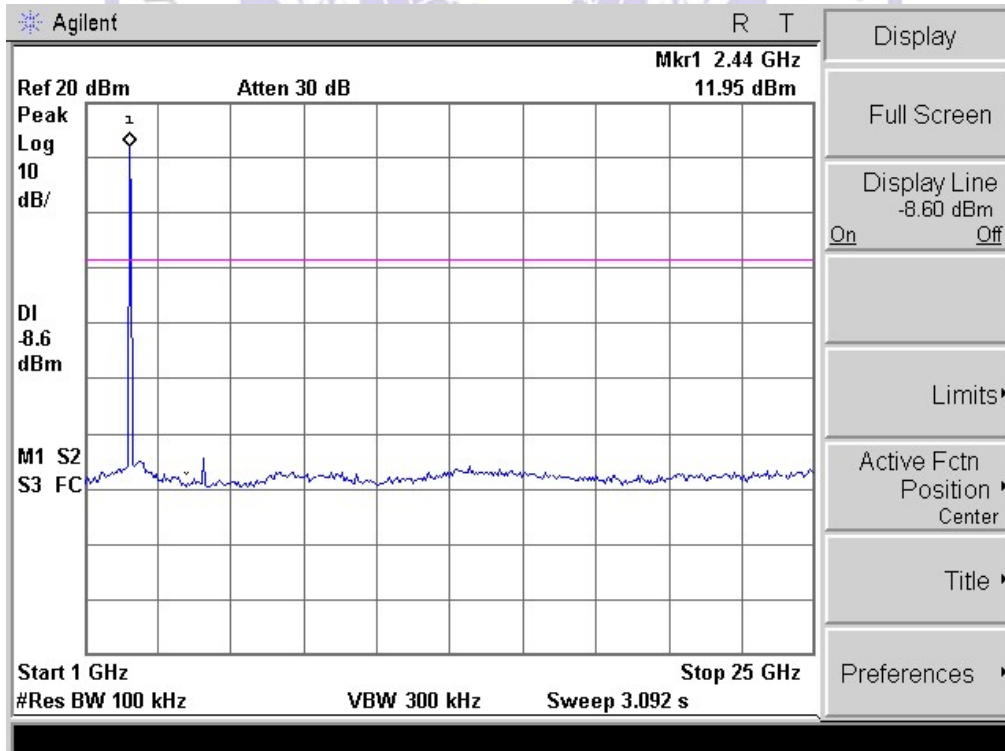

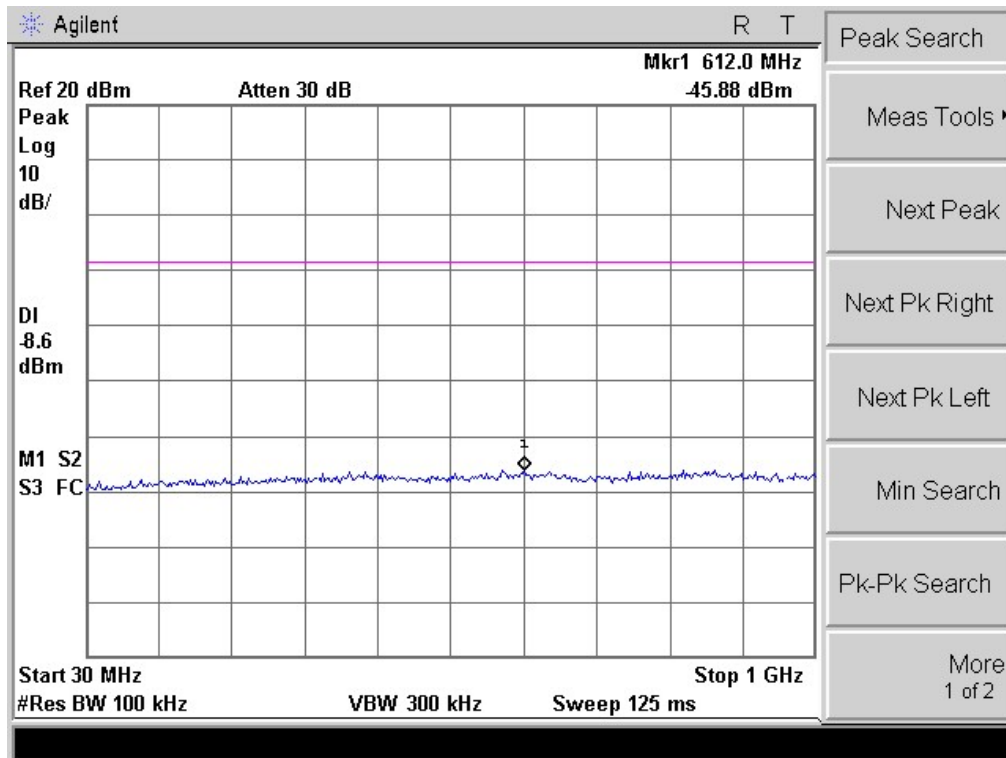

For 802.11g Mode:

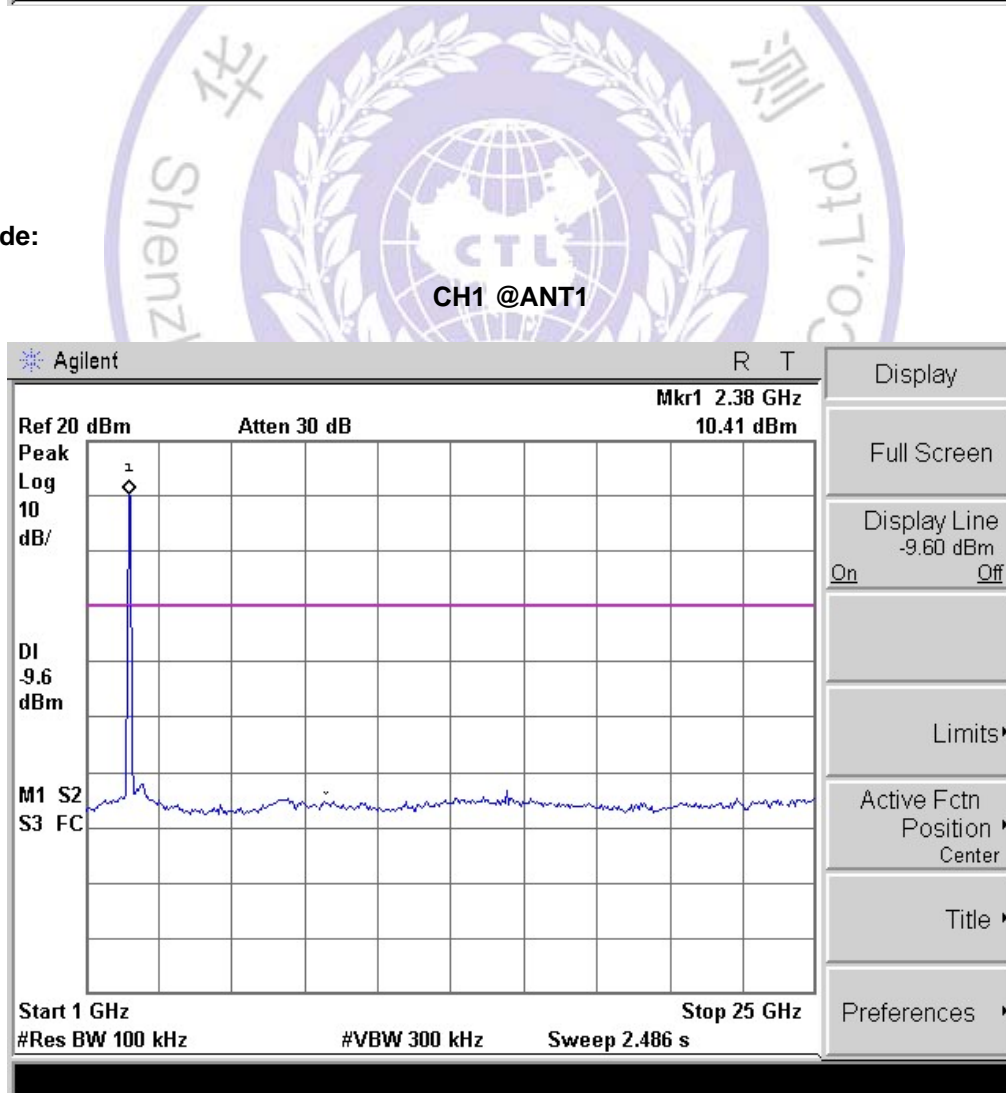

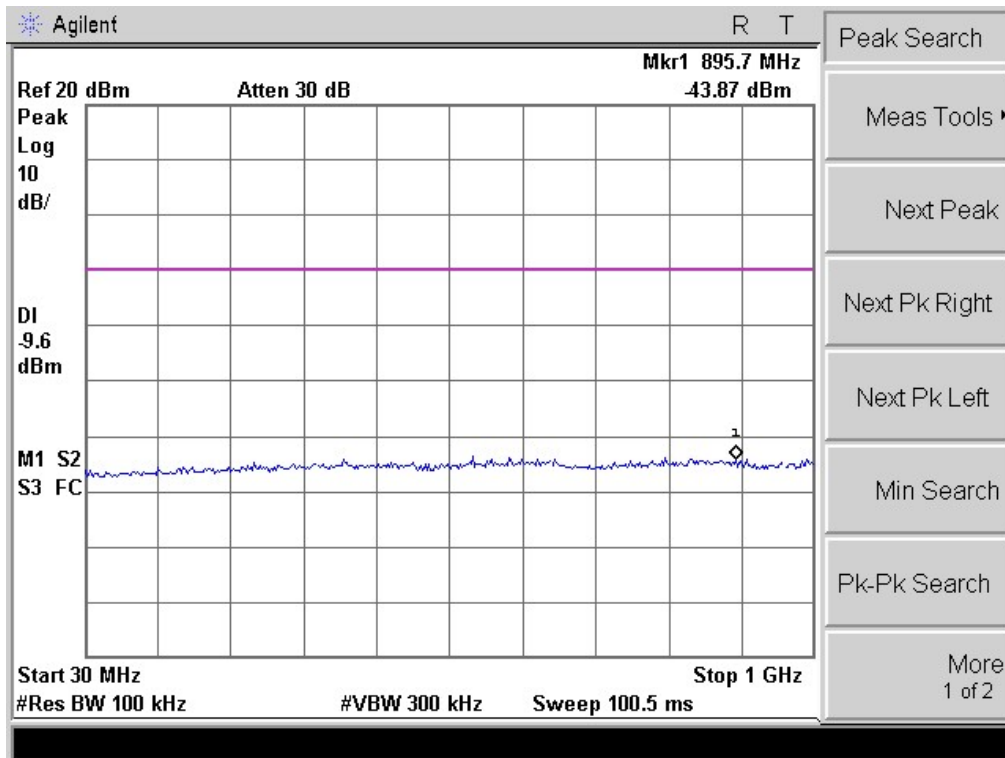

CH1 @ANT 2

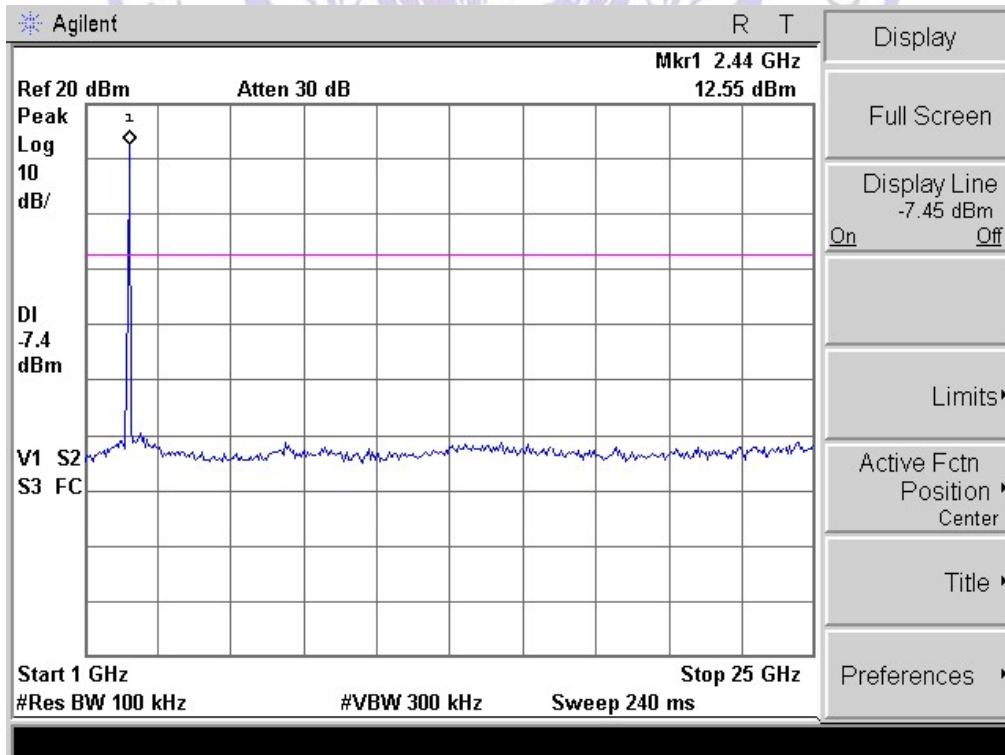

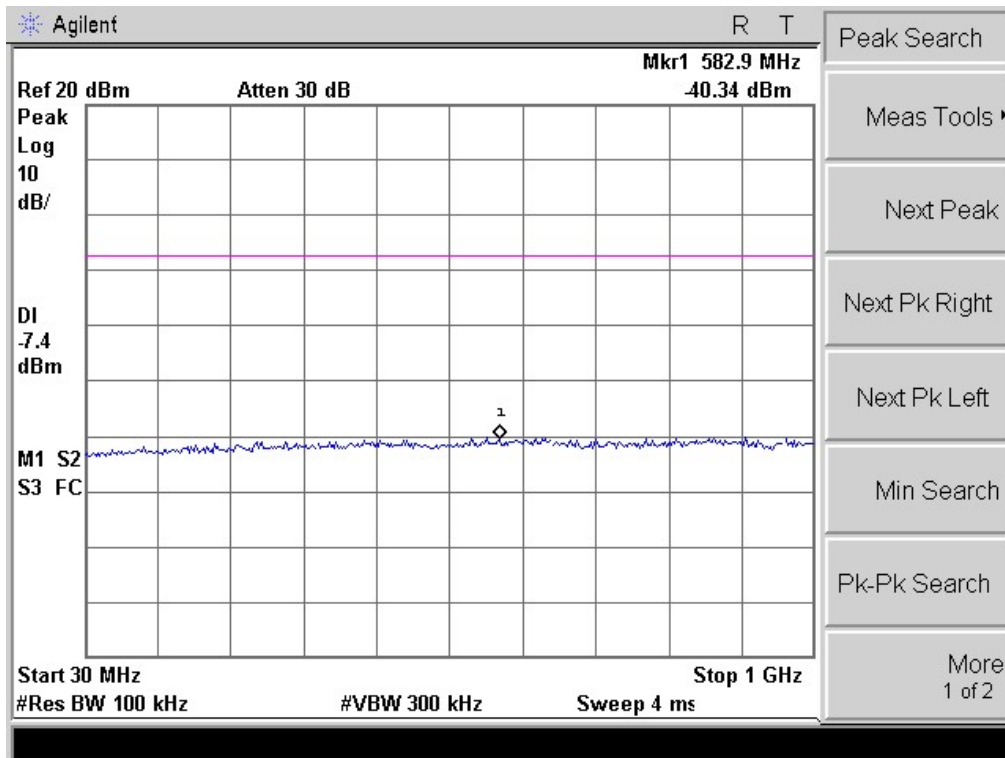

CH6 @ANT 1

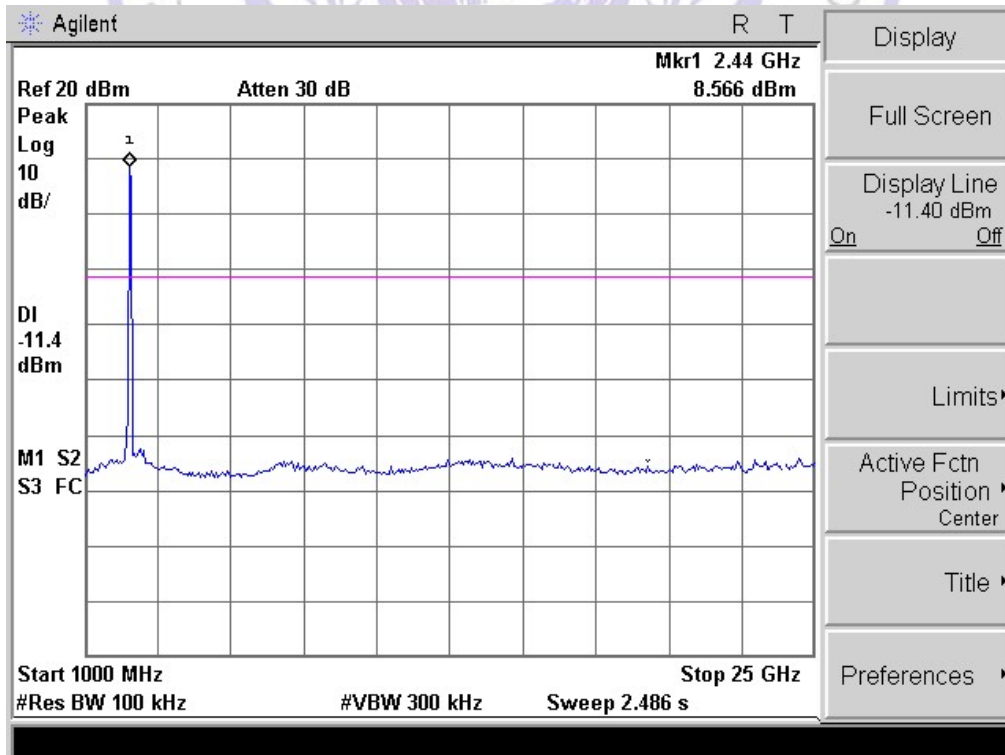

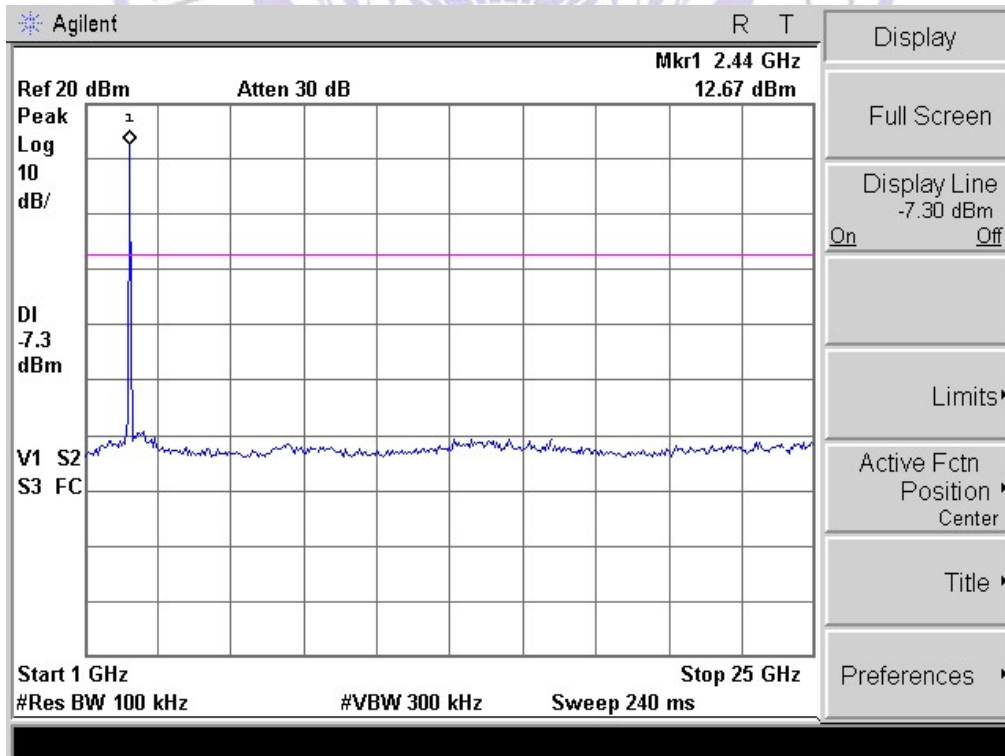
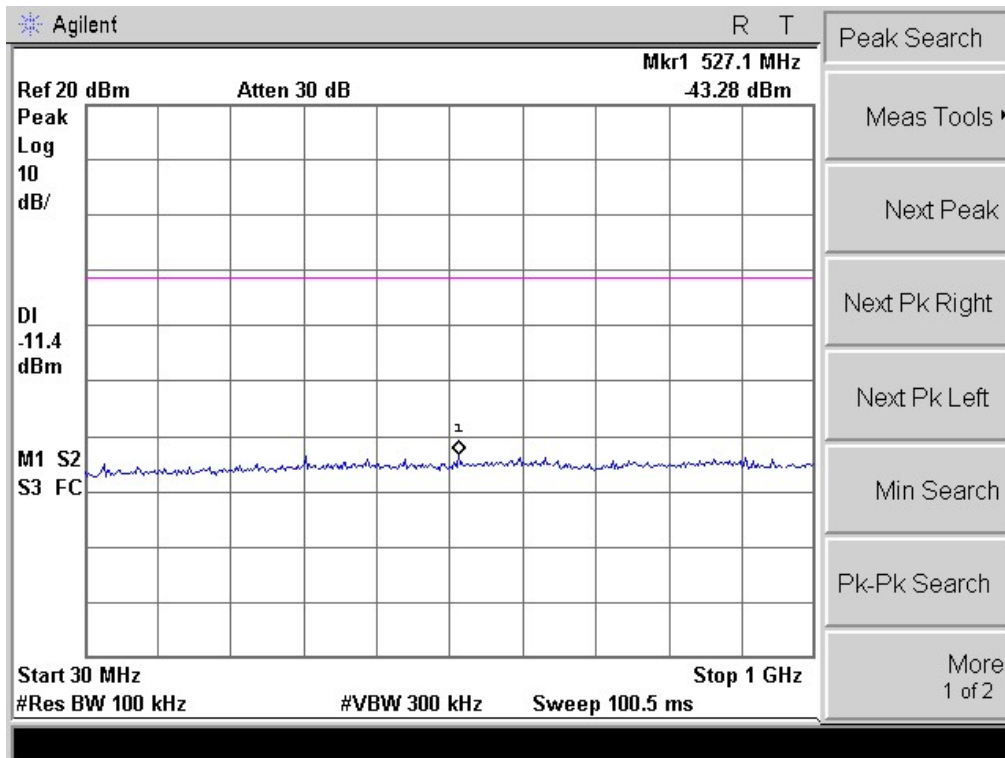

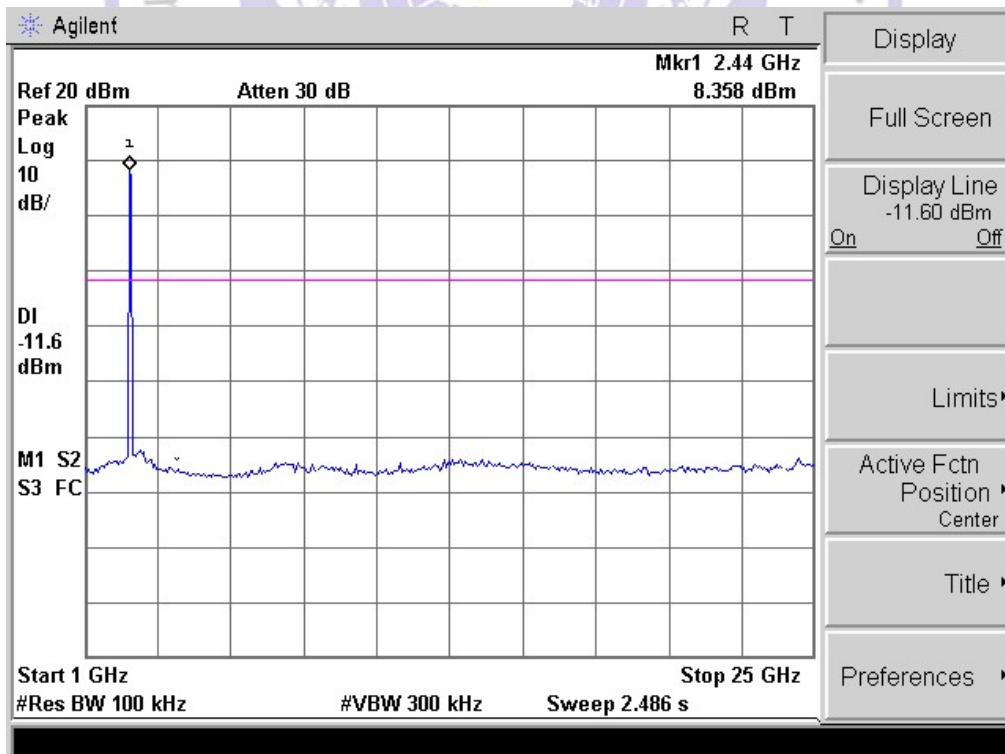
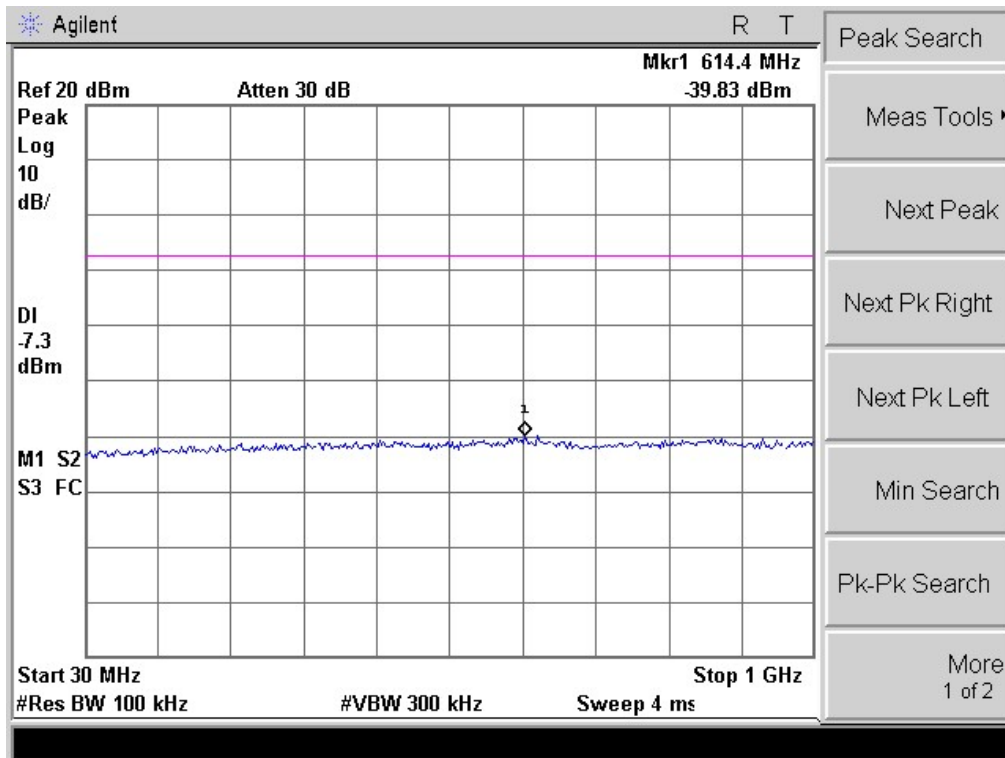

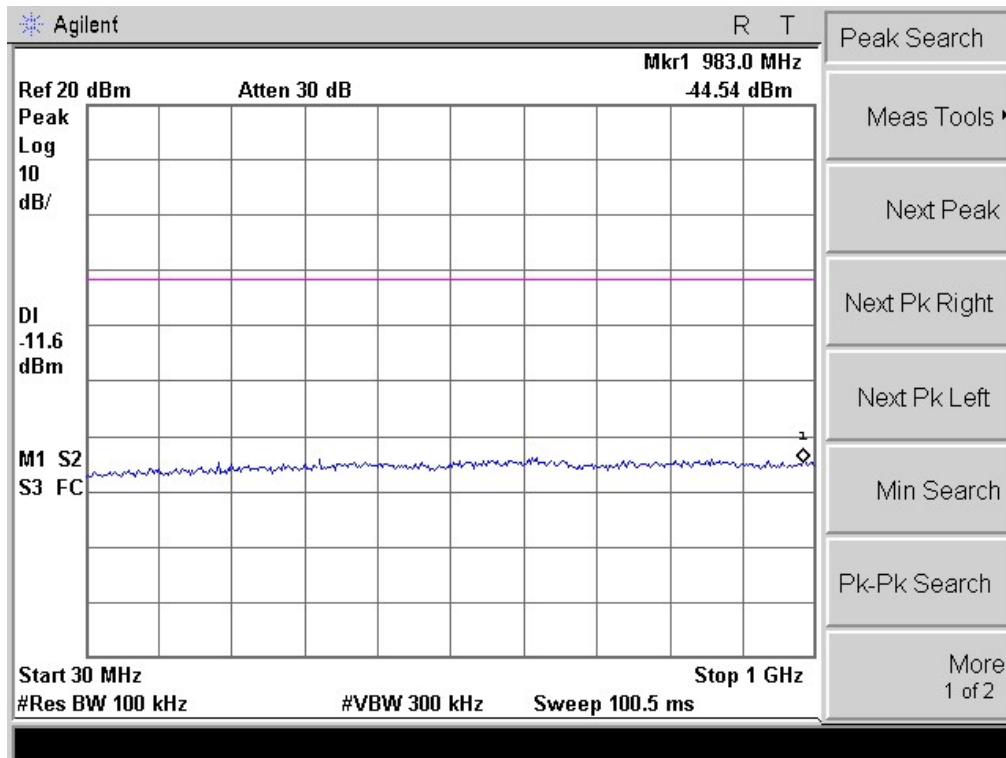

CH11 @ANT 2

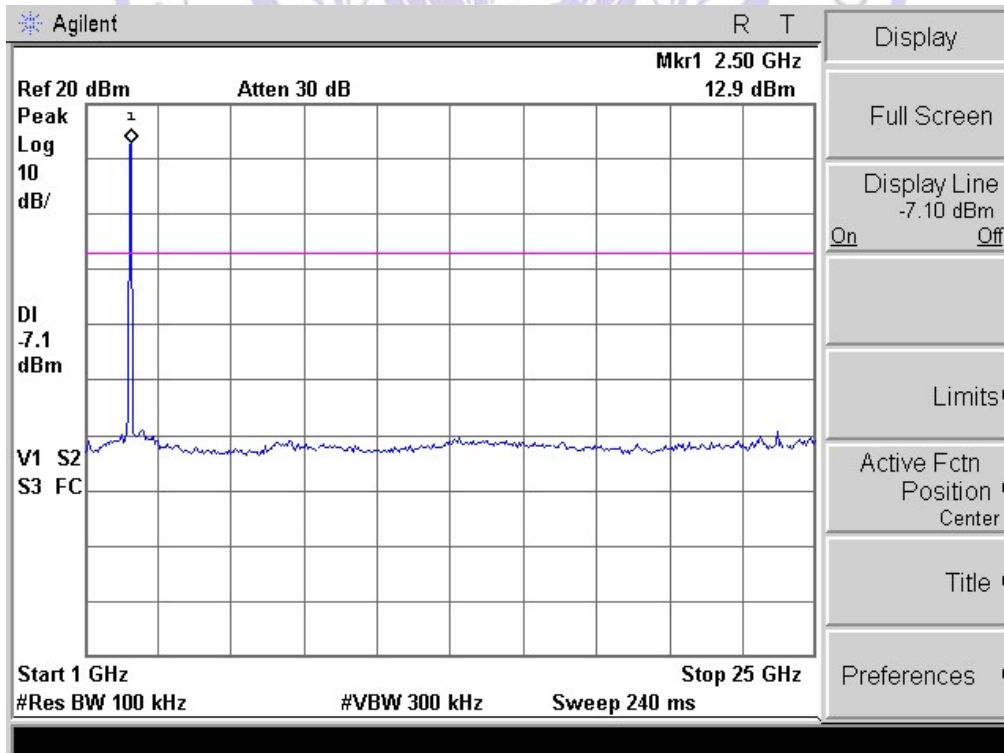

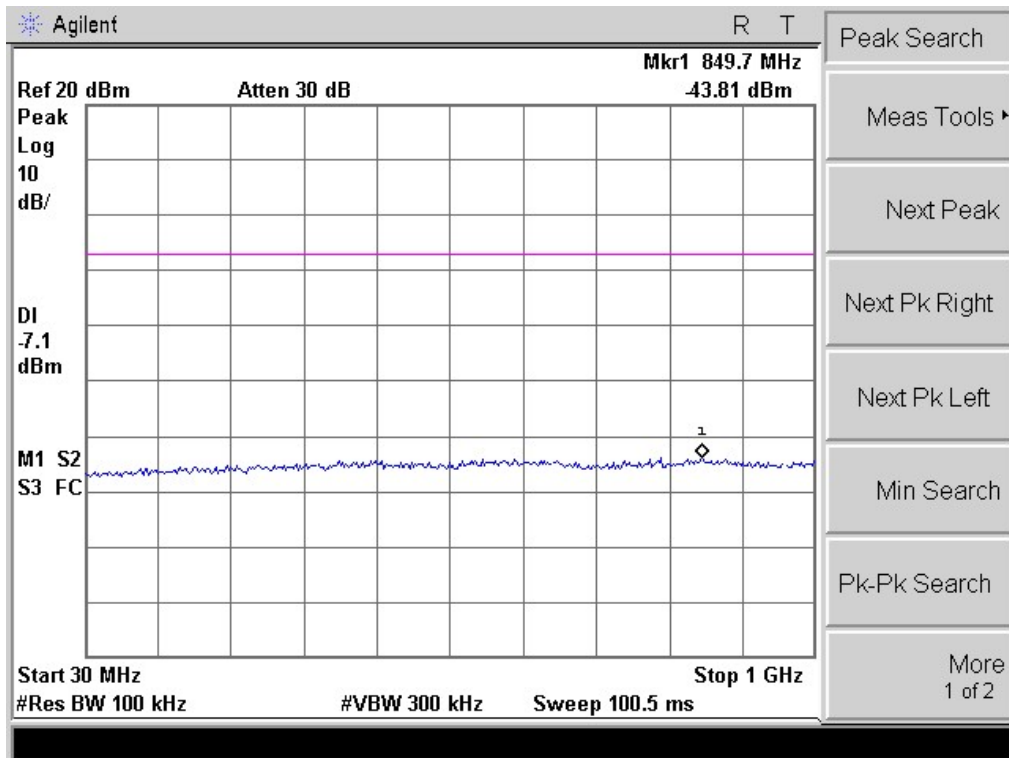

For 802.11n (20MHz) Mode:

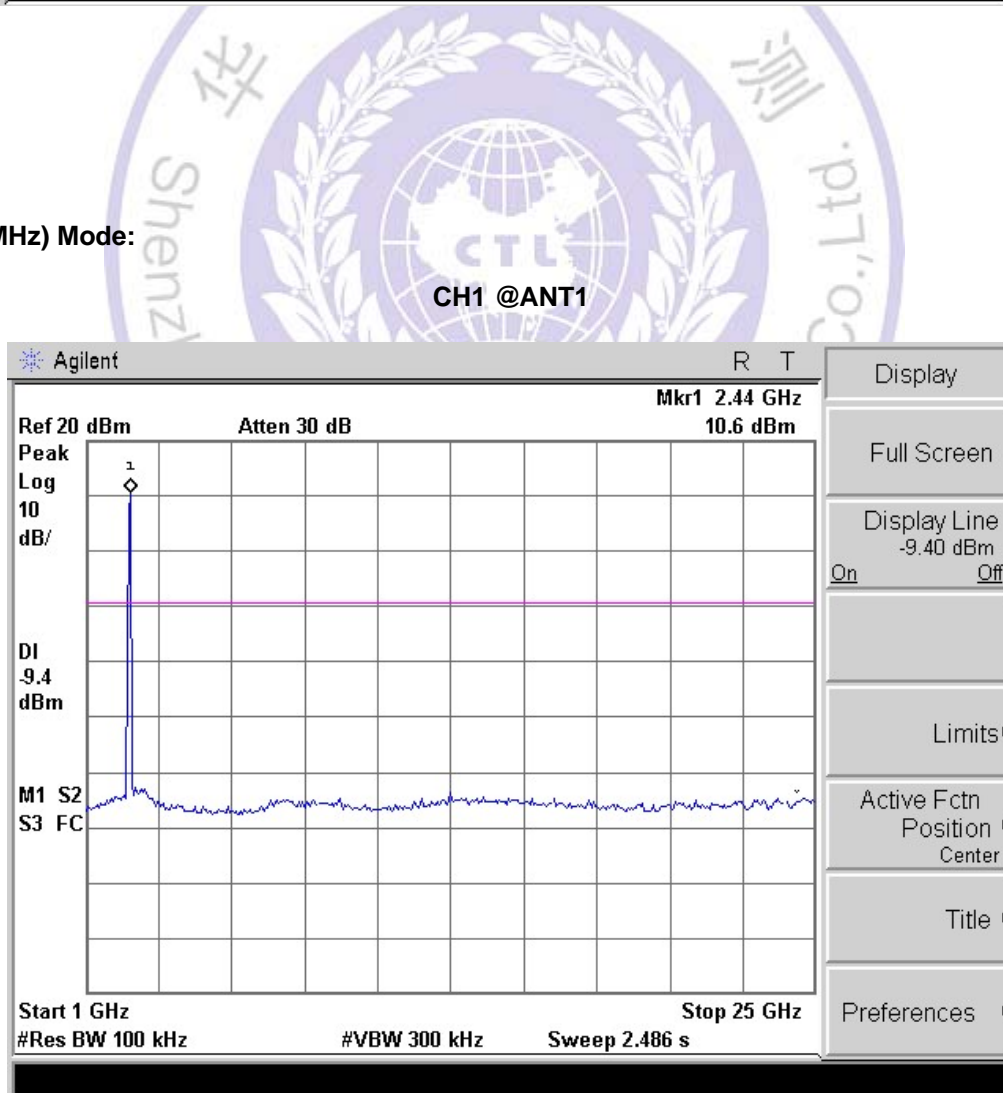

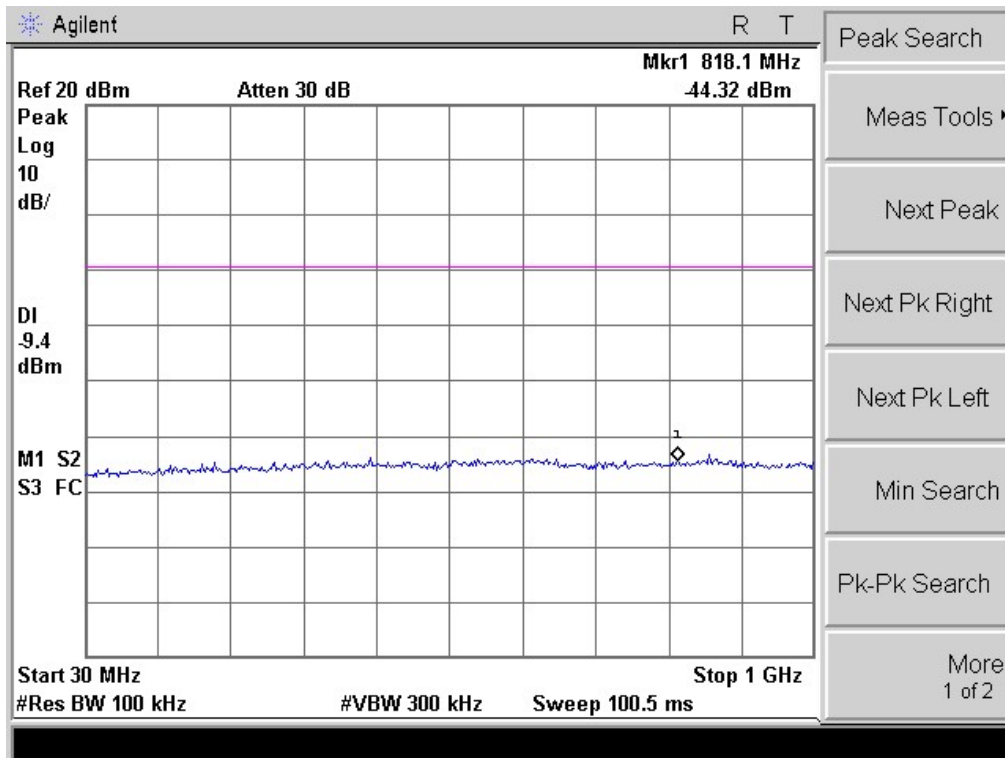

CH1 @ANT 2

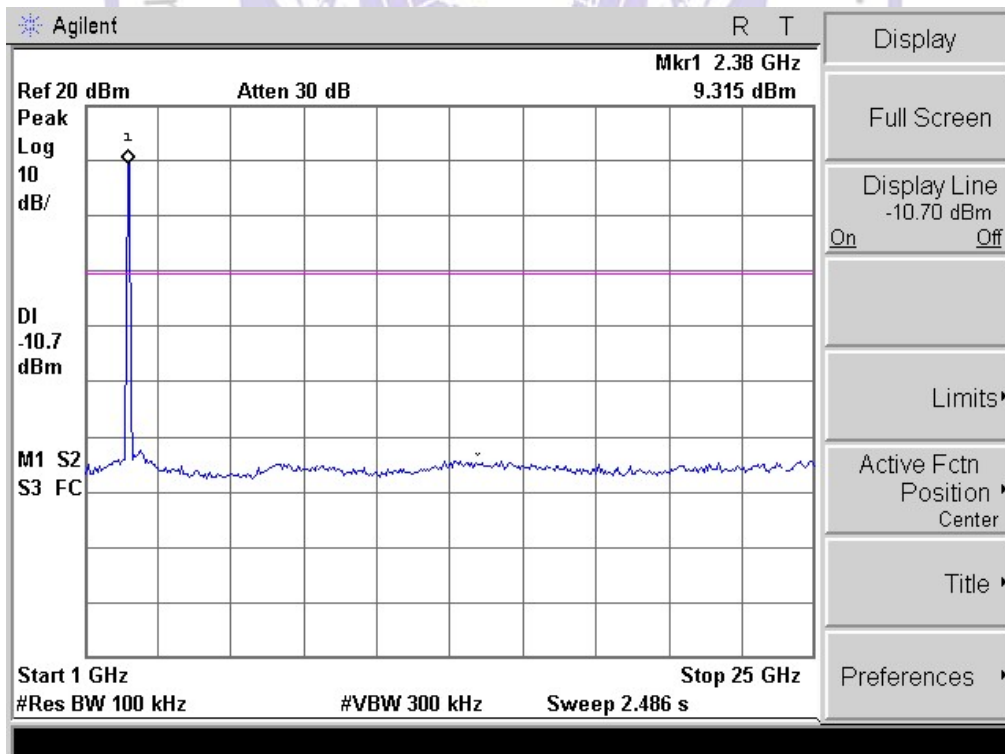

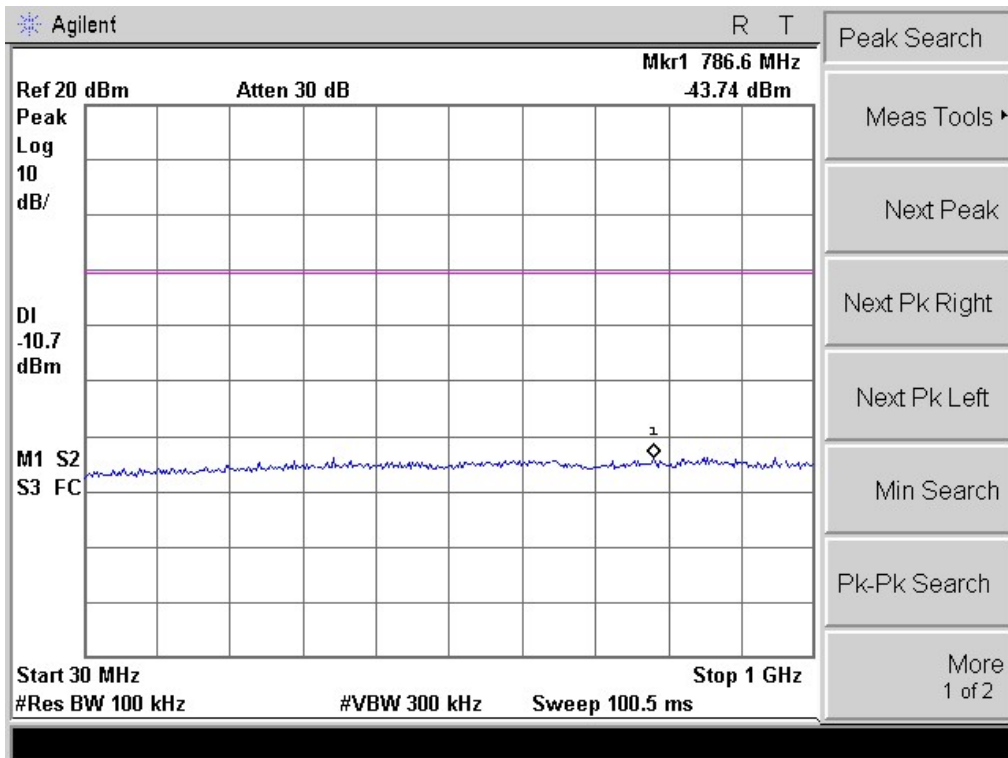

CH6 @ANT 1

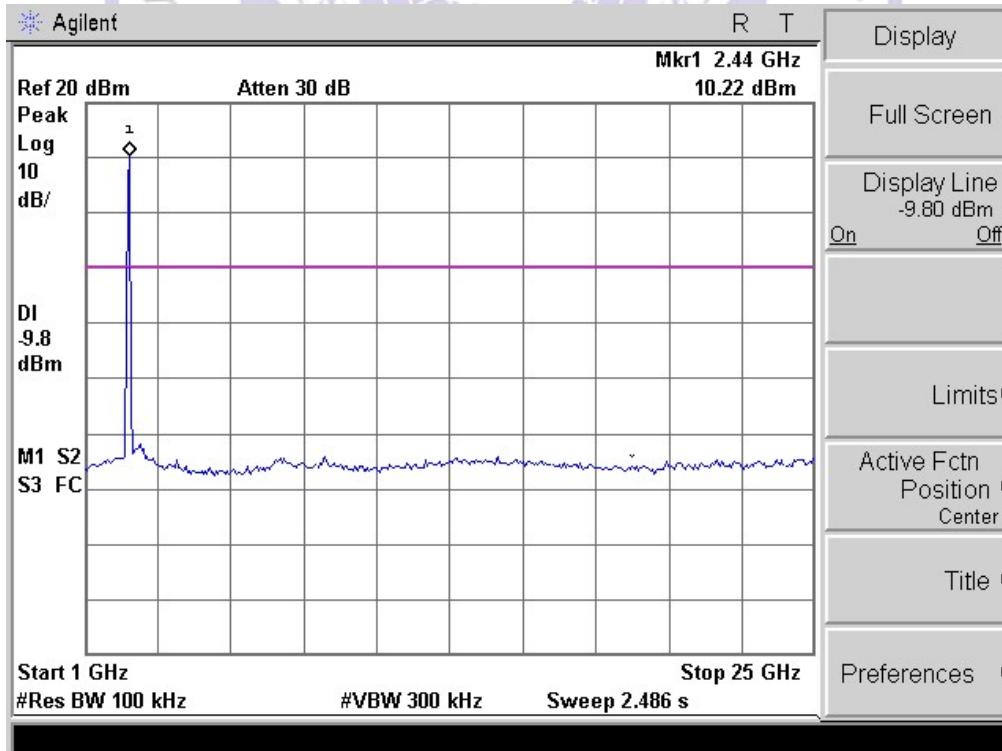

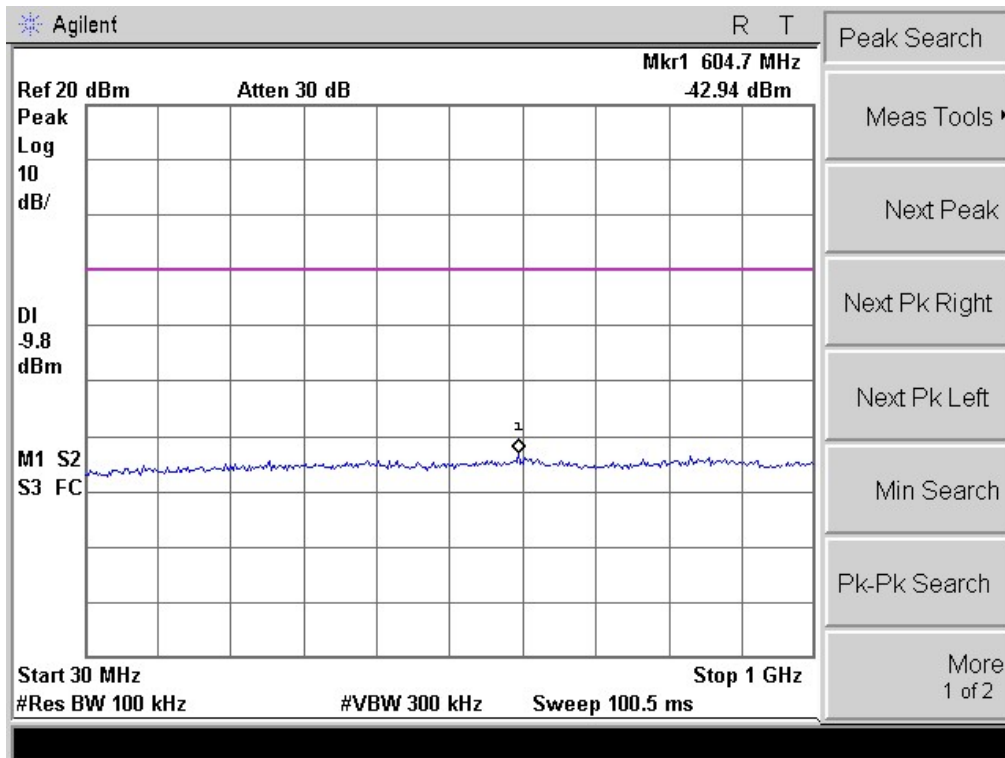

CH6 @ANT 2

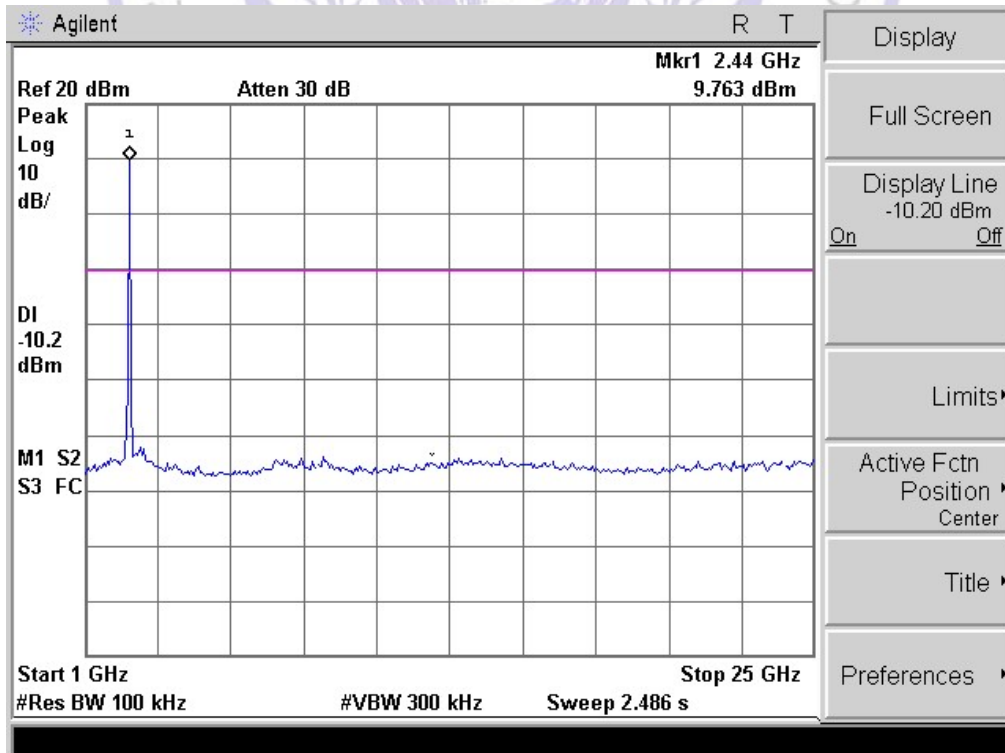

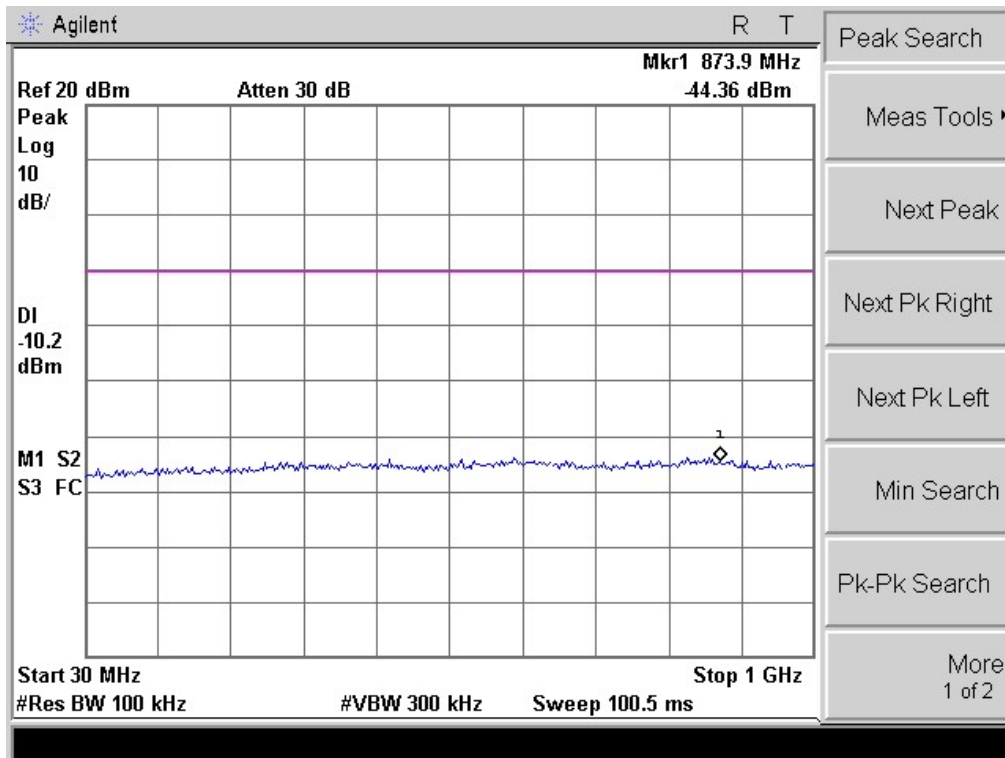

CH11 @ANT 1

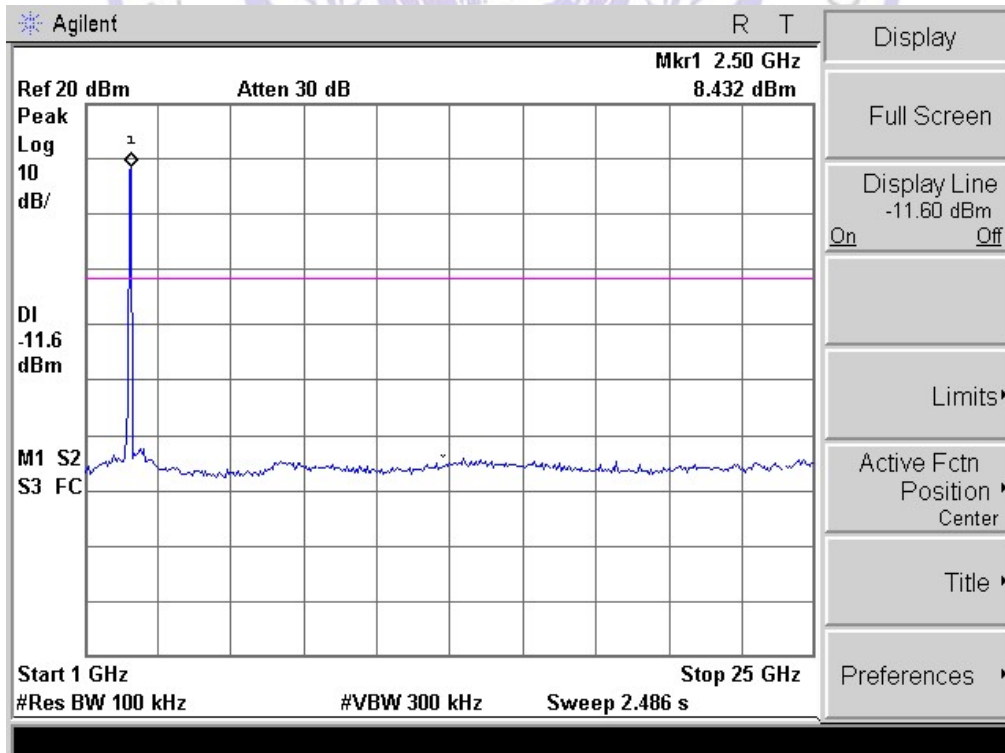

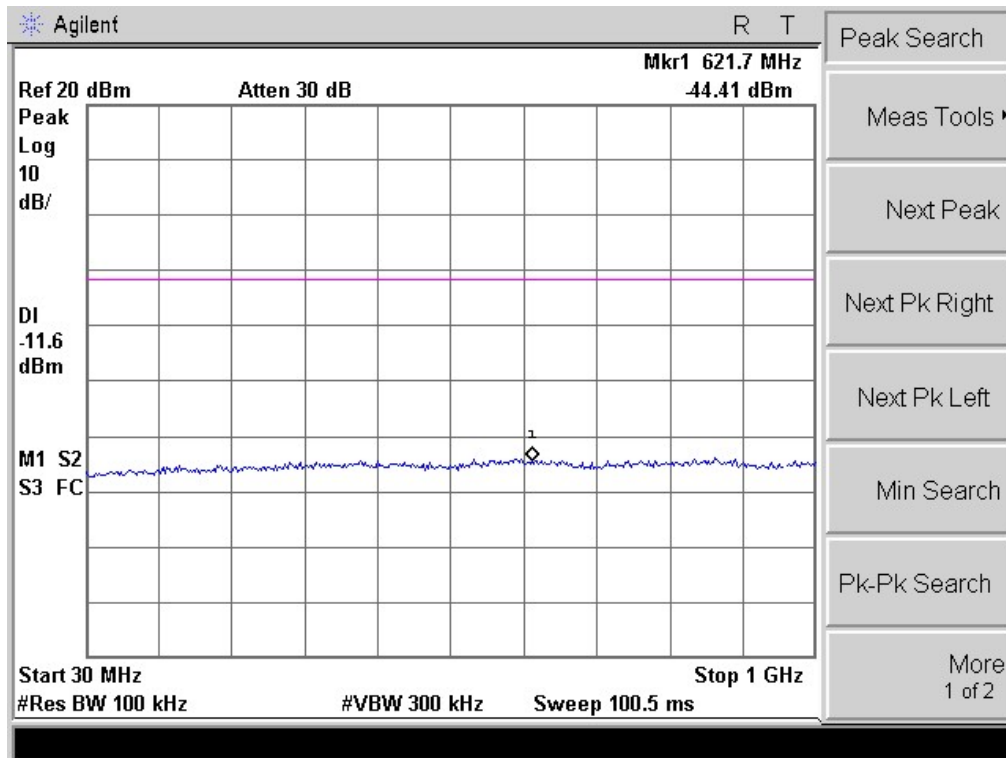

CH11 @ANT 2

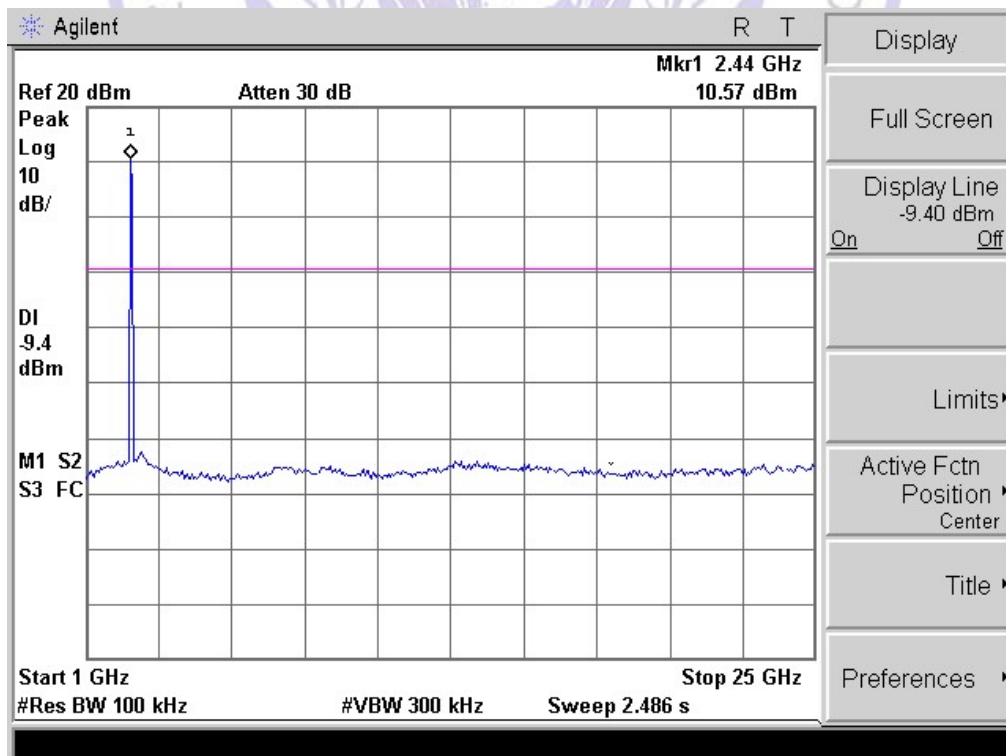

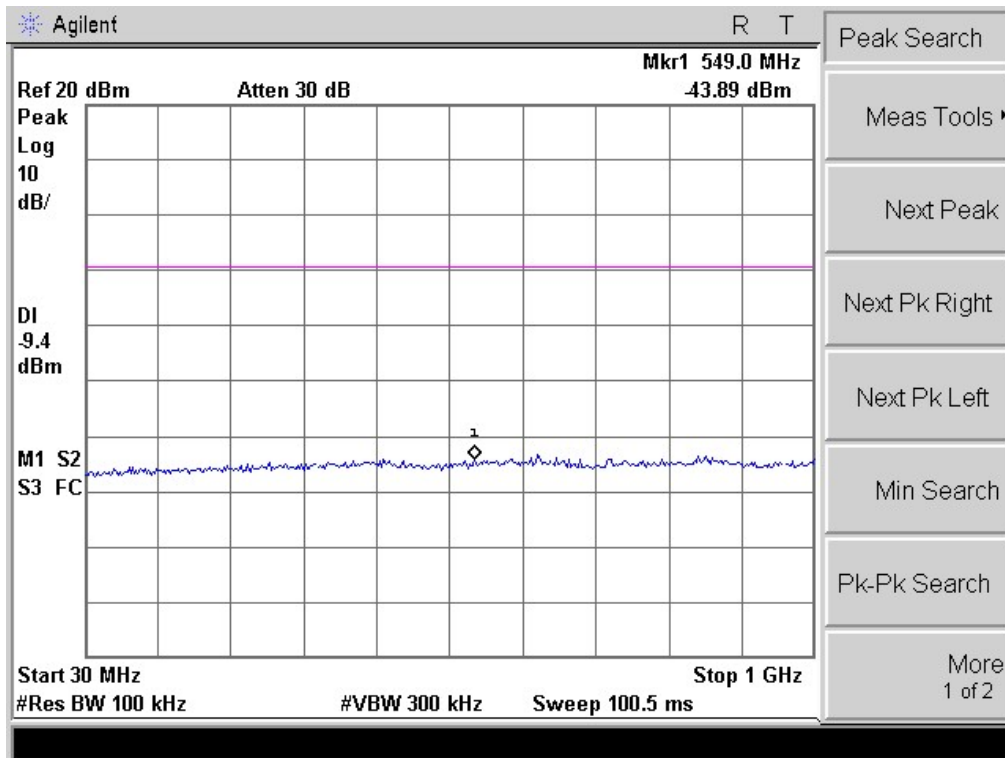

For 802.11n (40MHz) Mode:

CH3 @ANT1

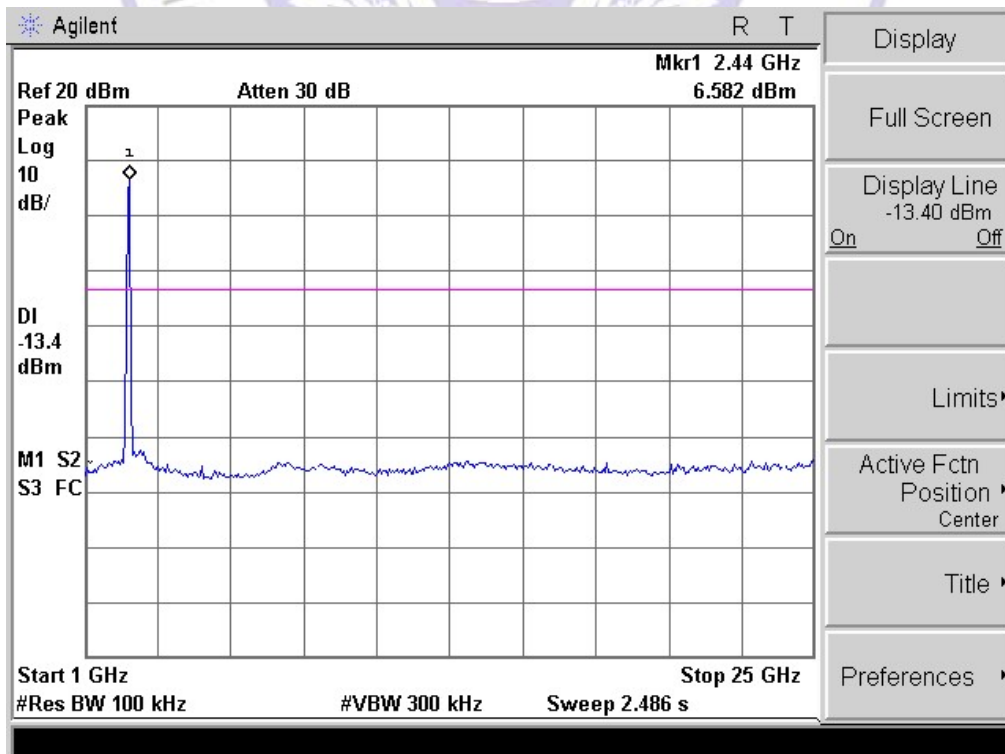

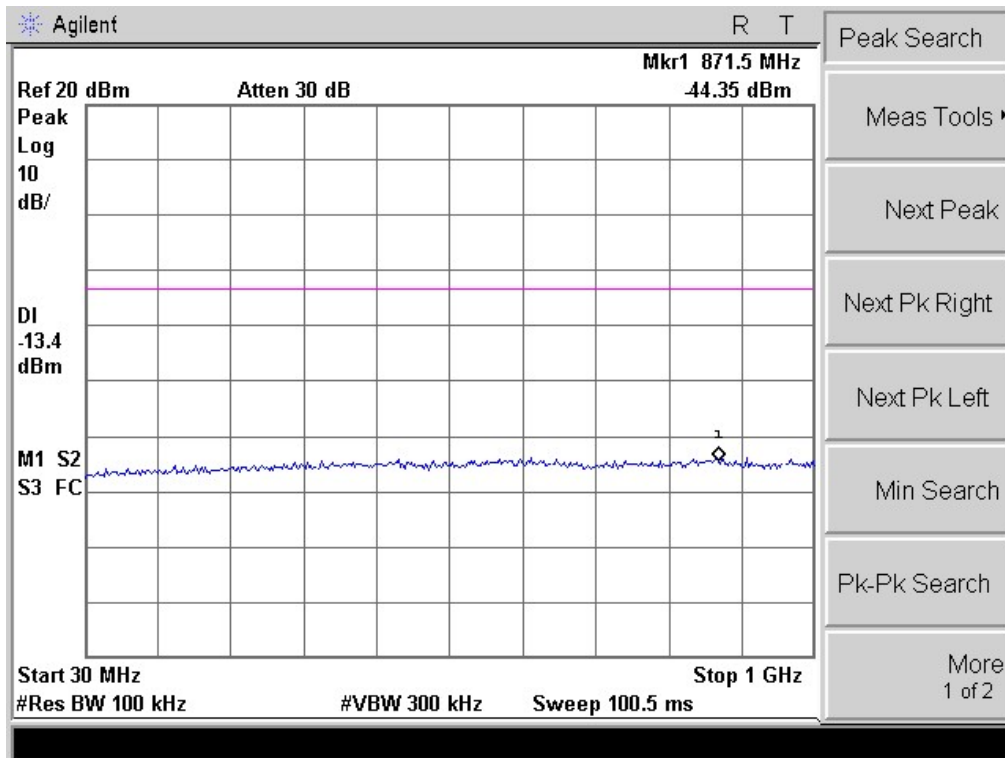

CH3 @ANT 2

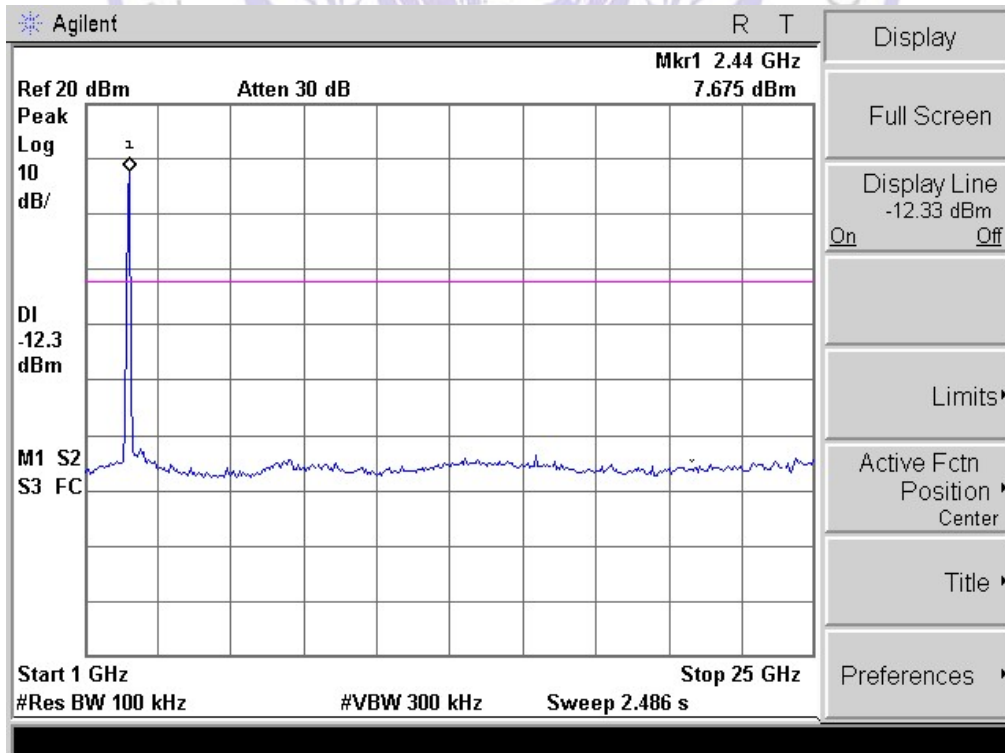

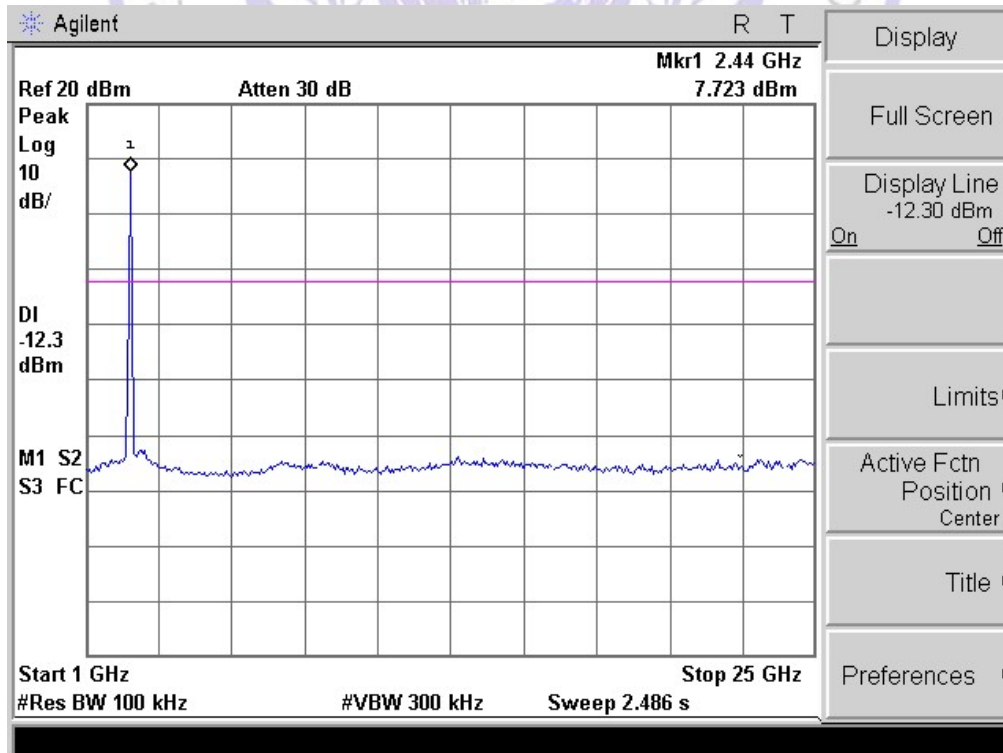
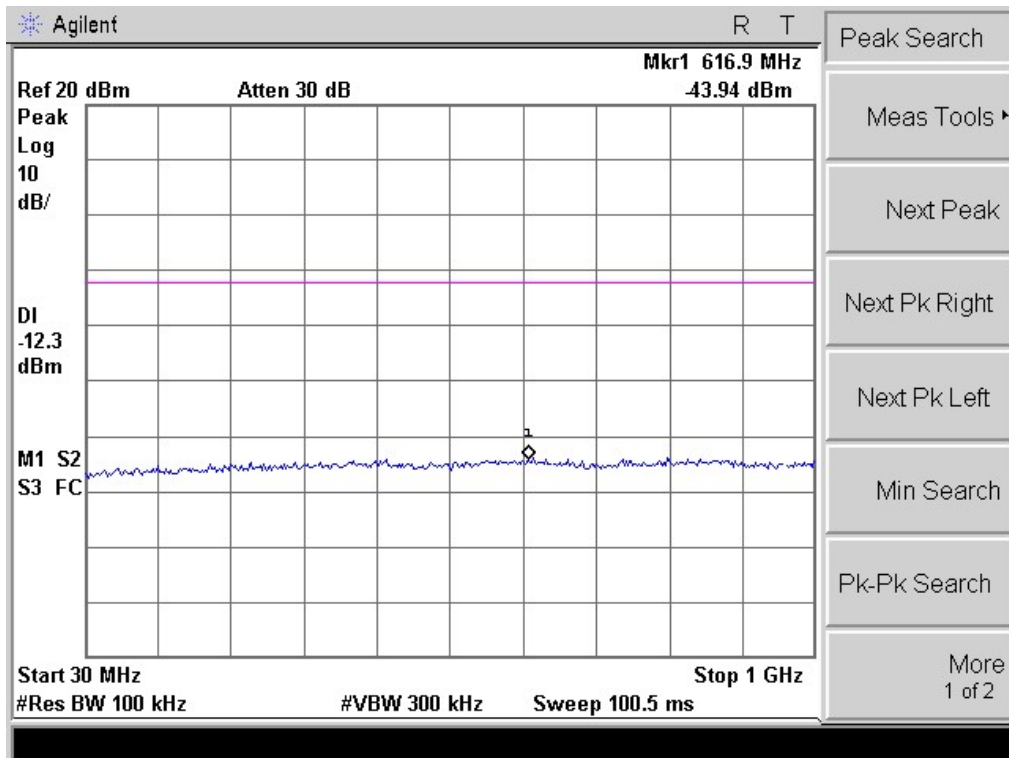

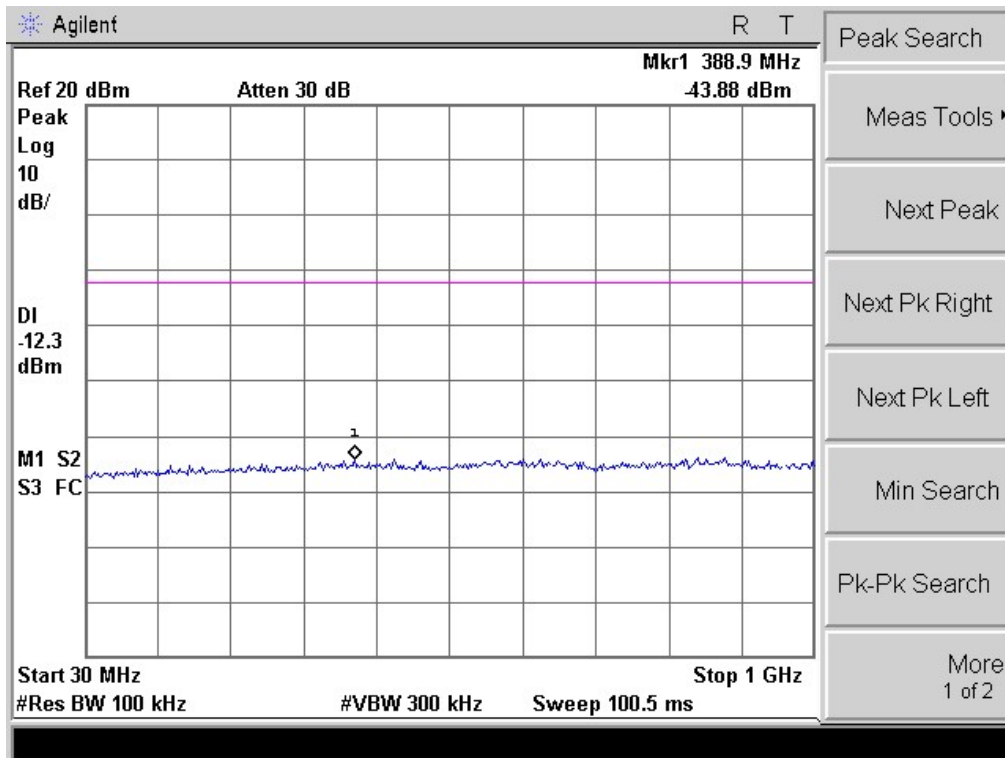

CH6 @ANT 2

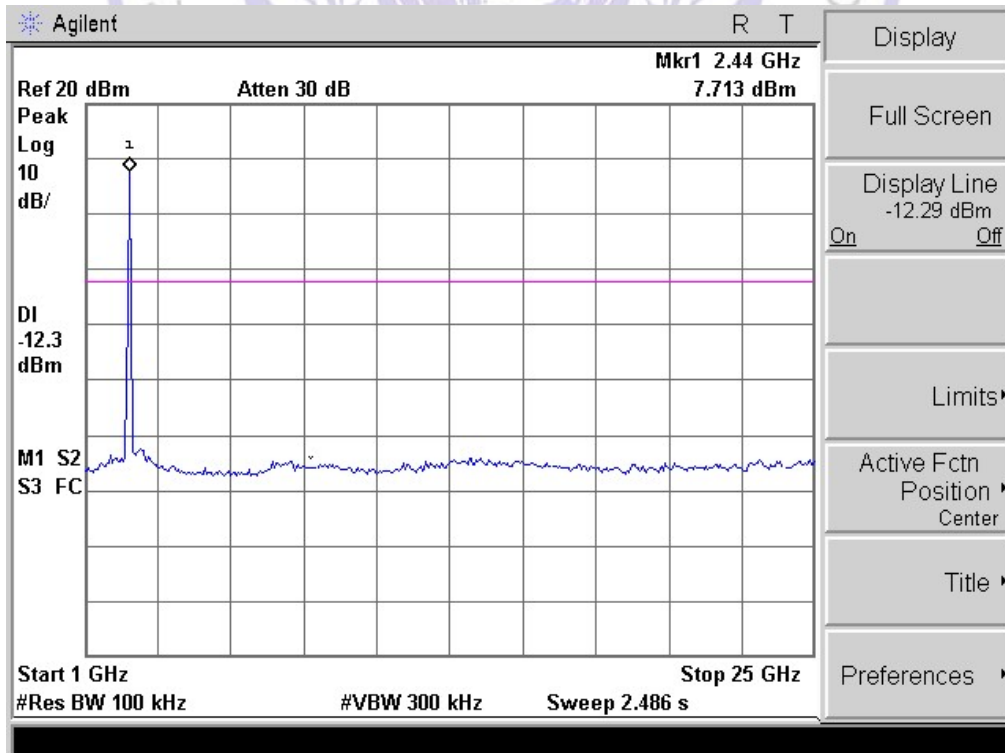

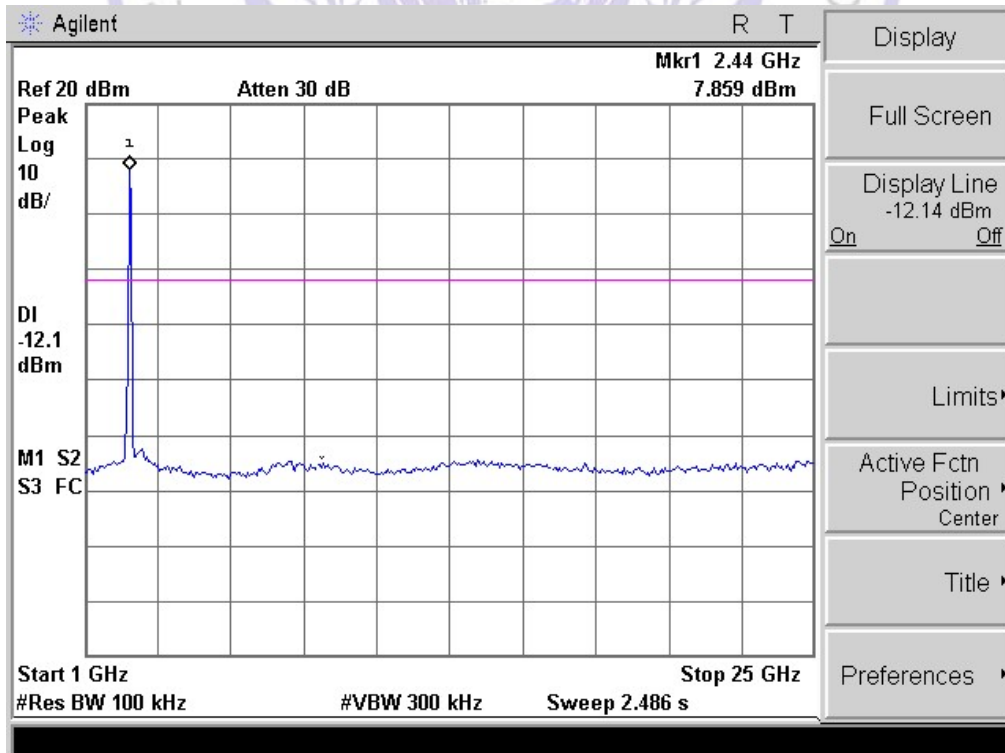
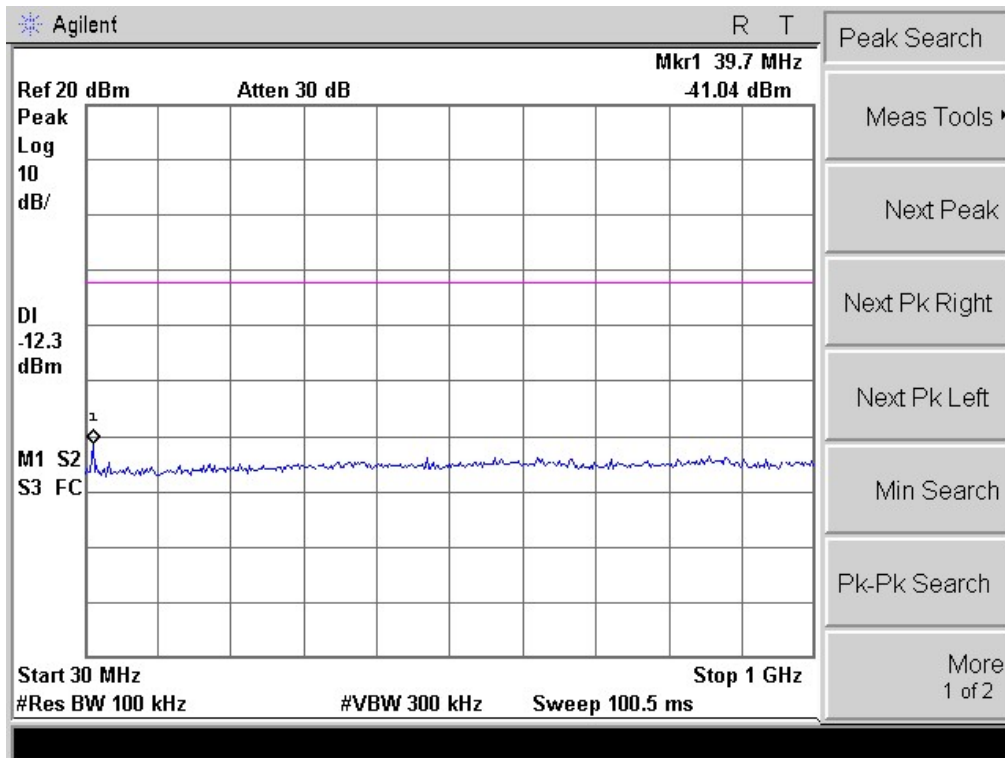

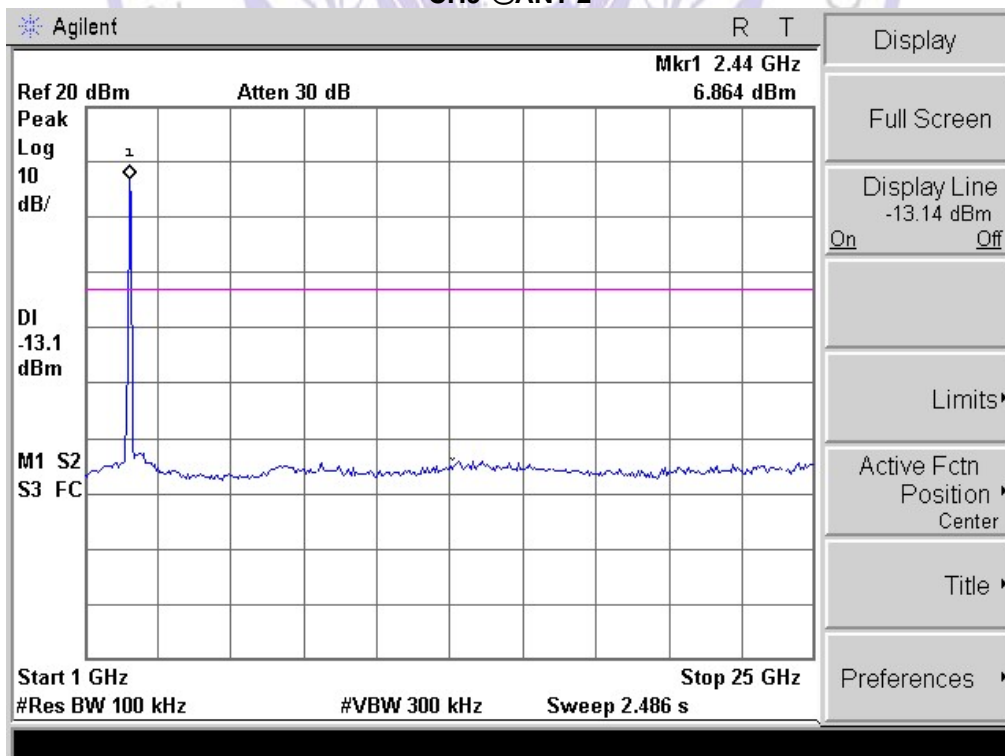
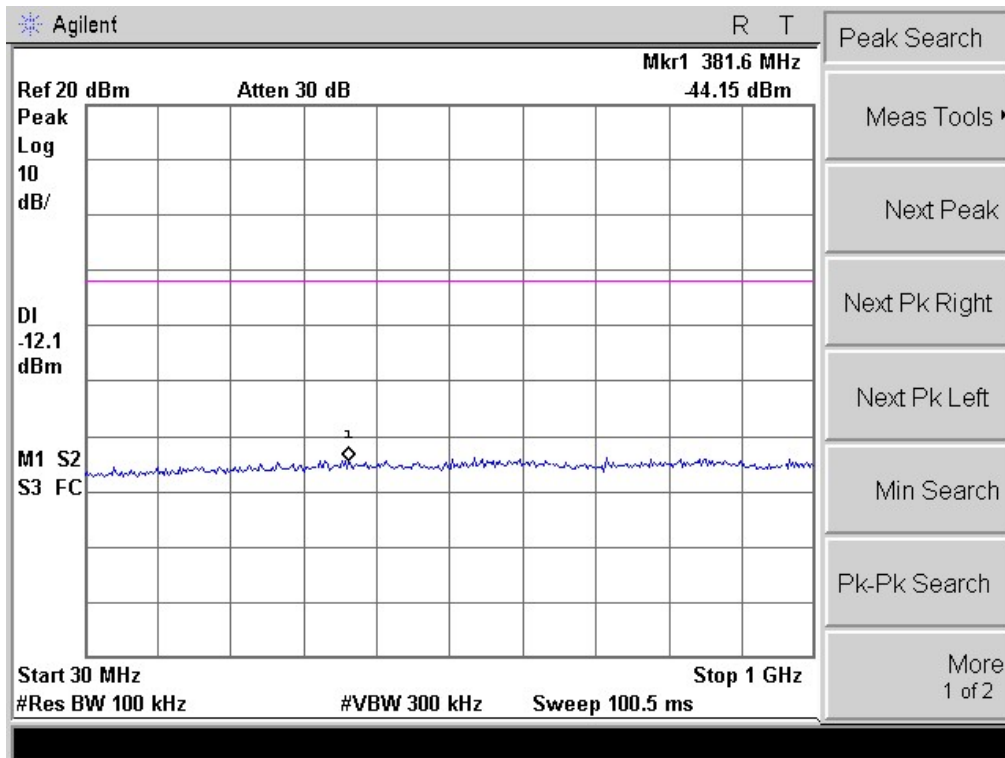

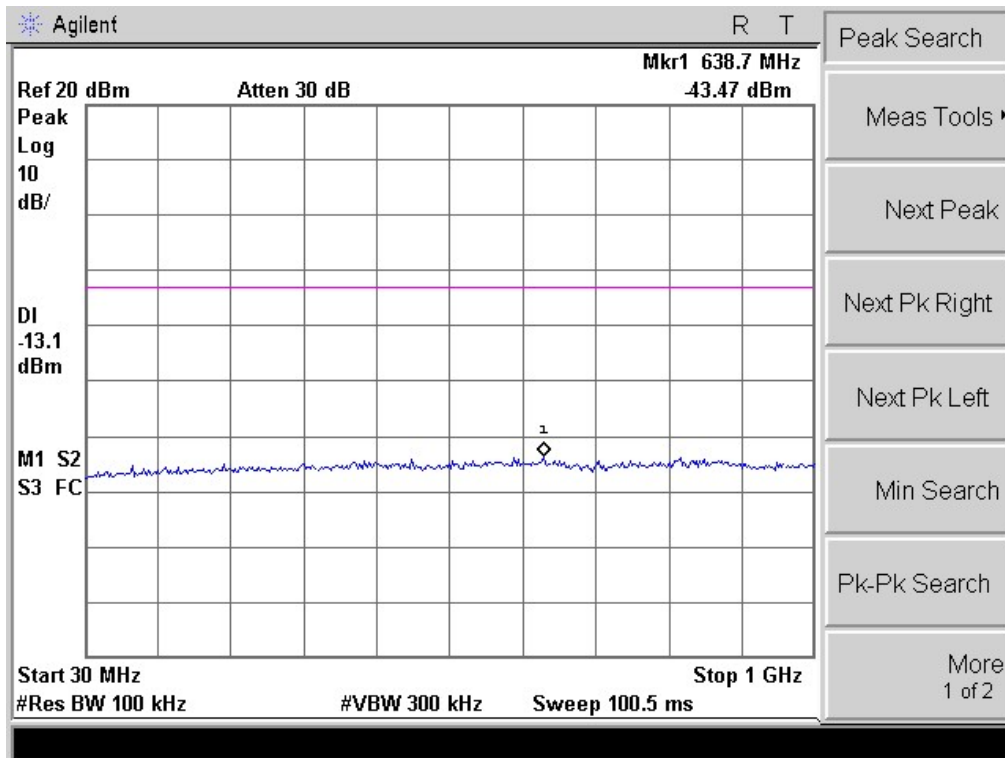

4.8. Antenna Requirement

STANDARD APPLICABLE

For intentional device, according to FCC 47 CFR Section 15.203, an intentional radiator shall be designed to ensure that no antenna other than that furnished by the responsible party shall be used with the device.

And according to FCC 47 CFR Section 15.247 (c), if transmitting antennas of directional gain greater than 6dBi are used, the power shall be reduced by the amount in dB that the directional gain of the antenna exceeds 6dBi.

Refer to statement below for compliance.

The manufacturer may design the unit so that the user can replace a broken antenna, but the use of a standard antenna jack or electrical connector is prohibited. Further, this requirement does not apply to intentional radiators that must be professionally installed.

ANTENNA CONNECTED CONSTRUCTION

The directional gains of antenna used for transmitting is 2.0 dBi, and the antenna connector is designed with permanent attachment and no consideration of replacement. Please see EUT photo for details.



5. Test Setup Photos of the EUT





6. External and Internal Photos of the EUT

External Photos of EUT







Internal Photos of EUT

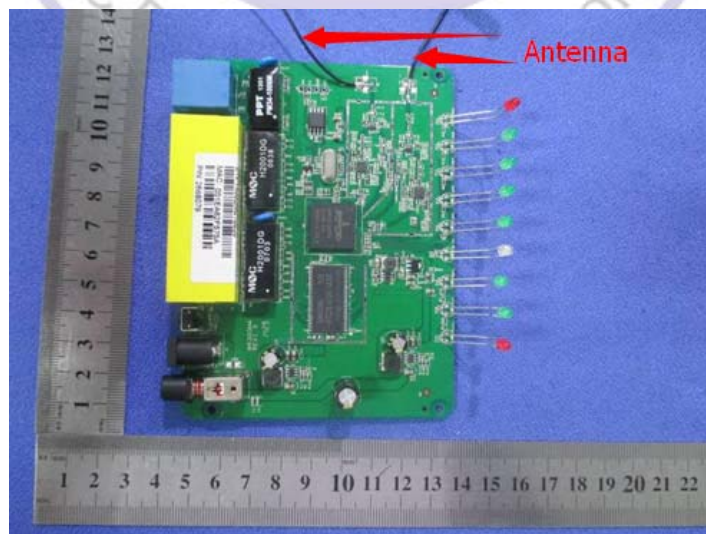
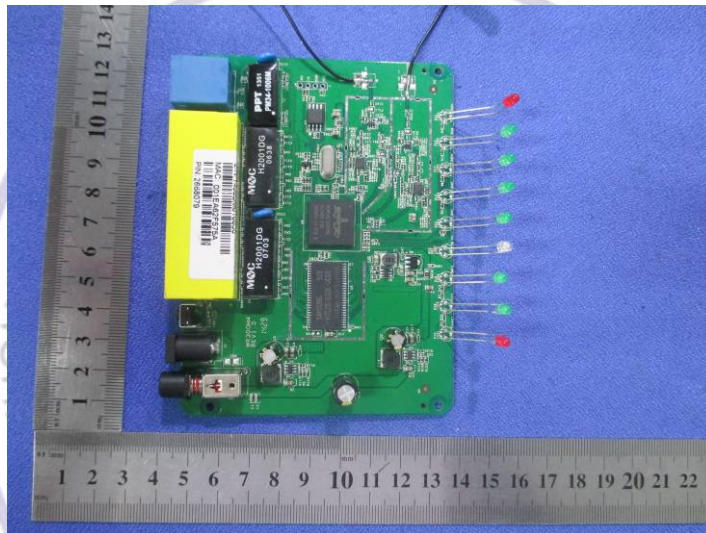

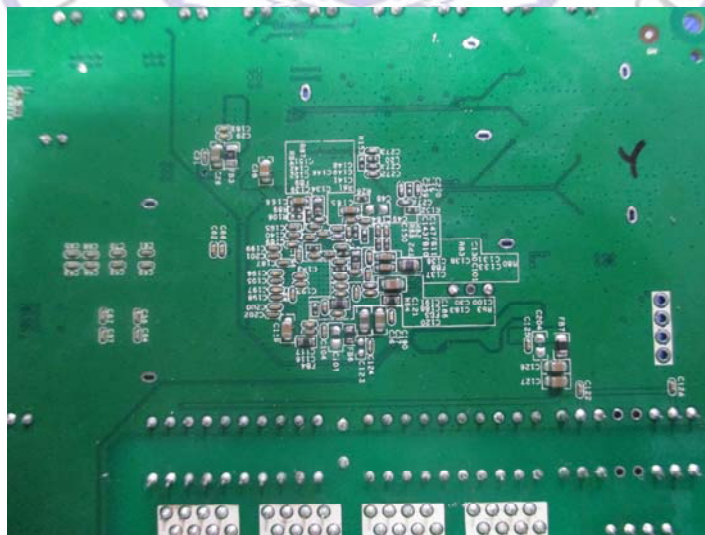
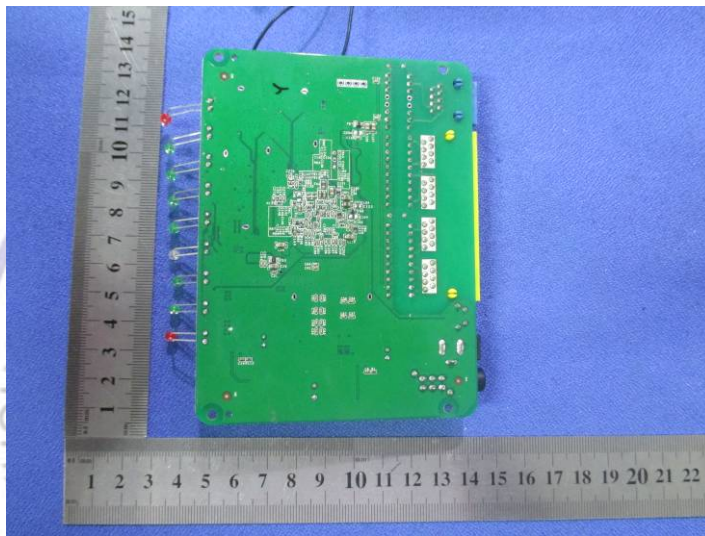

.....End of Report.....