



SAR EVALUATION REPORT

For

Yunec Technology Co., Limited

Unit 2301, 23/F, 9 Chong Yip Street · Kwun Tong, Kowloon, Hong Kong China

FCC ID: 2ACS5-YUNMQRCP

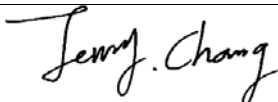
Report Type: Original Report	Product Type: Mantis Q Remote Controller
Report Number: RXZ181211002-23A	
Report Date: 2019-1-7	
Reviewed By: Jerry Chang	
Prepared By: Bay Area Compliance Laboratories Corp.(Taiwan) 70, Lane 169, Sec. 2, Datong Road, Xizhi Dist., New Taipei City 22183, Taiwan, R.O.C. Tel: +886 (2)2647 6898 Fax: +886 (2) 2647 6895 www.bacl.com.tw	

Note: This test report is prepared for the customer shown above and for the device described herein. It may not be duplicated or used in part without prior written consent from Bay Area Compliance Laboratories Corp.

Attestation of Test Results			
EUT Information	EUT Description	Mantis Q Remote Controller	
	Tested Model	YUNMQRCP	
	FCC ID	2ACS5-YUNMQRCP	
	Serial Number:	H71FVP1GH31S	
	Test Date	2018-12-5/ 2018-12-17	
MODE		Max. SAR Level(s) Reported(W/kg)	Limit(W/kg)
WLAN 2.4GHz	1g Body SAR	1.19	1.6
WLAN 5GHz	1g Body SAR	1.25	
WLAN 2.4GHz	10g Extremity SAR	1.49	4.0
WLAN 5GHz	10g Extremity SAR	1.84	
Applicable Standards	FCC 47 CFR part 2.1093 Radiofrequency radiation exposure evaluation: portable devices		
	IEEE1528:2013 IEEE Recommended Practice for Determining the Peak Spatial-Average Specific Absorption Rate (SAR) in the Human Head from Wireless Communications Devices: Measurement Techniques		
	IEC 62209-2:2010 Human exposure to radio frequency fields from hand-held and body-mounted wireless communication devices-Human models, instrumentation, and procedures-Part 2: Procedure to determine the specific absorption rate (SAR) for wireless communication devices used in close proximity to the human body (frequency range of 30 MHz to 6 GHz)		
	KDB procedures KDB 447498 D01 General RF Exposure Guidance v06 KDB 865664 D01 SAR measurement 100 MHz to 6 GHz v01r04 KDB 865664 D02 RF Exposure Reporting v01r02 KDB 248227 D01 802 11 Wi-Fi SAR v02r02		

TABLE OF CONTENTS

DOCUMENT REVISION HISTORY4

EUT DESCRIPTION5
 TECHNICAL SPECIFICATION5

REFERENCE, STANDARDS, AND GUIDELINES.....6
 SAR LIMITS7

FACILITIES.....8

DESCRIPTION OF TEST SYSTEM9

RECOMMENDED TISSUE DIELECTRIC PARAMETERS FOR HEAD AND BODY13

EQUIPMENT LIST AND CALIBRATION14
 EQUIPMENTS LIST & CALIBRATION INFORMATION14

SAR MEASUREMENT SYSTEM VERIFICATION15
 LIQUID VERIFICATION15
 SYSTEM ACCURACY VERIFICATION16
 SAR SYSTEM VALIDATION DATA17

EUT TEST STRATEGY AND METHODOLOGY20
 TEST POSITIONS FOR DEVICE OPERATING NEXT TO A PERSON’S EAR20
 CHEEK/TOUCH POSITION21
 EAR/TILT POSITION21
 TEST POSITIONS FOR BODY-WORN AND OTHER CONFIGURATIONS22
 TEST DISTANCE FOR SAR EVALUATION22
 SAR EVALUATION PROCEDURE23

CONDUCTED OUTPUT POWER MEASUREMENT24
 PROVISION APPLICABLE24
 TEST PROCEDURE24
 RADIO CONFIGURATION24
 MAXIMUM TARGET OUTPUT POWER25
 TEST RESULTS:26

STANDALONE SAR TEST EXCLUSION CONSIDERATIONS27
 ANTENNA DISTANCE TO EDGE27

SAR MEASUREMENT RESULTS28
 SAR TEST DATA28

SAR MEASUREMENT VARIABILITY33

SAR SIMULTANEOUS TRANSMISSION DESCRIPTION34

APPENDIX A MEASUREMENT UNCERTAINTY35

APPENDIX B EUT TEST POSITION PHOTOS37

APPENDIX C SAR PLOTS OF SAR MEASUREMENT38

APPENDIX D CALIBRATION CERTIFICATES39

DOCUMENT REVISION HISTORY

Revision Number	Report Number	Description of Revision	Date of Revision
1.0	RXZ181211002-23A	Original Report	2019-1-7

EUT DESCRIPTION

This report has been prepared on behalf of *Yuneeq Technology Co., Limited* and their product *Mantis Q Remote Controller*, Model: *YUNMQRCP*, FCC ID: *2AC55-YUNMQRCP*, or the EUT (Equipment under Test) as referred to in the rest of this report.

Technical Specification

Device Type:	Controller
Exposure Category:	Population / Uncontrolled
Antenna Type(s):	External Antenna
Accessories:	None
Operation Mode :	WLAN
Frequency Band:	WLAN 2.4G: 2412 -2462 WLAN 5.2G (802.11a/n): 5150-5250MHz WLAN 5.8G (802.11a/n): 5725-5850MHz
Conducted RF Power:	WLAN2.4G : 16.86 dBm WLAN5G : 25.04 dBm
Dimensions (L*W*H):	Length (168 mm)*Width (96 mm)*High (58 mm)
Power Source:	DC 3.7V from Battery and DC 5V charging by Adapter
Normal Operation:	Body Supported and Handheld

REFERENCE, STANDARDS, AND GUIDELINES

FCC:

The Report and Order requires routine SAR evaluation prior to equipment authorization of portable transmitter devices, including portable telephones. For consumer products, the applicable limit is 1.6 mW/g as recommended by the ANSI/IEEE standard C95.1-1992 [6] for an uncontrolled environment (Paragraph 65). According to the Supplement C of OET Bulletin 65 "Evaluating Compliance with FCC Guide-lines for Human Exposure to Radio frequency Electromagnetic Fields", released on Jun 29, 2001 by the FCC, the device should be evaluated at maximum output power (radiated from the antenna) under "worst-case" conditions for normal or intended use, incorporating normal antenna operating positions, device peak performance frequencies and positions for maximum RF energy coupling.

This report describes the methodology and results of experiments performed on wireless data terminal. The objective was to determine if there is RF radiation and if radiation is found, what is the extent of radiation with respect to safety limits. SAR (Specific Absorption Rate) is the measure of RF exposure determined by the amount of RF energy absorbed by human body (or its parts) – to determine how the RF energy couples to the body or head which is a primary health concern for body worn devices. The limit below which the exposure to RF is considered safe by regulatory bodies in North America is 1.6 mW/g average over 1 gram of tissue mass.

CE:

The order requires routine SAR evaluation prior to equipment authorization of portable transmitter devices, including portable telephones. For consumer products, the applicable limit is 2 mW/g as recommended by EN62209-1 for an uncontrolled environment. According to the Standard, the device should be evaluated at maximum output power (radiated from the antenna) under "worst-case" conditions for normal or intended use, incorporating normal antenna operating positions, device peak performance frequencies and positions for maximum RF energy coupling.

This report describes the methodology and results of experiments performed on wireless data terminal. The objective was to determine if there is RF radiation and if radiation is found, what is the extent of radiation with respect to safety limits. SAR (Specific Absorption Rate) is the measure of RF exposure determined by the amount of RF energy absorbed by human body (or its parts) – to determine how the RF energy couples to the body or head which is a primary health concern for body worn devices. The limit below which the exposure to RF is considered safe by regulatory bodies in Europe is 2 mW/g average over 10 gram of tissue mass.

The test configurations were laid out on a specially designed test fixture to ensure the reproducibility of measurements. Each configuration was scanned for SAR. Analysis of each scan was carried out to characterize the above effects in the device.

SAR Limits

FCC Limit

EXPOSURE LIMITS	SAR (W/kg)	
	(General Population / Uncontrolled Exposure Environment)	(Occupational / Controlled Exposure Environment)
Spatial Average (averaged over the whole body)	0.08	0.4
Spatial Peak (averaged over any 1 g of tissue)	1.60	8.0
Spatial Peak (hands/wrists/feet/ankles averaged over 10 g)	4.0	20.0

CE Limit

EXPOSURE LIMITS	SAR (W/kg)	
	(General Population / Uncontrolled Exposure Environment)	(Occupational / Controlled Exposure Environment)
Spatial Average (averaged over the whole body)	0.08	0.4
Spatial Peak (averaged over any 10 g of tissue)	2.0	10
Spatial Peak (hands/wrists/feet/ankles averaged over 10 g)	4.0	20.0

Population/Uncontrolled Environments are defined as locations where there is the exposure of individual who have no knowledge or control of their exposure.

Occupational/Controlled Environments are defined as locations where there is exposure that may be incurred by people who are aware of the potential for exposure (i.e. as a result of employment or occupation).

General Population/Uncontrolled environments Spatial Peak limit 1.6W/kg (FCC) & 2 W/kg (CE) applied to the EUT.

FACILITIES

The test site used by Bay Area Compliance Laboratories Corp. (Taiwan) to collect test data is located on

☒70, Lane 169, Sec. 2, Datong Road, Xizhi Dist., New Taipei City 22183, Taiwan, R.O.C.

Test site at Bay Area Compliance Laboratories Corp. (Taiwan) has been fully described in reports submitted to the Federal Communication Commission (FCC). The details of these reports have been found to be in compliance with the requirements of Section 2.948 of the FCC Rules on April 22, 2015. The facility also complies with the radiated and AC line conducted test site criteria set forth in ANSI C63.4-2014.

The Federal Communications Commission has the reports on file and is listed under FCC Registration No.: 974454. The test site has been approved by the FCC for public use and is listed in the FCC Public Access Link (PAL) database.

Bay Area Compliance Laboratories Corp. (Taiwan) Lab is accredited to ISO 17025 by Taiwan Accreditation Foundation (TAF code: 3180), Please refer Exhibit E “Certificate and Scope of Accreditation of ISO/IEC 17025:2005 TAF Certificate”

DESCRIPTION OF TEST SYSTEM

These measurements were performed with the automated near-field scanning system DASY6 from Schmid & Partner Engineering AG (SPEAG) which is the Fifth generation of the system shown in the figure hereinafter:

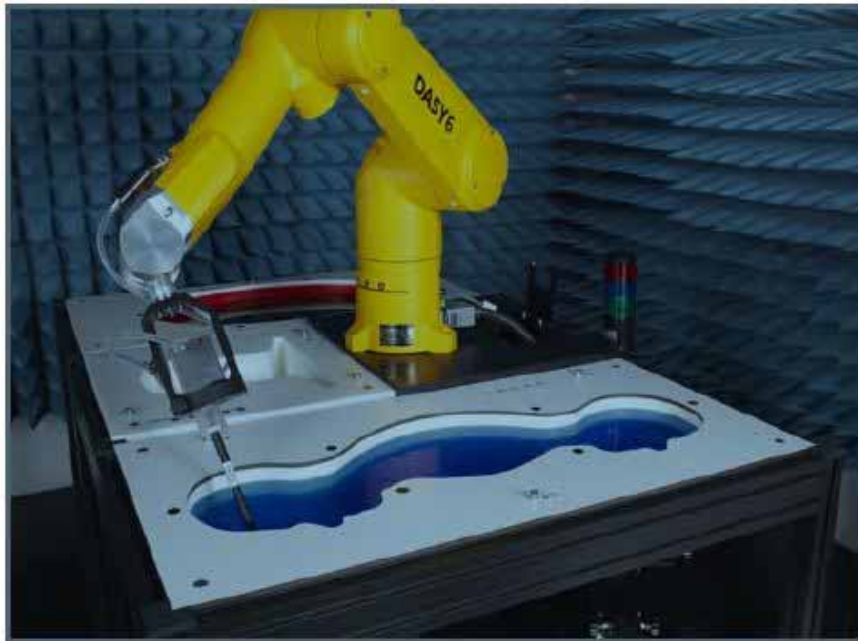

DASY6 System Description

The DASY6 system for performing compliance tests consists of the following items:

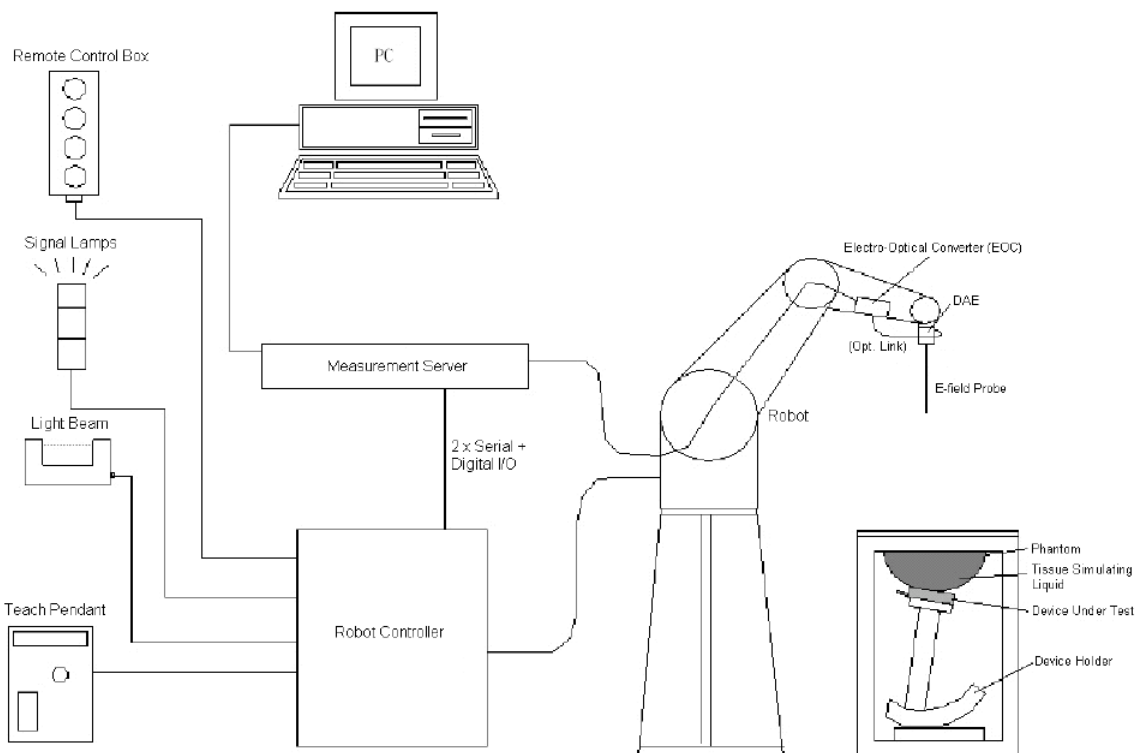

- A standard high precision 6-axis robot (Staubli TX=RX family) with controller, teach pendant and software. An arm extension for accommodating the data acquisition electronics (DAE).
- An isotropic field probe optimized and calibrated for the targeted measurement.
- A data acquisition electronics (DAE) which performs the signal application, signal multiplexing, AD-conversion, offset measurements, mechanical surface detection, collision detection, etc. The unit is battery powered with standard or rechargeable batteries. The signal is optically transmitted to the EOC.
- The Electro-optical converter (EOC) performs the conversion from optical to electrical signals for the digital communication to the DAE. To use optical surface detection, a special version of the EOC is required. The EOC signal is transmitted to the measurement server.
- The function of the measurement server is to perform the time critical tasks such as signal filtering, control of the robot operation and fast movement interrupts.
- The Light Beam used is for probe alignment. This improves the (absolute) accuracy of the probe positioning.
- A computer running Win7 professional operating system and the DASY52 software.
- Remote control and teach pendant as well as additional circuitry for robot safety such as warning lamps, etc.
- The phantom, the device holder and other accessories according to the targeted measurement.

DASY6 Measurement Server

The DASY6 measurement server is based on a PC/104 CPU board with a 400 MHz intel ULV Celeron, 128 MB chip-disk and 128 MB RAM. The necessary circuits for communication with the DAE4 (or DAE3) electronics box, as well as the 16-bit AD converter system for optical detection and digital I/O interface are contained on the DASY6 I/O board, which is directly connected to the PC/104 bus of the CPU board.



The measurement server performs all real-time data evaluations of field measurements and surface detection, controls robot movements, and handles safety operations. The PC operating system cannot interfere with these time-critical processes. All connections are supervised by a watchdog, and disconnection of any of the cables to the measurement server will automatically disarm the robot and disable all program-controlled robot movements. Furthermore, the measurement server is equipped with an expansion port, which is reserved for future applications. Please note that this expansion port does not have a standardized pinout, and therefore only devices provided by SPEAG can be connected. Connection of devices from any other supplier could seriously damage the measurement server.

Data Acquisition Electronics

The data acquisition electronics (DAE4) consist of a highly sensitive electrometer-grade preamplifier with auto-zeroing, a channel and gain-switching multiplexer, a fast 16 bit AD-converter and a command decoder with a control logic unit. Transmission to the measurement server is accomplished through an optical downlink for data and status information, as well as an optical uplink for commands and the clock.

The mechanical probe mounting device includes two different sensor systems for frontal and sideways probe contacts. They are used for mechanical surface detection and probe collision detection.

The input impedance of both the DAE4 as well as of the DAE3 box is 200M Ω ; the inputs are symmetrical and floating. Common mode rejection is above 80 dB.

EX3DV4 E-Field Probes

Frequency	10 MHz to > 6 GHz Linearity: ± 0.2 dB (30 MHz to 6 GHz)
Directivity	± 0.3 dB in TSL (rotation around probe axis) ± 0.5 dB in TSL (rotation normal to probe axis)
Dynamic Range	10 µW/g to > 100 mW/g Linearity: ± 0.2 dB (noise: typically < 1 µW/g)
Dimensions	Overall length: 337 mm (Tip: 20 mm) Tip diameter: 2.5 mm (Body: 12 mm) Typical distance from probe tip to dipole centers: 1 mm
Application	High precision dosimetric measurements in any exposure scenario (e.g., very strong gradient fields); the only probe that enables compliance testing for frequencies up to 6 GHz with precision of better 30%.
Compatibility	DASY3, DASY4, DASY52 SAR and higher, EASY4/MRI

SAM Twin Phantom

The SAM Twin Phantom (shown in front of DASY6) is a fiberglass shell phantom with shell thickness 2 mm, except in the ear region where the thickness is increased to 6 mm. The phantom has three measurement areas: 1) Left Head, 2) Right Head, and 3) Flat Section. For larger devices, the use of the ELI-Phantom (shown behind DASY6) is required. For devices such as glasses with a wireless link, the Face Down Phantom is the most suitable (between the SAM Twin and ELI phantoms).

When the phantom is mounted inside allocated slot of the DASY6 platform, phantom reference points can be taught directly in the DASY5 V5.2 software. When the DASY6 platform is used to mount the

phantom, some of the phantom teaching points cannot be reached by the robot in DASY5 V5.2. A special tool called P1a-P2aX-Former is provided to transform two of the three points, P1 and P2, to reachable locations. To use these new teaching points, a revised phantom configuration file is required.

In addition to our standard broadband liquids, the phantom can be used with the following tissue simulating liquids:

Sugar-water-based liquids can be left permanently in the phantom. Always cover the liquid when the system is not in use to prevent changes in liquid parameters due to water evaporation. DGBE-based liquids should be used with care. As DGBE is a softener for most plastics, the liquid should be taken out of the phantom, and the phantom should be dried when the system is not in use (desirable at least once a week).

- Do not use other organic solvents without previously testing the solvent resistivity of the phantom. Approximately 25 liters of liquid is required to fill the SAM Twin phantom.



Tissue Dielectric Parameters for Head and Body Phantoms

The head tissue dielectric parameters recommended by the IEEE SCC-34/SC-2 in P1528 have been incorporated in the following table. These head parameters are derived from planar layer models simulating the highest expected SAR for the dielectric properties and tissue thickness variations in a human head. Other head and body tissue parameters that have not been specified in P1528 are derived from the tissue dielectric parameters computed from the 4-Cole-Cole equations described in Reference [12] and extrapolated according to the head parameters specified in P1528.

Robots

The DASY6 system uses the high-precision industrial robots TX60L, TX90XL, and RX160L from Staubli SA (France). The TX robot family - the successor of the well-known RX robot family - continues to offer the features important for DASY6 applications:

- High precision (repeatability 0.02mm)
- High reliability (industrial design)
- Low maintenance costs (virtually maintenance free due to direct drive gears; no belt drives)
- Jerk-free straight movements (brushless synchrony motors; no stepper motors)
- Low ELF interference (motor control fields shielded via the closed metallic construction shields)

The robots are controlled by the Staubli CS8c robot controllers. All information regarding the use and maintenance of the robot arm and the robot controller is provided

Area Scans

Area scans are defined prior to the measurement process being executed with a user defined variable spacing between each measurement point (integral) allowing low uncertainty measurements to be conducted. Scans defined for FCC applications utilize a 15mm 2 step integral, with 1.5mm interpolation used to locate the peak SAR area used for zoom scan assessments.

Where the system identifies multiple SAR peaks (which are within 25% of peak value) the system will provide the user with the option of assessing each peak location individually for zoom scan averaging.

Zoom Scan (Cube Scan Averaging)

The averaging zoom scan volume utilized in the DASY4 software is in the shape of a cube and the side dimension of a 1 g or 10 g mass is dependent on the density of the liquid representing the simulated tissue. A density of 1000 kg/m³ is used to represent the head and body tissue density and not the phantom liquid density, in order to be consistent with the definition of the liquid dielectric properties, i.e. the side length of the 1g cube is 10mm, with the side length of the 10g cube is 21.5mm.

When the cube intersects with the surface of the phantom, it is oriented so that 3 vertices touch the surface of the shell or the center of a face is tangent to the surface. The face of the cube closest to the surface is modified in order to conform to the tangent surface.

The zoom scan integer steps can be user defined so as to reduce uncertainty, but normal practice for typical test applications (including FCC) utilize a physical step of 7 x 7 x 7 (5mmx5mmx5mm) providing a volume of 30 mm in the X & Y & Z axis.

Recommended Tissue Dielectric Parameters for Head and Body

Frequency (MHz)	Head Tissue		Body Tissue	
	ϵ_r	σ (S/m)	ϵ_r	σ (S/m)
150	52.3	0.76	61.9	0.80
300	45.3	0.87	58.2	0.92
450	43.5	0.87	56.7	0.94
835	41.5	0.90	55.2	0.97
900	41.5	0.97	55.0	1.05
915	41.5	0.98	55.0	1.06
1450	40.5	1.20	54.0	1.30
1610	40.3	1.29	53.8	1.40
1800-2000	40.0	1.40	53.3	1.52
2450	39.2	1.80	52.7	1.95
3000	38.5	2.40	52.0	2.73
5800	35.3	5.27	48.2	6.00

Tissue Dielectric Parameters for Head and Body Phantoms

The head tissue dielectric parameters recommended by the IEEE SCC-34/SC-2 in P1528 have been incorporated in the following table. These head parameters are derived from planar layer models simulating the highest expected SAR for the dielectric properties and tissue thickness variations in a human head. Other head and body tissue parameters that have not been specified in P1528 are derived from the tissue dielectric parameters computed from the 4-Cole-Cole equations described in Reference [12] and extrapolated according to the head parameters specified in P1528.

EQUIPMENT LIST AND CALIBRATION

Equipments List & Calibration Information

Equipment	Model	S/N	Calibration Date	Calibration Due Date
Robot	TX90	5N26A1	N.C.R	N.C.R
DASY5 Test Software	DASY5.2	N/A	N.C.R	N.C.R
DASY6 Measurement Server	DASY 6	1588	N/A	N/A
Data Acquisition Electronics	DAE4	1561	2018/11/7	2019/11/6
E-Field Probe	EX3DV4	7520	2018/11/5	2019/11/4
Dipole,2450MHz	D2450V2	969	2018/5/30	2021/5/29
Dipole,5GHz	D5GHzV2	1225	2018/5/25	2021/5/24
Mounting Device	N/A	SD 000 H01 KA	N.C.R	N.C.R
Twin ELI	Twin ELI V8.0	2088	N.C.R	N.C.R
Simulated Tissue 2450 MHz Body	TS-2450-B	2450B	Each Time	/
Simulated Tissue 5GHz Body	TS-5G-B	5GB	Each Time	/
Network Analyzer	8753D	3410A05361	2018/3/22	2019/3/21
Functional radio communication tester	CMW 290	101741	2018/8/17	2019/8/16
Signal Generator	8648C	3623A02870	2018/5/18	2019/5/17
Power Meter	E4418B	US39402167	2018/5/17	2019/5/16
Power Sensor	E9300A	US39210953	2018/5/17	2019/5/16
Power Amplifier	ZHL-42W+	329401642	2018/1/11	2019/1/10
Directional Coupler	488Z	000810	N.C.R	N.C.R
Attenuator	20dB, 100W	1453	N.C.R	N.C.R

SAR MEASUREMENT SYSTEM VERIFICATION

Liquid Verification

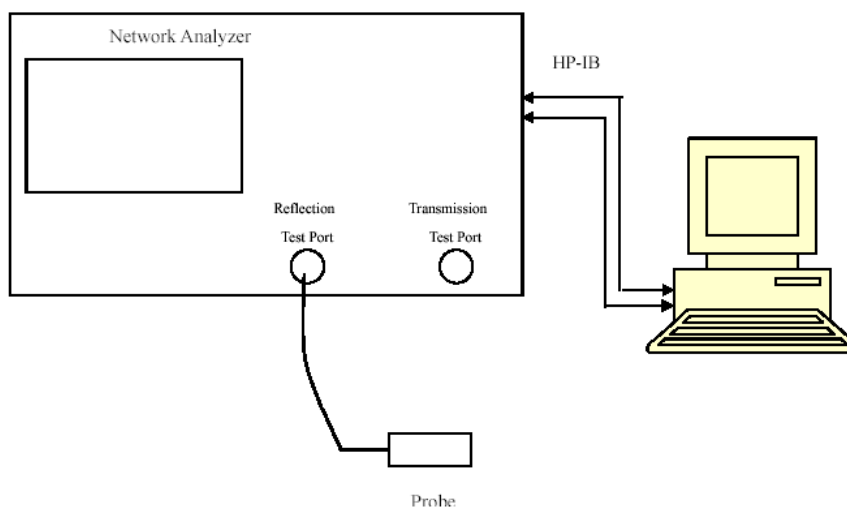

Liquid Verification Setup Block Diagram

Liquid Verification Results

Frequency (MHz)	Liquid Type	Liquid Parameter		Target Value		Delta (%)		Tolerance (%)
		σ (S/m)	ϵ_r	σ (S/m)	ϵ_r	σ (S/m)	$\Delta\epsilon_r$	
2450	Body Tissue_2450 MHz	1.975	53.096	1.95	52.70	1.28	0.75	± 5
2412	Body Tissue_2450 MHz	1.924	53.238	1.91	52.75	0.73	0.93	± 5
2437	Body Tissue_2450 MHz	1.958	53.141	1.94	52.72	0.93	0.80	± 5
2462	Body Tissue_2450 MHz	1.991	53.042	1.97	52.68	1.07	0.69	± 5

*Liquid Verification above was performed on 2018-12-5

Frequency (MHz)	Liquid Type	Liquid Parameter		Target Value		Delta (%)		Tolerance (%)
		σ (S/m)	ϵ_r	σ (S/m)	ϵ_r	σ (S/m)	$\Delta\epsilon_r$	
5180	Body Tissue_5 GHz	5.427	47.062	5.28	49.03	2.78	-4.01	± 5
5200	Body Tissue_5 GHz	5.452	47.038	5.30	49.00	2.87	-4.00	± 5
5240	Body Tissue_5 GHz	5.501	46.977	5.35	48.96	2.82	-4.05	± 5
5800	Body Tissue_5 GHz	6.234	46.020	6.00	48.20	3.90	-4.52	± 5
5745	Body Tissue_5 GHz	6.168	46.132	5.94	48.28	3.84	-4.45	± 5
5785	Body Tissue_5 GHz	6.21	46.07	5.98	48.22	3.85	-4.46	± 5
5825	Body Tissue_5 GHz	6.274	45.99	6.00	48.2	4.57	-4.59	± 5

*Liquid Verification above was performed on 2018-12-17

System Accuracy Verification

Prior to the assessment, the system validation kit was used to test whether the system was operating within its specifications of $\pm 10\%$. The validation results are tabulated below. And also the corresponding SAR plot is attached as well in the SAR plots files.

The spacing distances in the **System Verification Setup Block Diagram** is given by the following:

- a) $s = 15 \text{ mm} \pm 0,2 \text{ mm}$ for $300 \text{ MHz} \leq f \leq 1\,000 \text{ MHz}$;
- b) $s = 10 \text{ mm} \pm 0,2 \text{ mm}$ for $1\,000 \text{ MHz} < f \leq 3\,000 \text{ MHz}$;
- c) $s = 10 \text{ mm} \pm 0,2 \text{ mm}$ for $3\,000 \text{ MHz} < f \leq 6\,000 \text{ MHz}$.

System Verification Setup Block Diagram

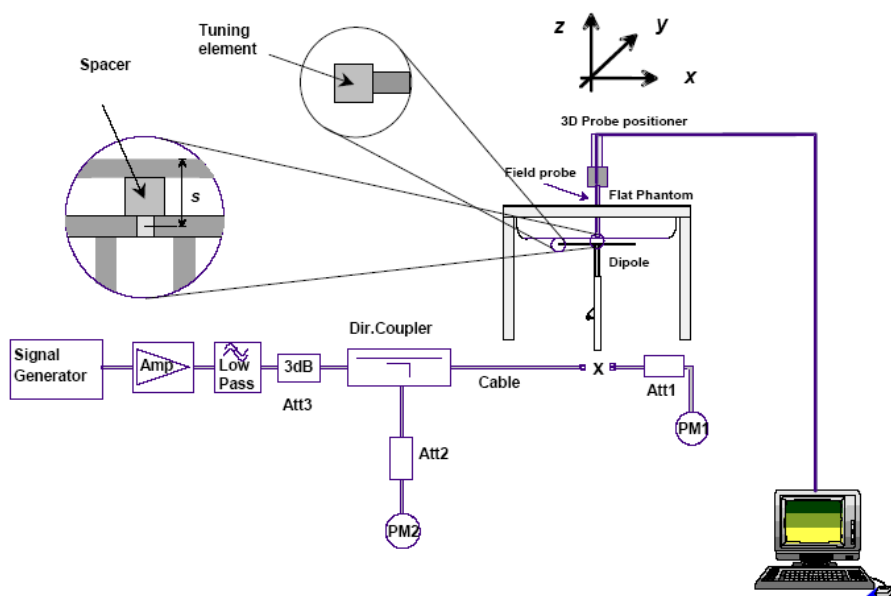

System Accuracy Check Results

Date	Frequency Band	Liquid Type	Input Power (mW)	Measured SAR (W/kg)		Normalized to 1W (W/kg)	Target Value(W/kg)	Delta (%)	Tolerance (%)
				1g	10g				
2018/12/5	2450 MHz	Body	250	1g	12.80	51.2	49.80	2.81	± 10
				10g	5.98	23.92	23.40	2.22	± 10
2018/12/17	5200 MHz	Body	100	1g	7.32	73.2	72.50	0.97	± 10
				10g	2.01	20.10	20.30	-0.99	± 10
2018/12/17	5800 MHz	Body	100	1g	7.40	74.0	74.50	-0.67	± 10
				10g	2.03	20.30	20.70	-1.93	± 10

*The SAR values above are normalized to 1 Watt forward power.

SAR SYSTEM VALIDATION DATA**System Check_Body_2450MHz****DUT: D2450V2-969**

Communication System: CW; Frequency: 2450 MHz; Duty Cycle: 1:1

Medium: MSL2450 Medium parameters used (interpolated): $f = 2450$ MHz; $\sigma = 1.975$ S/m; $\epsilon_r = 53.096$; $\rho = 1000$ kg/m³

DASY5 Configuration:

- Probe: EX3DV4 - SN7520; ConvF(7.48, 7.48, 7.48); Calibrated: 11/5/2018
- Sensor-Surface: 1.4mm (Mechanical Surface Detection)
- Electronics: DAE4 Sn1561; Calibrated: 11/7/2018
- Phantom: ELI-Righr-ELI V8.0 (20deg probe tilt); Type: QD OVA 004 Ax; Serial: 2088
- Measurement SW: DASY52, Version 52.10 (1); SEMCAD X Version 14.6.11 (7437)

Pin=250mW/Area Scan (61x61x1): Interpolated grid: dx=1.200 mm, dy=1.200 mm
Maximum value of SAR (interpolated) = 17.2 W/kg**Pin=250mW/Zoom Scan (7x7x7)/Cube 0:** Measurement grid: dx=5mm, dy=5mm, dz=5mm
Reference Value = 88.56 V/m; Power Drift = 0.02 dB

Peak SAR (extrapolated) = 26.1 W/kg

SAR(1 g) = 12.8 W/kg; SAR(10 g) = 5.98 W/kg

Maximum value of SAR (measured) = 16.9 W/kg

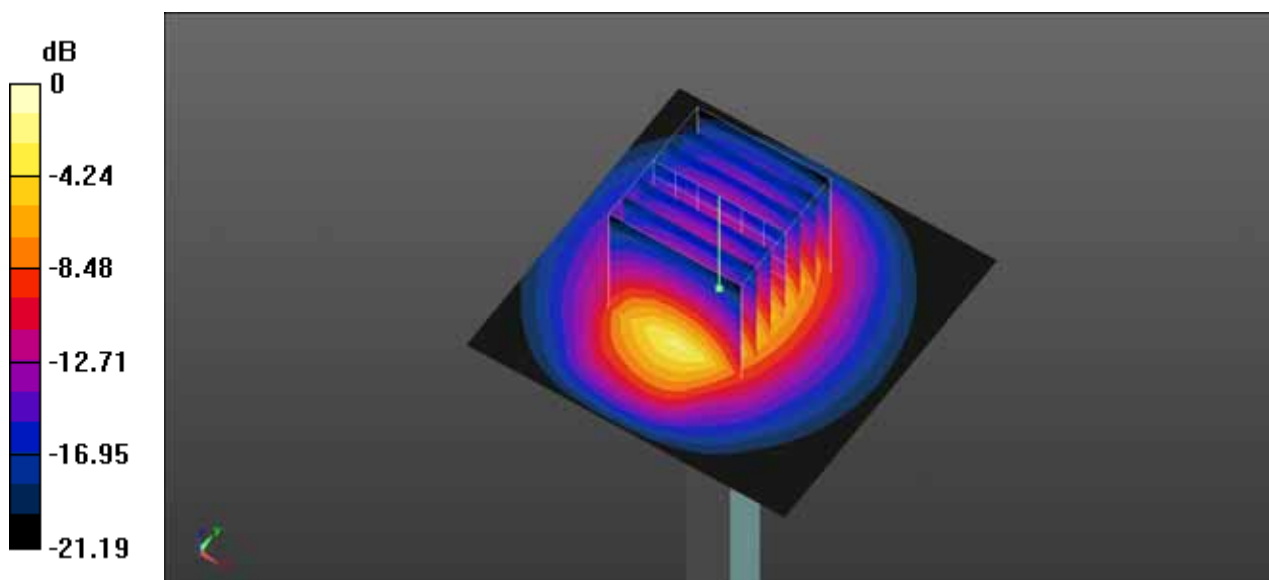

0 dB = 16.9 W/kg = 12.28 dBW/kg

System Check_Body_5200MHz

DUT: D5GHzV2-1225-5200

Communication System: CW; Frequency: 5200 MHz; Duty Cycle: 1:1

Medium: MSL5G Medium parameters used: $f = 5200$ MHz; $\sigma = 5.452$ S/m; $\epsilon_r = 47.038$; $\rho = 1000$ kg/m³

DASY5 Configuration:

- Probe: EX3DV4 - SN7520; ConvF(4.94, 4.94, 4.94); Calibrated: 11/5/2018
- Sensor-Surface: 1.4mm (Mechanical Surface Detection)
- Electronics: DAE4 Sn1561; Calibrated: 11/7/2018
- Phantom: ELI-Righr-ELI V8.0 (20deg probe tilt); Type: QD OVA 004 Ax; Serial: 2088
- Measurement SW: DASY52, Version 52.10 (1); SEMCAD X Version 14.6.11 (7437)

Pin=100mW/Area Scan (71x71x1): Interpolated grid: dx=1.000 mm, dy=1.000 mm
Maximum value of SAR (interpolated) = 17.6 W/kg

Pin=100mW/Zoom Scan (7x7x7)/Cube 0: Measurement grid: dx=4mm, dy=4mm, dz=1.4mm

Reference Value = 66.30 V/m; Power Drift = 0.05 dB

Peak SAR (extrapolated) = 29.1 W/kg

SAR(1 g) = 7.32 W/kg; SAR(10 g) = 2.01 W/kg

Maximum value of SAR (measured) = 17.8 W/kg

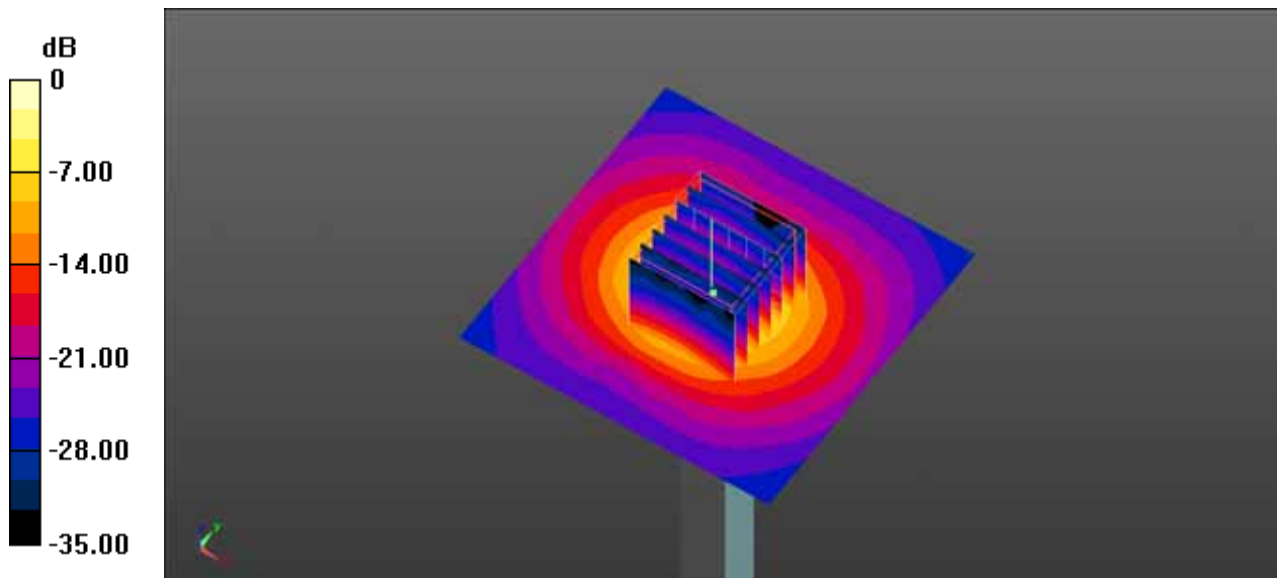

0 dB = 17.8 W/kg = 12.50 dBW/kg

System Check_Body_5800MHz

DUT: D5GHzV2-1225-5800

Communication System: CW; Frequency: 5800 MHz; Duty Cycle: 1:1

Medium: MSL5G Medium parameters used: $f = 5800$ MHz; $\sigma = 6.234$ S/m; $\epsilon_r = 46.02$; $\rho = 1000$ kg/m³

DASY5 Configuration:

- Probe: EX3DV4 - SN7520; ConvF(4.46, 4.46, 4.46); Calibrated: 11/5/2018
- Sensor-Surface: 1.4mm (Mechanical Surface Detection)
- Electronics: DAE4 Sn1561; Calibrated: 11/7/2018
- Phantom: ELI-Righr-ELI V8.0 (20deg probe tilt); Type: QD OVA 004 Ax; Serial: 2088
- Measurement SW: DASY52, Version 52.10 (1); SEMCAD X Version 14.6.11 (7437)

Pin=100mW/Area Scan (71x71x1): Interpolated grid: dx=1.000 mm, dy=1.000 mm
 Maximum value of SAR (interpolated) = 18.7 W/kg

Pin=100mW/Zoom Scan (7x7x7)/Cube 0: Measurement grid: dx=4mm, dy=4mm, dz=1.4mm

Reference Value = 61.10 V/m; Power Drift = 0.05 dB

Peak SAR (extrapolated) = 32.3 W/kg

SAR(1 g) = 7.4 W/kg; SAR(10 g) = 2.03 W/kg

Maximum value of SAR (measured) = 18.9 W/kg

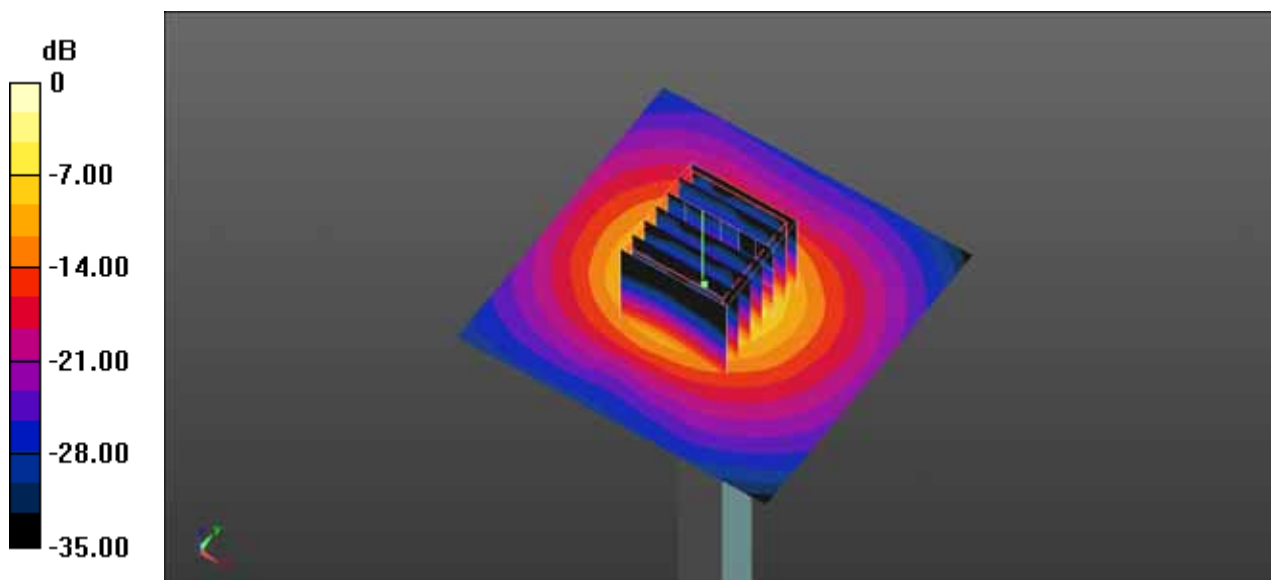

0 dB = 18.9 W/kg = 12.76 dBW/kg

EUT TEST STRATEGY AND METHODOLOGY

Test Positions for Device Operating Next to a Person’s Ear

This category includes most wireless handsets with fixed, retractable or internal antennas located toward the top half of the device, with or without a foldout, sliding or similar keypad cover. The handset should have its earpiece located within the upper ¼ of the device, either along the centerline or off-centered, as perceived by its users. This type of handset should be positioned in a normal operating position with the “test device reference point” located along the “vertical centerline” on the front of the device aligned to the “ear reference point”. The “test device reference point” should be located at the same level as the center of the earpiece region. The “vertical centerline” should bisect the front surface of the handset at its top and bottom edges. A “ear reference point” is located on the outer surface of the head phantom on each ear spacer. It is located 1.5 cm above the center of the ear canal entrance in the “phantom reference plane” defined by the three lines joining the center of each “ear reference point” (left and right) and the tip of the mouth.

A handset should be initially positioned with the earpiece region pressed against the ear spacer of a head phantom. For the SCC-34/SC-2 head phantom, the device should be positioned parallel to the “N-F” line defined along the base of the ear spacer that contains the “ear reference point”. For interim head phantoms, the device should be positioned parallel to the cheek for maximum RF energy coupling. The “test device reference point” is aligned to the “ear reference point” on the head phantom and the “vertical centerline” is aligned to the “phantom reference plane”. This is called the “initial ear position”. While maintaining these three alignments, the body of the handset is gradually adjusted to each of the following positions for evaluating SAR:

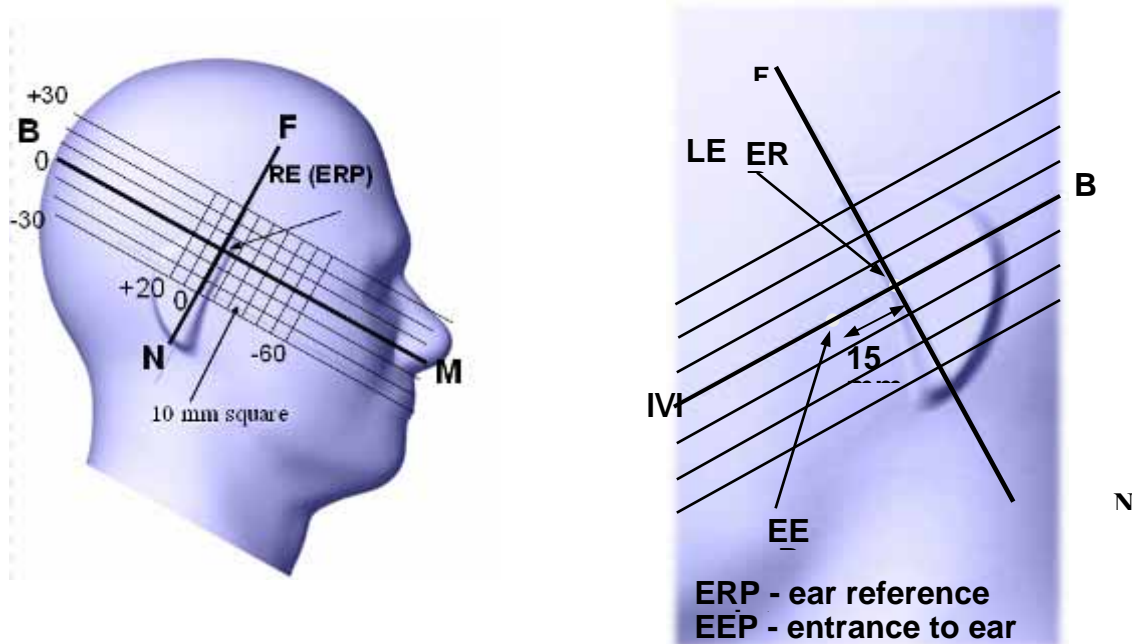

Cheek/Touch Position

The device is brought toward the mouth of the head phantom by pivoting against the “ear reference point” or along the “N-F” line for the SCC-34/SC-2 head phantom.

This test position is established:

When any point on the display, keypad or mouthpiece portions of the handset is in contact with the phantom.

(or) When any portion of a foldout, sliding or similar keypad cover opened to its intended self-adjusting normal use position is in contact with the cheek or mouth of the phantom.

For existing head phantoms – when the handset loses contact with the phantom at the pivoting point, rotation should continue until the device touches the cheek of the phantom or breaks its last contact from the ear spacer.

Cheek /Touch Position

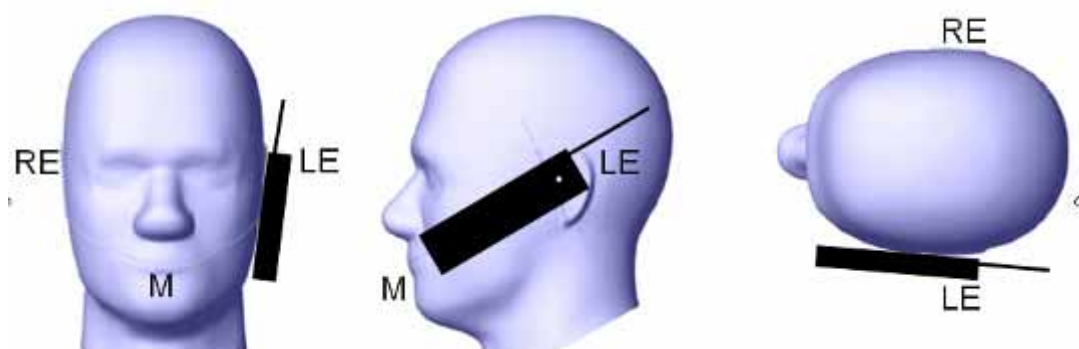

Ear/Tilt Position

With the handset aligned in the “Cheek/Touch Position”:

1) If the earpiece of the handset is not in full contact with the phantom’s ear spacer (in the “Cheek/Touch position”) and the peak SAR location for the “Cheek/Touch” position is located at the ear spacer region or corresponds to the earpiece region of the handset, the device should be returned to the “initial ear position” by rotating it away from the mouth until the earpiece is in full contact with the ear spacer.

2) (otherwise) The handset should be moved (translated) away from the cheek perpendicular to the line passes through both “ear reference points” (note: one of these ear reference points may not physically exist on a split head model) for approximate 2-3 cm. While it is in this position, the device handset is tilted away from the mouth with respect to the “test device reference point” until the inside angle between the vertical centerline on the front surface of the phone and the horizontal line passing through the ear reference point is by 15° to 80° . After the tilt, it is then moved (translated) back toward the head perpendicular to the line passes through both “ear reference points” until the device touches the phantom or the ear spacer. If the antenna touches the head first, the positioning process should be repeated with a tilt angle less than 15° so that the device and its antenna would touch the phantom simultaneously. This test position may require a device holder or positioner to achieve the translation and tilting with acceptable positioning repeatability.

If a device is also designed to transmit with its keypad cover closed for operating in the head position, such positions should also be considered in the SAR evaluation. The device should be tested on the left and right side of the head phantom in the “Cheek/Touch” and “Ear/Tilt” positions. When applicable, each configuration should be tested with the antenna in its fully extended and fully retracted positions. These test configurations should be tested at the high, middle and low frequency channels of each operating mode; for example, AMPS, CDMA, and TDMA. If the SAR measured at the middle channel for each test configuration (left, right, Cheek/Touch, Tilt/Ear, extended and retracted) is at least 2.0 dB lower than the SAR limit, testing at the high and low channels is optional for such test configuration(s). If the transmission band of the test device is less than 10 MHz, testing at the high and low frequency channels is optional.

Ear /Tilt 15° Position

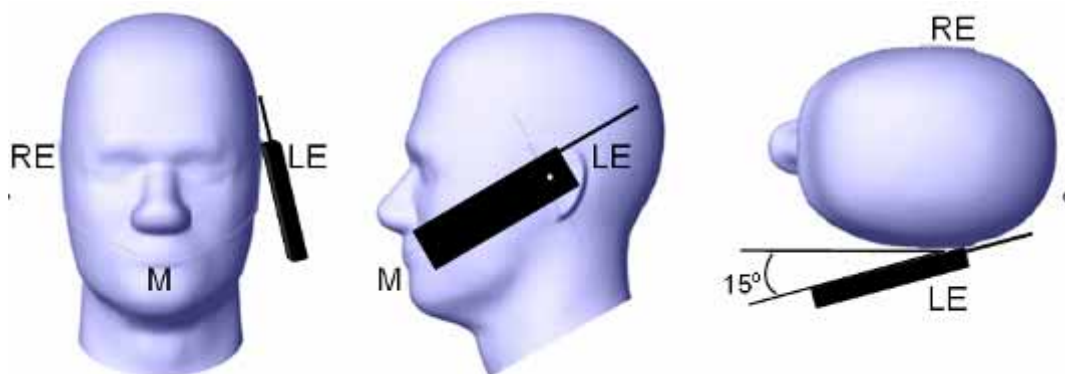

Test positions for body-worn and other configurations

Body-worn operating configurations should be tested with the belt-clips and holsters attached to the device and positioned against a flat phantom in normal use configurations. Devices with a headset output should be tested with a headset connected to the device. When multiple accessories that do not contain metallic components are supplied with the device, the device may be tested with only the accessory that dictates the closest spacing to the body. When multiple accessories that contain metallic components are supplied with the device, the device must be tested with each accessory that contains a unique metallic component. If multiple accessories share an identical metallic component (e.g., the same metallic belt-clip used with different holsters with no other metallic components), only the accessory that dictates the closest spacing to the body must be tested.

Body-worn accessories may not always be supplied or available as options for some devices that are intended to be authorized for body-worn use. A separation distance of 1.5 cm between the back of the device and a flat phantom is recommended for testing body-worn SAR compliance under such circumstances. Other separation distances may be used, but they should not exceed 2.5 cm. In these cases, the device may use body-worn accessories that provide a separation distance greater than that tested for the device provided however that the accessory contains no metallic components.

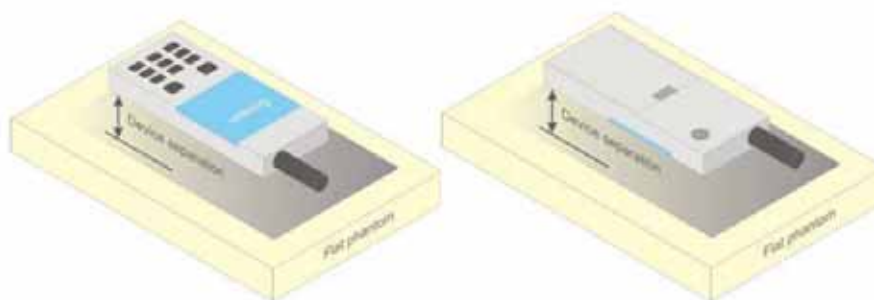

Figure 5 – Test positions for body-worn devices

Test Distance for SAR Evaluation

For this case the EUT(Equipment Under Test) is set 10mm away from the phantom, the test distance is 10mm.

SAR Evaluation Procedure

The evaluation was performed with the following procedure:

Step 1: Measurement of the SAR value at a fixed location above the ear point or central position was used as a reference value for assessing the power drop. The SAR at this point is measured at the start of the test and then again at the end of the testing.

Step 2: The SAR distribution at the exposed side of the head was measured at a distance of 4 mm from the inner surface of the shell. The area covered the entire dimension of the head or radiating structures of the EUT, the horizontal grid spacing was 15 mm x 15 mm, and the SAR distribution was determined by integrated grid of 1.5mm x 1.5mm. Based on these data, the area of the maximum absorption was determined by spline interpolation. The first Area Scan covers the entire dimension of the EUT to ensure that the hotspot was correctly identified.

Step 3: Around this point, a volume of 30 mm x 30 mm x 30 mm was assessed by measuring 7x 7 x 7 points. On the basis of this data set, the spatial peak SAR value was evaluated under the following procedure:

- 1) The data at the surface were extrapolated, since the center of the dipoles is 1.2 mm away from the tip of the probe and the distance between the surface and the lowest measuring point is 1.3 mm. The extrapolation was based on a least square algorithm. A polynomial of the fourth order was calculated through the points in z-axes. This polynomial was then used to evaluate the points between the surface and the probe tip.

- 2) The maximum interpolated value was searched with a straightforward algorithm. Around this maximum the SAR values averaged over the spatial volumes (1 g or 10 g) were computed by the 3D-Spline interpolation algorithm. The 3D-Spline is composed of three one dimensional splines with the "Not a knot"-condition (in x, y and z-directions). The volume was integrated with the trapezoidal-algorithm. One thousand points (10 x 10 x 10) were interpolated to calculate the averages.

All neighboring volumes were evaluated until no neighboring volume with a higher average value was found.

Step 4: Re-measurement of the SAR value at the same location as in Step 1. If the value changed by more than 5%, the evaluation was repeated.

CONDUCTED OUTPUT POWER MEASUREMENT

Provision Applicable

The measured peak output power should be greater and within 5% than EMI measurement.

Test Procedure

The RF output of the transmitter was connected to the input of the Signal Analyzer through Connector.

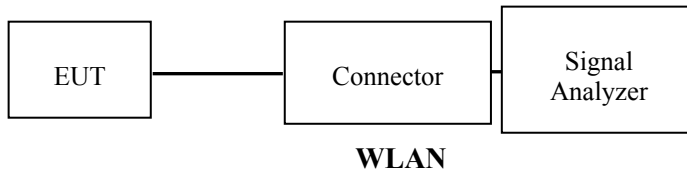

The RF output of the transmitter was connected to the input of the EMI Test Receiver through sufficient attenuation.

Radio Configuration

The power measurement was configured by the Wireless Communication Test Set.

Maximum Target Output Power

WLAN 2.4GHz:

Test mode	Channel	Tune-Up Power (dBm)
802.11b	Low	17.0
	Middle	17.0
	High	17.0
802.11g	Low	14.0
	Middle	14.0
	High	14.0
802.11n-HT20	Low	14.0
	Middle	14.0
	High	14.0

WLAN 5GHz:

Test mode	Band	Channel	Tune-Up Power (dBm)
802.11a	5150-5250 MHz	Low	22.50
		Middle	22.0
		High	21.0
	5725-5850 MHz	Low	20.5
		Middle	22.5
		High	25.0
802.11n-HT20	5150-5250 MHz	Low	22.50
		Middle	22.00
		High	21.05
	5725-5850 MHz	Low	21.0
		Middle	23.0
		High	25.5

Test Results:

WLAN 2.4GHz:

Test mode	Channel	Frequency (MHz)	Max Conducted Average Power (dBm)	Tune-Up Power (dBm)
802.11b	Low	2412	16.77	17.0
	Middle	2437	16.86	17.0
	High	2462	16.66	17.0
802.11g	Low	2412	13.36	14.0
	Middle	2437	13.31	14.0
	High	2462	13.18	14.0
802.11n-HT20	Low	2422	13.57	14.0
	Middle	2437	13.63	14.0
	High	2452	13.42	14.0

WLAN 5GHz:

Test mode	Band	Channel	Frequency (MHz)	Average Conducted Output Power (dBm)	Tune-Up Power (dBm)
802.11a	5150-5250 MHz	Low	5180	22.25	22.50
		Middle	5200	21.56	22.00
		High	5240	20.92	21.50
	5725-5850 MHz	Low	5745	20.19	20.50
		Middle	5785	22.09	22.50
		High	5825	24.65	25.00
802.11n-HT20	5150-5250 MHz	Low	5180	22.25	22.50
		Middle	5200	21.67	22.00
		High	5240	21.02	21.05
	5725-5850 MHz	Low	5745	20.91	21.00
		Middle	5785	22.72	23.00
		High	5825	25.04	25.50

Standalone SAR test exclusion considerations

Antennas Location:

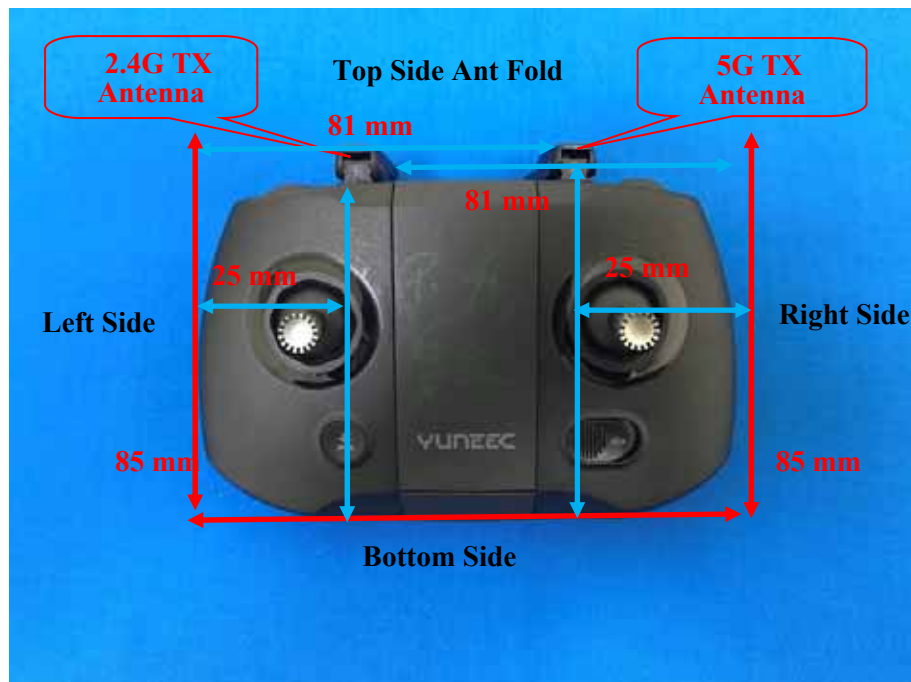

Antenna Distance To Edge

Antenna Distance To Edge(mm)						
Antenna	Front	Back	Right Side	Left Side	Top Side Ant Fold	Bottom Side
WLAN 2.4G	<5	<5	81	25	<5	85
WLAN 5G	<5	<5	25	81	<5	85

Standalone SAR test exclusion for the EUT Edge considerations (KDB)

Test exclusion result						
Antenna	Front	Back	Right Side	Left Side	Top Side Ant Fold	Bottom Side
WLAN 2.4G	Required	Required	Exclusion	Required	Required	Exclusion
WLAN 5G	Required	Required	Required	Exclusion	Required	Exclusion

Note:

Required: Per KDB 941225 D07: The distance to Edge is less than 25mm, test is required.

Exclusion: Per KDB 941225 D07: The distance to Edge is more than 25mm, test is not required.

SAR MEASUREMENT RESULTS

This page summarizes the results of the performed dosimetric evaluation.

SAR Test Data

Environmental Conditions

Temperature:	22.3-22.6 °C	22.3-22.9 °C
Relative Humidity:	47 %	45 %
ATM Pressure:	99.1 kPa	99.6 kPa
Test Date:	2018/12/5	2018/12/17

Testing was performed by Angelo Chang

WLAN 2.4G:

Plot No.	Mode	Test Position	Gap (mm)	Ch.	Freq. (MHz)	Average Power (dBm)	Tune-Up Power (dBm)	Power Drift (dB)	Measured 10g SAR (W/kg)	Reported 10g SAR (W/kg)	Corrected SAR
1	802.11b 1Mbps	Top Side Ant Fold	0	6	2437	16.86	17	0.12	1.230	1.270	1.27
2	802.11b 1Mbps	Left Side	0	6	2437	16.86	17	-0.04	0.203	0.210	0.21
3	802.11b 1Mbps	Front	0	6	2437	16.86	17	-0.12	0.040	0.041	0.05
4	802.11b 1Mbps	Back	0	6	2437	16.86	17	-0.11	0.798	0.824	0.83
5	802.11b 1Mbps	Top Side Ant Fold	0	1	2412	16.77	17	-0.13	1.060	1.118	1.12
6	802.11b 1Mbps	Top Side Ant Fold	0	11	2462	16.66	17	0.09	1.370	1.482	1.49

Plot No.	Mode	Test Position	Gap (mm)	Ch.	Freq. (MHz)	Average Power (dBm)	Tune-Up Power (dBm)	Power Drift (dB)	Measured 1g SAR (W/kg)	Reported 1g SAR (W/kg)	Corrected SAR
19	802.11b 1Mbps	Top Side Ant Fold	10	6	2437	16.86	17	-0.11	1.110	1.146	1.15
20	802.11b 1Mbps	Left Side	10	6	2437	16.86	17	-0.17	0.305	0.315	0.32
21	802.11b 1Mbps	Front	10	6	2437	16.86	17	-0.04	0.051	0.053	0.06
22	802.11b 1Mbps	Back	10	6	2437	16.86	17	-0.1	0.622	0.642	0.65
23	802.11b 1Mbps	Top Side Ant Fold	10	1	2412	16.77	17	-0.16	0.708	0.747	0.75
24	802.11b 1Mbps	Top Side Ant Fold	10	11	2462	16.66	17	-0.18	1.100	1.190	1.19

WLAN 5G :

Plot No.	Mode	Test Position	Gap (mm)	Ch.	Freq. (MHz)	Average Power (dBm)	Tune-Up Power (dBm)	Power Drift (dB)	Measured 1g SAR (W/kg)	Reported 1g SAR (W/kg)	Corrected SAR
25	802.11a 6Mbps	Top Side Ant Fold	10	36	5180	22.25	22.50	0.08	1.130	1.197	1.20
26	802.11a 6Mbps	Right Side	10	36	5180	22.25	22.50	-0.07	0.114	0.121	0.13
27	802.11a 6Mbps	Front	10	36	5180	22.25	22.50	-0.12	0.197	0.209	0.21
28	802.11a 6Mbps	Back	10	36	5180	22.25	22.50	0.06	0.882	0.934	0.94
29	802.11a 6Mbps	Top Side Ant Fold	10	40	5200	21.56	22.00	0.19	1.110	1.228	1.23
30	802.11a 6Mbps	Top Side Ant Fold	10	48	5240	20.92	21.50	-0.02	1.090	1.246	1.25
31	802.11a 6Mbps	Back	10	40	5200	21.56	22.00	0.08	0.872	0.965	0.97
32	802.11a 6Mbps	Back	10	48	5240	20.92	21.50	0.12	0.902	1.031	1.04
33	802.11n-HT20 MCS0	Top Side Ant Fold	10	165	5825	25.04	25.50	0.09	1.090	1.212	1.22
34	802.11n-HT20 MCS0	Right Side	10	165	5825	25.04	25.50	-0.1	0.103	0.115	0.12
35	802.11n-HT20 MCS0	Front	10	165	5825	25.04	25.50	-0.17	0.324	0.360	0.36
36	802.11n-HT20 MCS0	Back	10	165	5825	25.04	25.50	-0.19	0.974	1.083	1.09
37	802.11n-HT20 MCS0	Top Side Ant Fold	10	149	5745	20.91	21.00	-0.13	0.837	0.855	0.86
38	802.11n-HT20 MCS0	Top Side Ant Fold	10	157	5785	22.72	23.00	-0.11	1.120	1.195	1.20
39	802.11n-HT20 MCS0	Back	10	149	5745	20.91	21.00	-0.12	0.955	0.975	0.98
40	802.11n-HT20 MCS0	Back	10	157	5785	22.72	23.00	-0.09	0.997	1.063	1.07

Plot No.	Mode	Test Position	Gap (mm)	Ch.	Freq. (MHz)	Average Power (dBm)	Tune-Up Power (dBm)	Power Drift (dB)	Measured 10g SAR (W/kg)	Reported 10g SAR (W/kg)	Corrected SAR
7	802.11a 6Mbps	Top Side Ant Fold	0	36	5180	22.25	22.50	0.14	1.680	1.680	1.68
8	802.11a 6Mbps	Right Side	0	36	5180	22.25	22.50	0.17	0.091	0.096	0.10
9	802.11a 6Mbps	Front	0	36	5180	22.25	22.50	-0.13	0.339	0.359	0.36
10	802.11a 6Mbps	Back	0	36	5180	22.25	22.50	-0.08	0.252	0.267	0.27
11	802.11a 6Mbps	Top Side Ant Fold	0	40	5200	21.56	22.00	-0.04	1.600	1.771	1.78
12	802.11a 6Mbps	Top Side Ant Fold	0	48	5240	20.92	21.50	-0.19	1.610	1.840	1.84
13	802.11n-HT20 MCS0	Top Side Ant Fold	0	165	5825	25.04	25.50	-0.17	1.410	1.568	1.57
14	802.11n-HT20 MCS0	Right Side	0	165	5825	25.04	25.50	0.18	0.084	0.093	0.10
15	802.11n-HT20 MCS0	Front	0	165	5825	25.04	25.50	0.13	0.143	0.159	0.16
16	802.11n-HT20 MCS0	Back	0	165	5825	25.04	25.50	-0.06	0.174	0.193	0.20
17	802.11n-HT20 MCS0	Top Side Ant Fold	0	149	5745	20.91	21.00	-0.14	1.200	1.225	1.23
18	802.11n-HT20 MCS0	Top Side Ant Fold	0	157	5785	22.72	23.00	-0.19	1.460	1.557	1.56

Note:

1. When the SAR value is less than half of the limit, testing for other channels are optional.
2. When SAR or MPE is not measured at the maximum power level allowed for production to the individual channels tested to determine compliance.
3. According to Notice 2016-DRS001: Based on the IEEE 1528 and IEC 62209 requirements, the high, mid and low channels for the configuration with the highest SAR value must be tested regardless of the SAR value measured
4. According to Notice 2012-DRS0529, if the correction SAR has a negative sign, the measured SAR result should be corrected, and has a positive sign, the measured SAR result shall not be corrected.
5. Per KDB 248227 D01 SAR when multiple transmission modes (802.11a/g/n/ac) have the same specified maximum output power, largest channel bandwidth, lowest order modulation and lowest data rate, lowest order 802.11 mode is selected (i.e. a, g, n, then ac).

Corrected SAR Evaluation

62209-2 © IEC:2010

– 89 –

Annex F
(normative)**SAR correction for deviations of complex permittivity from targets****F.2 SAR correction formula**

From [13] and [14], a linear relationship was found between the percent change in SAR (denoted ΔSAR) and the percent change in the permittivity and conductivity from the target values in Table 1 (denoted $\Delta \epsilon_r$ and $\Delta \sigma$, respectively). This linear relationship agrees with the results of Kuster and Balzano [48] and Bit-Babik et al. [2]. The relationship is given by:

$$\Delta SAR = c_\epsilon \Delta \epsilon_r + c_\sigma \Delta \sigma \quad (F.1)$$

where

$c_\epsilon = \partial(\Delta SAR)/\partial(\Delta \epsilon)$ is the coefficients representing the sensitivity of SAR to permittivity where SAR is normalized to output power;

$c_\sigma = \partial(\Delta SAR)/\partial(\Delta \sigma)$ is the coefficients representing the sensitivity of SAR to conductivity, where SAR is normalized to output power.

The values of c_ϵ and c_σ have a simple relationship with frequency that can be described using polynomial equations. For the 1 g averaged SAR c_ϵ and c_σ are given by

$$c_\epsilon = -7,854 \times 10^{-4} f^3 + 9,402 \times 10^{-3} f^2 - 2,742 \times 10^{-2} f - 0,202 \ 6 \quad (F.2)$$

$$c_\sigma = 9,804 \times 10^{-3} f^3 - 8,661 \times 10^{-2} f^2 + 2,981 \times 10^{-2} f + 0,782 \ 9 \quad (F.3)$$

where

f is the frequency in GHz.

For the 10 g averaged SAR, the variables c_ϵ and c_σ are given by:

$$c_\epsilon = 3,456 \times 10^{-3} f^3 - 3,531 \times 10^{-2} f^2 + 7,675 \times 10^{-2} f - 0,186 \ 0 \quad (F.4)$$

$$c_\sigma = 4,479 \times 10^{-3} f^3 - 1,586 \times 10^{-2} f^2 - 0,197 \ 2 f + 0,771 \ 7 \quad (F.5)$$

Corrected SAR Evaluation Table :**1g**

Frequency (MHz)	Liquid Type	C ϵ	r	C δ		SAR (%)
2412	Body	-0.225	0.83	0.489	0.73	0.17
2437	Body	-0.225	0.84	0.483	0.93	0.26
2462	Body	-0.225	0.65	0.478	1.07	0.36

10g

Frequency (MHz)	Liquid Type	C ϵ	r	C δ		SAR (%)
2412	Body	-0.158	0.83	0.267	0.73	0.33
2437	Body	-0.159	0.84	0.262	0.93	0.47
2462	Body	-0.159	0.65	0.257	1.07	0.47

*Test Date 2018-12-05.

1g

Frequency (MHz)	Liquid Type	C ϵ	r	C δ		SAR (%)
5180	Body	-0.202	-3.96	-0.024	2.78	0.73
5200	Body	-0.201	-4.00	-0.026	2.87	0.73
5240	Body	-0.201	-4.13	-0.028	2.82	0.75
5745	Body	-0.199	-4.49	-0.045	3.84	0.72
5785	Body	-0.199	-4.42	-0.045	3.85	0.70
5825	Body	-0.199	-4.59	-0.044	4.57	0.71

10g

Frequency (MHz)	Liquid Type	C ϵ	r	C δ		SAR (%)
5180	Body	-0.256	-3.96	-0.053	2.78	-0.01
5200	Body	-0.256	-4.00	-0.053	2.87	-0.01
5240	Body	-0.256	-4.13	-0.053	2.82	0.00
5745	Body	-0.255	-4.49	-0.035	3.84	0.72
5785	Body	-0.255	-4.42	-0.033	3.85	0.73
5825	Body	-0.254	-4.59	-0.030	4.57	0.74

*Test Date 2018-12-17.

SAR Measurement Variability

In accordance with published RF Exposure KDB procedure 865664 D01 SAR measurement 100 MHz to 6 GHz v01. These additional measurements are repeated after the completion of all measurements requiring the same head or body tissue-equivalent medium in a frequency band. The test device should be returned to ambient conditions (normal room temperature) with the battery fully charged before it is re-mounted on the device holder for the repeated measurement(s) to minimize any unexpected variations in the repeated results

- 1) Repeated measurement is not required when the original highest measured SAR is < 0.80 W/kg; steps 2) through 4) do not apply.
- 2) When the original highest measured SAR is ≥ 0.80 W/kg, repeat that measurement once.
- 3) Perform a second repeated measurement only if the ratio of largest to smallest SAR for the original and first repeated measurements is > 1.20 or when the original or repeated measurement is ≥ 1.45 W/kg (~ 10% from the 1-g SAR limit).
- 4) Perform a third repeated measurement only if the original, first or second repeated measurement is ≥ 1.5 W/kg and the ratio of largest to smallest SAR for the original, first and second repeated measurements is > 1.20 .

Note: The same procedures should be adapted for measurements according to extremity and occupational exposure limits by applying a factor of 2.5 for extremity exposure and a factor of 5 for occupational exposure to the corresponding SAR thresholds.

The Highest Measured SAR Configuration in Each Frequency Band

1g:

Frequency Band	Freq.(MHz)	EUT Position	Meas. SAR (W/kg)		Largest to Smallest SAR Ratio
			Original	Repeated	
WLAN 2.4G	2462	Top Side Ant Fold	1.11	1.09	1.02
WLAN 5G	5180	Top Side Ant Fold	1.13	1.05	1.08

10g:

Frequency Band	Freq.(MHz)	EUT Position	Meas. SAR (W/kg)		Largest to Smallest SAR Ratio
			Original	Repeated	
WLAN 2.4G	2462	Top Side Ant Fold	1.37	1.31	1.05
WLAN 5G	5180	Top Side Ant Fold	1.68	1.59	1.06

Note:

1. Second Repeated Measurement is not required since the ratio of the largest to smallest SAR for the original and first repeated measurement is not > 1.20 .
2. The measured SAR results **do not** have to be scaled to the maximum tune-up tolerance to determine if repeated measurements are required.
3. SAR measurement variability must be assessed for each frequency band, which is determined by the **SAR probe calibration point and tissue-equivalent medium** used for the device measurements..
4. While 1-g SAR thresholds are specified in the procedures for SAR test reduction and exclusion, these thresholds should be multiplied by 2.5 when 10-g extremity SAR is considered.

SAR SIMULTANEOUS TRANSMISSION DESCRIPTION

Simultaneous Transmission:

Description of Simultaneous Transmit Capabilities		
Transmitter Combination	Simultaneous?	Hotspot?
-	X	X

Simultaneous and Hotspot SAR test exclusion considerations:

Mode(SAR1+SAR2)	Position	Reported SAR(W/kg)		ΣSAR < 1.6W/kg
		SAR1	SAR2	
-	-	-	-	-
	-	-	-	-
	-	-	-	-
	-	-	-	-
	-	-	-	-
	-	-	-	-
-	-	-	-	-
	-	-	-	-
	-	-	-	-
	-	-	-	-
	-	-	-	-
	-	-	-	-
-	-	-	-	-
	-	-	-	-
	-	-	-	-
	-	-	-	-
	-	-	-	-
	-	-	-	-

Conclusion:

Sum of SAR: ΣSAR ≤ 1.6 W/kg therefore simultaneous transmission SAR with Volume Scans is **not required**.

APPENDIX A MEASUREMENT UNCERTAINTY

The uncertainty budget has been determined for the measurement system and is given in the following Table.

Measurement uncertainty evaluation for IEEE1528-2013 SAR test

Source of uncertainty	Tolerance/uncertainty ± %	Probability distribution	Divisor	ci (1 g)	ci (10 g)	Standard uncertainty ± %, (1 g)	Standard uncertainty ± %, (10 g)
Measurement system							
Probe calibration	6.55	N	1	1	1	6.6	6.6
Axial Isotropy	4.7	R	√3	1	1	2.7	2.7
Hemispherical Isotropy	9.6	R	√3	0	0	0.0	0.0
Boundary effect	1.0	R	√3	1	1	0.6	0.6
Linearity	4.7	R	√3	1	1	2.7	2.7
Detection limits	1.0	R	√3	1	1	0.6	0.6
Readout electronics	0.3	N	1	1	1	0.3	0.3
Response time	0.0	R	√3	1	1	0.0	0.0
Integration time	0.0	R	√3	1	1	0.0	0.0
RF ambient conditions – noise	1.0	R	√3	1	1	0.6	0.6
RF ambient conditions–reflections	1.0	R	√3	1	1	0.6	0.6
Probe positioner mech. Restrictions	0.8	R	√3	1	1	0.5	0.5
Probe positioning with respect to phantom shell	6.7	R	√3	1	1	3.9	3.9
Post-processing	2.0	R	√3	1	1	1.2	1.2
Test sample related							
Test sample positioning	2.8	N	1	1	1	2.8	2.8
Device holder uncertainty	6.3	N	1	1	1	6.3	6.3
Drift of output power	5.0	R	√3	1	1	2.9	2.9
Phantom and set-up							
Phantom uncertainty (shape and thickness tolerances)	4.0	R	√3	1	1	2.3	2.3
Liquid conductivity target)	5.0	R	√3	0.64	0.43	1.8	1.2
Liquid conductivity meas.)	2.5	N	1	0.64	0.43	1.6	1.1
Liquid permittivity target)	5.0	R	√3	0.6	0.49	1.7	1.4
Liquid permittivity meas.)	2.5	N	1	0.6	0.49	1.5	1.2
Combined standard uncertainty		RSS				12.2	12.0
Expanded uncertainty 95 % confidence interval)						24.3	23.9

Measurement uncertainty evaluation for IEC62209-2 SAR test

Source of uncertainty	Tolerance/uncertainty ± %	Probability distribution	Divisor	ci (1 g)	ci (10 g)	Standard uncertainty ± %, (1 g)	Standard uncertainty ± %, (10 g)
Measurement system							
Probe calibration	6.55	N	1	1	1	6.6	6.6
Axial Isotropy	4.7	R	√3	1	1	2.7	2.7
Hemispherical Isotropy	9.6	R	√3	0	0	0.0	0.0
Linearity	4.7	R	√3	1	1	2.7	2.7
Modulation Response	0.0	R	√3	1	1	0.0	0.0
Detection limits	1.0	R	√3	1	1	0.6	0.6
Boundary effect	1.0	R	√3	1	1	0.6	0.6
Readout electronics	0.3	N	1	1	1	0.3	0.3
Response time	0.0	R	√3	1	1	0.0	0.0
Integration time	0.0	R	√3	1	1	0.0	0.0
RF ambient conditions – noise	1.0	R	√3	1	1	0.6	0.6
RF ambient conditions–reflections	1.0	R	√3	1	1	0.6	0.6
Probe positioner mech. Restrictions	0.8	R	√3	1	1	0.5	0.5
Probe positioning with respect to phantom shell	6.7	R	√3	1	1	3.9	3.9
Post-processing	2.0	R	√3	1	1	1.2	1.2
Test sample related							
Device holder Uncertainty	6.3	N	1	1	1	6.3	6.3
Test sample positioning	2.8	N	1	1	1	2.8	2.8
Power scaling	4.5	R	√3	1	1	2.6	2.6
Drift of output power	5.0	R	√3	1	1	2.9	2.9
Phantom and set-up							
Phantom uncertainty (shape and thickness tolerances)	4.0	R	√3	1	1	2.3	2.3
Algorithm for correcting SAR for deviations in permittivity and conductivity	1.9	N	1	1	0.84	1.1	0.9
Liquid conductivity (meas.)	2.5	N	1	0.64	0.43	1.6	1.1
Liquid permittivity (meas.)	2.5	N	1	0.6	0.49	1.5	1.2
Temp. unc. - Conductivity	1.7	R	√3	0.78	0.71	0.8	0.7
Temp. unc. - Permittivity	0.3	R	√3	0.23	0.26	0.0	0.0
Combined standard uncertainty		RSS				12.2	12.1
Expanded uncertainty 95 % confidence interval)						24.5	24.2

APPENDIX B EUT TEST POSITION PHOTOS

Please refer to the file document of RXZ181211002-23A

APPENDIX B EUT TEST POSITION PHOTOS

APPENDIX C SAR PLOTS OF SAR MEASUREMENT

Please refer to the file document of RXZ181211002-23A

APPENDIX C SAR PLOTS OF SAR MEASUREMENT.

APPENDIX D CALIBRATION CERTIFICATES

Please refer to the file document of RXZ181211002-23A

APPENDIX D CALIBRATION CERTIFICATES.

***** END OF REPORT *****