

Mantis G

USER MANUAL V1.0

YUNEEC

CONTENT

Introduction	04
Specifications	04
-Aircraft	04
-Remote Controller	05
-Mobile Device Control	05
-APP	05
-Camera	05
Overview	07
-Aircraft	07
-Remote Controller	07
Charging the Remote Controller	08
Preparing the Aircraft	08
Charging the Flight Battery	08
SD Card Installation	09
Installing the Smart Device	09
Powering ON/OFF	09
Binding	10
-Scan QR Code	10
-Manual Connection	11
Compass Calibration	12
Placement Before Takeoff	14
Take Off	14
-Auto Take-off	14
-Manual Take-off	14
Direction Control	15
Optimal Transmission Zone	15
Taking Photos and Recording Videos	16
-To Take a Still Photo	16
-To Start/Stop Recording Video	16
-Camera Tilt Control	16
Voice Control	16
Instant Social Sharing	17

Flight Modes	18
-Angle Mode	18
-Sport Mode	18
Advanced Functions	18
-Journey	18
-POI	19
-Visual Tracking	19
Return to Home	19
-Smart RTH	19
-Low Battery RTH	20
-Failsafe RTH	20
Landing	20
-Auto Land	20
-Manual Land	20
LED Status Indication	21
Firmware Update	22
Disclaimer	22
Collection and Processing of Data	23
Battery Warnings and Usage Guidelines	23
General Safety Precautions and Warnings	24
Camera Usage Warnings	25
FCC Statement	25
RF Exposure Warning	26
IC Radiation Exposure Statement for Canada	26
NCC Warning Statement	26
CE Warning Statement	26
EU Compliance Statement	26
Customer Service	27

INTRODUCTION

Mantis G – the foldable and convenient travel drone for small and big adventures alike. It listens to you thanks to voice control, and the visual tracking will let it follow you wherever you go. Whether you're backpacking in Thailand, on a road trip through the South or with your family at the beach, Mantis G's energy-efficient design keeps in the air for up to 33 minutes. The Mantis takes pictures with a resolution of 13MP and saves them on the included MicroSD card; the same goes for the 4K recorded videos. The integrated camera can be tilted up to 20° upwards and 90° downwards during flight. For cinematic camera flights, we also equipped the Mantis with automatic advanced functions such as Journey or POI.

SPECIFICATIONS

AIRCRAFT	
Product Name	Mantis G
Model	YUNMGA
Max Takeoff Weight	16.9oz (480g)
Max Flight Time	33mins (in no wind environment with speed of 15.5mph)
Dimensions	folded: 6.6x3.8x2.2in (168x96x58mm) (LxWxH) unfolded: 9.8x7.4x2.2in (250x187x58mm) (LxWxH)
Diagonal Size (Propellers Excluded)	10.7in (270mm)
Propeller Size	6.1in (155mm)
Max Ascent Speed	Angle/Manual Mode: 6.7mph (3m/s) Sport: 8.9mph (4m/s) IPS Mode: 2.2mph (1m/s) Phone Mode: 4.5 mph (2m/s)
Max Descent Speed	Angle/Manual Mode: 4.5 mph (2m/s) Sport Mode: 6.7mph (3m/s) IPS/ Phone Mode: 2.2mph (1m/s)
Max Speed	Angle Mode: 13.4mph (6m/s) Manual Mode/Sport Mode: 44.7mph (20m/s) IPS Mode: 8.9mph (4m/s) Phone Mode: 11.2mph(5m/s)

Max Tilt Angle	Angle Mode: 30° Sport mode: 30° Phone Mode: 30°	Manual Mode: 20° IPS Mode: 10°
Max Angular Speed	Angle/Manual Mode: 120°/S Phone Mode: 120°/S	IPS Mode: 60°/S Sport mode: 200°/S
Max Service Ceiling Above Sea Level	16404ft (5000m)	
Operating Temperature Range	0°C-40°C	
Satellite Positioning Systems	GPS	
Hovering Accuracy Range	Vertical: ±0.3m (Angle/Sport/Phone Mode) ±0.1m (IPS Mode) Horizontal: ±0.5m (Angle/Sport/Phone Mode) ±0.2m (IPS Mode)	
Operating Environment	Regular Flight Condition, No Transparent Obstacles	
Sensor	Ultrasonic Sensor, IPS sensor	
CONTROLLER		
Product Name	Mantis Q Remote Controller	
Model	YUNMQRCP	
Video Transmission Distance/Range (Optimum condition)	up to 0.9 mile (1.5km)	
Buit-In Li-Po Battery	3.7V	
Max Charge Current	1.5A	
MOBILE DEVICE CONTROL		
Max Transmission Distance	262.5ft (80m)	
APP		
Required Operating System	iOS v9.0 or above (iOS 9.0 does not support voice control) Android V5.0 or above	
CAMERA		
Equivalent Focal Length	21.5mm	
FOV	117°	

Controllable Range (Pitch)	between -90°and +20°
Image Sensor	1/3.06 inch CMOS
Effective Pixels	13M Pixels
Video Stabilization	EIS 2-axis stabilized
SD Card Capacity	CLASS 10 U1/U3 16G
Operation Modes	Photo, Video
Auto/Manual	AE; Auto by default
ISO	100-3200 (100 by default)
Electronic Shutter	8s-1/8000s (1/60 by default) (for photo mode) 1/30s-1/8000s (1/30 by default) (for video mode)
Exposure Values	0, ±0.5, ±1.0, ±1.5, ±2.0, ±2.5, ±3.0 (0 by default)
Photo Size	4:3 (4160x3120), 16: 9 (4160x2340)
Photo Resolution	Medium, High, Ultrahigh (Ultrahigh by default)
Photo Format	JPEG, DNG
White Balance	Auto, Lock, Sunny, Cloudy, Fluorescent, Incandescent
Style	Nature, Saturation, Soft
Photography Mode	Normal, Gesture, Face Detection
Metering Mode	Spot Metering, Center Metering, Average Metering
Anti-flicker	Auto/50Hz/60Hz
Video Resolution	4K: 3840x2160 30fps, 1080P:1920x1080 30fps 720P: 1280x720 60fps
Video Format	MP4/MOV
OTA Upgrade	Support
Document Download	Support
Format SD Card	Support
Reset Camera Settings	Support
Downloading Speed of Photos	More than 2Mb/s
WiFi Activated Time	15s (FCC), 75s(CE)
Latency (depending on environmental conditions and mobile device)	Less than 200ms

OVERVIEW

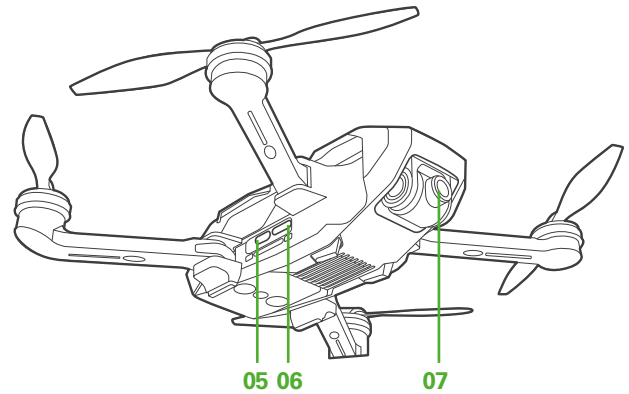
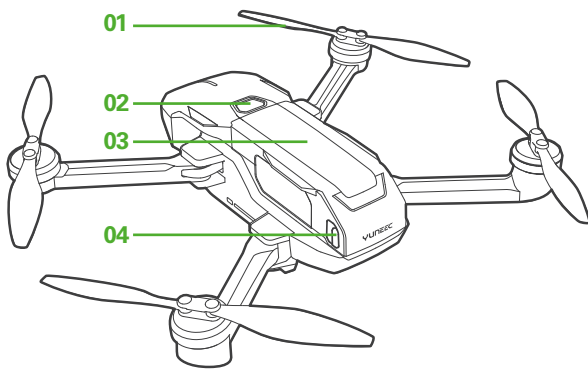

Aircraft

- 01 Propellers
- 02 Power Button
- 03 Battery
- 04 Battery Lock

- 05 USB Type-C
- 06 Micro SD Card Slot
- 07 Camera

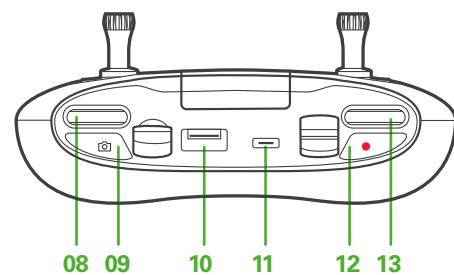
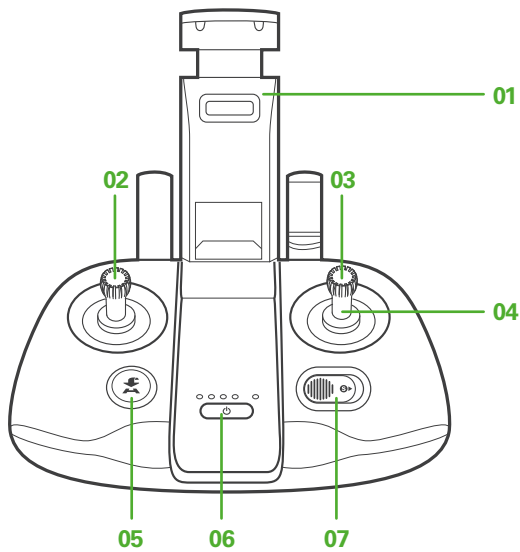

Remote Controller

- 01 Phone Holder
- 02 Short press the left joystick: Customizable Joystick
- 03 Short press the right joystick: Brake
- 04 Control Sticks
- 05 RTH Button
- 06 Power Button
- 07 Mode Switch

- 08 Camera Custom Settings Slider
- 09 Photo Button
- 10 Standard USB Port
- 11 USB Type-C
- 12 Video Recording Button
- 13 Camera Tilt Control Slider

CHARGING THE REMOTE CONTROLLER

Use USB Type-C to charge, approx. 2.5 hours.

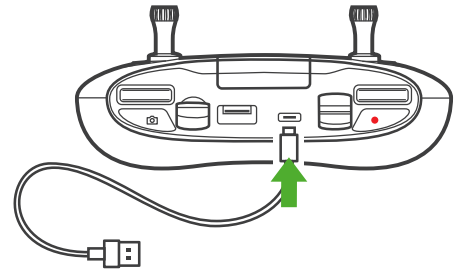

PREPARING THE AIRCRAFT

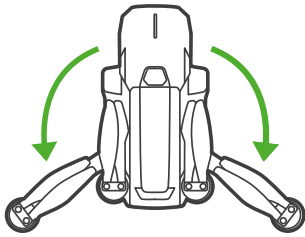

STEP 1: Unfold the Rear Arms

NOTICE: All arms and propellers must be unfolded before powering on.

NOTICE: To fold the Mantis G reverse the unfolding instructions.

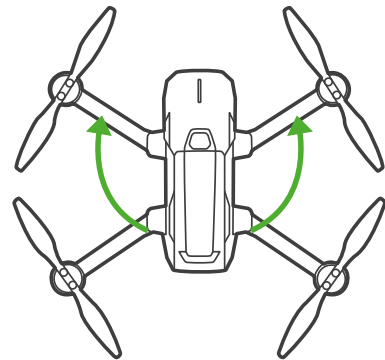

STEP 2: Unfold the Front Arms

CHARGING THE FLIGHT BATTERY

STEP 1: Press the battery locking button and remove the battery.

STEP 2: Plug the flight battery to the supplied charger as shown below.

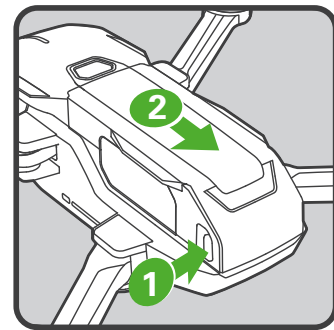

Solid Green: Power Standby

Green Flickering: Charging

Green Flashing: Error

Solid Green: Charge Completed

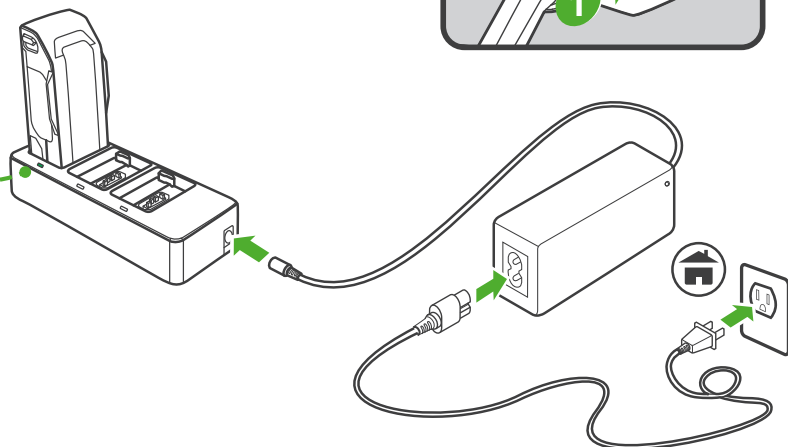

The LED indicator is solid green when the charger is powered on and ready to charge. The LED indicator flickers green while the battery is charging (charging time is approximately 1 hour), and turns solid green once charging is complete.

STEP 3: Push the flight battery into the aircraft until hearing a 'click'.

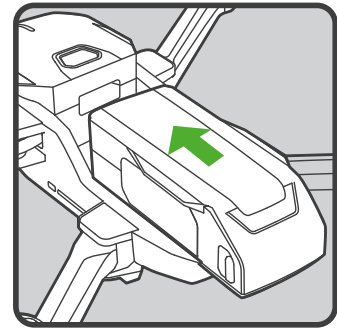

SD CARD INSTALLATION

NOTICE: Before using the Mantis G, a Micro SD card should be inserted into the camera.

NOTICE: Do not move the Micro SD card from the Mantis G when it is shooting.

STEP 1: Slide the memory card into the card slot according to the direction of the arrow.

STEP 2: When fully inserted, the card clicks into place. To remove the card, place your fingernail against the edge of the memory card and lightly press it further into the Micro SD card slot. The card springs out far enough to be removed.

CAUTION: Keep the memory card out of the reach of children to prevent swallowing.

WARNING: After inserting the Micro SD card in the computer, be sure to safely eject the SD card properly so it does not corrupt the card. If you directly pull out the Micro SD card from the computer and plug it into the aircraft, the aircraft with this Micro SD card won't support the digital video downlink, and the photo taking and video recording function can not be performed.

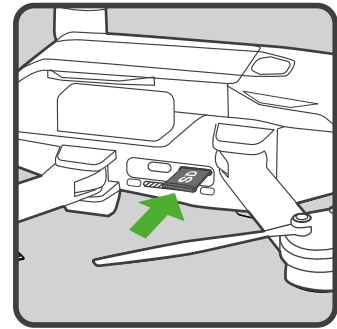

INSTALLING THE SMART DEVICE

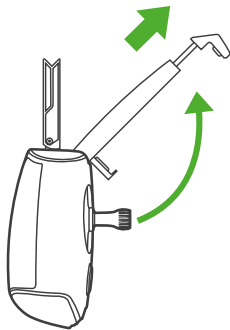

STEP 1:
Pull out the smart phone holder from the remote controller.

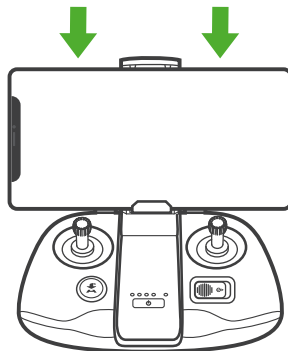

STEP 2:
Put your smart phone on the holder.

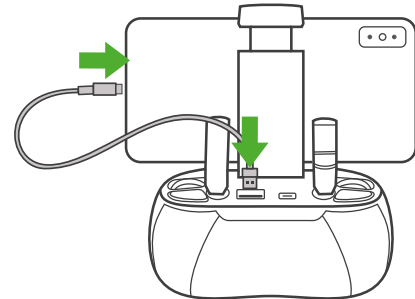

STEP 3:
Connect the smart phone with the remote controller through the iPhone or Android cable.

POWRING ON/OFF

Press the power button and hold for two seconds to power on/off the remote controller and the Mantis G in turn. When the main LED flashes blue slowly and emits a rising tone, the aircraft completes its initialization and boots up successfully.

Power on your smart phone, scan the QR code and download the Yuneec Pilot APP on your smart phone.

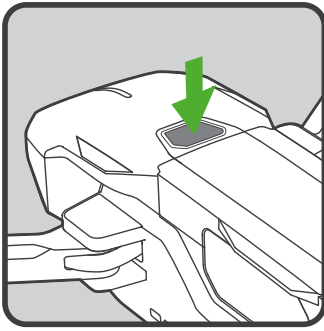

Power on the Mantis G

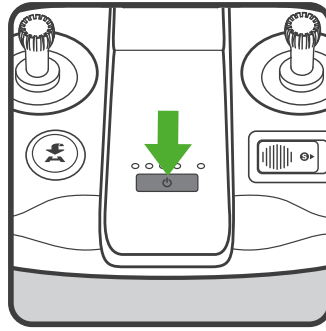

Power on the controller



Scan the QR code and download the App

NOTICE: If the all LED blinks white quickly and gives warning alarm, the initialization has failed. The aircraft needs to be powered on again. To power off the aircraft, press and hold the power button until the aircraft emits a falling tune.

BINDING PROCEDURES

1. Scan the QR Code

NOTICE: Please turn on the WiFi of your smart phone before scanning the QR code.

STEP 1: Launch Yuneec pilot app, and tap the icon [] whenever you see this icon in the App.



Method A

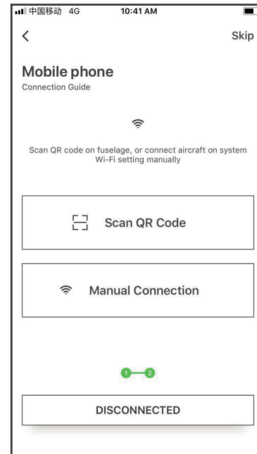

Method B

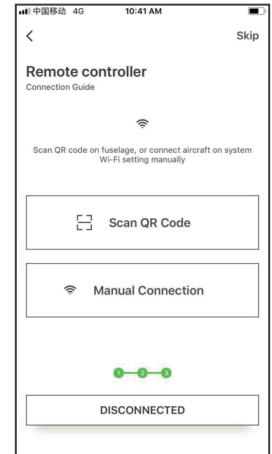

Method C

STEP 2: Scan the QR code at the front of the aircraft.

STEP 3: Wait for a few seconds till you hear the aircraft emit the acknowledge tone, which indicates the binding is successful.

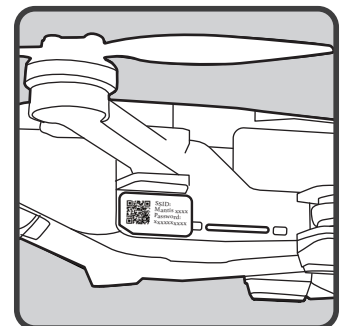

2. Manual Connection

Method A: Binding the Remote Control to the Aircraft

Launch Yuneec Pilot app, and follow on screen instructions to connect controller to the aircraft.

Step 1: Press the “DISCONNECTED” button.

Step 2: Select the “Remote Controller” option.

Step 3: Follow instructions on the app, and tap the “Next” button.

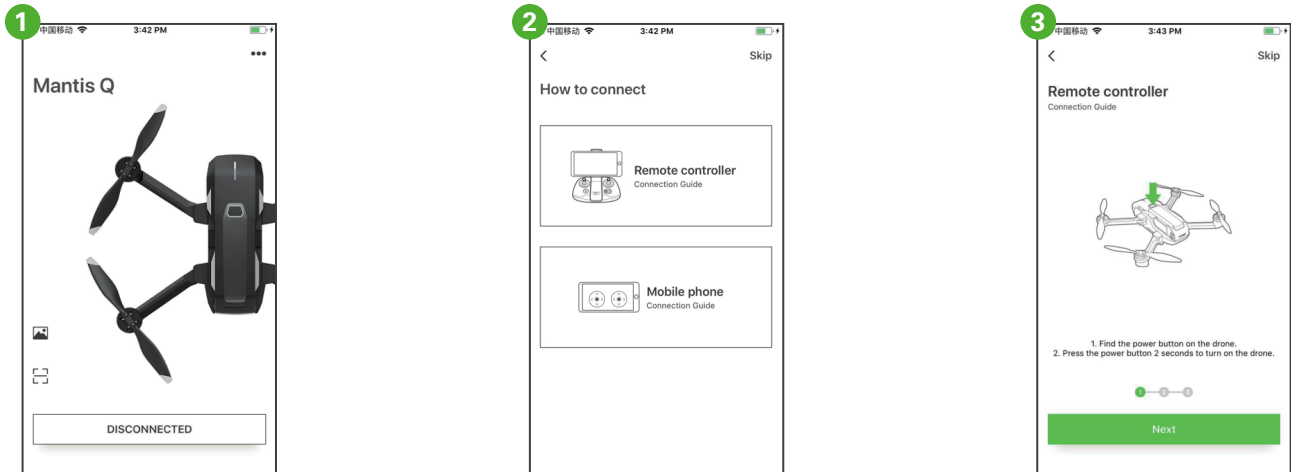

Step 4: Follow instructions on the app, and tap the “Next” button again.

Step 5: Tap “Manual Connection” option, and the system will jump to the next page.

Step 6: Then wait for the Wi-Fi of the aircraft appears on the screen (the Wi-Fi name starts with "Mantis"). Tap the corresponding Wi-Fi and input the password to complete the connection (The password can be found on the aircraft QR Code Sticker). Wait for a few seconds till you hear the aircraft emit the acknowledge tone, which indicates the binding is successful.

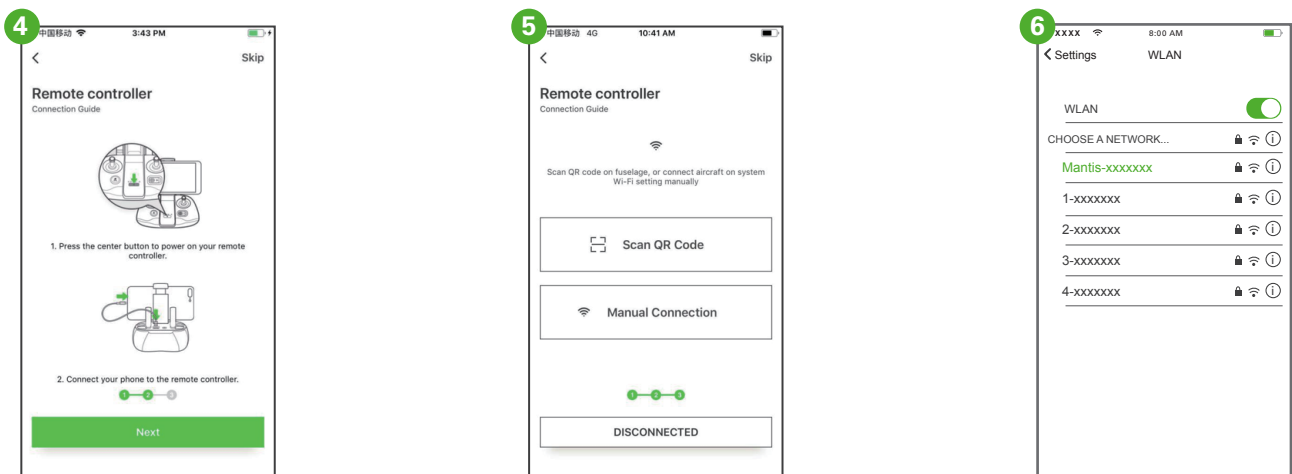

Method B: Binding the Smart Phone to the Aircraft

Launch Yuneec Pilot app, and follow on screen instructions to connect smart phone to the aircraft.

NOTICE: When the smart phone is connected to the aircraft by following the App instructions, the smart phone with iOS system should support version 11.0 and above.

- Step 1:** Press the “DISCONNECTED” button.
- Step 2:** Select the “Mobile phone” option.
- Step 3:** Follow instructions on the app, and tap the “Next” button.

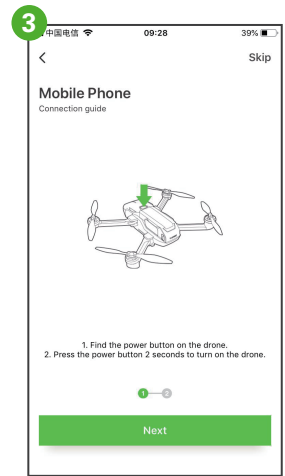
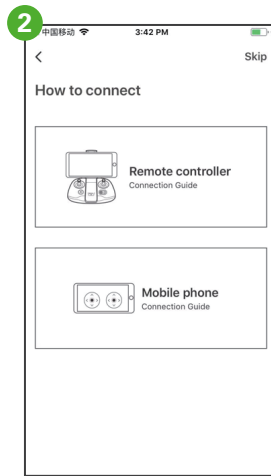

- Step 4:** Tap “Manual Connection” option, and the system will jump to the next page.
- Step 5:** Then wait for the Wi-Fi of the aircraft appears on the screen (the Wi-Fi name starts with "Mantis"). Tap the corresponding Wi-Fi and input the password to complete the connection (The password can be found on the aircraft QR Code Sticker). Wait for a few seconds till you hear the aircraft emit the acknowledge tone, which indicates the binding is successful.

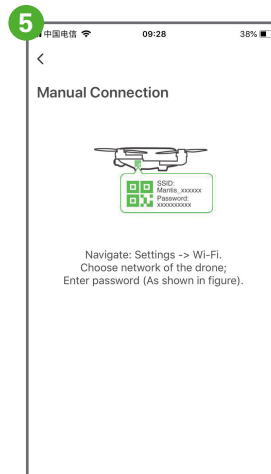
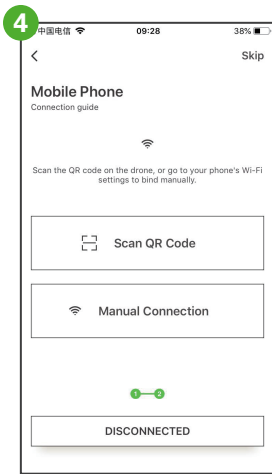

COMPASS CALIBRATION

It may be best to calibrate your compass in the following circumstances:

1. The aircraft is unused for more than 30 days.
2. The App interface displays that the compass is interfered and the LED lights of the rear arms flash yellow slowly.
3. The aircraft experienced a slight drift during your first flight.

Please go to the Settings section within your app and follow the on-screen instructions to calibrate the compass.

CAUTION: Do not calibrate the compass in parking garages, close to buildings or near roads with a metal core. For optimum performance, only calibrate Mantis G in open spaces, far away from power lines and other metal structures or concrete buildings.

NOTICE: Be sure to perform the compass calibration procedure at least 11 feet away from the nearest cell phone or other electronic devices to ensure proper calibration.

Step 1: Press the “START” button, and rotate the drone as the animations shown in the App.

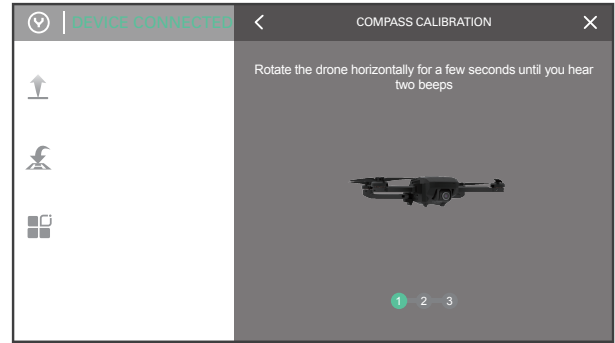
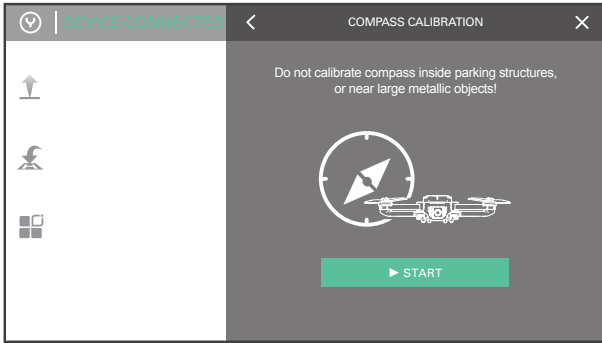

Step 2: Raise the drone and rotate the drone as the animations shown in the App.

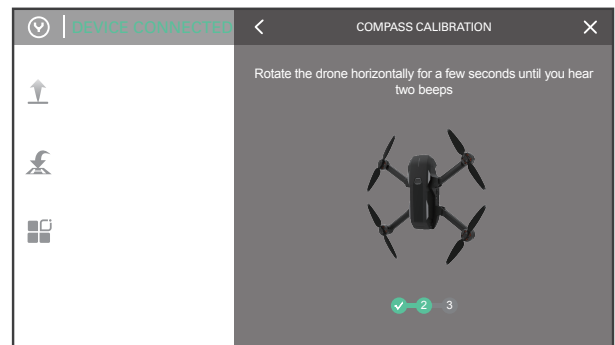
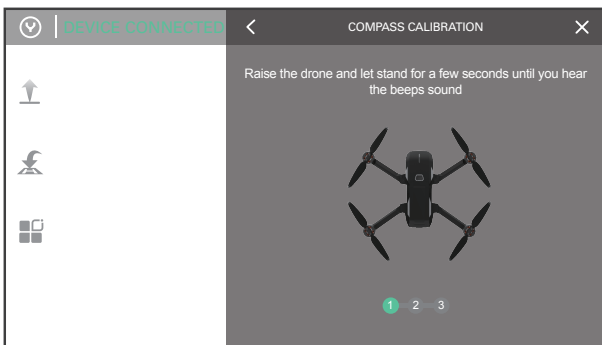

Step 3: Place the drone sideways and rotate the drone as the animations shown in the App.

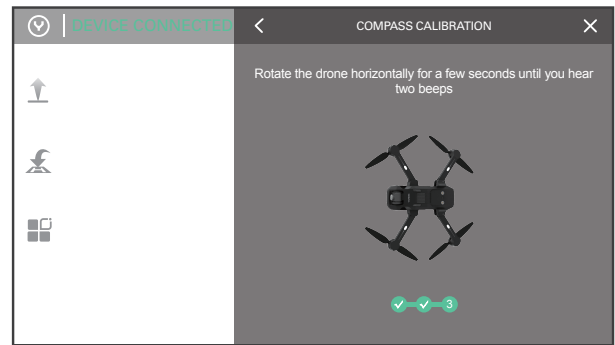
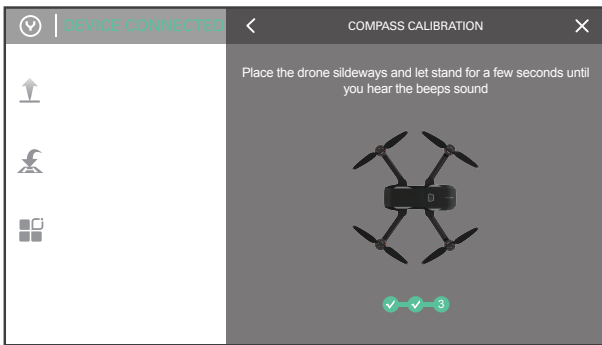

Step 4: After all these calibration procedures are performed, the interface will jump to the right page. It means that the compass calibration is completed.

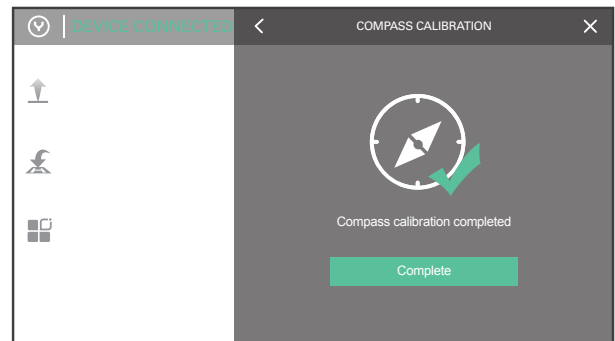

PLACEMENT BEFORE TAKEOFF

1. Outdoor Flying

WARNING: If you operate the Mantis G outside, please always place it in open areas (approximately 10000 square feet/930 square meters or more) that are free from people, vehicles, trees and other obstructions. Never fly near or above crowds, airports or buildings.

Never attempt to operate Mantis G nearby tall buildings/obstructions that do not offer a clear view of the sky (a minimum clearance of 100°).

Be sure to place the Mantis G on a level and stable surface before powering ON the Mantis G and the remote controller.

IMPORTANT NOTE: STEP BACK APPROXIMATELY 6.6 FEET (2 METERS) BEHIND THE MANTIS G.

2. Indoor Flying



If you operate the Mantis G in indoor environment, the IPS mode will be automatically activated when GPS can't be locked. The IPS is most suitable for indoor flight or without GPS locked.

NOTICE: When using IPS without GPS locked, make sure that the indoor illumination is sufficient. The IPS may not be able to position when the aircraft is flying over highly reflective surfaces or over highly repeated surface texture (such as the same color).

NOTICE: When flying indoor with IPS activated, the pilot should be cautious and not to fly too fast.

TAKE OFF

Press the power button and hold for two seconds to power on/off the remote controller and the Mantis G. Wait for the aircraft completing its initialization and booting up.

Option 1: Tap the icon [] on the APP, then slide the sliding block, and the aircraft will take off. Then the icon [] will turn Point-to-Land icon [].

Option 2: Move the sticks as shown and hold for about 2 seconds to start the motors. Slowly raise the left-hand stick to slightly above the center position. The aircraft will take off and climb slowly (or raise the stick further until it does). Allow the stick to return to the center position when the aircraft reaches the desired altitude.

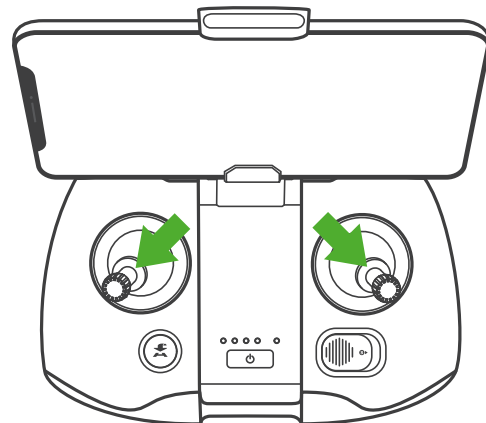
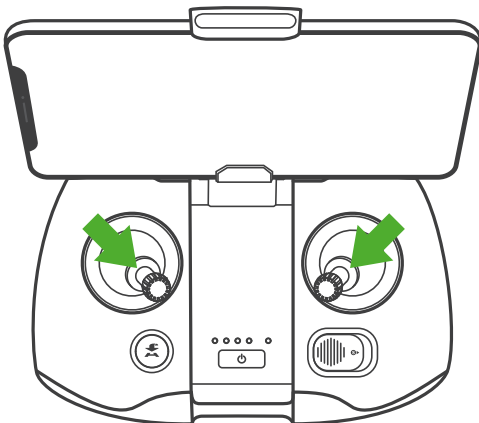

DIRECTION CONTROL

Move the control sticks as below to control the direction of the Mantis G. The default flight control is known as Mode 2.

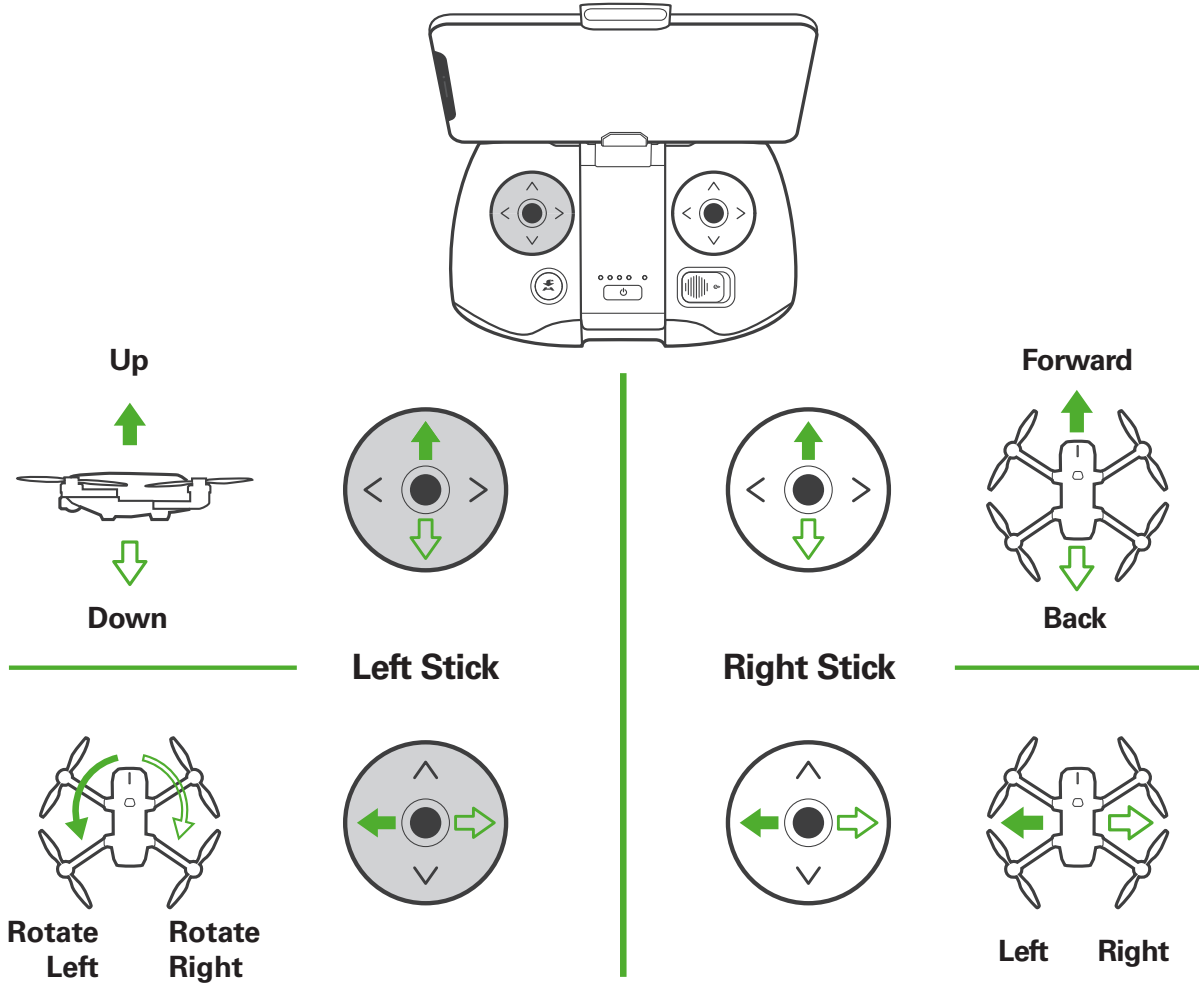

OPTIMAL TRANSMISSION RANGE

The signal between the aircraft and the remote controller is most reliable when the antennas are positioned in relation to the aircraft as below.

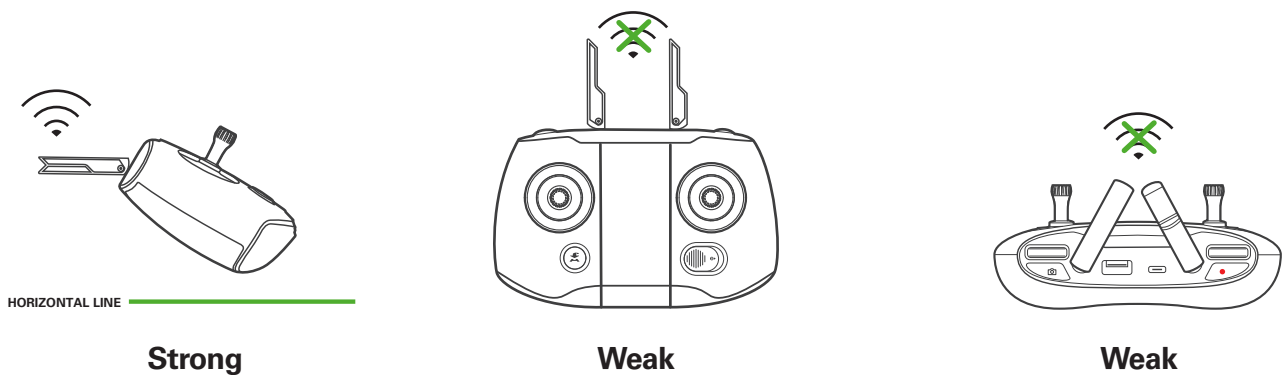

Ensure that the aircraft is flying within the optimal transmission range. To maintain optimal transmission performance, adjust the antennas of the remote controller to be parallel to the ground.

TAKING PHOTOS AND RECORDING VIDEOS

The remote controller seamlessly integrates control of the camera, so you can easily pan left and right, take still photos and start/stop video recording using the corresponding buttons located on top.

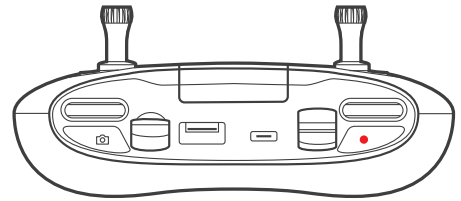



To Take A Still Photo

Press the Photo Button [] on the right side of the remote controller, or tap the photo taking icon in the App to take a photo. You'll hear an audible 'shutter' sound from the smart phone.

To Start / Stop Recording Video

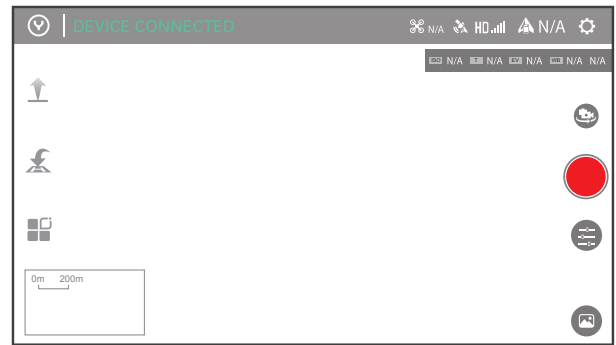
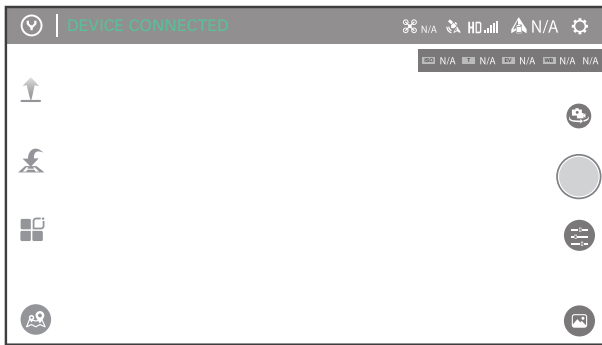
Press the Video Recording Button [] on the left side of the remote controller, or tap the video recording icon in the App to start/stop recording video. You'll hear an audible indication from the smart phone each time the recording starts/stops.



NOTICE: Tap the [] icon, you can switch between photo taking and video recording mode in the App.



Camera Tilt Control

There is a camera tilt control slider on the top left side of the remote controller. When the slider slides to the left side position, the camera will tilt down. When the slider is in the right side position, the camera will tilt up.

VOICE CONTROL

Mantis G users have a few options available when it comes to controlling the aircraft without fiddling with its buttons or touchscreen.



Voice control on the new Mantis G isn't enabled out of the box. To turn the feature on, you should proceed the following procedures:

Step 1: Tap the Setting icon [] and select the remote controller icon [].

Step 2: Scroll down the drop-down menu, press the "Auxiliary Control" option, and slide the "Voice Control" switch from left to right.

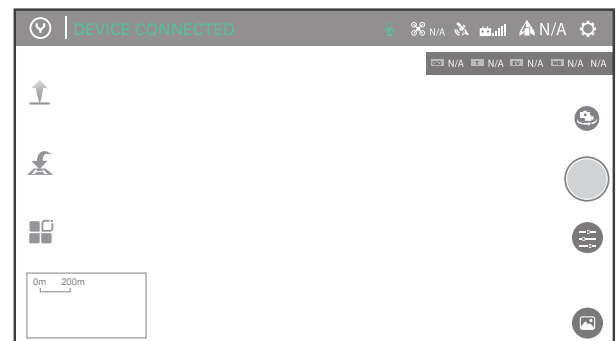
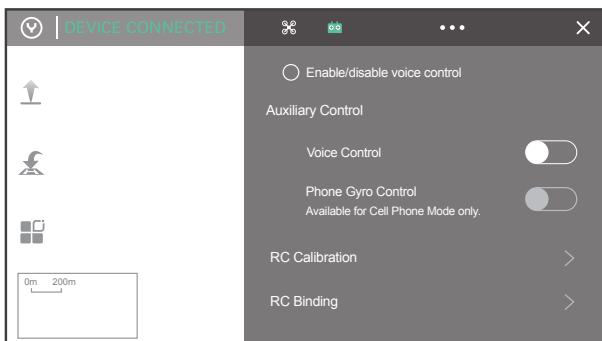
Step 3: With the voice control function is enabled, the microphone icon [] will appear on the top menu bar.



Step 4: You can say commands to activate the voice control function. When your voice command is detected by the system, the microphone icon will turn from [] to [], and the aircraft can perform your commands.

NOTICE: If your voice command is not detected by the system in one minute, the voice control function will go into standby mode. You need to wake it up again.



Here' s a complete list of commands you can give:

Keyword to wakeup	Wake up
Commands for camera	Take picture; take a picture; take photo; take a photo; take selfie; recording; start recording; record a video; video; stop, stop recording
Commands for fly	Takeoff; Landing; Go home
To stop RTH or stop landing	Stop (reuse with stop for stopping recording)
Commands for confirmation	OK; confirm; yes
Commands to cancel	cancel; no; reject; nope

Other commands will be supported in a future update.

INSTANT SOCIAL SHARING

The instant social sharing function allows you to share photos with your contacts and friends, via your mobile applications. Uploading photos and videos onto social media services and websites can be a great way to share memorable moments with friends and family, or to boost engagement with your community.

To enable this function, you just need to perform the following procedures:

STEP 1: Select a picture from the Drone Gallery.

STEP 2: Tap the download icon [] on the lower right corner of the screen.

NOTICE: The photos should be downloaded first before sharing to social media.

STEP 3: Tap [] icon and the photos can be shared to Facebook, Twitter, Wechat and other supported applications.

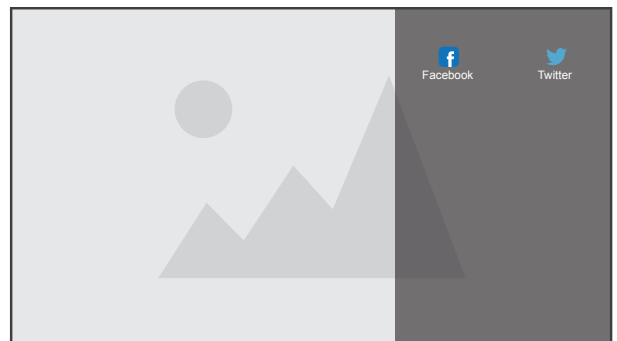
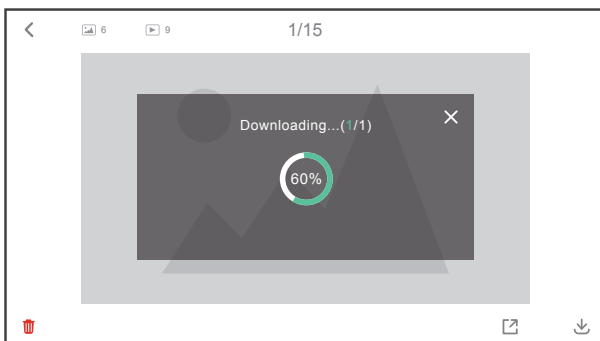

FLIGHT MODES

Angle Mode

When the Mode Switch is in the left position, the aircraft is in Angle Mode. Angle mode works best when the GPS signal is strong. The aircraft utilizes GPS to locate itself, stabilize, and navigate between obstacles. The advanced functions such as Visual Tracking, POI, other supported applications, are enabled in this mode. The maximum flight attitude angle is 30 ° and the maximum flight speed is 13.4mph (21.6km/h).

NOTICE: Angle mode requires larger stick movements to achieve high speeds.

Sport Mode

When the Mode Switch is in the right position, the aircraft is in Sport Mode. The maximum flight speed of the aircraft is increased to 45 mph (72km/h).

NOTICE: In sport mode, the aircraft responses are optimized for agility and speed making it more responsive to stick movements. The aircraft's responsiveness is significantly increased in Sport mode. A slight stick movement on the remote controller will produce a large travel distance of the aircraft. Be cautious and maintain adequate maneuvering space during flight.

NOTICE: The aircraft's maximum speed and braking distance are significantly increased in Sport mode.

NOTICE: The Mantis G has other three flight modes that the users can select:

1. The IPS Mode is activated in the absence of GPS signal. The advanced functions are unavailable when this mode is used. The maximum speed of the aircraft under this mode is 8.9mph (14.4km/h).
2. When the GPS signal cannot be detected and the optical flow cannot be found, the Manual Mode will be activated. If the joysticks of the remote controller are released, the aircraft will drift in horizon direction. The advanced functions are unavailable when this mode is used. The maximum speed of the aircraft under this mode is 45mph (72km/h).
3. When the remote controller is not connected to the aircraft, but the smart device is connected to the aircraft, the aircraft will be in Phone Mode, controlled by the smart device.

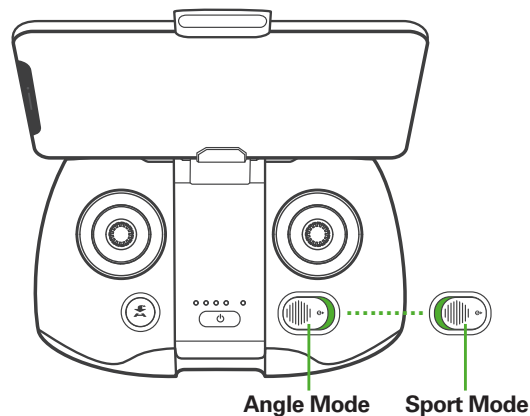

ADVANCED FUNCTIONS

The Mantis G supports Advanced Functions including Journey, POI, Visual Tracking.

NOTICE: When the remaining power of the aircraft is lower than 25%, the Mantis G will exit Advanced Functions and the functions can't be activated.

Journey

Journey function enables Mantis G to capture the perfect aerial selfie or any scenic shot much easier and faster. Depending on the pilot's desired setting, Mantis G will fly backward in the opposite direction of the aircraft lens and return.

NOTICE: Before activating this function, you should fly the aircraft to the starting position, which must be at least 6.5ft (2m) above ground level. Tap [] on the left column of the screen to enter the journey function. Distance can be adjusted manually between 33ft (10m) and 295 (90m), and speed between 2.2mph (1m/s) and 11.2 (5m/s).

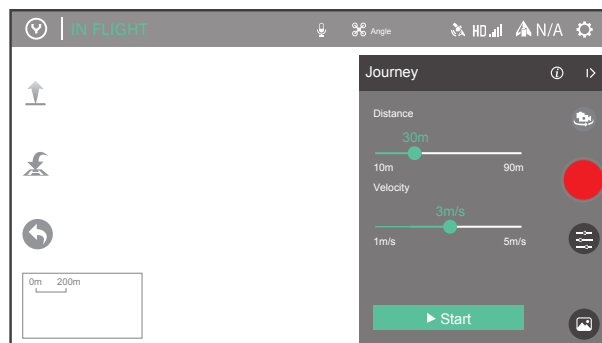
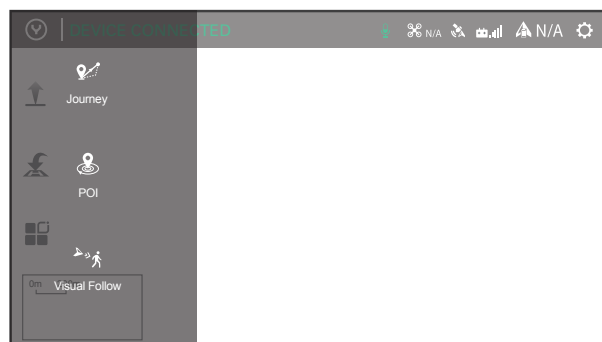

POI

POI function allows the pilot to select a subject they would like to orbit and have Mantis G orbit that subject autonomously. Tap [] on the left column of the screen and choose the POI function. Fly the aircraft to a desired point of interest, move the slider bar on the right side of the screen to set the distance and velocity under the POI function. Tap the "Start" icon, then that desired point will be marked as the center point for orbit. Push the joysticks on the remote controller, the aircraft will begin to execute POI, and the "Start" button will turn to be "Pause". The pilot can pause the task by tapping this button.

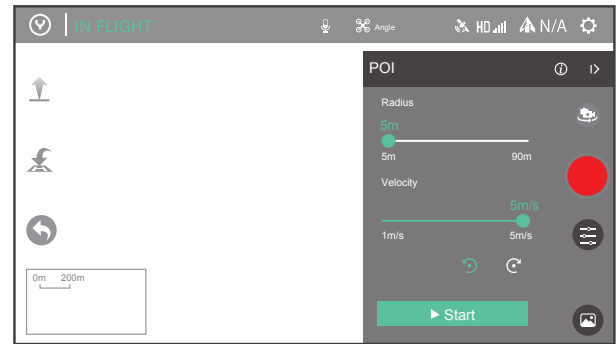

Visual Tracking

The Visual Tracking function allows Mantis G to follow the target subject. Tap [] on the left column of the screen, to choose the Visual Tracking function.

1. Follow Me

Select your target subject in Camera View (tap the subject and drag a box around the subject), the aircraft will turn its nose to the target subject and keep the target within its view, then track and follow the target subject's movements autonomously.

2. Watch Me

In Watch Me Mode, select your target subject in Camera View (tap the subject and drag a box around the subject), the drone will hover in a place and spin or adjust the camera to the target subject to record the subject.

NOTICE: In Watch Me mode, the aircraft can only adjust its nose to the target subject and hover in a place, but can not track and follow the target subject's movements.

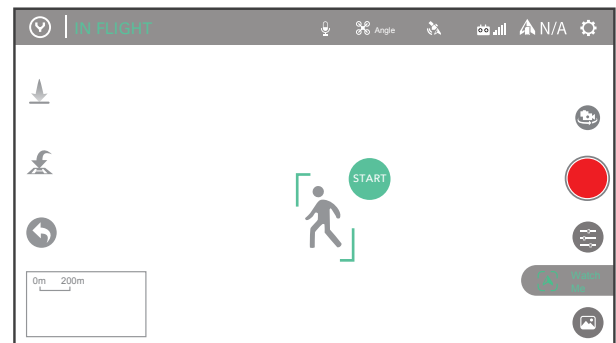
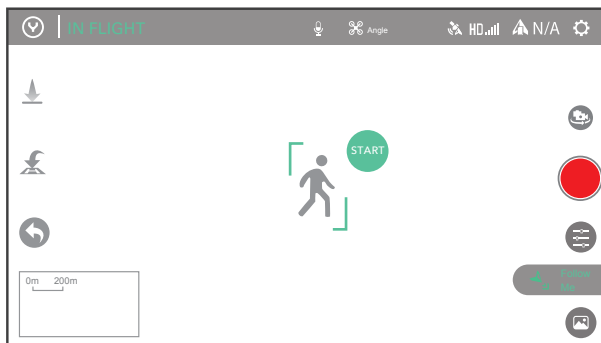

RETURN TO HOME

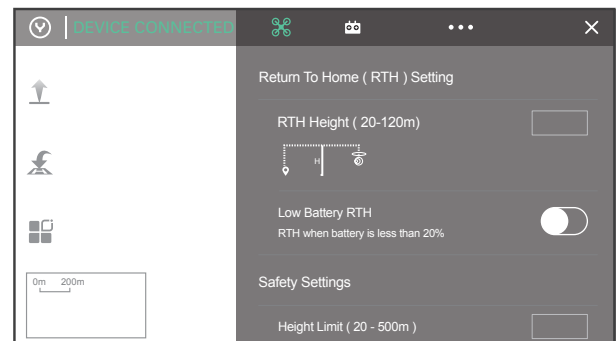

The Return to Home (RTH) function brings the aircraft back to the last recorded Home Point. There are 3 types of RTH:



Smart RTH

If the GPS signal is sufficiently strong, Smart RTH can be used to bring the aircraft back to the Home Point. Smart RTH is initiated either by tapping [] icon in the App or by pressing and holding the RTH button on the remote controller.

Low Battery RTH

Tap the Setting icon [] on the top right corner of the screen, and then touch the aircraft icon []. Under the “Return to Home (RTH) Settings” option, you can slide the “Low Battery RTH” switch from left to right to activate the Low Battery RTH function.

The RTH function will be triggered when the flight battery is depleted to a point that may affect the safe return of the aircraft.

Failsafe RTH

1. When you are operating the aircraft under GPS mode in the outdoor environment, Failsafe RTH will be automatically activated if the remote control signal is lost for a specified amount of time (3 seconds when using the remote controller and 20 seconds when flying with a smart device). If the signal is re-established after the Failsafe RTH is activated, the aircraft will still perform the Failsafe RTH.

NOTICE: When the RTH mode is activated, the flight path is as follows:

1. If the aircraft is less than 26ft (8m) from the Home Point, it will climb to an altitude vertically first (the altitude is determined by the distance between the aircraft and the Home Point), then fly back at the current height and descend vertically until it lands automatically.
2. If the aircraft is further than 26ft (8m) from the Home Point, and the flight height of the aircraft is lower than the desired altitude, it will climb to the desired altitude vertically first, then fly back at the current height and descend vertically until it lands automatically.
3. If the aircraft is further than 26ft (8m) from the Home Point, and the flight height of the aircraft is higher than the desired altitude, it will fly back at the current height, and then descend vertically until it lands automatically.

Smart RTH and Low Battery RTH can be interrupted in the following four circumstances:

1. Tap [] icon in the App to interrupt the RTH.
2. Short press the RTH button on the remote controller.
3. Slide the Mode Switch on the remote controller to interrupt the RTH.
4. Short press the right joystick on the remote controller.

LANDING

Auto Land:

Press the Point to Land Icon [], then slide the sliding block, and the aircraft will land automatically.

WARNING: Always land as soon as possible after the first low level voltage battery warning, or land immediately after the second level low voltage battery warning by the Motor LED Status Indicators flashing rapidly.

WARNING: When the aircraft battery power is less than 5%, the aircraft will be forced to land immediately and can't be interrupted.

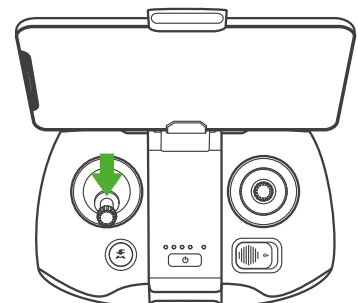

Manual Land:

Position the Mantis G above the area where you would like to land. Slowly lower the left-hand stick to below the center position. Mantis G will descend slowly and land.



LED Status Indication

The color of the icon indicates the color of the LED.

-  indicates the LED flashing rapidly.
-  indicates the LED flashing slowly.
-  indicates the LED solid on.

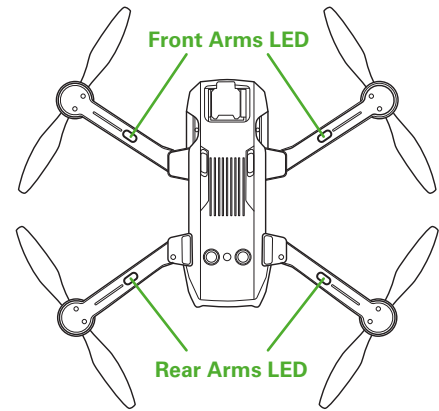
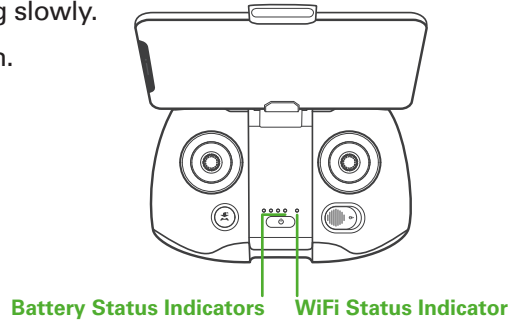



STATUS	Front Arms LED	Rear Arms LED
Start-Up		
Power On		
Binding Fails		
Binding Succeed / During Flight		
In Angle Mode		
In Sport Mode		
In IPS Mode		
In Manual Mode		
In WiFi Mode		
Low Voltage Battery Warning		
First Level Low Voltage Warning		
Second Level Low Voltage Warning		
Controller LED Status Indications	Battery Status Indicators	WiFi Status Indicators
Power on		
Connected to WiFi		

FIRMWARE UPDATE

NOTICE: When you connect the aircraft or remote controller to the app, you will be notified if a new firmware update is available. To start updating, connect your smart device to the Internet and follow on-screen instructions. Note that you cannot update the firmware if the remote controller is not linked to the aircraft.

Follow the instructions below to update the firmware:

STEP 1: Tap the setting icon [] and select [].

STEP 2: Touch “Software Updates” option to proceed.

STEP 3: Press the “Download” button.

STEP 4: Wait for the firmware to be downloaded. The firmware update will start automatically.

STEP 5: Reboot the aircraft after the firmware update is complete.

NOTICE: The firmware update will take around 15 minutes. Please wait patiently until the update is complete.

NOTICE: Do not disconnect the aircraft from the computer during an update.

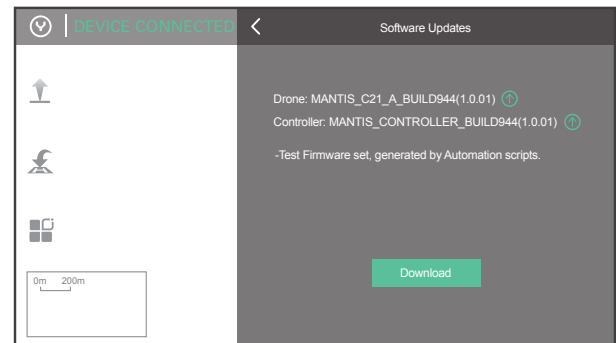
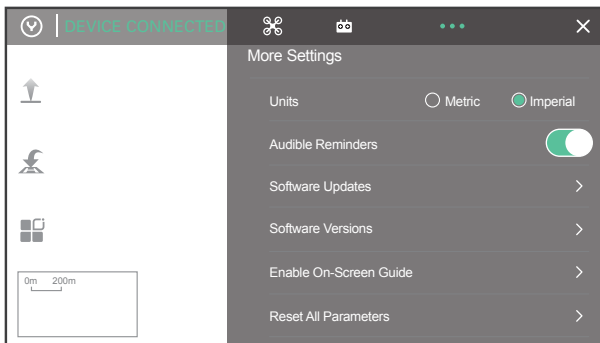

DISCLAIMER

昆山优尼电能运动科技有限公司 (Yuneec International (China) Co., Ltd.) shall not be held liable for any damage, injury or for use of the product in violation with legal regulations, especially in the following circumstances:

Damage and/or injury as well violation of legal regulations resulting from a failure to comply with the operating instructions or the instructions at www.yuneec.com, product information, user manual and other legally binding information;

Damage and/or injury as well violation of legal regulations brought about by the influence of alcohol, drugs, medication or other narcotics which may impact on the concentration of the user;

The same applies to illnesses effecting the concentration of the user (dizziness, tiredness, nausea etc.) or other factors compromising mental and physical capabilities.

Intentionally caused damage, injury or violation of legal regulations;

Any request for compensation caused by an accident resulting from use of the product;

Malfunction of the product caused by retrofitting or replacement with components which did not come from Yuneec;

Damage and/or injury caused by the use of replica parts (non-original parts);

Damage and/or injury as well as violation of legal regulations caused by incorrect operation or misjudgment;

Damage and/or injury caused by damaged spare parts or not using original Yuneec spare parts;

Damage and/or injury caused by unauthorized change settings and/or parameters;

Damage and/or injury caused by modify and/or add parts;

Damage and/or injury as well as violation of legal regulations caused by ignoring the low voltage battery warning;

Damage and/or injury caused by knowingly and negligibly flying with a damaged model or one which is unfit to fly, e.g. due to dirt, water penetration, coarse particles, oil or a model which has not been correctly or completely assembled or if the main components exhibit visible damage, defects or missing parts;

Damage and/or injury as well as violation of legal regulations caused by use of the product in a no-fly zone, e.g. next to an airfield, above a motorway or a natural conservation area;

Damage and/or injury as well as violation of legal regulations caused by operating the model in a magnetic field

(e.g. high voltage lines, electricity/ transformer stations, radio towers, mobile phone masts etc.), a strong wireless signal environment, no-fly zones, poor visibility and in the event of vision impairments or other impacts on the pilot which are left unchecked etc;

Damage and/or injury brought about through a violation of the legal regulations for operating the model, in unsuitable weather conditions, e.g. rain, wind, snow, hail, storms, hurricanes etc;

Damage and/or injury as well as violation of legal regulations caused by force majeure, e.g. collision, fire, explosion, flooding, tsunami, landslide, avalanche, earthquake or other forces of nature;

Damage and/or injury as well as violation of legal regulations caused by the illegal or immoral use of the model, e.g. capturing videos or recording data which infringes upon/harms the privacy of other people;

Damage and/or injury as well as violation of legal regulations caused by incorrect use of the batteries, protection systems, chargers or aircraft;

Consequential damage caused by the incorrect operation of any kind of system components and accessory parts,

especially memory cards, whereby image or video material from the camera can become defect;

Any non-compliance with legal obligations, personal injury, material damage and environmental damage caused by use and a failure to comply with the local laws and regulations;

Damage and/or injury as well as violation of legal regulations caused by hazardous use without sufficient practical experience;

Damage and/or injury as well as violation of legal regulations caused by flying in legally defined no-fly zones; and/or.

Further losses which do not fall within the scope of use defined by Yuneec as improper.

This product is designed for both professional use and personal private use. Any domestic and/or international laws, code and regulations in force as the time of taking off must be adhered to.

COLLECTION AND PROCESSING OF DATA

Yuneec may collect navigation information such as GPS data to help improve our products.

We may also collect Depth Map information and Infrared Image information from your drone delivered to our service center for repair and maintenance service or any other service.

We may also collect other information such as device information, server log information, etc. We may also collect personal information used in registration if you choose to become a registered user and any other information user provided to Yuneec. We may also collect information which user send to other users, and the recipients and senders of such information.

We reserve the right to disclose your information if required to do so by law or in the good-faith belief that such disclosure is needed to comply with applicable laws, for example in response to a court order, judicial subpoena, warrant or request from government, or otherwise cooperating with government agencies or law enforcement.

We also reserve the right to disclose your information that we believe in good faith is necessary or appropriate to: (i) protect ourselves or others from fraudulent, unlawful, or abusive activities; (ii) take precautions against potential liability; (iii) protect the security of the Yuneec Apps embedded into or downloaded onto your drone or any associated equipment and services; (iv) protect the legal rights of ourselves or any others.

Any information we collected maybe disclosed or transferred to an acquirer, successor or assignee as part of any potential merger, acquisition, debt financing or other activities that involves transfer of business assets.

We may make the aggregated non-personal information of the users available to third parties for various purposes, including (i) complying with various report obligations; (ii) marketing efforts; (iii) analyzing product safety; (iv) understanding and analyzing our users' interests, habits, usage pattern for certain functionalities, services, content, etc.

BATTERY WARNINGS AND USAGE GUIDELINES

WARNING: Lithium Polymer (LiPo) batteries are significantly more volatile than alkaline, NiCd or NiMH batteries. All instructions and warnings must be followed exactly to prevent property damage and/or serious injury as the mishandling of LiPo batteries can result in fire. By handling, charging or using the included LiPo battery

you assume all risks associated with LiPo batteries. If you do not agree with these conditions please return the complete product in new, unused condition to the place of purchase immediately.

You must always charge the LiPo battery in a safe, well-ventilated area away from flammable materials.

Never charge the LiPo battery unattended at any time. When charging the battery you must always remain in constant observation to monitor the charging process and react immediately to any potential problems that may occur.

After flying/discharging the LiPo battery you must allow it to cool to ambient/room temperature before recharging.

To charge the LiPo battery you must use only the included charger or a suitably compatible LiPo battery charger. Failure to do so may result in a fire causing property damage and/or serious injury.

If at any time the LiPo battery begins to balloon or swell, discontinue charging or discharging immediately. Quickly and safely disconnect the battery, then place it in a safe, open area away from flammable materials to observe it for at least 15 minutes. Continuing to charge or discharge a battery that has begun to balloon or swell can result in a fire. A battery that has ballooned or swollen even a small amount must be removed from service completely. Do not over-discharge the LiPo battery. Discharging the battery too low can cause damage to the battery resulting in reduced power, flight duration or failure of the battery entirely. LiPo cells should not be discharged to below 3.0V each under load.

Store the LiPo battery at room temperature and in a dry area for best results.

When charging, transporting or temporarily storing the LiPo battery the temperature range should be from approximately 40–120° F (5–49° C). Do not store the battery or aircraft in a hot garage, car or direct sunlight. If stored in a hot garage or car the battery can be damaged or even catch fire.

Never leave batteries, chargers and power supplies unattended during use.

Never attempt to charge low voltage, ballooned/swollen, damaged or wet batteries.

Never allow children under 14 years of age to charge batteries.

Never charge a battery if any of the wire leads have been damaged or shorted.

Never attempt to disassemble the battery, charger or power supply.

Never drop batteries, chargers or power supplies.

Always inspect the battery, charger and power supply before charging.

Always ensure correct polarity before connecting batteries, chargers and power supplies.

Always disconnect the battery after charging.

Always terminate all processes if the battery, charger or power supply malfunctions.

GENERAL SAFETY PRECAUTIONS AND WARNINGS

WARNING: Failure to use this product in the intended manner as described in the quick start guide and instruction manual can result in damage to the product, property and/or cause serious injury. A Radio Controlled (RC) multirotor aircraft, APV platform, drone, etc. is not a toy! If misused it can cause serious bodily harm and damage to property.

WARNING: As the user of this product you are solely and wholly responsible for operating it in a manner that does not endanger yourself and others or result in damage to the product or the property of others.

Keep your hands, face and other parts of your body away from the spinning propellers/rotor blades and other moving parts at all times. Keep items that could impact or become entangled away from the propellers/rotor blades including debris, parts, tools, loose clothing, etc.

Always operate your aircraft in open areas that are free from people, vehicles and other obstructions.

Never fly near or above crowds, airports or buildings.

To ensure proper operation and safe flight performance never attempt to operate your aircraft nearby buildings or other obstructions that do not offer a clear view of the sky and can restrict GPS reception.

Do not attempt to operate your aircraft in areas with potential magnetic and/or radio interference including areas nearby broadcast towers, power transmission stations, high voltage power lines, etc.

Always keep a safe distance in all directions around your aircraft to avoid collisions and/or injury. This aircraft is controlled by a radio signal subject to interference from many sources outside your control. Interference can cause momentary loss of control.

To ensure proper and safe operation of the automatic landing function in Return Home Mode you must start the motors with the aircraft in an open space and achieve a proper GPS lock.

Do not attempt to operate your aircraft with any worn and/or damaged components, parts, etc. including, but not

limited to, damaged propellers/rotor blades, old batteries, etc.

Never operate your aircraft in poor or severe weather conditions including heavy winds, precipitation, lightning, etc.

Always begin to operate your aircraft with a fully charged battery. Always land as soon as possible after the first level low voltage battery warning or land immediately after the second level low voltage battery warning.

Always operate your aircraft when the voltage of the battery in the transmitter/personal ground station is in a safe range (as indicated by the LED status indicator light of the transmitter/personal ground station).

Always keep the aircraft in clear line of sight and under control, and keep the transmitter/personal ground station powered on while the aircraft is powered on.

Always move the throttle control stick down fully and turn off the power in the event the propellers/rotor blades come into contact with any objects.

Always allow components and parts to cool after use before touching them and flying again.

Always remove batteries after use and store/transport them per the corresponding guidelines.

Avoid water exposure to all electronic components, parts, etc. not specifically designed and protected for use in water. Moisture causes damage to electronic components and parts.

Never place any portion of the aircraft or any related accessories, components or parts in your mouth as doing so could cause serious injury or even death.

Always keep chemicals, small parts and electronic components out of the reach of children.

To ensure safe fly, it is recommended to install the propeller protectors when operating the aircraft indoors or nearby crowds.

Carefully follow the instructions and warnings included with this aircraft and any related accessories, components or parts (including, but not limited to, chargers, rechargeable batteries, etc.).

CAMERA USAGE WARNINGS

NOTICE

For the latest product information, please check our official website: www.yuneec.com.

WARNING

Do not expose the lens of the camera to extreme light sources.

Do not operate the camera in the rain or in environments with high humidity.

Do not try to repair the camera. Repairs must go to an authorized service center.

WARNING

Read the entire instruction manual to become familiar with the features of the product before operating.

Do not use with incompatible components or alter this product in any way outside of the instructions provided by Yuneec.

Failure to use this product in the intended manner as described in instruction manual can result in damage to the product, property and/or cause serious injury.

For Mantis G

FCC Statement

This equipment has been tested and found to comply with the limits for Part 15 of the FCC rules.

These limits are designed to provide reasonable protection against harmful interference in a residential installation. This equipment generates, uses and can radiate radio frequency energy and, if not installed and used in accordance with the instructions, may cause harmful interference to radio communications.

However, there is no guarantee that interference will not occur in a particular installation.

If this equipment does cause harmful interference to radio or television reception, which can be determined by turning the equipment off and on, the user is encouraged to try to correct the interference by one or more of the following measures:

- Reorient or relocate the receiving antenna.
- Increase the separation between the equipment and receiver.
- Connect the equipment to an outlet on a circuit different from that to which the receiver is connected.
- Consult the dealer or an experienced radio/TV technician for help.

This device complies with part 15 of the FCC rules. Operation is subject to the following two conditions:

This device may not cause harmful interference, and (2) this device must accept any interference received, including interference that may cause undesired operation.

Any Changes or modifications not expressly approved by the party responsible for compliance could void the user's authority to operate the equipment

RF Exposure Warning

This equipment complies with FCC radiation exposure limits set forth for an uncontrolled environment .This equipment must be installed and operated in accordance with provided instructions and the antenna(s) used for this transmitter must be installed to provide a separation distance of at least 20 cm from all persons and must not be co-located or operating in conjunction with any other antenna or transmitter. End-users and install-ers must be provided with antenna installation instructions and transmitter operating conditions for satisfying RF exposure compliance.

IC Radiation Exposure Statement for Canada

This device complies with Industry Canada license-exempt RSS standard (s).Operation is subject to the following two conditions: (1) this device may not cause interference, and (2) this device must accept any interference, including interference that may cause undesired operation of the device.Le présent appareil est conforme aux CNR d'Industrie Canada applicables aux appareils radio exempts de licence. L'exploitation est autorisée aux deux conditions suivantes : (1) l'appareil ne doit pas produire de brouillage, et (2) l'utilisateur de l'appareil doit accepter tout brouillage radioélectrique subi, même si le brouillage est susceptible d'en compromettre le fonctionnement. This equipment complies with IC RSS-102 radiation exposure limit set forth for an uncontrolled environment. Cet équipement respecte les limites d'exposition aux rayonnements IC définies pour un environnement non contrôlé.

ISED RF exposure statement:

This equipment complies with ISED radiation exposure limits set forth for an uncontrolled environment. This equipment should be installed and operated with minimum distance 20cm between the radiator & your body. This transmitter must not be co-located or operating in conjunction with any other antenna or transmitter. Le rayonnement de la classe b respecte ISED fixaient un environnement non contrôlés. Installation et mise en œuvre de ce matériel devrait avec échangeur distance minimale entre 20 cm ton corps. Lanceurs ou ne peuvent pas coexister cette antenne ou capteurs avec d' autres.

CE Warning Statement

This device meets the EU requirements on the limitation of the general public to electromagnetic fields by way of health protection.

EU Operation Frequency (The Maximum Transmitted Power)

Mantis Q Remote Controller:

5G: 5470-5725MHz (27dBm)

Mantis G:

5G: 5470-5725 MHz(27dBm)

EU Compliance Statement

Hereby, Yuneec International (China) Co., Ltd. declares that this device is in compliance with the essential requirements and other relevant provisions of the RED Directive 2014/53/EU. The full text of the EU Declaration of Conformity is available at the following internet address: <http://yuneec/de-downloads>

Please visit the address above and enter corresponding product page.

For Mantis Q Remote Controller

FCC warnings:

FCC Statement:

Any Changes or modifications not expressly approved by the party responsible for compliance could void the user's authority to operate the equipment.

This device complies with part 15 of the FCC Rules. Operation is subject to the following two conditions:

- (1) This device may not cause harmful interference.
- (2) This device must accept any interference received, including interference that may cause undesired operation.

RF Exposure Information:

This equipment complies with FCC SAR limits set forth for an uncontrolled environment .This equipment must be installed and operated in accordance with provided instructions and the antenna(s) used for this transmitter must be installed to provide a separation distance of at least 10mm from all persons and must not be co-located or operating in conjunction with any other antenna or transmitter. End-users and install-ers must be provided with antenna installation instructions and transmitter operating conditions for satisfying RF exposure compliance.

ISED RSS Warning/ISED RF Exposure Statement:

ISED RSS Warning:

This device complies with Innovation, Science and Economic Development Canada licence-exempt RSS standard(s). Operation is subject to the following two conditions: (1) this device may not cause interference, and (2) this device must accept any interference, including interference that may cause undesired operation of the device.

Le présent appareil est conforme aux CNR d'ISED applicables aux appareils radio exempts de licence.

L'exploitation est autorisée aux deux conditions suivantes:

- (1) l'appareil ne doit pas produire de brouillage, et
- (2) l'utilisateur de l'appareil doit accepter tout brouillage radioélectrique subi, même si le brouillage est susceptible d'en compromettre le fonctionnement.

ISED RF exposure statement:

This equipment complies with ISED SAR limits set forth for an uncontrolled environment. This equipment should be installed and operated with minimum distance 10mm between the radiator & your body. This transmitter must not be co-located or operating in conjunction with any other antenna or transmitter.

Cet équipement est conforme aux limites ISED SAR définies pour un environnement non contrôlé. Cet équipement doit être installé et utilisé avec une distance minimale de 10 mm entre le radiateur et votre corps. Cet émetteur ne doit pas être placé au même emplacement ni être utilisé avec toute autre antenne ou émetteur.

Customer Service

Manufacturer:

昆山优尼电能运动科技有限公司 (Yunee International (China) Co., Ltd.)
Address: No.388 East Zhengwei Road, JinxiTown, Kunshan, Jiangsu 215324, China

Distributor:

CN: Shanghai Yunee Digi-Tech Co., Limited
Address: 6F, CaoHeJing Kehui Tower, No.1188, Qinzhou North Road, XuHui District, China
Tel.: +86 400 8207 506
saleschina@yunee.com

HK: Yunee HK
Address: Unit 2301, 23/F, 9 Chong Yip Street, Kwun Tong, Kowloon, Hong Kong, China
Tel.: 0512-50121243
hkcs@yunee.com

US: Yunee USA Inc
Address: 2275 Sampson Ave, Suite 200 Corona, CA 92879, USA
Tel.: +1 844 898 6332
uscs@yuneeusa.com

EU: Yunee Europe GmbH
Address: Nikolaus-Otto-Strasse 4, 24568 Kaltenkirchen, Germany
Tel.: +49 4191 932620
eucs@yunee.com

UK: YUNEEC UK
Address: 181 Victoria Road, Barnet, Hertfordshire EN4 9PA, UK
Tel.: +44(0) 208 449 4321
info@yunee.uk

YUNEEC