

## MEASUREMENT REPORT

### FCC PART 15.407 / RSS-247 WLAN 802.11a/n

---

**FCC ID:** 2ACS5-YUNMQRC  
**IC:** 11554B-YUNMQRC  
**APPLICANT:** Yuneec Technology Co., Limited

**Application Type:** Certification  
**Product:** Mantis Q Remote Controller  
**Model No.:** YUNMQRC  
**Brand Name:** YUNEEC  
**FCC Classification:** Unlicensed National Information Infrastructure (NII)  
**FCC Rule Part(s):** Part 15.407  
**IC Rule(s):** RSS-247 Issue 2, RSS-GEN Issue 4  
**Test Procedure(s):** ANSI C63.10-2013, KDB 789033 D02v02r01  
**Test Date:** April 13 ~ 25, 2018

Reviewed By : Paddy Chen  
( Paddy Chen )  
Approved By : Chenz Ker  
( Chenz Ker )



The test results relate only to the samples tested.

This equipment has been shown to be capable of compliance with the applicable technical standards as indicated in the measurement report and was tested in accordance with the measurement procedures specified in KDB 789033 D02v02r01. Test results reported herein relate only to the item(s) tested.

The test report shall not be reproduced except in full without the written approval of MRT Technology (Taiwan) Co., Ltd.

---

### Revision History

Report No.	Version	Description	Issue Date	Note
1804TW0108-U1	Rev. 01	Initial Report	02-07-2018	Valid

---

# CONTENTS

Description	Page
<b>§2.1033 General Information</b> .....	<b>5</b>
<b>1. INTRODUCTION</b> .....	<b>6</b>
1.1. Scope .....	6
1.2. MRT Test Location .....	6
<b>2. PRODUCT INFORMATION</b> .....	<b>7</b>
2.1. Equipment Description .....	7
2.2. Product Specification Subjective to this Report.....	7
2.3. Working Frequencies for this report .....	7
2.4. Description of Available Antennas .....	7
2.5. Description of Antenna RF Port.....	8
2.6. Test Mode .....	8
2.7. Description of Test Software .....	9
2.8. Device Capabilities.....	10
2.9. Test Configuration .....	10
2.10. EMI Suppression Device(s)/Modifications.....	10
2.11. Labeling Requirements .....	11
<b>3. DESCRIPTION OF TEST</b> .....	<b>12</b>
3.1. Evaluation Procedure .....	12
3.2. AC Line Conducted Emissions.....	12
3.3. Radiated Emissions.....	13
<b>4. ANTENNA REQUIREMENTS</b> .....	<b>14</b>
<b>5. TEST EQUIPMENT CALIBRATION DATE</b> .....	<b>15</b>
<b>6. MEASUREMENT UNCERTAINTY</b> .....	<b>16</b>
<b>7. TEST RESULT</b> .....	<b>17</b>
7.1. Summary .....	17
7.2. 26dB Bandwidth Measurement .....	19
7.2.1. Test Limit .....	19
7.2.2. Test Procedure used .....	19
7.2.3. Test Setting.....	19
7.2.4. Test Setup .....	19
7.2.5. Test Result.....	20
7.3. 6dB Bandwidth Measurement .....	23
7.3.1. Test Limit .....	23

---

7.3.2. Test Procedure used .....	23
7.3.3. Test Setting.....	23
7.3.4. Test Setup .....	23
7.3.5. Test Result.....	24
7.4. Output Power Measurement .....	27
7.4.1. Test Limit .....	27
7.4.2. Test Procedure Used.....	27
7.4.3. Test Setting.....	27
7.4.4. Test Setup .....	28
7.4.5. Test Result.....	28
7.5. Power Spectral Density Measurement .....	30
7.5.1. Test Limit .....	30
7.5.2. Test Procedure Used.....	30
7.5.3. Test Setting.....	30
7.5.4. Test Setup .....	31
7.5.5. Test Result.....	32
7.6. Frequency Stability Measurement .....	35
7.6.1. Test Limit .....	35
7.6.2. Test Procedure Used.....	35
7.6.3. Test Setup .....	36
7.6.4. Test Result.....	37
7.7. Radiated Spurious Emission Measurement .....	38
7.7.1. Test Limit .....	38
7.7.2. Test Procedure Used.....	38
7.7.3. Test Setting.....	39
7.7.4. Test Setup .....	40
7.7.5. Test Result.....	42
7.8. Radiated Restricted Band Edge Measurement .....	56
7.8.1. Test Limit .....	56
7.8.2. Test Result.....	60
7.9. AC Conducted Emissions Measurement.....	76
7.9.1. Test Limit .....	76
7.9.2. Test Setup .....	76
7.9.3. Test Result.....	77
<b>8. CONCLUSION.....</b>	<b>79</b>

## §2.1033 General Information

<b>Applicant:</b>	Yunee Technology Co., Limited
<b>Applicant Address:</b>	Unit 2301, 23/F, 9 Chong Yip Street, Kwun Tong, Kowloon, Hong Kong.
<b>Manufacturer:</b>	Yunee International (China) Co., Ltd.
<b>Manufacturer Address:</b>	No.388 East Zhengwei Road, Jinxi Town, Kunshan, Jiangsu 215324, China
<b>Test Site:</b>	MRT Technology (Taiwan) Co., Ltd
<b>Test Site Address:</b>	No. 38, Fuxing Second Rd., Guishan Dist., Taoyuan City 333, Taiwan (R.O.C)
<b>FCC Registration No.:</b>	153292
<b>IC Registration No.:</b>	21723
<b>Test Device Serial No.:</b>	N/A <input type="checkbox"/> Production <input checked="" type="checkbox"/> Pre-Production <input type="checkbox"/> Engineering

### Test Facility / Accreditations

Measurements were performed at MRT Laboratory located in Fuxing Rd., Taoyuan, Taiwan (R.O.C)

- MRT facility is a FCC registered (Reg. No. 153292) test facility with the site description report on file and is designated by the FCC as an Accredited Test Film.
- MRT facility is an IC registered (MRT Reg. No. 21723-1) test laboratory with the site description on file at Industry Canada.
- MRT Lab is accredited to ISO 17025 by the American Association for Laboratory Accreditation (TAF) under the American Association for Laboratory Accreditation Program (TAF Cert. No. 3261) in EMC, Telecommunications and Radio testing for FCC, Industry Taiwan, EU and TELEC Rules.

## 1. INTRODUCTION

### 1.1. Scope

Measurement and determination of electromagnetic emissions (EMC) of radio frequency devices including intentional and/or unintentional radiators for compliance with the technical rules and regulations of the Federal Communications Commission and the Industry Canada Certification and Engineering Bureau.

### 1.2. MRT Test Location

The map below shows the location of the MRT LABORATORY, its proximity to the Taoyuan City. These measurement tests were conducted at the MRT Technology (Taiwan) Co., Ltd. Facility located at No.38, Fuxing 2nd Rd., Guishan Dist., Taoyuan City 33377, Taiwan (R.O.C).

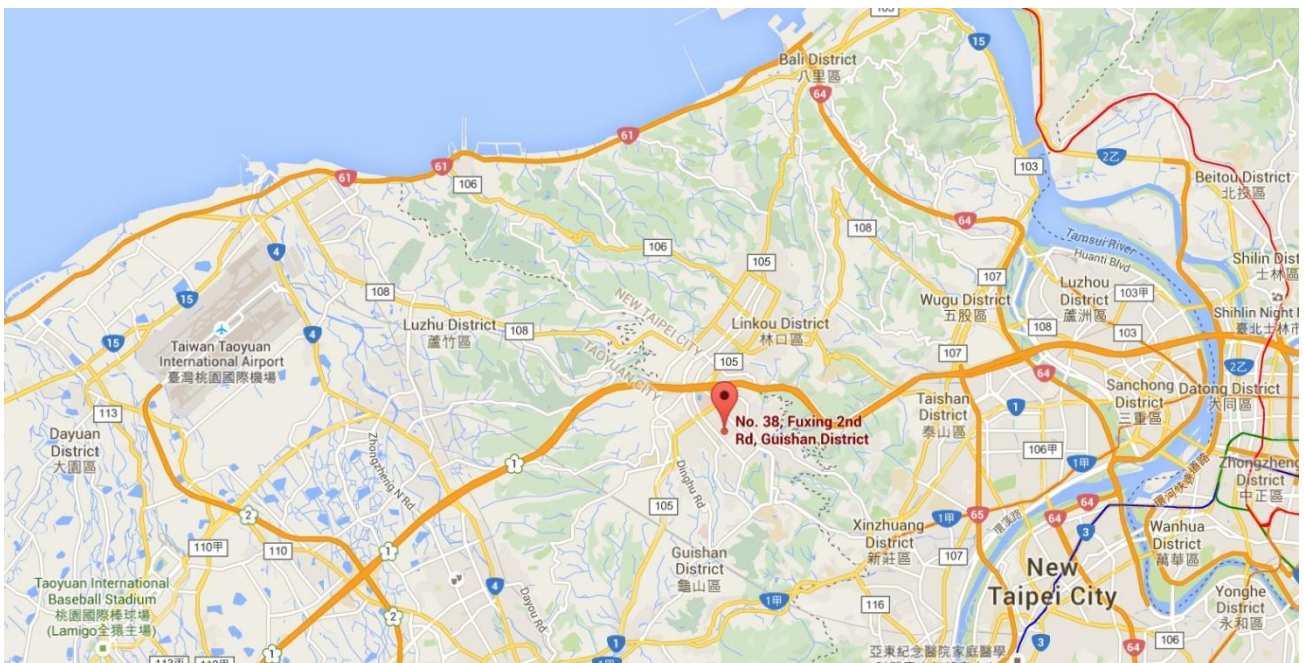

## 2. PRODUCT INFORMATION

### 2.1. Equipment Description

Product Name:	Mantis Q Remote Controller
Model No.:	YUNMQRC
Wi-Fi Specification:	802.11a/n-HT20
Battery Specification:	3.7V, 3000mAh

### 2.2. Product Specification Subjective to this Report

Frequency Range:	802.11a/n-HT20: 5180~5240MHz, 5745~5825MHz
Type of Modulation:	802.11a/n-HT20: OFDM
Data Rate:	802.11a: 6/9/12/18/24/36/48/54Mbps 802.11n-HT20: up to 72.2Mbps

### 2.3. Working Frequencies for this report

802.11a/n-HT20

Channel	Frequency	Channel	Frequency	Channel	Frequency
36	5180 MHz	40	5200 MHz	44	5220 MHz
48	5240 MHz	149	5745 MHz	153	5765 MHz
157	5785 MHz	161	5805 MHz	165	5825 MHz

Note: For the 5150 ~ 5250MHz band, the device can't use it when market on Canada.

### 2.4. Description of Available Antennas

Antenna Type	Manufacturer	Frequency Band (MHz)	Max Peak Gain (dBi)
Omni-directional Antenna	Yuneeec International (China) Co., Ltd.	5150 ~ 5250	2.98
		5725 ~ 5850	3.57

## 2.5. Description of Antenna RF Port

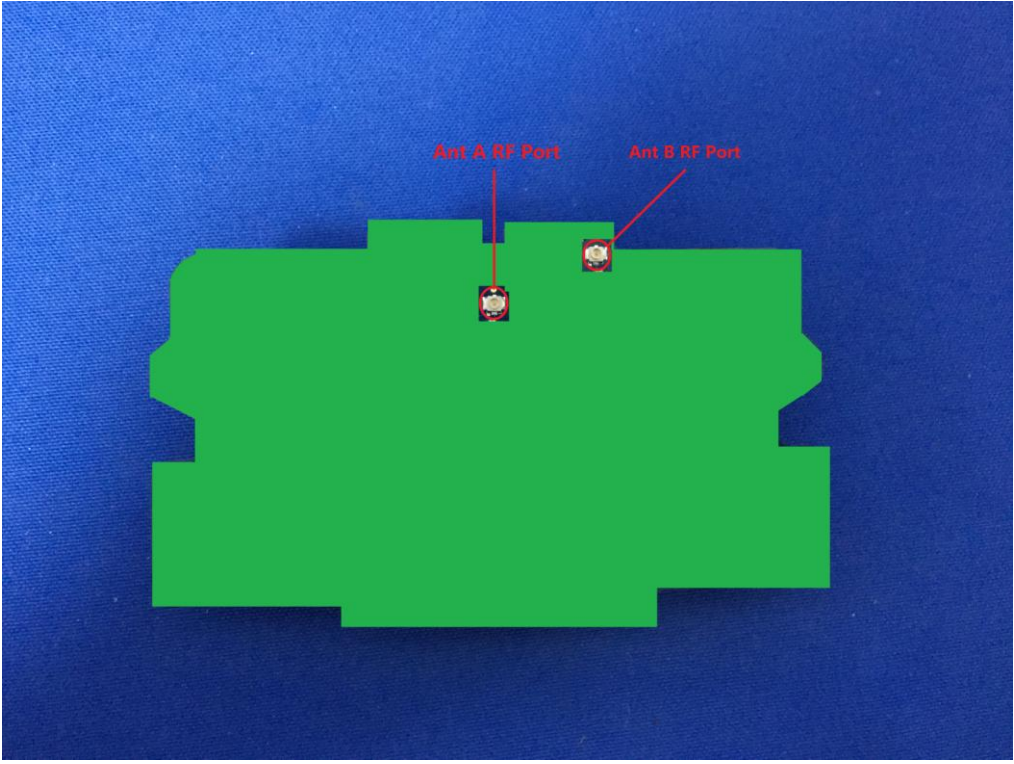
Antenna RF Port		
--	5GHz RF Port	
Software Control Port	Ant A	Ant B
		

Note: The 5GHz Wi-Fi Module has two RF ports (RF Port A and RF Port B), only the RF Port A can transmit, the RF Port B can't transmit, both RF Port A and RF Port B can receive as declared by the manufacturer.

## 2.6. Test Mode

Test Mode	Mode 1: Transmit by 802.11a (6Mbps)
	Mode 2: Transmit by 802.11n-HT20 (MCS0)



## 2.7. Description of Test Software

The test utility software used during testing was engineering directive ordered by applicant.

Power Parameter Value for Ant A

Mode	Channel No.	Frequency (MHz)	Power Parameter Value
802.11a	36	5180	47.0
	44	5220	45.0
	48	5240	44.0
	149	5745	46.0
	157	5785	48.0
	165	5825	49.0
802.11n-HT20	36	5180	48.0
	44	5220	45.0
	48	5240	44.0
	149	5745	47.0
	157	5785	50.0
	165	5825	50.0

### 2.8. Device Capabilities

This device contains the following capabilities:

5GHz WLAN (NII)

**Note:** 5GHz (UNII) operation is possible in 20MHz channel bandwidths. The maximum achievable duty cycles for all modes were determined based on measurements performed on a spectrum analyzer in zero-span mode with RBW = 8MHz, VBW = 50MHz.

The duty cycles are as follows:

Test Mode	Duty Cycle
802.11a	94.70 %
802.11n-HT20	94.54 %

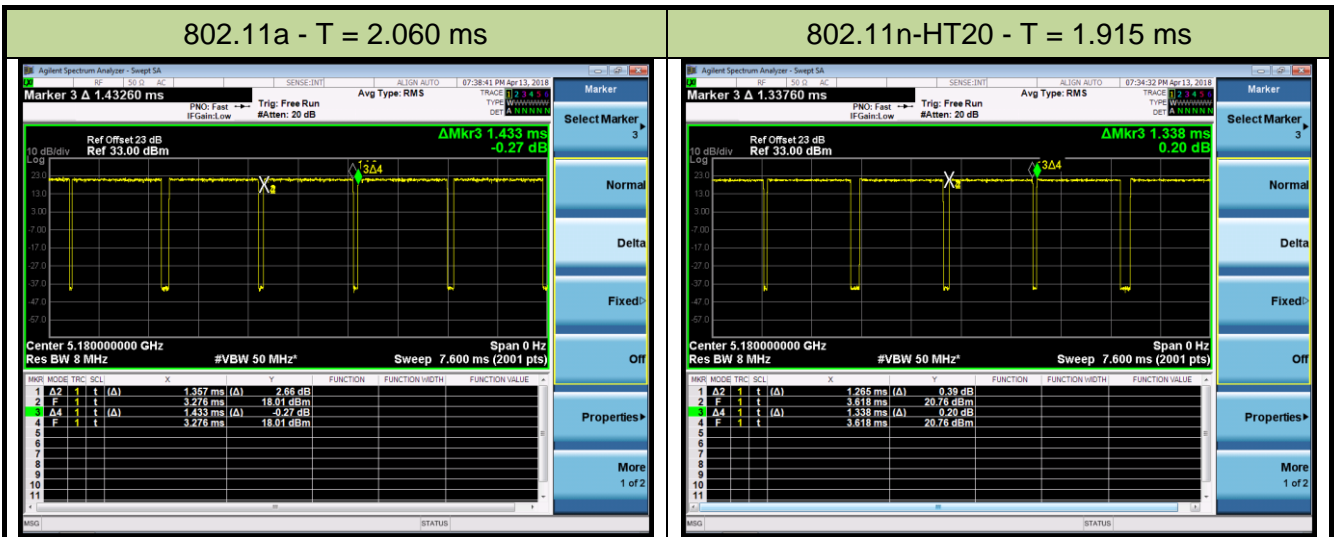

### 2.9. Test Configuration

The device was tested per the guidance of KDB 789033 D02v02r01. ANSI C63.10-2013 was used to reference the appropriate EUT setup for radiated spurious emissions testing and AC line conducted testing.

### 2.10. EMI Suppression Device(s)/Modifications

No EMI suppression device(s) were added and/or no modifications were made during testing.

## **2.11. Labeling Requirements**

### Per 2.1074 & 15.19; Docket 95-19

The label shall be permanently affixed at a conspicuous location on the device; instruction manual or pamphlet supplied to the user and be readily visible to the purchaser at the time of purchase.

However, when the device is so small wherein placement of the label with specified statement is not practical, only the FCC ID must be displayed on the device per Section 15.19(a)(5). Please see attachment for FCC ID label and label location.

### RSP-100 Issue 11 Section 3

The manufacturer, importer or distributor shall meet the labelling requirements set out in this section for every unit:

- (i) prior to marketing in Canada, for products manufactured in Canada
- (ii) prior to importation into Canada, for imported products

For information regarding the e-labelling option, see Notice 2014–DRS1003. The label for the certified product represents the manufacturer's or importer's compliance with Innovation, Science and Economic Development Canada's (ISED) regulatory requirements.

Please see attachment for IC label and label location.

### 3. DESCRIPTION OF TEST

#### 3.1. Evaluation Procedure

The measurement procedures described in the American National Standard for Testing Unlicensed Wireless Devices (ANSI C63.10-2013), and the guidance provided in KDB 789033 D02v02r01 were used in the measurement.

**Deviation from measurement procedure.....None**

#### 3.2. AC Line Conducted Emissions

The line-conducted facility is located inside an 8'x4'x4' shielded enclosure. A 1m x 2m wooden table 80cm high is placed 40cm away from the vertical wall and 80cm away from the sidewall of the shielded room. Two 10kHz-30MHz, 50Ω/50uH Line-Impedance Stabilization Networks (LISNs) are bonded to the shielded room floor. Power to the LISNs is filtered by external high-current high-insertion loss power line filters. These filters attenuate ambient signal noise from entering the measurement lines. These filters are also bonded to the shielded enclosure.

The EUT is powered from one LISN and the support equipment is powered from the second LISN. All interconnecting cables more than 1 meter were shortened to a 1 meter length by non-inductive bundling (serpentine fashion) and draped over the back edge of the test table. All cables were at least 40cm above the horizontal reference ground-plane. Power cables for support equipment were routed down to the second LISN while ensuring that that cables were not draped over the second LISN. Sufficient time for the EUT, support equipment, and test equipment was allowed in order for them to warm up to their normal operating condition. The RF output of the LISN was connected to the receiver and exploratory measurements were made to determine the frequencies producing the maximum emission from the EUT. The receiver was scanned from 150kHz to 30MHz. The detector function was set to peak mode for exploratory measurements while the bandwidth of the analyzer was set to 9kHz. The EUT, support equipment, and interconnecting cables were arranged and manipulated to maximize each emission. Each emission was also maximized by varying: power lines, the mode of operation or data exchange speed, or support equipment whichever determined the worst-case emission. Once the worst case emissions have been identified, the one EUT cable configuration/arrangement and mode of operation that produced these emissions are used for final measurements on the same test site. The analyzer is set to CISPR quasi-peak and average detectors with a 9kHz resolution bandwidth for final measurements.

An extension cord was used to connect to a single LISN which powered by EUT. The extension cord was calibrated with LISN, the impedance and insertion loss are compliance with the requirements as stated in ANSI C63.10-2013.

### 3.3. Radiated Emissions

The radiated test facilities consisted of an indoor 3 meter semi-anechoic chamber used for final measurements and exploratory measurements, when necessary. The measurement area is contained within the semi-anechoic chamber which is shielded from any ambient interference. For measurements above 1GHz absorbers are arranged on the floor between the turn table and the antenna mast in such a way so as to maximize the reduction of reflections. For measurements below 1GHz, the absorbers are removed. A MF Model 210SS turntable is used for radiated measurement. It is a continuously rotatable, remote controlled, metallic turntable and 2 meters (6.56 ft.) in diameter. The turn table is flush with the raised floor of the chamber in order to maintain its function as a ground plane. An 80cm high PVC support structure is placed on top of the turntable.

For all measurements, the spectrum was scanned through all EUT azimuths and from 1 to 4 meter receive antenna height using a broadband antenna from 30MHz up to the upper frequency shown in 15.33(b)(1) depending on the highest frequency generated or used in the device or on which the device operates or tunes. For frequencies above 1GHz, linearly polarized double ridge horn antennas were used. For frequencies below 30MHz, a calibrated loop antenna was used. When exploratory measurements were necessary, they were performed at 1 meter test distance inside the semi-anechoic chamber using broadband antennas, broadband amplifiers, and spectrum analyzers to determine the frequencies and modes producing the maximum emissions. Sufficient time for the EUT, support equipment, and test equipment was allowed in order for them to warm up to their normal operating condition. The test set-up for frequencies below 1GHz was placed on top of the 0.8 meter high, 1 x 1.5 meter table; and test set-up for frequencies 1-40GHz was placed on top of the 1.5 meter high, 1 x 1.5 meter table. The EUT, support equipment, and interconnecting cables were arranged and manipulated to maximize each emission. Appropriate precaution was taken to ensure that all emissions from the EUT were maximized and investigated. The system configuration, clock speed, mode of operation or video resolution, if applicable, turntable azimuth, and receive antenna height was noted for each frequency found.

Final measurements were made in the semi-anechoic chamber using calibrated, linearly polarized broadband and horn antennas. The test setup was configured to the setup that produced the worst case emissions. The spectrum analyzer was set to investigate all frequencies required for testing to compare the highest radiated disturbances with respect to the specified limits. The turntable containing the EUT was rotated through 360 degrees and the height of the receive antenna was varied 1 to 4 meters and stopped at the azimuth and height producing the maximum emission. Each emission was maximized by changing the orientation of the EUT through three orthogonal planes and changing the polarity of the receive antenna, whichever produced the worst-case emissions. According to 3dB Beam-Width of horn antenna, the horn antenna should be always directed to the EUT when rising height.

## 4. ANTENNA REQUIREMENTS

### **Excerpt from §15.203 of the FCC Rules/Regulations:**

“An intentional radiator antenna shall be designed to ensure that no antenna other than that furnished by the responsible party can be used with the device. The use of a permanently attached antenna or of an antenna that uses a unique coupling to the intentional radiator shall be considered sufficient to comply with the provisions of this section.”

- The antenna of the **Mantis Q Remote Controller** is **permanently attached**.
- There are no provisions for connection to an external antenna.

### **Conclusion:**

The unit complies with the requirement of §15.203.

## 5. TEST EQUIPMENT CALIBRATION DATE

### Conducted Emissions - SR1

Instrument	Manufacturer	Type No.	Asset No.	Cali. Interval	Cali. Due Date
EMI Test Receiver	R&S	ESR3	MRTTWA00045	1 year	2019/03/17
Two-Line V-Network	R&S	ENV216	MRTTWA00019	1 year	2019/03/23
Two-Line V-Network	R&S	ENV216	MRTTWA00020	1 year	2019/03/23
Temperature/Humidity Meter	TFA	35.1078.10.IT	MRTTWA00033	1 year	2019/06/07

### Radiated Emissions - AC1

Instrument	Manufacturer	Type No.	Asset No.	Cali. Interval	Cali. Due Date
Signal Analyzer	R&S	FSV40	MRTTWA00007	1 year	2019/03/02
EMI Test Receiver	R&S	ESR3	MRTTWA00009	1 year	2019/03/16
Broadband Preamplifier	SCHWARZBECK	BBV 9718	MRTTWA00005	1 year	2019/04/06
Broadband Amplifier	SCHWARZBECK	BBV 9721	MRTTWA00006	1 year	2019/04/06
Active Loop Antenna	SCHWARZBECK	FMZB 1519B	MRTTWA00002	1 year	2019/04/06
Broadband TRILOG Antenna	SCHWARZBECK	VULB 9162	MRTTWA00001	1 year	2019/04/06
Broadband Hornantenna	SCHWARZBECK	BBHA 9120D	MRTTWA00003	1 year	2019/04/06
Breitband Hornantenna	SCHWARZBECK	BBHA 9170	MRTTWA00004	1 year	2019/04/06
Temperature/Humidity Meter	TFA	35.1078.10.IT	MRTTWA00033	1 year	2019/06/07

### Conducted Test Equipment - SR1

Instrument	Manufacturer	Type No.	Asset No.	Cali. Interval	Cali. Due Date
EXA Signal Analyzer	KEYSIGHT	N9010A	MRTTWA00012	1 year	2018/07/10
X-Series USB Peak and Average Power Sensor	KEYSIGHT	U2021XA	MRTTWA00014	1 year	2019/03/18
X-Series USB Peak and Average Power Sensor	KEYSIGHT	U2021XA	MRTTWA00015	1 year	2019/03/18
Programmable Temperature & Humidity Chamber	TEN BILLION	TTH-B3UP	MRTTWA00036	1 year	2019/05/10
Temperature/Humidity Meter	TFA	35.1078.10.IT	MRTTWA00033	1 year	2019/06/07

Software	Version	Function
e3	V 8.3.5	EMI Test Software

## 6. MEASUREMENT UNCERTAINTY

Where relevant, the following test uncertainty levels have been estimated for tests performed on the EUT as specified in CISPR 16-4-2. This uncertainty represents an expanded uncertainty expressed at approximately the 95% confidence level using a coverage factor of  $k = 2$ .

<b>AC Conducted Emission Measurement - SR1</b>
Measuring Uncertainty for a Level of Confidence of 95% ( $U=2Uc(y)$ ): 150kHz~30MHz: 3.46dB
<b>Radiated Emission Measurement - AC1</b>
Measuring Uncertainty for a Level of Confidence of 95% ( $U=2Uc(y)$ ): 9kHz ~ 1GHz: 4.18dB 1GHz ~ 40GHz: 4.76dB



## 7. TEST RESULT

### 7.1. Summary

**Company Name:** Yuneec Technology Co., Limited  
**FCC ID:** 2ACS5-YUNMQRC  
**IC:** 11554B-YUNMQRC

FCC Section(s)	Test Description	Test Limit	Test Condition	Test Result	Reference
15.407(a)	26dB Bandwidth	N/A	Conducted	Pass	Section 7.2
15.407(e)	6dB Bandwidth	≥ 500kHz		Pass	Section 7.3
15.407(a)(1)(iv), (3)	Maximum Conducted Output Power	Refer to section 7.4		Pass	Section 7.4
15.407(a)(1)(iv), (3), (5)	Peak Power Spectral Density	Refer to section 7.5		Pass	Section 7.5
15.407(g)	Frequency Stability	N/A		Pass	Section 7.6
15.407(b)(1), (4)(i)	Undesirable Emissions	≤ -27dBm/MHz EIRP Detail see section 7.8	Radiated	Pass	Section 7.7 & 7.8
15.205, 15.209 15.407(b)(5), (6), (7)	General Field Strength Limits (Restricted Bands and Radiated Emission Limits)	Emissions in restricted bands must meet the radiated limits detailed in 15.209		Pass	
15.207	AC Conducted Emissions 150kHz - 30MHz	< FCC 15.207 limits	Line Conducted	Pass	Section 7.9

RSS Section(s)	Test Description	Test Limit	Test Condition	Test Result	Reference
RSS-247 §6.2	99% Bandwidth	N/A	Conducted	Pass	Section 7.2
RSS-247 §6.2.4	6dB Bandwidth	>500kHz		Pass	Section 7.3
RSS-247 §6.2.4	Max Conducted Output Power	Refer to section 7.4		Pass	Section 7.4
RSS-247 §6.2.4	Peak Power Spectral Density	Refer to section 7.5		Pass	Section 7.5
RSS-Gen [8.11]	Frequency Stability	N/A		Pass	Section 7.6
RSS-247 §6.2.4	Out-of-Band Emissions	Refer to section 7.8	Radiated	Pass	Section 7.7 & 7.8
RSS-247 §6.2.4	General Field Strength Limits (Restricted Bands and Radiated Emission Limits)	Emissions in restricted bands must meet the radiated limits detailed in RSS-Gen [8.9]		Pass	
RSS-Gen [8.8]	AC Conducted Emissions 150kHz - 30MHz	≤ RSS-Gen [8.8] Limit	Line Conducted	Pass	Section 7.9

**Notes:**

- 1) All channels, modes, and modulations/data rates were investigated among all UNII bands. The test results shown in the following sections represent the worst case emissions.
- 2) The analyzer plots shown in this section were all taken with a correction table loaded into the analyzer. The correction table was used to account for the losses of the cables and attenuators used as part of the system to connect the EUT to the analyzer at all frequencies of interest.

## 7.2. 26dB Bandwidth Measurement

### 7.2.1. Test Limit

N/A

### 7.2.2. Test Procedure used

KDB 789033 D02v02r01 – Section C.1

### 7.2.3. Test Setting

1. The analyzers' automatic bandwidth measurement capability was used to perform the 26dB bandwidth measurement. The "X" dB bandwidth parameter was set to  $X = 26$ . The automatic bandwidth measurement function also has the capability of simultaneously measuring the 99% occupied bandwidth. The bandwidth measurement was not influenced by any intermediated power nulls in the fundamental emission.
2. RBW = approximately 1% of the emission bandwidth.
3. VBW  $\geq 3 \times$  RBW.
4. Detector = Peak.
5. Trace mode = max hold.

### 7.2.4. Test Setup

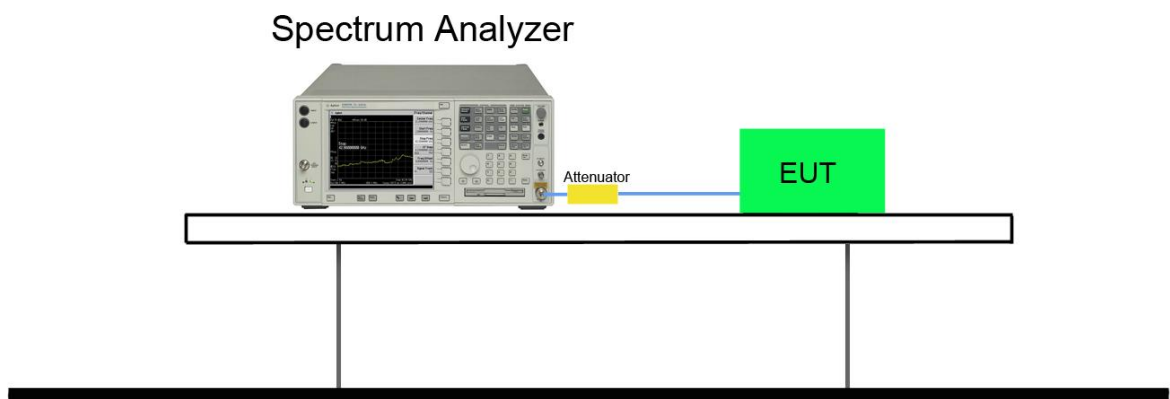

**7.2.5. Test Result**

Product	Mantis Q Remote Controller	Temperature	24°C
Test Engineer	Kevin Ker	Relative Humidity	59%
Test Site	SR1	Test Date	2018/04/13

Test Mode	Data Rate (Mbps)	Channel No.	Frequency (MHz)	26dB Bandwidth (MHz)	99% Bandwidth (MHz)
<b>Ant A</b>					
802.11a	6	36	5180	23.53	16.77
802.11a	6	44	5220	21.44	16.70
802.11a	6	48	5240	21.01	16.69
802.11a	6	149	5745	26.40	16.91
802.11a	6	157	5785	27.36	16.99
802.11a	6	165	5825	32.55	17.28
802.11n-HT20	MCS0	36	5180	22.31	17.83
802.11n-HT20	MCS0	44	5220	22.36	17.85
802.11n-HT20	MCS0	48	5240	22.50	17.87
802.11n-HT20	MCS0	149	5745	21.91	17.82
802.11n-HT20	MCS0	157	5785	22.75	17.89
802.11n-HT20	MCS0	165	5825	28.04	18.03

## 802.11a 26dB Bandwidth &amp; 99% Bandwidth - Ant A

## Channel 36 (5180MHz)

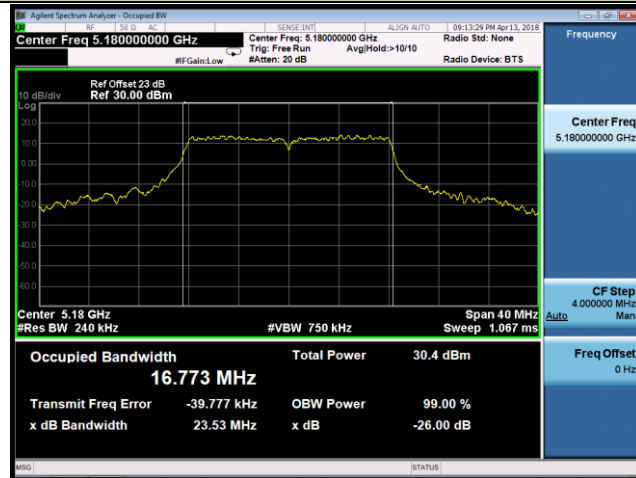

## Channel 44 (5220MHz)

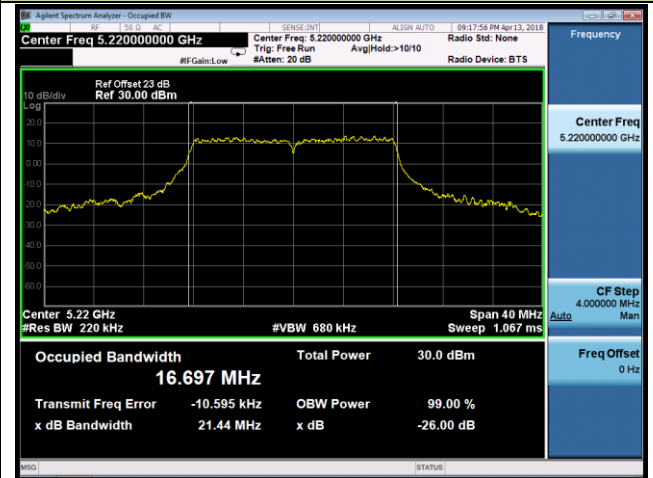

## Channel 48 (5240MHz)

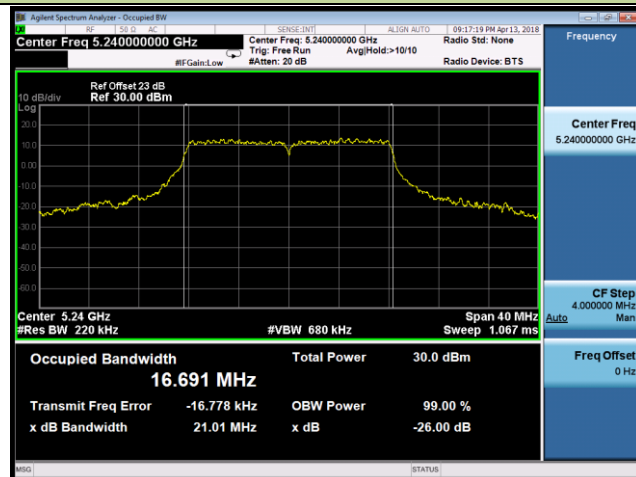

## Channel 149 (5745MHz)

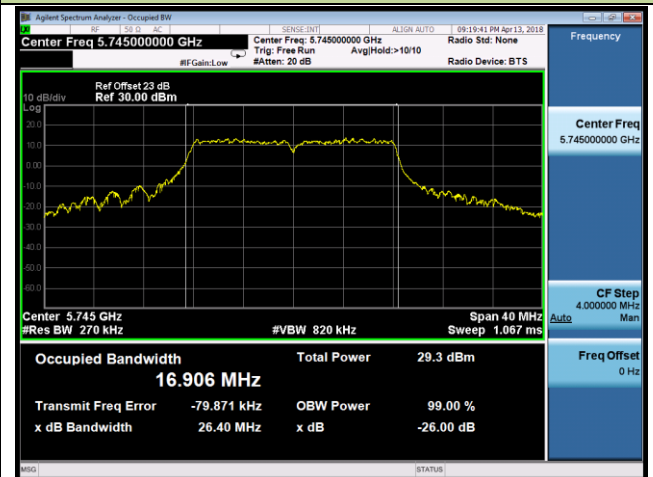

## Channel 157 (5785MHz)

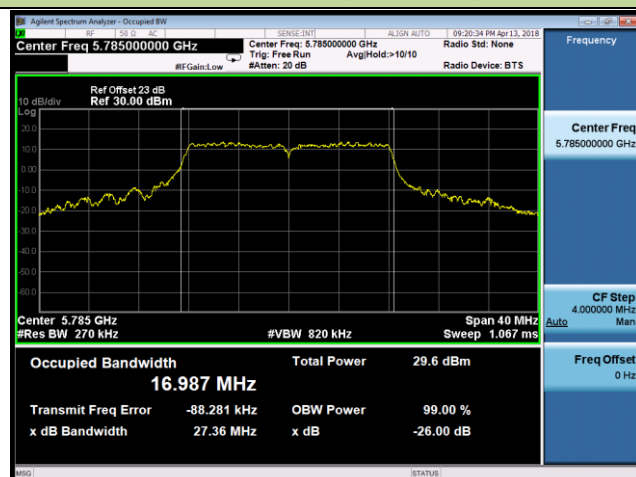

## Channel 165 (5825MHz)

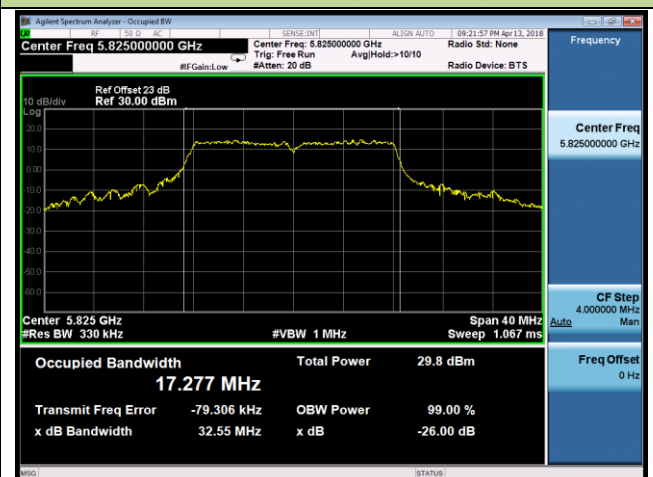

## 802.11n-HT20 26dB Bandwidth &amp; 99% Bandwidth - Ant A

## Channel 36 (5180MHz)

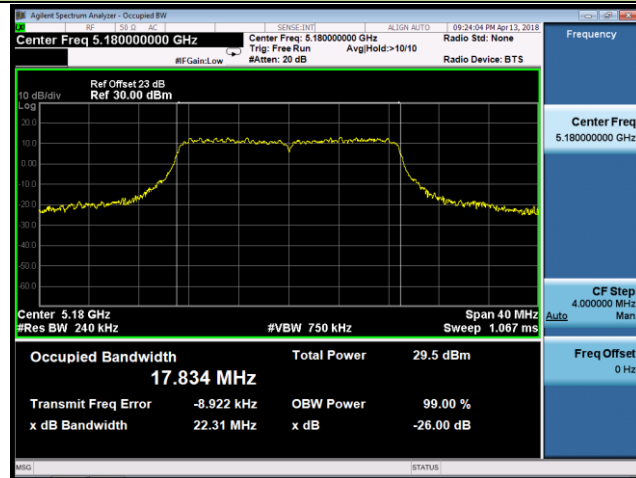

## Channel 44 (5220MHz)

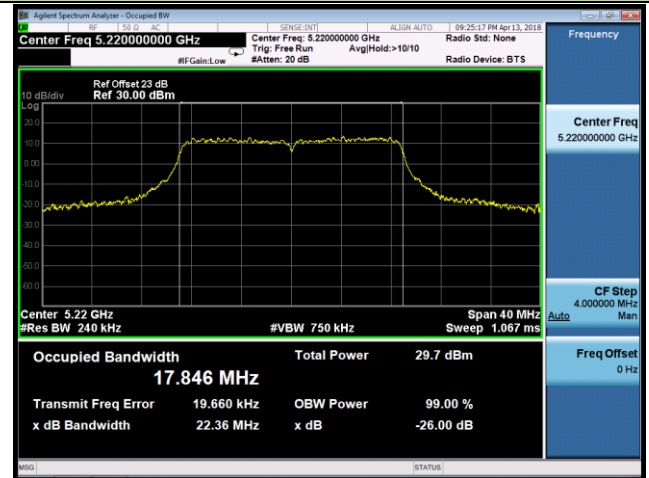

## Channel 48 (5240MHz)

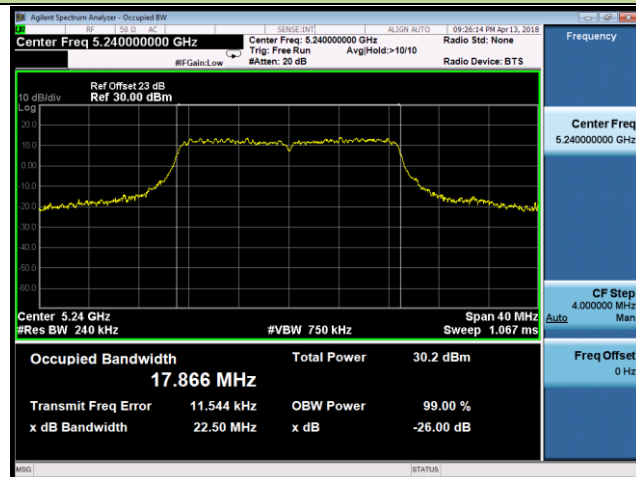

## Channel 149 (5745MHz)

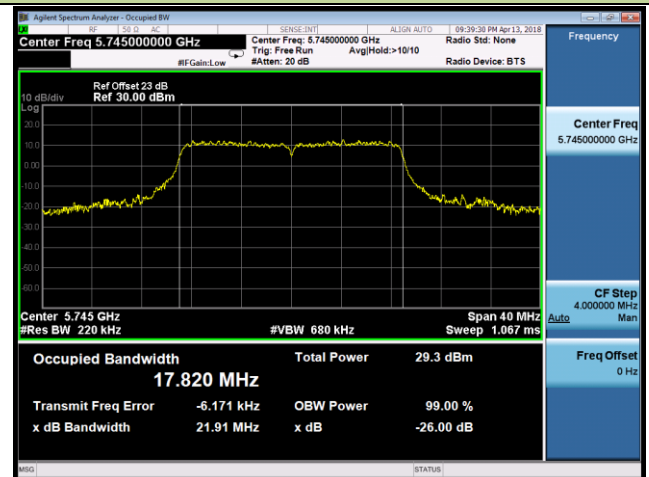

## Channel 157 (5785MHz)

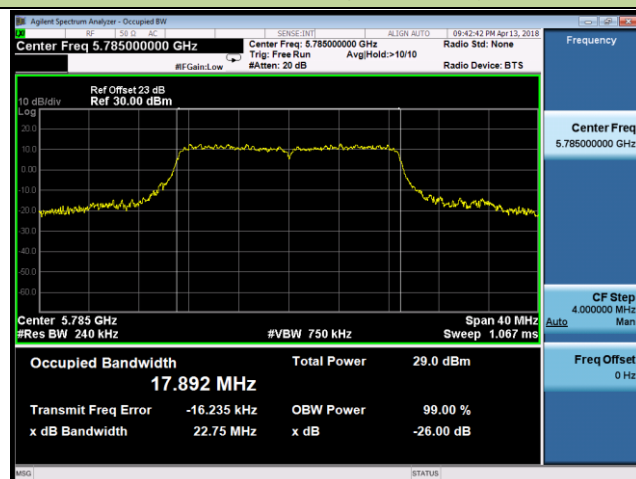

## Channel 165 (5825MHz)

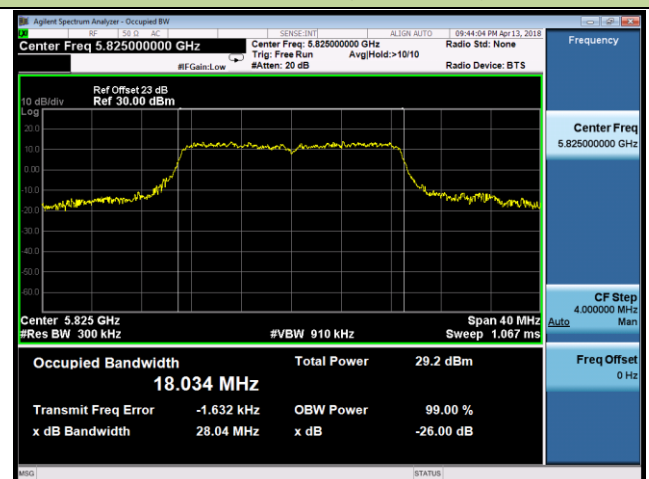

### 7.3. 6dB Bandwidth Measurement

#### 7.3.1. Test Limit

The minimum 6dB bandwidth shall be at least 500 kHz.

#### 7.3.2. Test Procedure used

KDB 789033 D02v02r01 – Section C.2

#### 7.3.3. Test Setting

1. Set center frequency to the nominal EUT channel center frequency.
2. RBW = 100 kHz.
3. VBW  $\geq 3 \times$  RBW.
4. Detector = Peak.
5. Trace mode = max hold.
6. Sweep = auto couple.
7. Allow the trace to stabilize.
8. Measure the maximum width of the emission that is constrained by the frequencies associated with the two outermost amplitude points (upper and lower frequencies) that are attenuated by 6 dB relative to the maximum level measured in the fundamental emission.

#### 7.3.4. Test Setup

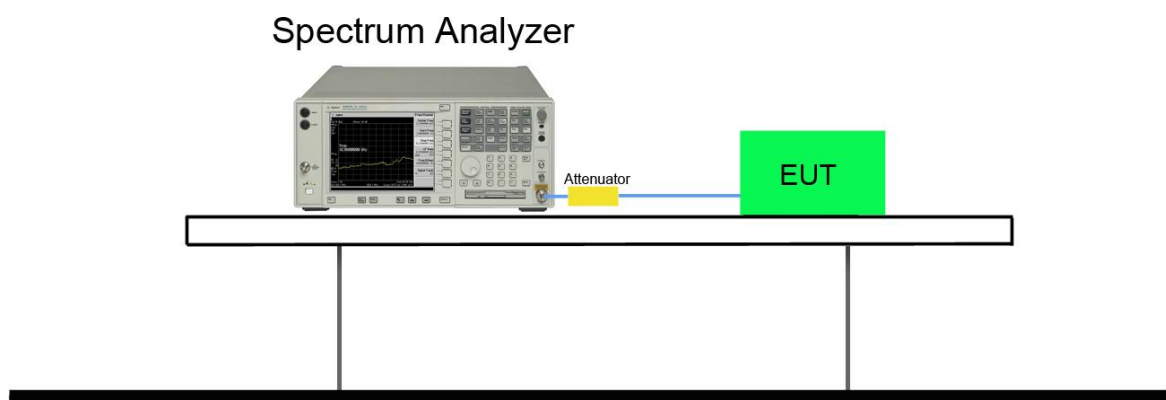

**7.3.5. Test Result**

Product	Mantis Q Remote Controller	Temperature	24°C
Test Engineer	Kevin Ker	Relative Humidity	59%
Test Site	SR1	Test Date	2018/04/13

Test Mode	Data Rate (Mbps)	Channel No.	Frequency (MHz)	6dB Bandwidth (MHz)	Limit (MHz)	Result
Ant A						
802.11a	6	149	5745	16.57	≥ 0.5	Pass
802.11a	6	157	5785	16.56	≥ 0.5	Pass
802.11a	6	165	5825	16.56	≥ 0.5	Pass
802.11n-HT20	MCS0	149	5745	17.69	≥ 0.5	Pass
802.11n-HT20	MCS0	157	5785	17.74	≥ 0.5	Pass
802.11n-HT20	MCS0	165	5825	17.78	≥ 0.5	Pass



802.11a 6dB Bandwidth - Ant A

Channel 149 (5745MHz)

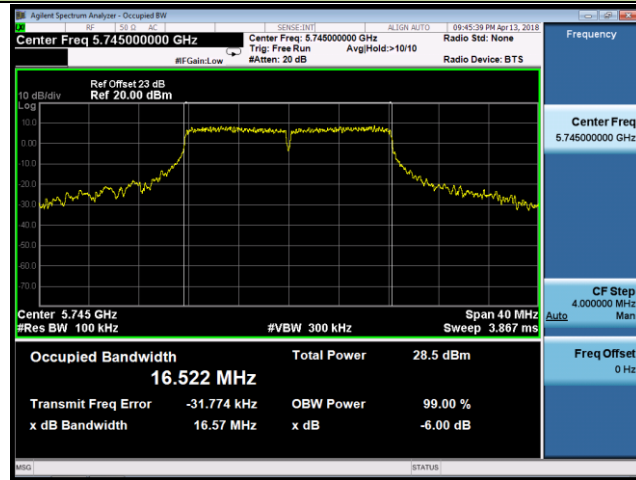

Channel 157 (5785MHz)

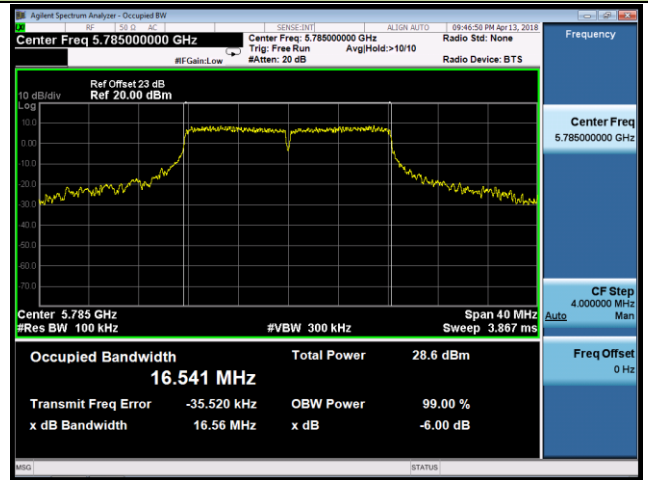

Channel 165 (5825MHz)

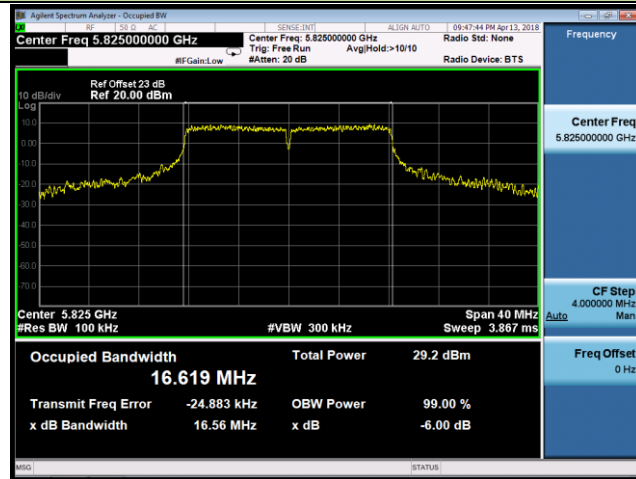

## 802.11n-HT20 6dB Bandwidth - Ant A

## Channel 149 (5745MHz)

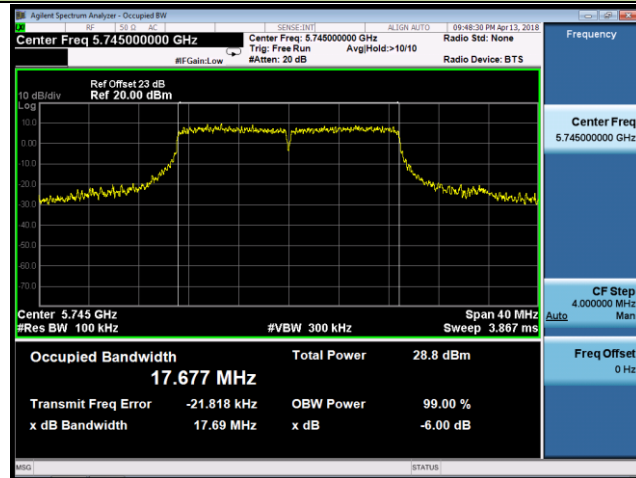

## Channel 157 (5785MHz)

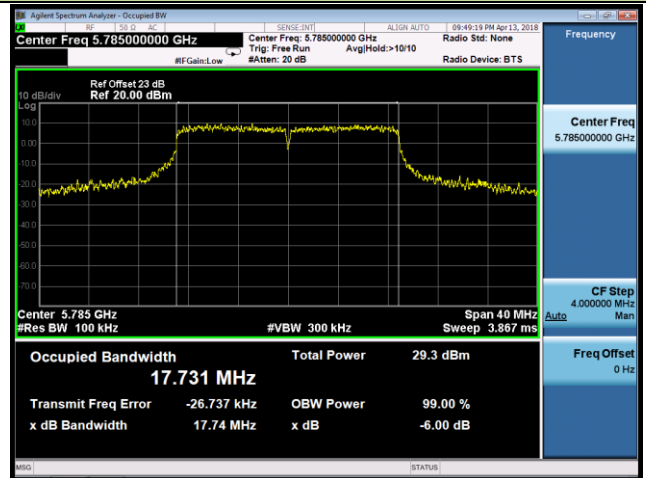

## Channel 165 (5825MHz)

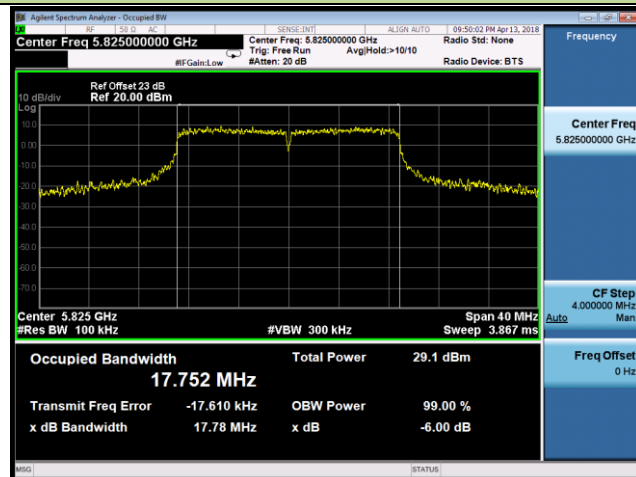

## **7.4. Output Power Measurement**

### **7.4.1. Test Limit**

#### **For FCC**

For client devices in the 5.15-5.25 GHz band, the maximum conducted output power over the frequency band of operation shall not exceed 250 mW provided the maximum antenna gain does not exceed 6 dBi.

For the band 5.725-5.85 GHz, the maximum conducted output power over the frequency band of operation shall not exceed 1 W (30dBm). If transmitting antennas of directional gain greater than 6 dBi are used, the maximum conducted output power shall be reduced by the amount in dB that the directional gain of the antenna exceeds 6 dBi.

#### **For IC**

For the 5.725-5.85 GHz band, the maximum conducted output power shall not exceed 1 W.

If transmitting antennas of directional gain greater than 6dBi are used, the maximum conducted output power shall be reduced by the amount in dB that the directional gain of the antenna exceeds 6dBi.

### **7.4.2. Test Procedure Used**

KDB 789033 D02v02r01 - Section E) 3) b) Method PM-G

### **7.4.3. Test Setting**

Average power measurements were performed only when the EUT was transmitting at its maximum power control level using a broadband power meter with a pulse sensor. The power meter implemented triggering and gating capabilities which were set up such that power measurements were recorded only during the ON time of the transmitter.

### 7.4.4. Test Setup



### 7.4.5. Test Result

Power output test was verified over all data rates of each mode shown as below table, and then choose the maximum power output (Gray Marker) for final test of each channel.

#### Output power at various data rates for Ant A port:

Test Mode	Frequency (MHz)	Data Rate (Mbps)	Average Power (dBm)
802.11a	5180	6	21.76
		24	21.31
		54	20.83
802.11n-HT20	5180	MCS0	22.04
		MCS3	21.61
		MCS7	21.04

Product	Mantis Q Remote Controller	Temperature	22°C
Test Engineer	Kevin Ker	Relative Humidity	54%
Test Site	SR1	Test Date	2018/04/13 ~ 2018/04/23
Test Item	FCC & IC Output Power		

Test Mode	Data Rate (Mbps)	Channel No.	Freq. (MHz)	Average Power (dBm)	Average Power Limit (dBm)	Result
Ant A						
802.11a	6	36	5180	21.76	≤ 23.98	Pass
802.11a	6	44	5220	21.92	≤ 23.98	Pass
802.11a	6	48	5240	22.01	≤ 23.98	Pass
802.11a	6	149	5745	21.35	≤ 30.00	Pass
802.11a	6	157	5785	21.93	≤ 30.00	Pass
802.11a	6	165	5825	22.36	≤ 30.00	Pass
802.11n-HT20	MCS0	149	5180	22.04	≤ 23.98	Pass
802.11n-HT20	MCS0	157	5220	21.80	≤ 23.98	Pass
802.11n-HT20	MCS0	165	5240	21.96	≤ 23.98	Pass
802.11n-HT20	MCS0	149	5745	21.04	≤ 30.00	Pass
802.11n-HT20	MCS0	157	5785	22.18	≤ 30.00	Pass
802.11n-HT20	MCS0	165	5825	22.05	≤ 30.00	Pass

## 7.5. Power Spectral Density Measurement

### 7.5.1. Test Limit

#### For FCC

For client devices in the 5.15-5.25 GHz band, the maximum power spectral density shall not exceed 11 dBm in any 1 megahertz band.

For the band 5.725-5.85 GHz, the maximum power spectral density shall not exceed 30 dBm in any 500-kHz band.

If transmitting antennas of directional gain greater than 6dBi are used, the peak power spectral density shall be reduced by the amount in dB that the directional gain of the antenna exceeds 6dBi.

#### For IC

For the 5.725-5.85 GHz band, the power spectral density shall not exceed 30 dBm in any 500 kHz band.

If transmitting antennas of directional gain greater than 6dBi are used, the peak power spectral density shall be reduced by the amount in dB that the directional gain of the antenna exceeds 6dBi.

### 7.5.2. Test Procedure Used

KDB 789033 D02v02r01 - Section F

### 7.5.3. Test Setting

1. Analyzer was set to the center frequency of the UNII channel under investigation
2. Span was set to encompass the entire 26dB OBW of the signal.
3. RBW = 1MHz, if measurement bandwidth of Maximum PSD is specified in 500 kHz,  
RBW = 100 kHz
4. VBW = 3MHz
5. Number of sweep points  $\geq 2 \times (\text{span} / \text{RBW})$
6. Detector = power averaging (RMS)
7. Sweep time = auto
8. Trigger = free run
9. Use the peak search function on the instrument to find the peak of the spectrum and record its value.
10. Add  $10 \cdot \log(1/x)$ , where x is the duty cycle, to the measured power in order to compute the average power during the actual transmission times (because the measurement represents an

average over both the on and off times of the transmission). For example, add  $10 \cdot \log(1/0.25) = 6$  dB if the duty cycle is 25 percent.

11. When the measurement bandwidth of Maximum PSD is specified in 500 kHz, add a constant factor  $10 \cdot \log(500\text{kHz}/100\text{kHz}) = 6.99$  dB to the measured result.

#### 7.5.4. Test Setup

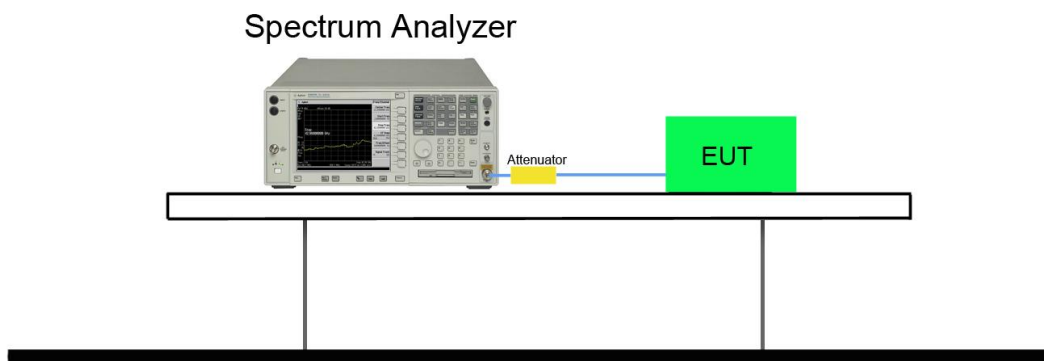

**7.5.5. Test Result**

Product	Mantis Q Remote Controller	Temperature	24°C
Test Engineer	Kevin Ker	Relative Humidity	59%
Test Site	SR1	Test Date	2018/04/13 ~ 2018/04/23
Test Item	Power Spectral Density (FCC NII-Band1)		

Test Mode	Data Rate (Mbps)	Channel No.	Freq. (MHz)	PSD (dBm/MHz)	Duty Cycle (%)	Final PSD (dBm/MHz)	PSD Limit (dBm/MHz)	Result
Ant A								
802.11a	6	36	5180	10.17	94.70	10.41	≤ 11	Pass
802.11a	6	44	5220	10.64	94.70	10.88	≤ 11	Pass
802.11a	6	48	5240	10.46	94.70	10.70	≤ 11	Pass
802.11n-HT20	MCS0	36	5180	10.51	94.54	10.75	≤ 11	Pass
802.11n-HT20	MCS0	44	5220	10.57	94.54	10.81	≤ 11	Pass
802.11n-HT20	MCS0	48	5240	10.41	94.54	10.65	≤ 11	Pass

Note: When EUT duty cycle < 98%, the Final PSD (dBm/MHz) = PSD (dBm/MHz) + 10\*log (1/Duty Cycle).

Product	Mantis Q Remote Controller	Temperature	24°C
Test Engineer	Kevin Ker	Relative Humidity	59%
Test Site	SR1	Test Date	2018/04/13 ~ 2018/04/23
Test Item	Power Spectral Density (FCC & IC NII-Band 3)		

Test Mode	Data Rate (Mbps)	Channel No.	Freq. (MHz)	PSD (dBm/100kHz)	Duty Cycle (%)	Constant Factor	Final PSD (dBm/500kHz)	Limit (dBm/500kHz)	Result
Ant A									
802.11a	6	149	5745	4.35	94.70	6.99	11.58	≤ 30.00	Pass
802.11a	6	157	5785	3.66	94.70	6.99	10.89	≤ 30.00	Pass
802.11a	6	165	5825	4.13	94.70	6.99	11.36	≤ 30.00	Pass
802.11n-HT20	MCS0	149	5745	3.10	94.54	6.99	10.33	≤ 30.00	Pass
802.11n-HT20	MCS0	157	5785	3.49	94.54	6.99	10.72	≤ 30.00	Pass
802.11n-HT20	MCS0	165	5825	3.52	94.54	6.99	10.75	≤ 30.00	Pass

Note: When EUT duty cycle < 98%, the Final PSD (dBm/500kHz) = PSD (dBm/100kHz) + Constant Factor + 10\*log (1/Duty Cycle).



## 802.11a Power Spectral Density - Ant A

Channel 36 (5180MHz)

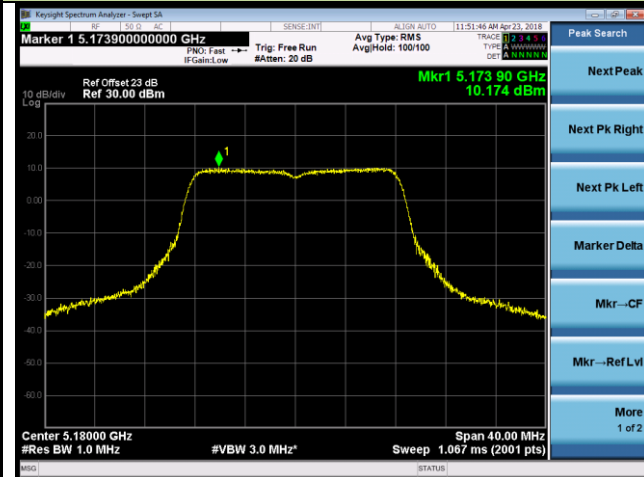

Channel 44 (5220MHz)

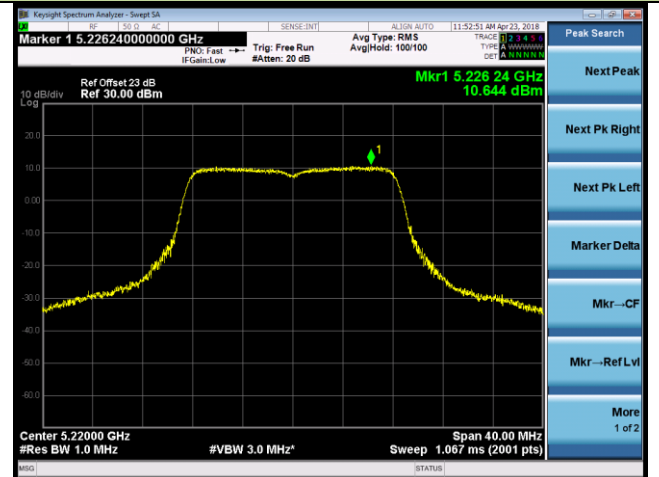

Channel 48 (5240MHz)

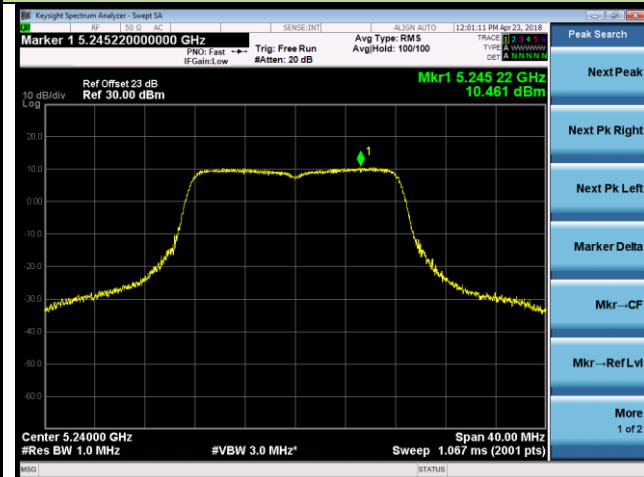

Channel 149 (5745MHz)

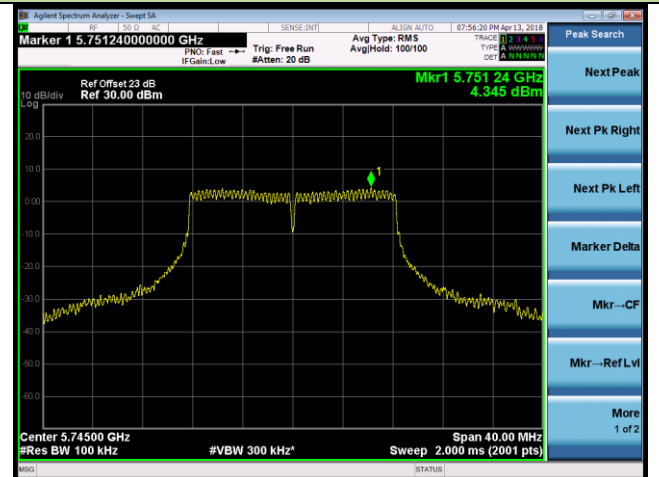

Channel 157 (5785MHz)

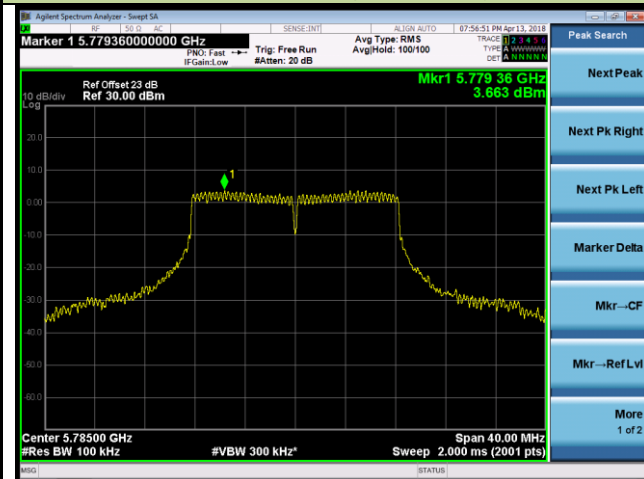

Channel 165 (5825MHz)

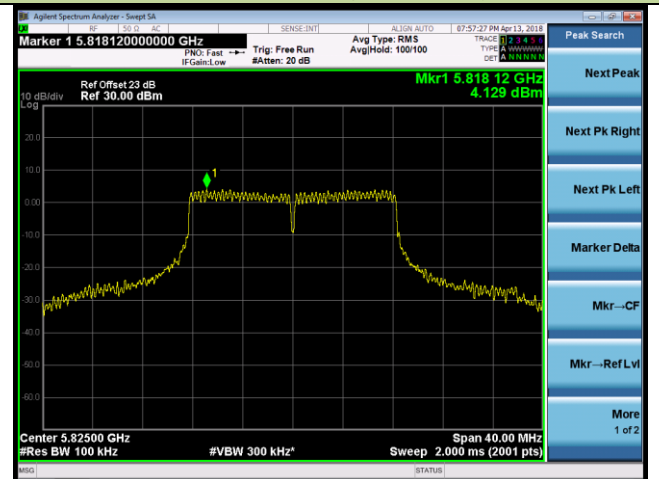

## 802.11n-HT20 Power Spectral Density - Ant A

Channel 36 (5180MHz)

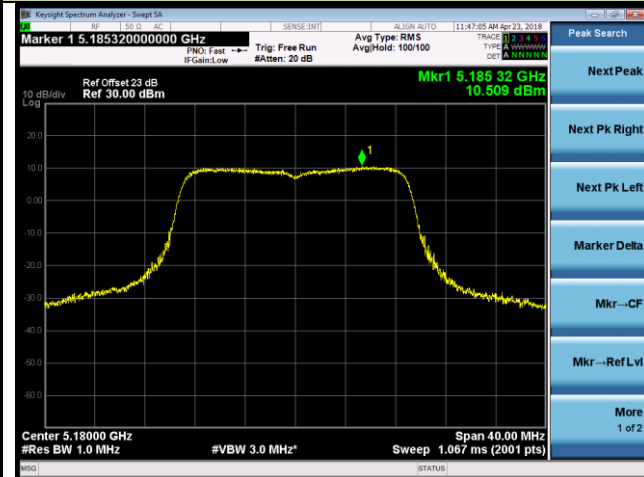

Channel 44 (5220MHz)

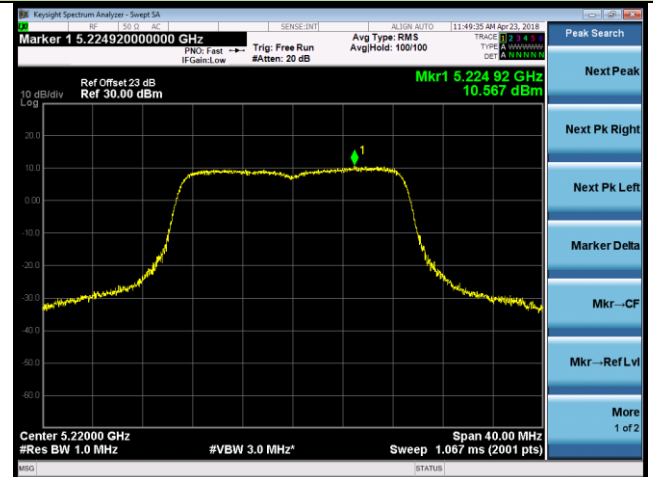

Channel 48 (5240MHz)

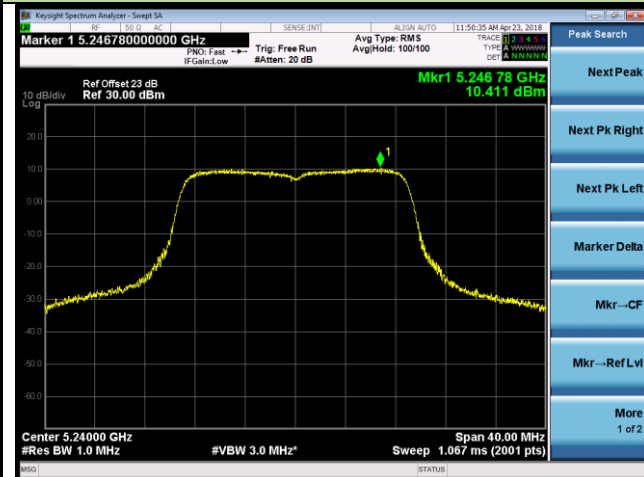

Channel 149 (5745MHz)

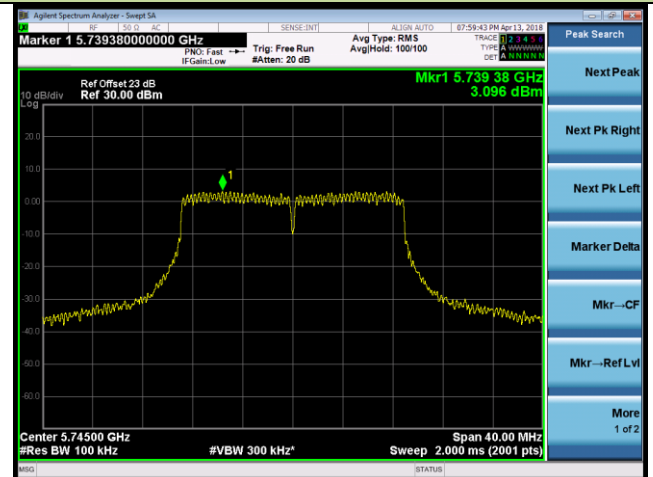

Channel 157 (5785MHz)

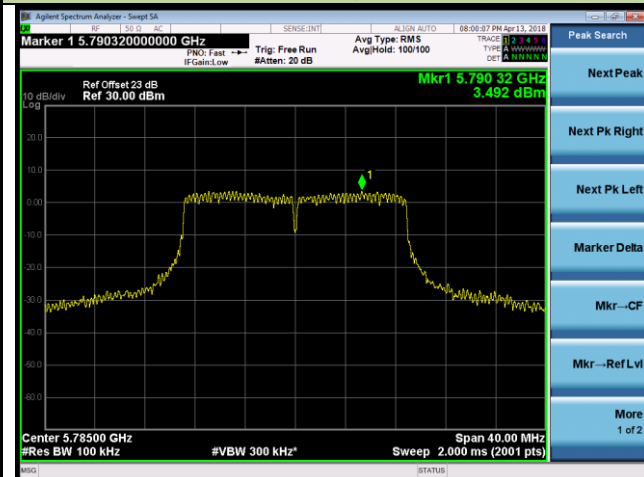

Channel 165 (5825MHz)

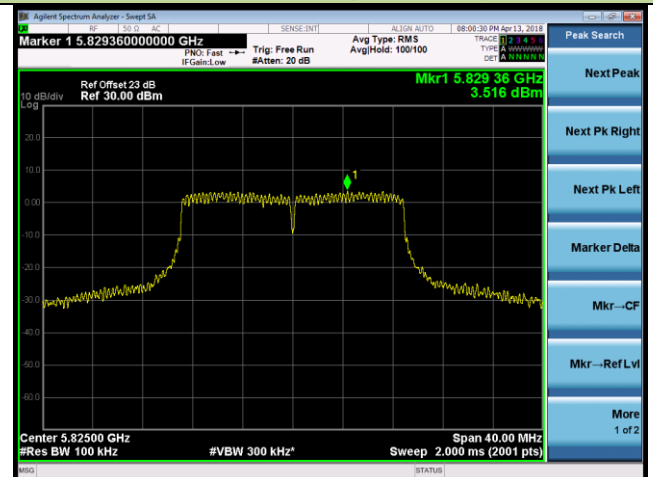

## **7.6. Frequency Stability Measurement**

### **7.6.1. Test Limit**

Manufactures of U-NII devices are responsible for ensuring frequency stability such that an emission is maintained within the band of operation under all conditions of normal operation as specified in the user's manual.

The transmitter center frequency tolerance shall be  $\pm 20$  ppm maximum for the 5GHz band (IEEE 802.11 specification).

### **7.6.2. Test Procedure Used**

#### **Frequency Stability Under Temperature Variations:**

The equipment under test was connected to an external AC or DC power supply and input rated voltage. RF output was connected to a frequency counter or spectrum analyzer via feed through attenuators. The EUT was placed inside the temperature chamber. Set the spectrum analyzer RBW low enough to obtain the desired frequency resolution and measure EUT 20°C operating frequency as reference frequency. Turn EUT off and set the chamber temperature to highest. After the temperature stabilized for approximately 30 minutes recorded the frequency. Repeat step measure with 10°C decreased per stage until the lowest temperature reached.

#### **Frequency Stability Under Voltage Variations:**

Set chamber temperature to 20°C. Use a variable AC power supply / DC power source to power the EUT and set the voltage to rated voltage. Set the spectrum analyzer RBW low enough to obtain the desired frequency resolution and recorded the frequency.

Reduce the input voltage to specify extreme voltage variation ( $\pm 15\%$ ) and endpoint, record the maximum frequency change.

### 7.6.3. Test Setup

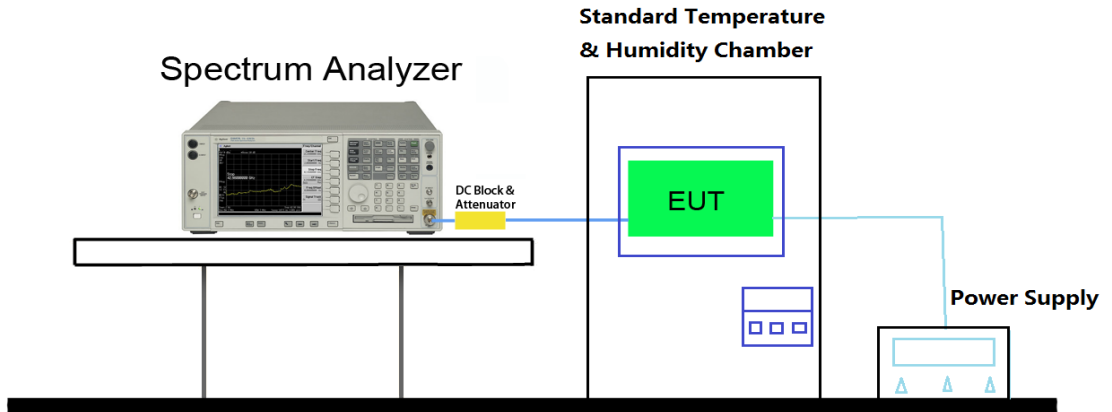

**7.6.4. Test Result**

Test Engineer	Kevin Ker	Temperature	-30 ~ 50°C
Test Time	2018/04/13	Relative Humidity	52%RH
Test Mode	5785MHz (Carrier Mode)	Test Site	SR1

Voltage (%)	Power (VDC)	Temp (°C)	Frequency Tolerance (ppm)			
			0 minutes	2 minutes	5 minutes	10 minutes
100%	3.7	- 30	-2.87	-2.14	-1.72	-1.28
		- 20	-3.74	-3.41	-2.57	-2.11
		- 10	-4.27	-3.44	-3.16	-2.42
		0	-3.98	-2.74	-2.83	-2.22
		+ 10	-3.86	-4.17	-2.47	-2.13
		+ 20 (Ref)	-4.37	-0.90	-0.69	-1.03
		+ 30	-5.23	-3.47	-3.35	-2.22
		+ 40	-5.14	-4.23	-3.21	-2.18
		+ 50	-5.98	-4.11	-4.19	-3.08
115%	4.26	+ 20	-4.77	-3.03	-2.75	-1.77
85%	3.15	+ 20	-3.88	-2.19	-1.96	-1.03

Note: Frequency Tolerance (ppm) =  $\frac{\{[\text{Measured Frequency (Hz)} - \text{Declared Frequency (Hz)}]\}}{\text{Declared Frequency (Hz)}} * 10^6$ .

## 7.7. Radiated Spurious Emission Measurement

### 7.7.1. Test Limit

All out of band emissions appearing in a restricted band as specified in Section 15.205 of the Title 47 CFR must not exceed the limits shown in Table per Section 15.209.

All out of band emissions appearing in a restricted band as specified in Section 8.10 of the RSS-Gen Issue 4 must not exceed the limits shown in Table per Section 8.9.

FCC Part 15 Subpart C Paragraph 15.209 & RSS-Gen Issue4 Section 8.9		
Frequency [MHz]	Field Strength [uV/m]	Measured Distance [Meters]
0.009 – 0.490	2400/F (kHz)	300
0.490 – 1.705	24000/F (kHz)	30
1.705 - 30	30	30
30 - 88	100	3
88 - 216	150	3
216 - 960	200	3
Above 960	500	3

### 7.7.2. Test Procedure Used

ANSI C63.10 Section 6.3 (General Requirements)

ANSI C63.10 Section 6.4 (Standard test method below 30MHz)

ANSI C63.10 Section 6.5 (Standard test method above 30MHz to 1GHz)

ANSI C63.10 Section 6.6 (Standard test method above 1GHz)

### **7.7.3. Test Setting**

#### **Quasi-Peak & Average Measurements below 30MHz**

1. Analyzer center frequency was set to the frequency of the radiated spurious emission of interest
2. Span was set greater than 1MHz
3. RBW = 200Hz for 9kHz to 150kHz frequency; RBW = 9kHz for 0.15MHz to 30MHz frequency
4. Detector = CISPR quasi-peak or power average (Average)
5. Sweep time = auto couple
6. Trace was allowed to stabilize

#### **Quasi-Peak Measurements below 1GHz**

1. Analyzer center frequency was set to the frequency of the radiated spurious emission of interest
2. Span was set greater than 1MHz
3. RBW = 120 kHz
4. Detector = CISPR quasi-peak
5. Sweep time = auto couple
6. Trace was allowed to stabilize

#### **Peak Measurements above 1GHz**

1. Analyzer center frequency was set to the frequency of the radiated spurious emission of interest
2. RBW = 1MHz
3. VBW = 3MHz
4. Detector = peak
5. Sweep time = auto couple
6. Trace mode = max hold
7. Trace was allowed to stabilize

### Average Measurements above 1GHz (Method AD)

1. Analyzer center frequency was set to the frequency of the radiated spurious emission of interest
2. RBW = 1MHz
3. VBW = 3MHz
4. Detector = power average (Average)
5. Number of measurement points = 1001 (Number of points must be  $> 2 \times \text{span}/\text{RBW}$ )
6. Sweep time = auto
7. Trace was averaged over at 100 sweeps

#### **7.7.4. Test Setup**

##### 9kHz ~ 30MHz Test Setup:

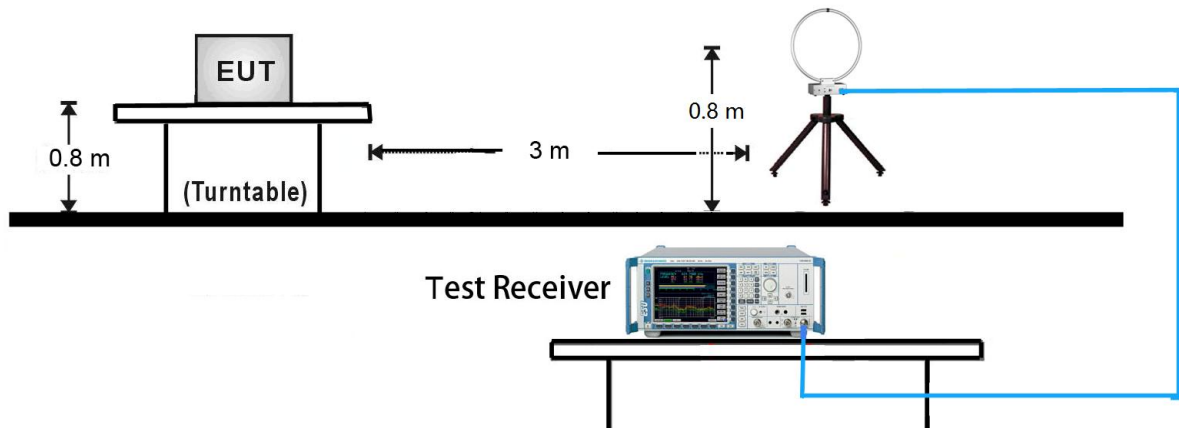

##### 30MHz ~ 1GHz Test Setup:

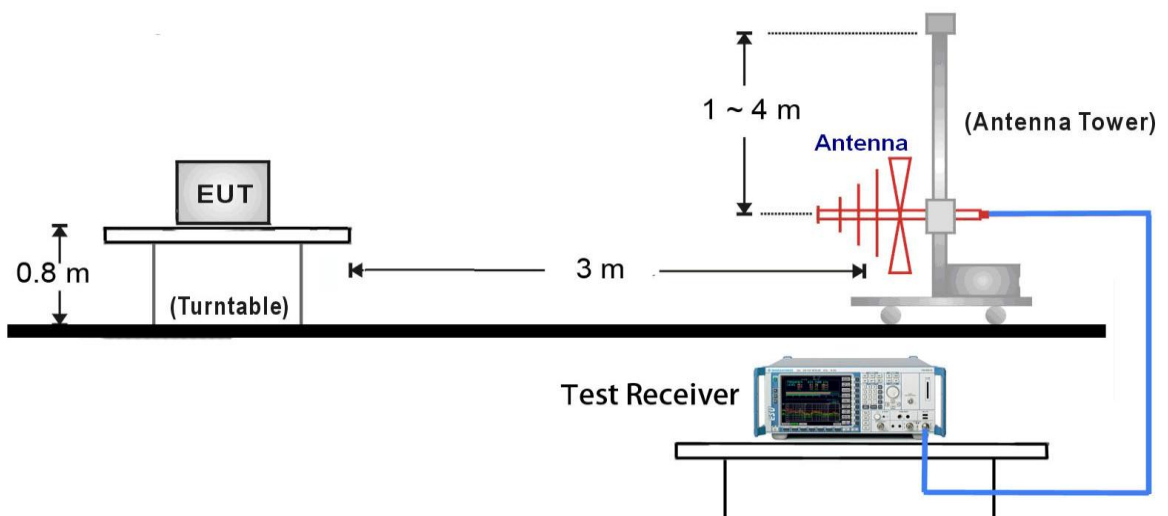



1GHz ~ 40GHz Test Setup:

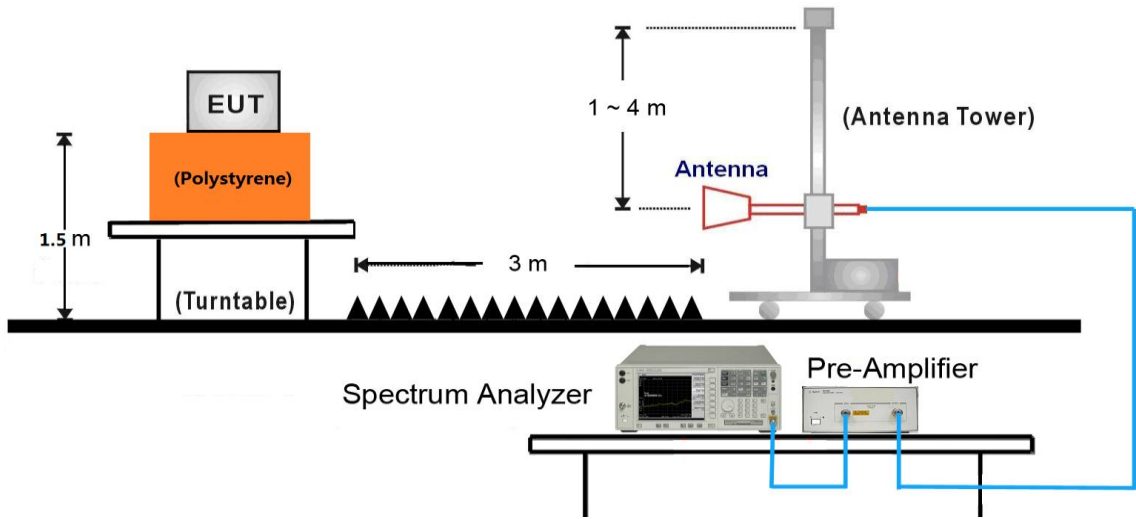

**7.7.5. Test Result**

Test Mode:	802.11a - Ant A	Test Site:	AC1
Test Channel:	36	Test Engineer:	Kevin Ker
Remark:	1. Average measurement was not performed if peak level lower than average limit. 2. Other frequency was 20dB below limit line within 1-18GHz, there is not show in the report.		

Mark	Frequency (MHz)	Reading Level (dBμV)	Factor (dB)	Measure Level (dBμV/m)	Limit (dBμV/m)	Margin (dB)	Detector	Polarization
*	7757.5	45.0	12.4	57.4	68.2	-10.8	Peak	Horizontal
*	10360.0	39.0	16.8	55.8	68.2	-12.4	Peak	Horizontal
	11098.0	32.9	18.6	51.5	74.0	-22.5	Peak	Horizontal
	11990.5	32.7	18.7	51.4	74.0	-22.6	Peak	Horizontal
*	7757.5	49.5	12.4	61.9	68.2	-6.3	Peak	Vertical
*	10360.0	41.8	16.8	58.6	68.2	-9.6	Peak	Vertical
	10877.0	33.5	18.2	51.7	74.0	-22.3	Peak	Vertical
	12636.5	33.0	18.7	51.7	74.0	-22.3	Peak	Vertical

Note 1: "\*" is not in restricted band, its limit is -27dBm/MHz. At a distance of 3 meters, the field strength limit in dBμV/m can be determined by adding a "conversion" factor of 95.2dB to the EIRP limit of -27dBm/MHz to obtain the limit for out of band spurious emissions.

Note 2: Measure Level (dBμV/m) = Reading Level (dBμV) + Factor (dB)

Factor (dB) = Cable Loss (dB) + Antenna Factor (dB/m) – Pre\_Amplifier Gain (dB)

Test Mode:	802.11a - Ant A	Test Site:	AC1
Test Channel:	44	Test Engineer:	Kevin Ker
Remark:	1. Average measurement was not performed if peak level lower than average limit. 2. Other frequency was 20dB below limit line within 1-18GHz, there is not show in the report.		

Mark	Frequency (MHz)	Reading Level (dB $\mu$ V)	Factor (dB)	Measure Level (dB $\mu$ V/m)	Limit (dB $\mu$ V/m)	Margin (dB)	Detector	Polarization
*	7757.5	44.9	12.4	57.3	68.2	-10.9	Peak	Horizontal
*	10440.0	38.1	17.1	55.2	68.2	-13.0	Peak	Horizontal
	11591.0	33.4	19.5	52.9	74.0	-21.1	Peak	Horizontal
	12458.0	32.7	18.4	51.1	74.0	-22.9	Peak	Horizontal
*	7757.5	44.4	12.4	56.8	68.2	-11.4	Peak	Vertical
*	10440.0	38.1	17.1	55.2	68.2	-13.0	Peak	Vertical
	11191.5	32.7	18.7	51.4	74.0	-22.6	Peak	Vertical
	12101.0	32.2	18.9	51.1	74.0	-22.9	Peak	Vertical

Note 1: "\*" is not in restricted band, its limit is -27dBm/MHz. At a distance of 3 meters, the field strength limit in dB $\mu$ V/m can be determined by adding a "conversion" factor of 95.2dB to the EIRP limit of -27dBm/MHz to obtain the limit for out of band spurious emissions.

Note 2: Measure Level (dB $\mu$ V/m) = Reading Level (dB $\mu$ V) + Factor (dB)

Factor (dB) = Cable Loss (dB) + Antenna Factor (dB/m) – Pre\_Amplifier Gain (dB)

Test Mode:	802.11a - Ant A	Test Site:	AC1
Test Channel:	48	Test Engineer:	Kevin Ker
Remark:	1. Average measurement was not performed if peak level lower than average limit. 2. Other frequency was 20dB below limit line within 1-18GHz, there is not show in the report.		

Mark	Frequency (MHz)	Reading Level (dBμV)	Factor (dB)	Measure Level (dBμV/m)	Limit (dBμV/m)	Margin (dB)	Detector	Polarization
*	7757.5	47.5	12.4	59.9	68.2	-8.3	Peak	Horizontal
*	10480.0	35.8	17.1	52.9	68.2	-15.3	Peak	Horizontal
	10741.0	35.4	17.6	53.0	74.0	-21.0	Peak	Horizontal
	11514.5	32.4	19.4	51.8	74.0	-22.2	Peak	Horizontal
*	7757.5	47.9	12.4	60.3	68.2	-7.9	Peak	Vertical
*	10480.0	39.4	17.1	56.5	68.2	-11.7	Peak	Vertical
	10868.5	33.6	18.2	51.8	74.0	-22.2	Peak	Vertical
	12118.0	32.2	18.9	51.1	74.0	-22.9	Peak	Vertical

Note 1: "\*" is not in restricted band, its limit is -27dBm/MHz. At a distance of 3 meters, the field strength limit in dBμV/m can be determined by adding a "conversion" factor of 95.2dB to the EIRP limit of -27dBm/MHz to obtain the limit for out of band spurious emissions.

Note 2: Measure Level (dBμV/m) = Reading Level (dBμV) + Factor (dB)

Factor (dB) = Cable Loss (dB) + Antenna Factor (dB/m) – Pre\_Amplifier Gain (dB)

Test Mode:	802.11a - Ant A	Test Site:	AC1
Test Channel:	149	Test Engineer:	Kevin Ker
Remark:	1. Average measurement was not performed if peak level lower than average limit. 2. Other frequency was 20dB below limit line within 1-18GHz, there is not show in the report.		

Mark	Frequency (MHz)	Reading Level (dBμV)	Factor (dB)	Measure Level (dBμV/m)	Limit (dBμV/m)	Margin (dB)	Detector	Polarization
*	7766.0	43.7	12.4	56.1	68.2	-12.1	Peak	Horizontal
*	10137.5	35.0	15.9	50.9	68.2	-17.3	Peak	Horizontal
	11490.0	45.3	19.3	64.6	74.0	-9.4	Peak	Horizontal
	11490.0	33.4	19.3	52.7	54.0	-1.3	Average	Horizontal
	12033.0	33.2	18.8	52.0	74.0	-22.0	Peak	Horizontal
*	7757.5	44.5	12.4	56.9	68.2	-11.3	Peak	Vertical
*	10392.5	34.5	16.9	51.4	68.2	-16.8	Peak	Vertical
	11490.0	39.3	19.3	58.6	74.0	-15.4	Peak	Vertical
	11490.0	28.8	19.3	48.1	54.0	-5.9	Average	Vertical
	12024.5	32.6	18.8	51.4	74.0	-22.6	Peak	Vertical

Note 1: "\*" is not in restricted band, its limit is -27dBm/MHz. At a distance of 3 meters, the field strength limit in dBμV/m can be determined by adding a "conversion" factor of 95.2dB to the EIRP limit of -27dBm/MHz to obtain the limit for out of band spurious emissions.

Note 2: Measure Level (dBμV/m) = Reading Level (dBμV) + Factor (dB)

Factor (dB) = Cable Loss (dB) + Antenna Factor (dB/m) – Pre\_Amplifier Gain (dB)

Test Mode:	802.11a - Ant A	Test Site:	AC1
Test Channel:	157	Test Engineer:	Kevin Ker
Remark:	1. Average measurement was not performed if peak level lower than average limit. 2. Other frequency was 20dB below limit line within 1-18GHz, there is not show in the report.		

Mark	Frequency (MHz)	Reading Level (dBμV)	Factor (dB)	Measure Level (dBμV/m)	Limit (dBμV/m)	Margin (dB)	Detector	Polarization
*	7757.5	45.3	12.4	57.7	68.2	-10.5	Peak	Horizontal
*	9789.0	35.5	15.0	50.5	68.2	-17.7	Peak	Horizontal
	11570.0	45.9	19.5	65.4	74.0	-8.6	Peak	Horizontal
	11570.0	33.6	19.5	53.1	54.0	-0.9	Average	Horizontal
	12356.0	32.7	18.4	51.1	74.0	-22.9	Peak	Horizontal
*	7757.5	44.0	12.4	56.4	68.2	-11.8	Peak	Vertical
*	10282.0	34.2	16.5	50.7	68.2	-17.5	Peak	Vertical
	11570.0	42.1	19.5	61.6	74.0	-12.4	Peak	Vertical
	11570.0	29.7	19.5	49.2	54.0	-4.8	Average	Vertical
	12466.5	33.2	18.5	51.7	74.0	-22.3	Peak	Vertical

Note 1: "\*" is not in restricted band, its limit is -27dBm/MHz. At a distance of 3 meters, the field strength limit in dBμV/m can be determined by adding a "conversion" factor of 95.2dB to the EIRP limit of -27dBm/MHz to obtain the limit for out of band spurious emissions.

Note 2: Measure Level (dBμV/m) = Reading Level (dBμV) + Factor (dB)

Factor (dB) = Cable Loss (dB) + Antenna Factor (dB/m) – Pre\_Amplifier Gain (dB)

Test Mode:	802.11a - Ant A	Test Site:	AC1
Test Channel:	165	Test Engineer:	Kevin Ker
Remark:	1. Average measurement was not performed if peak level lower than average limit. 2. Other frequency was 20dB below limit line within 1-18GHz, there is not show in the report.		

Mark	Frequency (MHz)	Reading Level (dBμV)	Factor (dB)	Measure Level (dBμV/m)	Limit (dBμV/m)	Margin (dB)	Detector	Polarization
*	7757.5	46.9	12.4	59.3	68.2	-8.9	Peak	Horizontal
*	10061.0	35.2	15.6	50.8	68.2	-17.4	Peak	Horizontal
	11650.0	45.9	19.4	65.3	74.0	-8.7	Peak	Horizontal
	11650.0	34.5	19.3	53.8	54.0	-0.2	Average	Horizontal
	12101.0	32.8	18.9	51.7	74.0	-22.3	Peak	Horizontal
*	7757.5	44.1	12.4	56.5	68.2	-11.7	Peak	Vertical
*	10078.0	34.7	15.6	50.3	68.2	-17.9	Peak	Vertical
	11650.0	44.2	19.3	63.5	74.0	-10.5	Peak	Vertical
	11650.0	30.7	19.3	50.0	54.0	-4.0	Average	Vertical
	12509.0	33.3	18.5	51.8	74.0	-22.2	Peak	Vertical

Note 1: "\*" is not in restricted band, its limit is -27dBm/MHz. At a distance of 3 meters, the field strength limit in dBμV/m can be determined by adding a "conversion" factor of 95.2dB to the EIRP limit of -27dBm/MHz to obtain the limit for out of band spurious emissions.

Note 2: Measure Level (dBμV/m) = Reading Level (dBμV) + Factor (dB)

Factor (dB) = Cable Loss (dB) + Antenna Factor (dB/m) – Pre\_Amplifier Gain (dB)

Test Mode:	802.11n-HT20 - Ant A	Test Site:	AC1
Test Channel:	36	Test Engineer:	Kevin Ker
Remark:	1. Average measurement was not performed if peak level lower than average limit. 2. Other frequency was 20dB below limit line within 1-18GHz, there is not show in the report.		

Mark	Frequency (MHz)	Reading Level (dBμV)	Factor (dB)	Measure Level (dBμV/m)	Limit (dBμV/m)	Margin (dB)	Detector	Polarization
*	7757.5	44.6	12.4	57.0	68.2	-11.2	Peak	Horizontal
*	10360.0	39.4	16.8	56.2	68.2	-12.0	Peak	Horizontal
	11395.5	33.0	19.1	52.1	74.0	-21.9	Peak	Horizontal
	12500.5	31.7	18.5	50.2	74.0	-23.8	Peak	Horizontal
*	7757.5	48.2	12.4	60.6	68.2	-7.6	Peak	Vertical
*	10360.0	39.8	16.8	56.6	68.2	-11.6	Peak	Vertical
	10953.5	33.1	18.4	51.5	74.0	-22.5	Peak	Vertical
	12126.5	32.5	18.9	51.4	74.0	-22.6	Peak	Vertical

Note 1: "\*" is not in restricted band, its limit is -27dBm/MHz. At a distance of 3 meters, the field strength limit in dBμV/m can be determined by adding a "conversion" factor of 95.2dB to the EIRP limit of -27dBm/MHz to obtain the limit for out of band spurious emissions.

Note 2: Measure Level (dBμV/m) = Reading Level (dBμV) + Factor (dB)

Factor (dB) = Cable Loss (dB) + Antenna Factor (dB/m) – Pre\_Amplifier Gain (dB)



Test Mode:	802.11n-HT20 - Ant A	Test Site:	AC1
Test Channel:	44	Test Engineer:	Kevin Ker
Remark:	1. Average measurement was not performed if peak level lower than average limit. 2. Other frequency was 20dB below limit line within 1-18GHz, there is not show in the report.		

Mark	Frequency (MHz)	Reading Level (dBμV)	Factor (dB)	Measure Level (dBμV/m)	Limit (dBμV/m)	Margin (dB)	Detector	Polarization
*	7757.5	46.4	12.4	58.8	68.2	-9.4	Peak	Horizontal
*	10440.0	36.1	17.1	53.2	68.2	-15.0	Peak	Horizontal
	11149.0	32.8	18.7	51.5	74.0	-22.5	Peak	Horizontal
	12135.0	32.2	18.9	51.1	74.0	-22.9	Peak	Horizontal
*	7766.0	47.4	12.4	59.8	68.2	-8.4	Peak	Vertical
*	10440.0	39.6	17.1	56.7	68.2	-11.5	Peak	Vertical
	10911.0	33.1	18.4	51.5	74.0	-22.5	Peak	Vertical
	12092.5	32.7	18.9	51.6	74.0	-22.4	Peak	Vertical

Note 1: "\*" is not in restricted band, its limit is -27dBm/MHz. At a distance of 3 meters, the field strength limit in dBμV/m can be determined by adding a "conversion" factor of 95.2dB to the EIRP limit of -27dBm/MHz to obtain the limit for out of band spurious emissions.

Note 2: Measure Level (dBμV/m) = Reading Level (dBμV) + Factor (dB)

Factor (dB) = Cable Loss (dB) + Antenna Factor (dB/m) – Pre\_Amplifier Gain (dB)

Test Mode:	802.11n-HT20 - Ant A	Test Site:	AC1
Test Channel:	48	Test Engineer:	Kevin Ker
Remark:	1. Average measurement was not performed if peak level lower than average limit. 2. Other frequency was 20dB below limit line within 1-18GHz, there is not show in the report.		

Mark	Frequency (MHz)	Reading Level (dBμV)	Factor (dB)	Measure Level (dBμV/m)	Limit (dBμV/m)	Margin (dB)	Detector	Polarization
*	7766.0	43.2	12.4	55.6	68.2	-12.6	Peak	Horizontal
*	10480.0	36.6	17.1	53.7	68.2	-14.5	Peak	Horizontal
	10979.0	33.2	18.5	51.7	74.0	-22.3	Peak	Horizontal
	11523.0	32.9	19.4	52.3	74.0	-21.7	Peak	Horizontal
*	7757.5	46.0	12.4	58.4	68.2	-9.8	Peak	Vertical
*	10480.0	38.8	17.1	55.9	68.2	-12.3	Peak	Vertical
	10860.0	33.4	18.2	51.6	74.0	-22.4	Peak	Vertical
	12109.5	32.4	18.9	51.3	74.0	-22.7	Peak	Vertical

Note 1: "\*" is not in restricted band, its limit is -27dBm/MHz. At a distance of 3 meters, the field strength limit in dBμV/m can be determined by adding a "conversion" factor of 95.2dB to the EIRP limit of -27dBm/MHz to obtain the limit for out of band spurious emissions.

Note 2: Measure Level (dBμV/m) = Reading Level (dBμV) + Factor (dB)

Factor (dB) = Cable Loss (dB) + Antenna Factor (dB/m) – Pre\_Amplifier Gain (dB)

Test Mode:	802.11n-HT20 - Ant A	Test Site:	AC1
Test Channel:	149	Test Engineer:	Kevin Ker
Remark:	1. Average measurement was not performed if peak level lower than average limit. 2. Other frequency was 20dB below limit line within 1-18GHz, there is not show in the report.		

Mark	Frequency (MHz)	Reading Level (dBμV)	Factor (dB)	Measure Level (dBμV/m)	Limit (dBμV/m)	Margin (dB)	Detector	Polarization
*	7757.5	44.2	12.4	56.6	68.2	-11.6	Peak	Horizontal
*	10137.5	34.6	15.9	50.5	68.2	-17.7	Peak	Horizontal
	11490.0	46.8	19.3	66.1	74.0	-7.9	Peak	Horizontal
	11490.0	33.9	19.3	53.2	54.0	-0.8	Average	Horizontal
	12228.5	32.5	18.7	51.2	74.0	-22.8	Peak	Horizontal
*	7757.5	43.7	12.4	56.1	68.2	-12.1	Peak	Vertical
*	9891.0	34.8	15.5	50.3	68.2	-17.9	Peak	Vertical
	11490.0	42.1	19.3	61.4	74.0	-12.6	Peak	Vertical
	11490.0	28.9	19.3	48.2	54.0	-5.8	Average	Vertical
	12628.0	32.2	18.7	50.9	74.0	-23.1	Peak	Vertical

Note 1: "\*" is not in restricted band, its limit is -27dBm/MHz. At a distance of 3 meters, the field strength limit in dBμV/m can be determined by adding a "conversion" factor of 95.2dB to the EIRP limit of -27dBm/MHz to obtain the limit for out of band spurious emissions.

Note 2: Measure Level (dBμV/m) = Reading Level (dBμV) + Factor (dB)

Factor (dB) = Cable Loss (dB) + Antenna Factor (dB/m) – Pre\_Amplifier Gain (dB)

Test Mode:	802.11n-HT20 - Ant A	Test Site:	AC1
Test Channel:	157	Test Engineer:	Kevin Ker
Remark:	1. Average measurement was not performed if peak level lower than average limit. 2. Other frequency was 20dB below limit line within 1-18GHz, there is not show in the report.		

Mark	Frequency (MHz)	Reading Level (dBμV)	Factor (dB)	Measure Level (dBμV/m)	Limit (dBμV/m)	Margin (dB)	Detector	Polarization
*	8701.0	33.4	13.8	47.2	68.2	-21.0	Peak	Horizontal
*	10146.0	34.8	16.0	50.8	68.2	-17.4	Peak	Horizontal
	11570.0	46.9	19.5	66.4	74.0	-7.6	Peak	Horizontal
	11570.0	34.4	19.5	53.9	54.0	-0.1	Average	Horizontal
	12177.5	32.2	18.8	51.0	74.0	-23.0	Peak	Horizontal
*	7757.5	45.3	12.4	57.7	68.2	-10.5	Peak	Vertical
*	10239.5	35.1	16.4	51.5	68.2	-16.7	Peak	Vertical
	11570.0	43.4	19.5	62.9	74.0	-11.1	Peak	Vertical
	11570.0	30.6	19.5	50.1	54.0	-3.9	Average	Vertical
	12033.0	33.0	18.8	51.8	74.0	-22.2	Peak	Vertical

Note 1: "\*" is not in restricted band, its limit is -27dBm/MHz. At a distance of 3 meters, the field strength limit in dBμV/m can be determined by adding a "conversion" factor of 95.2dB to the EIRP limit of -27dBm/MHz to obtain the limit for out of band spurious emissions.

Note 2: Measure Level (dBμV/m) = Reading Level (dBμV) + Factor (dB)

Factor (dB) = Cable Loss (dB) + Antenna Factor (dB/m) – Pre\_Amplifier Gain (dB)

Test Mode:	802.11n-HT20 - Ant A	Test Site:	AC1
Test Channel:	165	Test Engineer:	Kevin Ker
Remark:	1. Average measurement was not performed if peak level lower than average limit. 2. Other frequency was 20dB below limit line within 1-18GHz, there is not show in the report.		

Mark	Frequency (MHz)	Reading Level (dBμV)	Factor (dB)	Measure Level (dBμV/m)	Limit (dBμV/m)	Margin (dB)	Detector	Polarization
*	7757.5	45.8	12.4	58.2	68.2	-10.0	Peak	Horizontal
*	10401.0	34.1	16.9	51.0	68.2	-17.2	Peak	Horizontal
	11650.0	34.1	19.3	53.4	54.0	-0.6	Average	Horizontal
	11650.0	47.0	19.3	66.3	74.0	-7.7	Peak	Horizontal
	12092.5	33.1	18.9	52.0	74.0	-22.0	Peak	Horizontal
*	7766.0	44.4	12.4	56.8	68.2	-11.4	Peak	Vertical
*	9882.5	34.0	15.6	49.6	68.2	-18.6	Peak	Vertical
	11650.0	43.6	19.3	62.9	74.0	-11.1	Peak	Vertical
	11650.0	31.5	19.3	50.8	54.0	-3.2	Average	Vertical
	12143.5	32.3	18.9	51.2	74.0	-22.8	Peak	Vertical

Note 1: "\*" is not in restricted band, its limit is -27dBm/MHz. At a distance of 3 meters, the field strength limit in dBμV/m can be determined by adding a "conversion" factor of 95.2dB to the EIRP limit of -27dBm/MHz to obtain the limit for out of band spurious emissions.

Note 2: Measure Level (dBμV/m) = Reading Level (dBμV) + Factor (dB)

Factor (dB) = Cable Loss (dB) + Antenna Factor (dB/m) – Pre\_Amplifier Gain (dB)

**The worst case of Radiated Emission below 1GHz:**

Site: AC1	Time: 2018/04/18 - 11:10
Limit: FCC_Part15.209_RE(3m)	Engineer: Kevin Ker
Probe: VULB9162_0.03-8GHz	Polarity: Horizontal
EUT: Mantis Q Remote Controller	Power: By Battery
<b>Worse Case Mode:</b> Transmit by 802.11a at Channel 5180MHz Ant A	

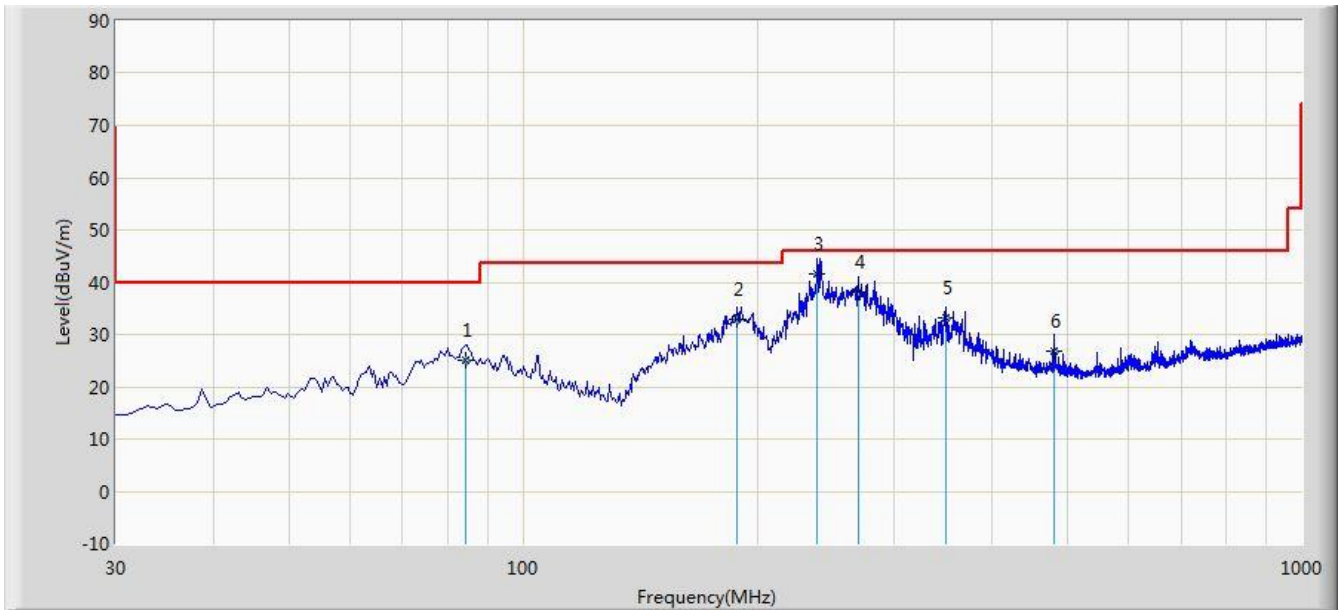

No	Flag	Mark	Frequency (MHz)	Measure Level (dBuV/m)	Reading Level (dBuV)	Over Limit (dB)	Limit (dBuV/m)	Factor (dB)	Type
1			84.320	25.078	15.028	-14.922	40.000	10.050	QP
2			188.595	32.935	21.125	-10.565	43.500	11.809	QP
3		*	239.035	41.662	28.125	-4.338	46.000	13.538	QP
4			269.105	38.256	24.038	-7.744	46.000	14.218	QP
5			348.645	33.244	17.221	-12.756	46.000	16.023	QP
6			480.080	26.897	8.664	-19.103	46.000	18.233	QP

Note 1: Measure Level (dBuV/m) = Reading Level (dBuV) + Factor (dB)

Factor (dB) = Cable Loss (dB) + Antenna Factor (dB/m)

Note 2: The test trace is same as the ambient noise and the amplitude of the emissions are attenuated more than 20dB below the permissible (the test frequency range: 9kHz ~ 30MHz, 18GHz ~ 25GHz), therefore no data appear in the report.

Site: AC1	Time: 2018/04/18 - 11:16
Limit: FCC_Part15.209_RE(3m)	Engineer: Kevin Ker
Probe: VULB9162_0.03-8GHz	Polarity: Vertical
EUT: Mantis Q Remote Controller	Power: By Battery
<b>Worse Case Mode:</b> Transmit by 802.11a at Channel 5180MHz Ant A	

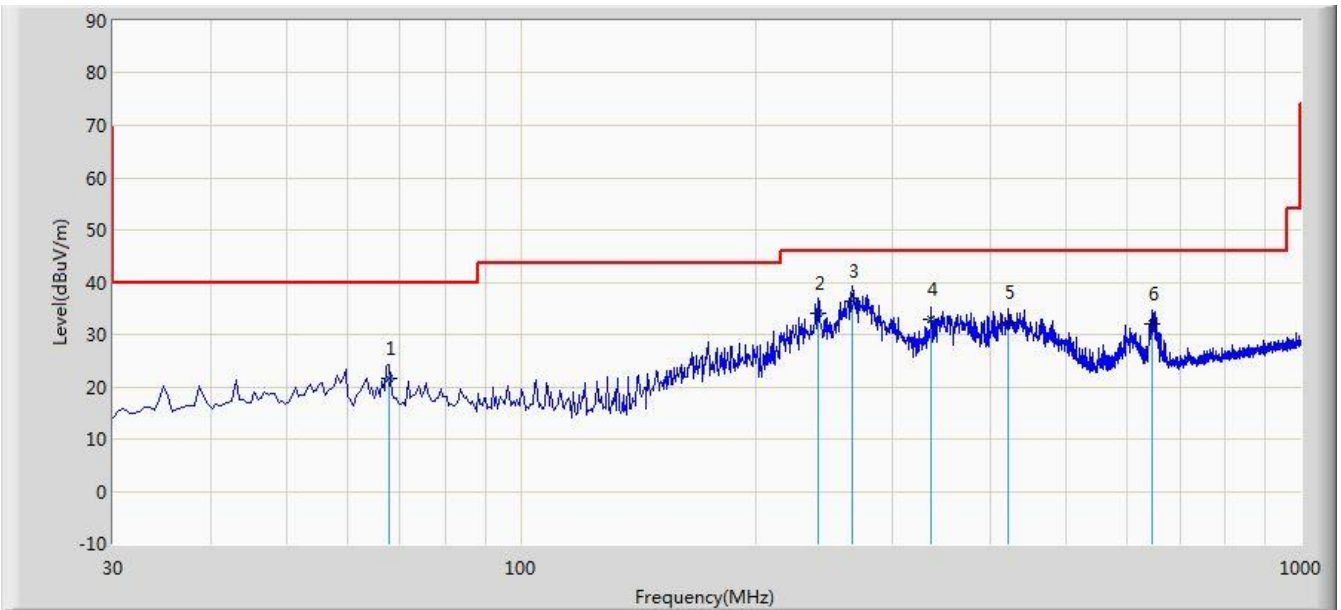

No	Flag	Mark	Frequency (MHz)	Measure Level (dBuV/m)	Reading Level (dBuV)	Over Limit (dB)	Limit (dBuV/m)	Factor (dB)	Type
1			67.830	21.659	10.012	-18.341	40.000	11.648	QP
2			240.975	34.042	20.445	-11.958	46.000	13.597	QP
3		*	266.195	36.296	22.128	-9.704	46.000	14.169	QP
4			336.035	32.908	17.152	-13.092	46.000	15.755	QP
5			421.880	32.252	14.988	-13.748	46.000	17.265	QP
6			644.950	32.079	11.213	-13.921	46.000	20.866	QP

Note 1: Measure Level (dB $\mu$ V/m) = Reading Level (dB $\mu$ V) + Factor (dB)

Factor (dB) = Cable Loss (dB) + Antenna Factor (dB/m)

Note 2: The test trace is same as the ambient noise and the amplitude of the emissions are attenuated more than 20dB below the permissible (the test frequency range: 9kHz ~ 30MHz, 18GHz ~ 25GHz), therefore no data appear in the report.

## 7.8. Radiated Restricted Band Edge Measurement

### 7.8.1. Test Limit

#### **For 15.205 requirement:**

Radiated emissions which fall in the restricted bands, as defined in Section 15.205(a) of FCC part 15, must also comply with the radiated emission limits specified in Section 15.209(a).

Frequency (MHz)	Frequency (MHz)	Frequency (MHz)	Frequency (GHz)
0.090 - 0.110	16.42 - 16.423	399.9 - 410	4.5 - 5.15
<sup>1</sup> 0.495 - 0.505	16.69475 - 16.69525	608 - 614	5.35 - 5.46
2.1735 - 2.1905	16.80425 - 16.80475	960 - 1240	7.25 - 7.75
4.125 - 4.128	25.5 - 25.67	1300 - 1427	8.25 - 8.5
4.17725 - 4.17775	37.5 - 38.25	1435 - 1626.5	9.0 - 9.2
4.20725 - 4.20775	73 - 74.6	1645.5 - 1646.5	9.3 - 9.5
6.215 - 6.218	74.8 - 75.2	1660 - 1710	10.6 - 12.7
6.26775 - 6.26825	108 - 121.94	1718.8 - 1722.2	13.25 - 13.4
6.31175 - 6.31225	123 - 138	2200 - 2300	14.47 - 14.5
8.291 - 8.294	149.9 - 150.05	2310 - 2390	15.35 - 16.2
8.362 - 8.366	156.52475 - 156.525	2483.5 - 2500	17.7 - 21.4
8.37625 - 8.38675	156.7 - 156.9	2690 - 2900	22.01 - 23.12
8.41425 - 8.41475	162.0125 - 167.17	3260 - 3267	23.6 - 24.0
12.29 - 12.293	167.72 - 173.2	3332 - 3339	31.2 - 31.8
12.51975 - 12.52025	240 - 285	3345.8 - 3358	36.43 - 36.5
12.57675 - 12.57725	322 - 335.4	3600 - 4400	( <sup>2</sup> )
13.36 - 13.41	--	--	--



**For 15.407(b) requirement:**

For transmitters operating in the 5.15-5.25 GHz band: All emissions outside of the 5.15-5.35 GHz band shall not exceed an e.i.r.p. of -27 dBm/MHz.

For transmitters operating in the 5.725-5.85 GHz band:

All emissions shall be limited to a level of -27 dBm/MHz at 75 MHz or more above or below the band edge increasing linearly to 10 dBm/MHz at 25 MHz above or below the band edge, and from 25 MHz above or below the band edge increasing linearly to a level of 15.6 dBm/MHz at 5 MHz above or below the band edge, and from 5 MHz above or below the band edge increasing linearly to a level of 27 dBm/MHz at the band edge.

All out of band emissions appearing in a restricted band as specified in Section 15.205 of the Title 47 CFR must not exceed the limits shown in Table per Section 15.209.

FCC Part 15 Subpart C Paragraph 15.209		
Frequency [MHz]	Field Strength [V/m]	Measured Distance [Meters]
0.009 – 0.490	2400/F (kHz)	300
0.490 – 1.705	24000/F (kHz)	30
1.705 - 30	30	30
30 - 88	100	3
88 - 216	150	3
216 - 960	200	3
Above 960	500	3

**For RSS-Gen Section 8.10 Requirement:**

Radiated emissions which fall in the restricted bands, as defined in Section 8.10 of RSS-Gen, must also comply with the radiated emission limits specified in Section 8.9.

Frequency (MHz)	Frequency (MHz)	Frequency (GHz)
0.009 - 0.110	240 - 285	9.0 - 9.2
2.1735 - 2.1905	322 - 335.4	9.3 - 9.5
3.020 - 3.026	399.9 - 410	10.6 - 12.7
4.125 - 4.128	608 - 614	13.25 - 13.4
4.17725 - 4.17775	960 - 1427	14.47 - 14.5
4.20725 - 4.20775	1435 - 1626.5	15.35 - 16.2
5.677 - 5.683	1645.5 - 1646.5	17.7 - 21.4
6.215 - 6.218	1660 - 1710	22.01 - 23.12
6.26775 - 6.26825	1718.8 - 1722.2	23.6 - 24.0
6.31175 - 6.31225	2200 - 2300	31.2 - 31.8
8.291 - 8.294	2310 - 2390	36.43 - 36.5
8.362 - 8.366	2655 - 2900	Above 38.6
8.37625 - 8.38675	3260 - 3267	--
8.41425 - 8.41475	3332 - 3339	
12.29 - 12.293	3345.8 - 3358	
12.51975 - 12.52025	3500 - 4400	
12.57675 - 12.57725	4500 - 5150	
13.36 - 13.41	5350 - 5460	
16.42 - 16.423	7250 - 7750	
16.69475 - 16.69525	8025 - 8500	
16.80425 - 16.80475	--	
25.5 - 25.67		
37.5 - 38.25		
73 - 74.6		
74.8 - 75.2		
108 - 138		
156.52475 - 156.525225		
156.7 - 156.9		

Note: \*Certain frequency bands listed in Table 6 and in bands above 38.6 GHz are designated for licence-exempt applications. These frequency bands and the requirements that apply to the devices

are set out in the 200- and 300-series of RSSs, such as RSS-210 and RSS-310, which contain the requirements that apply to licence-exempt radio apparatus.

For transmitters operating in the 5.15-5.25 GHz band: All emissions outside of the 5.15-5.35 GHz band shall not exceed an e.i.r.p. of  $-27$  dBm/MHz.

For transmitters operating in the band 5725-5850 MHz shall have e.i.r.p. of unwanted emissions comply with the following:

- a) 27 dBm/MHz at frequencies from the band edges decreasing linearly to 15.6 dBm/MHz at 5MHz above or below the band edges;
- b) 15.6 dBm/MHz at 5 MHz above or below the band edges decreasing linearly to 10 dBm/MHz at 25 MHz above or below the band edges;
- c) 10 dBm/MHz at 25 MHz above or below the band edges decreasing linearly to  $-27$  dBm/MHz at 75 MHz above or below the band edges; and
- d)  $-27$  dBm/MHz at frequencies more than 75 MHz above or below the band edges.

All out of band emissions appearing in a restricted band as specified in Section 8.10 of the RSS-Gen must not exceed the limits shown in Table per Section 8.9.

RSS-Gen Section 8.9		
Frequency [MHz]	Field Strength [ $\mu$ V/m]	Measured Distance [Meters]
0.009 - 0.490	2400/F (kHz)	300
0.490 - 1.705	24000/F (kHz)	30
1.705 - 30	30	30
30 - 88	100	3
88 - 216	150	3
216 - 960	200	3
Above 960	500	3

### 7.8.2. Test Result

Site: AC1	Time: 2018/04/18 - 02:37
Limit: FCC_Part15.209_RE(3m)	Engineer: Kevin Ker
Probe: BBHA9120D_1GHz_18GHz	Polarity: Horizontal
EUT: Mantis Q Remote Controller	Power: By Battery
Note: Transmit by 802.11a at Channel 5180MHz Ant A	

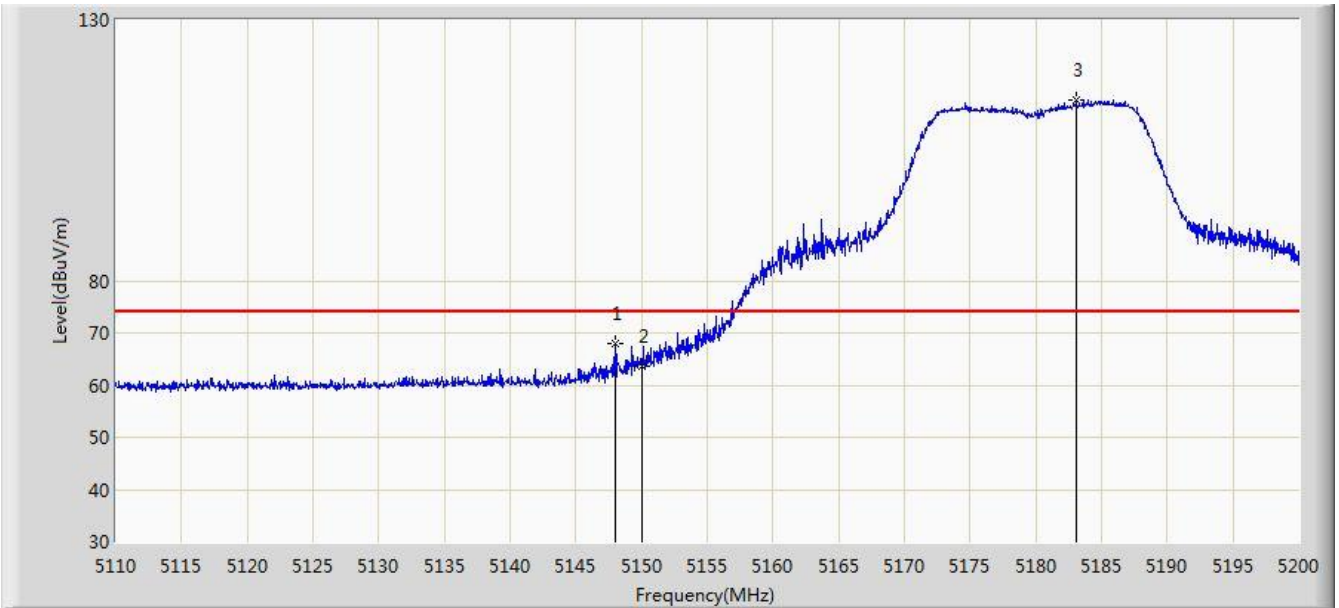

No	Flag	Mark	Frequency (MHz)	Measure Level (dBuV/m)	Reading Level (dBuV)	Over Limit (dB)	Limit (dBuV/m)	Factor (dB)	Type
1			5148.025	67.929	63.754	-6.071	74.000	4.176	PK
2			5150.000	63.760	59.591	-10.240	74.000	4.170	PK
3		*	5183.080	114.713	110.655	N/A	N/A	4.057	PK

Note: Measure Level (dB $\mu$ V/m) = Reading Level (dB $\mu$ V) + Factor (dB)

Factor (dB) = Cable Loss (dB) + Antenna Factor (dB/m) - Pre\_Amplifier Gain (dB)

Site: AC1	Time: 2018/04/18 - 02:52
Limit: FCC_Part15.209_RE(3m)	Engineer: Kevin Ker
Probe: BBHA9120D_1GHz_18GHz	Polarity: Horizontal
EUT: Mantis Q Remote Controller	Power: By Battery
Note: Transmit by 802.11a at Channel 5180MHz Ant A	

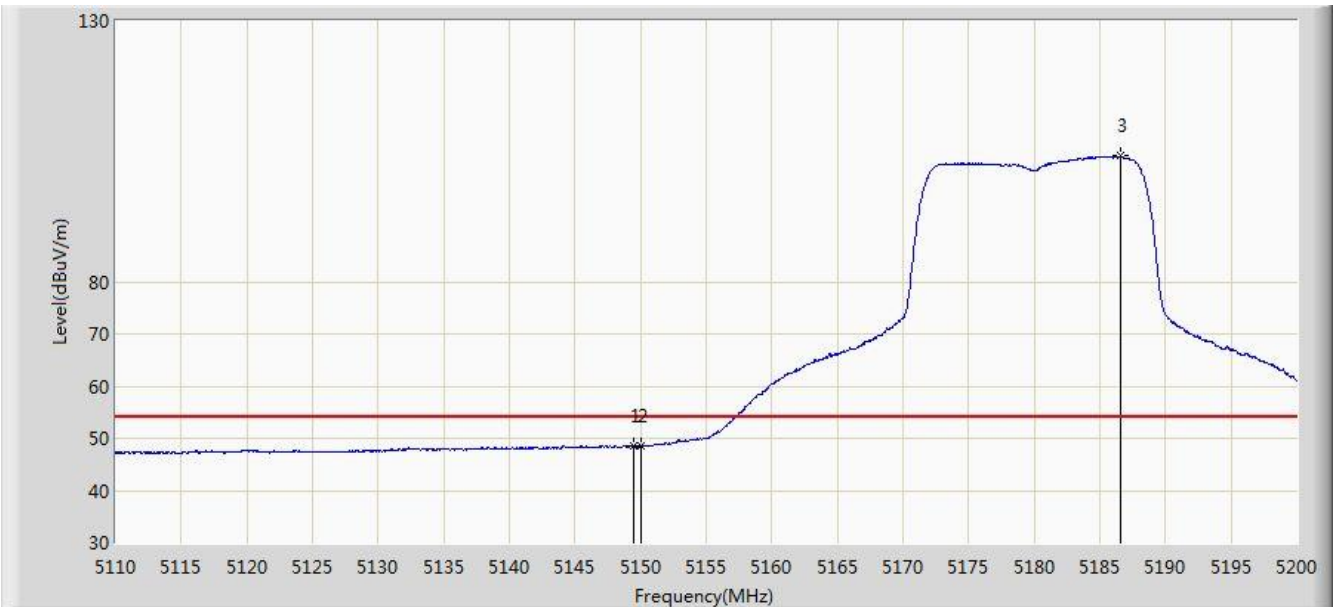

No	Flag	Mark	Frequency (MHz)	Measure Level (dBuV/m)	Reading Level (dBuV)	Over Limit (dB)	Limit (dBuV/m)	Factor (dB)	Type
1			5149.465	48.622	44.451	-5.378	54.000	4.170	AV
2			5150.000	48.503	44.334	-5.497	54.000	4.170	AV
3		*	5186.635	104.079	100.034	N/A	N/A	4.045	AV

Note: Measure Level (dB $\mu$ V/m) = Reading Level (dB $\mu$ V) + Factor (dB)

Factor (dB) = Cable Loss (dB) + Antenna Factor (dB/m) - Pre\_Amplifier Gain (dB)

Site: AC1	Time: 2018/04/18 - 02:48
Limit: FCC_Part15.209_RE(3m)	Engineer: Kevin Ker
Probe: BBHA9120D_1GHz_18GHz	Polarity: Vertical
EUT: Mantis Q Remote Controller	Power: By Battery
Note: Transmit by 802.11a at Channel 5180MHz Ant A	

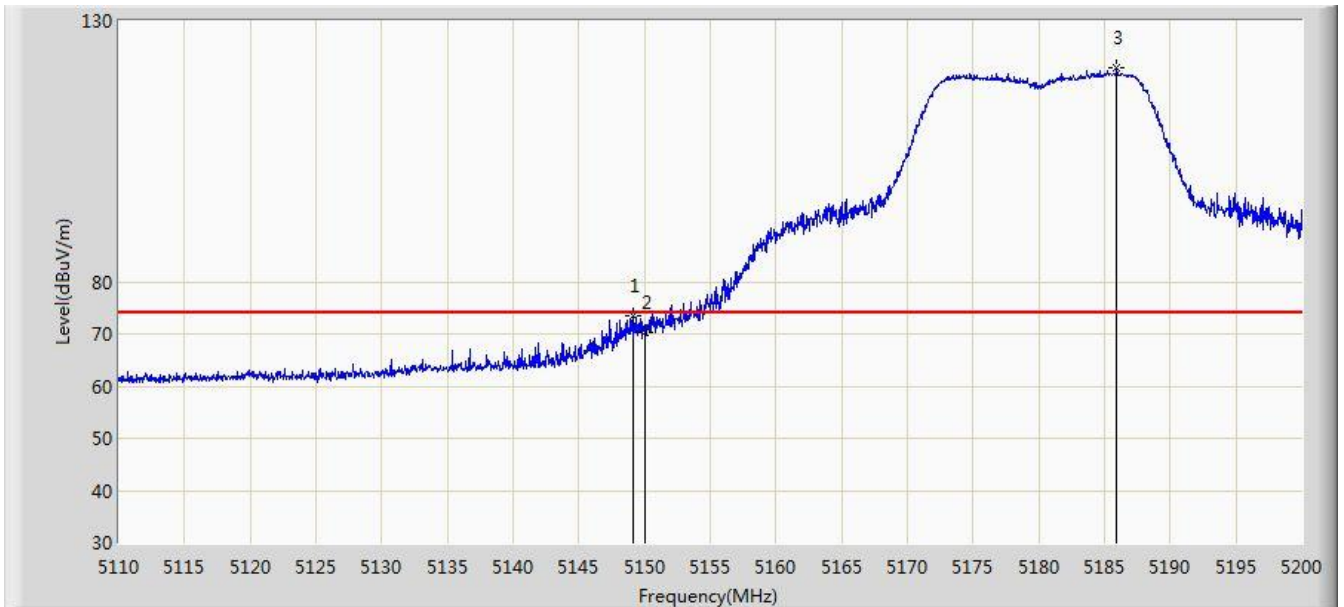

No	Flag	Mark	Frequency (MHz)	Measure Level (dBuV/m)	Reading Level (dBuV)	Over Limit (dB)	Limit (dBuV/m)	Factor (dB)	Type
1			5149.105	73.391	69.219	-0.609	74.000	4.173	PK
2			5150.000	70.346	66.177	-3.654	74.000	4.170	PK
3		*	5185.915	120.926	116.878	N/A	N/A	4.049	PK

Note: Measure Level (dB $\mu$ V/m) = Reading Level (dB $\mu$ V) + Factor (dB)

Factor (dB) = Cable Loss (dB) + Antenna Factor (dB/m) - Pre\_Amplifier Gain (dB)

Site: AC1	Time: 2018/04/18 - 03:05
Limit: FCC_Part15.209_RE(3m)	Engineer: Kevin Ker
Probe: BBHA9120D_1GHz_18GHz	Polarity: Vertical
EUT: Mantis Q Remote Controller	Power: By Battery
Note: Transmit by 802.11a at Channel 5180MHz Ant A	

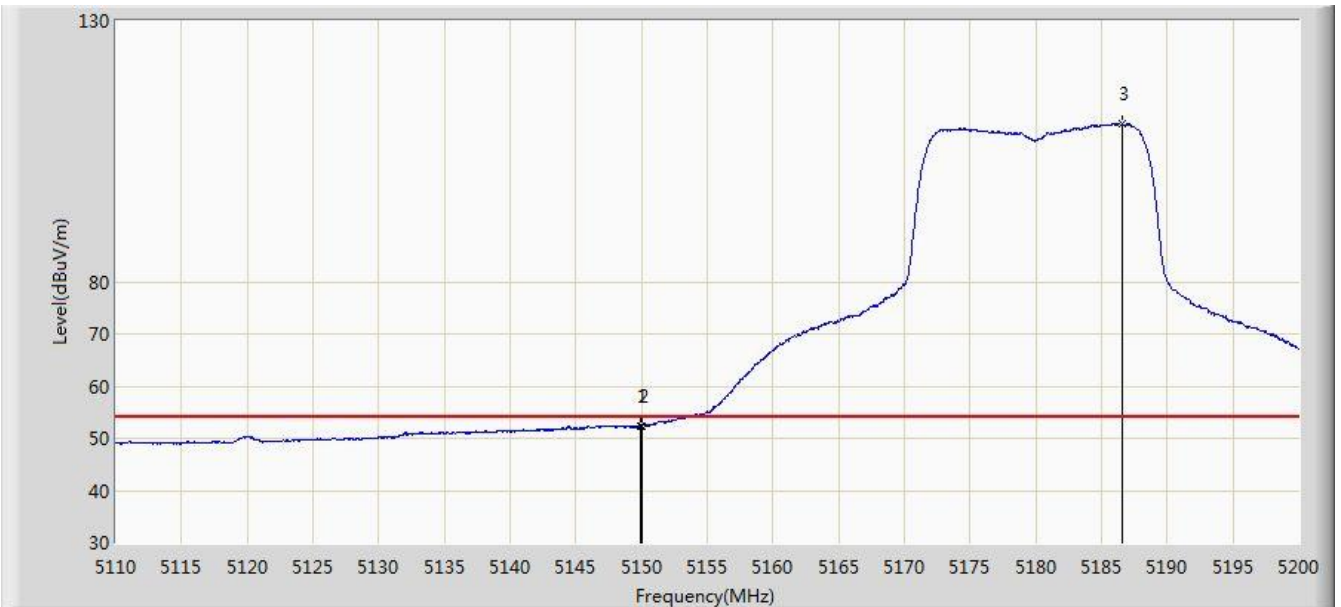

No	Flag	Mark	Frequency (MHz)	Measure Level (dBuV/m)	Reading Level (dBuV)	Over Limit (dB)	Limit (dBuV/m)	Factor (dB)	Type
1			5149.915	52.458	48.288	-1.542	54.000	4.170	AV
2			5150.000	52.295	48.126	-1.705	54.000	4.170	AV
3	X	*	5186.635	110.308	106.263	N/A	N/A	4.045	AV

Note: Measure Level (dB $\mu$ V/m) = Reading Level (dB $\mu$ V) + Factor (dB)

Factor (dB) = Cable Loss (dB) + Antenna Factor (dB/m) - Pre\_Amplifier Gain (dB)

Site: AC1	Time: 2018/04/18 - 03:08
Limit: FCC_Part15.209_RE(3m)	Engineer: Kevin Ker
Probe: BBHA9120D_1GHz_18GHz	Polarity: Horizontal
EUT: Mantis Q Remote Controller	Power: By Battery
Note: Transmit by 802.11a at Channel 5745MHz Ant A	

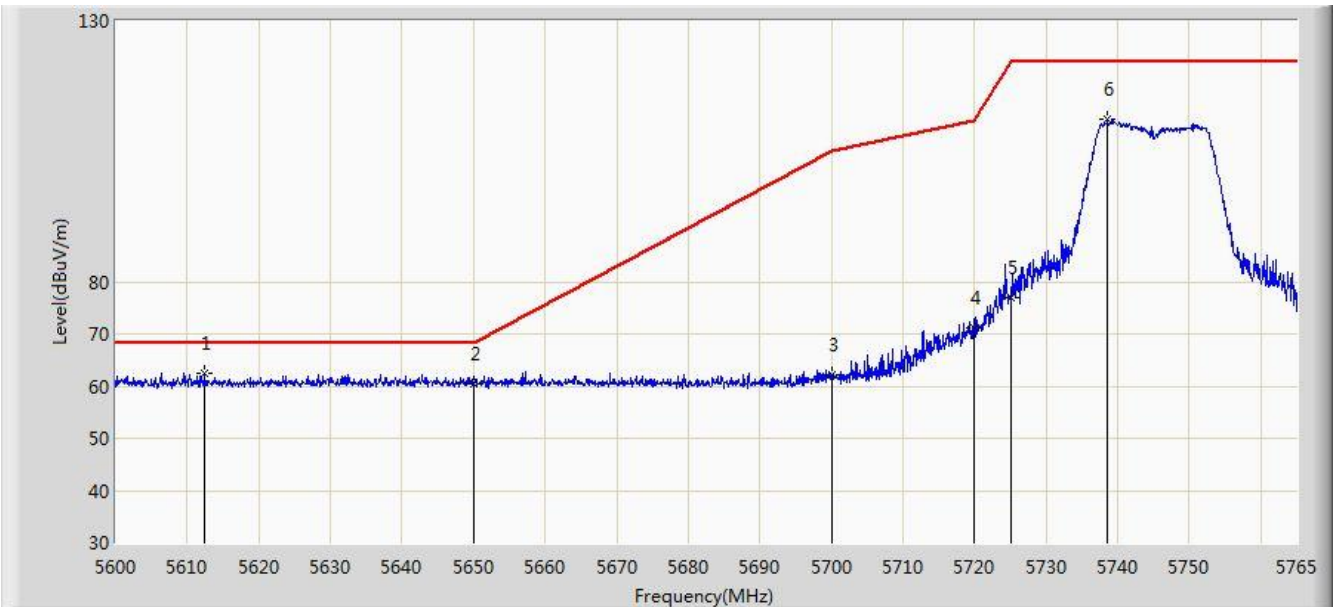

No	Flag	Mark	Frequency (MHz)	Measure Level (dBuV/m)	Reading Level (dBuV)	Over Limit (dB)	Limit (dBuV/m)	Factor (dB)	Type
1		*	5612.458	62.565	58.006	-5.635	68.200	4.558	PK
2			5650.000	60.431	55.760	-7.769	68.200	4.671	PK
3			5700.000	62.119	57.241	-43.081	105.200	4.878	PK
4			5720.000	71.095	66.098	-39.705	110.800	4.997	PK
5			5725.000	76.998	71.969	-45.202	122.200	5.029	PK
6			5738.600	111.128	106.012	N/A	N/A	5.115	PK

Note: Measure Level (dB $\mu$ V/m) = Reading Level (dB $\mu$ V) + Factor (dB)

Factor (dB) = Cable Loss (dB) + Antenna Factor (dB/m) - Pre\_Amplifier Gain (dB)



Site: AC1	Time: 2018/04/18 - 03:34
Limit: FCC_Part15.209_RE(3m)	Engineer: Kevin Ker
Probe: BBHA9120D_1GHz_18GHz	Polarity: Vertical
EUT: Mantis Q Remote Controller	Power: By Battery
Note: Transmit by 802.11a at Channel 5745MHz Ant A	

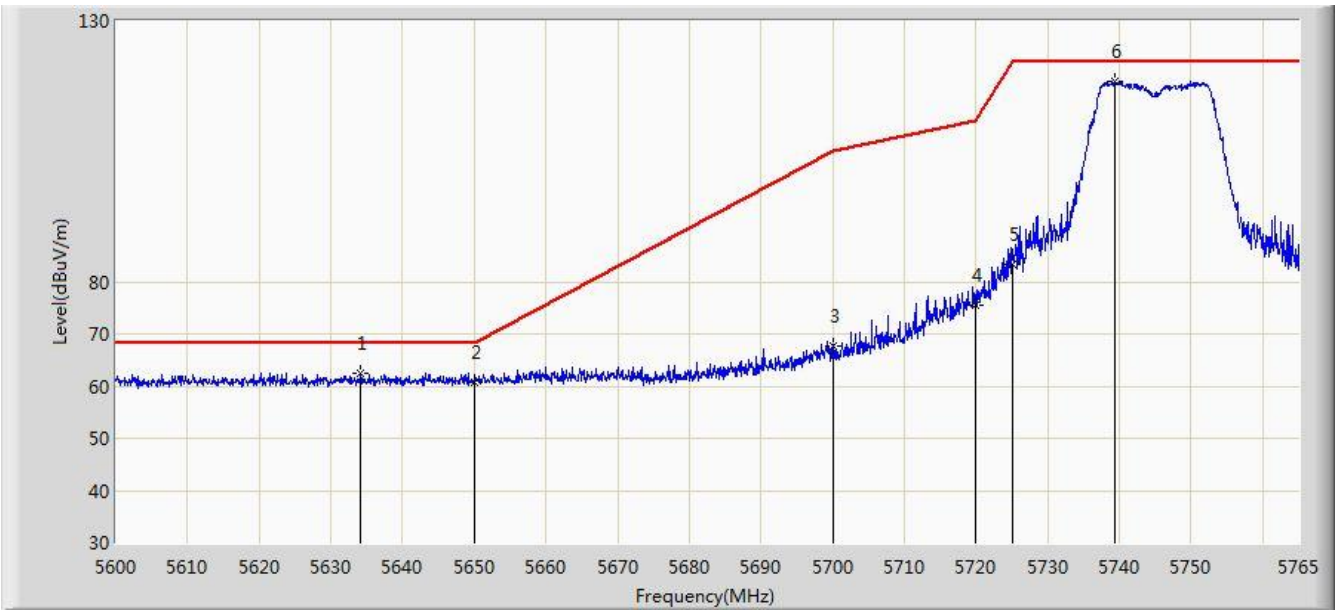

No	Flag	Mark	Frequency (MHz)	Measure Level (dBuV/m)	Reading Level (dBuV)	Over Limit (dB)	Limit (dBuV/m)	Factor (dB)	Type
1			5634.155	62.534	57.913	-5.666	68.200	4.621	PK
2			5650.000	60.672	56.001	-7.528	68.200	4.671	PK
3			5700.000	67.728	62.850	-37.472	105.200	4.878	PK
4			5720.000	75.386	70.389	-35.414	110.800	4.997	PK
5			5725.000	83.238	78.209	-38.962	122.200	5.029	PK
6		*	5739.342	118.438	113.318	N/A	N/A	5.120	PK

Note: Measure Level (dB $\mu$ V/m) = Reading Level (dB $\mu$ V) + Factor (dB)

Factor (dB) = Cable Loss (dB) + Antenna Factor (dB/m) - Pre\_Amplifier Gain (dB)

Site: AC1	Time: 2018/04/18 - 03:37
Limit: FCC_Part15.209_RE(3m)	Engineer: Kevin Ker
Probe: BBHA9120D_1GHz_18GHz	Polarity: Horizontal
EUT: Mantis Q Remote Controller	Power: By Battery
Note: Transmit by 802.11a at Channel 5825MHz Ant A	

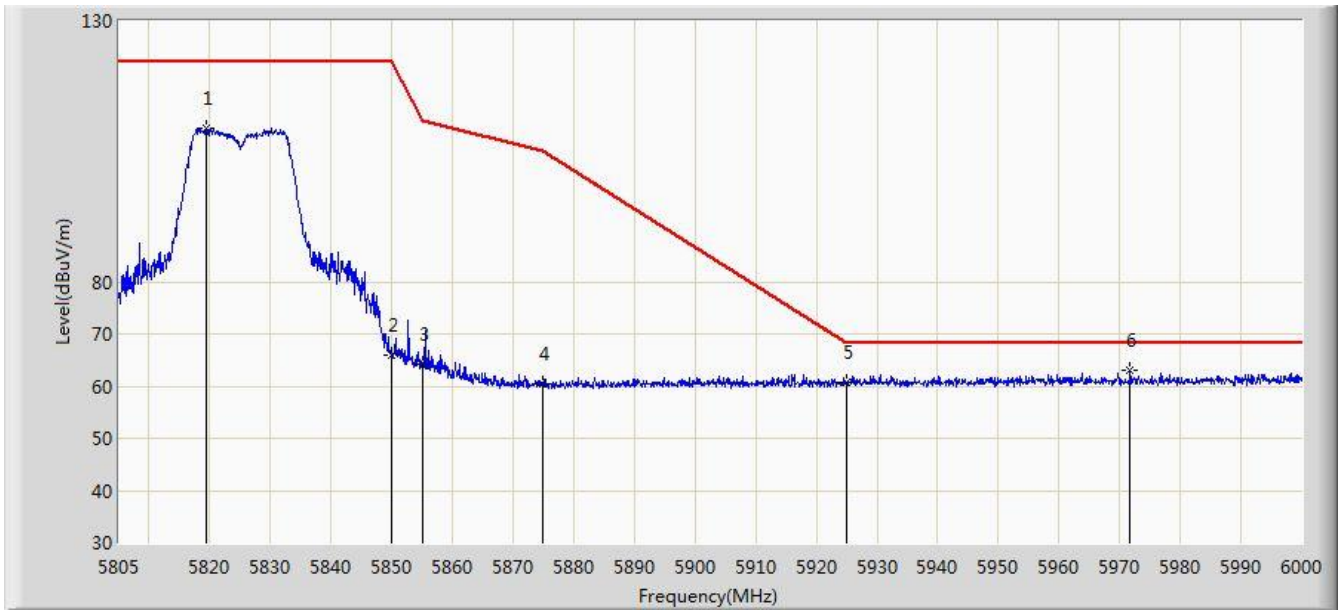

No	Flag	Mark	Frequency (MHz)	Measure Level (dBuV/m)	Reading Level (dBuV)	Over Limit (dB)	Limit (dBuV/m)	Factor (dB)	Type
1			5819.527	109.524	103.968	N/A	N/A	5.556	PK
2			5850.000	65.924	60.198	-56.276	122.200	5.726	PK
3			5855.000	64.128	58.382	-46.672	110.800	5.746	PK
4			5875.000	60.470	54.650	-44.730	105.200	5.820	PK
5			5925.000	60.741	54.775	-7.459	68.200	5.967	PK
6		*	5971.725	62.991	56.927	-5.209	68.200	6.063	PK

Note: Measure Level (dB $\mu$ V/m) = Reading Level (dB $\mu$ V) + Factor (dB)

Factor (dB) = Cable Loss (dB) + Antenna Factor (dB/m) - Pre\_Amplifier Gain (dB)

Site: AC1	Time: 2018/04/18 - 03:40
Limit: FCC_Part15.209_RE(3m)	Engineer: Kevin Ker
Probe: BBHA9120D_1GHz_18GHz	Polarity: Vertical
EUT: Mantis Q Remote Controller	Power: By Battery
Note: Transmit by 802.11a at Channel 5825MHz Ant A	

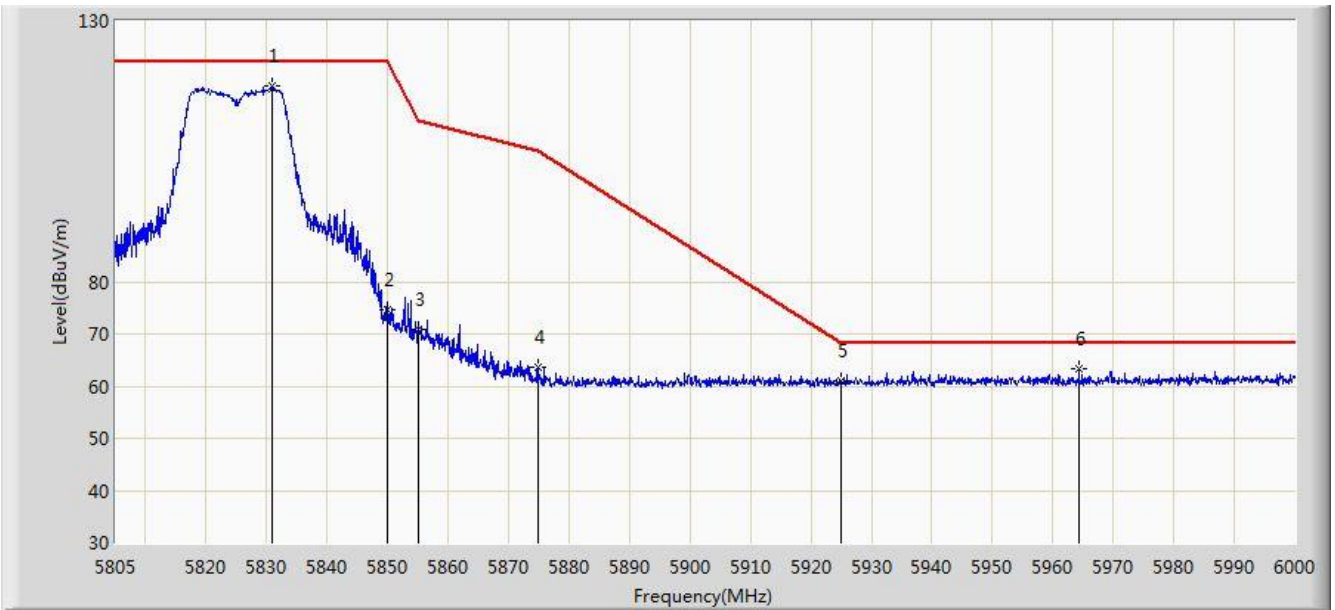

No	Flag	Mark	Frequency (MHz)	Measure Level (dBuV/m)	Reading Level (dBuV)	Over Limit (dB)	Limit (dBuV/m)	Factor (dB)	Type
1		*	5830.935	117.418	111.795	N/A	N/A	5.622	PK
2			5850.000	74.744	69.018	-47.456	122.200	5.726	PK
3			5855.000	70.845	65.099	-39.955	110.800	5.746	PK
4			5875.000	63.532	57.712	-41.668	105.200	5.820	PK
5			5925.000	60.959	54.993	-7.241	68.200	5.967	PK
6			5964.315	63.376	57.325	-4.824	68.200	6.051	PK

Note: Measure Level (dB $\mu$ V/m) = Reading Level (dB $\mu$ V) + Factor (dB)

Factor (dB) = Cable Loss (dB) + Antenna Factor (dB/m) - Pre\_Amplifier Gain (dB)

Site: AC1	Time: 2018/04/18 - 03:43
Limit: FCC_Part15.209_RE(3m)	Engineer: Kevin Ker
Probe: BBHA9120D_1GHz_18GHz	Polarity: Horizontal
EUT: Mantis Q Remote Controller	Power: By Battery
Note: Transmit by 802.11n-HT20 at Channel 5180MHz Ant A	

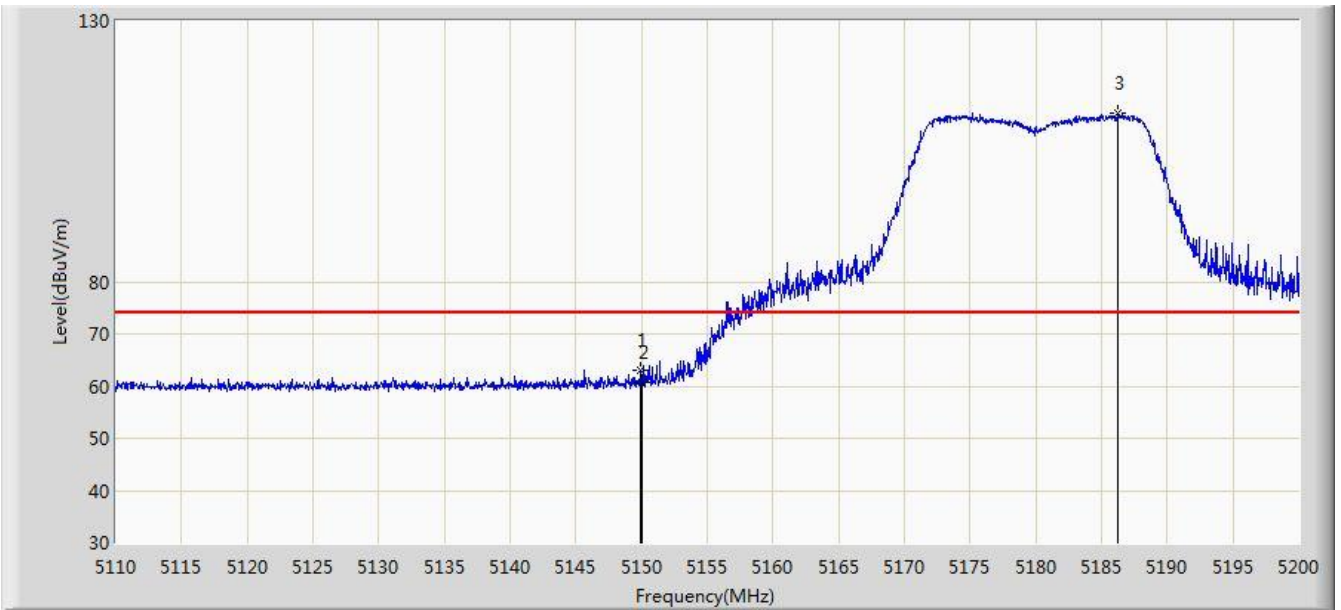

No	Flag	Mark	Frequency (MHz)	Measure Level (dBuV/m)	Reading Level (dBuV)	Over Limit (dB)	Limit (dBuV/m)	Factor (dB)	Type
1			5149.960	63.066	58.897	-10.934	74.000	4.170	PK
2			5150.000	60.859	56.690	-13.141	74.000	4.170	PK
3		*	5186.230	112.296	108.249	N/A	N/A	4.047	PK

Note: Measure Level (dB $\mu$ V/m) = Reading Level (dB $\mu$ V) + Factor (dB)

Factor (dB) = Cable Loss (dB) + Antenna Factor (dB/m) - Pre\_Amplifier Gain (dB)

Site: AC1	Time: 2018/04/18 - 03:46
Limit: FCC_Part15.209_RE(3m)	Engineer: Kevin Ker
Probe: BBHA9120D_1GHz_18GHz	Polarity: Horizontal
EUT: Mantis Q Remote Controller	Power: By Battery
Note: Transmit by 802.11n-HT20 at Channel 5180MHz Ant A	

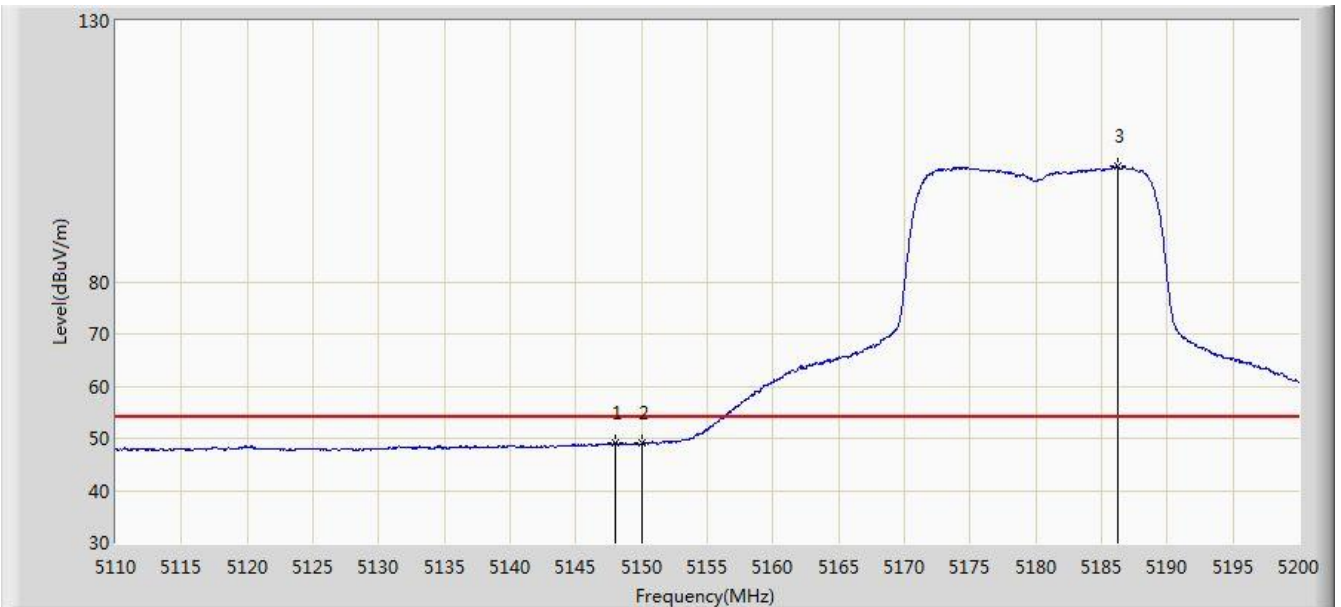

No	Flag	Mark	Frequency (MHz)	Measure Level (dBuV/m)	Reading Level (dBuV)	Over Limit (dB)	Limit (dBuV/m)	Factor (dB)	Type
1			5147.980	49.200	45.024	-4.800	54.000	4.176	AV
2			5150.000	48.989	44.820	-5.011	54.000	4.170	AV
3		*	5186.230	102.114	98.067	N/A	N/A	4.047	AV

Note: Measure Level (dB $\mu$ V/m) = Reading Level (dB $\mu$ V) + Factor (dB)

Factor (dB) = Cable Loss (dB) + Antenna Factor (dB/m) - Pre\_Amplifier Gain (dB)

Site: AC1	Time: 2018/04/18 - 03:49
Limit: FCC_Part15.209_RE(3m)	Engineer: Kevin Ker
Probe: BBHA9120D_1GHz_18GHz	Polarity: Vertical
EUT: Mantis Q Remote Controller	Power: By Battery
Note: Transmit by 802.11n-HT20 at Channel 5180MHz Ant A	

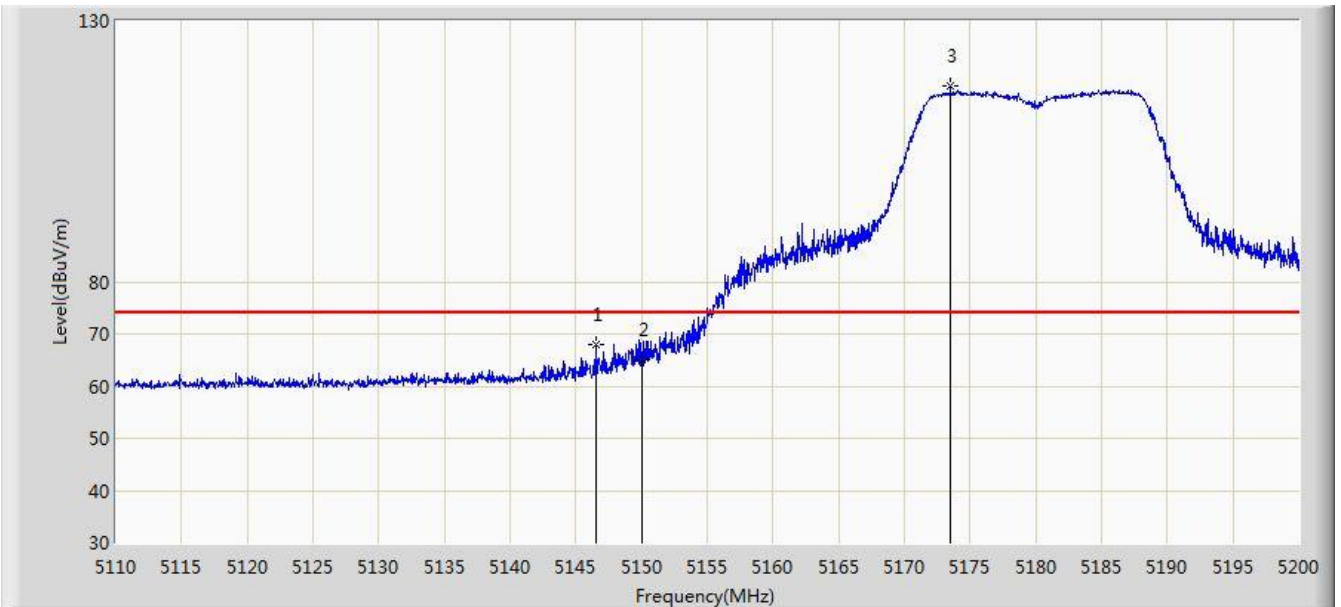

No	Flag	Mark	Frequency (MHz)	Measure Level (dBuV/m)	Reading Level (dBuV)	Over Limit (dB)	Limit (dBuV/m)	Factor (dB)	Type
1			5146.585	67.961	63.785	-6.039	74.000	4.176	PK
2			5150.000	65.067	60.898	-8.933	74.000	4.170	PK
3		*	5173.495	117.543	113.451	N/A	N/A	4.092	PK

Note: Measure Level (dB $\mu$ V/m) = Reading Level (dB $\mu$ V) + Factor (dB)

Factor (dB) = Cable Loss (dB) + Antenna Factor (dB/m) - Pre\_Amplifier Gain (dB)

Site: AC1	Time: 2018/04/18 - 03:51
Limit: FCC_Part15.209_RE(3m)	Engineer: Kevin Ker
Probe: BBHA9120D_1GHz_18GHz	Polarity: Vertical
EUT: Mantis Q Remote Controller	Power: By Battery
Note: Transmit by 802.11n-HT20 at Channel 5180MHz Ant A	

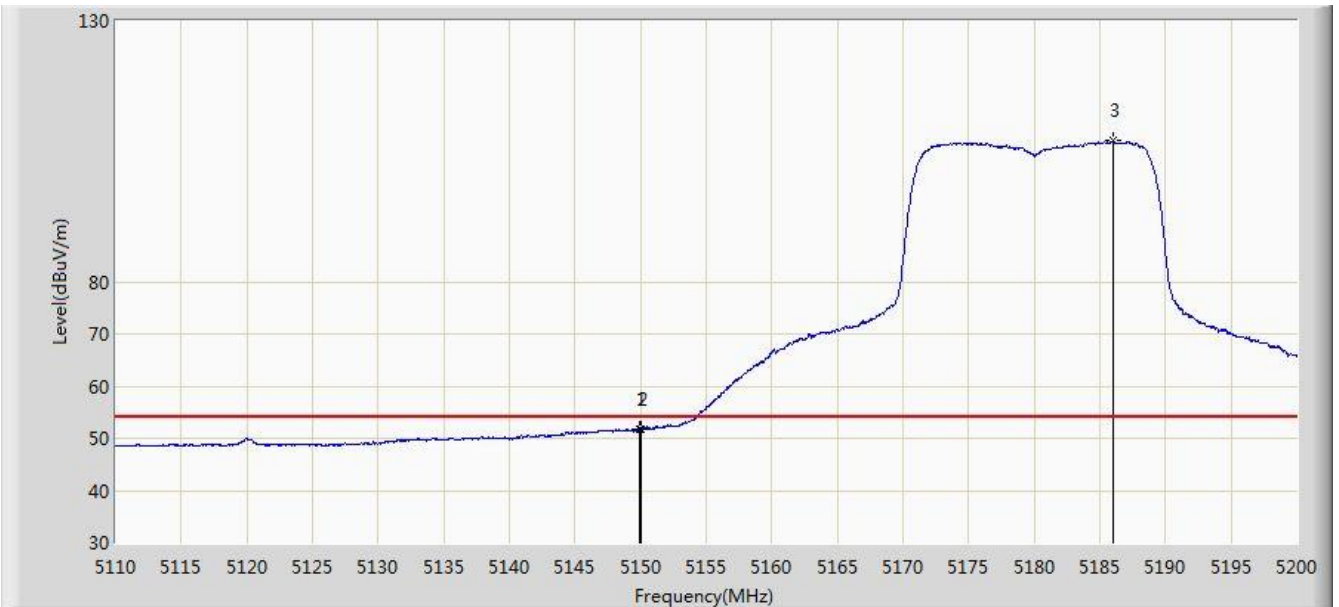

No	Flag	Mark	Frequency (MHz)	Measure Level (dBuV/m)	Reading Level (dBuV)	Over Limit (dB)	Limit (dBuV/m)	Factor (dB)	Type
1			5149.915	51.860	47.690	-2.140	54.000	4.170	AV
2			5150.000	51.664	47.495	-2.336	54.000	4.170	AV
3		*	5186.005	106.973	102.925	N/A	N/A	4.048	AV

Note: Measure Level (dB $\mu$ V/m) = Reading Level (dB $\mu$ V) + Factor (dB)

Factor (dB) = Cable Loss (dB) + Antenna Factor (dB/m) - Pre\_Amplifier Gain (dB)

Site: AC1	Time: 2018/04/18 - 03:53
Limit: FCC_Part15.209_RE(3m)	Engineer: Kevin Ker
Probe: BBHA9120D_1GHz_18GHz	Polarity: Horizontal
EUT: Mantis Q Remote Controller	Power: By Battery
Note: Transmit by 802.11n-HT20 at Channel 5745MHz Ant A	

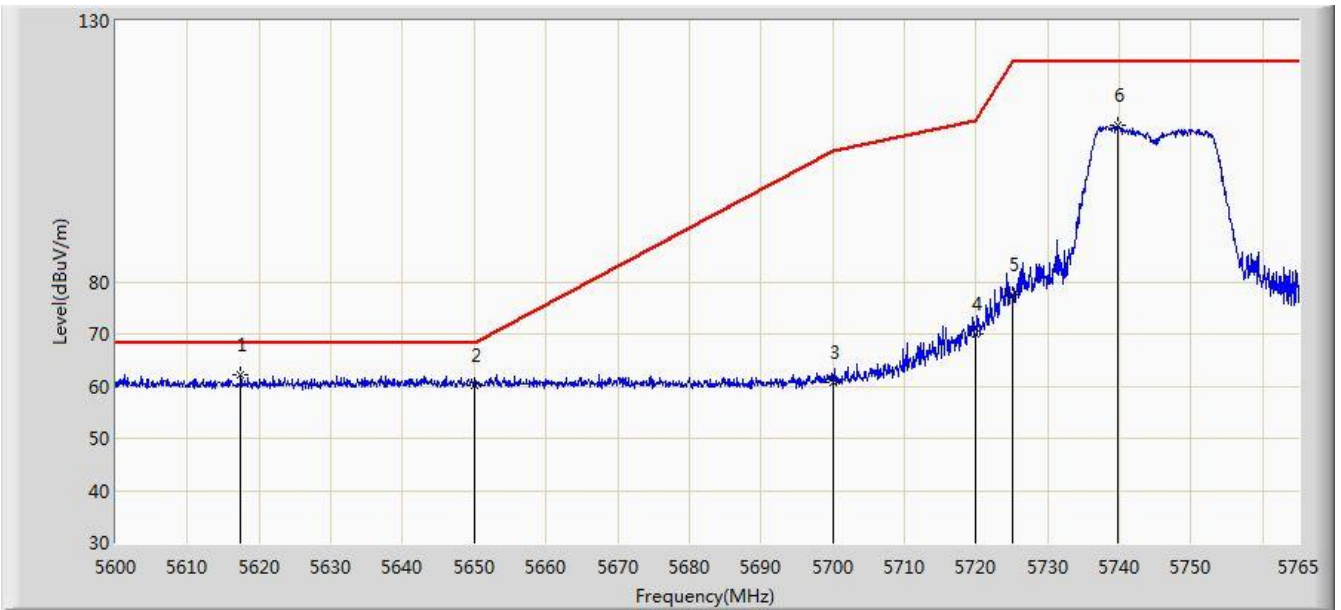

No	Flag	Mark	Frequency (MHz)	Measure Level (dBuV/m)	Reading Level (dBuV)	Over Limit (dB)	Limit (dBuV/m)	Factor (dB)	Type
1		*	5617.408	62.037	57.464	-6.163	68.200	4.572	PK
2			5650.000	60.178	55.507	-8.022	68.200	4.671	PK
3			5700.000	60.801	55.923	-44.399	105.200	4.878	PK
4			5720.000	69.901	64.904	-40.899	110.800	4.997	PK
5			5725.000	77.471	72.442	-44.729	122.200	5.029	PK
6			5739.837	109.924	104.800	N/A	N/A	5.123	PK

Note: Measure Level (dB $\mu$ V/m) = Reading Level (dB $\mu$ V) + Factor (dB)

Factor (dB) = Cable Loss (dB) + Antenna Factor (dB/m) - Pre\_Amplifier Gain (dB)



Site: AC1	Time: 2018/04/18 - 03:56
Limit: FCC_Part15.209_RE(3m)	Engineer: Kevin Ker
Probe: BBHA9120D_1GHz_18GHz	Polarity: Vertical
EUT: Mantis Q Remote Controller	Power: By Battery
Note: Transmit by 802.11n-HT20 at Channel 5745MHz Ant A	

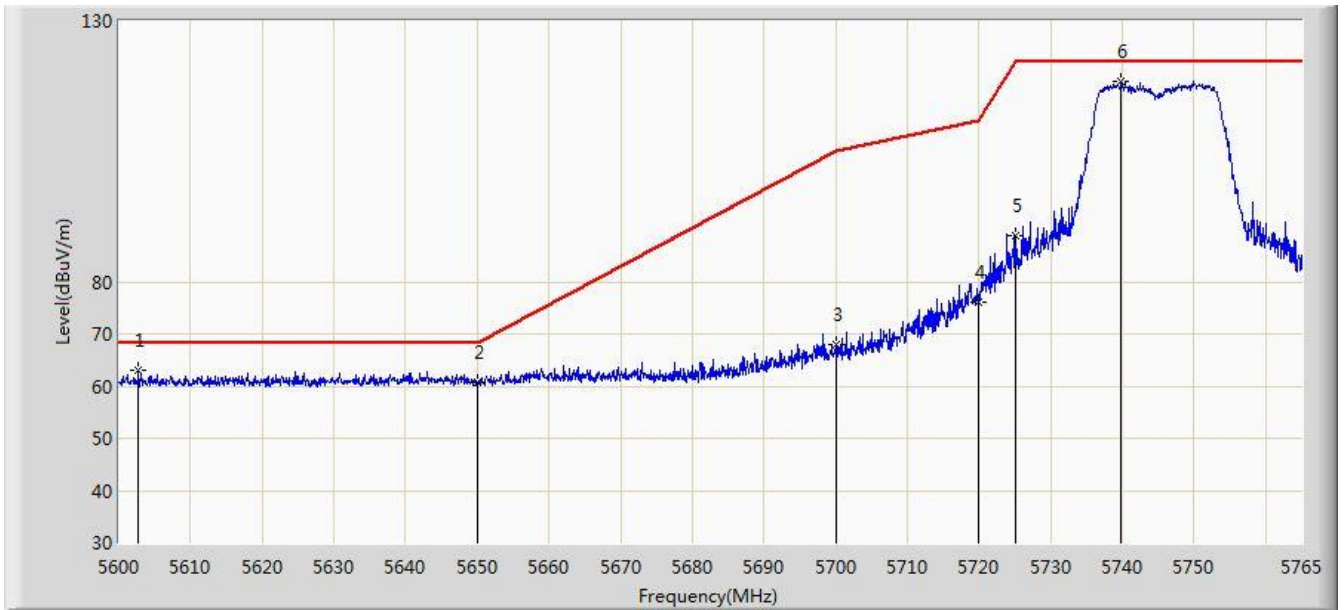

No	Flag	Mark	Frequency (MHz)	Measure Level (dBuV/m)	Reading Level (dBuV)	Over Limit (dB)	Limit (dBuV/m)	Factor (dB)	Type
1			5602.723	62.901	58.367	-5.299	68.200	4.534	PK
2			5650.000	60.763	56.092	-7.437	68.200	4.671	PK
3			5700.000	67.959	63.081	-37.241	105.200	4.878	PK
4			5720.000	76.206	71.209	-34.594	110.800	4.997	PK
5			5725.000	88.795	83.766	-33.405	122.200	5.029	PK
6		*	5739.837	118.271	113.147	N/A	N/A	5.123	PK

Note: Measure Level (dB $\mu$ V/m) = Reading Level (dB $\mu$ V) + Factor (dB)

Factor (dB) = Cable Loss (dB) + Antenna Factor (dB/m) - Pre\_Amplifier Gain (dB)

Site: AC1	Time: 2018/04/18 - 03:58
Limit: FCC_Part15.209_RE(3m)	Engineer: Kevin Ker
Probe: BBHA9120D_1GHz_18GHz	Polarity: Horizontal
EUT: Mantis Q Remote Controller	Power: By Battery
Note: Transmit by 802.11n-HT20 at Channel 5825MHz Ant A	

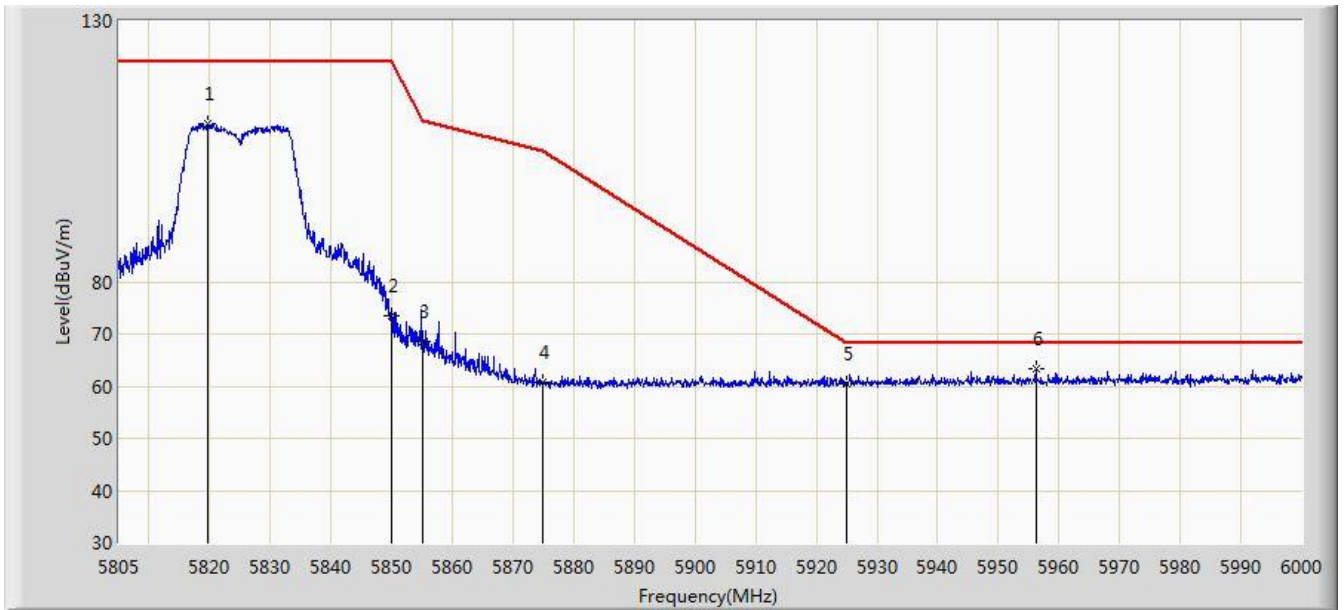

No	Flag	Mark	Frequency (MHz)	Measure Level (dBuV/m)	Reading Level (dBuV)	Over Limit (dB)	Limit (dBuV/m)	Factor (dB)	Type
1			5819.625	110.396	104.839	N/A	N/A	5.556	PK
2			5850.000	73.590	67.864	-48.610	122.200	5.726	PK
3			5855.000	68.435	62.689	-42.365	110.800	5.746	PK
4			5875.000	60.601	54.781	-44.599	105.200	5.820	PK
5			5925.000	60.566	54.600	-7.634	68.200	5.967	PK
6		*	5956.223	63.353	57.316	-4.847	68.200	6.037	PK

Note: Measure Level (dB $\mu$ V/m) = Reading Level (dB $\mu$ V) + Factor (dB)

Factor (dB) = Cable Loss (dB) + Antenna Factor (dB/m) - Pre\_Amplifier Gain (dB)

Site: AC1	Time: 2018/04/18 - 04:09
Limit: FCC_Part15.209_RE(3m)	Engineer: Kevin Ker
Probe: BBHA9120D_1GHz_18GHz	Polarity: Vertical
EUT: Mantis Q Remote Controller	Power: By Battery
Note: Transmit by 802.11n-HT20 at Channel 5825MHz Ant A	

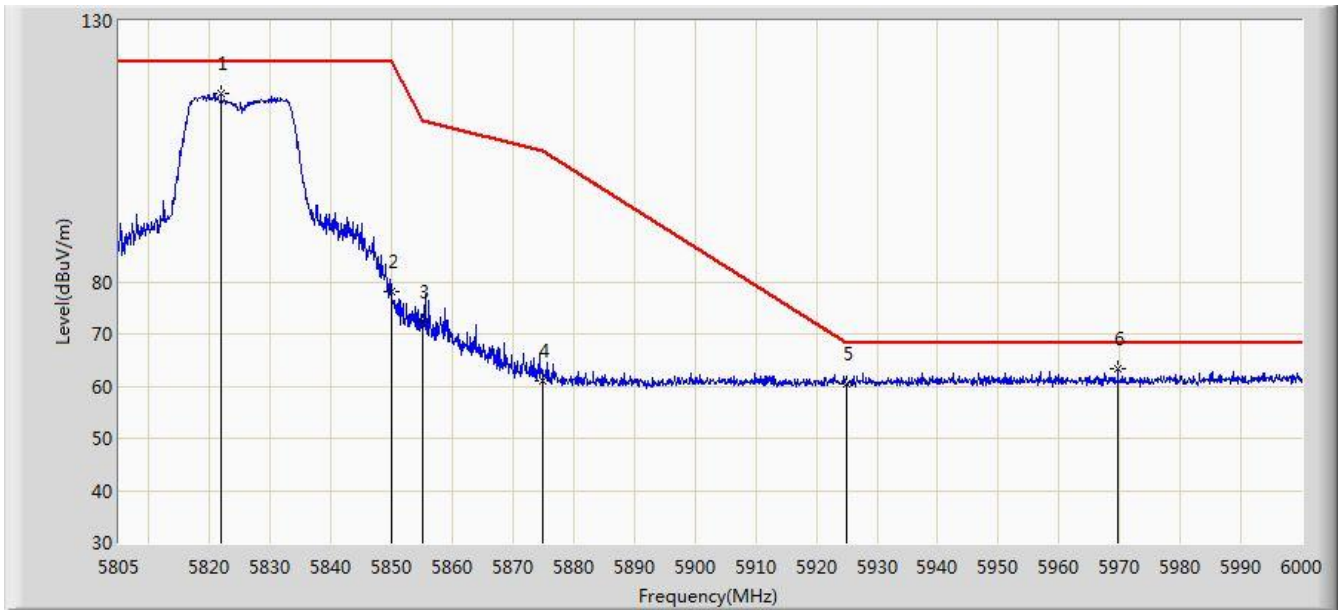

No	Flag	Mark	Frequency (MHz)	Measure Level (dBuV/m)	Reading Level (dBuV)	Over Limit (dB)	Limit (dBuV/m)	Factor (dB)	Type
1			5821.868	116.069	110.499	N/A	N/A	5.570	PK
2			5850.000	77.989	72.263	-44.211	122.200	5.726	PK
3			5855.000	72.443	66.697	-38.357	110.800	5.746	PK
4			5875.000	61.069	55.249	-44.131	105.200	5.820	PK
5			5925.000	60.412	54.446	-7.788	68.200	5.967	PK
6		*	5969.678	63.247	57.187	-4.953	68.200	6.061	PK
6		*	5969.678	63.247	57.187	-4.953	68.200	6.061	PK

Note: Measure Level (dB $\mu$ V/m) = Reading Level (dB $\mu$ V) + Factor (dB)

Factor (dB) = Cable Loss (dB) + Antenna Factor (dB/m) - Pre\_Amplifier Gain (dB)

## 7.9. AC Conducted Emissions Measurement

### 7.9.1. Test Limit

FCC 15.207 Limits		
Frequency (MHz)	QP (dBuV)	AV (dBuV)
0.15 ~ 0.50	66 ~ 56	56 ~ 46
0.50 ~ 5.0	56	46
5.0 ~ 30	60	50

Note 1: The lower limit shall apply at the transition frequencies.

Note 2: The limit decreases linearly with the logarithm of the frequency in the range 0.15MHz to 0.5MHz.

### 7.9.2. Test Setup

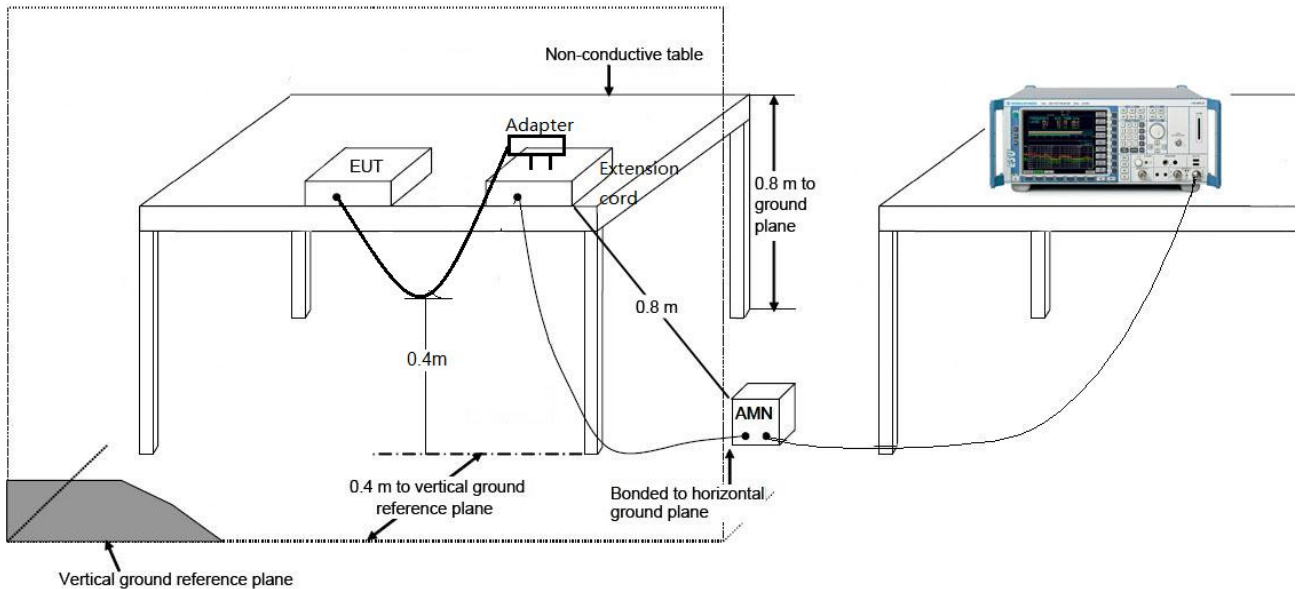

### 7.9.3. Test Result

Site: SR1	Time: 2018/04/25 - 02:10
Limit: FCC_Part15.207_CE_AC Power	Engineer: Kevin Ker
Probe: ENV216_101683_Filter On	Polarity: Line
EUT: Mantis Q Remote Controller	Power: AC 120V/60Hz
Test Mode 1	

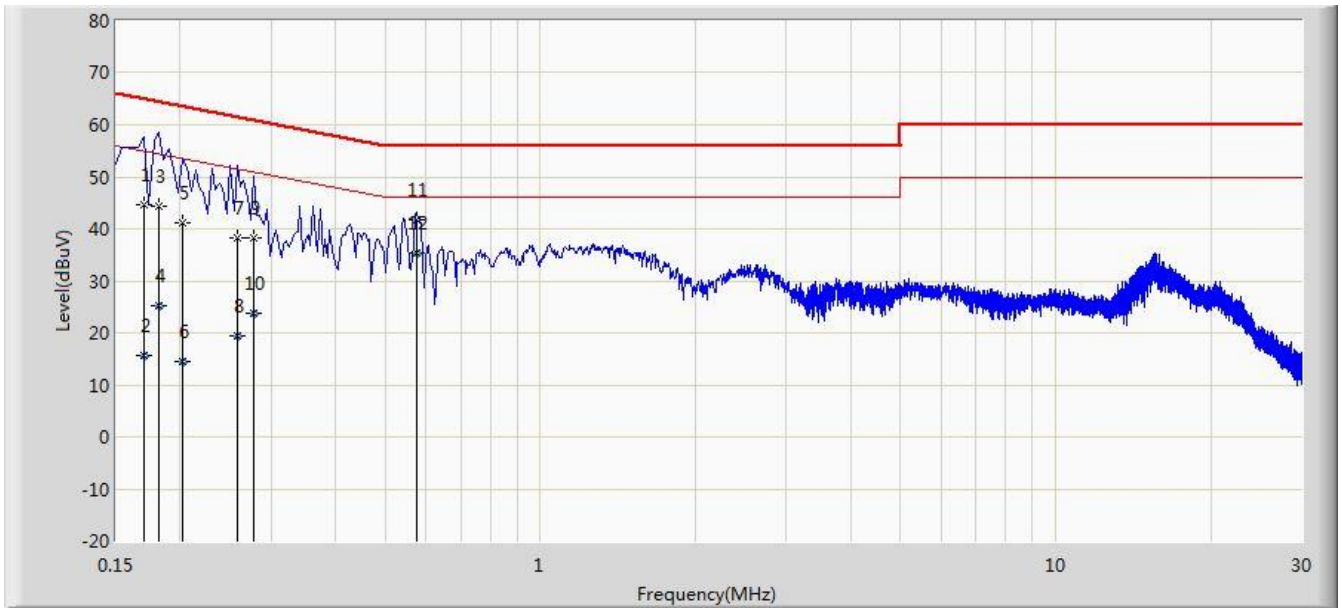

No	Flag	Mark	Frequency (MHz)	Measure Level (dBuV)	Reading Level (dBuV)	Over Limit (dB)	Limit (dBuV)	Factor (dB)	Type
1			0.170	44.772	34.694	-20.189	64.960	10.078	QP
2			0.170	15.596	5.519	-39.364	54.960	10.078	AV
3			0.182	44.467	34.419	-19.927	64.394	10.048	QP
4			0.182	25.307	15.259	-29.087	54.394	10.048	AV
5			0.202	41.028	31.035	-22.500	63.528	9.993	QP
6			0.202	14.445	4.452	-39.083	53.528	9.993	AV
7			0.258	38.383	28.413	-23.112	61.496	9.970	QP
8			0.258	19.337	9.366	-32.159	51.496	9.970	AV
9			0.278	38.196	28.209	-22.680	60.875	9.986	QP
10			0.278	23.642	13.655	-27.233	50.875	9.986	AV
11			0.574	41.835	31.707	-14.165	56.000	10.128	QP
12		*	0.574	35.236	25.108	-10.764	46.000	10.128	AV

Note: Measure Level (dB $\mu$ V) = Reading Level (dB $\mu$ V) + Factor (dB)

Factor (dB) = Cable Loss (dB) + LISN Factor (dB)

Site: SR1	Time: 2018/04/25 - 02:14
Limit: FCC_Part15.207_CE_AC Power	Engineer: Kevin Ker
Probe: ENV216_101683_Filter On	Polarity: Neutral
EUT: Mantis Q Remote Controller	Power: AC 120V/60Hz
Test Mode 1	

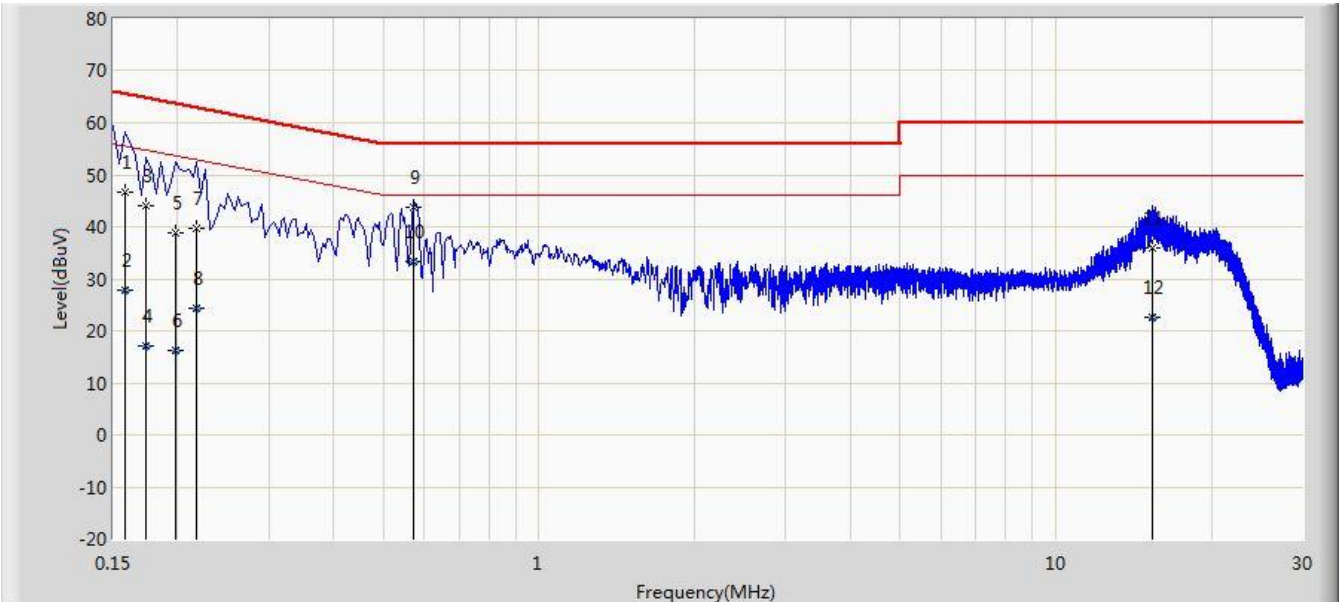

No	Flag	Mark	Frequency (MHz)	Measure Level (dBuV)	Reading Level (dBuV)	Over Limit (dB)	Limit (dBuV)	Factor (dB)	Type
1			0.158	46.693	36.403	-18.876	65.568	10.290	QP
2			0.158	27.817	17.527	-27.752	55.568	10.290	AV
3			0.174	44.093	34.037	-20.674	64.767	10.057	QP
4			0.174	17.122	7.066	-37.645	54.767	10.057	AV
5			0.198	38.759	28.745	-24.935	63.694	10.015	QP
6			0.198	16.364	6.349	-37.330	53.694	10.015	AV
7			0.218	39.768	29.787	-23.127	62.895	9.981	QP
8			0.218	24.415	14.434	-28.479	52.895	9.981	AV
9		*	0.570	43.831	33.683	-12.169	56.000	10.148	QP
10			0.570	33.361	23.213	-12.639	46.000	10.148	AV
11			15.322	35.996	25.881	-24.004	60.000	10.116	QP
12			15.322	22.669	12.554	-27.331	50.000	10.116	AV

Note: Measure Level (dBμV) = Reading Level (dBμV) + Factor (dB)

Factor (dB) = Cable Loss (dB) + LISN Factor (dB)

## 8. CONCLUSION

The data collected relate only the item(s) tested and show that the **Mantis Q Remote Controller** is in compliance with Part 15E of the FCC Rules and ISED Rules.

---

The End